



POWER PROTECTION

UPStation[®] S3

Three Phase

12 kVA to 24 kVA; 50 and 60 Hz

**User
Manual**

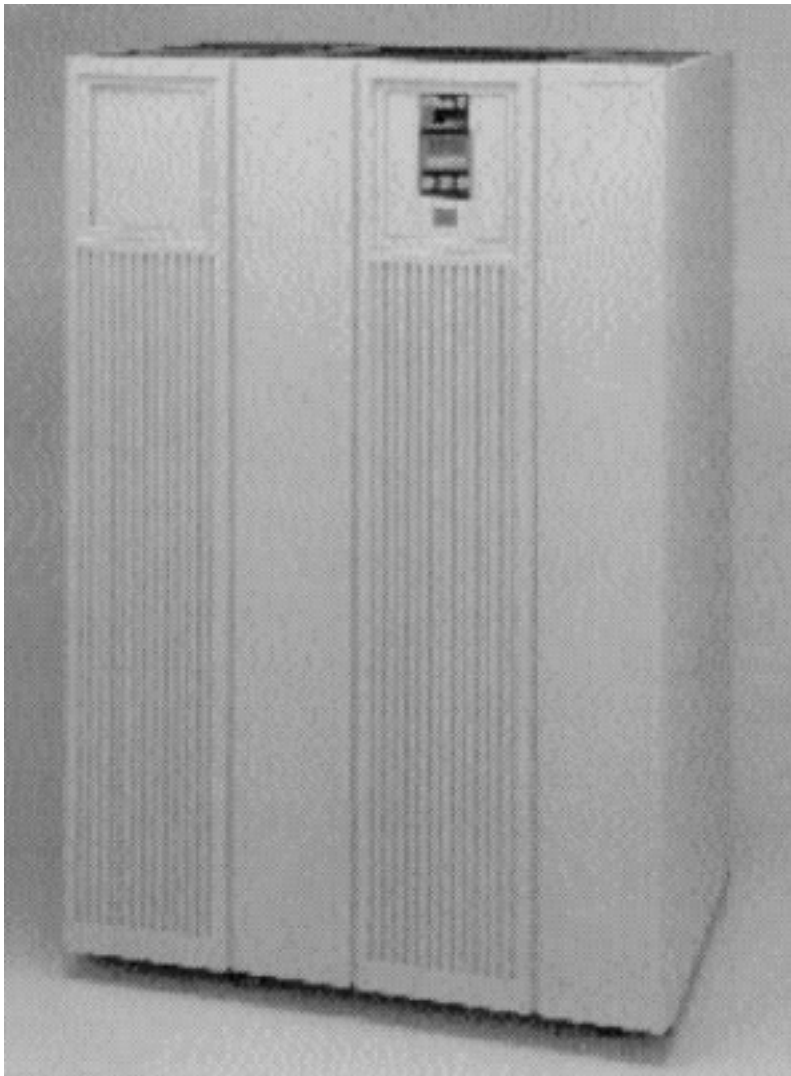

TABLE OF CONTENTS

IMPORTANT SAFETY INSTRUCTIONS	1
1.0 INTRODUCTION	
1.1 Description	3
1.2 Site Planning Data	3
1.3 UPS Cabinet	3
1.3.1 Casters and Feet	3
1.3.2 Cooling	3
1.3.3 Access	3
1.4 System Components	4
1.4.1 Standard UPS Unit	4
1.4.2 Options	4
1.5 Modes of Operation	5
1.5.1 Normal (Utility Power)	5
1.5.2 On Battery	5
1.5.3 Battery Recharge	5
1.5.4 On Bypass	5
1.5.5 Remote Emergency Off	5
2.0 INSTALLATION	
2.1 Safety Precautions	6
2.2 UPS Installation	7
2.2.1 Installation Considerations	8
2.2.2 Unloading and External Inspection	8
2.2.3 Internal Inspection of the UPS System	8
2.2.4 Equipment Location	9
2.3 Batteries	9
2.4 Electrical Wiring	11
2.4.1 UPS Wire Size Guidelines	11
2.4.2 Power & Control Wiring	12
2.4.3 Battery Wiring	13
2.4.4 Wiring Connections	14
2.4.5 Wiring Inspection	14
3.0 OPERATION	
3.1 Control / Display Panel	39
3.1.1 Control Buttons	39
3.1.2 LCD Display	40
3.2 System Start-Up	44
3.2.1 Initial Start-Up	44
3.2.2 Manual Restart after Manual Off	44
3.2.3 Manual Restart after Low Battery Shutdown	44
3.2.4 Manual Restart after EPO or REPO	44
3.2.5 Auto-Restart	44
3.3 Normal Operation	44

3.4	Battery Operation	45
3.4.1	On Battery	45
3.4.2	Battery Recharge	45
3.5	Bypass Operation	46
3.5.1	Static Transfer Switch	46
3.5.2	Maintenance Bypass.	48
3.6	System Shutdown.	48
3.6.1	Manual Off	48
3.6.2	Automatic Off	48
3.6.3	Remote Emergency Off.	48
3.7	User Response to UPS Alarms	50
4.0	FEATURES & OPTIONS	
4.1	Introduction	56
4.2	RS-232 Communication Feature	56
4.3	Factory Installed Options	57
4.3.1	Dual Input.	57
4.3.2	3% Input Current THD	57
4.3.3	Isolated Neutral	57
4.3.4	Transformer Cabinet	57
4.3.5	Output Distribution Panel.	58
4.3.6	Battery Cabinets.	58
4.4	Field Installable Options	58
4.4.1	External Battery Cabinets.	58
4.4.2	Communication Options.	59
4.4.3	Programmable Relays	59
4.4.4	Input Contact Isolator	60
4.4.5	Delayed Battery Recharge	60
4.4.6	Optional DC Ground Fault Alarm.	60
4.4.7	Optional Remote Status Panel.	60
4.4.8	Floor Anchors	61
4.4.9	Optional Power Supply.	61
5.0	MAINTENANCE	
5.1	Routine Maintenance Requirements.	64
5.1.1	Air Filter Maintenance.	64
5.1.2	Cleaning	64
5.1.3	Troubleshooting	64
5.2	Battery Maintenance	64
6.0	SPECIFICATIONS	
6.1	System.	66
6.2	Physical Characteristics.	66
6.3	AC Input	66
6.4	AC Output.	66
6.5	Battery	66

FIGURES

Figure 1	One Line Drawing - Single Input Configuration (200/240V In/Out)	17
Figure 2	One Line Drawing - Dual Input Configuration (200/240V In/Out)	18
Figure 3	One Line Drawing - Single Input Configuration With Neutral Isolation (200/240V In/Out)	19
Figure 4	One Line Drawing - Dual Input Configuration With Neutral Isolation (200/240V In/Out)	20
Figure 5	One Line Drawing - Single Input Configuration (400/480/600V In / 208V Out)	21
Figure 6	One Line Drawing - Dual Input Configuration (400/480/600V In / 208V Out)	22
Figure 7	One Line Drawing - Single Input Configuration With Neutral Isolation (400/480/600V In / 208V Out)	23
Figure 8	One Line Drawing - Dual Input Configuration With Neutral Isolation (400/480/600V In / 208V Out)	24
Figure 9	One Line Drawing - Single Input Configuration (400/480/600V In/Out)	25
Figure 10	One Line Drawing - Dual Input Configuration (400/480/600V In/Out)	26
Figure 11	One Line Drawing - Single Input Configuration With Neutral Isolation (400/480/600V In/Out)	27
Figure 12	One Line Drawing - Dual Input Configuration With Neutral Isolation (400/480/600V In/Out)	28
Figure 13	Cabinet Dimensions	29
Figure 14	Cabinet Dimensions - With Transformer Cabinet	30
Figure 15	Connecting Terminal Details	31
Figure 16	Connecting Terminal Details - With Transformer Cabinet	32
Figure 17	Battery Option Details - 12 Inch Cabinet	33
Figure 18	Battery Option Details - 24 Inch Cabinet	34
Figure 19	Field Lug Wiring Terminations	35
Figure 20	Unloading Instructions	36
Figure 21	Unloading Instructions - 24 Inch Battery Cabinet	37
Figure 22	Battery Times	38
Figure 23	LCD Display	40
Figure 24	LCD Menu Tree	46
Figure 25	Configuration Menu Tree	47
Figure 26	Control Switch Locations	49
Figure 27	RS-232 Connections	62
Figure 28	Output Distribution Panel Board	63

TABLES

Table 1	Site Planning Data	2
Table 2	Table 310-16	15
Table 3	UPS Module Power Wiring Termination - Factory Supplied	16
Table 4	Torque Specifications (Unless Otherwise Labeled)	16
Table 5	Alarm Messages	52

IMPORTANT SAFETY INSTRUCTIONS

Save These Instructions.

This manual contains important safety instructions that should be followed during installation and maintenance of your UPStation® S3 UPS and batteries.

Conserver Ces Instructions

Cette Notice Contient Des Instructions Importantes Concernant La Sécurité.



WARNING

LETHAL VOLTAGES MAY BE PRESENT WITHIN THIS UNIT EVEN WHEN IT IS APPARENTLY NOT OPERATING. OBSERVE ALL CAUTIONS AND WARNINGS IN THIS MANUAL. FAILURE TO DO SO COULD RESULT IN SERIOUS INJURY OR DEATH.

REFER UNIT TO QUALIFIED SERVICE PERSONNEL IF MAINTENANCE IS REQUIRED. DO NOT WORK ON THIS EQUIPMENT UNLESS YOU ARE FULLY QUALIFIED TO DO SO. NEVER WORK ALONE.

SERVICING OF BATTERIES SHOULD BE PERFORMED OR SUPERVISED BY PERSONNEL KNOWLEDGEABLE OF BATTERIES AND THE REQUIRED PRECAUTIONS. KEEP UNAUTHORIZED PERSONNEL AWAY FROM BATTERIES. OBSERVE ALL BATTERY SAFETY PRECAUTIONS WHEN WORKING ON OR AROUND THE BATTERY.



CAUTION

This equipment complies with the requirements in part 15 of FCC rules for a Class A computing device. Operation of this equipment in a residential area may cause interference to radio and TV reception, requiring the operator to take whatever steps necessary to correct the interference.



ATTENTION INSTALLERS

Install the leveling feet while the unit is on the fork lift or otherwise lifted off the shipping pallet.

Use appropriate wire sizes and approved wiring techniques; details are covered in this manual

Make sure Phase Rotation is A, B, C.

This unit is shipped with one battery inter-cell cable disconnected for safety. For proper unit operation this inter-cell cable must be reconnected. Your Liebert Global Services personnel will perform this operation as part of their start up service.



WARNING

INTERNAL BATTERY STRAPPING MUST BE VERIFIED BY MANUFACTURER PRIOR TO MOVING THIS UNIT.

THIS UNIT CONTAINS NON-SPILLABLE BATTERIES. KEEP UNIT UPRIGHT. DO NOT STACK. DO NOT TIP.

FAILURE TO HEED THIS WARNING COULD RESULT IN SMOKE, FIRE, OR ELECTRIC HAZARD.

CALL 1-800-LIEBERT PRIOR TO MOVING UNIT.

Table 1 Site Planning Data

Model	Power Rating		Voltage	Single AC Input (Amp)			Dual AC Input (Amp)					Battery			AC Output (Amp)		Mechanical Data				
	kVA	kW		Nom	Max	REOP	Converter			Bypass		Nominal Voltage	Full Load kW	Max. Discharge Current	Current		Dimensions	Weight lbs (kg)	Heat Dissipation BTU/hr.	Cooling Air CFM	
			Nom				Max	REOP	Nom	REOP	Nom				REOP	WxDxH inches (cm)					
S312	12	8.4	208	33	40	50	28	35	50	33	50	240	9.9	51	33	50	29x27.25x62 (74x69x157)	700 (318)	4000 *4700	1000	
			240	29	35	50	24	30	40	29	40										
			400	17	21	30	15	19	30	17	30										
			480	14	18	30	13	16	20	14	20										
600	12	14	20	10	13	15	12	15	12	15	14	20	12	15	*(104x69x157)	*(567)					
S316	16	11.2	208	44	54	70	37	46	60	44	60	240	13.2	67	44	60	29x27.25x62 (74x69x157)	700 (318)	5300 *6300	1000	
			240	38	46	60	32	39	50	38	50										
			400	23	28	40	20	25	30	23	30										
			480	19	23	30	16	21	30	19	30										
600	15	19	30	13	16	20	15	20	15	20	19	30	19	30	*(104x69x157)	*(567)					
S320	20	14	208	56	67	100	46	58	70	56	80	240	16.5	84	56	80	29x27.25x62 (74x69x157)	700 (318)	6500 *7800	1000	
			240	48	58	70	39	49	60	48	70										
			400	29	35	50	25	31	40	29	40										
			480	24	29	40	21	26	40	24	30										
600	19	23	30	16	21	30	19	30	19	30	29	40	24	30	*(104x69x157)	*(567)					
S324	24	16.8	208	67	80	100	55	69	100	67	100	240	19.8	101	67	100	29x27.25x62 (74x69x157)	700 (318)	7200 *8500	1000	
			240	58	70	100	47	59	80	58	80										
			400	35	42	60	29	37	50	35	50										
			480	29	35	50	24	31	40	29	40										
600	23	28	40	20	24	30	23	30	29	40	29	40	29	40	*(104x69x157)	*(567)					
Applicable Notes:	—		1 2 3,9			1 2 3,9			1 3,9			5	—	6,9	1	7,8,9	12,13,14,15	15	—	—	
			10			10			10					10,11		10					
			11			11			11					13,14		11					
			13			13			13							13					
			14			14			14							14					

For explanation of **Applicable Notes**, see referenced numbers in **Notes** below.

REOP = Recommended External Overcurrent Protection

*Dimensions, Weights, and Heat Dissipation for 400, 480, and 600 VAC models

Notes

- Nominal (NOM) current is based on full rated output load.
- Maximum (MAX) current includes the short duration for battery recharge conditions.
- UPS input cables must be run in separate conduit from output cables.
- Reserved.
- Nominal battery voltage is shown at 2.0 volts/cell per NEC 480-2.
- Power cables from UPS DC link to batteries should be sized for a total maximum 2.0 volt line drop (measured at UPS) at maximum discharge current.
- Recommended AC output overcurrent protection represents 125% of nominal full load current (continuous) per NEC 220-3(a).
- UPS output load cables must be run in separate conduit from input cables.
- Minimum sized grounding conductors to be per NEC 250-95. Parity sized ground conductors are recommended. Neutral conductors to be sized for full capacity per NEC 310-16 Note 10.
- Wiring requirements:
 AC Output: 3-phase, 4-wire plus ground
 DC Input: 2-wire (positive and negative) plus ground
 Single Source AC Input: 3-phase, 4-wire plus ground
 Dual Source AC Input:
 Converter Input: 3-phase, 3-wire plus ground
 Bypass Input: 3-phase, 4-wire plus ground
- All wiring is to be in accordance with national and local electrical codes.
- Minimum access clearance is 3 feet front and 1 foot above the UPS.
- Top or bottom cable entry through removable access plates. Cut plate to suit conduit size, then replace.

Additional Notes

- If site configuration includes a back-up emergency generator, it is recommended that the engine generator set be properly sized and equipped for a UPS application. Generator options would typically include an isochronous governor (generator frequency regulation) and a UPS compatible regulator (generator voltage regulation). Consult generator manufacturer for required generator options and sizing.
- If site configuration includes an automatic transfer switch, refer to the Liebert Power Line titled "Criteria for Application of Automatic Transfer Switches (ATS) with Uninterruptible Power Supply (UPS) Systems" 91K-PLT-48-02. It is also recommended that the transfer switch be equipped with auxiliary contacts. Consult transfer switch manufacturer for required transfer switch options and sizing.

1.0 INTRODUCTION

1.1 Description

The UPStation® S3 uninterruptible power supply (UPS) system protects your valuable equipment, data, and processes from the disturbances present in utility power.

- Battery provides power to your loads during utility power outages.
- High-performance, on-line, microprocessor-controlled design ensures clean, regulated power to the load regardless of utility power fluctuations.
- Highly intelligent UPS puts you in control. Install the UPStation S3 and forget about it until the UPS alerts you to unusual circumstances. Or, configure the UPS to serve as a source of information and a power control base for your specific application. Programmable parameters, computer interfaces, and several network control features (remote status/control, event logging, and others) provide maximum application flexibility.
- Other features include:
 - a. On-line, sinewave UPS using microprocessor-controlled advanced switching technology
 - b. Three phase Pulse Width Modulated (PWM) inverter, with optional isolated neutral
 - c. Front Service Access without moving equipment
 - d. Flexible battery configurations
 - e. Two level, temperature-compensated battery recharge for longer battery life
 - f. Programmable voltage and frequency
 - g. Optional Output Distribution Panelboard
 - h. Minimal footprint
 - i. UL 1778 listed and CSA certified for user safety.

1.2 Site Planning Data

Refer to **Table 1 - Site Planning Data** for unit ratings, voltages, and dimensions.

The UPStation S3 is intended for installation in a temperature controlled, indoor area free of conductive contaminants.

1.3 UPS Cabinet

1.3.1 Casters and Feet

The unit is mounted on swiveling casters with leveling feet.

1.3.2 Cooling

The unit is forced-air cooled by internally-mounted fans. The filtered air intake is from the bottom of the unit and air exhaust is at the top.

1.3.3 Access

Front access only is required for operation and maintenance of the UPS. Equipment may be placed on both sides of the unit and the unit may be placed against a wall (2 in. clearance only).

1.4 System Components

1.4.1 Standard UPS Unit

- Bolt-on battery cabinet, factory connected
- Converter
- Inverter
- Static Transfer Switch
- Maintenance Bypass Switch
- RS-232 Interface
- LCD Display for advanced user indications and controls
- Audible Alarm
- Remote Emergency Power Off (REPO) capability
- Auto-restart capability.

1.4.2 Options

- Communication Interfaces (Provision for connection of SNMP (ethernet or token ring), Modem or Programmable Relay interfaces)
- Provision for External Battery Cabinet
- Output Distribution Panel (Option)
- Isolated Neutral (Option)
- Transformer Cabinet (Option).

1.5 Modes of Operation

1.5.1 Normal (Utility Power)

When the utility power is available and within acceptable limits, the unit supplies filtered and regulated power to the load through the converter (input) and inverter (output). The battery charger maintains a charge on the battery.

1.5.2 On Battery

If the utility power falls outside of acceptable limits (usually low voltage), the battery will supplement the power being supplied by the converter. The converter will continue to operate if utility power is available. Using both sources provides longer battery time in brownout conditions. The UPS battery is designed to supply power to a full rated load during a power failure. Optional battery cabinets are available for extended run times.

1.5.3 Battery Recharge

Upon return of acceptable utility power after battery operation, the battery charger begins to charge the batteries.

The battery charger compensates for battery temperature. In addition, the charger has two recharge rates, user-selectable through the LCD display.

The fast or “turbo” rate will recharge the batteries to 95% capacity within 10 times the discharge duration. The “slow” (default) rate will recharge the batteries to 95% capacity within 20 times the discharge duration.

1.5.4 On Bypass

The UPStation S3 comes with a fully rated Static Transfer Switch. This automatic switch will supply the load with utility power in the event of a UPS malfunction.

Static Transfer Switch: In the event of overload conditions or inverter failure, the static transfer switch will transfer the load to bypass. When the overload is removed, the load will be automatically retransferred to inverter.

Maintenance Bypass: The bypass path for power to the critical load can be manually selected by the user if there is a need to route power around the UPS in case of a UPS fault or if maintenance is to be done on the UPS. User selection of the maintenance bypass is made by a switch behind the front panel door in the lower left front of the UPS Module. When activated, the unit will transfer the load to bypass. The UPS load will remain on maintenance bypass until unselected by the user.

1.5.5 Remote Emergency Off

Each unit includes a Terminal Block in the unit to enable Remote Emergency Power Off (REPO) from a customer-supplied switch. Activating the emergency off will turn off the Converter, Inverter, and Static Transfer Switch. The voltage to the logic will still be maintained.

To connect to the REPO feature, refer to **Figure 15** and **Figure 16**. If utilizing a normally open switch, connect wire leads from the switch to terminals 1 and 2 of the terminal block. If utilizing a normally closed switch, remove the wire jumper between terminals 2 and 3, and connect the wire leads across terminals 2 and 3.



WARNING

THE LOCAL EPO AND REMOTE REPO DO NOT TURN OFF THE MAINTENANCE BYPASS IF THE LOAD IS ON MAINTENANCE BYPASS. POWER WILL NOT BE REMOVED BY EPO OR REPO. THE USER MUST ALSO SHUT OFF POWER FROM THE FEEDER TO THE UPS.



CAUTION

Make sure there is no voltage on the REPO.

2.0 INSTALLATION

2.1 Safety Precautions

Read this manual thoroughly, paying special attention to the sections that apply to you before working with the UPS.



WARNING

THE BATTERY IS ALWAYS ENERGIZED.

Under typical operation and with all UPS doors closed, only normal safety precautions are necessary. The area around the UPS system and battery should be kept free from puddles of water, excess moisture, or debris.

Special safety precautions are required for procedures involving handling, installation and maintenance of the UPS system or battery. Observe precautions in **2.0 - Installation** before handling or installing the UPS system. Observe precautions in **5.0 - Maintenance**, before as well as during performance of all maintenance procedures. Observe all battery safety precautions before working on or near the battery.

This equipment contains several circuits that are energized with high voltage. Only test equipment designated for troubleshooting should be used. This is particularly true for oscilloscopes. Always check with an AC and DC voltmeter to ensure safety before making contact or using tools. Even when the power is turned Off, dangerously high potentials may exist at the capacitor banks. Observe all battery precautions when near the battery for any reason.

ONLY qualified service personnel should perform maintenance on the UPS system.

When performing maintenance with any part of the equipment under power, service personnel and test equipment should be standing on rubber mats. The service personnel should wear insulating shoes for isolation from direct contact with the floor (earth ground).

Unless power is removed from the equipment, one person should never work alone. A second person should be standing by to assist and summon help in case an accident should occur. This is particularly true when work is performed on the battery.

2.2 UPS Installation



ATTENTION INSTALLERS

Proper wire sizing (service ratings) and phase rotation are critical to the successful installation of this product. Refer to Table 1 - Site Planning Data.

Make sure you have installed properly sized external overcurrent protection. Refer to Table 1.

Proper planning will speed UPS unloading, location and connection. Make sure there is adequate clearance for the UPS module door to open full swing. Check for a minimum of 12 in. clearance above both the battery and UPS modules for exhaust air to flow without restriction. Also allow adequate clearance at bottom front of each cabinet for unrestricted intake air to flow. Make sure room has adequate ventilation and cooling. Install the UPS in a clean and dry location.

Install the UPS according to drawings (**Figure 13 to Figure 21 and Table 2 through Table 4**) and the following procedures. After installation is complete, contact Liebert Global Services at **1-800-543-2378** to schedule checkout and start-up assistance.

A Liebert authorized representative must perform an initial system start-up to ensure proper UPS operation. Equipment warranties will be voided unless system start-up is performed by a Liebert authorized representative.



WARNING

READ THIS MANUAL THOROUGHLY BEFORE ATTEMPTING TO WIRE OR OPERATE THE UNIT. IMPROPER INSTALLATION IS THE MOST SIGNIFICANT CAUSE OF UPS START-UP PROBLEMS. TO REDUCE THE RISK OF FIRE, CONNECT ONLY TO A CIRCUIT PROVIDED WITH BRANCH CIRCUIT OVERCURRENT PROTECTION SIZED IN ACCORDANCE WITH NEC, ANSI/NFPA 70. FOR MAXIMUM BRANCH CIRCUIT OVERCURRENT PROTECTION SIZING, REFER TO THE DATA IN TABLE 1 - SITE PLANNING DATA (AC INPUT, REQUIRED EXTERNAL OVERCURRENT PROTECTION).

DO NOT INSTALL THE EQUIPMENT NEAR ANY GAS OR ELECTRIC HEATERS OR UNDER WATER LINES OR AIR CONDITIONING EQUIPMENT. INSTALL THE EQUIPMENT IN A RESTRICTED LOCATION TO PREVENT ACCESS BY UNAUTHORIZED PERSONNEL.

THIS EQUIPMENT COMPLIES WITH THE REQUIREMENTS IN PART 15 OF FCC RULES FOR A CLASS A COMPUTING DEVICE. OPERATION OF THIS EQUIPMENT IN A RESIDENTIAL AREA MAY CAUSE INTERFERENCE TO RADIO AND TV RECEPTION, REQUIRING THE OPERATOR TO TAKE WHATEVER STEPS NECESSARY TO CORRECT THE INTERFERENCE.

2.2.1 Installation Considerations

1. Utilize the shortest output distribution cable runs possible at the installation site, consistent with logical equipment arrangement and in compliance with NEC and local electrical codes. Allow space for future equipment additions.
2. Recommended ambient temperature for operation is 20 to 30 degrees Celsius (68 to 86 degrees Fahrenheit). Relative humidity must be less than 95% non-condensing. In altitudes above 2000 meters (6,560 feet), the UPS rating will be reduced.
3. The route and foundation to the installation site must be capable of supporting the weight of cabinets and moving equipment. Refer to **Table 1** for specific information about cabinet weights.
4. Plan the route to ensure unit will pass through all elevators, corners, and doorways to prevent damage.
5. Heat output of UPS equipment is significant. Be sure environmental conditioning systems can accommodate this heat load, even during utility outages. Refer to **Table 1** for more specific information.

2.2.2 Unloading and External Inspection

In most cases the UPS and its battery module are shipped bolted together on the same pallet. Some larger configurations use shipping splits and may come on 2 or more pallets. Refer to **Figure 20** and **Figure 21**. Move the cabinets as close as possible to the intended location before removing from the pallet. If the unit arrives as a shipping split, your Liebert Global Services personnel will reconnect the cabinets and cabinet wiring as part of their start up service.



WARNING

DO NOT REMOVE THE SUPPORTING BANDS UNTIL YOU INTEND TO REMOVE UNIT FROM THE PALLET. SHIPPING BANDS ARE USED TO SECURE THE UNIT TO THE PALLET. EXTREME CARE IS NECESSARY DURING MOVING. TEST LIFT AND BALANCE THE CABINETS BEFORE TRANSPORTING. MAINTAIN MINIMUM TILT FROM VERTICAL AT ALL TIMES. DO NOT TILT BEYOND 15 DEGREES FROM THE VERTICAL AT ANY TIME.

1. Inspect equipment and shipping container(s) for any signs of damage or mishandling. Do not attempt to install the system if damage is apparent. If any damage is noted, file a damage claim with the shipping agency within 24 hours, and contact Liebert Global Services at **1-800-543-2378** to inform them of the damage claim and the condition of the equipment.
2. Compare contents of shipment with the bill of lading. Report any missing items to the carrier and to Liebert Global Services immediately.
3. Check nameplate on the inside of cabinet front door to verify model number, kVA rating, and input/output voltage corresponds with the one specified. Record model and serial number in the front of this manual. A record of this information is necessary should servicing become required.

2.2.3 Internal Inspection of the UPS System

1. Verify that all items have been received.
2. If spare parts were ordered, verify arrival.
3. Check for shipping damage internally.
4. Check for any loose connections or unsecured components in the UPS Module.
5. Check for installation of safety shields on the UPS module. There should not be any exposed terminals when the cabinet doors are opened.
6. Check for any unsafe feature that may be a potential safety hazard.

2.2.4 Equipment Location



WARNING

EACH UPS MODULE AND MATCHING BATTERY CABINET WEIGHS BETWEEN 1100 AND 2700 POUNDS, DEPENDING ON MODEL. EXERCISE EXTREME CARE WHEN HANDLING TO AVOID EQUIPMENT DAMAGE OR INJURY TO PERSONNEL. A FORKLIFT OR OTHER ADEQUATE MATERIAL-HANDLING DEVICE SHOULD BE USED FOR UNLOADING, MOVING AND POSITIONING THE CABINETS.



INSTALLATION TIP

Install the leveling feet while the unit is on the forklift or other material handling equipment. Leveling feet cannot be installed with the unit sitting on its caster wheels.

1. Use a forklift or other material handling device to move the cabinets as close as possible to the final installation site. For units with a battery or transformer cabinet, the forklift must be used on the left (heavier) side.
2. Casters are provided on the unit to aid in final positioning.
3. The unit is equipped with leveling feet, shipped inside the unit, which should be used to level the unit after it is set in place. Open front door (release locking screw). Install leveling feet while supporting the unit with the forklift or other lifting device.
4. As with all electrical equipment, installation and serviceability will be easier if access is provided on all sides of the equipment. Minimum access requirements are 3 feet front, 1 foot top.
5. Verify adequate clearance for cabinet doors to open. See drawings and local codes (4 feet is recommended).
6. Verify adequate clearance above cabinets allowing unrestricted exhaust air to flow (12 inches minimum).
7. Verify UPS system is installed in a clean, cool and dry location.

2.3 Batteries

Battery Safety Precautions: Servicing of batteries should be performed or supervised by personnel knowledgeable of batteries and the required precautions. Keep unauthorized personnel away from batteries. Refer to **5.0 - Maintenance** for additional safety precautions regarding batteries.

When replacing batteries, use the same number and type of batteries.



WARNING

LEAD-ACID BATTERIES CONTAIN HAZARDOUS MATERIALS. BATTERIES MUST BE HANDLED, TRANSPORTED, AND RECYCLED OR DISCARDED IN ACCORDANCE WITH FEDERAL, STATE AND LOCAL REGULATIONS. BECAUSE LEAD IS A TOXIC SUBSTANCE, LEAD-ACID BATTERIES SHOULD BE RECYCLED RATHER THAN DISCARDED. DO NOT DISPOSE OF BATTERY OR BATTERIES IN A FIRE. THE BATTERY MAY EXPLODE. DO NOT OPEN OR MUTILATE THE BATTERY OR BATTERIES. RELEASED ELECTROLYTE IS HARMFUL TO THE SKIN AND EYES. IT MAY BE TOXIC. FOR ASSISTANCE WITH BATTERY DISPOSAL OR RECYCLING CONTACT LIEBERT GLOBAL SERVICES AT 1-800-543-2378.



WARNING

A BATTERY CAN PRESENT A RISK OF ELECTRICAL SHOCK OR BURN FROM HIGH SHORT CIRCUIT CURRENT. THE FOLLOWING PRECAUTIONS SHOULD BE OBSERVED WHEN WORKING ON BATTERIES.

ATTENTION: UNE BATTERIE PEUT PRÉSENTER UN RISQUE DE CHOC ÉLECTRIQUE, OU DE BRÛLURE PAR TRANSFERT D'ÉNERGIE. SUIVRE LES PRÉCAUTIONS QUI S'IMPOSENT.

- 1. REMOVE WATCHES, RINGS, OR OTHER METAL OBJECTS.**
- 2. USE TOOLS WITH INSULATED HANDLES.**
- 3. WEAR RUBBER GLOVES AND BOOTS.**
- 4. DO NOT LAY TOOLS OR METAL PARTS ON TOP OF BATTERIES.**
- 5. DISCONNECT CHARGING SOURCE PRIOR TO CONNECTING OR DISCONNECTING BATTERY TERMINALS.**
- 6. DETERMINE IF BATTERY IS INADVERTENTLY GROUNDED. IF INADVERTENTLY GROUNDED, REMOVE SOURCE OF GROUND. CONTACT WITH ANY PART OF A GROUNDED BATTERY CAN RESULT IN ELECTRICAL SHOCK. THE LIKELIHOOD OF SUCH SHOCK WILL BE REDUCED IF SUCH GROUNDS ARE REMOVED DURING INSTALLATION AND MAINTENANCE.**

LEAD-ACID BATTERIES CAN PRESENT A RISK OF FIRE BECAUSE THEY GENERATE HYDROGEN GAS. THE BATTERIES WILL NOT GENERATE HYDROGEN IN NORMAL OPERATION. ONLY IN EXTREME CONDITIONS OF TEMPERATURE OR OVER-CHARGE WILL THE BATTERIES GAS. THE FOLLOWING PROCEDURES SHOULD BE FOLLOWED:

- 1. DO NOT SMOKE WHEN NEAR BATTERIES.**
- 2. DO NOT CAUSE FLAME OR SPARK IN BATTERY AREA.**
- 3. DISCHARGE STATIC ELECTRICITY FROM BODY BEFORE TOUCHING BATTERIES BY FIRST TOUCHING A GROUNDED METAL SURFACE.**

For most applications the batteries on the UPStation S3 come in a matching bolted-on battery cabinet to the UPS module. There is no installation of batteries required. Battery cabinets supplied by Liebert and not bolted to the unit will come with instructions on how to connect the battery cabinet to the UPS module. Bolted-together Battery cabinets shipped on shipping splits will be connected by Liebert Global Services as part of the start up service.

For safety reasons the batteries come with the circuit breaker in the off position. As an additional safety precaution during shipment, a battery inter-cell connection is disconnected. Even with this disconnected, hazardous voltages are present.

2.4 Electrical Wiring



WARNING

ALL POWER CONNECTIONS MUST BE COMPLETED BY A LICENSED ELECTRICIAN WHO IS EXPERIENCED IN WIRING THIS TYPE OF EQUIPMENT. WIRING MUST BE INSTALLED IN ACCORDANCE WITH ALL APPLICABLE NATIONAL AND LOCAL ELECTRICAL CODES. IMPROPER WIRING MAY CAUSE DAMAGE TO THE EQUIPMENT OR INJURY TO PERSONNEL. VERIFY THAT ALL INCOMING HIGH AND LOW VOLTAGE POWER CIRCUITS ARE DE-ENERGIZED AND LOCKED OUT BEFORE INSTALLING CABLES OR MAKING ANY ELECTRICAL CONNECTIONS.

Refer to **Table 1 - Site Planning Data** and installation drawings (**Figure 1** through **Figure 21**). Refer to **Table 2** through **Table 4** for wire termination data. Also, refer to equipment nameplate for the model number, rating, and voltage so correct values are used from the tables associated with the drawings.

2.4.1 UPS Wire Size Guidelines

Proper wire sizing must be based on numerous site-specific conditions. **Table 2**, a reprint of Table 310-16 of the NEC (National Electrical Code, NFPA 70) is included with permission of the National Fire Protection Association as a convenience to assist in determining the minimum size wires for your UPS application. Refer to notes **1** through **6** below, the present edition of the NEC, and all applicable local codes for your particular site requirements.

1. Refer to the Liebert chart or drawing that shows the Ampacities for your UPS.
2. Input ampacity must be based on 125% of input current at full rated load plus 100% of battery charging current.
3. Be sure to refer to all requirements within Article 310 of the NEC.
4. Minimum sized grounding conductors are to be per NEC 250-95.
5. Neutral conductors are to be sized per NEC 310-16, note 10.
6. The UPS system must be installed in accordance with the present edition of the NEC and all local codes, including the codes of foreign countries where applicable.

2.4.2 Power & Control Wiring



WARNING

ALL POWER SHOULD BE TURNED OFF BEFORE ANY CABLES OR WIRES ARE INSTALLED OR CONNECTED. A QUALIFIED PERSON SHOULD CHECK TO INSURE THE POWER IS IN FACT “OFF”.

1. Verify that power wiring is run in individual, separate conduit or cable tray. Verify that control wiring is run in individual separate steel conduit.
2. All Input wiring must be run in its own conduit.
3. All Output wiring must be run in its own conduit.
4. All Control wiring must be run in its own conduit.



CAUTION

Power and control wiring must be separated!



INSTALLATION TIP

Make sure that wiring is installed with a clockwise phase rotation of all power wiring, Phase A leads Phase B leads Phase C.

5. Observe local, state and national electrical codes. Verify utility power and its over-current protection rating will accommodate the UPS INPUT rating, including battery recharging.
6. A safety ground wire must be run from building ground to ground point in the UPS Module Cabinet. The grounding conductor shall comply with the following conditions of installation:
 - a. An insulated grounding conductor that is identical in size, insulation material, and thickness to the grounded and ungrounded branch-circuit supply conductors except that it is green with or without one or more yellow stripes is to be installed as part of the branch circuit that supplies the unit or system.
 - b. The grounding conductor described in **Item a** is to be grounded to earth at the service equipment or, if supplied by a separately derived system, at the supply transformer or motor-generator set.
 - c. The attachment-plug receptacles in the vicinity of the unit or system are all to be of a grounding type, and the grounding conductors serving these receptacles are to be connected to earth ground at the service equipment.
7. Observe clockwise phase rotation of all power wiring, Phase A leads Phase B leads Phase C. A qualified electrician should check the phase rotation.
8. NEC Class 1 wiring methods are required for control and communication (Class 2) circuits.
9. If the UPS is supplied without a Maintenance Bypass, the output AC disconnect is to be provided by others.

2.4.3 Battery Wiring

Most UPStation S3 modules with either single 12 in. or 24 in. battery cabinets come with the battery cabinets installed to the module and all interconnection cables in place and pre-wired. Larger battery configurations or special configurations may come with the battery cabinet on a separate pallet(s). Liebert Global Services personnel will connect the battery cabinets as part of the start up service.

If you have purchased a Liebert stand alone battery cabinet, it will come with instructions on how to connect it to the UPS module. If the module is to be located apart from the stand-alone, battery cabinet, a qualified electrical contractor will need to supply the conduit and wiring necessary to connect the UPS module to the battery cabinet.



WARNING

A BATTERY INTER-CELL CONNECTION IS DISCONNECTED FOR SAFETY DURING SHIPMENT. DO NOT COMPLETE THESE CONNECTIONS. THE LIEBERT GLOBAL SERVICES REPRESENTATIVE WILL COMPLETE THESE CONNECTIONS AS PART OF START-UP.

If your UPStation S3 is supplied with a freestanding battery cabinet make sure the following guidelines are observed.

Once the unit is located in final position, connect wiring between battery cabinet and UPS module. For freestanding cabinets and other battery systems, DC cables are provided by others.

If utilizing a remote battery supply not provided by Liebert, refer to the battery manufacturer's installation manual for battery installation and maintenance instructions.

If utilizing a remote battery supply not provided by Liebert, appropriately sized overcurrent protection for the battery circuit is to be provided by others.

Remote batteries must be protected by an overcurrent protective device with a voltage rating of 500 volts DC for systems with input voltages above 250 volts AC, or with a voltage rating of 250 volts DC for systems with input voltages below 250 volts AC. All such protective devices shall have a fault current capability of 10,000 Amperes.

Power wiring to the battery cabinet connects positive, negative, and ground power cables from the battery cabinet to the associated UPS.

Connection of the UPS to the battery cabinet serves to both charge and discharge the batteries (when needed).



WARNING

MAKE SURE ALL POWER (AND CONTROL, IF APPLICABLE) WIRING FROM THE UPS IS DE-ENERGIZED AND PROPERLY INSTALLED BEFORE CONNECTING TO THE BATTERY CABINET.

Cables to the battery cabinet should be sized for a maximum 2.0-volt total line loss at the maximum discharge current for the equipment. Refer to **Table 1 - Site Planning Data** for maximum battery discharge current. A qualified licensed electrician can size the wiring for your installation using this information.



CAUTION

Be sure polarity is correct when wiring the battery cabinet to the connected equipment (positive to positive; negative to negative). If polarity is not correct, fuse failures or equipment damage can result.

Call Liebert Global Services at **1-800-543-2378** to schedule installation check-out, final battery inter-cell connections, reconnection of shipping splits, and start-up.



WARNING

DO NOT CONNECT THE DISCONNECT PLUG OR TURN THE BATTERY BREAKER ON UNTIL THE INSTALLATION HAS BEEN INSPECTED BY LIEBERT GLOBAL SERVICES. AN IMPROPERLY INSTALLED UNIT CAN RESULT IN INJURY TO PERSONNEL OR DAMAGE TO EQUIPMENT.

2.4.4 Wiring Connections

Verify the following connections have been made:

1. AC power cables from wye-connected input power source (or optional external maintenance bypass cabinet) to UPS Module Input. (Observe A-B-C phase rotation.)
If the UPStation S3 has line-to-neutral loads connected to the UPS output, the input source must have three phases, plus neutral, plus ground, or have the isolating transformer option installed. If there will be no line-to-neutral loads attached, an input neutral is not required.
2. If the UPS system has arrived with a shipping split, make sure that Liebert Global Services start-up personnel have reconnected the unit.
3. DC power cables (positive and negative) from battery cabinet to UPS module DC bus (observe proper polarity).
If employing a Liebert stand-alone battery cabinet or battery cabinet supplied by others, and when multiple conductors are used from the battery to the UPS module, it is necessary to run the same number of positive (+) and negative (-) cables in the same cable tray or conduit.
4. AC power cables from the UPS output to the critical load distribution. (Observe A-B-C Phase Rotation.)
The output source should have three phases, plus neutral (if line-to-neutral loads will be powered from the UPS output), plus ground.
5. Any additional special control wiring must be run in individual separate conduit.
6. UPS input and output neutral must be connected to only one common point in the UPS. This neutral line must be grounded at the source. If you have selected the Isolated Neutral Option, the input neutral is to be connected to the input neutral terminal and the output neutral should be connected to the separate output neutral terminal. The input neutral line must be grounded at the source. The inverter neutral must be grounded at the UPS.



NOTE

Refer to 4.0 - Features & Options for general descriptions of optional components. If Options are ordered with the UPS or for field installation, a UPStation S3 Options User's Manual (SL-24932) will be supplied. This should be referred to for detailed installation and operation instructions on all options.

2.4.5 Wiring Inspection

1. Verify all power connections are tight.
2. Verify all control wire terminations are tight.
3. Verify all power wires and connections have proper spacing between exposed surfaces, phase-to-phase and phase-to-ground.
4. Verify that all control wires are run in individual, separate, rigid steel conduit.



CAUTION

Failure to observe the above could result in short circuits or possible fire hazard.

Table 2 Table 310-16

Allowable Ampacities of Insulated Conductors Rated 0-2000 Volts, 60° to 90°C (140° to 194°F)¹

Not More than Three Conductors in Raceway or Cable or Earth (Directly Buried), based on Ambient Temperature of 30° (86°F)

Size	Temperature Rating of Conductor. See Table 310-13.						Size
	60°C (140°F)	75°C (167°F)	90°C (194°F)	60°C (140°F)	75°C (167°F)	90°C (194°F)	
AWG kcmil	Types TW† UF†	Types FEPW†, RH,RHW†, THHW†, THW†, THWN†, XHHW†, USE†, ZW†	Types TBS, SA, SIS,FEP†, FEPB†,MI, RHH†, RHW-2 THHN†,THHW†, THW-2,THWN-2, USE-2, XHH, XHHW† XHHW-2,ZW-2	Types TW† UF†	Types RH†, RHW†, THHW†, THW†, THWN†, XHHW†, USE†	Types TBS, SA,SIS, THHN†, THHW†, THW-2, THWN-2, RHH†, RHW-2, USE-2, XHH, XHHW†, XHHW-2, ZW-2	AWG kcmil
	Copper			Aluminum or Copper-Clad Aluminum			
18	14
16	18
14	20†	20†	25†
12	25†	25†	30†	20†	20†	25†	12
10	30	35†	40†	25	30†	35†	10
8	40	50	55	30	40	45	8
6	55	65	75	40	50	60	6
4	70	85	95	55	65	75	4
3	85	100	110	65	75	85	3
2	95	115	130	75	90	100	2
1	110	130	150	85	100	115	1
1/0	125	150	170	100	120	135	1/0
2/0	145	175	195	115	135	150	2/0
3/0	165	200	225	130	155	175	3/0
4/0	195	230	260	150	180	205	4/0
250	215	255	290	170	205	230	250
300	240	285	320	190	230	255	300
350	260	310	350	210	250	280	350
400	280	335	380	225	270	305	400
500	320	380	430	260	310	350	500
600	355	420	475	285	340	385	600
700	385	460	520	310	375	420	700
750	400	475	535	320	385	435	750
800	410	490	555	330	395	450	800
900	435	520	585	355	425	480	900
1000	455	545	615	375	445	500	1000
1250	495	590	665	405	485	545	1250
1500	520	625	705	435	520	585	1500
1750	545	650	735	455	545	615	1750
2000	560	665	750	470	560	630	2000
Correction Factors							
Ambient Temp °C	For ambient temperatures other than 30°C (86°F), multiply the allowable ampacities shown above by the appropriate factor shown below.						Ambient Temp °F
21-25	1.08	1.05	1.04	1.08	1.05	1.04	70-77
26-30	1.00	1.00	1.00	1.00	1.00	1.00	78-86
31-35	.91	.94	.96	.91	.94	.96	87-95
36-40	.82	.88	.91	.82	.88	.91	96-104
41-45	.71	.82	.87	.71	.82	.87	105-113
46-50	.58	.75	.82	.58	.75	.82	114-122
51-55	.41	.67	.76	.41	.67	.76	123-131
56-6058	.7158	.71	132-140
61-7033	.5833	.58	141-158
71-804141	159-176

† Unless otherwise specifically permitted elsewhere in this Code, the overcurrent protection for conductor types marked with an obelisk (†) shall not exceed 15 amperes for No. 14, 20 amperes for No. 12, and 30 amperes for No. 10 copper; or 15 amperes for No. 12 and 25 amperes for No. 10 aluminum and copper-clad aluminum after any correction factors for ambient temperature and number of conductors have been applied.

¹ Reprinted with permission from NFPA 70-1993, the National Electrical Code®, Copyright 1996, National Fire Protection Association, Quincy, MA 02269. This reprinted material is not the complete and official position of the National Fire Protection Association, on the referenced subject which is represented only by the standard in its entirety.

Table 3 UPS Module Power Wiring Termination - Factory Supplied

Connection Type / Wire Size Range					
UPS Module Rating kVA	AC Input	Battery	AC Output	Neutral	Ground
12 - 24	Compression lug #14 to #2/0	Studs 3/8 - 16 x 2 Lugs Required	Compression lug #14 to #2/0	Compression lug #14 to #2/0	Copper Busbar 3.75 x 3.75 x 0.25

Use factory supplied connections for terminations where they are provided. Refer to **Figure 19** for field-supplied wiring termination details. Use commercially available UL listed solderless lugs for the wire size required for your application. Connect wire to the lug using tool and procedure specified by the lug manufacturer.

Table 4 Torque Specifications (Unless Otherwise Labeled)

Nut and Bolt Combinations				
Bolt Shaft Size Inches	Grade 2 Standard		Electrical Connections with Belleville Washers	
	Lb-in	N-m	Lb-in	N-m
1/4	70	8.0	46	5.2
5/16	132	15	60	6.8
3/8	229	26	95	10.7
1/2	476	54	256	28.9

Terminal Block Compression Lugs				
UPS Module Rating kVA	Wiring	Wire Size or Range	Lb-in	N-m
12 - 24	Control	#22 - #14	3.5 to 5.3	0.4 to 0.6
12 - 24	Power	#6 - 350 MCM	50	5.6

Figure 1 One Line Drawing - Single Input Configuration (200/240V In/Out)

TABLE 1

POWER RATING KVA / KW	VOLTAGE VAC	① RECIFIER & BYPASS INPUT			② BATTERY		③ OUTPUT		
		NOM.	BYE.	MAX.	NOMINAL VOLTAGE	MAX DISCHARGE CURRENT	NOMINAL CURRENT	MAXIMUM NEUTRAL CURRENT	RECOMMENDED EXTERNAL OVERCURRENT PROTECTION
12/8.4	200	29	35	42	240 VDC (120 CELLS)	51 A	35 A	61 A	50 A
	208	28	33	40			33 A	57 A	50 A
	220	26	31	38			31 A	54 A	40 A
16/11.2	240	24	29	35	240 VDC (120 CELLS)	67 A	29 A	50 A	40 A
	200	39	46	56			46 A	80 A	60 A
	208	37	45	54			42 A	73 A	60 A
20/14	220	35	42	51	240 VDC (120 CELLS)	84 A	42 A	66 A	50 A
	240	32	38	46			38 A	66 A	50 A
	200	48	58	70			58 A	100 A	80 A
24/16.8	208	46	56	67	240 VDC (120 CELLS)	101 A	56 A	97 A	80 A
	220	43	52	63			52 A	90 A	70 A
	240	39	48	58			48 A	83 A	70 A
NOTES	200	58	69	84	240 VDC (120 CELLS)	6.8, 9, 10	69 A	120 A	100 A
	208	55	67	80			67 A	115 A	100 A
	220	52	63	76			63 A	109 A	80 A
240	47	58	70	47 A	58 A	100 A	80 A		
		1	1	2	4	6.8, 9, 10	1	.11	3.5, 6.7, 8, 9, 10

LEGEND
 --- FIELD SUPPLIED WIRING
 - - - - - FACTORY SUPPLIED WIRING

* EXTERNAL OVERCURRENT PROTECTION BY OTHERS

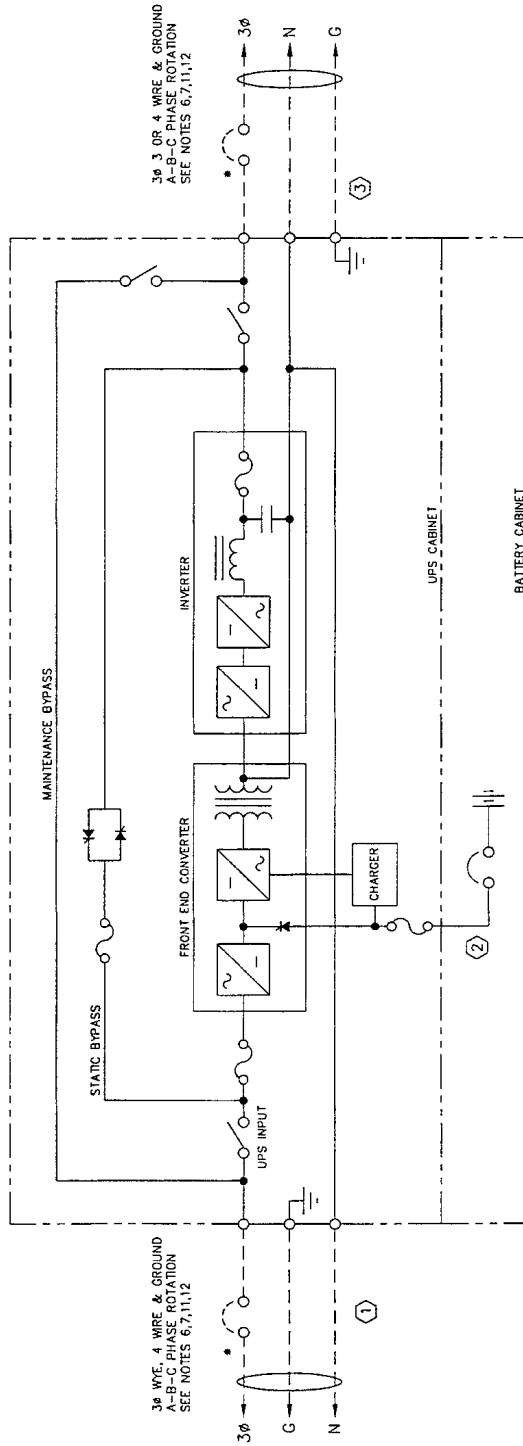

3φ WYE, 4 WIRE & GROUND
 A-B-C PHASE ROTATION
 SEE NOTES 6,7,11,12

3φ 3 OR 4 WIRE & GROUND
 A-B-C PHASE ROTATION
 SEE NOTES 6,7,11,12

NOTES:

- NOMINAL (NOM) CURRENT IS BASED ON FULL RATED OUTPUT LOAD.
- MAXIMUM (MAX) CURRENT IS SHORT DURATION FOR BATTERY RECHARGE AND OVERLOAD CONDITIONS.
- UPS INPUT AND OUTPUT CABLES MUST BE RUN IN SEPARATE CONDUITS.
- NOMINAL BATTERY VOLTAGE IS SHOWN AT 2.0 VOLTS/CELL PER NEC 480-2.
- RECOMMENDED AC OVERCURRENT PROTECTION REPRESENTS NONCONTINUOUS PLUS 125% OF NOMINAL FULL LOAD CURRENT (CONTINUOUS) PER NEC 220-3(G).
- MINIMUM SIZED GROUNDING CONDUCTORS TO BE PER NEC 250-95. PARITY SIZED GROUND CONDUCTORS RECOMMENDED.
- FOR 3 WIRE, 3 PHASE LOADS ONLY, AN INPUT NEUTRAL CONDUCTOR IS NOT REQUIRED. SEE NOTE 12. FOR LINE TO NEUTRAL LOADS, A NEUTRAL IS REQUIRED FROM THE INPUT SOURCE.
- ALL WIRING IS TO BE IN ACCORDANCE WITH NATIONAL AND LOCAL ELECTRICAL CODES.
- TOP OR BOTTOM CABLE ENTRY THROUGH REMOVABLE ACCESS PLATES. CUT PLATE TO SUIT CONDUIT SIZE THEN REPLACE.
- CONTROL WIRING AND POWER WIRING MUST BE RUN IN SEPARATE CONDUITS.
- NEC 310-16, NOTE 10(C), STATES THAT THE NEUTRAL CONDUCTOR IS TO BE CONSIDERED A CURRENT-CARRYING CONDUCTOR. A FULLY-RATED NEUTRAL WIRE IS REQUIRED. HOWEVER, FOR SOME NON-LINEAR LOADS, NEUTRAL CURRENT MAY EXCEED LINE CURRENT. FOR WORST-CASE CONDITIONS, THE WIRE SIZE FOR THE NEUTRAL CONDUCTOR SHOULD BE BASED ON THE MAXIMUM NEUTRAL CURRENT SHOWN IN TABLE 1 ABOVE. AMPACITIES OF CONDUCTORS SHOULD BE ADJUSTED PER NEC 310-16, NOTE 8, WHEN APPROPRIATE.
- FOR A 3 PHASE, 3 WIRE (SOLIDLY GROUND WYE) INPUT SOURCE, THE UPS INPUT NEUTRAL CONDUCTOR IS NOT REQUIRED. HOWEVER, A LOCAL GROUNDING ELECTRODE CONDUCTOR (GEC) MUST BE INSTALLED PER NEC 250-4(B). FOR A 3 PHASE, 4 WIRE OUTPUT, AN INPUT NEUTRAL CONDUCTOR IS REQUIRED. FOR OTHER TYPES OF SOURCES, A DELTA TO WYE ISOLATION TRANSFORMER MAY BE REQUIRED. CONSULT WITH FACTORY REFER TO NEC ARTICLE 250 & LOCAL CODES FOR PROPER GROUNDING PRACTICES.

TITLE	ONE-LINE DRAWING UPSTATION S3 12-24 KVA SINGLE-INPUT CONFIGURATION 200-240V INPUT / OUTPUT
DRG. NO.	US312010
DATE	04-04-97
CONFIG.	

Liabert
 1000 S. BAYVIEW, COVINGTON, LA 70011

Figure 2 One Line Drawing - Dual Input Configuration (200/240V In/Out)

TABLE 1

POWER RATING KVA / KW	VOLTAGE VAC	AC RECTIFIER INPUT		NOMINAL VOLTAGE	MAX DISCHARGE CURRENT	AC OUTPUT & BYPASS INPUT		
		CURRENT NOM.	RECOMMENDED EXTERNAL OVERCURRENT PROTECTION			NOMINAL CURRENT	RECOMMENDED EXTERNAL OVERCURRENT PROTECTION	
12/8.4	200	29	50 A	240 VDC (120 CELLS)	51 A	35 A	61 A	
	208	26	40 A			37 A	54 A	
	220	33	40 A			40 A	50 A	
	240	24	40 A			28 A	40 A	
16/11.2	200	39	60 A	240 VDC (120 CELLS)	67 A	46 A	80 A	
	208	37	60 A			44 A	76 A	
	220	43	60 A			47 A	80 A	
	240	35	50 A			32 A	60 A	
20/14	200	48	80 A	240 VDC (120 CELLS)	84 A	58 A	100 A	
	208	46	70 A			56 A	90 A	
	220	54	70 A			52 A	80 A	
	240	39	60 A			48 A	70 A	
24/16.8	200	58	100 A	240 VDC (120 CELLS)	101 A	69 A	120 A	
	208	55	80 A			61 A	108 A	
	220	65	80 A			61 A	108 A	
	240	47	60 A			58 A	80 A	
NOTES		1	2	3,5,6,7,8,9,10	4	6,8,9,10	11	3,5,6,7,8,9,10

LEGEND
 - - - - - FIELD SUPPLIED WIRING
 _____ FACTORY SUPPLIED WIRING
 * EXTERNAL OVERCURRENT PROTECTION BY OTHERS

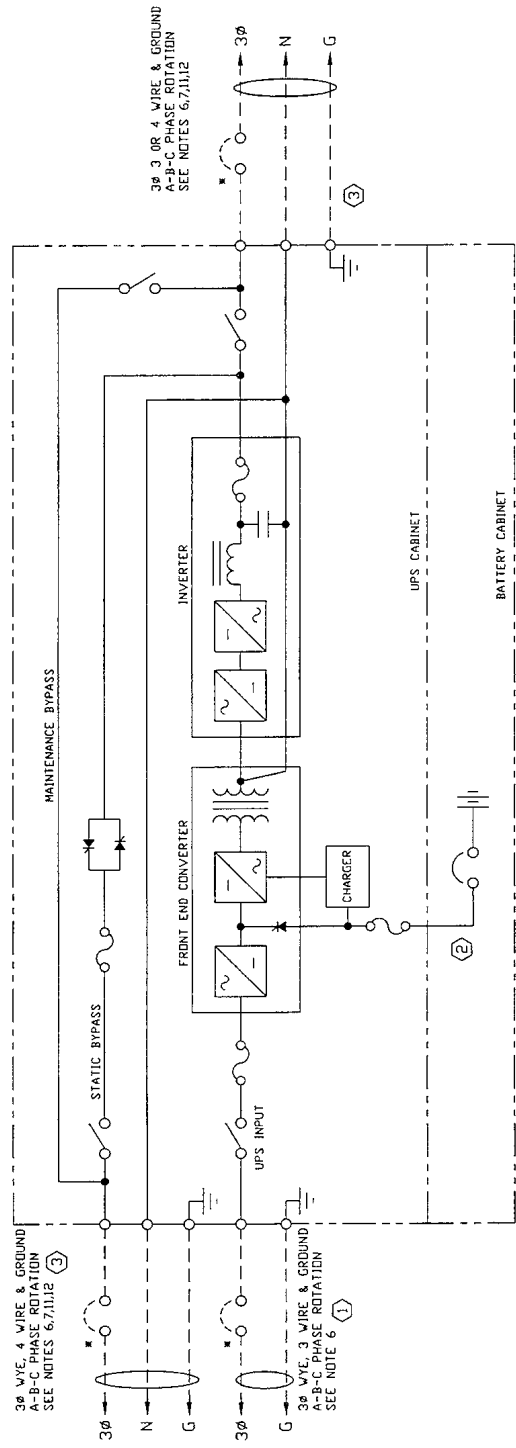

TITLE		DRG. NO.	
ONE-LINE DRAWING UPSTATION S3 12-24 KVA DUAL-INPUT CONFIGURATION 200-240V INPUT / OUTPUT		US312020	
DATE		CONFIG.	
04-03-97			

Liebert
1510 E. COLLEEN AVENUE, P.O. BOX 21116, COLUMBIANA, OHIO 43061

- NOTES:**
- NOMINAL (NDC) CURRENT IS BASED ON FULL RATED OUTPUT LOAD.
 - MAXIMUM (MAX) CURRENT IS SHORT DURATION FOR BATTERY RECHARGE AND OVERLOAD CONDITIONS.
 - UPS INPUT AND OUTPUT CABLES MUST BE RUN IN SEPARATE CONDUITS.
 - NOMINAL BATTERY VOLTAGE IS SHOWN AT 20 VOLTS/CELL PER NEC 480-2.
 - RECOMMENDED AC OVERCURRENT PROTECTION REPRESENTS NONCONTINUOUS PLUS 125% OF NOMINAL FULL LOAD CURRENT (CONTINUOUS) PER NEC 240-3(g).
 - MINIMUM SIZED GROUNDING CONDUCTORS TO BE PER NEC 250-95. PARITY SIZED GROUND CONDUCTORS RECOMMENDED.
 - FOR 3 WIRE, 3 PHASE LOADS ONLY, AN INPUT NEUTRAL CONDUCTOR IS NOT REQUIRED. SEE NOTE 12. FOR LINE TO NEUTRAL LOADS, A NEUTRAL IS REQUIRED FROM THE INPUT SOURCE.
 - ALL WIRING IS TO BE IN ACCORDANCE WITH NATIONAL AND LOCAL ELECTRICAL CODES.
 - TOP OR BOTTOM CABLE ENTRY THROUGH REMOVABLE ACCESS PLATES. CUT PLATE TO SUIT CONDUIT SIZE THEN REPLACE.
 - CONTROL WIRING AND POWER WIRING MUST BE RUN IN SEPARATE CONDUITS.
 - NEC 310-16, NOTE 10(C), STATES THAT THE NEUTRAL CONDUCTOR IS TO BE CONSIDERED A CURRENT-CARRYING CONDUCTOR. A FULLY-RATED NEUTRAL WIRE IS REQUIRED. HOWEVER, FOR SOME NON-LINEAR LOADS, NEUTRAL CURRENT MAY EXCEED LINE CURRENT. FOR WORST-CASE CONDITIONS, THE WIRE SIZE FOR THE NEUTRAL CONDUCTOR SHOULD BE BASED ON THE MAXIMUM NEUTRAL CURRENT SHOWN IN TABLE 1 ABOVE. AMPACITIES OF CONDUCTORS SHOULD BE ADJUSTED PER NEC 310-16, NOTE 8, WHEN APPROPRIATE.
 - FOR A 3 PHASE, 3 WIRE (SOLIDLY GROUNDED WYE) INPUT SOURCE, THE UPS NEUTRAL OUTPUT MUST BE BONDED TO GROUND AND A LOCAL GROUNDING ELECTRODE CONDUCTOR MUST BE INSTALLED (NEC 250-26).
 - FOR A 3 PHASE, 4 WIRE OUTPUT, AN INPUT NEUTRAL CONDUCTOR IS REQUIRED. FOR OTHER TYPES OF SOURCES, A DELTA TO WYE ISOLATION TRANSFORMER MAY BE REQUIRED. CONSULT WITH FACTORY. REFER TO NEC ARTICLE 250 & LOCAL CODES FOR PROPER GROUNDING PRACTICES.

Figure 3 One Line Drawing - Single Input Configuration With Neutral Isolation (200/240V In/Out)

LEGEND
 --- FIELD SUPPLIED WIRING
 --- FACTORY SUPPLIED WIRING
 * EXTERNAL OVERCURRENT PROTECTION BY OTHERS

TABLE 1

POWER RATING KVA / KW	VOLTAGE VAC	① RECTIFIER & BYPASS INPUT CURRENT (AMPS)			② RECOMMENDED EXTERNAL OVERCURRENT PROTECTION		BATTERY		③ OUTPUT			
		NOM.	BYP.	MAX.	NOMINAL VOLTAGE	MAX DISCHARGE CURRENT	NOMINAL CURRENT	MAXIMUM NEUTRAL CURRENT	RECOMMENDED OVERCURRENT PROTECTION			
12/8.4	200	28	35	42	50 A	240 VDC	35 A	61 A	50 A			
	208	28	33	40	50 A	(120 CELLS)	31 A	54 A	50 A			
	220	26	31	38	50 A		29 A	50 A	40 A			
	240	24	29	35	50 A							
16/11.2	200	39	46	56	70 A	240 VDC	46 A	89 A	80 A			
	208	37	44	54	70 A	(120 CELLS)	42 A	73 A	80 A			
	220	35	42	51	70 A		38 A	66 A	50 A			
	240	32	38	46	60 A							
20/14	200	48	58	70	100 A	240 VDC	58 A	100 A	80 A			
	208	46	56	67	100 A	(120 CELLS)	56 A	97 A	80 A			
	220	43	53	64	90 A		48 A	80 A	70 A			
	240	39	48	58	70 A							
24/16.8	200	58	69	84	100 A	240 VDC	69 A	120 A	100 A			
	208	55	67	80	100 A	(120 CELLS)	67 A	115 A	100 A			
	220	52	63	76	100 A		63 A	109 A	80 A			
	240	47	58	70	100 A		58 A	100 A	80 A			
NOTES	1 1 2		3,5,6,7,8,9,10		4		6,8,9,10		11		3,5,6,7,8,9,10	

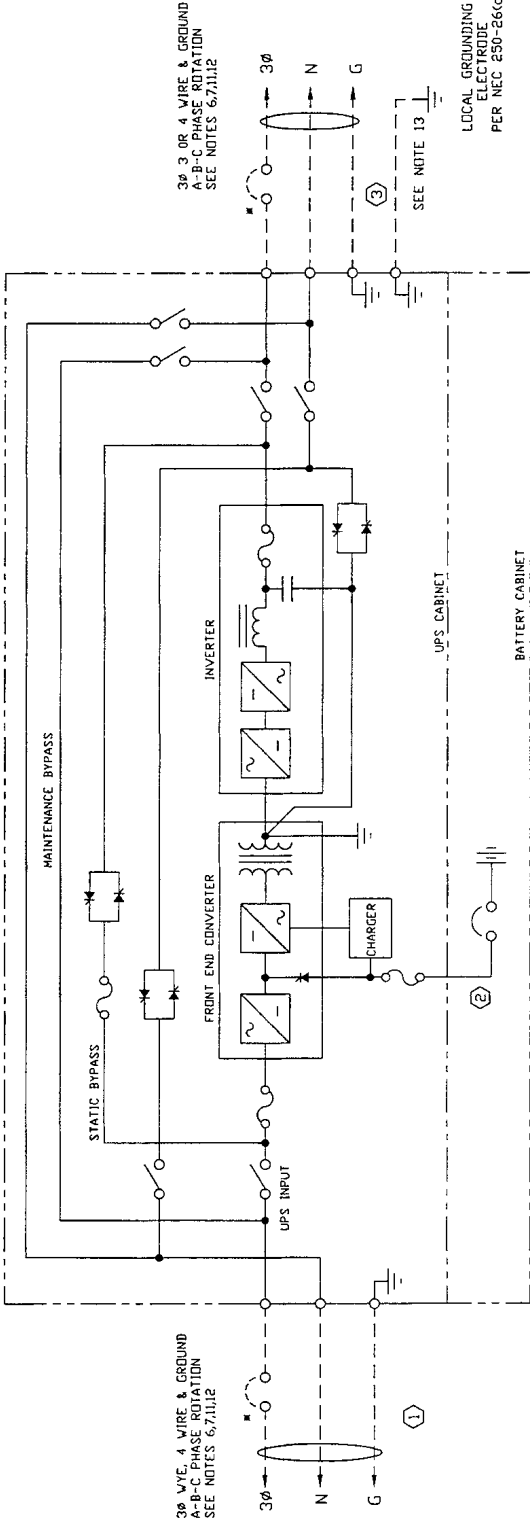

TITLE: ONE-LINE DRAWING
 UPSTATION S3 12-24 KVA
 SINGLE-INPUT CONFIGURATION
 WITH NEUTRAL ISOLATION
 200-240V INPUT / OUTPUT

DRG. NO.: US312030
 DATE: 04-04-97
 CONFIG.

Liebert
 1050 WILSON DRIVE, P.O. BOX 8786, COLUMBIA, OHIO 43229

- NOTES:
1. NOMINAL (NOM) CURRENT IS BASED ON FULL RATED OUTPUT LOAD.
 2. MAXIMUM (MAX) CURRENT IS SHORT DURATION FOR BATTERY RECHARGE AND OVERLOAD CONDITIONS.
 3. UPS INPUT AND OUTPUT CABLES MUST BE RUN IN SEPARATE CONDUITS.
 4. NOMINAL BATTERY VOLTAGE IS SHOWN AT 2.0 VOLTS/CELL PER NEC 480-2.
 5. RECOMMENDED AC OVERCURRENT PROTECTION REPRESENTS NONCONTINUOUS PLUS 125% OF NOMINAL FULL LOAD CURRENT (CONTINUOUS) PER NEC 220-3(c).
 6. MINIMUM SIZED GROUNDING CONDUCTORS TO BE PER NEC 250-95. PARITY SIZED GROUND CONDUCTORS RECOMMENDED.
 7. FOR 3 WIRE, 3 PHASE LOADS ONLY, AN INPUT NEUTRAL CONDUCTOR IS NOT REQUIRED; TO WYE ISOLATION TRANSFORMER MAY BE REQUIRED. CONSULT WITH FACTORY. REFER TO NEC ARTICLE 250 & LOCAL CODES FOR PROPER GROUNDING PRACTICES.
 8. ALL WIRING IS TO BE IN ACCORDANCE WITH NATIONAL AND LOCAL ELECTRICAL CODES.
 9. TOP OR BOTTOM CABLE ENTRY THROUGH REMOVABLE ACCESS PLATES. CUT PLATE TO SUIT CONDUIT SIZE THEN REPLACE.
 10. CONTROL WIRING AND POWER WIRING MUST BE RUN IN SEPARATE CONDUITS.
 11. NEC 310-16, NOTE 10(C), STATES THAT THE NEUTRAL CONDUCTOR IS TO BE CONSIDERED A CURRENT-CARRYING CONDUCTOR. A FULLY-RATED NEUTRAL WIRE IS REQUIRED. HOWEVER, FOR SOME NON-LINEAR LOADS, NEUTRAL CURRENT MAY EXCEED LINE CURRENT. FOR WIRE-SIZED CONDITIONS, THE MAXIMUM NEUTRAL CURRENT CONDUCTOR SHOULD BE BASED ON THE MAXIMUM NEUTRAL CURRENT. THE NEUTRAL CONDUCTOR SIZE OF THE WIRE CONDUCTORS SHOULD BE ADJUSTED PER NEC 310-16, NOTE 8, WHEN APPROPRIATE.
 12. FOR A 3 PHASE, 4 WIRE OUTPUT, AN INPUT NEUTRAL CONDUCTOR IS REQUIRED. FOR SOURCES OTHER THAN A SOLIDLY GROUNDED WYE, A DELTA TO WYE ISOLATION TRANSFORMER MAY BE REQUIRED. CONSULT WITH FACTORY. REFER TO NEC ARTICLE 250 & LOCAL CODES FOR PROPER GROUNDING PRACTICES.
 13. WITH THE NEUTRAL ISOLATION OPTION, THE UPS OUTPUT IS A SEPARATELY DERIVED SOURCE. PROVIDE GROUNDING ELECTRODE CONDUCTOR SIZED PER NEC TABLE 250-94.

Figure 4 One Line Drawing - Dual Input Configuration With Neutral Isolation (200/240V In/Out)

LEGEND
 --- FIELD SUPPLIED WIRING
 --- FACTORY SUPPLIED WIRING
 * EXTERNAL OVERCURRENT PROTECTION BY OTHERS

POWER RATING KVA / KW	VOLTAGE VAC	① AC RECTIFIER INPUT		RECOMMENDED OVERCURRENT PROTECTION	② BATTERY		③ AC OUTPUT & BYPASS INPUT	
		NOM.	MAX.		NOMINAL VOLTAGE	MAX DISCHARGE CURRENT	NOMINAL CURRENT	MAXIMUM NEUTRAL CURRENT
12/8.4	200	28	36	50 A	240 VDC (120 CELLS)	51 A	35 A	61 A
	208	28	35	50 A			57 A	50 A
	220	26	33	40 A			54 A	40 A
16/11.2	200	39	48	60 A	240 VDC (120 CELLS)	67 A	46 A	80 A
	208	37	46	60 A			76 A	60 A
	220	35	43	60 A			73 A	60 A
20/14	200	48	58	80 A	240 VDC (120 CELLS)	84 A	58 A	100 A
	208	46	56	70 A			97 A	80 A
	220	43	54	70 A			95 A	70 A
24/16.8	200	58	73	100 A	240 VDC (120 CELLS)	101 A	69 A	120 A
	208	55	69	100 A			115 A	100 A
	220	52	65	80 A			109 A	80 A
NOTES		1	2	3,5,6,7,8,9,10	4	6,8,9,10	1	11

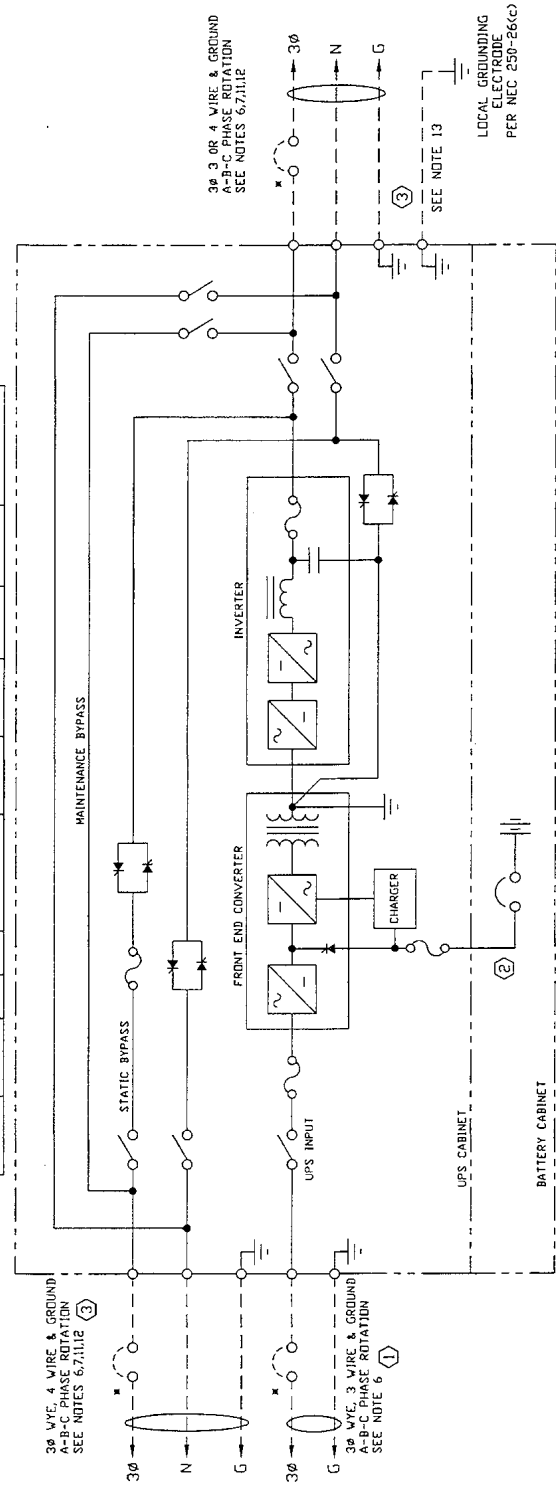

- NOTES:
- NOMINAL (NOM) CURRENT IS BASED ON FULL RATED OUTPUT LOAD.
 - MAXIMUM (MAX) CURRENT IS SHORT DURATION FOR BATTERY RECHARGE AND OVERLOAD CONDITIONS.
 - UPS INPUT AND OUTPUT CABLES MUST BE RUN IN SEPARATE CONDUITS.
 - NOMINAL BATTERY VOLTAGE IS SHOWN AT 2.0 VOLTS/CELL PER NEC 480-2.
 - RECOMMENDED AC OVERCURRENT PROTECTION REPRESENTS NONCONTINUOUS PLUS 125% OF NOMINAL FULL LOAD CURRENT (CONTINUOUS) PER NEC 220-3(G).
 - MINIMUM SIZED GROUNDING CONDUCTORS TO BE PER NEC 250-95. PARITY SIZED GROUND CONDUCTORS RECOMMENDED.
 - FOR 3 WIRE, 3 PHASE LOADS ONLY, AN INPUT NEUTRAL CONDUCTOR IS NOT REQUIRED. SEE NOTE 8. FOR LINE TO NEUTRAL LOADS, A NEUTRAL IS REQUIRED FROM THE INPUT SOURCE.
 - ALL WIRING IS TO BE IN ACCORDANCE WITH NATIONAL AND LOCAL ELECTRICAL CODES.
 - TOP OR BOTTOM CABLE ENTRY THROUGH REMOVABLE ACCESS PLATES. CUT PLATE TO SUIT CONDUIT SIZE THEN REPLACE.
 - CONTROL WIRING AND POWER WIRING MUST BE RUN IN SEPARATE CONDUITS.
 - NEC 310-16, NOTE 10(C) STATES THAT THE NEUTRAL CONDUCTOR IS TO BE CONSIDERED A CURRENT-CARRYING CONDUCTOR. FOLLOWING NEUTRAL WIRE IS REQUIRED, HOWEVER, FOR SOME NON-LINEAR LOADS, NEUTRAL CURRENT MAY EXCEED LINE CURRENT. FOR WIRE-SIZE CONDITIONS, THE WIRE SIZE FOR THE NEUTRAL CONDUCTOR SHOULD BE BASED ON THE MAXIMUM NEUTRAL CURRENT SHOWN IN TABLE 1 ABOVE. AMPACITIES OF CONDUCTORS SHOULD BE ADJUSTED PER NEC 310-16, NOTE 8, WHEN APPROPRIATE.
 - FOR A 3 PHASE, 4 WIRE OUTPUT, AN INPUT NEUTRAL CONDUCTOR IS REQUIRED. UPS SOURCES OTHER THAN STOCK BELTA BELTA TO VIVE ISOLATION TRANSFORMER MAY BE REQUIRED. CONDUCTOR SIZES REFER TO NEC ARTICLE 250 & LOCAL CODES FOR PROPER GROUNDING PRACTICES.
 - WITH THE NEUTRAL ISOLATION OPTION, THE UPS OUTPUT IS A SEPARATELY DERIVED SOURCE. PROVIDE GROUNDING ELECTRODE CONDUCTOR SIZED PER NEC TABLE 250-94.

TITLE	ONE-LINE DRAWING UPSTATION S3 12-24 KVA DUAL-INPUT CONFIGURATION WITH NEUTRAL ISOLATION 200-240V INPUT / OUTPUT
DRG. NO.	DATE
US312040	04-04-97
	

Figure 5 One Line Drawing - Single Input Configuration (400/480/600V In / 208V Out)

LEGEND
 --- FIELD SUPPLIED WIRING
 --- FACTORY SUPPLIED WIRING
 * EXTERNAL OVERCURRENT PROTECTION BY OTHERS

TABLE 1

POWER RATING KVA / KW	VOLTAGE VAC	① RECIFIER & BYPASS INPUT		② BATTERY		③ AC OUTPUT 208 VAC	
		NOM.	MAX.	NOMINAL VOLTAGE	MAX DISCHARGE CURRENT	NOMINAL CURRENT	MAXIMUM NEUTRAL CURRENT
12/8.4	400	15	21	240 VDC (120 CELLS)	51 A	33 A	57 A
	480	12	18	240 VDC (120 CELLS)	51 A	30 A	50 A
	600	10	14	240 VDC (120 CELLS)	51 A	20 A	50 A
16/11.2	400	20	28	240 VDC (120 CELLS)	68 A	40 A	60 A
	480	16	22	240 VDC (120 CELLS)	68 A	30 A	60 A
	600	13	19	240 VDC (120 CELLS)	68 A	30 A	60 A
20/14	400	25	35	240 VDC (120 CELLS)	85 A	50 A	80 A
	480	21	29	240 VDC (120 CELLS)	85 A	40 A	80 A
	600	16	23	240 VDC (120 CELLS)	85 A	30 A	80 A
24/16.8	400	28	42	240 VDC (120 CELLS)	102 A	60 A	115 A
	480	24	35	240 VDC (120 CELLS)	102 A	50 A	115 A
	600	20	28	240 VDC (120 CELLS)	102 A	40 A	115 A
NOTES		1	2	3,5,6,7,8,9,10	4	6,8,9,10	11

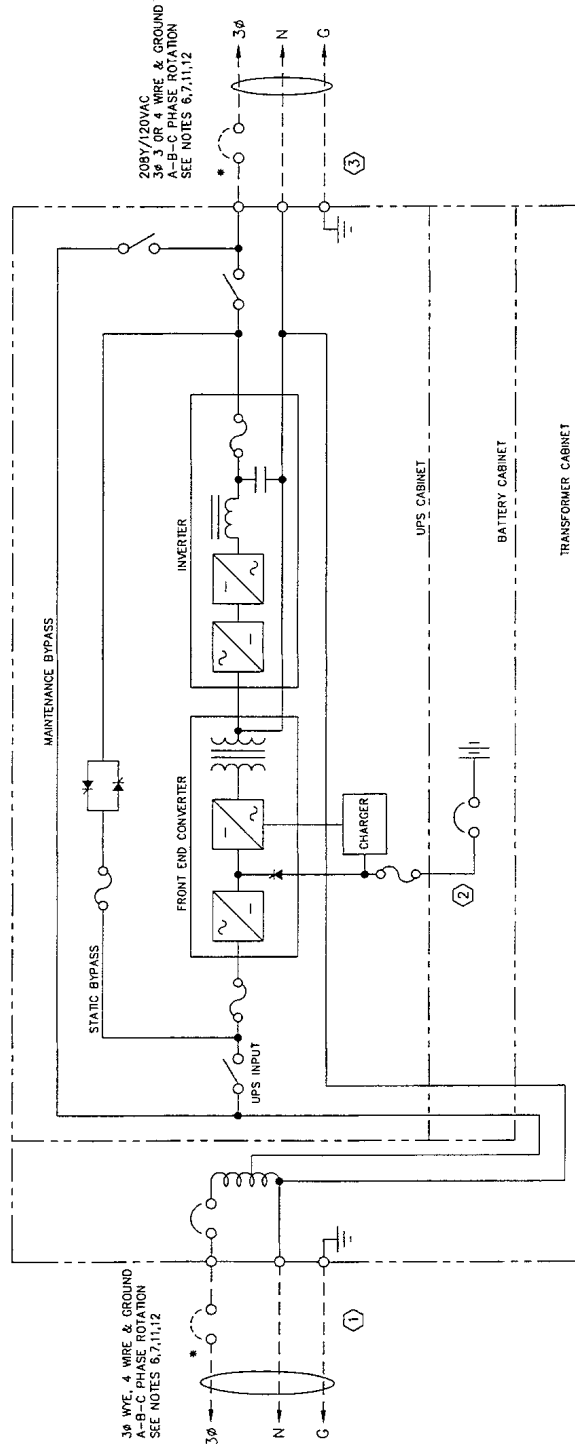

- NOTES:
- NOMINAL (NOM) CURRENT IS BASED ON FULL RATED OUTPUT LOAD.
 - MAXIMUM (MAX) CURRENT IS SHORT DURATION FOR BATTERY RECHARGE AND OVERLOAD CONDITIONS.
 - UPS INPUT AND OUTPUT CABLES MUST BE RUN IN SEPARATE CONDUITS.
 - NOMINAL BATTERY VOLTAGE IS SHOWN AT 2.0 VOLTS/CELL PER NEC 480-2.
 - RECOMMENDED AC OVERCURRENT PROTECTION REPRESENTS NONCONTINUOUS PLUS 125% OF NOMINAL FULL LOAD CURRENT (CONTINUOUS) PER NEC 220-3(g).
 - MINIMUM SIZED GROUNDING CONDUCTORS TO BE PER NEC 250-95. PARITY SIZED GROUND CONDUCTORS RECOMMENDED.
 - FOR 3 WIRE, 3 PHASE LOADS ONLY, AN INPUT NEUTRAL CONDUCTOR IS NOT REQUIRED; SEE NOTE 12. FOR LINE TO NEUTRAL LOADS, A NEUTRAL IS REQUIRED FROM THE INPUT SOURCE.
 - ALL WIRING IS TO BE IN ACCORDANCE WITH NATIONAL AND LOCAL ELECTRICAL CODES.
 - TOP OR BOTTOM CABLE ENTRY THROUGH BELIEVABLE ACCESS PLATES. CUT PLATE TO SUIT CONDUIT SIZE THEN REPLACE.
 - CONTROL WIRING AND POWER WIRING MUST BE RUN IN SEPARATE CONDUITS.
 - NEC 310-16, NOTE 10(C), STATES THAT THE NEUTRAL CONDUCTOR IS TO BE CONSIDERED A CURRENT-CARRYING CONDUCTOR. A FULLY-RATED NEUTRAL WIRE IS REQUIRED. HOWEVER, FOR SOME NON-LINEAR LOADS, NEUTRAL CURRENT MAY EXCEED LINE CURRENT. FOR WIRE SIZING BASED ON THE WIRE SIZE OF THE NEUTRAL CONDUCTOR, THE WIRE SIZE OF THE NEUTRAL CONDUCTOR SHOULD BE ADJUSTED PER NEC 310-16, NOTE 8, WHEN APPROPRIATE.
 - FOR A 3 PHASE, 3 WIRE (SOLIDLY GROUND WYE) INPUT SOURCE, THE UPS NEUTRAL OUTPUT MUST BE BONDED TO GROUND AND A LOCAL GROUNDING ELECTRODE CONDUCTOR MUST BE INSTALLED (NEC 250-26). FOR A 3 PHASE, 4 WIRE OUTPUT, AN INPUT NEUTRAL CONDUCTOR IS REQUIRED. FOR OTHER TYPES OF SOURCES, A DELTA TO WYE ISOLATION TRANSFORMER MAY BE REQUIRED. CONSULT WITH FACTORY. REFER TO NEC ARTICLE 250 & LOCAL CODES FOR PROPER GROUNDING PRACTICES.

TITLE	ONE-LINE DRAWING UPSTATION S3 12-24 KVA SINGLE-INPUT CONFIGURATION WITH INPUT AUTOTRANSFORMER 400/480/600V INPUT, 208V OUTPUT
DRG. NO.	DATE
US312012	04-04-97
CONFIG.	
<small>1995 DURELON, INC. P.O. BOX 20186, COLUMBUS, OH 43228</small>	

Figure 6 One Line Drawing - Dual Input Configuration (400/480/600V In / 208V Out)

TABLE 1

POWER RATING KVA / KW	VOLTAGE VAC	① AC RECTIFIER INPUT		② BATTERY		③ BYPASS INPUT 208 VAC		④ AC OUTPUT 208 VAC			
		CURRENT NOM.	MAX.	NOMINAL VOLTAGE	MAX. DISCHARGE CURRENT	NOMINAL CURRENT	MAXIMUM NEUTRAL CURRENT	RECOMMENDED EXTERNAL OVERCURRENT PROTECTION	NOMINAL CURRENT	MAXIMUM NEUTRAL CURRENT	RECOMMENDED EXTERNAL OVERCURRENT PROTECTION
12/8.4	400	15	19	240 VDC (120 CELLS)	51 A	33 A	57 A	33 A	57 A	50 A	
	480	12	15								
	600	10	12								
16/11.2	400	20	25	240 VDC (120 CELLS)	67 A	44 A	76 A	44 A	76 A	60 A	
	480	16	21								
	600	13	16								
20/14	400	25	31	240 VDC (120 CELLS)	84 A	56 A	97 A	56 A	97 A	80 A	
	480	19	24								
	600	16	21								
24/16.8	400	29	37	240 VDC (120 CELLS)	101 A	67 A	115 A	67 A	115 A	100 A	
	480	24	31								
	600	20	24								
NOTES		1	2	4	6,8,9,10	1	11	3,5,6,7,8,9,10	1	11	3,5,6,7,8,9,10

LEGEND
 --- FIELD SUPPLIED WIRING
 --- FACTORY SUPPLIED WIRING
 * EXTERNAL OVERCURRENT PROTECTION BY OTHERS

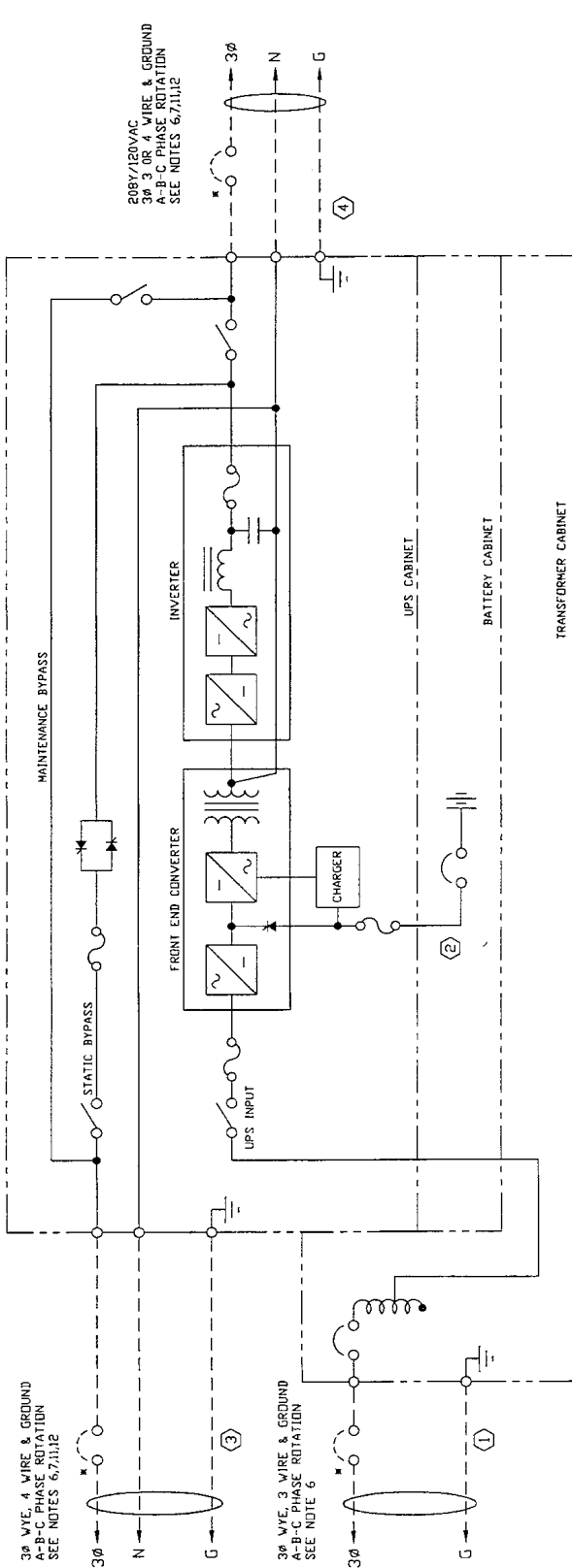

3 ϕ WYE, 4 WIRE & GROUND
A-B-C PHASE ROTATION
SEE NOTES 6,7,11,12

3 ϕ WYE, 3 WIRE & GROUND
A-B-C PHASE ROTATION
SEE NOTE 6

208Y/120VAC WIRE & GROUND
A-B-C PHASE ROTATION
SEE NOTES 6,7,11,12

- NOTES:**
1. NOMINAL (NOM) CURRENT IS BASED ON FULL RATED OUTPUT LOAD.
 2. MAXIMUM (MAX) CURRENT IS SHORT DURATION FOR BATTERY RECHARGE AND OVERLOAD CONDITIONS.
 3. UPS INPUT AND OUTPUT CABLES MUST BE RUN IN SEPARATE CONDUITS.
 4. NOMINAL BATTERY VOLTAGE IS SHOWN AT 2.0 VOLTS/CELL PER NEC 480-2.
 5. RECOMMENDED AC OVERCURRENT PROTECTION REPRESENTS NONCONTINUOUS PLUS 125% OF NOMINAL FULL LOAD CURRENT (CONTINUOUS) PER NEC 220-3(a).
 6. MINIMUM SIZED GROUNDING CONDUCTORS TO BE PER NEC 250-95. PARITY SIZED GROUND CONDUCTORS RECOMMENDED.
 7. FOR 3 WIRE, 3 PHASE LOADS ONLY, AN INPUT NEUTRAL CONDUCTOR IS NOT REQUIRED. SEE NOTE 12. FOR LINE TO NEUTRAL LOADS, A NEUTRAL IS REQUIRED FROM THE INPUT SOURCE.
 8. ALL WIRING IS TO BE IN ACCORDANCE WITH NATIONAL AND LOCAL ELECTRICAL CODES. TOP OR BOTTOM CABLE ENTRY THROUGH REMOVABLE ACCESS PLATES. CUT PLATE TO SUIT CONDUIT SIZE THEN REPLACE.
 9. TOP OR BOTTOM CABLE ENTRY THROUGH REMOVABLE ACCESS PLATES. CUT PLATE TO SUIT CONDUIT SIZE THEN REPLACE.
 10. CONTROL WIRING AND POWER WIRING MUST BE RUN IN SEPARATE CONDUITS.
 11. NEC 310-16, NOTE 10(C), STATES THAT THE NEUTRAL CONDUCTOR IS TO BE CONSIDERED A CURRENT CARRYING CONDUCTOR. A FULL-RATED NEUTRAL CONDUCTOR MUST BE PROVIDED FOR THE UPS. THE NEUTRAL CONDUCTOR CURRENT MAY EXCEED THE CURRENT FOR WIRETYPE CASE CONDITIONS. THE WIRE SIZE FOR THE NEUTRAL CONDUCTOR SHOULD BE BASED ON THE MAXIMUM NEUTRAL CURRENT SHOWN IN TABLE 1 ABOVE. AMPACITIES OF CONDUCTORS SHOULD BE ADJUSTED PER NEC 310-16, NOTE 8, WHEN APPROPRIATE.
 12. FOR A 3 PHASE, 3 WIRE (SOLIDLY GROUND WYE) INPUT SOURCE, THE UPS NEUTRAL OUTPUT MUST BE BONDED TO GROUND AND A LOCAL GROUNDING ELECTRODE CONDUCTOR MUST BE INSTALLED (NEC 250-26). FOR A 3 PHASE, 4 WIRE OUTPUT, AN INPUT NEUTRAL CONDUCTOR IS REQUIRED. THE NEUTRAL CONDUCTOR MUST BE INSTALLED IN ACCORDANCE WITH FACTORY WIRING PRACTICES. REFER TO ARTICLE 250 & LOCAL CODES FOR PROPER GROUNDING PRACTICES.

TITLE		ONE-LINE DRAWING	
UPSTATION S3 12-24 KVA		DUAL-INPUT CONFIGURATION	
WITH INPUT AUTOTRANSFORMER		400/480/600V INPUT AND 208V BYPASS	
DRG. NO.	DATE	CONFIG.	
US312022	04-04-97		

100% SCRAMBLER SERVICE, INC. 301 4784, COLLETTA, OHIO 43029

Figure 7 One Line Drawing - Single Input Configuration With Neutral Isolation (400/480/600V In / 208V Out)

LEGEND
 --- FIELD SUPPLIED WIRING
 - - - FACTORY SUPPLIED WIRING
 * EXTERNAL OVERCURRENT PROTECTION BY OTHERS

TABLE 1

POWER RATING KVA / KW	VOLTAGE VAC	① RECTIFIER & BYPASS INPUT		② BATTERY		③ AC OUTPUT 208 VAC		
		CURRENT (AMPS) NOM. BYP. MAX.	RECOMMENDED EXTERNAL OVERCURRENT PROTECTION	NOMINAL VOLTAGE	MAX DISCHARGE CURRENT	NOMINAL CURRENT	MAXIMUM NEUTRAL CURRENT	RECOMMENDED EXTERNAL OVERCURRENT PROTECTION
12/8.4	400	15	17	21	30 A	33 A	57 A	50 A
	480	12	14	18	20 A			
	600	10	12	14				
16/11.2	400	20	23	28	40 A	44 A	76 A	60 A
	480	16	19	23	30 A			
	600	13	15	19				
20/14	400	25	29	35	50 A	56 A	97 A	80 A
	480	21	24	29	40 A			
	600	18	21	23	30 A			
24/16.8	400	29	35	42	60 A	67 A	115 A	100 A
	480	24	29	35	50 A			
	600	20	23	28	40 A			
NOTES		1	2	3,5,6,7,8,9,10	4	6,8,9,10	1	11

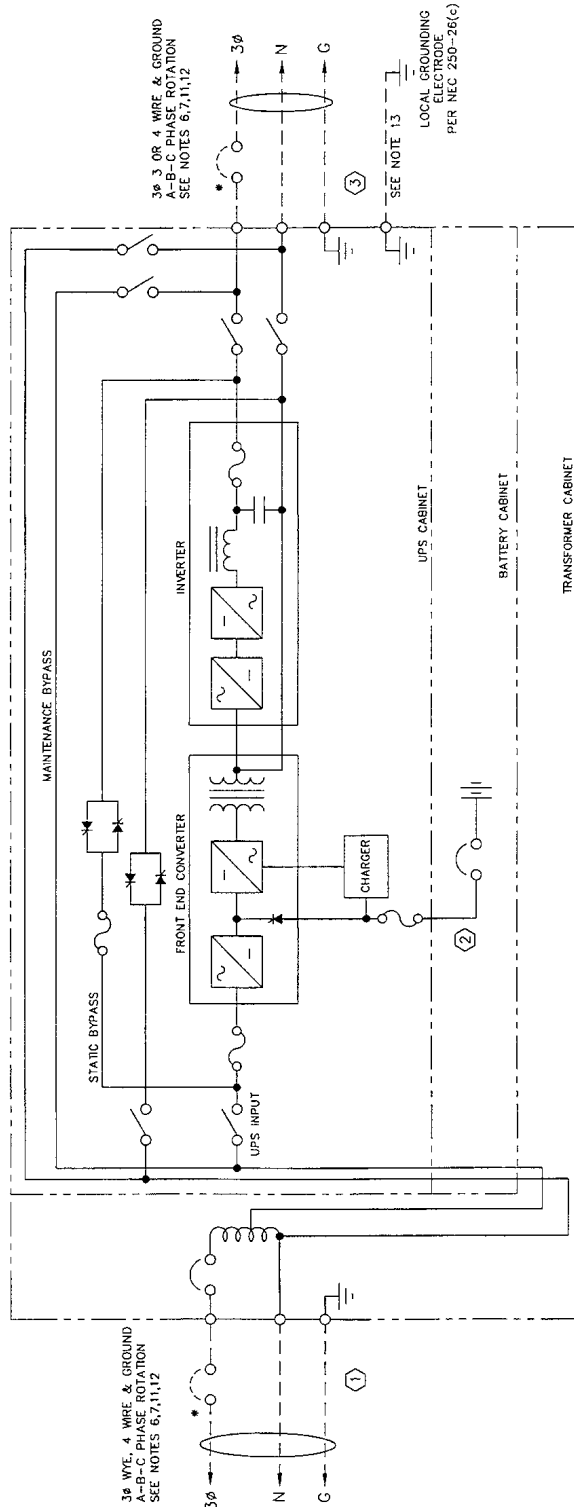

TITLE	ONE-LINE DRAWING UPSTATION S3 12-24 KVA SINGLE-INPUT CONFIGURATION ISOLATED NEUTRAL WITH INPUT AUTOTRANSFORMER 400/480/600V INPUT, 208V OUTPUT
DWG. NO.	DATE
US312032	05-30-97
Liabert 100 EASTMAN DRIVE, P.O. BOX 3180, COVINGTON, LOUISIANA 70032	

- NOTES:**
- NOMINAL (NOM) CURRENT IS BASED ON FULL RATED OUTPUT LOAD.
 - MAXIMUM (MAX) CURRENT IS SHORT DURATION FOR BATTERY RECHARGE AND OVERLOAD CONDITIONS.
 - UPS INPUT AND OUTPUT CABLES MUST BE RUN IN SEPARATE CONDUITS.
 - NOMINAL BATTERY VOLTAGE IS SHOWN AT 2.0 VOLTS/CELL PER NEC 480-2.
 - RECOMMENDED AC OVERCURRENT PROTECTION REPRESENTS NONCONTINUOUS PLUS 125% OF NOMINAL FULL LOAD CURRENT (CONTINUOUS) PER NEC 220-3(G).
 - MINIMUM SIZED GROUNDING CONDUCTORS TO BE PER NEC 250-95. PARITY SIZED GROUND CONDUCTORS RECOMMENDED.
 - FOR 3 WIRE, 3 PHASE LOADS ONLY, AN INPUT NEUTRAL CONDUCTOR IS NOT REQUIRED. SEE NOTE 12. FOR LINE TO NEUTRAL LOADS, A NEUTRAL IS REQUIRED FROM THE INPUT SOURCE.
 - ALL WIRING IS TO BE IN ACCORDANCE WITH NATIONAL AND LOCAL ELECTRICAL CODES.
 - TOP OR BOTTOM CABLE ENTRY THROUGH REMOVABLE ACCESS PLATES, CUT PLATE TO SUIT CONDUIT SIZE THEN REPLACE.
 - CONTROL WIRING AND POWER WIRING MUST BE RUN IN SEPARATE CONDUITS.
 - NEC 310-16, NOTE 10(G), STATES THAT THE NEUTRAL CONDUCTOR IS TO BE CONSIDERED A CURRENT-CARRYING CONDUCTOR. A FULLY-RATED NEUTRAL WIRE IS REQUIRED. HOWEVER, FOR SOME NON-LINEAR LOADS, NEUTRAL CURRENT MAY EXCEED LINE CURRENT. FOR WORST-CASE CONDITIONS, THE WIRE SIZE NEUTRAL CURRENT SHALL BE BASED ON THE MAXIMUM NEUTRAL CURRENT SHOWN IN TABLE ABOVE. ALL TYPES OF CONDUCTORS SHOULD BE ADJUSTED PER NEC 310-16, NOTE 8, WHEN APPROPRIATE.
 - FOR A 3 PHASE, 3 WIRE (SOLIDLY GROUND WYE) INPUT SOURCE, THE UPS NEUTRAL OUTPUT MUST BE BONDED TO GROUND AND A LOCAL GROUNDING ELECTRODE CONDUCTOR MUST BE INSTALLED (NEC 250-28).
 - FOR A 3 PHASE, 4 WIRE OUTPUT, AN INPUT NEUTRAL CONDUCTOR IS REQUIRED. FOR OTHER TYPES OF SOURCES, A DELTA TO WYE ISOLATION TRANSFORMER MAY BE REQUIRED. CONSULT WITH FACTORY. REFER TO NEC ARTICLE 250 & LOCAL CODES FOR PROPER GROUNDING PRACTICES.
 - WITH THE NEUTRAL ISOLATION OPTION, THE UPS OUTPUT IS A SEPARATELY DERIVED SOURCE. PROVIDE GROUNDING ELECTRODE CONDUCTOR SIZED PER NEC TABLE 250-94.

Figure 8 One Line Drawing - Dual Input Configuration With Neutral Isolation (400/480/600V In / 208V Out)

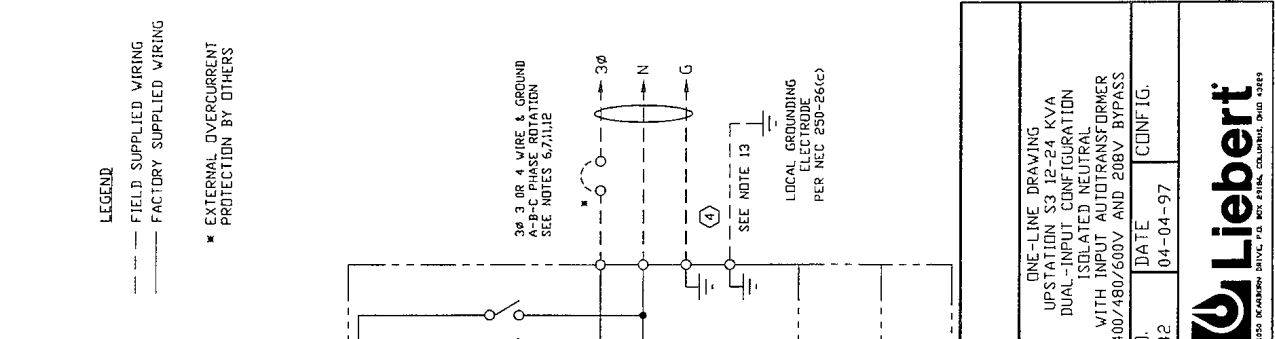

TABLE 1

POWER RATING KVA / KW	VOLTAGE VAC	① AC RECTIFIER INPUT		② BATTERY		③ BYPASS INPUT 208 VAC		④ AC OUTPUT 208 VAC			
		CURRENT NOM.	MAX. CURRENT	NOMINAL VOLTAGE	MAX DISCHARGE CURRENT	NOMINAL CURRENT	MAXIMUM NEUTRAL CURRENT	RECOMMENDED EXTERNAL OVERCURRENT PROTECTION	NOMINAL CURRENT	MAXIMUM NEUTRAL CURRENT	
12/8.4	400 480 600	15 12 10	19 15 12	240 VDC (120 CELLS)	51 A	33 A	57 A	50 A	33 A	57 A	50 A
16/11.2	400 480 600	20 13	25 16	240 VDC (120 CELLS)	67 A	44 A	76 A	80 A	44 A	76 A	80 A
20/14	400 480 600	25 18	31 21	240 VDC (120 CELLS)	84 A	56 A	97 A	80 A	56 A	97 A	80 A
24/16.8	400 480 600	29 20	37 24	240 VDC (120 CELLS)	101 A	67 A	115 A	100 A	67 A	115 A	100 A
NOTES		1	2	3,5,6,7,8,9,10	4	6,8,9,10	1	11	3,5,6,7,8,9,10	1	11

① 3 ϕ WYE, 4 WIRE & GROUND
A-B-C PHASE ROTATION
SEE NOTES 6,7,11,12

② 3 ϕ WYE, 3 WIRE & GROUND
A-B-C PHASE ROTATION
SEE NOTE 6

LEGEND
- - - - - FIELD SUPPLIED WIRING
- - - - - FACTORY SUPPLIED WIRING
* EXTERNAL OVERCURRENT PROTECTION BY OTHERS

③ 3 ϕ OR 4 WIRE & GROUND
A-B-C PHASE ROTATION
SEE NOTES 6,7,11,12

④ LOCAL GROUNDING ELECTRODE PER NEC 250-26(C)

① ONE-LINE DRAWING
UPSTATION S3 12-24 KVA
DUAL-INPUT CONFIGURATION
ISOLATED NEUTRAL
WITH INPUT AUTO TRANSFORMER
400/480/600V AND 208V BYPASS

DRG. NO. US312042
DATE 04-04-97
CONF. IG.

Liabert
1000 KILBOURN BLVD., P.O. BOX 218K, COVINGTON, LA 70032

- NOTES:**
- NOMINAL (NOM) CURRENT IS BASED ON FULL RATED OUTPUT LOAD.
 - MAXIMUM (MAX) CURRENT IS SHORT DURATION FOR BATTERY RECHARGE AND OVERLOAD CONDITIONS.
 - UPS INPUT AND OUTPUT CABLES MUST BE RUN IN SEPARATE CONDUITS.
 - NOMINAL BATTERY VOLTAGE IS SHOWN AT 2.0 VOLTS/CELL PER NEC 480-2.
 - RECOMMENDED AC OVERCURRENT PROTECTION REPRESENTS NONCONTINUOUS PLUS 125% OF NOMINAL FULL LOAD CURRENT (CONTINUOUS) PER NEC 220-3(a).
 - MINIMUM SIZED GROUNDING CONDUCTORS TO BE PER NEC 250-95. PARITY SIZED GROUND CONDUCTORS RECOMMENDED.
 - FOR 3 WIRE, 3 PHASE LOADS ONLY, AN INPUT NEUTRAL CONDUCTOR IS NOT REQUIRED. SEE NOTE 12. FOR LINE TO NEUTRAL LOADS, A NEUTRAL IS REQUIRED FROM THE INPUT SOURCE.
 - ALL WIRING IS TO BE IN ACCORDANCE WITH NATIONAL AND LOCAL ELECTRICAL CODES.
 - TOP OR BOTTOM CABLE ENTRY THROUGH REMOVABLE ACCESS PLATES. CUT PLATE TO SUIT CONDUIT SIZE THEN REPLACE.
 - CONTROL WIRING AND POWER WIRING MUST BE RUN IN SEPARATE CONDUITS.
 - NEC 310-16, NOTE 10(C) STATES THAT THE NEUTRAL CONDUCTOR IS TO BE CONSIDERED A CURRENT-CARRYING CONDUCTOR. A FULLY-RATED NEUTRAL WIRE IS REQUIRED. HOWEVER, FOR SOME NON-LINEAR LOADS, NEUTRAL CURRENT MAY EXCEED LINE CURRENT. FOR WORST-CASE CONDITIONS, THE WIRE SIZE FOR THE NEUTRAL CONDUCTOR SHOULD BE BASED ON THE MAXIMUM NEUTRAL CURRENT SHOWN IN TABLE 1 ABOVE. CAPACITIES OF CONDUCTORS SHOULD BE ADJUSTED PER NEC 310-16, NOTE 8, WHEN APPROPRIATE.
 - FOR A 3 PHASE, 4 WIRE OUTPUT, AN INPUT NEUTRAL CONDUCTOR IS REQUIRED. FOR SOURCES OTHER THAN A SOLIDLY GROUNDED WYE, A DELTA TO WYE ISOLATION TRANSFORMER MAY BE REQUIRED. CONSULT WITH FACTORY. REFER TO NEC ARTICLE 250 & LOCAL CODES FOR PROPER GROUNDING PRACTICES.
 - WITH THE NEUTRAL ISOLATION OPTION, THE UPS OUTPUT IS A SEPARATELY DERIVED SOURCE. PROVIDE GROUNDING ELECTRODE CONDUCTOR SIZED PER NEC TABLE 250-94.

Figure 9 One Line Drawing - Single Input Configuration (400/480/600V In/Out)

TABLE 1

POWER RATING KVA / KW	VOLTAGE VAC	① RECTIFIER & BYPASS INPUT			② BATTERY		③ OUTPUT		
		CURRENT (AMPS) NOM. BYP. MAX.	RECOMMENDED OVERCURRENT PROTECTION	NOMINAL VOLTAGE	MAX DISCHARGE CURRENT	NOMINAL CURRENT	MAXIMUM NEUTRAL CURRENT	RECOMMENDED EXTERNAL OVERCURRENT PROTECTION	
12/8.4	400	15	17	21	240 VDC (120 CELLS)	17 A	28 A	30 A	
	480	12	14	18		14 A	24 A	20 A	
	600	10	12	14		12 A	21 A	15 A	
16/11.2	400	20	23	28	240 VDC (120 CELLS)	23 A	40 A	30 A	
	480	15	18	22		19 A	33 A	30 A	
	600	13	15	19		15 A	20 A	20 A	
20/14	400	25	29	35	240 VDC (120 CELLS)	28 A	50 A	40 A	
	480	21	24	29		24 A	42 A	30 A	
	600	16	19	23		19 A	33 A	30 A	
24/16.8	400	29	35	42	240 VDC (120 CELLS)	35 A	61 A	50 A	
	480	21	26	32		41 A	40 A	30 A	
	600	20	23	28		23 A	40 A	30 A	
NOTES		1	1	2	4	6,8,9,10	1	11	3,5,6,7,8,9,10

LEGEND
 --- FIELD SUPPLIED WIRING
 - - - FACTORY SUPPLIED WIRING
 * EXTERNAL OVERCURRENT PROTECTION BY OTHERS

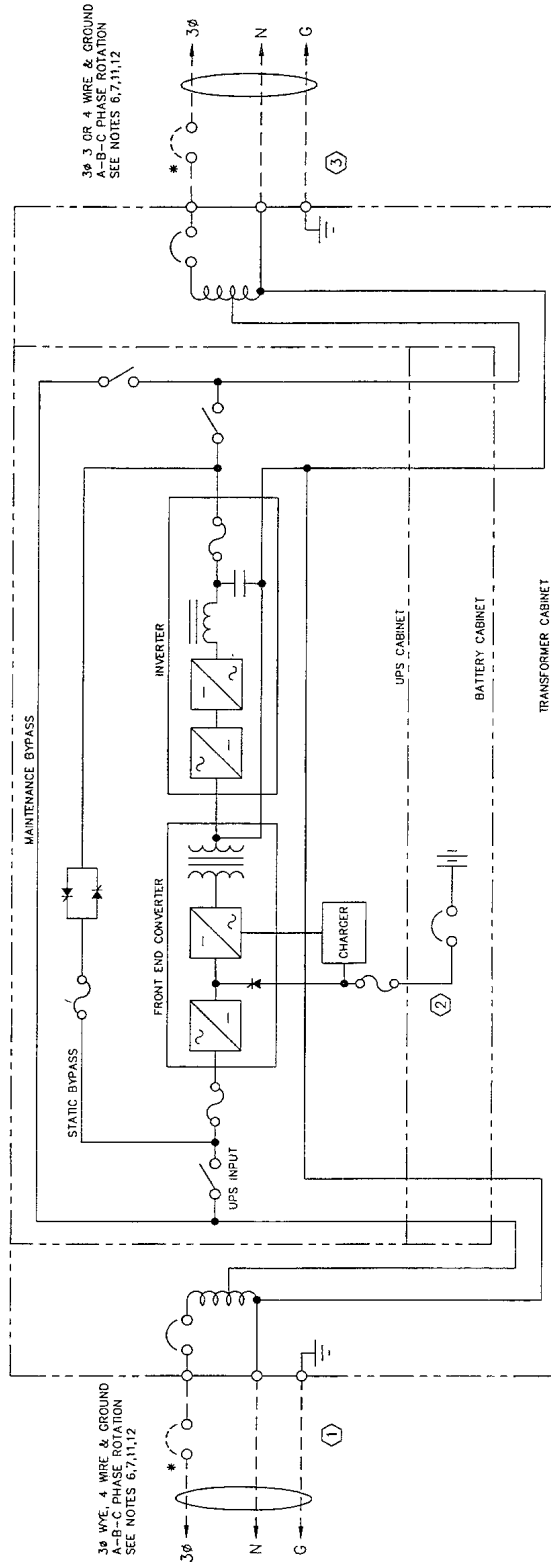

- NOTES:
- NOMINAL (NOM) CURRENT IS BASED ON FULL RATED OUTPUT LOAD.
 - MAXIMUM (MAX) CURRENT IS SHORT DURATION FOR BATTERY RECHARGE AND OVERLOAD CONDITIONS.
 - UPS INPUT AND OUTPUT CABLES MUST BE RUN IN SEPARATE CONDUITS.
 - NOMINAL BATTERY VOLTAGE IS SHOWN AT 2.0 VOLTS/CELL PER NEC 480-2.
 - RECOMMENDED AC OVERCURRENT PROTECTION REPRESENTS NONCONTINUOUS PLUS 125% OF NOMINAL FULL LOAD CURRENT (CONTINUOUS) PER NEC 220-3(g).
 - MINIMUM SIZED GROUNDING CONDUCTORS TO BE PER NEC 250-95. PARITY SIZED GROUNDING CONDUCTORS RECOMMENDED.
 - FOR 3 WIRE, 3 PHASE LOADS ONLY, AN INPUT NEUTRAL CONDUCTOR IS NOT REQUIRED. SEE NOTE 12. FOR LINE TO NEUTRAL LOADS, A NEUTRAL IS REQUIRED FROM THE INPUT SOURCE.
 - ALL WIRING IS TO BE IN ACCORDANCE WITH NATIONAL AND LOCAL ELECTRICAL CODES.
 - TOP OR BOTTOM CABLE ENTRY THROUGH REMOVABLE ACCESS PLATES. CUT PLATE TO SUIT CONDUIT SIZE THEN REPLACE.
 - CONTROL WIRING AND POWER WIRING MUST BE RUN IN SEPARATE CONDUITS.
 - NEC 310-16, NOTE 10(G), STATES THAT THE NEUTRAL CONDUCTOR IS TO BE CONSIDERED A CURRENT-CARRYING CONDUCTOR. A FULLY-RATED NEUTRAL WIRE IS REQUIRED. HOWEVER, FOR SOME NON-LINEAR LOADS, NEUTRAL CURRENT MAY EXCEED LINE CURRENT. FOR WORST-CASE CONDITIONS, THE WIRE SIZE FOR THE NEUTRAL CONDUCTOR SHOULD BE BASED ON THE MAXIMUM NEUTRAL CURRENT SHOWN IN TABLE 1 ABOVE. AMPACITIES OF CONDUCTORS SHOULD BE ADJUSTED PER NEC 310-16, NOTE 8, WHEN APPROPRIATE.
 - FOR A 3 PHASE, 3 WIRE (SOLIDLY GROUND WYE) INPUT SOURCE, THE UPS INPUT OUTPUT MUST BE BONDING TO GROUND AND A LOCAL GROUNDING ELECTRODE SYSTEM MUST BE INSTALLED. FOR 208Y/120V, 208Y/120/208V, 480Y/277V, 480Y/277/480V, 600Y/346V, 600Y/346/600V, A DELTA TO WYE ISOLATION TRANSFORMER MAY BE REQUIRED. CONSULT WITH FACTORY REFER TO NEC ARTICLE 250 & LOCAL CODES FOR PROPER GROUNDING PRACTICES.

TITLE	ONE-LINE DRAWING UPSTATION S3 12-24 KVA SINGLE-INPUT CONFIGURATION WITH INPUT AND OUTPUT AUTOTRANSFORMERS 400/480/600V, INPUT / OUTPUT
DRG. NO.	DATE
US312011	04-04-97

Figure 10 One Line Drawing - Dual Input Configuration (400/480/600V In/Out)

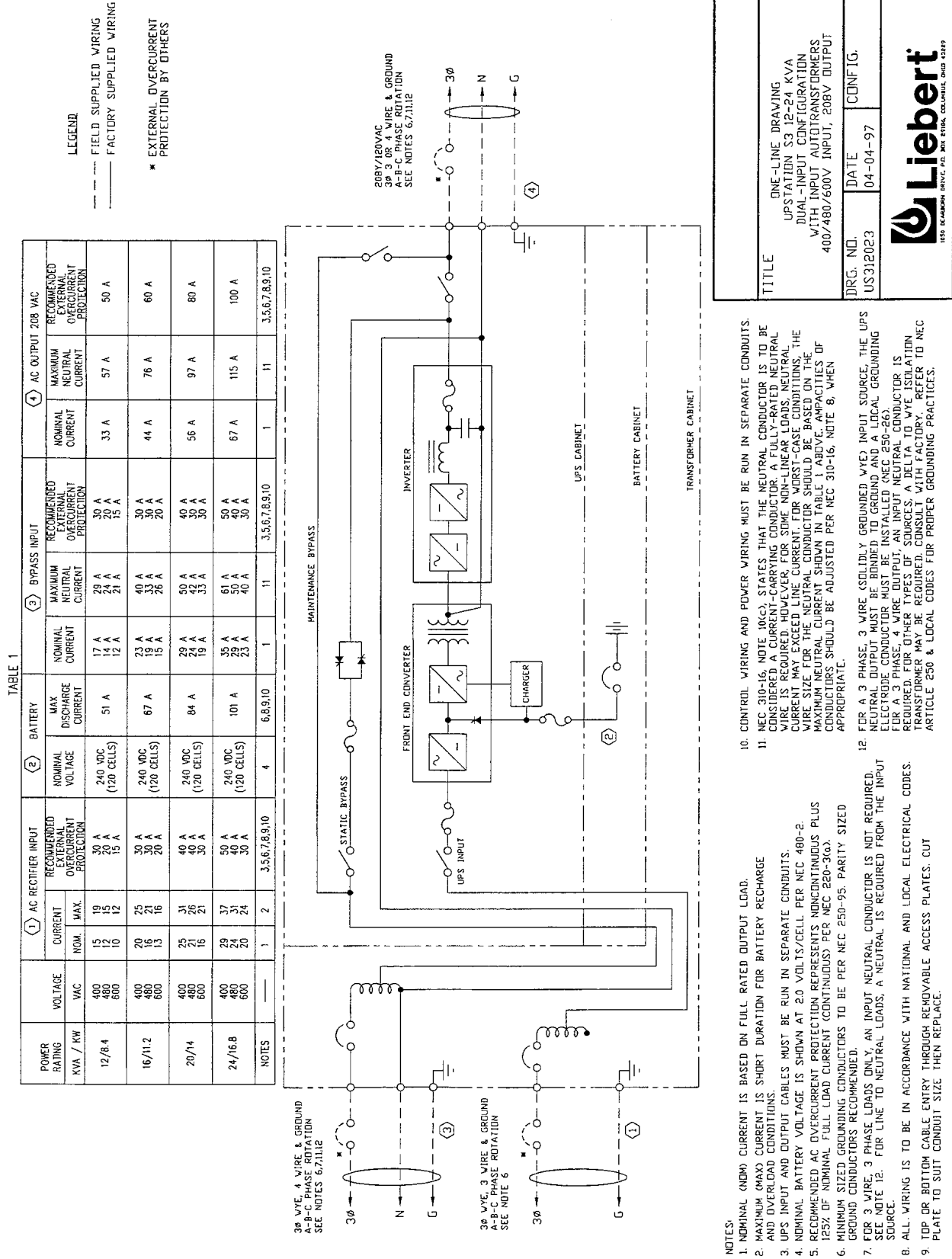

Figure 11 One Line Drawing - Single Input Configuration With Neutral Isolation (400/480/600V In/Out)

LEGEND

- FIELD SUPPLIED WIRING
- FACTORY SUPPLIED WIRING
- * EXTERNAL OVERCURRENT PROTECTION BY OTHERS

TABLE 1

POWER RATING KVA / KW	VOLTAGE VAC	① RECTIFIER & BYPASS INPUT		② BATTERY		③ OUTPUT		
		CURRENT (AMPS) NOM. BYP. MAX.	RECOMMENDED EXTERNAL OVERCURRENT PROTECTION	NOMINAL VOLTAGE	MAY DISCHARGE CURRENT	NOMINAL CURRENT	MAXIMUM NEUTRAL CURRENT	RECOMMENDED EXTERNAL OVERCURRENT PROTECTION
12/8.4	480	15	17	21	30 A	17 A	29 A	30 A
	480	16	18	22	20 A	12 A	21 A	15 A
	600	16	18	22	20 A	12 A	21 A	15 A
16/11.2	400	20	23	28	40 A	23 A	40 A	30 A
	480	16	19	23	30 A	19 A	33 A	30 A
	600	13	15	19	20 A	14 A	28 A	20 A
20/14	400	25	29	35	50 A	29 A	50 A	40 A
	480	21	24	29	40 A	24 A	42 A	30 A
	600	16	19	23	30 A	19 A	33 A	30 A
24/16.8	400	29	35	42	60 A	35 A	61 A	50 A
	480	24	29	35	50 A	29 A	50 A	40 A
	600	20	23	28	40 A	23 A	40 A	30 A
NOTES		1	2	3,5,6,7,8,9,10	4	6,8,9,10	11	3,5,6,7,8,9,10

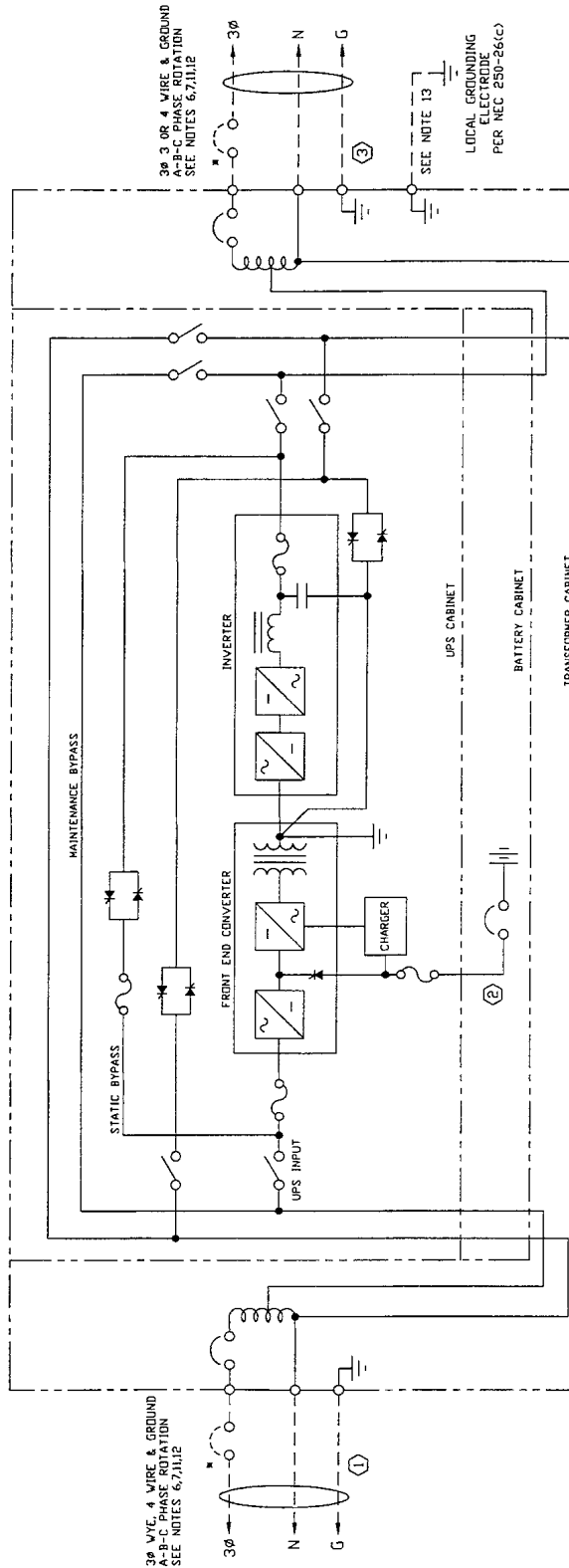

TITLE ONE-LINE DRAWING
UPSTATION S3 12-24 KVA
SINGLE-INPUT CONFIGURATION
ISOLATED NEUTRAL
WITH INPUT AND OUTPUT AUTOTRANSFORMERS
400/480/600V INPUT / OUTPUT

DRG. NO. US312031

DATE 04-04-97

CUNFIG.

Liabert
100 MARLBOROUGH DRIVE, P.O. BOX 29166, COLUMBUS, OHIO 43229

- NOTES:
1. NOMINAL (NOM) CURRENT IS BASED ON FULL RATED OUTPUT LOAD.
 2. MAXIMUM (MAX) CURRENT IS SHORT DURATION FOR BATTERY RECHARGE AND OVERLOAD CONDITIONS.
 3. UPS INPUT AND OUTPUT CABLES MUST BE RUN IN SEPARATE CONDUITS.
 4. NOMINAL BATTERY VOLTAGE IS SHOWN AT 2.0 VOLTS/CELL PER NEC 480-2.
 5. RECOMMENDED AC OVERCURRENT PROTECTION REPRESENTS NONCONTINUOUS PLUS 125% OF NOMINAL FULL LOAD CURRENT (CONTINUOUS) PER NEC 220-3(a).
 6. MINIMUM SIZED GROUNDING CONDUCTORS TO BE PER NEC 250-95. PARITY SIZED GROUND CONDUCTORS RECOMMENDED.
 7. FOR 3 WIRE, 3 PHASE LOADS ONLY, AN INPUT NEUTRAL CONDUCTOR IS NOT REQUIRED. SEE NOTE 1E. FOR LINE TO NEUTRAL LOADS, A NEUTRAL IS REQUIRED FROM THE INPUT SOURCE.
 8. ALL WIRING IS TO BE IN ACCORDANCE WITH NATIONAL AND LOCAL ELECTRICAL CODES.
 9. TOP OR BOTTOM CABLE ENTRY THROUGH REMOVABLE ACCESS PLATES. CUT PLATE TO SUIT CONDUIT SIZE THEN REPLACE.
 10. CONTROL WIRING AND POWER WIRING MUST BE RUN IN SEPARATE CONDUITS.
 11. NEC 310-16, NOTE 10(c), STATES THAT THE NEUTRAL CONDUCTOR IS TO BE CONSIDERED A CURRENT-CARRYING CONDUCTOR. A FULLY-RATED NEUTRAL WIRE IS REQUIRED. HOWEVER, FOR SOME NON-LINEAR LOADS, NEUTRAL CURRENT MAY EXCEED LINE CURRENT. FOR WORST-CASE CONDITIONS, THE WIRE SIZE FOR THE NEUTRAL CONDUCTOR SHOULD BE BASED ON THE MAXIMUM NEUTRAL CURRENT SHOWN IN TABLE 1 ABOVE. AMPACITIES OF CABLES SHOULD BE ADJUSTED PER NEC 310-16, NOTE 8, WHEN APPROPRIATE.
 12. FOR A 3 PHASE, 4 WIRE OUTPUT, AN INPUT NEUTRAL CONDUCTOR IS REQUIRED. FOR SOURCES OTHER THAN A SOLIDLY GROUNDED WYE, A DELTA TO WYE ISOLATION TRANSFORMER MAY BE REQUIRED. CONSULT WITH FACTORY. REFER TO NEC ARTICLE 250 & LOCAL CODES FOR PROPER GROUNDING PRACTICES.
 13. WITH THE NEUTRAL ISOLATION OPTION, THE UPS OUTPUT IS A SEPARATELY DERIVED SOURCE. PROVIDE GROUNDING ELECTRODE CONDUCTOR SIZED PER NEC TABLE 250-94.

Figure 12 One Line Drawing - Dual Input Configuration With Neutral Isolation (400/480/600V In/Out)

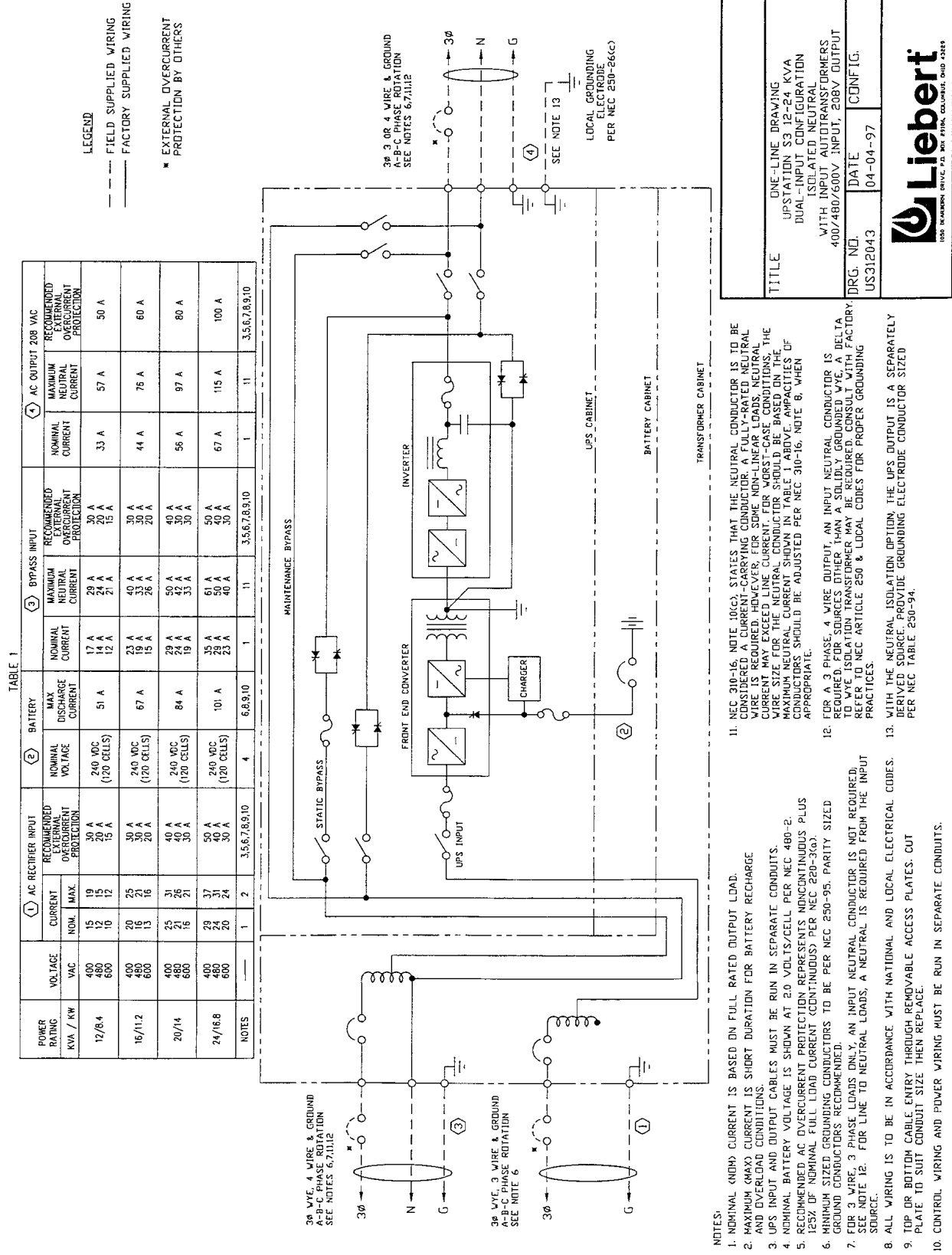

TABLE 1

POWER RATING KVA / KW	AC RECIPHER INPUT		BATTERY		BYPASS INPUT		AC OUTPUT 208 VAC	
	VOLTAGE VAC	CURRENT NOM. MAX.	NOMINAL VOLTAGE	MAX DISCHARGE CURRENT	NOMINAL CURRENT	MAXIMUM CURRENT	NOMINAL CURRENT	RECOMMENDED EXTERNAL OVERCURRENT PROTECTION
12/8.4	400 480 600	15 12 10	240 VDC (120 CELLS)	51 A	17 A 14 A 12 A	20 A 24 A 21 A	30 A 20 A 15 A	50 A
16/11.2	400 480 600	20 15 13	240 VDC (120 CELLS)	67 A	23 A 19 A 15 A	40 A 26 A 20 A	30 A 20 A 15 A	60 A
20/14	400 480 600	25 18 16	240 VDC (120 CELLS)	84 A	29 A 24 A 19 A	50 A 37 A 30 A	40 A 30 A 20 A	80 A
24/16.8	400 480 600	29 24 20	240 VDC (120 CELLS)	101 A	35 A 29 A 23 A	61 A 50 A 40 A	50 A 40 A 30 A	100 A
NOTES		1 2	4	6,8,9,10	1 11	3,5,6,7,8,9,10	1 11	3,5,6,7,8,9,10

TITLE
 ONE-LINE DRAWING
 UPSTATION S3 12-24 KVA
 DUAL-INPUT CONFIGURATION
 ISOLATED NEUTRAL
 WITH INPUT AUTO TRANSFORMERS
 400/480/600V INPUT, 208V OUTPUT

DRG. NO. US312043
DATE 04-04-97
CONF. TO

1000 INDIAN RIVER, P.O. BOX 5718, COLUMBUS, OHIO 43269

- NOTES:
1. NOMINAL (NOM) CURRENT IS BASED ON FULL RATED OUTPUT LOAD.
 2. MAXIMUM (MAX) CURRENT IS SHORT DURATION FOR BATTERY RECHARGE AND OVERLOAD CONDITIONS.
 3. UPS INPUT AND OUTPUT CABLES MUST BE RUN IN SEPARATE CONDUITS.
 4. NOMINAL BATTERY VOLTAGE IS SHOWN AT 20 VOLTS/CELL PER NEC 480-2.
 5. RECOMMENDED AC OVERCURRENT PROTECTION REPRESENTS UNCONTINUOUS PLUS 125% OF NOMINAL FULL LOAD CURRENT (CONTINUOUS) PER NEC 240-3(a).
 6. MINIMUM SIZED GROUNDING CONDUCTORS TO BE PER NEC 250-95. PARITY SIZED GROUND CONDUCTORS RECOMMENDED.
 7. FOR 3 WIRE, 3 PHASE LOADS (NL), AN INPUT NEUTRAL CONDUCTOR IS NOT REQUIRED. FOR NOTE 1E, FOR LINE TO NEUTRAL LOADS, A NEUTRAL IS REQUIRED FROM THE INPUT SOURCE.
 8. ALL WIRING IS TO BE IN ACCORDANCE WITH NATIONAL AND LOCAL ELECTRICAL CODES.
 9. TOP OR BOTTOM CABLE ENTRY THROUGH REMOVABLE ACCESS PLATES. OUT PLATE TO SUIT CONDUIT SIZE THEN REPLACE.
 10. CONTROL WIRING AND POWER WIRING MUST BE RUN IN SEPARATE CONDUITS.
 11. NEC 310-16, NOTE 10(C) STATES THAT THE NEUTRAL CONDUCTOR IS TO BE CONSIDERED A CURRENT-CARRYING CONDUCTOR. A FULLY-RATED NEUTRAL WIRE IS REQUIRED. HOWEVER, FOR SOME NON-LINEAR LOADS, NEUTRAL WIRE MAY BE SIZED BASED ON THE CURRENT FOR WOKS IN CASE CONDITIONS. THE WIRE SIZE FOR THESE WIRING CONDITIONS SHOULD BE DETERMINED BY THE MAXIMUM NEUTRAL CURRENT SHOWN IN TABLE 1 ABOVE. APPROPRIATE CONDUCTORS SHOULD BE ADJUSTED PER NEC 310-16, NOTE B, WHEN APPROPRIATE.
 12. FOR A 3 PHASE, 4 WIRE OUTPUT, AN INPUT NEUTRAL CONDUCTOR IS REQUIRED. FOR SOURCES OTHER THAN FACTORY SUPPLIED, THE INPUT TO WYE ISOLATION TRANSFORMER MAY BE REQUIRED. CONSULT WITH FACTORY REFER TO NEC ARTICLE 250 & LOCAL CODES FOR PROPER GROUNDING PRACTICES.
 13. WITH THE NEUTRAL ISOLATION OPTION, THE UPS OUTPUT IS A SEPARATELY DERIVED SOURCE. PROVIDE GROUNDING ELECTRODE CONDUCTOR SIZED PER NEC TABLE 250-94.

Figure 13 Cabinet Dimensions

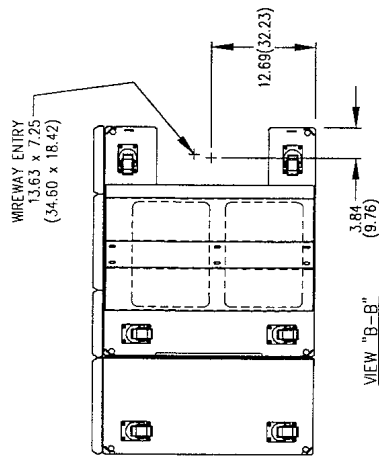

TABLE 2.

BATTERY TYPE	WEIGHT IN LBS. (KG.)
J170L	1210 (550)
J100L	1340 (609)
J140L	1450 (658)
J170L	1710 (776)
J200L	1820 (827)
J270L	2060 (934)
(2)J140L	2200 (998)
(2)J170L	2720 (1234)

- NOTES. (UNLESS OTHERWISE SPECIFIED)
- APPROX. WEIGHT DEPENDS ON BATTERY TYPE. (SEE TABLE 2.)
 - INPUT AIR REQUIREMENT: 1000 CFM.
 - AMBIENT AIR TEMP. RANGE 32-104°F (0-40°C)
 - NOMINAL HEAT GENERATION AT 100% LOAD: 24KVA, 7,200 BTU/HR. 20KVA, 6,500 BTU/HR. 16KVA, 5,300 BTU/HR. 12KVA, 4,000 BTU/HR.
 - DIMENSIONS ARE IN INCHES, THOSE IN PARENTHESIS ARE IN CM. (REF. ONLY)
 - REMOVEABLE ACCESS PANELS FOR UPS INPUT, OUTPUT, AND DC INPUT CABLES, CUT TO SUIT CONDUIT AND REPLACE
 - FOR POWER REQUIREMENTS SEE SINGLE LINE DIAGRAM
 - ALUMINUM AND COPPER-CLAD ALUMINUM CABLES ARE NOT RECOMMENDED.

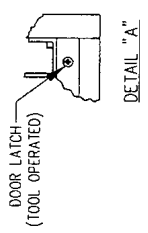
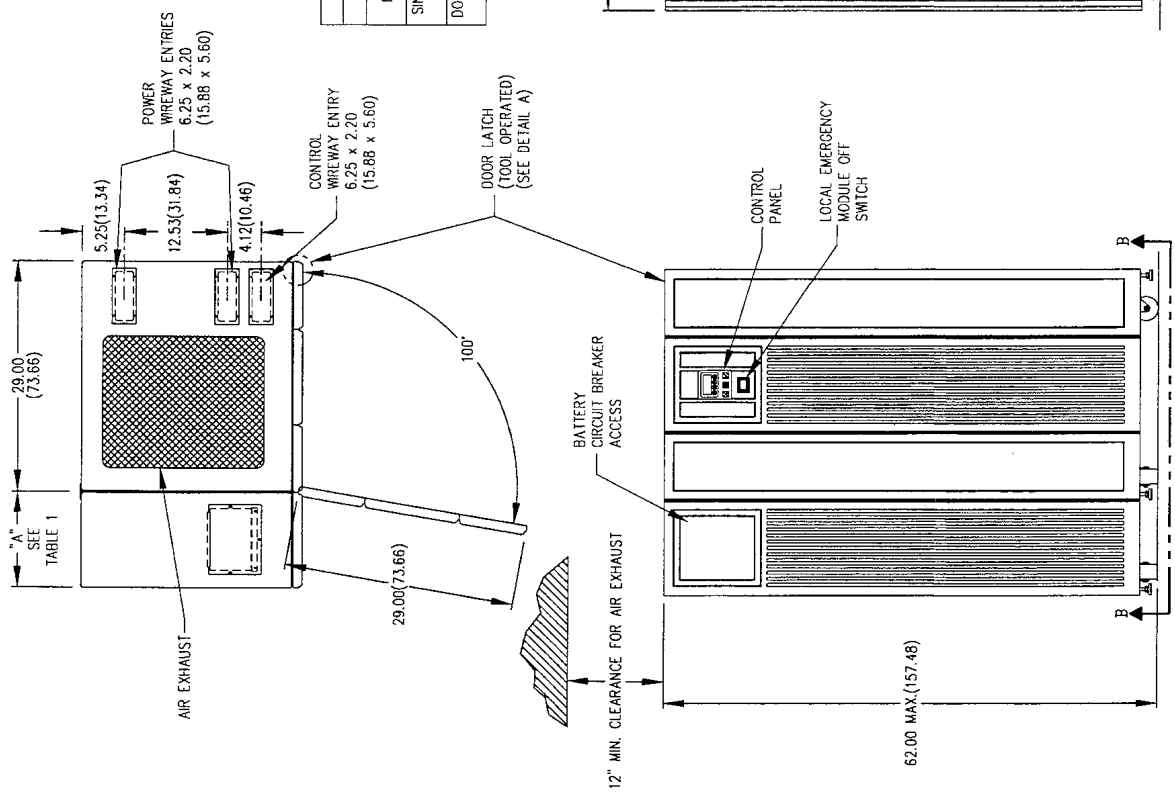
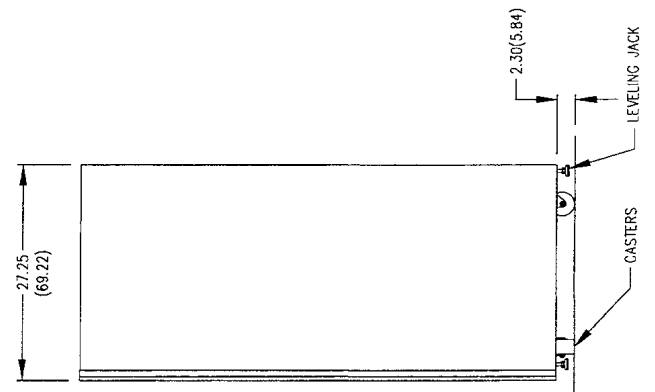

TABLE 1.

UPS MODULE	DIMENSION "A"	MAX. WEIGHT
NO BATTERY CABINET	0"	700 LBS. (318 KG.)
SINGLE BATTERY CABINET	12"	SEE TABLE 2.
DOUBLE BATTERY CABINET	24"	SEE TABLE 2.



TITLE OUTLINE DRAWING UPS Station S3 12-24 KVA 200-240V MODELS	
DRG. NO. US321001	DATE 02-25-97
 <small>1000 DEARBORN DRIVE, P.O. BOX 57000, COLUMBUS, OHIO 43259</small>	

Figure 14 Cabinet Dimensions - With Transformer Cabinet

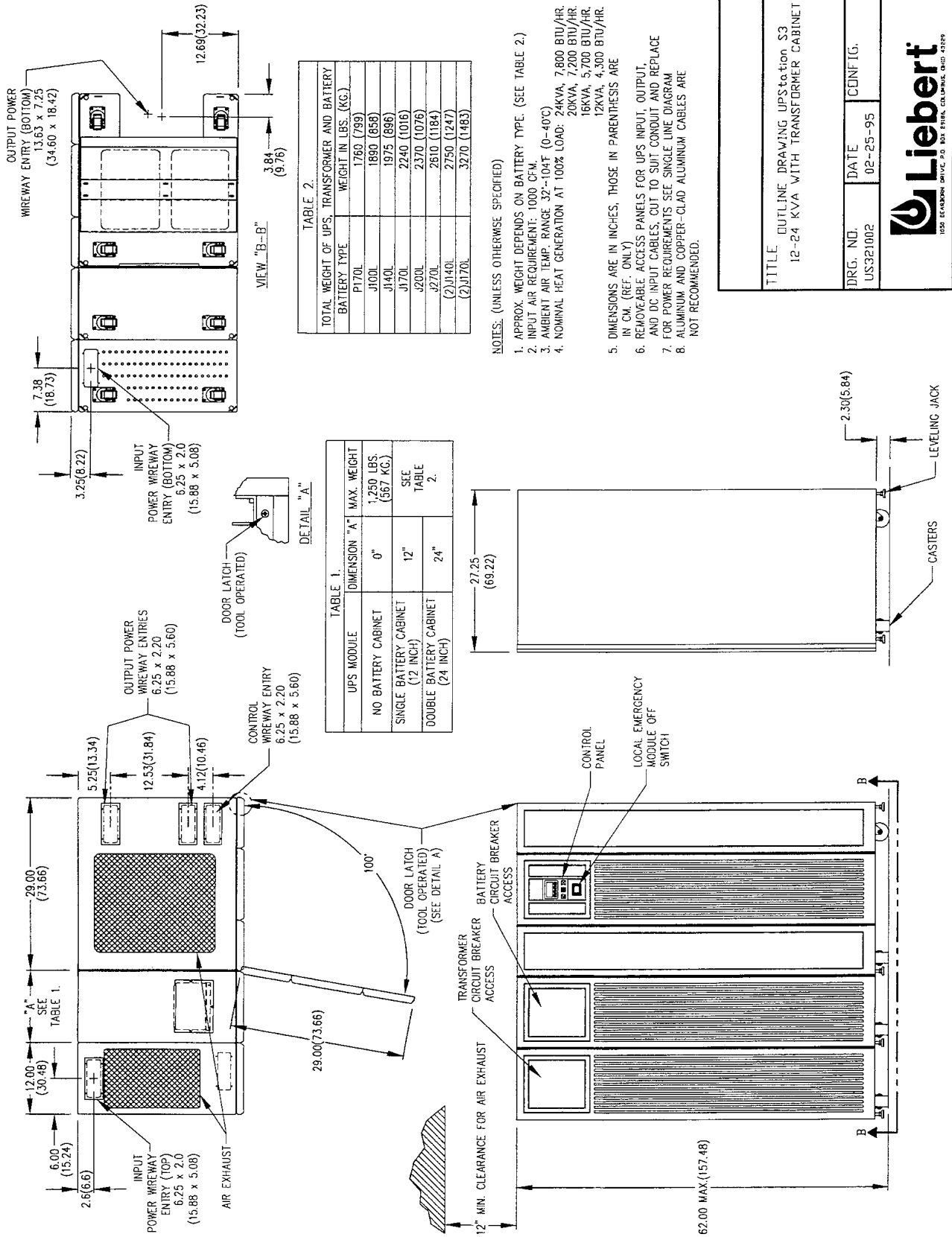

TABLE 2.

TOTAL WEIGHT OF UPS, TRANSFORMER AND BATTERY	BATTERY TYPE	WEIGHT IN LBS. (KG.)
	P170L	1760 (799)
	J100L	1890 (856)
	J140L	1975 (896)
	J170L	2240 (1016)
	J200L	2370 (1076)
	J270L	2610 (1184)
	(2)J140L	2750 (1247)
	(2)J170L	3270 (1483)

TABLE 1.

UPS MODULE	DIMENSION "A"	MAX. WEIGHT
NO BATTERY CABINET	0"	1,250 LBS. (567 KG.)
SINGLE BATTERY CABINET (12 INCH)	12"	SEE TABLE 2.
DOUBLE BATTERY CABINET (24 INCH)	24"	SEE TABLE 2.

- NOTES: (UNLESS OTHERWISE SPECIFIED)
- APPROX. WEIGHT DEPENDS ON BATTERY TYPE. (SEE TABLE 2.)
 - INPUT AIR REQUIREMENT: 1000 CFM.
 - AMBIENT AIR TEMP. RANGE 32°-104°F (0°-40°C)
 - NOMINAL HEAT GENERATION AT 100% LOAD: 24KVA, 7,800 BTU/HR. 20KVA, 7,200 BTU/HR. 16KVA, 5,700 BTU/HR. 12KVA, 4,300 BTU/HR.
 - DIMENSIONS ARE IN INCHES, THOSE IN PARENTHESIS ARE IN CM. (REF. ONLY)
 - REMOVEABLE ACCESS PANELS FOR UPS INPUT, OUTPUT, AND DC INPUT CABLES, CUT TO SUIT CONDUIT AND REPLACE
 - FOR POWER REQUIREMENTS SEE SINGLE LINE DIAGRAM
 - ALUMINUM AND COPPER-CLAD ALUMINUM CABLES ARE NOT RECOMMENDED.

TITLE		OUTLINE DRAWING UPS Station S3	
		12-24 KVA WITH TRANSFORMER CABINET	
DRG. NO.	DATE	CONFIG.	
US321002	02-25-95		

1025 SEWARD DRIVE, P.O. BOX 8788, COLUMBIA, OHIO 43029

Figure 15 Connecting Terminal Details

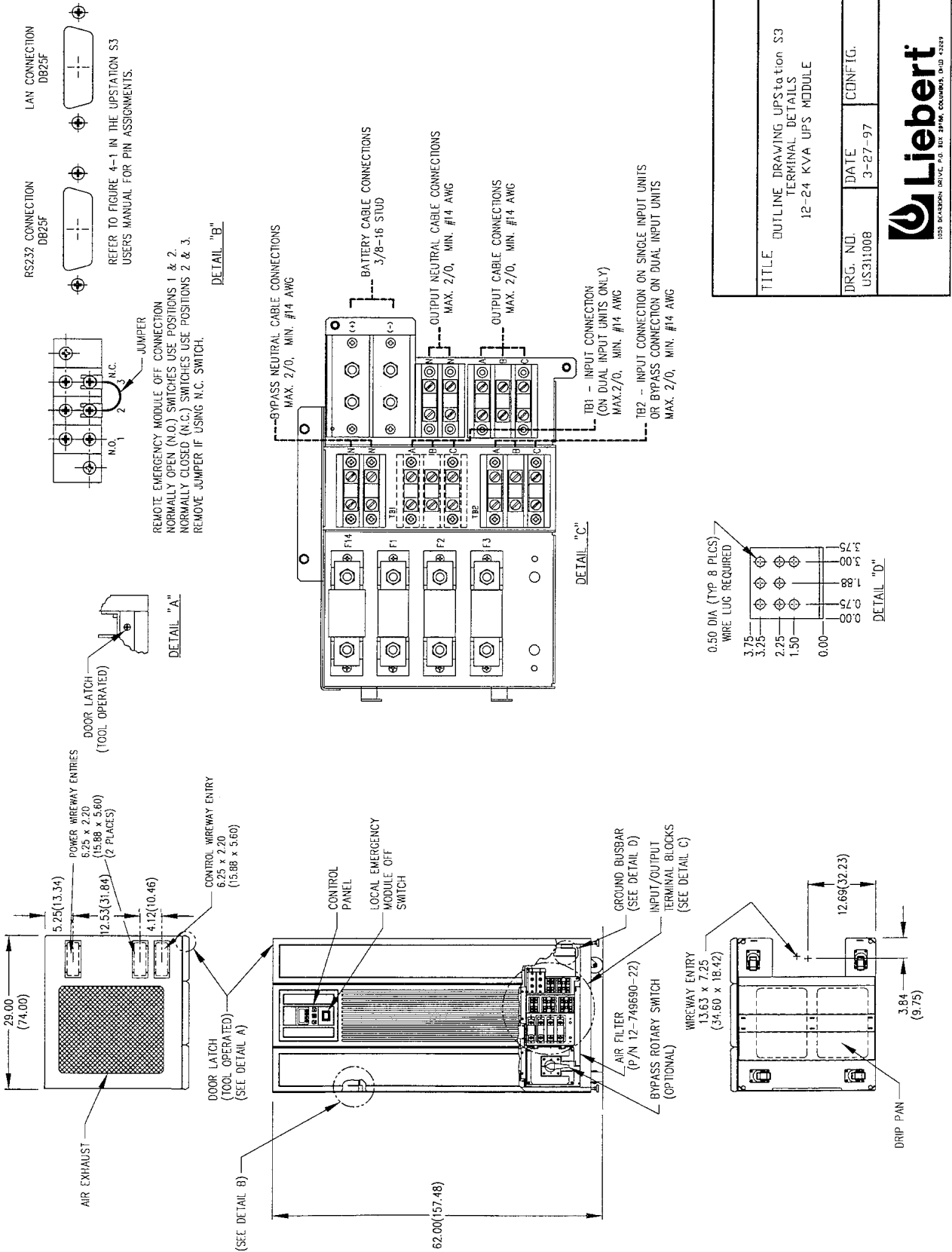

TITLE		OUTLINE DRAWING UPS Station S3 TERMINAL DETAILS 12-24 KVA UPS MODULE	
DRG. NO.	DATE	CONFIG.	
US311008	3-27-97		



Figure 16 Connecting Terminal Details - With Transformer Cabinet

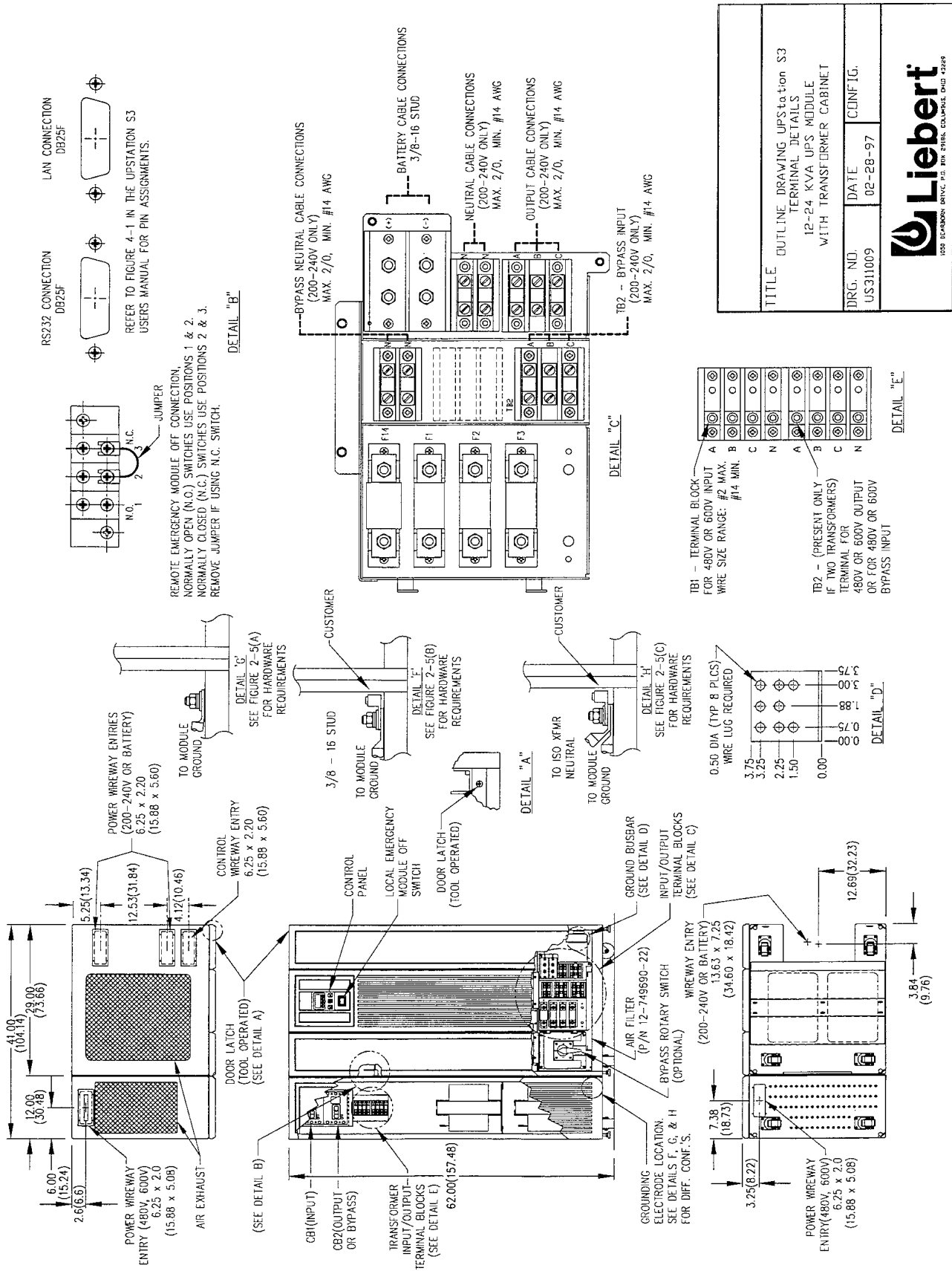

TITLE		OUTLINE DRAWING UPSTATION S3
TERMINAL DETAILS		12-24 KVA UPS MODULE WITH TRANSFORMER CABINET
DRG. NO.	DATE	CUNFIG.
US311009	02-28-97	



Figure 17 Battery Option Details - 12 Inch Cabinet

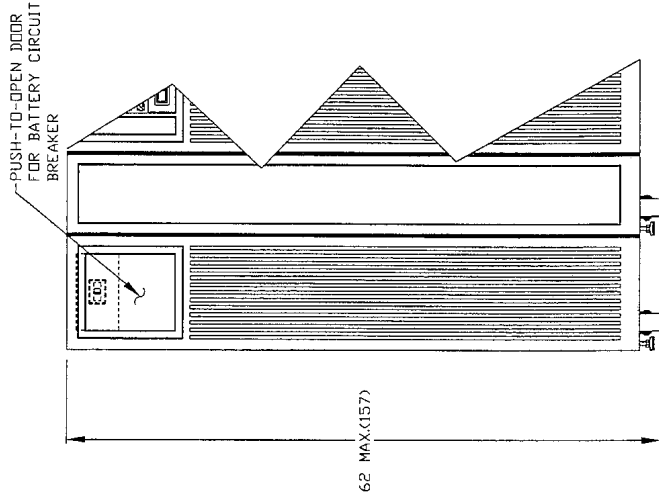

FRONT VIEW

DANGER: BATTERY

1. DO NOT SHORT LUGS TOGETHER OR TO ANY EXPOSED METAL SURFACE.
2. USE ELECTRICALLY INSULATED TOOLS, AND EYE PROTECTION WHEN WORKING ON BATTERY TERMINALS OR WIRE CONNECTIONS.
3. CAUTION: LOADED WEIGHT OF BATTERY TRAY CAN BE UP TO APPROX. 180 LBS. USE CAUTION NOT TO BEND OR DAMAGE BATTERY TRAY TABS.
- 4.

TITLE BATTERY OPTION DETAILS OUTLINE DRAWING	
12-24 KVA UPSTATION S3 WITH FACTORY INSTALLED 12" BATTERY CABINET	
DRG. NO.	DATE
US311003	05-30-97
CUNFIG.	

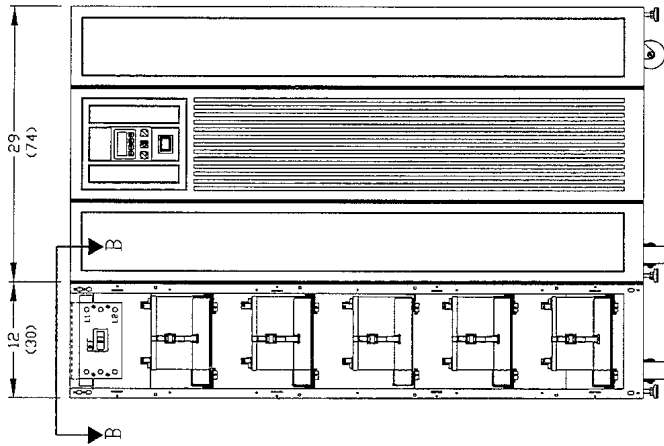

FRONT VIEW WITH FRONT PANEL OF BATTERY CABINET REMOVED

TRAY SHOWN PULLED OUT FOR REF. ONLY. INSTALL BATTERIES FROM BOTTOM TO TOP, (UNIT SHIPS FROM FACTORY WITH BATTERIES INSTALLED.) REMOVE BATTERIES FROM TOP TO BOTTOM. CAUTION: DO NOT ATTEMPT TO REMOVE BATTERY TRAYS LOADED WITH BATTERIES FROM CABINET.

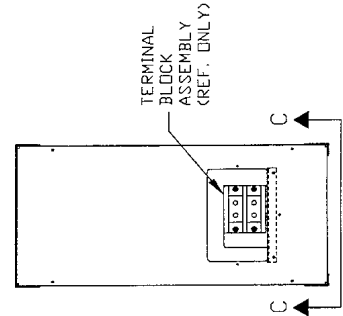
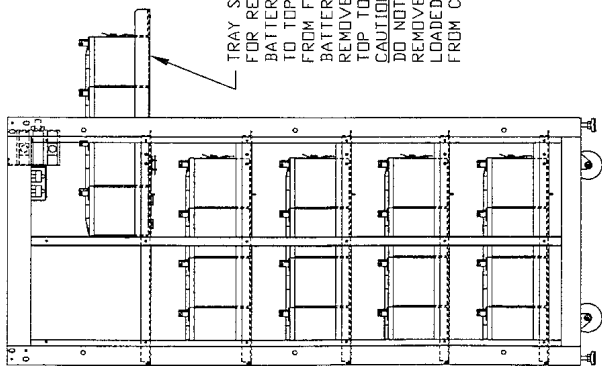

VIEW "B-B"

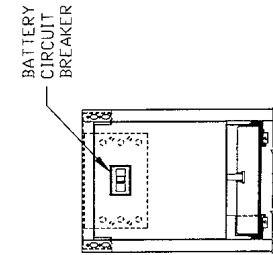

VIEW "C-C"

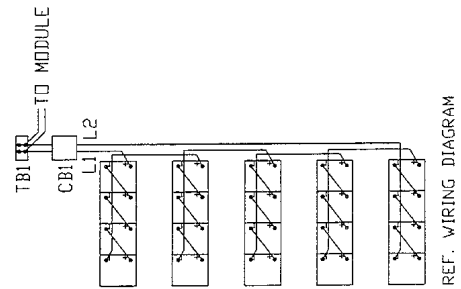
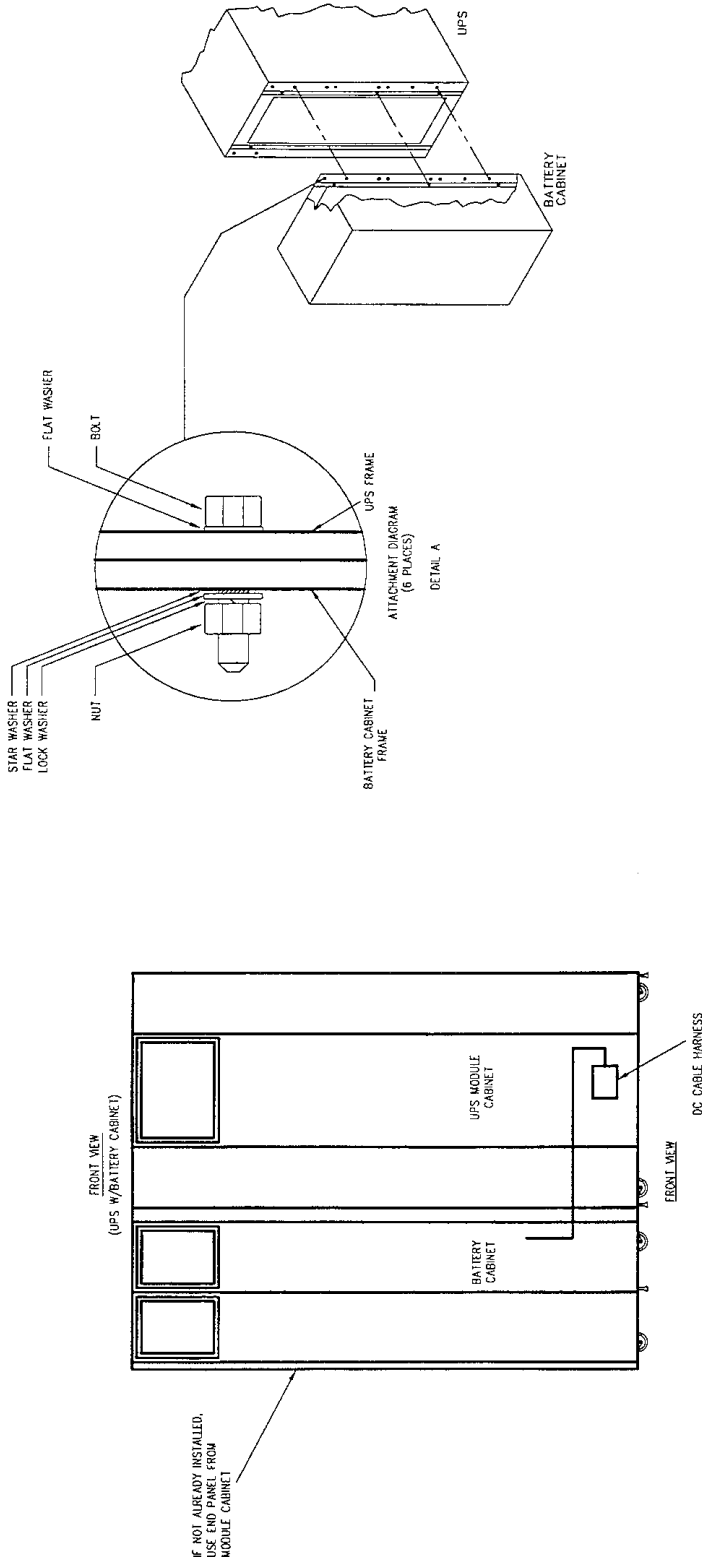

Figure 18 Battery Option Details - 24 Inch Cabinet



NOTES:

1. MINIMUM CLEARANCE: 3 FT. FRONT, 1 FT. TOP.
2. KEEP CABINET WITHIN 15° OF VERTICAL WHILE HANDLING.
3. STANDARD LOCATION FOR BATTERY CABINET IS LEFT-SIDE OF UPS MODULE CABINET.
4. CAUTION: DO NOT CONNECT THE CABLES FROM BATTERY DURING INSTALLATION. (THIS CONNECTION TO BE COMPLETED BY CUSTOMER SERVICE AT START-UP. CABLE HARNESS SHIPPED WITH BATTERY CABINET)
5. UNIT BOTTOM STRUCTURALLY ADEQUATE FOR FORKLIFT HANDLING. NOT RECOMMENDED.
6. ALUMINUM AND COPPER CLAD ALUMINUM CABLES ARE NOT RECOMMENDED.
7. ALL WIRING IS TO BE IN ACCORDANCE WITH NATIONAL ELECTRICAL CODES.
8. RECOMMENDED OPERATING TEMPERATURE RANGE: 20° C (68° F) TO 25° C (77° F)

TITLE		UPSTATION S3 CONNECTION INSTRUCTIONS 24" BATTERY CABINET	
DRG. NO.	DATE	ORDER NO.	
US311018	03-07-97		
 1050 IRVING DRIVE, P.O. BOX 9998, COLUMBUS, OHIO 43229			

Figure 19 Field Lug Wiring Terminations



GROUND ELECTRODE CONNECTION DETAIL 'B'
(WITH AUTO XFMR ONLY)

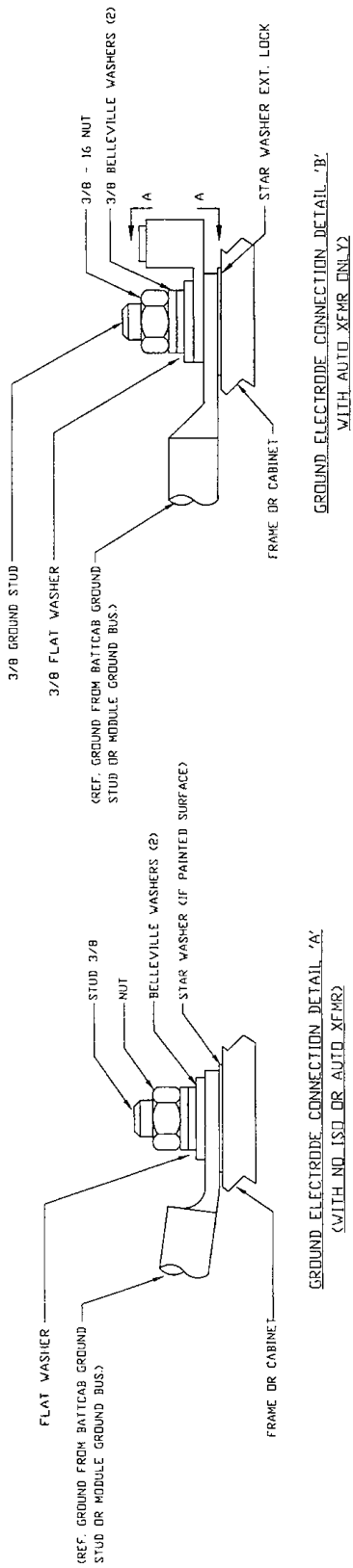
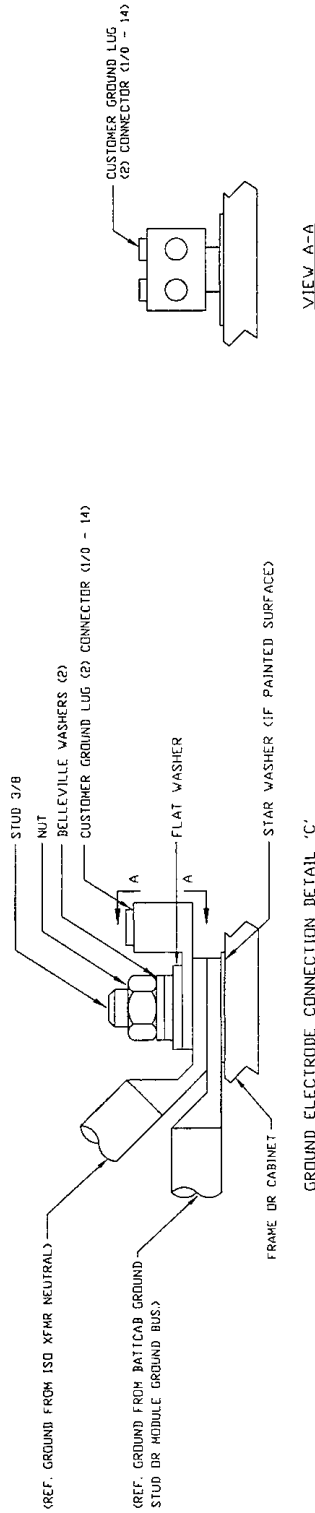

VIEW A-A

TITLE		FIELD WIRING CONNECTIONS FOR LUGGED CABLES	
DRG. NO.	DATE	CONFIG.	
US323001	04-04-97		
 1999 ECHAMON DRIVE, P.O. BOX 4986, COLUMBUS, OHIO 43229			

Figure 20 Unloading Instructions



TITLE	
UNLOADING INSTRUCTIONS UPS Station S3 12-24 KVA UPS MODULE WITH 12' BATTERY OR TRANSFORMER CABINET	
DRG. NO.	DATE
US311011	4-12-95
CONFIG.	
 <small>1005 DEARBORN DRIVE, P.O. BOX 87164, COLUMBUS, OHIO 43269</small>	

Figure 21 Unloading Instructions - 24 Inch Battery Cabinet

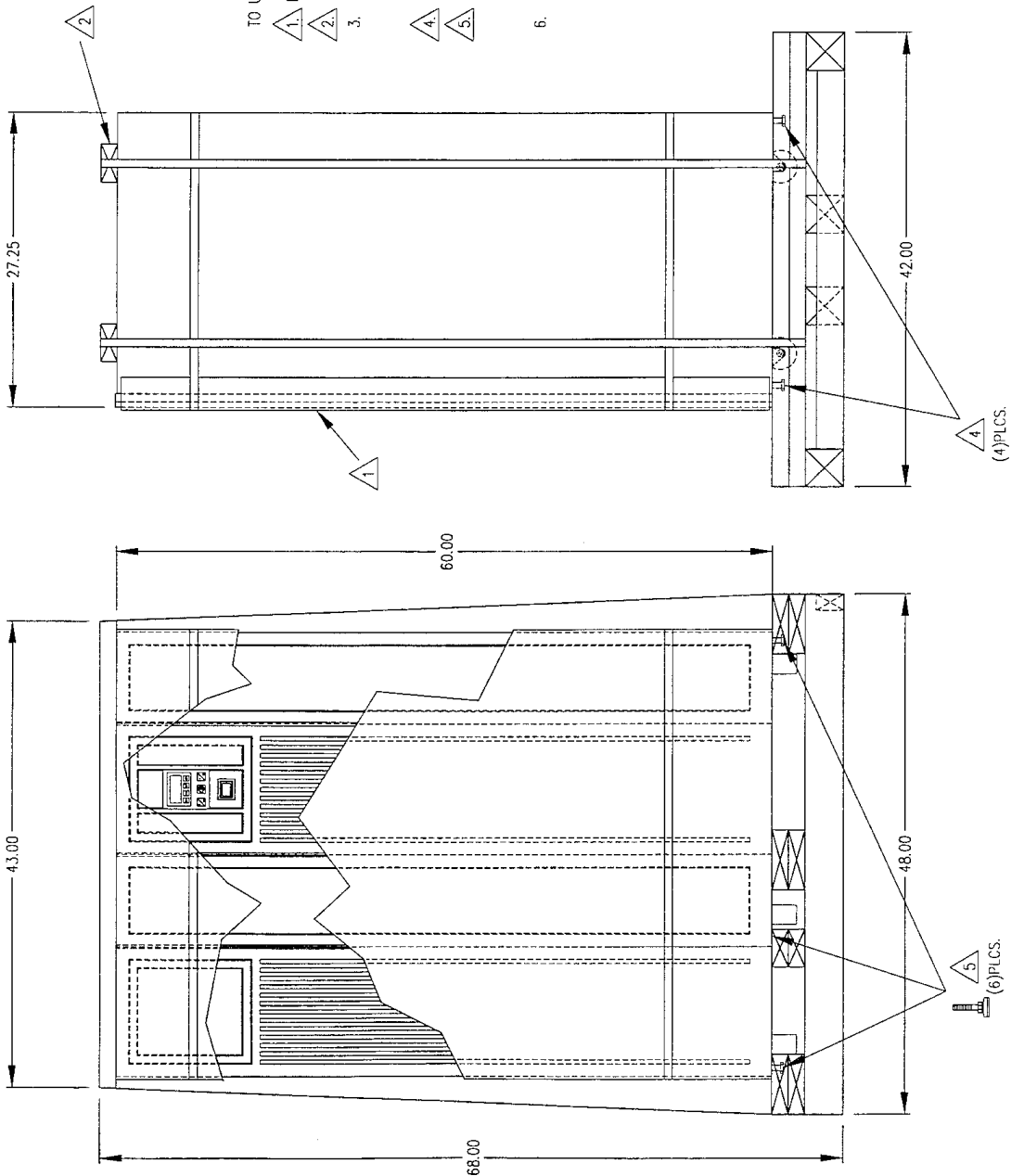

TITLE	
UNLOADING INSTRUCTIONS UPS Station S3 24' BATTERY CABINET	
DRG. NO.	DATE
US311014	04-09-97
CONF'G.	
 <small>1650 EASTERN DRIVE, P.O. BOX 4718, COLUMBIA, MD 21043</small>	

Figure 22 Battery Times

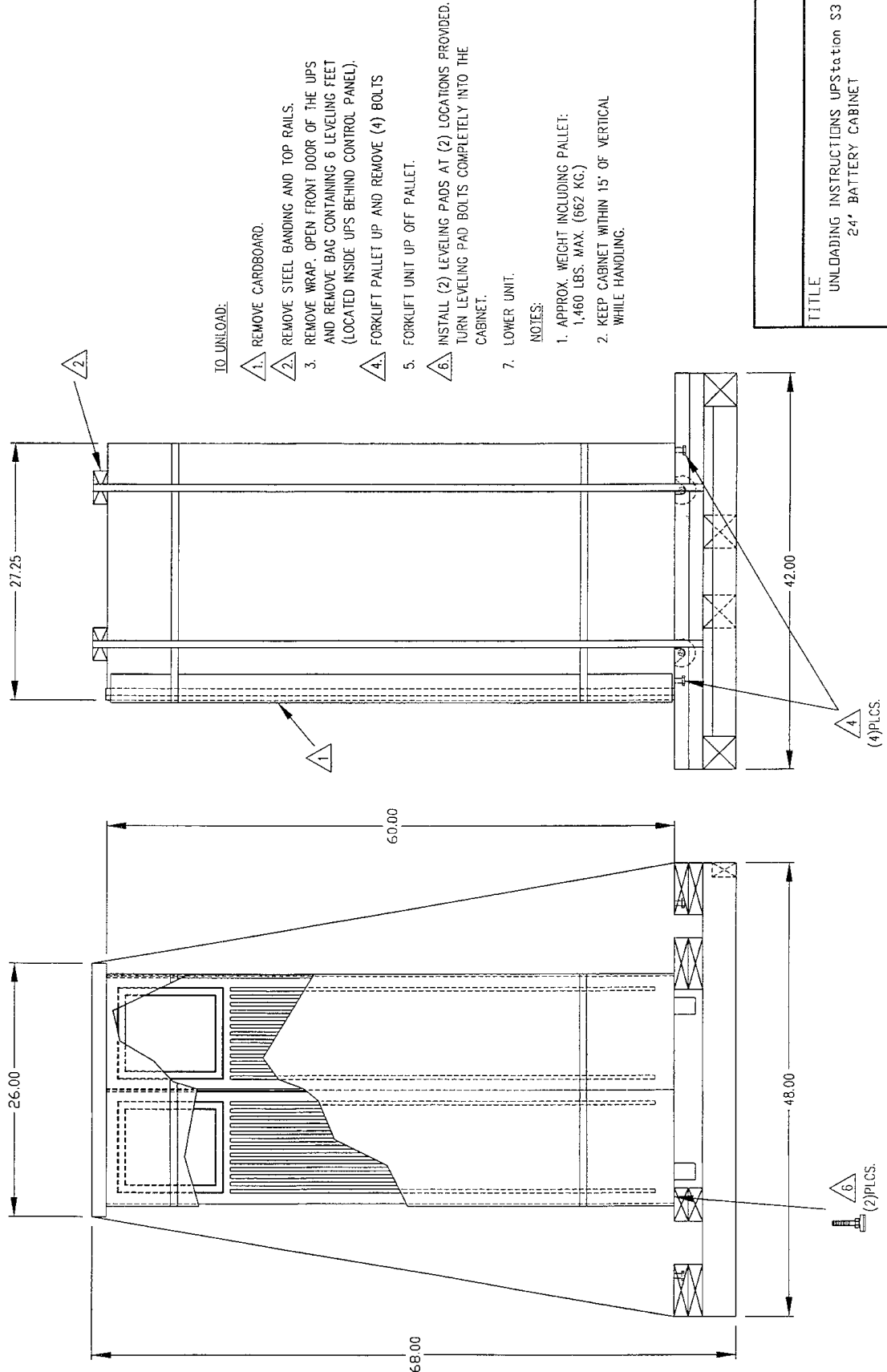

3.0 OPERATION

3.1 Control / Display Panel

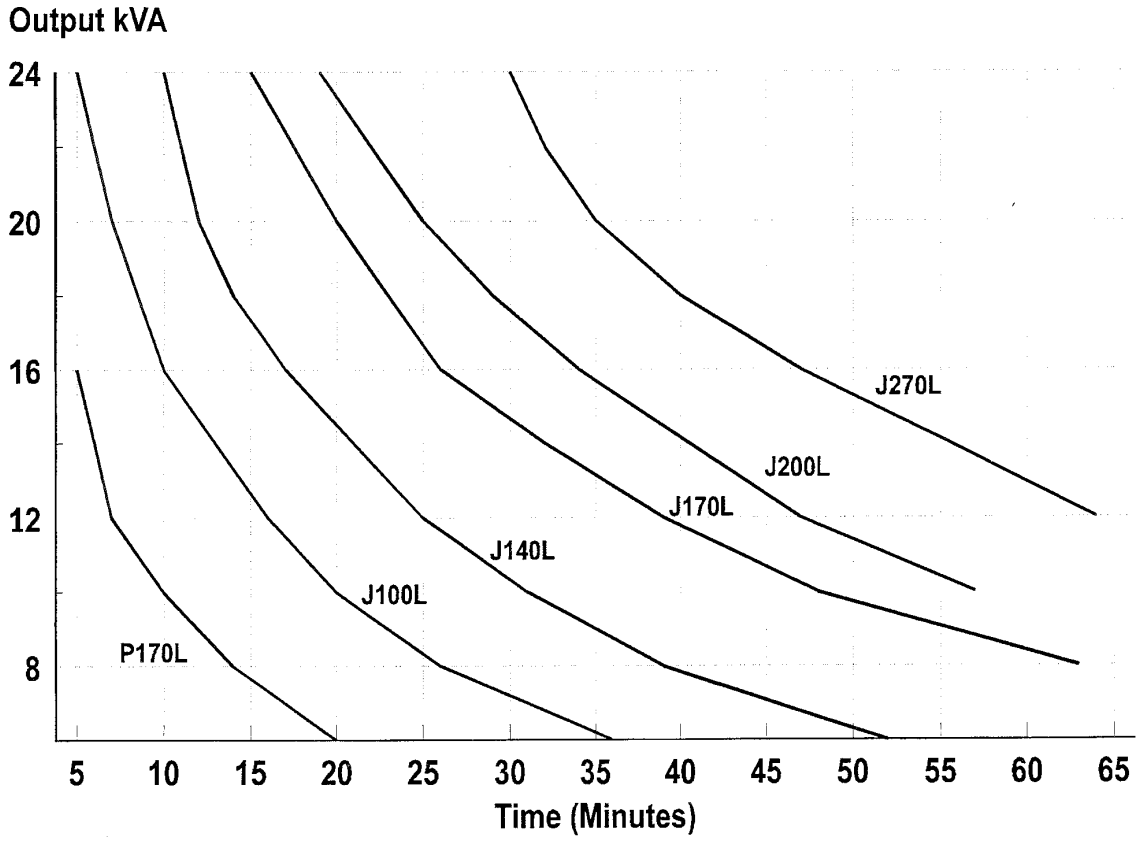
The control panel includes tactile pads (dome buttons) and the LCD (liquid crystal) display which allows advanced operator control. The display indicates present status and alarms, if any. The controls have been designed to make your UPS reliable and easy to operate.



WARNING

BEFORE BEGINNING THE STARTUP PROCEDURE, MAKE SURE THE BATTERY HAS BEEN RECONNECTED. FOR SHIPMENT, ONE OF THE BATTERY INTER-CELL CONNECTIONS IS DISCONNECTED FOR SAFETY. LIEBERT GLOBAL SERVICES PERSONNEL WILL RECONNECT THE BATTERY STRING AS PART OF THEIR START-UP PROCEDURE.

3.1.1 Control Buttons

As shown in **Figure 23**, the control panel includes ON OFF, LEFT ARROW, RIGHT ARROW, ENTER, ESC (escape), ALARM SILENCE AND EPO (emergency power off) buttons.

ON Button

Pressing this button turns on the UPS inverter. Power will be available to the output Terminal Block or Optional Distribution Panel. The ON button also resumes auto-restart capability (if selected) after a manual shut off.

OFF Button

Pressing this button twice within 3 seconds causes an orderly shutdown of the inverter. (If the OFF button is pressed only once, the unit will return to normal operation in a few seconds. This control feature is designed to avoid accidental shutdowns.) All power to loads, including static bypass, is turned off. The display will remain active because control logic power is still available. Also, batteries may still be charging.

Turning the UPS off also disables auto-restart until the ON button is pressed.



NOTE

If you press the OFF button a third time, a display message will prompt you to press the OFF button a fourth time. Pressing the OFF button a fourth time will turn off the battery charger and the PFC function. Logic power will remain on. To remove logic power the Maintenance Bypass Switch must be in the Bypass or Off position.

Alarm Silence Button

Pressing this button silences the alarm horn (beeper). The beeper will sound if a new alarm occurs. The silence button also resets the alarm display if the alarm condition is no longer present.

Note that the beeper and alarm display will remain on (after the alarm condition goes away) until you press the alarm silence button. If the alarm condition is still present, the beeper will be silenced but the alarm message will remain on.

Emergency Power Off Button

Pressing this button will remove all power to the load, by turning off the input converter, the converter and the static switch. The battery remains connected electrically to the module, but there is no output to the load.



WARNING

BEFORE BEGINNING THE STARTUP PROCEDURE, MAKE SURE THE BATTERY HAS BEEN RECONNECTED. FOR SHIPMENT, ONE OF THE BATTERY INTER-CELL CONNECTIONS IS DISCONNECTED FOR SAFETY. LIEBERT GLOBAL SERVICES PERSONNEL WILL RECONNECT THE BATTERY STRING AS PART OF THEIR START-UP PROCEDURE.

3.1.2 LCD Display

Description

The LCD display is menu-driven for ease of use. The LCD display has four (4) lines of text (16 characters per line) on a screen to indicate status, alarms, metered conditions, and user selections. The display controls include four (4) buttons used to view or select UPS conditions (**Figure 23**):

- Left Arrow:** Returns to the previous screen or value.
- Right Arrow:** Advances to the next screen or value.
- Enter:** Selects a menu, display, or value and enters selected values into the control program.
- Escape:** Cancels selections made if an incorrect value was entered and is still flashing. The value will return to the prior setting. Escape also returns the display to the main or next higher menu.

The LCD panel displays messages and operating parameters. A Normal Operation screen is usually displayed (**Figure 23**). This screen includes date, time, and a prompt on the help line to select the Main Menu. If an alarm or fault is present, it is displayed in place of the Normal Operation screen.

Figure 23 LCD Display

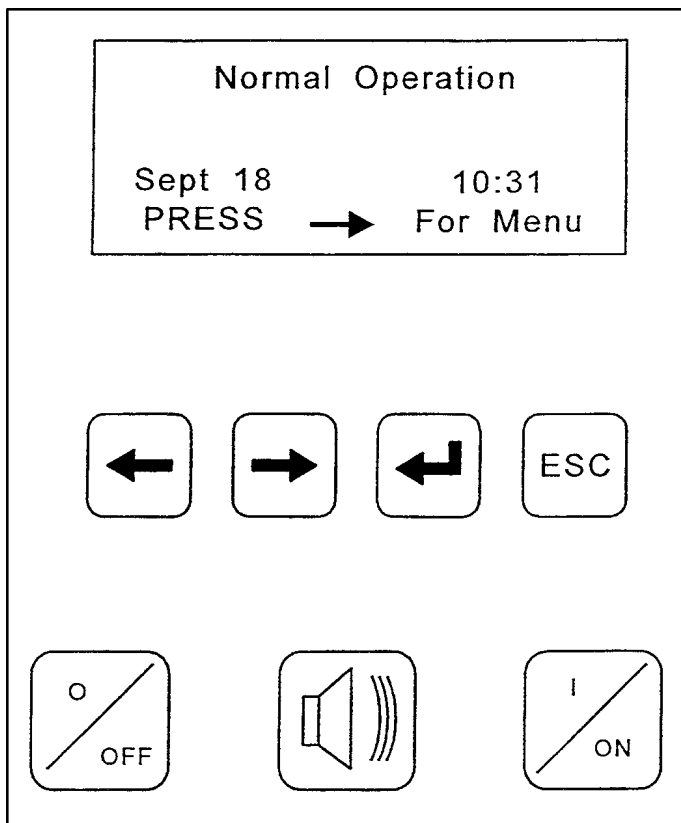

The available user screens are organized in a multi-level menu system (**Figure 24** and **Figure 25**). Each choice is selected by using the keys below the screen. Use the Enter and Escape keys to move from the present menu level to a different one. The Enter key selects the next lower menu level. The Escape key returns you to the previous menu. Use the Left and Right keys to scroll through the available options and to select user programmable values. A cursor will appear on the screen to indicate which value you are programming. Press Enter to record value after each selection.

Initial Start-Up

When power is applied for initial start-up, the LCD display prompts the user to review or change the configuration. The initial configuration menu allows the following selections:

1. Review Configuration
2. Change Settings
3. UPS Meters
4. Accept Settings

After the output configuration is reviewed or changed, then accepted, the system begins start-up self tests. Selected configuration is stored in the control memory, even when input power is turned off.

When power is applied after initial start-up, the self tests begin immediately. Reviewing the configuration is optional.

When the unit is turned off, then on, most of the self tests will not be repeated because power has not been removed from the control logic. The inverter will be tested when the unit is turned on. The number of times the off button is pushed will affect the number of self tests that occur on restart. Pushing the off button twice will turn off the inverter (and thereby power to the load). The PFC (power factor correction) circuit, battery charger and Logic remain on. Pressing an additional 2 times (4 total) will further turn off the PFC and battery charger, leaving only logic power on the system.

To start unit, push the ON button.

User Menus

The Main Menu has the following selections:

1. Configuration
2. UPS Meters
3. Event Log
4. Test Options
5. Power Management (This feature will be available in future versions of this product.)
6. Programmable Output Contacts
7. Programmable Input contacts

Selections 5, 6, and 7 are options. If not installed, pressing <Enter> at these screens will result in the message "This option not installed."

1. Under the configuration menu you can select either review or change for the following items:

Configuration Screen	Default Value
UPS Rating	
Input Voltage	208/120 VAC
Bypass Frequency	60 Hz
Output Voltage	208/120 VAC
Output Frequency	60 Hz
Low Battery warning time	2 Minutes
Auto Battery Test	Enabled (5 wks)
Total UPS Run-time	0 Hrs

Advanced Configuration Screen	Default Value
Input Wiring	L1-L2-L3-N-G
Output Wiring	L1-L2-L3-N-G
Time and Date	Present
Modem Mode	(see 4.0 - Features & Options)
Phone Number	
Phone Number	
Dial Test	
Horn Volume	16 (mid-range)
Screen Contrast	16 (mid-range)
Battery Charger Mode	Slow Charging
Slew Rate	1.0 Hz/Sec
Bypass Frequency sync range	1.0 Hz
Start Up Mode	Auto-Restart
*Set Password	AAAAAAA
*UPS ON(1)/OFF(0)	(remote use)
*Transfer UPS	(remote use)
Battery installed on	(Date)

*In Change Screen only

Note that changes to input or output voltage, frequency, or wiring must be made with the unit turned off. Other changes can be made while the unit is operating.

-
2. You can review the following UPS meters:
 - Load % kVA; A, B, and C Phase.
 - Input Voltage: For each phase the meter will show Phase to Phase (A-B, B-C, and C-A), Phase to Neutral, and Current.
 - Bypass Voltage: For each bypass phase the meter will show Phase to Phase and Phase to Neutral.
 - Output Voltage: For each phase the meter will show Phase to Phase (A-B, B-C, or C-A), Phase to Neutral, and Current.
 - Battery Bus screen will show Volts, Amps, and Charging or Discharging.
 - Frequency: Inverter and Bypass.
 - Temperature: PFC, Inverter and Battery.
 - Inverter Wattage: A, B, and C Phase in kW.
 3. The UPS is delivered with a default password (BAAAAAA). You will need to enter this password at the prompt to be able to change any system parameters or to shut the system down remotely. Entering the password will allow changes to be made for the next 5 minutes. If the machine is left alone you will need to re-enter the password after 5 minutes if you want to make further changes. This will avoid the possibility of unauthorized changes. We recommend you immediately change the password to one known only to the individuals with appropriate authority in your organization. Without entering the password you will not be able to change any of the values in the configuration screens. If the unit is equipped with external communication devices, this will also prevent remote shutdown of the unit without the use of the password.

If for any reason you desire to enable changes to be made to the system configuration menu; without entering a password; without a time-out; or if you wish to be able shut the unit down remotely without a password, you can change the password to AAAAAAA. This will allow open access to changes and remote shut down. We do not recommend the machine be left in this state!
 4. You can review the following recorded event logs:
 - Alarm History.
 - Input Disturbances.
 5. You can perform the following tests:
 - Screen (Enter then ESC).
 - Battery (Enter begins a 30 second test).
 6. Power Management will be available on future editions of this product.

3.2 System Start-Up

3.2.1 Initial Start-Up

Initial Start-Up of the system will be performed by the Liebert Global Services personnel during the start-up of your system.

3.2.2 Manual Restart after Manual Off

If manual restart has been selected (rather than auto-restart) and someone has turned the unit off, press the ON button to turn on the UPS inverter.

3.2.3 Manual Restart after Low Battery Shutdown

If you have selected Manual Restart (instead of Auto-Restart), and the unit has shut down as a result of the battery being depleted during a power outage. Press the ON button to turn on the UPS inverter and the UPS.

3.2.4 Manual Restart after EPO or REPO

If the unit has been shut down via activation of the REPO (customer supplied) or EPO switch, you must clear the latched EPO before you can restart the unit. To clear the logic latch, rotate the Maintenance Bypass switch clockwise to Bypass (6 o'clock position) then follow the procedure below.



CAUTION

Use the following procedure when moving the Maintenance Bypass Rotary Switch from the “Bypass” position. Failure to follow instructions could cause equipment damage or false alarms.

1. Rotate Maintenance Switch from “Bypass” to “Maint”.
2. Pause for 30 seconds and make sure the LCD screen reads “Normal Operation”, with a blinking “Maintenance”.
3. Use the slide switch to set the UPS to Static Bypass. Slide the switch to the left to engage Static Bypass. See Figure 26 for switch location.
4. Rotate Maintenance Switch from “Maint” to “UPS” position (12 o'clock).
5. Return the slide switch to the right, UPS position, and then press “ON” on the LCD panel.

3.2.5 Auto-Restart

This feature is enabled when the unit is shipped from the factory. The UPS will automatically restart and supply power to the load after:

Low battery shutdown (battery supply has been exhausted). Power will be supplied to the load as soon as utility service is restored.

Note that turning the UPS off or using REPO or EPO will disable auto-restart and you will need to follow the procedure in **3.2.4 - Manual Restart after EPO or REPO**.

3.3 Normal Operation

When the utility power is available and within acceptable limits, the unit supplies filtered and regulated power to the load through the converter (input) and inverter (output). The battery charger maintains a charge on the battery.

During normal operation the LCD display will inform you of the UPS status. Normal operation means the UPS is supplying filtered and regulated power to the load. The display will indicate when the load is transferred to or from the bypass (if available), when the load is On Battery, when the battery has passed or failed an automatic test, and if any alarms or faults are present.

To understand the alarm messages, refer to **3.7 - User Response to UPS Alarms**.

3.4 Battery Operation

3.4.1 On Battery

During low input voltage the battery will supplement the power to the inverter. During a utility power failure the battery will provide all of the input power required for normal operation. Internal battery capacity varies with the battery cabinet selected with the UPS or with the battery supplied by others. The battery capacity will be available if the battery is fully charged at the beginning of a power failure. More battery capacity can be obtained by adding optional battery cabinets. Refer to **4.0 - Features & Options**. If the load is less than the full rated load, the battery time will be increased. Note that decreasing the load during a power failure will increase battery time. Therefore, if your UPStation S3 UPS is supporting several computer systems, turning some of them off will allow the remaining one(s) to run longer.



NOTE

If utility power remains off, perform an orderly shutdown of the critical load before the battery reaches its time limit.

If utility power returns during battery operation, normal operation will resume and battery recharging will begin.

3.4.2 Battery Recharge

Upon return of acceptable utility power after battery operation, the battery charger begins to charge the batteries. Battery charging is disabled if the OFF button has been pressed four times or if the REPO button is pressed.

The battery charger compensates for battery temperature. In addition, the charger has two recharge rates, user-selectable through the optional LCD display. The fast or “turbo” rate will recharge the batteries to 95% capacity within 10 times the discharge duration. The “slow” rate (factory default) will recharge the batteries to 95% capacity within 20 times the discharge duration. Retain the “slow” rate if your utility system has frequent (weekly) blackouts.

When the “turbo” mode is enabled, the microprocessor determines how often to use the fast recharge rate, in order to optimize battery life.

3.5 Bypass Operation

A factory-installed Static Transfer Switch provides an alternate path for power to the critical load that can be selected by the microprocessor.

3.5.1 Static Transfer Switch

In the event of overload conditions or inverter failure, detection and automatic phase synchronized transfer to (and from) the static transfer switch will occur.

Figure 24 LCD Menu Tree

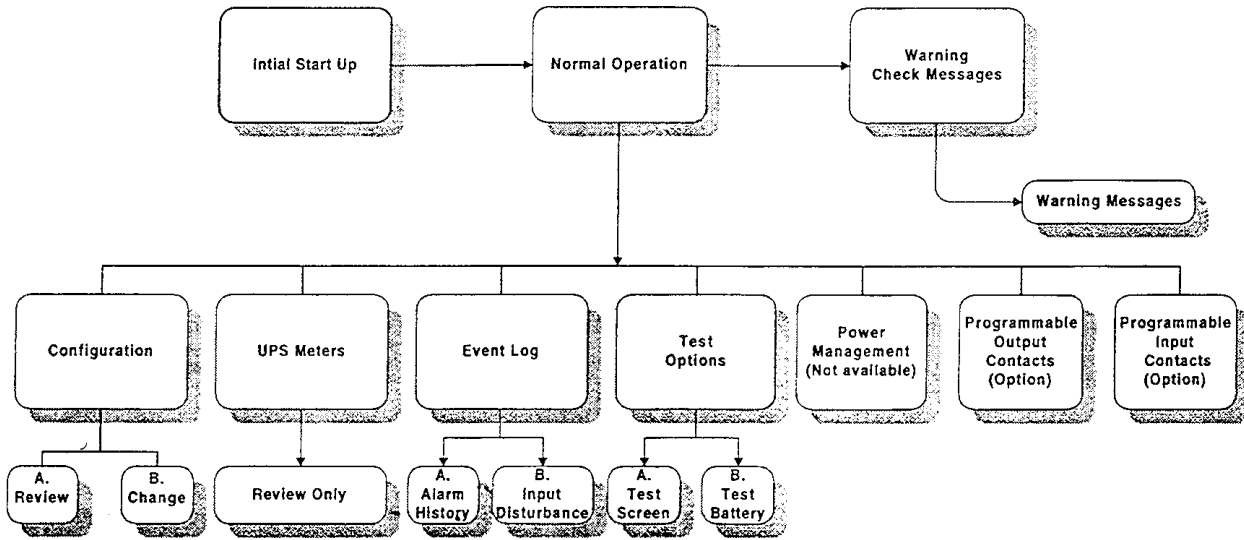

One of the three default screens will show on the unit depending on the status of the unit at the time. If the unit is in the process of starting up the Initial Start Up screen will be displayed. If the unit is operating normally, the Normal Operation screen will be displayed. In the event there are alarms present, the Warning screen will be displayed.

Toggle between screens by pressing enter to descend in the menu and escape to move up through the menu. This drawing is only an overview representation of the available screens.

For further detail on Configuration Options, see **Figure 25**.

Figure 25 Configuration Menu Tree

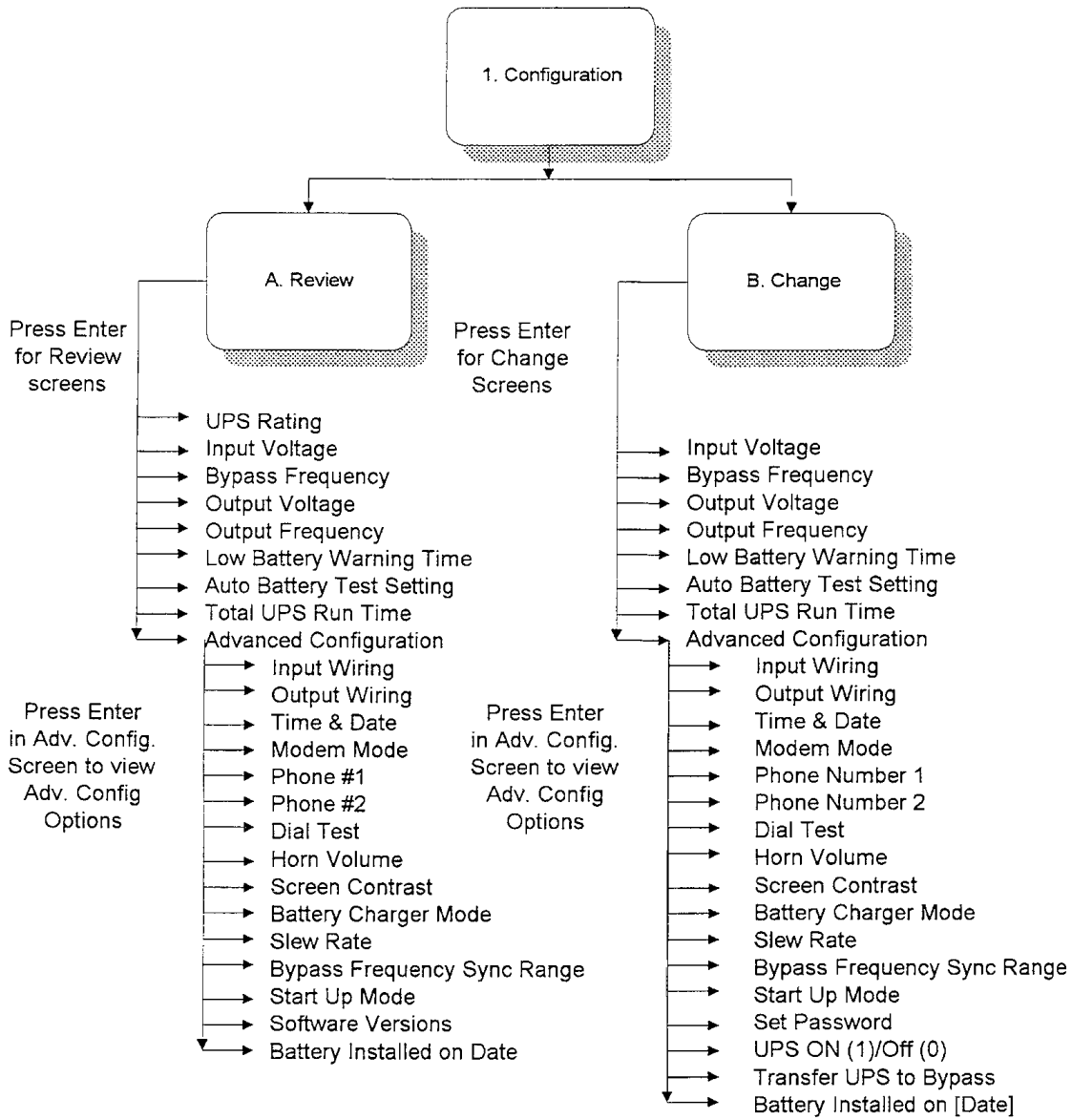

3.5.2 Maintenance Bypass



CAUTION

Improper operation of the Maintenance Bypass switch can cause the unit to shut down. Follow the instructions carefully and observe all requirements to pause between switch operations.

The UPStation S3 is equipped with a Maintenance Bypass Switch (see **Figure 26**), the bypass path for power to the critical load can be manually selected by the user if there is a need to isolate certain parts of the UPS for maintenance or in case of some UPS faults. User selection of the manual bypass is made by a switch inside the front door in the bottom left front of the cabinet. Open front door (release locking screw).

The switch is a 360-degree switch that can be rotated either clockwise or counter-clockwise.

- When the switch is in the vertical position (pointing at 12 o'clock) the UPS mode is selected. This is the normal operating mode of the UPS.
- When the 9 o'clock or left position is selected all power is turned off including that to the load. The Battery is still on. Use the circuit breaker to turn off the battery.
- In the 3 o'clock or right position the UPS is turned on, however the load has been disconnected and is being fed by the bypass line. There is still power to the logic. High voltage is present in the unit. This is the "maintenance" position and should only be used by trained Liebert Global Services personnel when diagnosing system faults.
- Finally, in the 6 o'clock position or pointing down the switch has selected the manual bypass position and the unit is bypassed with the utility providing power to the load. All functions of the UPS are powered off including the logic. The Battery is still on. Use the circuit breaker to turn the battery off.



CAUTION

To return the Maintenance Bypass switch back to the UPS position follow the CAUTION procedure in 3.2.4 - Manual Restart after EPO or REPO.

3.6 System Shutdown

3.6.1 Manual Off

Pressing the OFF button twice will remove power to the load by turning off the inverter and opening the Static Transfer Switch.

When you turn off the UPS with the OFF button, the control logic and battery charging are still active, and auto-restart is disabled until you press the ON button.



NOTE

If you press the OFF button a third time, a display message will prompt you to press the OFF button a fourth time. Pressing the OFF button a fourth time turns off the battery charger, control logic remains on.

3.6.2 Automatic Off

The UPS inverter will automatically turn off if:

1. The overload capacity and duration are exceeded,
2. Battery capacity is exhausted, or
3. An internal fault is detected during self diagnostics.

The UPS will transfer to bypass in case of overload or fault.

3.6.3 Remote Emergency Off

Each unit includes a Terminal Block in the unit to enable Remote Emergency Power Off (REPO) from a customer-supplied switch. Activating the emergency off will turn off the converter, inverter and static switch.

Figure 26 Control Switch Locations

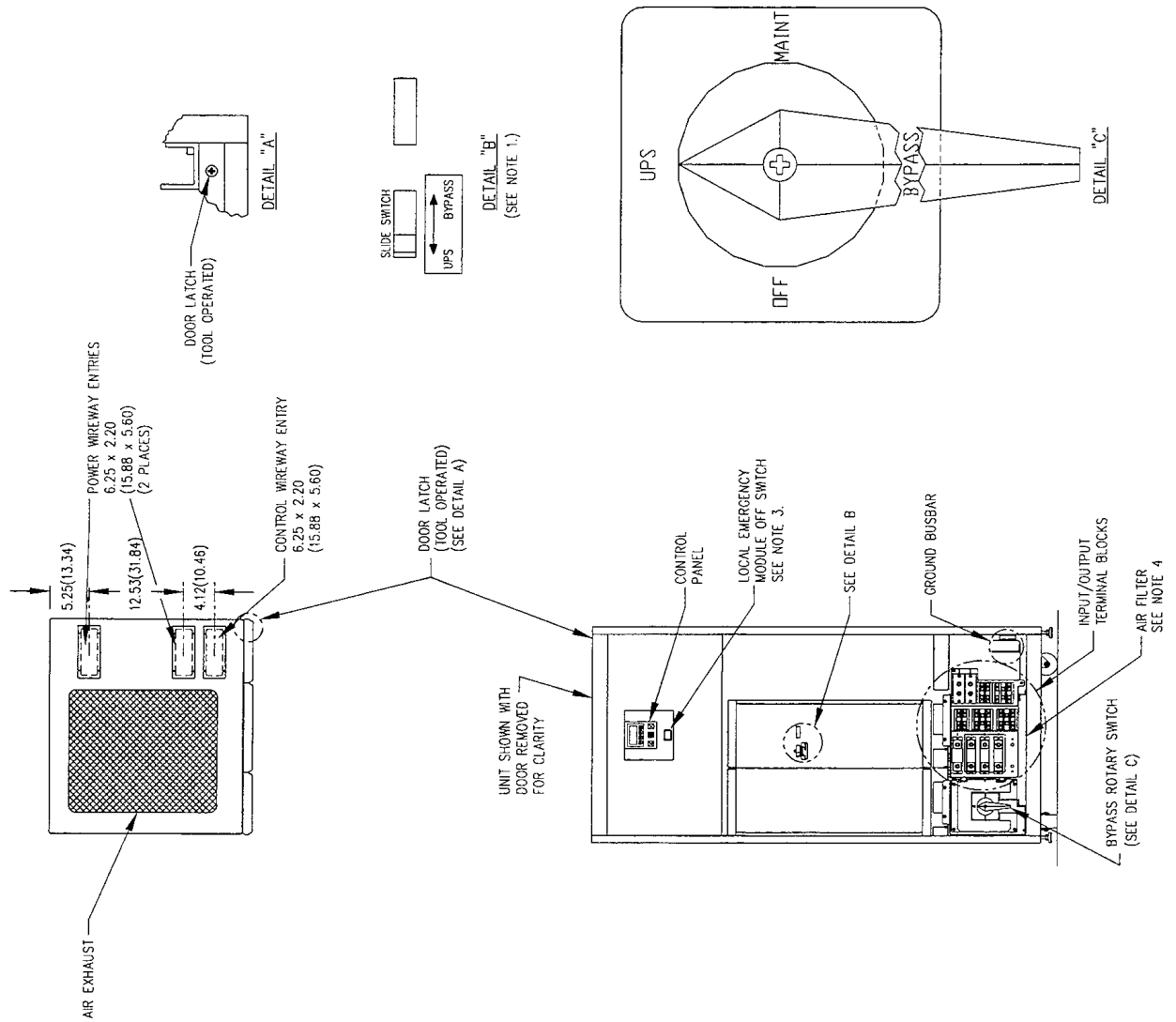

NOTES:

1. SLIDE SWITCH MUST BE IN UPS POSITION AS SHOWN FOR NORMAL OPERATION. (USE FRONT, LCD CONTROL PANEL FOR MANUAL TRANSFERS).
2. BYPASS ROTARY SWITCH MUST BE IN UPS POSITION AS SHOWN FOR NORMAL OPERATION. REFER TO LIEBERT UPSTATION S3 USER'S MANUAL SECTION 3.5 FOR OPERATING INSTRUCTIONS.
3. THE LOCAL EMERGENCY MODULE OFF BUTTON TURNS OFF THE INVERTER AND STATIC SWITCH OUTPUTS ONLY. THIS SWITCH DOES NOT AFFECT THE OPTIONAL BYPASS ROTARY SWITCH. LOAD WILL STILL BE ENERGIZED IF THE ROTARY SWITCH IS IN "MAINT." OR "BYPASS" POSITION. TURNING THIS SWITCH TO "OFF" WILL REMOVE ALL POWER TO THE LOAD.
4. DOOR MUST BE OPENED TO REPLACE AIR FILTER. (AIR FILTER SIZE DISPOSABLE 1.0 x 14.50 x 24.50, TOLERANCE +0.00", -0.25". LIEBERT P/N 12-748690-22)

TITLE		OUTLINE DRAWING UPStation S3	
		12 - 24 KVA	
		CONTROL SWITCH LOCATIONS	
DRG. NO.	DATE	CONFIG.	
US311005	3-27-97		
Liebert			
100% RECYCLED PAPER. 100% SOY INK. CALIFORNIA, 0600-2128P			

3.7 User Response to UPS Alarms

If the UPS is operating normally, the “Normal Operation” screen as shown in **Figure 23** will appear on the LCD display. If there is a system error or problem of some type the UPS will display one of the following screens. Most of these screens request that the operator “Check Messages”. By scrolling the menu as indicated the operator will display the specific alarm. Sometimes the alarm can be found in the Event Log - Alarm History. Refer to **Table 5**, where alarms are listed alphabetically. This table displays the alarm messages and operator corrective action, if any. Perform the corrective action if one is described. Phone Liebert Global Services at **1-800-543-2378** if you require assistance.



NOTE

If the Alarm is sounding and the display message is “REPLACE AIR FILTER”, pressing the alarm silence will silence the alarm, however to remove the error message you need to replace the air filter in the unit and reset the warning screen. To do this, go to the replace air filter warning screen and press the left and right arrow keys simultaneously. After 30 seconds the warning screen will clear, and the filter warning will be reset. The filter warning is set for 3 months. If you find your filter is staying clean you can have the Liebert Global Services personnel adjust the warning period.

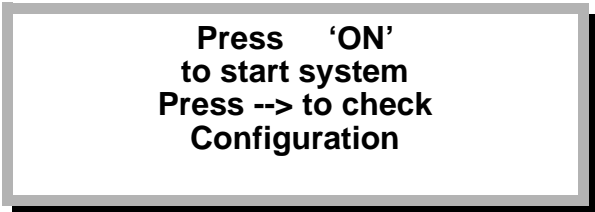

**Press 'ON'
to start system
Press --> to check
Configuration**

This message will only be seen if there is a temporary fault during the start up sequence. Press On and retry the starting sequence. If the error persists contact Liebert Global Services.



WARNING:

Check Messages -->

This message is a warning of potential problems, check the alarm messages and follow the appropriate actions in **Table 5**.



**UPS ON BATTERY
Time Remaining
Minutes
Check Messages -->**

The UPS has gone to battery. This screen indicates the time remaining on battery. Scroll to the alarm message to determine the cause of the transfer to battery. Take appropriate action as suggested in **Table 5**.

**WARNING:
Load on
Bypass
Check Messages -->**

The UPS has transferred to its bypass source. Scroll to the alarm message(s) to determine the cause of the transfer to bypass. Take appropriate action as suggested in **Table 5**.

**SYSTEM SHUTDOWN
Check Messages -->**

The UPS system has suffered a major fault and has shut down. Call Liebert Global Services **(1-800-543-2378)** immediately. Scroll to the alarm messages in the Event Log and record them. Take appropriate action as suggested in **Table 5**.

Table 5 Alarm Messages

Alarm Message	Meaning	Corrective Action
Alarm Event	The Input contact isolator allows the user to define events outside of the UPS that will cause an alarm to show on the UPS. One of those events has occurred.	Scroll through the alarm messages to determine which outside alarm has occurred. Correct the alarm source and the alarm message will clear.
Bad Connection	An internal connection between PC boards has come loose or is broken.	Contact Liebert Global Services.
Battery Charger Inhibited: load above threshold	The input contact isolator option has triggered inhibition of the battery charger and the load is above the threshold selected by the user to inhibit battery charging.	This alarm normally comes when the unit is being fed by an alternate source such as a generator. Battery charging has been temporarily inhibited to reduce the load on the secondary source. If the normal utility is supplying the load check the programming of the ICI option in the User's Option Manual. If the unit is being temporarily supplied by a secondary source, try to reduce the load below that sources capacity so the system can resume charging. Contact Liebert Global Services if you have questions or problems.
Battery Test Failed	The battery test has detected a weak battery.	If there is no charger alarm, then the battery has either weak cells or loose connections. Contact Liebert Global Services for battery service.
Battery Voltage Unstable	A battery cell(s) is not functioning properly or battery system wiring is loose.	Contact Liebert Global Services for battery service.
Bypass Out-of-Sync	Bypass input is not stable. UPS inverter output is not synchronized with the input power. Automatic transfers to bypass are prohibited. This is usually a temporary condition.	If the problem does not correct itself in 15 minutes contact Liebert Global Services. Check utility source.
Bypass Overload	An overload condition has exceeded the capacity of the bypass. If not corrected a fuse will blow resulting in a system shutdown.	Correct the overload condition. Call Liebert Global Services if the condition persists.
Bypass Power Supply Failure	Control power is outside the acceptable limits. Bypass is not available.	Contact Liebert Global Services.
Bypass SCR Short	The system has sensed unexpected input voltage. The UPS will transfer to bypass.	Contact Liebert Global Services.
Bypass Sensing Failure	Unit will transfer to bypass due to an internal sensing failure.	Contact Liebert Global Services.
Bypass Voltage Out of Tolerance Incorrect Bypass Input Frequency	Input power voltage or frequency is outside of the specified tolerance. Automatic transfers to bypass are prohibited except in the case of inverter failure.	In this condition a manual transfer to bypass is not recommended because it will be a momentarily interrupted transfer.
Can't Execute Battery Test: Not Recharged	The battery has discharged too recently (within 72 hours of the scheduled test time).	No corrective action is required. The next scheduled battery test will be performed.

Table 5 Alarm Messages (continued)

Alarm Message	Meaning	Corrective Action
Charger Battery Voltage High Charger Battery Voltage Low	The DC voltage of the battery charger is outside the specified limits and the charger has been turned off. The charger will automatically restart when the DC bus voltage returns to within tolerance.	Make sure battery breaker is closed. Contact Liebert Global Services if this condition persists for more than 15 minutes.
Charger Fuse Blown	The battery circuit breaker is open or the battery charger fuse has been blown. The charger is no longer charging the batteries.	Check the battery circuit breaker. If the breaker is open, try to reset. If the breaker will not reset or is not open, Contact Liebert Global Services.
Charger Hardware Shutdown	Malfunction in the battery charger section. If this condition persists without service, the batteries can be discharged.	Contact Liebert Global Services.
Dial Out Attempt Failed	If the unit is equipped with an internal modem, it attempted to dial out due to an event or command on the modem connected to the UPS. The attempt was unsuccessful after 3 tries.	Check the phone number programmed into the modem. Check the receiving modem. Check the modem operation.
Excessive Retransfers Attempted	Several automatic retransfer attempts (20 attempts during 15 minutes or less) have been made to retransfer the load from bypass (if available) back to the UPS. The UPS has not been able to consistently sustain the load, because of an overload condition or an inverter failure. The load will remain on bypass.	Check other messages for inverter failure. Determine cause of the overload and reduce the load. If the problem cannot be corrected, call Liebert Global Services.
Emergency off. Recycle input to restart.	The UPS has been shut down from an external contact (REPO) or the front panel EPO switch.	Perform a UPS start-up procedure when the conditions causing the external shutdown have been corrected. See 3.2.3 - Manual Restart after Low Battery Shutdown .
Fault Transferred to Bypass	The unit transferred to bypass due to a fault or overload in the system. This alarm accompanies the other alarms that caused the fault.	Review other alarms. Remove condition-causing fault if possible (e.g., reduce overload). Call Liebert Global Services if fault cannot be cleared.
Ground Fault detected on DC bus.	There is a ground fault in the battery cabinet or battery wiring.	Contact Liebert Global Services immediately.
Input Voltage Out-of-Tolerance	The line to line voltage of the input power is outside the acceptable range. In this situation, if the voltage is low the battery will supply power to the critical load through the UPS.	If this condition persists the battery will eventually completely discharge. Check your electrical wiring. Check with your utility.
Inverter Fuse Blown	The inverter fuse has opened indicating a failure in the inverter section of the UPS. The unit will transfer the load to Bypass.	Contact Liebert Global Services immediately.
Inverter Neutral SCR Open	On units equipped with the isolated neutral option, the SCR has failed.	Contact Liebert Global Services.
Inverter Startup Overvolt	The inverter bus is too high during the walk-in period. Possible fault on the PFC.	Contact Liebert Global Services.

Table 5 Alarm Messages (continued)

Alarm Message	Meaning	Corrective Action
LAN Interface Shutdown Initiated	This alarm indicates the LAN is being shut down for a programmed action due to the activation of one or more alarms.	This should activate the automatic shutdown sequence programmed into your LAN operating system.
Load on Manual Bypass	The Maintenance Bypass switch is in the Maintenance position.	When the maintenance activity has been completed, return the unit to normal operation.
Logic Error	Automatic diagnostic testing has detected a failure (of hardware or software) in the UPS internal control system. A second message may indicate internal test or software time-out. The load has been automatically transferred to bypass.	Record the alarm condition and contact Liebert Global Services.
Low Battery Shutdown	Battery has discharged to the minimum allowable voltage. If the bypass is available the unit will transfer to bypass. If the bypass is not available, the UPS is shut down. No power is being supplied to the critical load.	When the battery has recharged and if there is not fault, the unit will retransfer from bypass. If bypass was not available, when input power becomes available, perform a UPS start-up procedure. Unit will start-up by itself if auto-restart is enabled.
Low Battery Warning Issued	The battery voltage measurement has reached the user-programmed warning value. The unit will shut down at the specified time if input power is not restored.	User should take appropriate measures to insure an orderly shutdown of the system. If the user has set the warning level above 2 minutes, you may also take action to shed load and increase battery time to complete discharge.
Manual Off Activated (Alarm History Only)	The UPS has been shut down remotely through the RS-232 interface or through the advanced configuration menu.	To restart the UPS follow the procedures in 3.0 - Operation .
Manual On Activated (Alarm History Only)	The UPS has been turned on remotely through the RS-232 interface or through the advanced configuration menu.	This is an information alarm only. Make sure it is OK that the UPS is energized.
Manual Transfer-to-Bypass Activated (Alarm History only)	The UPS has been transferred to bypass remotely through the RS-232 interface or through the advanced configuration menu. The UPS stays on Bypass until the retransfer is activated and all required conditions for retransfer are satisfied.	Determine why the UPS was transferred to bypass. Clear the fault or problem and retransfer to normal operation. If the problem cannot be corrected, contact Liebert Global Services.
Memory Failure ROM or Memory Failure RAM	The microprocessor has failed a self diagnostic test during the start-up process. Start up will not be allowed.	Contact Liebert Global Services.
Neutral SCR Short	On units equipped with the isolated neutral option, the SCR that transfers the neutral has failed short.	Contact Liebert Global Services.
Non Volatile Ram U88 Corrupted	Non Volatile ram has a long life (10 year) back up battery, either the battery is near end of life or the memory has been corrupted.	Contact Liebert Global Services.
Non Volatile Ram U88 Failed	Non Volatile ram back up battery has reached end of life or the Main control board memory has had a failure.	Contact Liebert Global Services.

Table 5 Alarm Messages (continued)

Alarm Message	Meaning	Corrective Action
Output Overload	The units total output power (the sum of all three phases) has exceeded the overload capacity of the unit. The load will be automatically transferred to bypass (if available).	Determine cause of the overload and reduce the load.
Output Undervoltage Output Overvoltage Overload Phase A Overload Phase B Overload Phase C	UPS output voltage or current is not within the acceptable range. The load has been automatically transferred to bypass (if available). An automatic retransfer will be attempted when the output voltage and current are within tolerance.	Contact Liebert Global Services if the UPS is not able to correct any one of these conditions.
PFC Bus Voltage High PFC Bus Voltage Low PFC Hardware Shutdown	The inverter bus voltage is either high or low or exceeded acceptable limits. The unit will transfer to bypass.	Contact Liebert Global Services.
Site Wiring Error	Warning Alarm: The power conductors are not wired to the UPS input in the desired sequence.	Disconnect power from the UPS input and correct the wiring. Wiring should be verified or corrected by a qualified electrician.
System shutdown impending due to over-temperature	The input filter may be clogged or 1 or more cooling fans may have failed and the internal temperatures are approaching the automatic shutdown level.	Check input air filter. Reduce the system load as much as possible. Contact Liebert Global Services.
System shutdown due to internal over-temperature	The UPS system has shut down and transferred to Bypass as a result of a clogged input filter or failure of 1 or more fans.	Contact Liebert Global Services.
Temporary Overload	The output waveform is distorted. If available, the UPS will transfer to bypass until the waveform distortion is corrected.	Normally the condition will correct itself. If the unit has not corrected this condition within 30 minutes, contact Liebert Global Services.
UPS Overtemp	System shutdown impending due to over-temperature. This is a two-stage alarm. The same message will occur if the system has reached over-temp and has transferred to bypass as a result of the over-temp condition. Other alarms will signal the transfer to bypass.	An over-temperature condition is present in the UPS cabinet. The UPS will automatically transfer to bypass if the over-temperature continues. Determine the cause of the condition and correct it if possible. Check for restricted air flow or fan failure.
UPS Shutdown	The UPS has detected a fault and has shut down, resulting in loss of power to the critical load.	Review and record alarm messages. Contact Liebert Global Services.

Liebert Global Services 1-800-543-2378

4.0 FEATURES & OPTIONS

4.1 Introduction

The UPStation[®] S3 offers a number of features and options that are standard or can be optionally installed in the UPStation S3. Some options are a part of the basic design of the UPStation S3 and must be installed in the factory. Other options and features are field installable and can be installed by Liebert Global Services once the equipment is on-site, or at a later date. If your S3 is delivered with options installed, or if options are ordered for field installation you will receive the UPStation S3 Options User's Manual, document SL-24932. This document contains detailed instructions for the installation and operation of all options.

The UPStation S3 cabinet contains an option slot area behind the front panel and behind the LCD display/Control Board. Features and Options located in this area should only be installed by Liebert Global Services personnel. The UPStation S3 has 5 Option Slots available that can support combinations of the following options. Some limitations exist, so contact a Sales Representative or factory if you wish to install a large selection of options. Features and Options available for the UPStation S3 UPS include:

4.2 RS-232 Communication Feature

The UPStation S3 comes standard with an RS-232 communication port. All information and functions accessible through the control panel are also accessible by a terminal, host computer, or modem (optional) through the RS-232 port. A terminal or computer can be connected to the RS-232 port directly or through a modem connection. The UPS can dial out to a selected phone number to report alarm conditions or will connect when called from a remote terminal.

The terminal will display a representation of the LCD display screen. The UPS will respond to the left arrow, right arrow, enter, and escape keys on the keyboard just like it would from the UPS control panel. You can remotely view UPS meters and alarm history, change configuration settings, and activate remote start and stop.

The DB25 connector located on the upper right inner bulkhead, behind the control board, also provides the following normally open (NO) contacts:

- UPS output available
- Battery discharging
- Low battery reserve
- Bypass active

Terminal Operation

Connect an ANSI terminal (or a computer with a communications program) to the UPS directly or through a modem (optional) connection. Refer to **Figure 27** for connection details.

Set up the computer terminal as follows:

- Baud rate: 2400
- Data bits: 8
- Stop bits: 1
- Parity: none
- Full duplex

The RS-232 interface can operate in the terminal mode that shows the LCD display on the screen, or the ESP mode that is used only by qualified service personnel. To use the terminal mode, just press the space bar. The contents of the LCD display will appear on the screen and you can then use the left arrow, right arrow, enter, and escape keys on the terminal, just as if they were the keypad on the UPS. If using Windows 3.1 you may have to use the < > keys for right and left arrow. If the LCD display does not appear, the RS-232 channel could be in the ESP mode. Verify that a modem connection has been made (if required) then type EXIT. This will return the RS-232 to the terminal mode.

The UPS will respond to requests such as viewing UPS meters or alarm history. Some configuration selections (other than voltage or frequency) can be changed while the unit is operating. You can use the configuration screens UPS ON(1)/OFF(0) to remotely turn the UPS On or Off.

Cables

To assemble a customer-supplied cable, refer to the following instructions and **Figure 27**.

- For a modem cable make connections to pins 2, 3, 7, 8, and 20. Pin 2 on one end should be connected to pin 3 on the other end (this applies to two wires). All other connections are straight through.
- For a terminal cable (direct connection, no modem) make connections to pins 2, 3, and 7. All connections are straight through.

4.3 Factory Installed Options

(Factory installed options do not require an option slot.)

- Dual Input
- 3% Input Current THD
- Isolated Neutral
- Maintenance Bypass
- Output Distribution Panel Board
- Battery Cabinets.

4.3.1 Dual Input

The dual input option provides an additional set of terminal blocks and the appropriate internal connections to allow the bypass source to be supplied from a different source other than the UPS source. Dual input or an optional input transformer is required if the input voltage does not match the output voltage. For example, if the input to the UPS is 480V and the output to the load is 208V, the bypass line must be supplied with a 208V source by connecting the bypass via the dual input option, or by using an optional input transformer.

4.3.2 3% Input Current THD

This option is a basic part of the UPStation S3 design. It must be factory installed and may not be added in the field.

The enhanced THD (total harmonic distortion) performance is achieved by adding dynamic power factor correction circuitry to the UPStation S3.

4.3.3 Isolated Neutral

In the standard unit configuration the neutral passes through the unit from the input utility to the load. With the addition of this option, neutral is electrically isolated from input to output while the unit is in its normal UPS mode. Only in bypass is the utility neutral connected directly to the output neutral. This option is a basic part of the UPStation S3 design. It must be factory installed and may not be added in the field.

4.3.4 Transformer Cabinet

Auto-transformers or isolation transformers are available to provide step-down and/or step-up as needed for the UPS to operate at nominal voltages from 380V up to 600V. For example, an input transformer can be used to step-down input voltage so the UPS can provide 208V output when only 380V to 600V input is available. A 12-inch wide cabinet attaches to the UPS and contains one or two autotransformers, as required. Each transformer is protected by a circuit breaker mounted in the cabinet and is wired by the factory before shipment.

480 Volt sources with 3 hots and a ground (no neutral) require the isolation transformer option to provide the system neutral. Five-wire source voltages (3 hot, neutral, ground) can use the auto transformer version.

4.3.5 Output Distribution Panel

This factory installed option adds a 42-pole Panelboard to the right hand side of the UPStation S3 cabinet. The Panelboard is mounted within the frame of the S3 cabinet and adds no additional width to the unit. A main circuit breaker is provided with each Panelboard. Power wiring from the UPS to the Panelboard is included with the option and is installed at the factory. Branch circuit breakers and output distribution cables (bottom entry) are field installed by others. Access clearance of three (3) feet is required on the right side of the cabinet. For installation and wiring details refer to **Figure 28**.

4.3.6 Battery Cabinets

A number of different battery cabinet options are available with the UPStation S3. For site planning information refer to **Table 1**. Factory-supplied battery cabinets come already installed with UPStation S3.

4.4 Field Installable Options

Field-installable options, when ordered, come complete with installation and user instructions for the option. (Field installable options which require an option slot are identified with a # in the following text):

- Battery Cabinets
- Communication Options
 - SiteNet[®] 1 Shutdown Interface Kits
 - SiteNet[®] SNMP Network Communication Board (Ethernet or Token Ring or both) (#)
 - Internal Modem (#)
- Programmable Relays, 2 Boards, 8 relays each. (Each relay board, max. 2, requires an option slot) (#)
- 8-channel Input Contact Isolator (#)
- Delayed Battery Recharge (#)
- DC Ground Fault (#)
- Remote Alarm Panel (Also requires one programmable relay option, total of one slot) (#)
- Floor Anchors
- Optional Power Supply (#).

Contact your Liebert UPS supplier for availability and ordering information.

This section provides information for some UPS features and options. Where necessary, the option kits will include additional instructions.

4.4.1 External Battery Cabinets

The UPStation S3 has available a selection of battery cabinets which come factory installed. The UPStation S3 can also be ordered without a battery cabinet attached. Other stand-alone Liebert battery cabinets may be supplied or battery cabinets supplied by others can be utilized. The selection of proper batteries, cabinets, circuit breakers and connections is extremely important for the proper operation of your UPS. Do not attempt to install external batteries without checking with a Liebert Sales Representative or factory for proper battery sizing. Do not attempt to start up a system with an external battery without Liebert Global Services checking the system for proper connection and installation.

Integral UPStation S3 batteries come equipped with a temperature sensor for use by the systems temperature compensating charging program. Remotely located batteries do not have this sensor installed or attached. In this case the temperature compensation is disabled and the UPS will charge the battery as if it were at an ambient temperature of 25 degrees C. If your prevailing ambient temperature is significantly different that this temperature, contact Liebert Global Services, and they can adjust your temperature compensated charge rate.

4.4.2 Communication Options

The RS-232 Interface is built into every UPStation S3. Other communication interfaces are provided by optional printed circuit boards that are installed in the option slot area of the S3 cabinet. The RS-232 option terminates in a DB25 connector that supports all available communication modes. See **Figure 27**.

SiteNet[®] 1 Shutdown Interface Kits

Each option kit includes a 15-foot communication cable with connectors, necessary software for computer interface to the UPS, and separate instructions for installation and operation. A power failure will initiate a pre-programmed timer. Then the software performs an automatic unattended orderly shutdown. If the UPS reaches a low battery condition, the software overrides the timer and performs an orderly shutdown. The software runs as a background task on the computer while monitoring the UPS.

SiteNet[®] SNMP (Simple Network Management Protocol)

This option includes a separate interface board and software required to communicate UPS performance to a network management system.

Internal Modem

1. UPS will dial out and notify either a customer terminal or a pocket pager when the load is in danger (i.e., bypass, on battery, etc.).

When calling a terminal:

- UPS will display a list of alarms present on the remote terminal screen.
- Customer can program a site ID string that will be displayed on the remote terminal in addition.
- Customer can press a key on the terminal before or after the alarms are displayed to enter remote panel mode.

When calling a pager:

- Customer can program both the pager telephone number and up to 16 digits that will be transmitted to the pager when the UPS dials out.
 - Customer has the option to have the UPS issue an alarm code to the pager that identifies the class of event occurring (i.e., low battery, on battery, on bypass, load shutdown, etc.). This code can be issued in lieu of OR in addition to a user programmable string of up to 15 digits.
2. The UPS supports dialing up to 2 telephone numbers, which can be any combination of pager or modem. User can select whether to:
 - Always call both numbers.
 - Only call the second number if calling the first number fails.
 - Never call the second number.
 3. The UPS can automatically answer incoming calls from a remote terminal and enter remote panel mode.
 4. The user chooses for the UPS to:
 - Never accept incoming or make outgoing calls.
 - Only make outgoing calls.
 - Only accept incoming calls.
 - Accept incoming AND make outgoing calls.

4.4.3 Programmable Relays

The programmable relay board contains 8 double-pole, double-throw relays that can be connected to a variety of customer outputs. The relays can be individually programmed to trip based on a selection of a number of UPS events. Each relay can be programmed to trip based on any one alarm or any combination of alarms from the available list. Any alarm can also be programmed to trip multiple relays.

Typical applications are AS/400 alarms, Guard Shack, Facilities and/or Manager alarms and an unlimited list of other actions which can be initiated based on data from the UPS.

Up to two alarm boards (16 total relays) may be installed in an UPStation S3. Each alarm board requires an option slot. Installation of the option is by Liebert Global Services. Signal wiring between the Programmable Relay option board and customer output devices must be field-installed by qualified personnel. Installation information is included with the option.

4.4.4 Input Contact Isolator

The Input Contact Isolator option is an 8-channel input board that supports eight customer-supplied, non-powered, normally-open contacts. The Input Contact Isolator comes with a factory-installed Power Supply.

When a contact closes, one of the following actions occurs according to how you have configured the contacts. Input Contacts can be configured to cause the UPS to:

- Display Warning messages only
- Display Warning messages and initiate dial out call if Modem Option is installed.
- Inhibit battery charge if the load is greater than 0%
- Inhibit battery charge if the load is greater than 25%
- Inhibit battery charge if the load is greater than 50%
- Inhibit battery charge if the load is greater than 75%
- Display ground fault on DC bus message

The User can program the name of the input alarm through the LCD. This option requires 1 option slot.

4.4.5 Delayed Battery Recharge

The Delayed Battery Recharge option is used in conjunction with an engine generator set. When signaled that the power source has switched from utility to engine generator, this option will delay the UPS battery recharge until the UPS is returned to utility source power. This will minimize the load on the engine generator during the utility outage. This feature requires the installation of the Input Contact Isolator Option.

4.4.6 Optional DC Ground Fault Alarm

The DC Ground Fault Detector monitors current through the UPStation S3 battery cables. When a ground fault current is detected from any battery positive (+) or negative (-) terminal to ground, a relay contact is closed. The relay contact information is relayed to the Input Contact Isolator and the ground fault message is displayed on the UPS screen.

The DC Ground Fault Detector requires an Input Contact Isolator with a contact assigned as "Display Ground Fault Message." A +24V DC power supply is included on the Input Contact Isolator to power the DC Ground Fault Detector. The AC output critical power from the UPS supplies input power to the +24V DC power supply.

This option requires an Option slot.

4.4.7 Optional Remote Status Panel

The Remote Status Panel includes:

- Load on UPS Indicator (Green LED)
- Battery Discharge Alarm (Red LED)
- Low Battery Reserve Alarm (Red LED)
- Load on Bypass Alarm (Red LED)
- UPS Alarm Condition (Red LED)
- New Alarm Condition (Red LED)
- Audible Alarm
- Lamp Test/Reset Push-button
- Audio Reset Push-button.

The panel is provided in a NEMA Type 1 enclosure suitable for wall mounting. Interface of the panel to the UPS is through connection of control wiring between terminal strips in the UPS cabinet (Programmable Relay Board) and Remote Status Panel.

You must have installed a Programmable Relay Option and an Optional Power Supply Board to install the Remote Status Panel. The Remote Status Panel takes five positions on the Programmable Relay Board. Check your total option list as the Optional Power Supply Board may be supplied for or with other options.

4.4.8 Floor Anchors

Floor anchors provide a mechanical interconnection between the UPStation S3 cabinet frame and the suitable stable floor. If properly installed, the floor anchors are designed to meet Seismic Zone 4 anchoring requirements. Floor anchors are to be installed by trained and licensed contractors in accordance with local and national code requirements.

4.4.9 Optional Power Supply

Certain combinations of Options require the addition of an optional power supply. The Optional Power Supply takes one slot in the Option Tray. Options which require the optional power supply indicate that in the order information and in the documentation included here. If you are installing multiple options, you need to review the requirements with your sales person and Liebert Application Engineering.

Figure 27 RS-232 Connections

NOTE

Connections not to exceed NEC Class 2.

RS-232 Connector

PIN	FUNCTION
1	Not Used
2	R&D
3	T&D
4	Not Used
5	Not Used
6	Not Used
7	Signal Ground
8	Data Carrier Detect (DCD)
9	Not Used
10	Not Used
11	Not Used
12	Not Used
13	Not Used
14	Not Used
15	Not Used
16	Not Used
17	Not Used
18	Not Used
19	Not Used
20	Data Terminal Ready
21	Not Used
22	Ring Indicator (RI)
23	Not Used
24	Not Used
25	Not Used

LAN Connector

PIN	FUNCTION
1	Not Used
2	R&D
3	T&D
4	Not Used
5	Not Used
6	Not Used
7	Signal Ground
8	Not Used
9	Common - Low Battery
10	Low Battery NC
11	Low Battery NO
12	Shutdown AL
13	Power Fail AH
14	Not Used
15	On UPS NO
16	On Battery NO
17	On Battery / On UPS Common
18	On Battery NC
19	Shutdown AL
20	Not Used
21	Low Battery AH
22	Not Used
23	Not Used
24	On Bypass NC
25	Altos - Tri-level

Note: NC/NO - State of contacts when signal is not present.

Note: NC/NO - State of contacts when signal is not present.

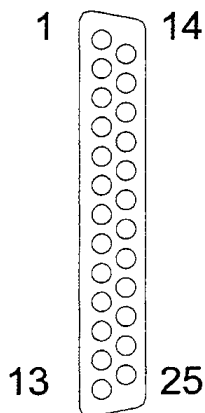

DB25 (Female)

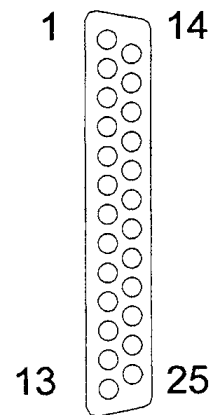

DB25 (Female)

Figure 28 Output Distribution Panel Board

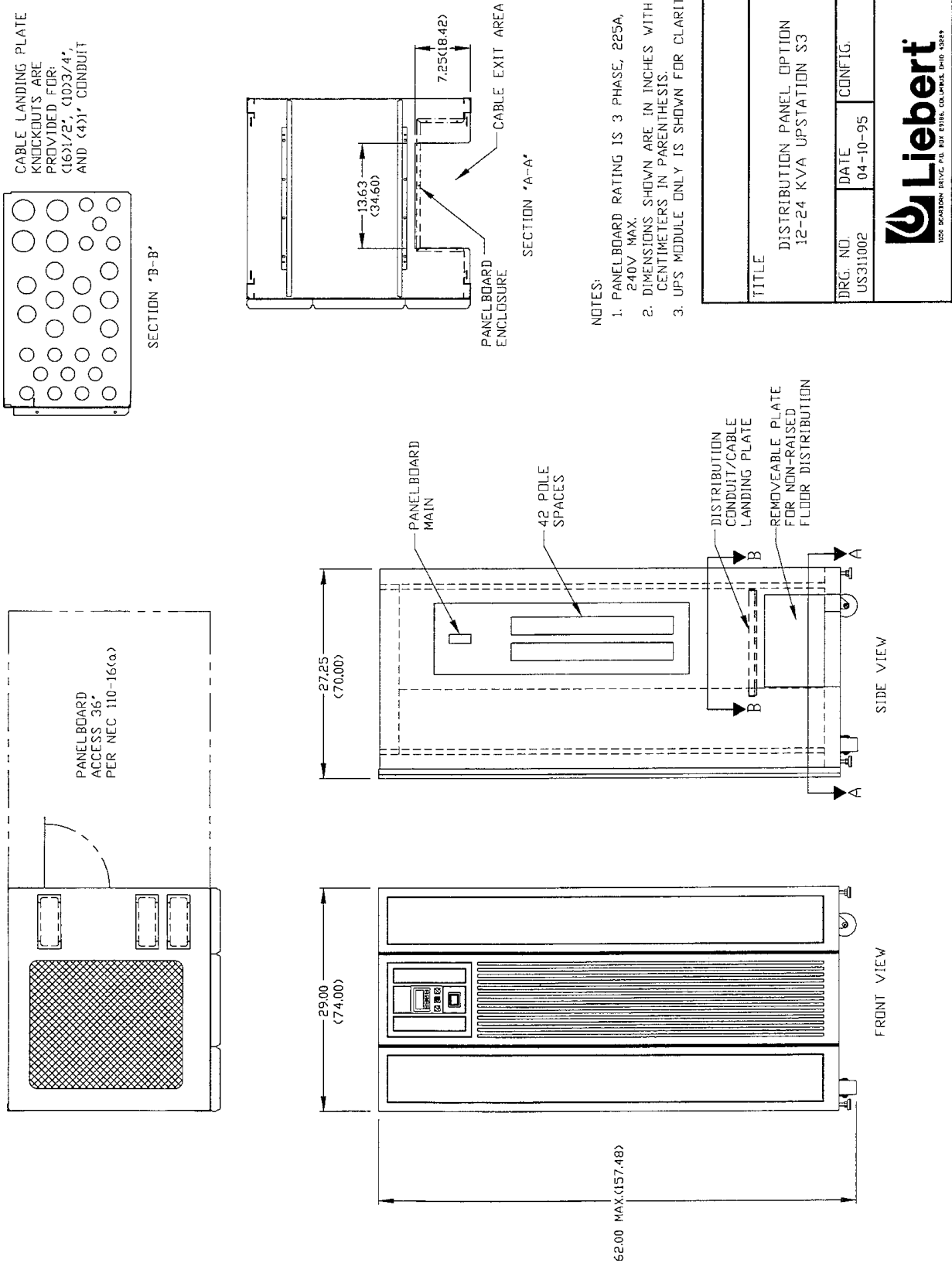

5.0 MAINTENANCE

5.1 Routine Maintenance Requirements

The UPStation® S3 UPS is designed to provide years of trouble-free operation.

System reliability will be enhanced if the UPS is kept clean and cool. Occasionally vacuum dust deposits from around the ventilation grilles and wipe the UPS with a dry cloth.

Periodically check the UPStation S3 UPS operation by switching off the utility power supply and observe the On Battery message. This should be done when only non-critical loads are connected to the unit.

5.1.1 Air Filter Maintenance

Open front door for access to the replaceable air filter. The air filter is located in a customer accessible tray in the bottom front of the unit. To remove the filter, slide the filter element out of the tray. Check the filter after the first 3 months of operation, then every 6 months (more often if required by the environment). Dispose and replace the filter when dirty. Liebert Global Services can advise and supply the proper filter replacement.

The UPS has an automatic filter replacement warning. Every three weeks the system will cause a warning "Replace Air Filter". Replace the air filter and clear the warning screen by pressing the left and right arrow keys simultaneously. After 30 seconds the warning screen will clear. The time between filter warnings is set at the factory for 3 months. To change the time interval contact Liebert Global Services at **1-800-543-2378**.

5.1.2 Cleaning

Clean UPS with only a dry cloth. Do not use liquids or aerosol cleaning fluids.

5.1.3 Troubleshooting

Troubleshooting should only be performed by a trained engineer authorized by Liebert Global Services. If your UPS develops a fault, refer to **3.7 - User Response to UPS Alarms**. If you cannot resolve the problem, consult Liebert Global Services immediately at **1-800-543-2378**. Do not continue to use the UPS if it is not performing to specification.

Call Liebert Global Services to replace fuses so that the cause of failure can be determined.



WARNING

LETHAL VOLTAGES MAY BE PRESENT WITHIN THIS UNIT EVEN WHEN IT IS APPARENTLY NOT OPERATING. OBSERVE ALL CAUTIONS AND WARNINGS IN THIS MANUAL. FAILURE TO DO SO COULD RESULT IN SERIOUS INJURY OR DEATH.

REFER UNIT TO QUALIFIED SERVICE PERSONNEL IF MAINTENANCE IS REQUIRED. DO NOT WORK ON THIS EQUIPMENT UNLESS YOU ARE FULLY QUALIFIED TO DO SO. NEVER WORK ALONE.

5.2 Battery Maintenance

The batteries that provide standby power for the UPStation S3 UPS are inside the attached or stand-alone UPS battery cabinet. The standard batteries supplied with the system are valve-regulated batteries. During normal operating conditions the batteries are kept charged. The battery is automatically tested by the UPS control circuit. If there is a battery charger problem or if the battery fails a test, an alarm message will be displayed.

Call Liebert Global Services at **1-800-543-2378** if battery maintenance or replacement is required.

Battery Safety Precautions

Servicing of batteries should be performed or supervised by personnel knowledgeable of batteries and the required precautions. Keep unauthorized personnel away from batteries.



WARNING

DO NOT DISPOSE OF BATTERY OR BATTERIES IN A FIRE. THE BATTERY MAY EXPLODE.

DO NOT OPEN OR MUTILATE THE BATTERY OR BATTERIES. RELEASED ELECTROLYTE IS HARMFUL TO THE SKIN AND EYES. IT MAY BE TOXIC.

A BATTERY CAN PRESENT A RISK OF ELECTRICAL SHOCK AND HIGH SHORT-CIRCUIT CURRENT. THE FOLLOWING PRECAUTIONS SHOULD BE OBSERVED WHEN WORKING ON BATTERIES:

- 1. REMOVE WATCHES, RINGS, OR OTHER METAL OBJECTS.**
- 2. USE TOOLS WITH INSULATED HANDLES.**
- 3. WEAR RUBBER GLOVES AND BOOTS.**
- 4. DO NOT LAY TOOLS OR METAL PARTS ON TOP OF BATTERIES.**
- 5. DISCONNECT CHARGING SOURCE PRIOR TO CONNECTING OR DISCONNECTING BATTERY TERMINALS (REMOVE BATTERY FUSES).**
- 6. DETERMINE IF BATTERY IS INADVERTENTLY GROUNDED. IF INADVERTENTLY GROUNDED, REMOVE SOURCE OF GROUND. CONTACT WITH ANY PART OF A GROUNDED BATTERY CAN RESULT IN ELECTRICAL SHOCK. THE LIKELIHOOD OF SUCH SHOCK WILL BE REDUCED IF SUCH GROUNDS ARE REMOVED DURING INSTALLATION AND MAINTENANCE.**

THE BATTERY ELECTROLYTE IS A DILUTE SULFURIC ACID THAT IS HARMFUL TO THE SKIN AND EYES. IT IS ELECTRICALLY CONDUCTIVE AND CORROSIVE. THE FOLLOWING PROCEDURES SHOULD BE OBSERVED:

- 1. WEAR FULL EYE PROTECTION AND PROTECTIVE CLOTHING.**
- 2. IF ELECTROLYTE CONTACTS THE SKIN, WASH IT OFF IMMEDIATELY WITH WATER.**
- 3. IF ELECTROLYTE CONTACTS THE EYES, FLUSH THOROUGHLY AND IMMEDIATELY WITH WATER. SEEK MEDICAL ATTENTION.**
- 4. SPILLED ELECTROLYTE SHOULD BE WASHED DOWN WITH A SUITABLE ACID NEUTRALIZING AGENT. A COMMON PRACTICE IS TO USE A SOLUTION OF APPROXIMATELY ONE POUND (500 GRAMS) BICARBONATE OF SODA TO APPROXIMATELY ONE GALLON (4 LITERS) OF WATER. THE BICARBONATE OF SODA SOLUTION SHOULD BE ADDED UNTIL THE EVIDENCE OF REACTION (FOAMING) HAS CEASED. THE RESULTING LIQUID SHOULD BE FLUSHED WITH WATER AND THE AREA DRIED.**

LEAD-ACID BATTERIES CAN PRESENT A RISK OF FIRE BECAUSE THEY GENERATE HYDROGEN GAS. THE FOLLOWING PROCEDURES SHOULD BE FOLLOWED:

- 1. DO NOT SMOKE WHEN NEAR BATTERIES.**
- 2. DO NOT CAUSE FLAME OR SPARK IN BATTERY AREA.**
- 3. DISCHARGE STATIC ELECTRICITY FROM BODY BEFORE TOUCHING BATTERIES BY FIRST TOUCHING A GROUNDED METAL SURFACE.**

6.0 SPECIFICATIONS

6.1 System

Safety Agencies:	UL 1778 listed CSA 22.2, No. 107.1 certified
Audible Noise:	57 dBA at one meter
Transient/Surge Protection:	Per IEEE 587/ANSI C62.41 Categories A & B

6.2 Physical Characteristics

Operating Environment:	0° to 40°C 25° ±5°C for batteries
Relative Humidity:	0 to 95% relative humidity (non-condensing)
Altitude:	6600 feet (2,000 meters)

Refer to **Table 1 - Site Planning Data** for dimensions and weights.

6.3 AC Input

Voltage Range:	170 to 264 VAC (See Table 1 - Site Planning Data)
Voltage Configuration and Connection:	Three phase input, Wye configuration with 3 phases, ground and neutral. Dual input if input and output voltages are not the same.
Frequency Range:	45 Hz to 65 Hz
Input Current THD:	25% - 30% THD maximum at full load 3% THD option available
Power Factor:	.95 Standard .99 with 3% THD Option

6.4 AC Output

Voltage Regulation:	±1% for balanced loads ±1.5% for 100% unbalanced loads
Voltage Distortion:	Maximum 2% THD for linear loads at 208 VAC Maximum 3.5% THD for full non-linear loads at 208 VAC
Transient Response:	±1% for 100% step load; recovery to within 1% in one cycle
Frequency:	50 Hz or 60 Hz
Frequency Slew Rate:	1 Hz/sec (user-selectable 0.1 to 3 Hz/sec)
Frequency Sync Range:	±1 Hz (user-selectable ±0.1 Hz to 5 Hz)
Load Crest Factor:	3:1
Overload:	125% for 10 minutes, 150% for 10 seconds
Unbalanced Load Capability:	Up to 100% of the individual phase rating

6.5 Battery

Type:	Standard: Valve-regulated, lead acid Optional: Flame retardant, valve-regulated, lead-acid (rated for computer room operation)
Recharge Rate:	10 times discharge duration to 95% when "turbo" mode is selected
Battery Run-Time:	Varies with battery cabinet selection
Battery Voltage:	Nominal: 240 VDC



UPStation[®] S3

Three Phase

12 kVA to 24 kVA; 50 and 60 Hz

Technical Support

U.S.A.	1-800-222-5877
Outside the U.S.A.	614-841-6755
U.K.	+44 (0) 1793 553355
France	+33 1 4 87 51 52
Germany	+49 89 99 19 220
Italy	+39 2 98250 1
Netherlands	+00 31 475 503333
E-mail	upstech@liebert.com
Web site	http://www.liebert.com
Worldwide FAX tech support	614-841-5471

The Company Behind The Products

With more than 500,000 installations around the globe, Liebert is the world leader in computer protection systems. Since its founding in 1965, Liebert has developed a complete range of support and protection systems for sensitive electronics:

- Environmental systems: close-control air conditioning from 1.5 to 60 tons.
- Power conditioning and UPS with power ranges from 250 VA to more than 1000 kVA.
- Integrated systems that provide both environmental and power protection in a single, flexible package.
- Monitoring and control — on-site or remote — from systems of any size or location

Service and support, through more than 100 service centers around the world, and a 24-hour Customer Response Center.

While every precaution has been taken to ensure accuracy and completeness of this literature, Liebert Corporation assumes no responsibility, and disclaims all liability for damages resulting from use of this information or for any errors or omissions.

© 1998 Liebert Corporation. All rights reserved throughout the world. Specifications subject to change without notice.

® Liebert and the Liebert logo are registered trademarks of Liebert Corporation. All names referred to are trademarks or registered trademarks of their respective owners.

Printed in U.S.A.

SL-24930