

DURABRAND

CASSETTE PLAYER

MODEL 820M

Operating Instructions

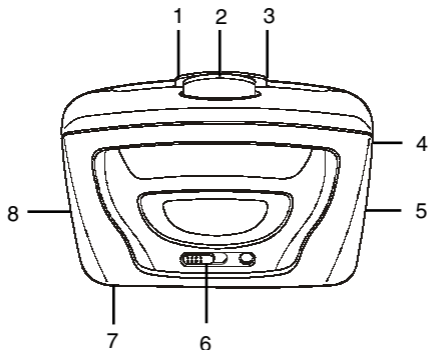

1. STOP BUTTON
2. PLAY BUTTON
3. FAST FORWARD BUTTON
4. HEADPHONE JACK
5. VOLUME CONTROL
6. BASS BOOST SWITCH
7. BATTERY DOOR (at back)
8. BELT CLIP (at back)

BATTERY INSTALLATION

Slide the BATTERY DOOR in the direction shown by the arrow to open the door and insert 2 "AA" batteries, taking care not to reverse the positive and negative polarities.



Alkaline batteries are recommended and will normally provide more playing time.

- Do not mix old and new batteries.
- Do not mix alkaline, standard (carbon-zinc) or rechargeable (nickel-cadmium) batteries.

NOTE:

- Remove the batteries during long periods (about 30 days or more) of nonuse, possible battery leakage and corrosion can damage the set.
- If the sound becomes weak and unclear, the batteries may be weak. Replace both batteries at once.

TO INSERT THE TAPE

1. Open the CASSETTE DOOR by holding the door as shown and gently pulling it to you.
2. Insert the tape into the cassette holder **ON THE DOOR**.
3. Close the CASSETTE DOOR gently till it clicks shut.



CAUTION: Do not pull door too strongly or you may damage the door, treat this set with care and it will last a long time.

TAPE PLAY

1. Check whether or not the tape is tight before it is inserted.

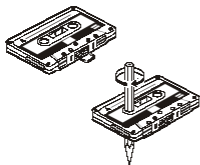

- To keep the tape from tangling, firmly wind the tape before inserting it into the player.
- **Use of a cassette with more than 90 minutes, such as C-120 (120 minutes), is not recommended. The extreme thinness of this tape may damage this set.**

2. Open the CASSETTE DOOR by hand, face the side to be played toward you, and insert the cassette tape. Close the CASSETTE DOOR.
3. Connect the headphones to the jack and adjust the headphone band for proper fit.
4. Press the PLAY button.
5. Adjust the VOLUME to control the sound level you like.
6. To skip portions of the cassette tape, press the FAST FORWARD button.
7. To stop playing the cassette tape, press the STOP button, and the power source is also turned off.

(This set has a built-in auto-stop and the tape mechanism will stop playing and shut off when it reaches the end of the tape.)

8. To hear the other side of tape, flip it over and press PLAY.

TO HEAR THE SAME SONG AGAIN

1. Remove the tape, flip it around to the other side and insert it.
2. Press the FAST FORWARD button for a short time.
3. Remove tape, flip it around to the original side, reinsert and press PLAY.

BASS BOOST SWITCH

This switch enhances the low frequency (bass) sound at low listening levels. To suit your taste, switch the BASS BOOST switch to the right side, the red indicator appears inside the circle.

CLEANING TAPE HEAD

If the sound drops out or excessive noise occurs, clean the magnetic head, capstan and pinch roller with a cotton swab moistened with alcohol.

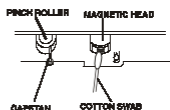

GENERAL SPECIFICATION

Tape function	: Play / Fast Forward / Stop
Speed deviation	: +3% -2%
Frequency response	: 200Hz - 6kHz
Output power (Max)	: More than 20 mW/ch
Power source	: 2 "AA" Alkaline batteries (not included)

LIMITED WARRANTY

We warrant this product to be free from defects in material and workmanship under normal use for a period of 90 days after purchase and we will repair it free of charge or replace it at no charge, should it become defective under this warranty, providing you submit proof of purchase (sales slip) with the set.

During the initial 90 day period after original purchase, we will service or exchange, at no charge, the set that is returned to LENOXX ELECTRONICS CORP. After the initial 90 day period expires, and for a period of 12 months from original purchase, we will repair the unit covering any part(s) that need to be replaced at no charge, but will charge for the cost of labor, return postage paid by LENOXX.

This warranty does not apply to any products which have been subject to misuse, neglect or accident. This warranty does not cover broken headphones or cabinet. UNDER NO CIRCUMSTANCES WILL LENOXX ELECTRONICS CORP. BE LIABLE FOR ANY INCIDENTAL OR CONSEQUENTIAL DAMAGES. Some states do not allow the exclusion or limitation of incidental or consequential damages, so the above limitations or exclusions may not apply to you.

This warranty gives you specific legal rights, and you may also have other rights which vary from state to state. The following charges apply to repairs beyond the warranty period: \$2.00. Be sure to pack carefully and return postage paid insured together with your money order (personal checks will not be accepted) and sales receipt to:

LENOXX ELECTRONICS CORP., 2 GERMAK DRIVE, CARTERET
N.J. 07008

For Customer Service

Dial 1-800-315-5885 (MONDAY - THURSDAY 9:00 AM - 5:00 PM, FRIDAY 9:00 AM - 1:00 PM EST)

or Visit Our Website: <http://www.lenoxx.com>

© 2003 LENOXX ELECTRONICS CORP.

2 GERMAK DRIVE

CARTERET, N.J. 07008

MADE & PRINTED IN CHINA

<http://www.lenoxx.com>

--- 4 ---

IB-820M(B)-WM-E-050703