

# Chromalox®

## *Installation, Operation* and **RENEWAL PARTS IDENTIFICATION**

### SERVICE REFERENCE

DIVISION 4

SECTION DH

SALES  
REFERENCE (Supersedes PF455-2)

PF455-3

161-562766-001

DATE FEBRUARY, 2001

## **Chromalox Electric Airduct Heaters with Fintube Heating Elements**

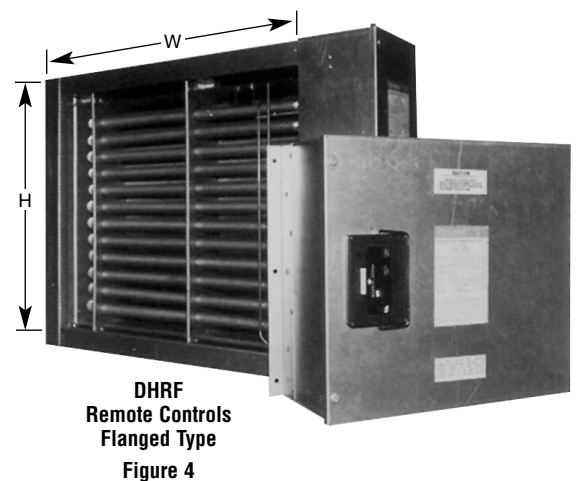
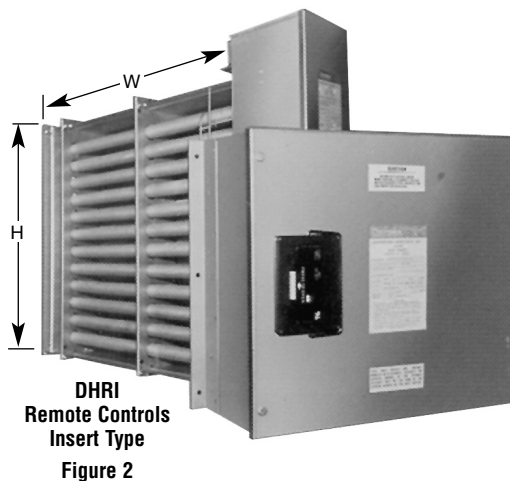
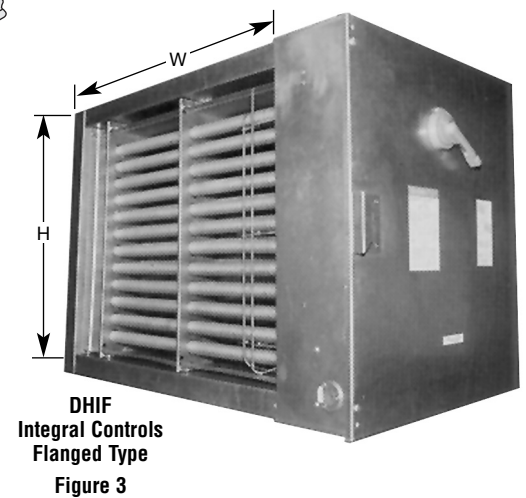
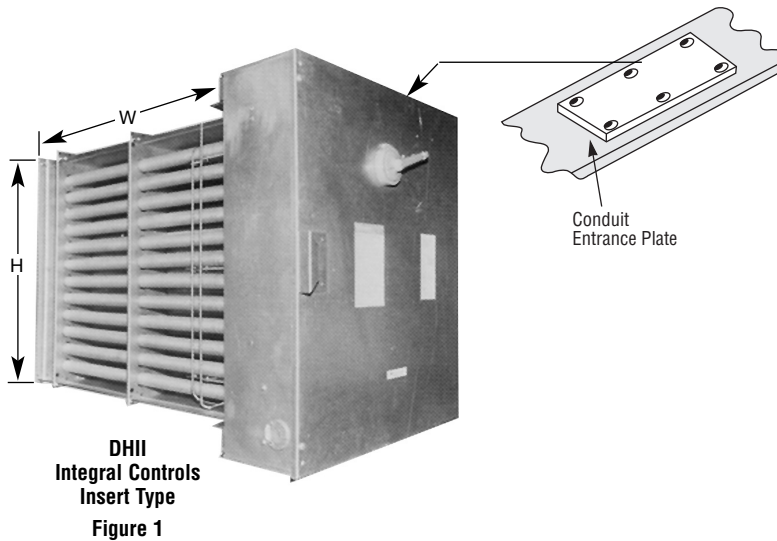

### **GENERAL**

These heaters are designed to be installed in either a horizontal or vertical duct in one of the six positions shown in figure 16. The heater is constructed with individual metal sheath fintube elements mounted to a heavy gauge metal terminal box.

*Due to the various options and materials available, check the nameplate attached to the heater terminal box with the catalog number designation system on page 7 before installing to insure the heater you received conforms to your specification.*

*Please read these directions carefully to insure all limitations are properly observed and all wiring and controls are properly installed and connected.*

**IMPORTANT** — Observe at least one complete heating cycle operation before leaving the installation.

## GENERAL

**Limitations:** Ductwork must be in accordance with one of the following: Standards of the National Fire Protection Association for the installation of Air Conditioning and Ventilating Systems of other than Resident Type (Pamphlet 90A) or Residential Type Warm Air Heating and Air Conditioning Systems (Pamphlet 90B).

**Location:** Chromalox Duct Heaters may be located anywhere in the duct system.

**NOTE:** The minimum distances shown are limitations. Wherever possible, locate as far away from these limits as practical. In any case, this distance with any required airflow correction must be sufficient to accomplish even air flow at a velocity equal to, at least, the minimum stated on the heater nameplate.

1. Installation near heat pump, central air conditioner, filters or humidifier. (Refer to Figure 5).

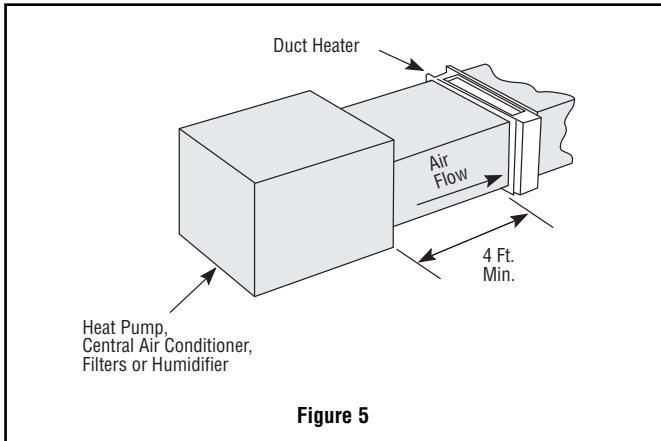

2. Installation near air handler discharge. (Refer to Figure 6).

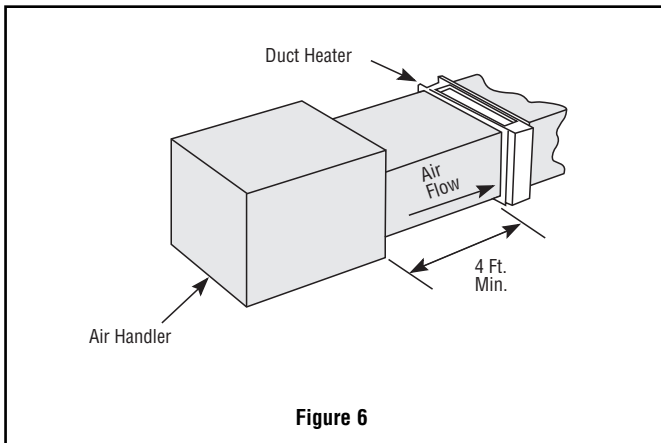

3. Installation in branch duct take-off. (Refer to Figure 7).

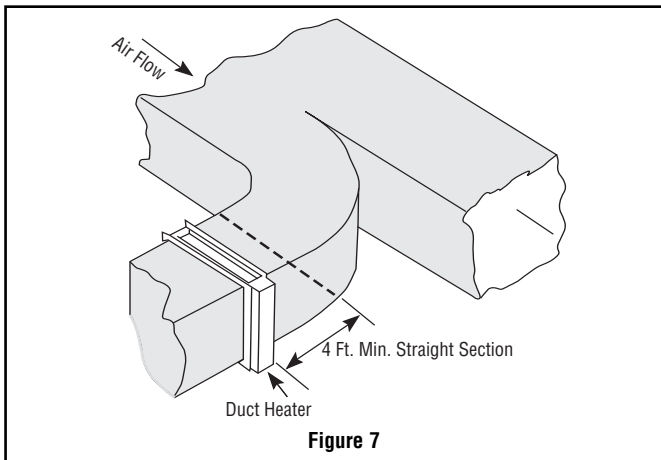

4. Installation near turns. (Refer to Figure 8). If heater must be installed closer than 4 feet from the downstream side of a turn, turning vanes must be installed in the turn. The turning vanes will straighten out the air flow so it will be uniform over the face of the heater.

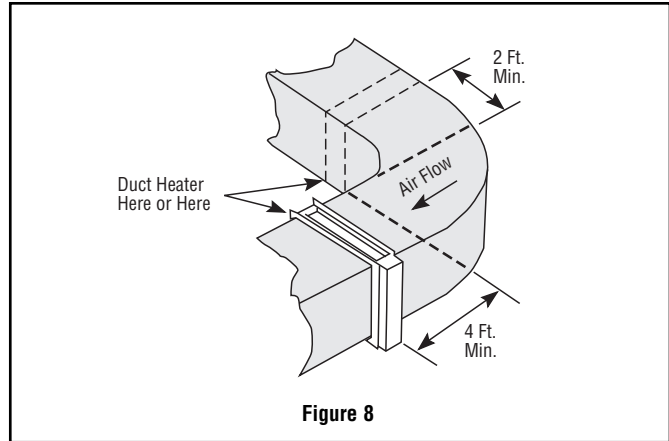

5. Installation with duct transitions in some air distribution systems, the duct heater may be considerably larger than the ductwork and the duct area must be increased by a sheet metal transition. The slope of the transformation piece on the upstream side of the equipment is limited to 30° as indicated in Figure 9. On the leaving side, the slope should not be more than 45°.

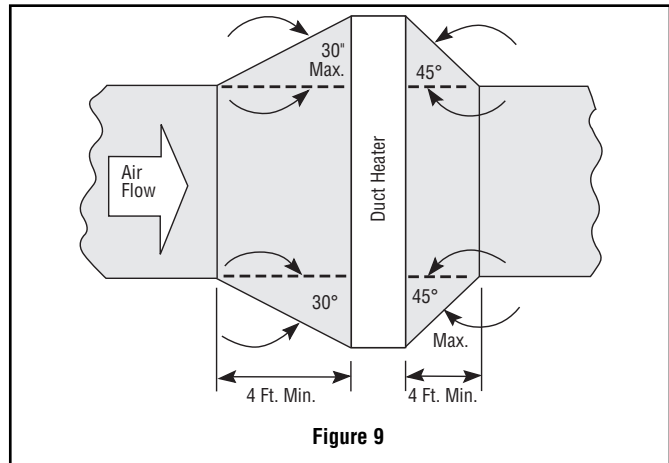

6. Do not insulate control or terminal box. (Refer to Figure 10).

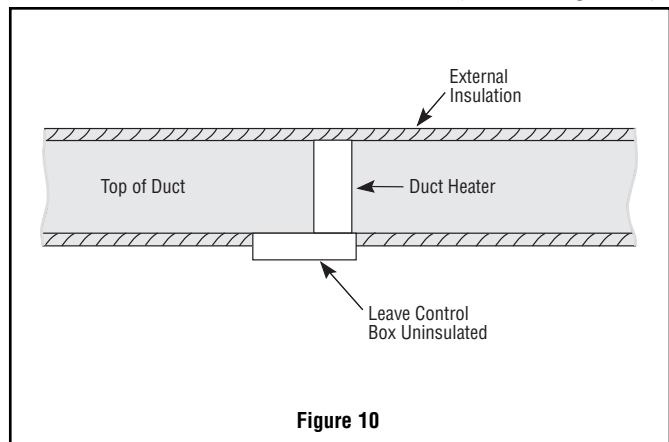

## GENERAL

7. Installation in duct larger than heater. For installation where the duct dimensions exceed the insert type heater dimensions, the area beyond the heater dimensions must be filled with wire mesh, expanded or perforated sheet metal of 50% open area as shown in Figure 11. This will maintain a uniform air velocity across the face of the duct.

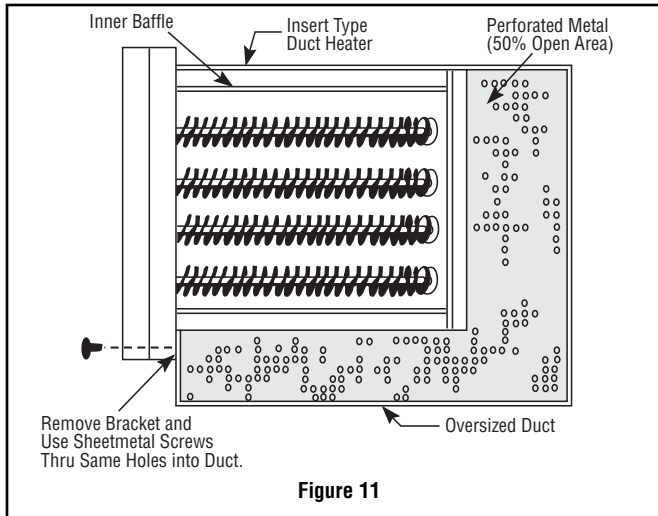

8. Installation with flexible duct. Where a duct heater must be installed near a flexible duct connection, be certain that a 4' minimum distance between the duct heater and the flexible duct connector exists and that the connector is suitable for 195°F temperature. (Refer to Figure 12).
9. Do not install duct heater outdoors. Duct heaters cannot be installed with rooftop equipment where they are exposed to the weather.

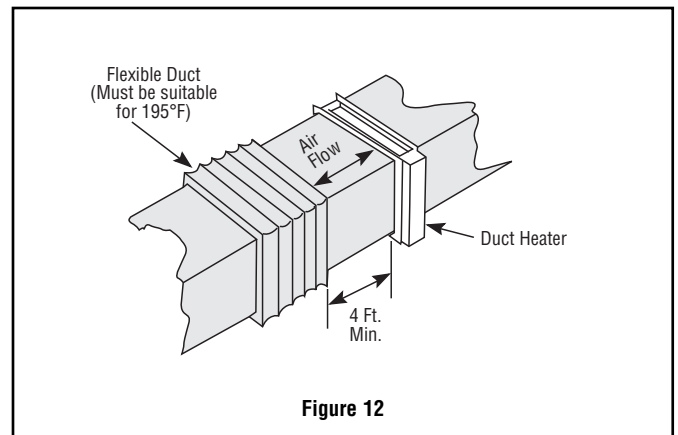

10. Installation with dampers or filters. Maintain at least 4' distance between duct heater and damper, filter frames, or other similar obstructions. (Refer to Figure 13).

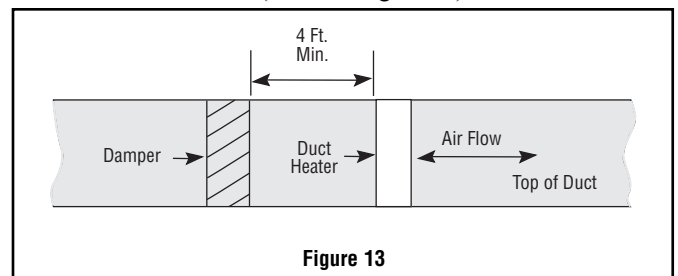

**Clearance:** Zero clearance between duct heater and combustible materials such as wood is permissible. However, adequate clearance must be provided around terminal box for proper ventilation and future service accessibility.

## AIR FLOW

Flow through duct heater must never drop below the minimum air velocity shown on duct heater nameplate. If the air handling system includes filters, they must be cleaned whenever necessary in order to maintain air flow above the minimum, otherwise poor temperature control and discomfort will result.

If air flow is poorly distributed within the duct, deflector vanes must be added to provide correction.

The minimum air velocities shown on the nameplate are not to be considered average readings. Do not add various velocities taken across the face of the duct, find an average value, and compare it to the minimum velocity shown on the heater nameplate.

The minimum air velocity refers to any point along the face of the duct heater when checking duct velocities, no velocity can be below that shown on the heater nameplate (remembering inlet air temperature). Velocities are best checked with an anemometer, taking numerous readings along the horizontal and vertical centerline of the duct heater at the location prior to installation or slightly up stream from the heater after installation. (Refer to Figure 14).

Large ducts will require additional readings taken at locations in addition to the centerline.

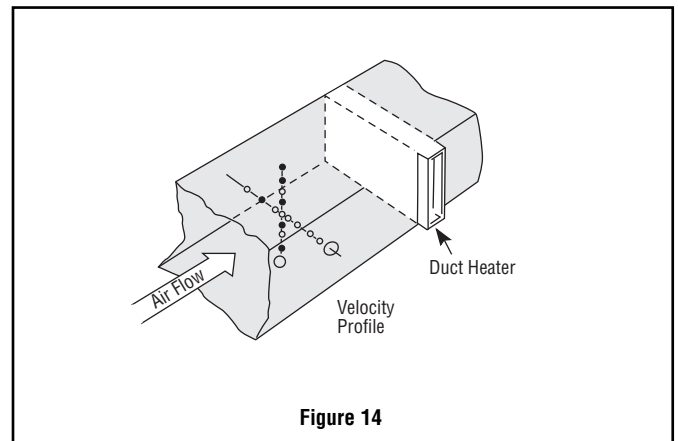

**Incoming Air Temperature:** Incoming air temperature entering the duct heater must not exceed 100°F.

### Example: 500 FT./MIN. Minimum Air Velocity on Heater Nameplate.

Velocity	600	Velocity	200x
Profile	500	Profile	400x
FT./MIN.	700	Profile	800
Velocity	600	Profile	900
Profile	900	FT./MIN.	600
FT./MIN.	700	Profile	700
Velocity	600	Profile	200x
Profile	500	Profile	300x
FT./MIN.	500	Profile	400x
<b>RIGHT:</b>	500 FT./MIN. MINIMUM	<b>WRONG:</b>	$9 \sqrt{4500} = 500$ FT./MIN. AVERAGE
			X - below 500 FT./MIN.

## MOUNTING

**Multiple Duct Heaters:** Up to six duct heaters may be combined into a heating bank as shown in Figure 15. When called for on order, brackets will be furnished for fastening flange type duct heaters together to form a bank. Heater will be coded for proper assembly in the field.

Two to six duct heaters (with flange) may be installed in a horizontal or vertical duct.

Heaters must be mounted in the position designated by arrows on the heater frame. (Refer to Figure 16).

The heater terminal box on vertical duct installations can be located on any side of the duct but for horizontal duct installation the terminal box must be on the side of the duct.

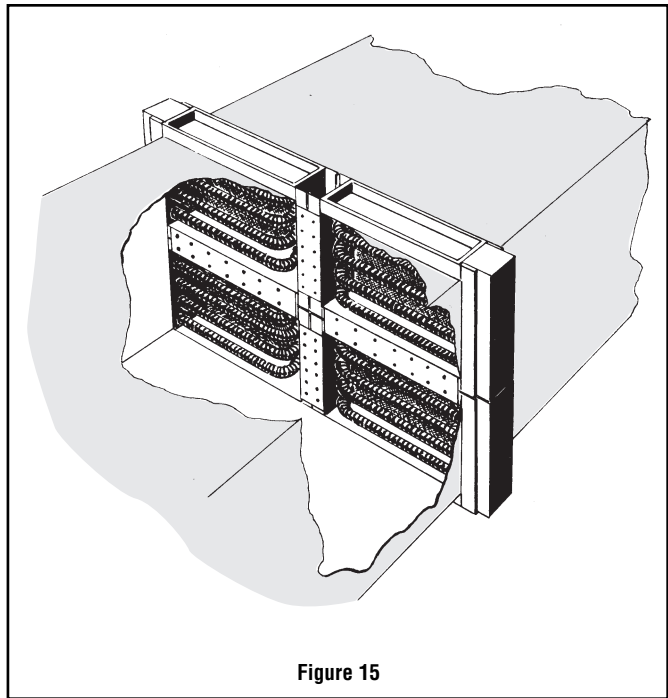

Figure 15

### ⚠ WARNING

***This heater is not intended for use in hazardous atmospheres where flammable vapors, gases, liquids, or other combustible atmospheres are present as defined in the National Electric Code. Failure to comply can result in explosion or fire.***

Figure 16

<p><b>HORIZONTAL DUCT</b> — side terminal box entry for style DHRI &amp; DHRF heaters. Air flow as shown. Install with this arrow up. </p> <p style="text-align: center;">Mounting Position 1</p>	<p><b>HORIZONTAL DUCT</b> — side terminal box entry for style DHRI &amp; DHRF heaters. Air flow as shown. Install with this arrow up. </p> <p style="text-align: center;">Mounting position 2</p>	<p><b>VERTICAL DUCT</b> — side terminal box entry for style DHRI &amp; DHRF heaters. Air flow as shown. Install with this arrow up. </p> <p style="text-align: center;">Mounting Position 3</p>	
<p><b>HORIZONTAL DUCT</b> — Side terminal box entry for style DHII &amp; DHIF heaters. Air flow as shown. Install with this arrow up. </p> <p style="text-align: center;">Mounting Position 4</p>	<p><b>HORIZONTAL DUCT</b> — Side terminal box entry for style DHII &amp; DHIF heaters. Air flow as shown. Install with this arrow up. </p> <p style="text-align: center;">Mounting Position 5</p>	<p><b>VERTICAL DUCT</b> — Side terminal box entry for style DHII &amp; DHIF heaters. Air flow as shown. Install with this arrow up. </p> <p style="text-align: center;">Mounting Position 6</p>	

## MOUNTING

### Mounting Procedure — DHIF

#### (Flanged heaters with control box)

1. At heater location, cut out a section of duct, or a new construction lay out duct work to accommodate dimensions of heater.
2. Form mounting flanges on cut edges of duct as shown in Figure 17. Omit flange in side when terminal box overhangs.
3. Position heater in duct and attach duct lip to heater flanges with sheet metal screws.
4. Attach control box to duct with sheet metal screws through the mounting holes provided inside the control box.

**NOTE:** Where necessary, make provision to support weight of heater. Any part of heater flange may be drilled for attaching hanger straps or duct.

5. Where necessary, joint between duct and heater flange may be sealed with silicone gaskets or silicone sealant.

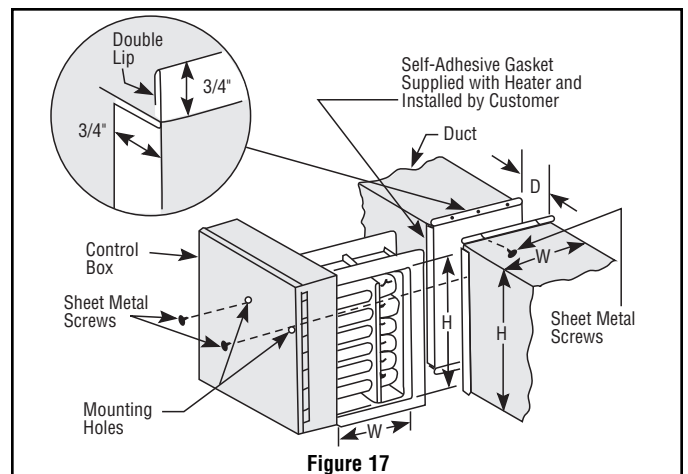

### Mounting Procedure DHII

#### (Insert heaters with control box)

1. Measure dimension "H" of duct heater (Figure 1) and mark the duct with an outline for a rectangular hole with dimensions of D-1½". The D-1½" dimension is to be parallel to the direction of air flow.
2. Increase D-1½" slot to D by forming a ¾" double lip on both sides of the duct opening. (See Figure 18).
3. Slide heater into duct.
4. Attach control box to duct with sheet metal screws through the mounting holes provided inside the control box and through the brackets on the top and bottom of heater.
5. Where necessary, make provision to support weight of heater and terminal box.

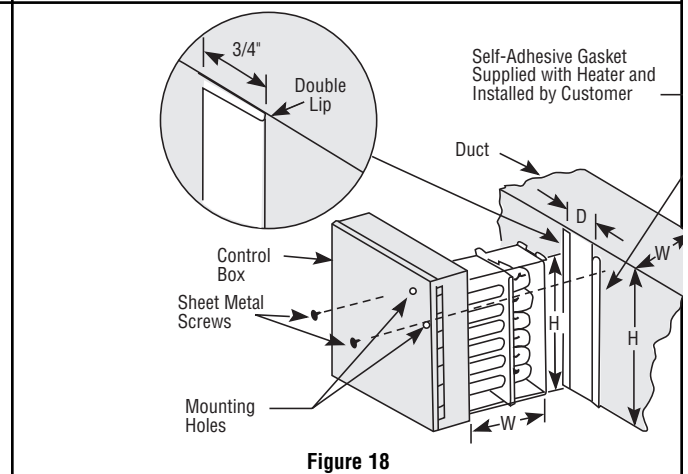

### Mounting Procedure — DHRF

#### (Flanged heaters with compact terminal box)

1. At heater location, cut out a section of duct, or on new construction lay out duct work to accommodate dimensions of heater.
2. Form mounting flanges on cut edges of duct as shown in Figure 19.
3. Position heater in duct and attach duct lip to heater flanges with sheet metal screws.

**NOTE:** Where necessary, make provision to support weight of heater. Any part of heater flange may be drilled for attaching hanger straps or duct.

4. Attach control box to duct with sheet metal screws through the mounting holes provided inside the control box.
5. Where necessary, joint between duct and heater flange may be sealed with silicone gasket or sealant.

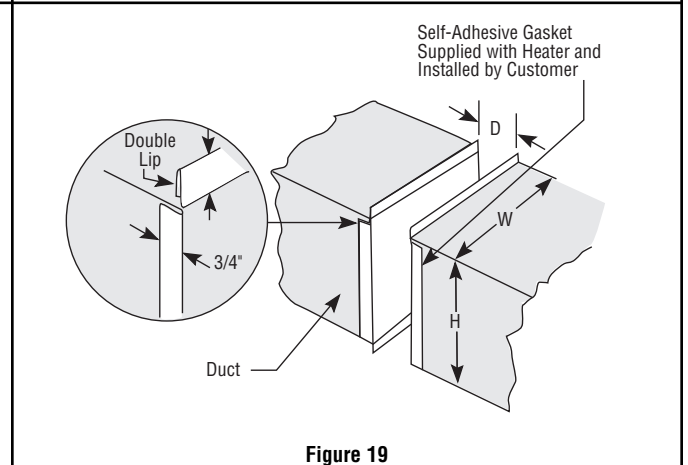

### Mounting Procedure — DHRI

#### (Insert heaters with compact terminal box)

1. Measure dimension "H" of duct heater (Figure 2) and mark the duct with an outline for a rectangular hole with dimensions of D-1½" x "H". The D-1½" dimension is to be parallel to the direction of air flow.
2. Increase D-1½" slot to "D" by forming a ¾" double lip on each side of the duct. (See Figure 19).
3. Slide heater into duct.
4. Attach control box to duct with sheet metal screws through the mounting holes provided inside the control box and through the brackets on the top and bottom of heater.
5. Where necessary, make provision to support weight of heater.

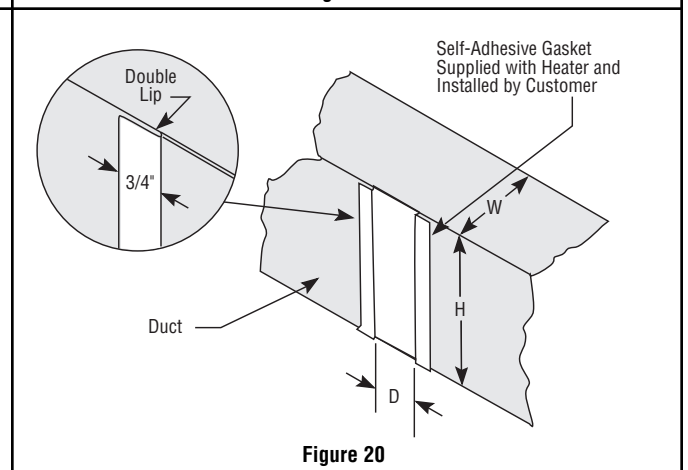

## WIRING

1. Connect heater only to the voltage, frequency and phase specified on the nameplate.
2. All wiring should be done according to local and National Electric Codes.
3. Make supply connections to marked heater terminals using wire suitable for 75°C. (Type RH-RW or equivalent).
4. Conduit attachment to heater:
  - a. Run conduit(s) to conduit entrance plate. (See Figure 1).
  - b. Mark plate where conduit(s) will enter plate.
  - c. Remove screws and plate.
  - d. Punch conduit entrance plate with a hole(s) to accommodate the required conduit(s).
  - e. Reinstall plate and install conduit(s) to plate.

**Fan Interlock.** The fan circuit must be interlocked with the control circuit of the heater. Refer to the wiring diagram in the heater terminal box.

### ⚠ WARNING

**Hazard of electrical shock. Any installation involving electric heaters must be grounded to earth to eliminate shock hazard.**

Volts	Control Ratings			
	Manual Limit Control		Automatic Limit Control	
	Pilot Duty	Non-Inductive Rating	Pilot Duty	Non-Inductive Rating
120	125 VA	3000 Watts	125 VA	3000 Watts
208	125 VA	5200 Watts	125 VA	5200 Watts
240	125 VA	6000 Watts	125 VA	6000 Watts
277	125 VA	6925 Watts	125 VA	6925 Watts

### ⚠ WARNING

**Hazard of severe shock. Disconnect all power to heater before servicing.**

## WIRING DIAGRAM

**The appropriate wiring diagram will be supplied with each heater.**

## RENEWAL PARTS IDENTIFICATION

Typical DHIF Duct Heater

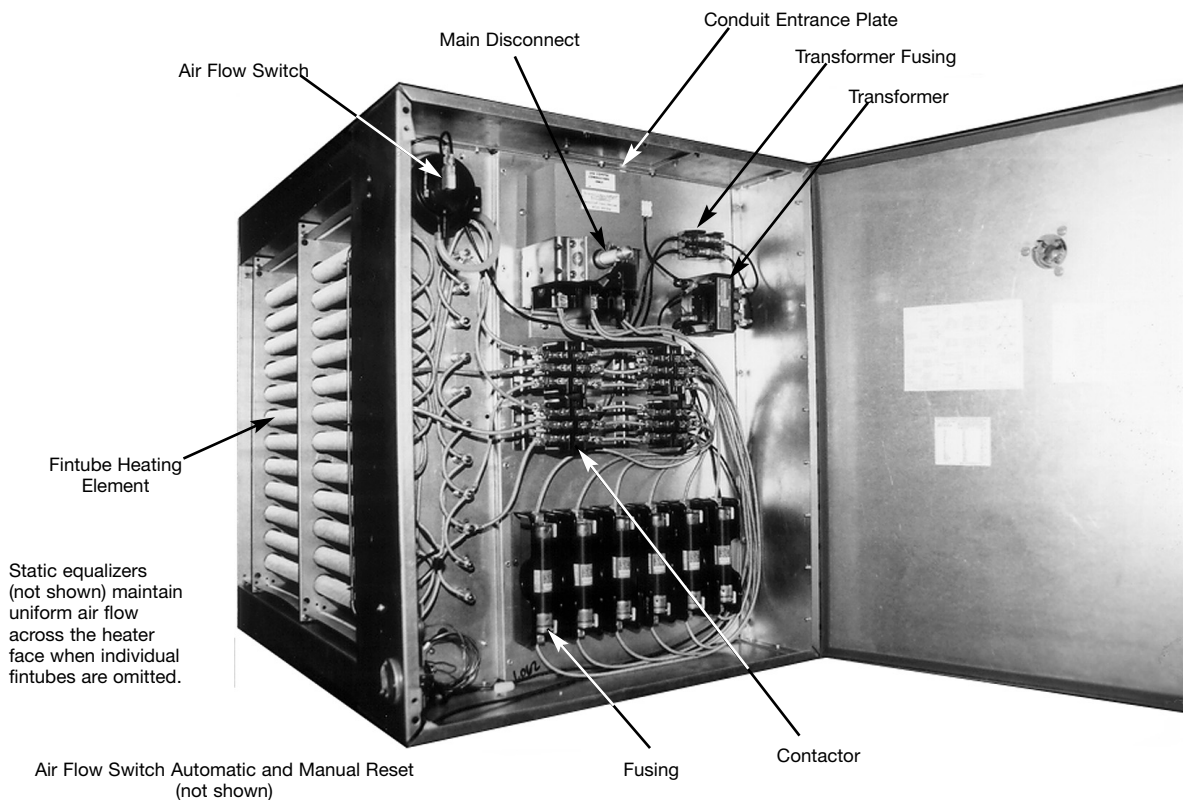

**Contact your local Chromalox Sales Office with Complete heater catalog number or part number.**

## CATALOG NUMBER DESIGNATION SYSTEM

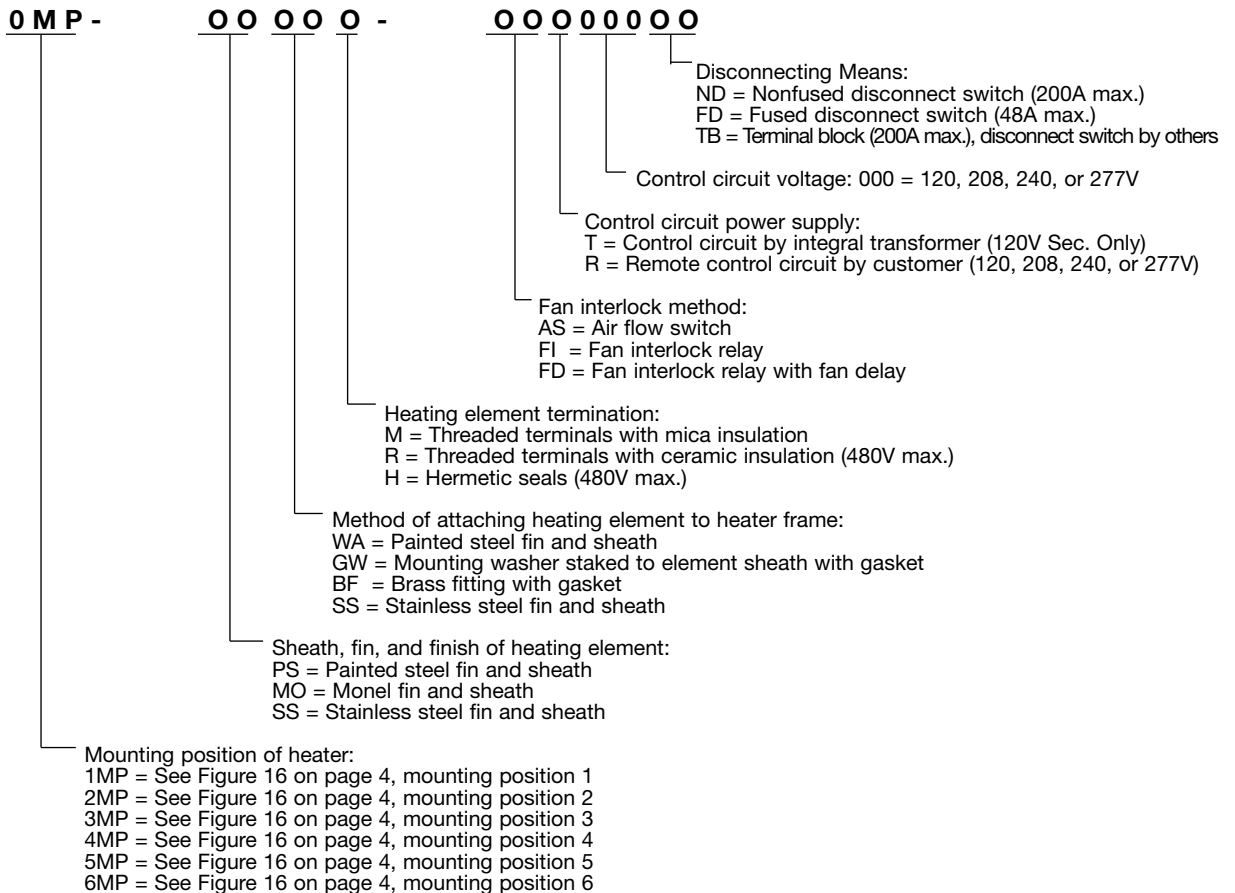
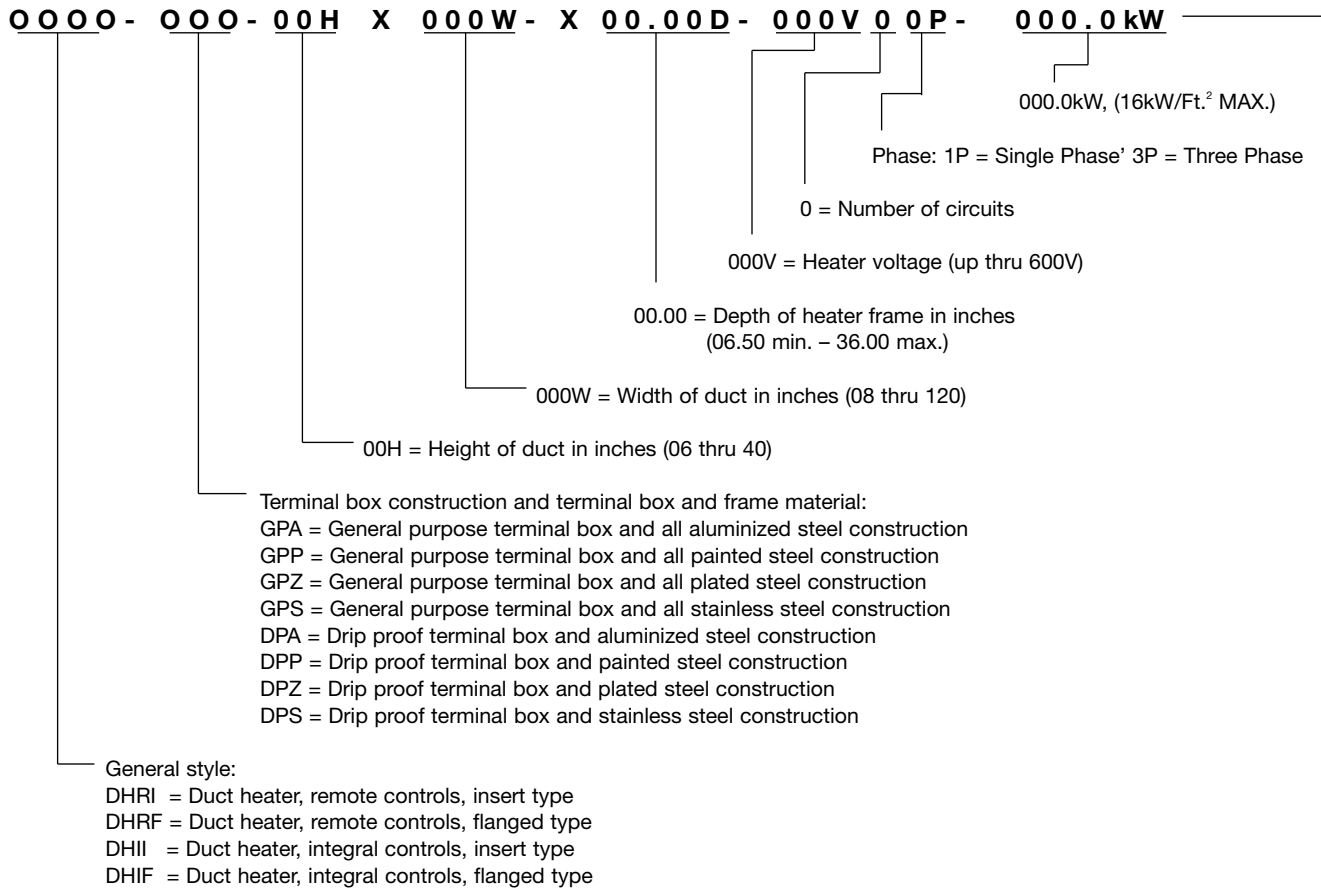

**Limited Warranty:**  
Please refer to the Chromalox limited warranty applicable to this product at  
<http://www.chromalox.com/customer-service/policies/termsofsale.aspx>.

**Chromalox<sup>®</sup>**  
**PRECISION HEAT AND CONTROL**

2150 N. RULON WHITE BLVD., OGDEN, UT 84404  
Phone: 1-800-368-2493      [www.chromalox.com](http://www.chromalox.com)