

***lenovo***

ThinkCentre  
Hardware Maintenance Manual



ThinkThink**ThinkCentre**Think

Machine Types: 0266, 0384, 2491, 4168, 5027, 5067, 7516, and 7519





# ThinkCentre Hardware Maintenance Manual

Machine Types: 0266, 0384, 2491, 4168, 5027, 5067, 7516, and 7519

**Note**

Before using this information and the product it supports, be sure to read and understand the Chapter 2 “Safety information” on page 3 and Appendix A “Notices” on page 183.

**Fourth Edition (August 2011)**

**© Copyright Lenovo 2011.**

LIMITED AND RESTRICTED RIGHTS NOTICE: If data or software are delivered pursuant a General Services Administration “GSA” contract, use, reproduction, or disclosure is subject to restrictions set forth in Contract No. GS-35F-05925.

---

# Contents

## Chapter 1. About this manual . . . . . 1

Important safety information . . . . .	1
Important information about replacing RoHS compliant FRUs . . . . .	1

## Chapter 2. Safety information . . . . . 3

General safety . . . . .	3
Electrical safety . . . . .	3
Voltage-selection switch . . . . .	5
Safety inspection guide . . . . .	5
Handling electrostatic discharge-sensitive devices . . . . .	6
Grounding requirements . . . . .	6
Safety notices (multi-lingual translations) . . . . .	6

## Chapter 3. General information . . . . . 29

Lenovo Welcome. . . . .	29
Lenovo ThinkVantage Tools . . . . .	29
Lenovo ThinkVantage Toolbox . . . . .	29
ThinkVantage Productivity Center . . . . .	29
Additional information resources . . . . .	30
Specifications . . . . .	31

## Chapter 4. General checkout . . . . . 33

Checking for power problems. . . . .	33
Problem determination tips. . . . .	34

## Chapter 5. Diagnostics . . . . . 37

Lenovo ThinkVantage Toolbox . . . . .	37
PC-Doctor for DOS . . . . .	37
Creating a diagnostic disc . . . . .	37
Running the diagnostic program from a diagnostic disc. . . . .	38
Navigating through the diagnostics programs . . . . .	38
Running tests . . . . .	38
Viewing the test log . . . . .	40

## Chapter 6. Using the Setup Utility program . . . . . 41

Starting the Setup Utility program . . . . .	41
Viewing and changing settings . . . . .	41
Using passwords. . . . .	41
Password considerations. . . . .	42
Power-On Password . . . . .	42
Administrator Password . . . . .	42
Hard Disk Password. . . . .	42
Setting, changing, and deleting a password . . . . .	42

Erasing lost or forgotten passwords (clearing CMOS) . . . . .	43
Enabling or disabling a device . . . . .	43
Selecting a startup device . . . . .	44
Selecting a temporary startup device . . . . .	44
Selecting or changing the startup device sequence . . . . .	44
Smart performance choices . . . . .	44
Exiting from the Setup Utility program . . . . .	45

## Chapter 7. Symptom-to-FRU index . . . 47

Hard disk drive boot error . . . . .	47
Diagnostic error codes . . . . .	47
Beep symptoms . . . . .	63
POST error codes . . . . .	63
Miscellaneous error messages . . . . .	65
Undetermined problems . . . . .	66

## Chapter 8. Replacing FRUs . . . . . 69

Locations. . . . .	69
Locating connectors, controls, and indicators on the front of your computer . . . . .	69
Locating connectors on the rear of your computer . . . . .	70
Locating components . . . . .	71
Locating parts on the system board . . . . .	71
Opening the computer cover . . . . .	72
Removing and reinstalling the front bezel . . . . .	73
Installing or replacing a memory module . . . . .	74
Installing or replacing the PCI card . . . . .	75
Replacing the hard disk drive . . . . .	77
Replacing the optical drive . . . . .	78
Replacing the battery . . . . .	80
Replacing the heat sink . . . . .	81
Replacing the microprocessor . . . . .	82
Replacing the system board . . . . .	86
Replacing the system fan assembly . . . . .	88
Replacing the internal speaker . . . . .	91
Replacing the front audio and USB assembly . . . . .	92
Replacing the ac power adapter . . . . .	94
Replacing the ac power adapter bracket . . . . .	95
Completing the parts replacement . . . . .	98

## Chapter 9. FRU lists . . . . . 99

Overall MT: 0266, 0384, 2491, 4168, 5027, 5067, , and 7519 . . . . .	99
Mechanical FRUs . . . . .	108
Keyboard and Mouse . . . . .	113

Adapters and miscellaneous FRUs . . . . .	147
Power Cords . . . . .	149
Recovery discs . . . . .	156
Windows 7 Professional 32 Recovery CD . . . . .	156
Windows 7 Home Basic 32 Recovery CD . . . . .	162
Windows 7 Home Premium 64 Recovery CD . . . . .	163
Windows 7 Home Premium 32 Recovery CD . . . . .	164
Windows XP Professional 32 Recovery CD . . . . .	167
Windows 7 Professional 64 Recovery CD . . . . .	170
Windows XP Professional Generic Recovery CD . . . . .	175
Windows Vista Business 32 Recovery CD . . . . .	176
Windows Vista Home Basic 32 Recovery CD . . . . .	177
<b>Chapter 10. Additional service information . . . . .</b>	<b>179</b>
Security features . . . . .	179

Hardware-controlled passwords . . . . .	179
Operating system password . . . . .	179
Vital Product Data . . . . .	179
Secure Managed Client . . . . .	179
BIOS levels . . . . .	179
Updating (flashing) the BIOS from a disc . . . . .	180
Updating (flashing) the BIOS from your operating system . . . . .	180
Recovering from a POST/BIOS update failure . . . . .	181
Power management . . . . .	181
Automatic configuration and power interface (ACPI) BIOS . . . . .	181
Automatic Power-On features . . . . .	181
<b>Appendix A. Notices . . . . .</b>	<b>183</b>
Television output notice . . . . .	184
Trademarks . . . . .	184
<b>Index . . . . .</b>	<b>185</b>

---

## Chapter 1. About this manual

This manual contains service and reference information for ThinkCentre® computer machine types listed on the front cover. This manual is intended only for trained servicers who are familiar with Lenovo® computer products.

**Note:** Be sure to read and understand the Chapter 2 “Safety information” on page 3 before using the information in this manual.

This manual includes a complete FRU part number list for each machine type listed on the front cover. If you have Internet access, the FRU part numbers are also available at:  
<http://www.lenovo.com/support>

---

### Important safety information

Be sure to read all caution and danger statements in this manual before performing any of the instructions.

Veillez lire toutes les consignes de type DANGER et ATTENTION du présent document avant d'exécuter les instructions.

Lesen Sie unbedingt alle Hinweise vom Typ "ACHTUNG" oder "VORSICHT" in dieser Dokumentation, bevor Sie irgendwelche Vorgänge durchführen

Leggere le istruzioni introdotte da ATTENZIONE e PERICOLO presenti nel manuale prima di eseguire una qualsiasi delle istruzioni

Certifique-se de ler todas as instruções de cuidado e perigo neste manual antes de executar qualquer uma das instruções

Es importante que lea todas las declaraciones de precaución y de peligro de este manual antes de seguir las instrucciones.

تأكد من قراءة كل التحذيرات الموجودة في هذا الكتاب قبل اتباع هذه التعليمات .

执行任何说明之前，请确保已阅读本书中的所有警告和危险声明。

執行任何指示前，請確實閱讀本書中的所有警告及危險聲明。

ודאו שקראתם את כל הודעות האזהרה והסכנה במסמך זה לפני שתבצעו פעולה כלשהי.

본 사용 설명서에 기재된 내용을 실행하기 전에 모든 주의사항 및 위험사항을 숙지하십시오.

---

### Important information about replacing RoHS compliant FRUs

**RoHS, the Restriction of Hazardous Substances in Electrical and Electronic Equipment Directive (2002/95/EC) is a European Union legal requirement affecting the global electronics industry. RoHS requirements must be implemented on Lenovo products placed on the market and sold in the European Union after June, 2006. Products on the market before June, 2006 are not required to have RoHS compliant parts. If the parts are not compliant originally, replacement parts can also be noncompliant, but in all cases, if the parts are compliant, the replacement parts must also be compliant.**

**Note:** RoHS and non-RoHS FRU part numbers with the same fit and function are identified with unique FRU part numbers.

Lenovo plans to transition to RoHS compliance well before the implementation date and expects its suppliers to be ready to support Lenovo's requirements and schedule in the EU. Products sold in 2005 will contain some RoHS compliant FRUs. The following statement pertains to these products and any product Lenovo produces containing RoHS compliant parts.

RoHS compliant ThinkCentre parts have unique FRU part numbers. Before or after June 2006, failed RoHS compliant parts must always be replaced using RoHS compliant FRUs, so only the FRUs identified as compliant in the system hardware maintenance manual or direct substitutions for those FRUs can be used.

Products marketed before June 2006		Products marketed after June 2006	
Current or original part	Replacement FRU	Current or original part	Replacement FRU
Non-RoHS	Can be Non-RoHS	Must be RoHS	Must be RoHS
Non-RoHS	Can be RoHS		
Non-RoHS	Can substitute for RoHS		
RoHS	Must be RoHS		

**Note:** A direct substitution is a part with a different FRU part number that is automatically shipped by the distribution center at the time of order.



---

## Chapter 2. Safety information

This chapter contains the safety information that you need to be familiar with before servicing a computer.

---

### General safety

Follow these rules to ensure general safety:

- Observe good housekeeping in the area of the machines during and after maintenance.
- When lifting any heavy object:
  1. Ensure you can stand safely without slipping.
  2. Distribute the weight of the object equally between your feet.
  3. Use a slow lifting force. Never move suddenly or twist when you attempt to lift.
  4. Lift by standing or by pushing up with your leg muscles; this action removes the strain from the muscles in your back. *Do not attempt to lift any objects that weigh more than 16 kg (35 lb) or objects that you think are too heavy for you.*
- Do not perform any action that causes hazards to the customer, or that makes the equipment unsafe.
- Before you start the machine, ensure that other service representatives and the customer's personnel are not in a hazardous position.
- Place removed covers and other parts in a safe place, away from all personnel, while you are servicing the machine.
- Keep your tool case away from walk areas so that other people will not trip over it.
- Do not wear loose clothing that can be trapped in the moving parts of a machine. Ensure that your sleeves are fastened or rolled up above your elbows. If your hair is long, fasten it.
- Insert the ends of your necktie or scarf inside clothing or fasten it with a nonconductive clip, approximately 8 centimeters (3 inches) from the end.
- Do not wear jewelry, chains, metal-frame eyeglasses, or metal fasteners for your clothing.  
**Remember:** Metal objects are good electrical conductors.
- Wear safety glasses when you are: hammering, drilling soldering, cutting wire, attaching springs, using solvents, or working in any other conditions that might be hazardous to your eyes.
- After service, reinstall all safety shields, guards, labels, and ground wires. Replace any safety device that is worn or defective.
- Reinstall all covers correctly before returning the machine to the customer.

---

### Electrical safety



#### **CAUTION:**

**Electrical current from power, telephone, and communication cables can be hazardous. To avoid personal injury or equipment damage, disconnect the attached power cords, telecommunication systems, networks, and modems before you open the computer covers, unless instructed otherwise in the installation and configuration procedures.**

Observe the following rules when working on electrical equipment.

**Important:** Use only approved tools and test equipment. Some hand tools have handles covered with a soft material that does not insulate you when working with live electrical currents. Many customers have, near their equipment, rubber floor mats that contain small conductive fibers to decrease electrostatic discharges. Do not use this type of mat to protect yourself from electrical shock.

- Find the room emergency power-off (EPO) switch, disconnecting switch, or electrical outlet. If an electrical accident occurs, you can then operate the switch or unplug the power cord quickly.
- Do not work alone under hazardous conditions or near equipment that has hazardous voltages.
- Disconnect all power before:
  - Performing a mechanical inspection
  - Working near power supplies
  - Removing or installing Field Replaceable Units
- Before you start to work on the machine, unplug the power cord. If you cannot unplug it, ask the customer to power-off the wall box that supplies power to the machine and to lock the wall box in the off position.
- If you need to work on a machine that has exposed electrical circuits, observe the following precautions:
  - Ensure that another person, familiar with the power-off controls, is near you.  
**Remember:** Another person must be there to switch off the power, if necessary.
  - Use only one hand when working with powered-on electrical equipment; keep the other hand in your pocket or behind your back.  
**Remember:** There must be a complete circuit to cause electrical shock. By observing the above rule, you may prevent a current from passing through your body.
  - When using testers, set the controls correctly and use the approved probe leads and accessories for the testers.
  - Stand on suitable rubber mats (obtained locally, if necessary) to insulate you from grounds such as metal floor strips and machine frames.

Observe the special safety precautions when you work with very high voltages; these instructions are in the safety sections of maintenance information. Use extreme care when measuring high voltages.

- Regularly inspect and maintain your electrical hand tools for safe operational condition.
- Do not use worn or broken tools and testers.
- *Never assume* that power has been disconnected from a circuit. First, *check* that it has been powered-off.
- Always look carefully for possible hazards in your work area. Examples of these hazards are moist floors, nongrounded power extension cables, power surges, and missing safety grounds.
- Do not touch live electrical circuits with the reflective surface of a plastic dental mirror. The surface is conductive; such touching can cause personal injury and machine damage.
- Do not service the following parts with the power on when they are removed from their normal operating places in a machine:
  - Power supply units
  - Pumps
  - Blowers and fans
  - Motor generatorsand similar units. (This practice ensures correct grounding of the units.)
- If an electrical accident occurs:
  - Use caution; do not become a victim yourself.
  - Switch off power.
  - Send another person to get medical aid.

---

## Voltage-selection switch

Some computers are equipped with a voltage-selection switch located near the power-cord connection point on the computer. If your computer has a voltage-selection switch, ensure that you set the switch to match the voltage available at your electrical outlet. Setting the voltage-selection switch incorrectly can cause permanent damage to the computer.

If your computer does not have a voltage-selection switch, your computer is designed to operate only at the voltage provided in the country or region where the computer was originally purchased.

If you relocate your computer to another country, be aware of the following:

- If your computer does not have a voltage-selection switch, do not connect the computer to an electrical outlet until you have verified that the voltage provided is the same as it was in the country or region where the computer was originally purchased.
- If your computer has a voltage-selection switch, do not connect the computer to an electrical outlet until you have verified that the voltage-selection switch is set to match the voltage provided in that country or region.

If you are not sure of the voltage provided at your electrical outlet, contact your local electric company or refer to official Web sites or other literature for travelers to the country or region where you are located.

---

## Safety inspection guide

The intent of this inspection guide is to assist you in identifying potentially unsafe conditions on these products. Each machine, as it was designed and built, had required safety items installed to protect users and service personnel from injury. This guide addresses only those items. However, good judgment should be used to identify potential safety hazards due to attachment of features or options not covered by this inspection guide.

If any unsafe conditions are present, you must determine how serious the apparent hazard could be and whether you can continue without first correcting the problem.

Consider these conditions and the safety hazards they present:

- Electrical hazards, especially primary power (primary voltage on the frame can cause serious or fatal electrical shock).
- Explosive hazards, such as a damaged CRT face or bulging capacitor
- Mechanical hazards, such as loose or missing hardware

The guide consists of a series of steps presented in a checklist. Begin the checks with the power off, and the power cord disconnected.

Checklist:

1. Check exterior covers for damage (loose, broken, or sharp edges).
2. Power-off the computer. Disconnect the power cord.
3. Check the power cord for:
  - a. A third-wire ground connector in good condition. Use a meter to measure third-wire ground continuity for 0.1 ohm or less between the external ground pin and frame ground.
  - b. The power cord should be the appropriate type as specified in the parts listings.
  - c. Insulation must not be frayed or worn.
4. Remove the cover.

5. Check for any obvious alterations. Use good judgment as to the safety of any alterations.
6. Check inside the unit for any obvious unsafe conditions, such as metal filings, contamination, water or other liquids, or signs of fire or smoke damage.
7. Check for worn, frayed, or pinched cables.
8. Check that the power-supply cover fasteners (screws or rivets) have not been removed or tampered with.

---

## Handling electrostatic discharge-sensitive devices

Any computer part containing transistors or integrated circuits (ICs) should be considered sensitive to electrostatic discharge (ESD). ESD damage can occur when there is a difference in charge between objects. Protect against ESD damage by equalizing the charge so that the machine, the part, the work mat, and the person handling the part are all at the same charge.

### Notes:

1. Use product-specific ESD procedures when they exceed the requirements noted here.
2. Make sure that the ESD protective devices you use have been certified (ISO 9000) as fully effective.

When handling ESD-sensitive parts:

- Keep the parts in protective packages until they are inserted into the product.
- Avoid contact with other people while handling the part.
- Wear a grounded wrist strap against your skin to eliminate static on your body.
- Prevent the part from touching your clothing. Most clothing is insulative and retains a charge even when you are wearing a wrist strap.
- Use the black side of a grounded work mat to provide a static-free work surface. The mat is especially useful when handling ESD-sensitive devices.
- Select a grounding system, such as those listed below, to provide protection that meets the specific service requirement.

**Note:** The use of a grounding system is desirable but not required to protect against ESD damage.

- Attach the ESD ground clip to any frame ground, ground braid, or green-wire ground.
- Use an ESD common ground or reference point when working on a double-insulated or battery-operated system. You can use coax or connector-outside shells on these systems.
- Use the round ground-prong of the ac plug on ac-operated computers.

---

## Grounding requirements

Electrical grounding of the computer is required for operator safety and correct system function. Proper grounding of the electrical outlet can be verified by a certified electrician.

---

## Safety notices (multi-lingual translations)

The caution and danger safety notices in this section are provided in the following languages:

- English
- Arabic
- Brazilian/Portuguese
- Chinese (simplified)
- Chinese (traditional)

- French
- German
- Hebrew
- Italian
- Korean
- Spanish



**DANGER**

Electrical current from power, telephone and communication cables is hazardous.

**To avoid a shock hazard:**

- **Do not connect or disconnect any cables or perform installation, maintenance, or reconfiguration of this product during an electrical storm.**
- **Connect all power cords to a properly wired and grounded electrical outlet.**
- **Connect to properly wired outlets any equipment that will be attached to this product.**
- **When possible, use one hand only to connect or disconnect signal cables.**
- **Never turn on any equipment when there is evidence of fire, water, or structural damage.**
- **Disconnect the attached power cords, telecommunications systems, networks, and modems before you open the device covers, unless instructed otherwise in the installation and configuration procedures.**
- **Connect and disconnect cables as described in the following tables when installing, moving, or opening covers on this product or attached devices.**

To Connect	To Disconnect
1. Turn everything OFF. 2. First, attach all cables to devices. 3. Attach signal cables to connectors. 4. Attach power cords to outlet. 5. Turn device ON.	1. Turn everything OFF. 2. First, remove power cords from outlet. 3. Remove signal cables from connectors. 4. Remove all cables from devices.



**CAUTION:**

**When replacing the lithium battery, use only Part Number 45C1566 or an equivalent type battery recommended by the manufacturer. If your system has a module containing a lithium battery, replace it only with the same module type made by the same manufacturer. The battery contains lithium and can explode if not properly used, handled, or disposed of. Do not:**

- **Throw or immerse into water**
- **Heat to more than 100°C (212°F)**
- **Repair or disassemble**

**Dispose of the battery as required by local ordinances or regulations.**



**CAUTION:**

When laser products (such as CD-ROMs, DVD-ROM drives, fiber optic devices, or transmitters) are installed, note the following:

- Do not remove the covers. Removing the covers of the laser product could result in exposure to hazardous laser radiation. There are no serviceable parts inside the device.
- Use of controls or adjustments or performance of procedures other than those specified herein might result in hazardous radiation exposure.



**DANGER**

Some laser products contain an embedded Class 3A or Class 3B laser diode. Note the following:

Laser radiation when open. Do not stare into the beam, do not view directly with optical instruments, and avoid direct exposure to the beam.



≥18 kg (37 lbs)



≥32 kg (70.5 lbs)



≥55 kg (121.2 lbs)

**CAUTION:**

Use safe practices when lifting.



**CAUTION:**

The power control button on the device and the power switch on the power supply do not turn off the electrical current supplied to the device. The device also might have more than one power cord. To remove all electrical current from the device, ensure that all power cords are disconnected from the power source.



التيار الكهربائي الموجود بمصدر الطاقة أو أجهزة التليفون أو أسلاك الاتصالات يشكل خطورة.

لتفادي مخاطر الصدمات الكهربائية:

لا تحاول توصيل أو فصل أي أسلاك أو القيام بعمليات تركيب أو صيانة أو إعادة توصيف لهذا المنتج أثناء وجود عاصفة كهربائية.

يجب توصيل كل أسلاك الكهرباء في مخارج كهرباء ذات توصيلات أسلاك وتوصيلات أرضية صحيحة  
يجب توصيل أي جهاز سيتم الحاقه بهذا المنتج في مخارج كهرباء ذات توصيلات أسلاك صحيحة.

وإن أمكن يجب استخدام يد واحدة فقط في توصيل أو فصل أسلاك الإشارة.

لا تحاول تشغيل أي جهاز إذا كان هناك أثر لحرق أو مياه أو تلف بالمكونات

يجب فصل أسلاك الكهرباء وأنظمة الاتصالات وشبكات الاتصال وأجهزة المودم الملحقة قبل فتح أغطية الجهاز، ما لم يتم طلب خلاف ذلك في التعليمات الخاصة بالتركيب والتوصيف.  
قم بتوصيل وفصل الأسلاك كما هو موضح في الجدول التالي وذلك عند القيام بعمليات التركيب أو النقل أو فتح أغطية هذا المنتج أو الأجهزة الملحقة.

#### للفصل:

- قم بإيقاف كل شيء.
- أولاً، قم بفصل كل أسلاك الكهرباء من المخرج.
- قم بفصل أسلاك الإشارة من الموصلات.
- قم بفصل كل الأسلاك من الأجهزة.

#### للتوصيل:

- قم بإيقاف كل شيء.
- أولاً، قم بتوصيل كل الأسلاك بالأجهزة.
- قم بتوصيل أسلاك الإشارة في لموصلات.
- قم بتوصيل أسلاك الكهرباء في المخارج.
- قم بتشغيل الجهاز.



تنبيه :

عند استبدال البطارية الليثيوم، استخدم فقط رقم الجزء الخاص **Part Number 45C1566** أو نوع آخر يكون على نفس مستوى الكفاءة يحدده لك المصنع.

إذا كان النظام الخاص يستخدم معه بطارية ليثيوم قم باستبدالها بنفس النوع الذي تم صناعته من خلال نفس المصنع. تحتوي البطارية على مادة الليثيوم ويمكن أن تنفجر في حالة عدم استخدامها أو التعامل معها بطريقة صحيحة أو عند التخلص منها بطريقة خطأ.

لا تقم بـ:

- القاء البطارية أو غمرها في الماء
- تسخينها أعلى من ١٠٠ درجة مئوية و(٢١٢ ° فهرنهايت)
- بتصليحها أو فكها

تخلص من البطارية طبقاً للقانون أو النظام المحلي .



تنبيه :  
أثناء تركيب منتجات ليزر (مثل CD-ROMs أو وحدة تشغيل DVD أو أجهزة Fiber Optic أو وحدات الإرسال) يجب مراعاة الآتي:

لا تنزع الأغطية. قد ينتج عن نزع أغطية منتج الليزر انفجار أشعة الليزر شديدة الخطورة.  
لا يوجد أجزاء يمكن تغييرها داخل الجهاز. قد ينتج عن استخدام تحكيمات أو تعديلات أو عمل أي تصرفات أخرى تخالف ما هو محدد هنا إلى انفجار أشعة شديدة الخطورة.



خطر

تحتوي بعض منتجات الليزر على الفئة دايود ليزر مدمج من الفئة Class 3A أو Class 3B. يجب مراعاة الآتي .

أشعة الليزر عند الفتح. لا تحقق إلى الإشعاع و لا تنظر إليه مباشرة بواسطة أي أجهزة مرئية وتجنب التعرض المباشر للإشعاع .

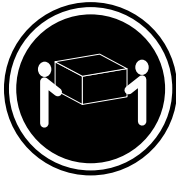

≥18 kg (37 lbs)



≥32 kg (70.5 lbs)



≥55 kg (121.2 lbs)

تنبيه :  
يجب استخدام ممارسات أمانة عند الرفع



تنبيه :  
لا يقر زر التحكم في التشغيل الموجود على الجهاز والمفتاح الكهربائي الموجود على لوحة التحكم بإيقاف التيار الكهربائي المار بالجهاز. قد يكون للجهاز أكثر من سلك كهربائي واحد. لإيقاف التيار الكهربائي المار بالجهاز، تأكد من فصل جميع أسلاك الكهرباء من مصدر الكهرباء .

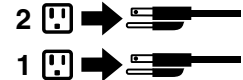

PERIGO



A corrente elétrica proveniente de cabos de alimentação, de telefone e de comunicações é perigosa.

Para evitar risco de choque elétrico:

- Não conecte nem desconecte nenhum cabo ou execute instalação, manutenção ou reconfiguração deste produto durante uma tempestade com raios.
- Conecte todos os cabos de alimentação a tomadas elétricas corretamente instaladas e aterradas.
- Todo equipamento que for conectado a este produto deve ser conectado a tomadas corretamente instaladas.
- Quando possível, utilize apenas uma das mãos para conectar ou desconectar cabos de sinal.
- Nunca ligue nenhum equipamento quando houver evidência de fogo, água ou danos estruturais.
- Antes de abrir tampas de dispositivos, desconecte cabos de alimentação, sistemas de telecomunicação, redes e modems conectados, a menos que especificado de maneira diferente nos procedimentos de instalação e configuração.
- Conecte e desconecte os cabos conforme descrito na tabela apresentada a seguir ao instalar, mover ou abrir tampas deste produto ou de dispositivos conectados.

Para Conectar:	Para Desconectar:
<ol style="list-style-type: none"><li>1. DESLIGUE Tudo.</li><li>2. Primeiramente, conecte todos os cabos aos dispositivos.</li><li>3. Conecte os cabos de sinal aos conectores.</li><li>4. Conecte os cabos de alimentação às tomadas.</li><li>5. LIGUE os dispositivos.</li></ol>	<ol style="list-style-type: none"><li>1. DESLIGUE Tudo.</li><li>2. Primeiramente, remova os cabos de alimentação das tomadas.</li><li>3. Remova os cabos de sinal dos conectores.</li><li>4. Remova todos os cabos dos dispositivos.</li></ol>



#### **CUIDADO:**

**Ao substituir a bateria de lítio, utilize apenas uma bateria com Número de Peça 45C1566 ou um tipo de bateria equivalente recomendado pelo Se o seu sistema possui um módulo com uma bateria de lítio, substitua-o apenas por um módulo do mesmo tipo e do mesmo fabricante. A bateria contém lítio e pode explodir se não for utilizada, manuseada ou descartada de maneira correta.**

Não:

- Jogue ou coloque na água
- Aqueça a mais de 100°C (212°F)
- Conserte nem desmonte

Descarte a bateria conforme requerido pelas leis ou regulamentos locais.



#### **PRECAUCIÓN:**

Quando produtos a laser (como unidades de CD-ROMs, unidades de DVD-ROM, dispositivos de fibra ótica ou transmissores) estiverem instalados, observe o seguinte:

- Não remova as tampas. A remoção das tampas de um produto a laser pode resultar em exposição prejudicial à radiação de laser. Não existem peças que podem ser consertadas no interior do dispositivo.
- A utilização de controles ou ajustes ou a execução de procedimentos diferentes dos especificados aqui pode resultar em exposição prejudicial à radiação.

## PERIGO

Alguns produtos a laser contêm diodo de laser integrado da Classe 3A ou da Classe 3B. Observe o seguinte:

Radiação a laser quando aberto. Não olhe diretamente para o feixe a olho nu ou com instrumentos ópticos e evite exposição direta ao feixe.



≥18 kg (37 lbs)



≥32 kg (70.5 lbs)

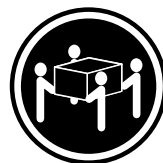

≥55 kg (121.2 lbs)

## CUIDADO:

Utilize procedimentos de segurança para levantar equipamentos.



## CUIDADO:

O botão de controle de alimentação do dispositivo e o botão para ligar/desligar da fonte de alimentação não desligam a corrente elétrica fornecida ao dispositivo. O dispositivo também pode ter mais de um cabo de alimentação. Para remover toda a corrente elétrica do dispositivo, assegure que todos os cabos de alimentação estejam desconectados da fonte de alimentação.



危险

电源、电话和通信电缆中的电流是危险的。

为避免电击危险：

- 请勿在雷电期间连接或断开任何电缆的连接，或者对本产品进行安装、维护或重新配置。
- 将所有电源线连接到正确连线和妥善接地的电源插座。
- 将所有要连接到该产品的设备连接到正确连线的插座。
- 如果可能，请仅使用一只手来连接或断开信号电缆的连接。
- 切勿在有火、水、结构损坏迹象的情况下开启任何设备。
- 在打开设备外盖之前请断开已连接的电源线、远程通信系统、网络和调制解调器，除非在安装和配置过程中另有说明。
- 当安装、移动或打开该产品或连接设备的外盖时，请按照下表所述来连接或断开电缆的连接。

要连接	要断开连接
<ol style="list-style-type: none"><li>1. 切断所有电源。</li><li>2. 首先将所有电缆连接到设备。</li><li>3. 将信号电缆连接到接口。</li><li>4. 将电源线连接到插座。</li><li>5. 开启设备。</li></ol>	<ol style="list-style-type: none"><li>1. 切断所有电源。</li><li>2. 首先从插座上拔出电源线。</li><li>3. 从接口上拔出信号电缆。</li><li>4. 从设备上拔出所有电缆。</li></ol>



警告：  
更换锂电池时，请仅使用部件号为 45C1566 的电池或制造商推荐的同类电池。如果您的系统有包含锂电池的模块，请仅使用同一制造商生产的相同模块类型来替换该模块。该电池中含有锂，如果使用、操作或处理不当，可能会发生爆炸。

切勿：

- 投入或浸入水中
- 加热到 100°C (212°F) 以上
- 维修或拆卸

请按照当地法令或条例的要求处理电池。



警告：  
安装激光产品（例如 CD-ROM、DVD-ROM 驱动器、光纤设备或发射设备）时，请注意以下声明：

- 请勿卸下外盖。卸下激光产品的外盖可能导致遭受激光辐射的危险。该设备内没有可维修的部件。
- 如果不按照此处指定的过程进行控制、调整或操作，则有可能导致遭受辐射的危险。



危险

某些激光产品包含嵌入式 3A 类或 3B 类激光二极管。请注意以下声明：

打开后有激光辐射。请勿注视光束，请勿直接用光学仪器查看，并请避免直接暴露在光束中。



≥18 千克 (37 磅)



≥32 千克 (70.5 磅)

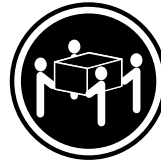

≥55 千克 (121.2 磅)

警告：  
抬起时请采取安全措施。



警告：  
设备上的电源控制按钮和电源上的电源开关不会切断供给该设备的电流。该设备还可能有多条电源线。要切断该设备的所有电流，请确保所有电源线都与电源断开连接。

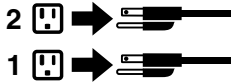

## 危險

電源、電話及通訊纜線上的電流都具有危險性。

若要避免觸電危險：

- 請勿在雷雨期間，連接或拔除纜線、執行安裝、維護或重新配置本產品。
- 將所有電源線連接到正確配線及接地的電源插座。
- 任何與本產品連接的設備都必須連接到配線妥當的電源插座。
- 請盡可能用單手連接或拔除信號線。
- 發生火災、水災或結構損害時，絕對不要開啟任何設備。
- 除非在安裝及配置程序中另有指示，否則在開啟裝置機蓋之前，請拔掉連接的電源線、電信系統、網路及數據機。
- 安裝、移動或開啟本產品或附屬裝置的機蓋時，請遵循下列說明連接及拔掉纜線。

連線	切斷連線
<ol style="list-style-type: none"><li>1. 關閉所有開關。</li><li>2. 首先，連接所有接線到裝置。</li><li>3. 連接信號線到接頭。</li><li>4. 連接電源線到插座。</li><li>5. 開啟裝置。</li></ol>	<ol style="list-style-type: none"><li>1. 關閉所有開關。</li><li>2. 首先，拔掉插座上的電源線。</li><li>3. 拔掉接頭上的信號線。</li><li>4. 拔掉裝置上所有接線。</li></ol>



警告：

更換鋰電池時，請僅使用產品編號 **45C1566** 或製造商所建議的同類型電池。  
如果您的系統中含有鋰電池模組，請僅使用同一家製造商所生產的相同模組進行更換。  
如果未以正確方式使用、處理或棄置含鋰的電池，會有爆炸的危險。  
請勿：

- 沾溼或浸入水中
  - 置於 **100°C (212°F)** 以上的高溫環境
  - 修理或拆開
- 請按照各地區有關廢棄電池的法令和規定處理舊電池。



警告：

- 請勿移除機蓋。移除雷射產品的機蓋，可能會導致暴露在危險的雷射輻射中。裝置內部並無可自行維修的零件。
- 利用或執行非本文中所指定的控制、調整及執行程序，可能會導致危險的輻射外洩。



危險

部分雷射產品含有內嵌式 **Class 3A** 或 **Class 3B** 雷射二極體。請注意下列事項：  
在開啟光碟機時，會發生雷射輻射。請勿直視光束或用光學儀器直接檢視，並避免直接暴露在光束中。



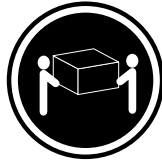

≥ 18 公斤 (37 磅)



≥ 32 公斤 (70.5 磅)



≥ 55 公斤 (121.2 磅)

警告：  
搬運時請注意安全。



警告：  
裝置上的電源控制按鈕及電源供應器上的電源開關，無法關閉裝置所產生的電流。  
該裝置可能有多條電源線。若要除去裝置流出的所有電流，請確認已切斷所有電源線的電源。

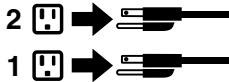

## DANGER

Le courant électrique provenant de l'alimentation, du téléphone et des câbles de transmission peut présenter un danger.

Pour éviter tout risque de choc électrique :

- Ne manipulez aucun câble et n'effectuez aucune opération d'installation, d'entretien ou de reconfiguration de ce produit au cours d'un orage.
- Branchez tous les cordons d'alimentation sur un socle de prise de courant correctement câblé et mis à la terre.
- Branchez sur des socles de prise de courant correctement câblés tout équipement connecté à ce produit.
- Lorsque cela est possible, n'utilisez qu'une seule main pour connecter ou déconnecter les câbles d'interface.
- Ne mettez jamais un équipement sous tension en cas d'incendie ou d'inondation, ou en présence de dommages matériels.
- Avant de retirer les carters de l'unité, mettez celle-ci hors tension et déconnectez ses cordons d'alimentation, ainsi que les câbles qui la relient aux réseaux, aux systèmes de télécommunication et aux modems (sauf instruction contraire mentionnée dans les procédures d'installation et de configuration).
- Lorsque vous installez, que vous déplacez, ou que vous manipulez le présent produit ou des périphériques qui lui sont raccordés, reportez-vous aux instructions ci-dessous pour connecter et déconnecter les différents cordons.

Connexion	Déconnexion
<ol style="list-style-type: none"> <li>1. Mettez les unités HORS TENSION.</li> <li>2. Commencez par brancher tous les cordons sur les unités.</li> <li>3. Branchez les câbles d'interface sur des connecteurs.</li> <li>4. Branchez les cordons d'alimentation sur des prises.</li> <li>5. Mettez les unités SOUS TENSION.</li> </ol>	<ol style="list-style-type: none"> <li>1. Mettez les unités HORS TENSION.</li> <li>2. Débranchez les cordons d'alimentation des prises.</li> <li>3. Débranchez les câbles d'interface des connecteurs.</li> <li>4. Débranchez tous les câbles des unités.</li> </ol>



#### ATTENTION:

Remplacer la pile au lithium usagée par une pile de référence identique exclusivement, (référence 45C1566), ou suivre les instructions du fabricant qui en définit les équivalences. Si votre système est doté d'un module contenant une pile au lithium, vous devez le remplacer uniquement par un module identique, produit par le même fabricant. La pile contient du lithium et peut exploser en cas de mauvaise utilisation, de mauvaise manipulation ou de mise au rebut inappropriée.

Ne pas :

- la jeter à l'eau,
- l'exposer à des températures supérieures à 100°C,
- chercher à la réparer ou à la démonter.

Ne pas mettre la pile à la poubelle. Pour la mise au rebut, se reporter à la réglementation en vigueur.



#### ATTENTION:

Si des produits à laser (tels que des unités de CD-ROM, de DVD-ROM, des unités à fibres optiques, ou des émetteurs) sont installés, prenez connaissance des informations suivantes :

- Ne retirez pas le carter. En ouvrant l'unité de CD-ROM ou de DVD-ROM, vous vous exposez au rayonnement dangereux du laser. Aucune pièce de l'unité n'est réparable.
- Pour éviter tout risque d'exposition au rayon laser, respectez les consignes de réglage et d'utilisation des commandes, ainsi que les procédures décrites dans le présent manuel.



#### DANGER

Certains produits à laser contiennent une diode à laser intégrée de classe 3A ou 3B. Prenez connaissance des informations suivantes:

Rayonnement laser lorsque le carter est ouvert. Evitez toute exposition directe au rayon laser. Evitez de regarder fixement le faisceau ou de l'observer à l'aide d'instruments optiques.



≥18 kg (37 lbs)



≥32 kg (70.5 lbs)



≥55 kg (121.2 lbs)

#### ATTENTION:

Soulevez la machine avec précaution.



#### ATTENTION:

L'interrupteur de contrôle d'alimentation de l'unité et l'interrupteur dubloc d'alimentation ne coupent pas le courant électrique alimentant l'unité. En outre, le système peut être équipé de plusieurs cordons d'alimentation. Pour mettre l'unité hors tension, vous devez déconnecter tous les cordons de la source d'alimentation.



#### VORSICHT

An Netz-, Telefon- und Datenleitungen können gefährliche Spannungen anliegen.

#### Aus Sicherheitsgründen:

- Bei Gewitter an diesem Gerät keine Kabel anschließen oder lösen. Ferner keine Installations-, Wartungs- oder Rekonfigurationsarbeiten durchführen.
- Gerät nur an eine Schutzkontaktsteckdose mit ordnungsgemäß geerdetem Schutzkontakt anschließen.
- Alle angeschlossenen Geräte ebenfalls an Schutzkontaktsteckdosen mit ordnungsgemäß geerdetem Schutzkontakt anschließen.
- Die Signalkabel nach Möglichkeit einhändig anschließen oder lösen, um einen Stromschlag durch Berühren von Oberflächen mit unterschiedlichem elektrischem Potenzial zu vermeiden.
- Geräte niemals einschalten, wenn Hinweise auf Feuer, Wasser oder Gebäudeschäden vorliegen.



- Die Verbindung zu den angeschlossenen Netzkabeln, Telekommunikationssystemen, Netzwerken und Modems ist vor dem Öffnen des Gehäuses zu unterbrechen, sofern in den Installations- und Konfigurationsprozeduren keine anders lautenden Anweisungen enthalten sind.
- Zum Installieren, Transportieren und Öffnen der Abdeckungen des Computers oder der angeschlossenen Einheiten die Kabel gemäß der folgenden Tabelle anschließen und abziehen.

Zum Anschließen der Kabel gehen Sie wie folgt vor	Zum Abziehen der Kabel gehen Sie wie folgt vor
1. Schalten Sie alle Einheiten AUS. 2. Schließen Sie erst alle Kabel an die Einheiten an. 3. Schließen Sie die Signalkabel an die Buchsen an. 4. Schließen Sie die Netzkabel an die Steckdose an. 5. Schalten Sie die Einheit EIN.	1. Schalten Sie alle Einheiten AUS. 2. Ziehen Sie zuerst alle Netzkabel aus den Netzsteckdosen. 3. Ziehen Sie die Signalkabel aus den Buchsen. 4. Ziehen Sie alle Kabel von den Einheiten ab.



**CAUTION:**

Eine verbrauchte Lithiumbatterie nur durch eine Batterie mit der Teilenummer 45C1566 oder eine gleichwertige, vom Hersteller empfohlene Batterie ersetzen. Enthält das System ein Modul mit einer Lithiumbatterie, dieses nur durch ein Modul desselben Typs und von demselben Hersteller ersetzen. Die Batterie enthält Lithium und kann bei unsachgemäßer Verwendung, Handhabung oder Entsorgung explodieren.

Die Batterie nicht:

- mit Wasser in Berührung bringen.
- über 100 C erhitzen.
- reparieren oder zerlegen.

Die örtlichen Bestimmungen für die Entsorgung von Sondermüll beachten.



**ACHTUNG:**

**Bei der Installation von Lasergeräten (wie CD-ROM-Laufwerken, DVD- aufwerken, Einheiten mit Lichtwellenleitertechnik oder Sendern) Folgendes beachten:**

- Die Abdeckungen nicht entfernen. Durch Entfernen der Abdeckungen des Lasergeräts können gefährliche Laserstrahlungen freigesetzt werden. Das Gerät enthält keine zu wartenden Teile.
- Werden Steuerelemente, Einstellungen oder Durchführungen von Prozeduren anders als hier angegeben verwendet, kann gefährliche Laserstrahlung auftreten.



**VORSICHT**

**Einige Lasergeräte enthalten eine Laserdiode der Klasse 3A oder 3B. Beachten Sie Folgendes:**

Laserstrahlung bei geöffneter Verkleidung. Nicht in den Strahl blicken. Keine Lupen oder Spiegel verwenden. Strahlungsbereich meiden.

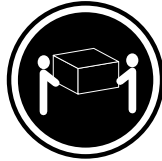

≥18 kg (37 lbs)



≥32 kg (70.5 lbs)



≥55 kg (121.2 lbs)

**ACHTUNG:**

Arbeitsschutzrichtlinien beim Anheben der Maschine beachten.



**ACHTUNG:**

Mit dem Netzschalter an der Einheit und am Netzteil wird die Stromversorgung für die Einheit nicht unterbrochen. Die Einheit kann auch mit mehreren Netzkabeln ausgestattet sein. Um die Stromversorgung für die Einheit vollständig zu unterbrechen, müssen alle zum Gerät führenden Netzkabel vom Netz getrennt werden.



## סכנה

זרם חשמלי המועבר בכבלי חשמל, טלפון ותקשורת הוא מסוכן.

כדי להימנע מסכנת התחשמלות:

- אל תחברו או תנתקו כבלים, ואל תבצעו פעולת התקנה, תחזוקה או שינוי תצורה במוצר זה במהלך סופת ברקים.
- חברו את כל כבלי החשמל לשקע חשמל מחווט ומארק כהלכה.
- חברו כל ציוד שיחובר למוצר זה לשקעי חשמל מחוטים כהלכה.
- במידת האפשר, השתמשו ביד אחת בלבד לחיבור או לניתוק של כבלי אותות.
- לעולם אל תפעילו ציוד כלשהו כאשר יש עדות לנזק מבני או לנזק כתוצאה מאש או ממים.
- נתקו את כבלי החשמל, מערכות התקשורת, התקני הרשת והמודמים המחוברים לפני פתיחת כיסויי ההתקן, אלא אם הליכי ההתקנה וקביעת התצורה מורים אחרת.
- בעת התקנה, העברה או פתיחת כיסויים במוצר זה או בהתקנים המחוברים, חברו ונתקו את הכבלים כמתואר בטבלה שלהלן.

כדי לחבר	כדי לנתק
1. כבו הכל.	1. כבו הכל.
2. ראשית, חברו את כל הכבלים להתקנים.	2. ראשית, נתקו את כבלי החשמל מהשקעים.
3. חברו את כבלי האותות למחברים.	3. נתקו את כבלי האותות מהמחברים.
4. חברו את כבלי החשמל לשקעים.	4. הסירו את כל הכבלים מההתקנים.
5. הפעילו את ההתקן.	



זהירות:

בעת החלפת סוללת הליתיום, השתמשו רק בסוללה בעלת מק"ט 45C1566 או בסוג תואם שהומלץ על ידי היצרן. אם המערכת כוללת מודול המכיל סוללת ליתיום, החליפו אותו רק במודול מאותו סוג ומתוצרת אותו יצרן. הסוללה מכילה ליתיום, ועלולה להתפוצץ אם לא משתמשים ומטפלים בה או משליכים אותה כראוי.

לעולם:

- אל תטבלו במים
  - אל תחממו לטמפרטורה הגבוהה מ-100°C (212°F)
  - אל תתקנו או תפרקו
- השליכו את הסוללה כנדרש לפי התקנות והחוקים המקומיים.



זהירות:

בעת התקנת מוצרי לייזר (כגון כונני תקליטורים ו-DVD), התקני סיב אופטי או משדרים), שימו לב לאזהרות הבאות:

- אל תסירו את הכיסויים. הסרת הכיסויים של מוצר הלייזר עלולה לגרום לחשיפה לקרינת לייזר מסוכנת. אין חלקים ברי טיפול בתוך ההתקן.
- שינויים, שימוש בבקורות או ביצוע הליכים אחרים מאלה המתוארים כאן, עלולים לגרום לחשיפה לקרינה מסוכנת.



סכנה

מוצרי לייזר מסוימים מכילים דיודת לייזר מסוג Class 3A או Class 3B. שימו לב לאזהרה הבאה:  
כאשר הוא פתוח, המוצר פולט קרינת לייזר. אל תביטו ישירות בקרן, אל תביטו ישירות בעזרת ציוד אופטי,  
והימענו מחשיפה לקרן.

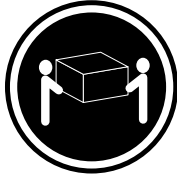

$18 \leq$  ק"ג (37 ליב')



$32 \leq$  ק"ג (70.5 ליב')

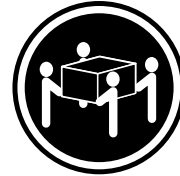

$55 \leq$  ק"ג (121.2 ליב')

זהירות:  
השתמשו בהליכים  
הנאותים בעת  
הרמת הציוד.



זהירות:

לחצן ההפעלה של ההתקן ומתג ההפעלה של ספק החשמל אינם מפסיקים את זרם החשמל המסופק להתקן.  
בנוסף, ההתקן עשוי לכלול יותר מכבל חשמל אחד. כדי לסלק את כל הזרם החשמלי מההתקן,  
ודאו שכל כבלי החשמל מנותקים ממקור החשמל.

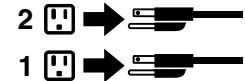

## PERICOLO

La corrente elettrica proveniente dai cavi di alimentazione, del telefono e di comunicazione può essere pericolosa.

**Per evitare il rischio di scosse elettriche:**

- **Non collegare o scollegare qualsiasi cavo oppure effettuare l'installazione, la manutenzione o la riconfigurazione del prodotto durante un temporale.**
- **Collegare tutti i fili elettrici a una presa di alimentazione correttamente cablata e dotata di messa a terra.**
- **Collegare alle prese elettriche appropriate tutte le apparecchiature che verranno utilizzate per questo prodotto.**

- Se possibile, utilizzare solo una mano per collegare o scollegare i cavi di segnale.
- Non accendere assolutamente apparecchiature in presenza di incendi, perdite d'acqua o danno strutturale.
- Scollegare i cavi di alimentazione, i sistemi di telecomunicazione, le reti e il modem prima di aprire i coperchi del dispositivo, salvo istruzioni contrarie relative alle procedure di installazione e configurazione.
- Collegare e scollegare i cavi come descritto nella seguente tabella quando vengono effettuate operazioni di installazione, spostamento o apertura dei coperchi di questo prodotto o delle unità collegate.

Per collegarsi	Per scollegarsi
<ol style="list-style-type: none"> <li>1. SPEGNERE le apparecchiature.</li> <li>2. Innanzitutto, collegare tutti i cavi alle unità.</li> <li>3. Collegare i cavi di segnale ai connettori.</li> <li>4. Collegare i cavi di alimentazione alla presa.</li> <li>5. Accendere l'unità.</li> </ol>	<ol style="list-style-type: none"> <li>1. SPEGNERE le apparecchiature.</li> <li>2. Innanzitutto, rimuovere i cavi di alimentazione dalla presa.</li> <li>3. Rimuovere i cavi di segnale dai connettori.</li> <li>4. Rimuovere tutti i cavi dalle unità.</li> </ol>



#### ATTENZIONE:

Quando si sostituisce la batteria al litio, utilizzare solo il Numero parte 45C1566 o un tipo di batteria equivalente consigliato dal produttore. Se sul sistema è presente un modulo che contiene una batteria al litio, sostituirlo solo con un tipo di modulo dello stesso tipo della stessa casa di produzione. La batteria contiene litio e può esplodere se usata, maneggiata o smaltita in modo non corretto.

*Non:*

- Gettare o immergere la batteria nell'acqua
- Riscaldarla ad una temperatura superiore ai 100 gradi C (212 gradi F)
- Smontarla, ricaricarla o tentare di ripararla

Le batterie usate vanno smaltite in accordo alla normativa in vigore (DPR 915/82 e successive disposizioni e disposizioni locali).



#### ATTENZIONE:

Quando vengono installati prodotti laser (quali CD-ROM, unità DVD-ROM, unità a fibre ottiche o trasmettenti), tener presente quanto segue:

- Non rimuovere gli sportelli. L'apertura di un'unità laser può determinare l'esposizione a radiazioni laser pericolose. All'interno dell'unità non vi sono parti su cui effettuare l'assistenza tecnica.
- L'utilizzo di controlli, regolazioni o l'esecuzione di procedure non descritti nel presente manuale possono provocare l'esposizione a radiazioni pericolose.



## PERICOLO

Alcune unità laser contengono un diodo laser di Classe 3A o Classe 3B. Tener presente quanto segue:

Aperto l'unità vengono emesse radiazioni laser. Non fissare il fascio, non guardarlo direttamente con strumenti ottici ed evitare l'esposizione al fascio.



≥18 kg (37 lbs)



≥32 kg (70.5 lbs)



≥55 kg (121.2 lbs)

## ATTENZIONE:

Prestare attenzione nel sollevare l'apparecchiatura.



## ATTENZIONE:

Il pulsante di controllo dell'alimentazione presente sull'unità e l'interruttore dell'alimentatore non disattivano l'alimentazione corrente fornita all'unità. E' possibile che l'unità disponga di più cavi di alimentazione. Per disattivare l'alimentazione dall'unità, accertarsi che tutti i cavi di alimentazione siano scollegati dalla fonte di alimentazione.



## 위험

전원, 전화, 통신 케이블의 전류는 위험합니다.

감전의 위험을 피하려면 다음과 같이 하십시오.

- 번개가 치는 날에는 케이블을 연결 또는 분리하거나 본 제품을 설치, 보수, 재구성하지 마십시오.
- 모든 전원 코드는 올바르게 접지된 전기 콘센트에 연결하십시오.
- 본 제품에 연결될 장치는 올바르게 배선된 콘센트에 연결하십시오.
- 신호 케이블을 연결 또는 분리할 때 가능하면 한 손만을 사용하십시오.
- 불 또는 물로 인한 손상이나 구조적인 손상이 있을 경우 장치의 전원을 절대 켜지 마십시오.
- 설치 및 구성 과정에 별도의 지시 사항이 없는 경우, 장치의 덮개를 열기 전에 연결된 전원 코드, 원격 통신 시스템, 네트워크, 모뎀을 분리하십시오.
- 본 제품이나 연결된 장치를 설치, 이동하거나 덮개를 열 때 다음 표와 같은 순서로 케이블을 연결하거나 분리하십시오.

연결할 때:	분리할 때:
<ol style="list-style-type: none"><li>1. 모든 장치의 전원을 끄십시오.</li><li>2. 먼저 모든 케이블을 장치에 연결하십시오.</li><li>3. 커넥터에 신호 케이블을 연결하십시오.</li><li>4. 콘센트에 전원 코드를 연결하십시오.</li><li>5. 장치의 전원을 켜십시오.</li></ol>	<ol style="list-style-type: none"><li>1. 모든 장치의 전원을 끄십시오.</li><li>2. 먼저 콘센트에서 전원 코드를 분리하십시오.</li><li>3. 커넥터에서 신호 케이블을 분리하십시오.</li><li>4. 장치에서 모든 케이블을 분리하십시오.</li></ol>



### 주의:

배터리를 교환할 때는 Part Number 45C1566 또는 제조업체에서 지정한 동일한 종류의 제품을 사용하십시오. 사용자의 시스템이 리튬 배터리를 포함하는 모듈일 경우, 동일한 제조업체에서 동일한 모듈 유형으로 생산된 제품으로 교체하십시오. 배터리에는 리튬이 함유되어 있어 잘못 사용, 취급 또는 폐기할 경우 폭발의 위험이 있습니다.

사고를 방지하려면 다음 사항을 준수하십시오.

- 배터리를 물 속에 던지거나 침수시키지 마십시오.
- 100°C (212°F) 이상 가열하지 마십시오.
- 수리하거나 분해하지 마십시오.

배터리를 폐기할 때는 법령 또는 회사의 안전 수칙에 따라 폐기하십시오.



### 주의:

CD-ROM, DVD-ROM 장치, 광섬유 장치 또는 송신 장치와 같은 레이저 제품을 설치할 때, 다음과 같은 취급 주의사항을 참고하십시오.

- 덮개를 열지 마십시오. 덮개를 열면 레이저 복사 에너지에 노출될 위험이 있습니다. 장치 내부에는 사용자가 조정하거나 수리할 수 있는 부품이 없습니다.
- 규정된 것 이외의 절차 수행, 제어 조정 등의 행위로 인해 해로운 레이저 복사에 노출될 수 있습니다.



## 위험

일부 장비에는 임베디드 클래스 3A 또는 클래스 3B 레이저 다이오드가 있습니다. 다음 주의사항에 유의하십시오.

드라이브가 열리면 레이저 복사 에너지가 방출됩니다. 광선이 눈에 직접 쏘이지 않도록 하십시오. 나안 또는 광학 기구를 착용한 상태에서 광선을 직접 바라보지 않도록 하십시오.



≥ 18 kg (37 lbs)



≥ 32 kg (70.5 lbs)



≥ 55 kg (121.2 lbs)

주의:  
제품을 들어 올릴 때  
안전 규제를 따르십시오.



주의:  
장치의 전원 제어 버튼 및 전원 공급 장치의 전원 스위치를 사용하여 장치에 공급되는 전기를 차단하지 마십시오.  
장치는 둘 이상의 코드를 가지고 있을 수 있습니다. 장치에서 모든 전원을 차단하려면 콘센트에서 코드가 모두  
분리되어 있는지 확인하십시오.



## PELIGRO

La corriente eléctrica procedente de cables de alimentación, teléfonos y cables de comunicación puede ser peligrosa.

Para evitar el riesgo de descarga eléctrica:

- No conecte ni desconecte los cables ni realice ninguna tarea de instalación, mantenimiento o reconfiguración de este producto durante una tormenta eléctrica.
- Conecte todos los cables de alimentación a tomas de corriente debidamente cableadas y conectadas a tierra.
- Cualquier equipo que se conecte a este producto también debe conectarse a tomas de corriente debidamente cableadas.
- Siempre que sea posible, utilice una sola mano para conectar o desconectar los cables de señal.
- No encienda nunca un equipo cuando hay señales de fuego, agua o daños estructurales.



- **Desconecte los cables de alimentación, los sistemas de telecomunicaciones, las redes y los módems conectados antes de abrir las cubiertas de los dispositivos, a menos que se indique lo contrario en los procedimientos de instalación y configuración.**
- **Conecte y desconecte los cables, como se describe en la tabla siguiente, cuando instale, mueva o abra las cubiertas de este producto o de los dispositivos conectados.**

Para conectar	Para desconectar
<ol style="list-style-type: none"> <li>1. APÁGUELO todo.</li> <li>2. En primer lugar, conecte todos los cables a los dispositivos.</li> <li>3. Conecte los cables de señal a los conectores.</li> <li>4. Enchufe los cables de alimentación a las tomas de corriente.</li> <li>5. Encienda el dispositivo.</li> </ol>	<ol style="list-style-type: none"> <li>1. APÁGUELO todo.</li> <li>2. En primer lugar, desenchufe los cables de alimentación de las tomas de corriente.</li> <li>3. Desconecte los cables de señal de los conectores.</li> <li>4. Desconecte todos los cables de los dispositivos.</li> </ol>



#### **PRECAUCIÓN:**

Quando sustituya una batería de litio, utilice solamente una batería número de pieza 45C1566 u otra de tipo equivalente recomendada por el fabricante. Si su sistema dispone de un módulo que contiene una batería de litio, reemplácelo sólo con el mismo tipo de módulo, del mismo fabricante. La batería contiene litio y puede explotar si no se utiliza, manipula o desecha correctamente.

*No debe:*

- Arrojarla al agua o sumergirla en ella
- Exponerla a temperaturas superiores a 100°C (212°F)
- Repararla o desmontarla

Deshágase de la batería según especifiquen las leyes o normas locales.



#### **PRECAUCIÓN:**

Quando haya productos láser (como unidades de CD-ROM, unidades de DVD, dispositivos de fibra óptica o transmisores) instalados, tenga en cuenta lo siguiente:

- No quite las cubiertas. Si quita las cubiertas del producto láser, podría quedar expuesto a radiación láser peligrosa. Dentro del dispositivo no existe ninguna pieza que requiera servicio técnico.
- Si usa controles o ajustes o realiza procedimientos que no sean los especificados aquí, podría exponerse a radiaciones peligrosas.



#### **PELIGRO**

Algunos productos láser tienen incorporado un diodo láser de clase 3A o clase 3B. Tenga en cuenta lo siguiente:

Cuando se abre, queda expuesto a radiación láser. No mire directamente al rayo láser, ni siquiera con instrumentos ópticos, y evite exponerse directamente al rayo láser.



≥18 kg (37 lbs)



≥32 kg (70.5 lbs)



≥55 kg (121.2 lbs)

#### PRECAUCIÓN:

Adopte procedimientos seguros al levantar el equipo.



#### PRECAUCIÓN:

El botón de control de alimentación del dispositivo y el interruptor de alimentación de la fuente de alimentación no desconectan la corriente eléctrica suministrada al dispositivo. Además, el dispositivo podría tener más de un cable de alimentación. Para suprimir toda la corriente eléctrica del dispositivo, asegúrese de que todos los cables de alimentación estén desconectados de la toma de corriente.



---

## Chapter 3. General information

This chapter provides general information that applies to all machine types supported by this manual.

---

### Lenovo Welcome

The Lenovo Welcome program introduces you to some innovative built-in features of Lenovo and guides you through a few important setup tasks to help you make the most of your computer.

---

### Lenovo ThinkVantage Tools

The Lenovo ThinkVantage Tools program guides you to a host of information sources and provides easy access to various tools to help you work more easily and securely.

**Note:** The Lenovo ThinkVantage Tools program is only available on computers preinstalled with the Windows 7 operating system from Lenovo.

To access the Lenovo ThinkVantage Tools program, click **Start → All Programs → Lenovo ThinkVantage Tools**.

Table 1. Program icon names in Lenovo ThinkVantage Tools

Program name	Icon name in Lenovo ThinkVantage Tools
Create Recovery Media	Factory Recovery Disks
Fingerprint Software	Fingerprint Reader
Lenovo ThinkVantage Toolbox	System Health and Diagnostics
ThinkVantage Password Manager	Password Vault
ThinkVantage Power Manager	Power Controls
ThinkVantage Rescue and Recovery®	Enhanced Backup and Restore
ThinkVantage System Update	Update and Drives

---

### Lenovo ThinkVantage Toolbox

The Lenovo ThinkVantage Toolbox program helps you maintain your computer, improve computing security, diagnose computer problems, get familiar with the innovative technologies provided by Lenovo, and get more information about your computer. See “Lenovo ThinkVantage Toolbox” on page 37 for detailed information.

---

### ThinkVantage Productivity Center

The ThinkVantage Productivity Center program contains information sources and tools designed to make computing easy and secure. It provides easy access to various technologies, such as:

- Client Security Solution
- Power Manager
- Productivity Center
- Product Recovery
- Rescue and Recovery
- System Update

**Note:** The ThinkVantage Productivity Center program is only available on computers preinstalled with the Windows Vista operating system from Lenovo.

To access the ThinkVantage Productivity Center program, click **Start → All Programs → ThinkVantage → Productivity Center**.

---

## **Additional information resources**

If you have Internet access, the most up-to-date information for your computer is available at:  
<http://www.lenovo.com/support>

You can find the following information:

- CRU removal and installation instructions
- Downloads and drivers
- Parts information
- Publications
- Troubleshooting information
- Links to other useful sources of information

---

## Specifications

This section lists the physical specifications for your computer.

### Dimensions

Width: 275 mm (10.83 inches)

Height: 79 mm (3.11 inches)

Depth: 238 mm (9.37 inches)

### Weight

Maximum configuration as shipped: 4.18 kg (9.22 lb)

### Environment

- Air temperature:
  - Operating: 10°C to 35°C (50°F to 95°F)
  - Non-operating: -40°C to 60°C (-40°F to 140°F)
  - Non-operating: -10°C to 60°C (14°F to 140°F) (without package)
- Humidity:
  - Operating: 20% to 80% (non-condensing)
  - Non-operating: 20% to 90% (non-condensing)
- Altitude:
  - Operating: -50 to 10 000 ft (-15.2 to 3 048 m)
  - Non-operating: -50 to 35 000 ft (-15.2 to 10 668 m)

### Electrical input

- Input voltage:
  - Low range:
    - Minimum: 100 V ac
    - Maximum: 127 V ac
    - Input frequency range: 50 to 60 Hz
  - High range:
    - Minimum: 200 V ac
    - Maximum: 240 V ac
    - Input frequency range: 50 to 60 Hz



---

## Chapter 4. General checkout

### Attention

The drives in the computer you are servicing might have been rearranged or the drive startup sequence changed. Be extremely careful during write operations such as copying, saving, or formatting. Data or programs can be overwritten if you select an incorrect drive.

General error messages appear if a problem or conflict is found by an application program, the operating system, or both. For the explanation of these messages, refer to the information supplied with that software package.

Before replacing any FRUs, ensure that the latest level of BIOS is installed on the system. A down-level BIOS might cause false errors and unnecessary replacement of the system board. For more information on how to determine and obtain the latest level BIOS, see “BIOS levels” on page 179.

**Notes:** For computer models that do not have an internal hard disk drive and use a remote hard disk drive accessed through the Secure Managed Client - Storage Array (SMC - Storage Array):

- You might receive the error message “No operating system found. Press F1 to repeat boot sequence.” In this case, press Ctrl+Alt+Delete instead of F1 to establish a connection to the storage area network where your operating system is stored. Verify that the user name is not logged on in another location.
- If the SMC login prompt disappears before you log in and then a black screen displays, contact your administrator.

Use the following procedure to help determine the cause of a problem:

1. Turn off the computer and all external devices.
2. Check all cables and power cords.
3. Set all display controls to the middle position.
4. Turn on all external devices.
5. Turn on the computer.
  - Look for displayed error codes
  - Listen for beep codes
  - Look for readable instructions or a main menu on the display.If you *did not* receive the correct response, proceed to step 6 on page 33.

If you *do* receive the correct response, run the diagnostics. See “Running the diagnostic program from a diagnostic disc” on page 38.

6. Look at the following conditions and follow the instructions:
  - If you hear beep codes during POST, go to “Beep symptoms” on page 63.
  - If the computer displays a POST error, go to “POST error codes” on page 63.
  - If the computer hangs and no error is displayed, go to “Power problems” on page 33.

---

## Checking for power problems

If the computer does not turn on when the power switch is pressed, use the following procedure to help troubleshoot:

1. Press the power switch to turn on the computer. Check the power indicator LED next to the power switch.
  - If the LED is illuminated (on), the computer power is OK. Attempt to run the diagnostics. See “Running the diagnostic program from a diagnostic disc” on page 38.

- If the LED is not illuminated (off), go to step 2 on page 34
- 2. Check the status of the power indicator LED on the AC/DC power adapter.
  - If the LED is illuminated (on), go to step 7 on page 34.
  - If the LED is not illuminated (off), go to the next step 3 on page 34.
- 3. Verify that the power cord is properly connected to an AC power outlet.
- 4. Verify that you are using a good AC power outlet. Plug another device into the outlet or contact the power company or supplier to verify that the outlet is working correctly .
- 5. Check the power cord continuity.
- 6. Replace the AC/DC power adapter.
- 7. Verify that the power cord from the AC/DC power adapter to the computer is properly connected. See “Locating connectors on the rear of your computer” on page 70.
- 8. Open the cover. See “Opening the computer cover” on page 72.
- 9. Check the power switch/LED assembly connector on the system board. See “Locating parts on the system board” on page 71. Reseat the cable from the power switch/LED assembly to the system board.
- 10. Replace the power switch/LED assembly.
- 11. Replace the system board. See “Replacing the system board” on page 86.

---

## Problem determination tips

Due to the variety of hardware and software combinations that can be encountered, use the following information to assist you in problem determination. If possible, have this information available when requesting assistance from Service Support and Engineering functions.

- Machine type and model
- Processor or hard disk drive upgrades
- Failure symptom
  - Do diagnostics indicate a failure?
  - What, when, where, single, or multiple systems?
  - Is the failure repeatable?
  - Has this configuration ever worked?
  - If it has been working, what changes were made prior to it failing?
  - Is this the original reported failure?
- Diagnostics version
  - Type and version level
- Hardware configuration
  - Print (print screen) configuration currently in use
  - BIOS level
- Operating system software
  - Type and version level

**Notes:** To eliminate confusion, identical systems are considered identical only if they:

1. Are the exact machine type and models
2. Have the same BIOS level
3. Have the same adapters/attachments in the same locations
4. Have the same address jumpers/terminators/cabling



5. Have the same software versions and levels
6. Have the same diagnostic diskettes (version)
7. Have the same configuration options set in the system
8. Have the same setup for operating-system-controlled files

Comparing the configuration and software setup between “working and non-working” systems will often lead to problem resolution.



---

## Chapter 5. Diagnostics

Diagnostic programs are used to test hardware components of your computer. Diagnostic programs can also report operating-system-controlled settings that interfere with the correct operation of your computer. You can use the preinstalled Lenovo ThinkVantage Toolbox program to diagnose computer problems, if your computer is running the Windows operating system.

### Notes:

1. You can also download the PC-Doctor for DOS diagnostic program from <http://www.lenovo.com/support>. See “PC-Doctor for DOS” on page 37 for detailed information.
2. If you are unable to isolate and repair the problem yourself after running the programs, save and print the log files created by the programs. You will need the log files when you speak to a Lenovo technical support representative.

---

## Lenovo ThinkVantage Toolbox

The Lenovo ThinkVantage Toolbox program helps you maintain your computer, improve computing security, diagnose computer problems, get familiar with the innovative technologies provided by Lenovo, and get more information about your computer. You can use the diagnostics feature of the Lenovo ThinkVantage Toolbox program to test devices, diagnose computer problems, create bootable diagnostic media, update system drivers, and view system information.

- To run the Lenovo ThinkVantage Toolbox program on the Windows 7 operating system, click **Start → All Programs → Lenovo ThinkVantage Tools → System Health and Diagnostics**. Follow the instructions on the screen.
- To run the Lenovo ThinkVantage Toolbox program on the Windows Vista operating system, click **Start → All Programs → ThinkVantage → Lenovo ThinkVantage Toolbox**. Follow the instructions on the screen.

Follow the instructions on the screen. For additional information, refer to the Lenovo ThinkVantage Toolbox help system.

---

## PC-Doctor for DOS

You can also download the latest version of the PC-Doctor for DOS diagnostic program from <http://www.lenovo.com/support>. The PC-Doctor for DOS diagnostic program runs independently of the Windows operating system. Use the PC-Doctor for DOS diagnostic program if you are unable to start the Windows operating system or if the two diagnostic programs preinstalled on your computer have not been successful in isolating a possible problem. You can run the PC-Doctor for DOS diagnostic program from a diagnostic disc that you created.

## Creating a diagnostic disc

This section provides instructions on how to create a diagnostic disc.

To create a diagnostic disc, do the following:

1. Download a self-starting bootable CD/DVD image (known as an ISO image) of the diagnostic program from:  
<http://www.lenovo.com/support>
2. Use any CD/DVD burning software to create a diagnostic disc with the ISO image.

## Running the diagnostic program from a diagnostic disc

This section provides instructions on how to run the diagnostic program from a diagnostic disc that you created.

To run the diagnostic program from a diagnostic disc that you created, do the following:

1. Make sure the optical drive you want to use is set as the first boot device in the startup device sequence. See “Selecting a startup device” on page 44.
2. Make sure the computer is turned on and then insert the disc into the optical drive. The diagnostic program opens.

**Note:** You can insert the disc into the optical drive when you are setting the startup device sequence. However, if you insert the disc into the optical drive when you have already entered the operating system, you need to restart the computer to access the diagnostic program.

3. Follow the instructions on the screen to select the diagnostic test you want to run.

**Note:** For additional help, press the F1 key.

4. Remove the diagnostic disc from the optical drive when you complete the diagnostic process.

## Navigating through the diagnostics programs

Use the cursor movement keys to navigate within the menus.

- The Enter key is used to select a menu item.
- The Esc key is used to back up to the previous menu.
- For online help, select F1.

## Running tests

There are four ways to run the diagnostic tests.

- Using the cursor movement keys, highlight **Run Normal Test** or **Run Quick Test** from the Diagnostics menu and then press Enter. This automatically runs a pre-defined group of tests from each test category. **Run Normal Test** runs a more extensive set of tests than **Run Quick Test** does and takes longer to complete.
- Press F5 to automatically run all selected tests in all categories.
- From within a test category, press Ctrl+Enter to automatically run only the selected tests in that category.
- Using the cursor movement keys, highlight a single test within a test category, and then press Enter. This runs only that test.

Press Esc at any time to stop the testing process.

Test results (N/A, PASSED, FAILED, ABORTED) are displayed in the field beside the test description and in the test log. See “Viewing the test log” on page 40.

To select one or more tests, use the following procedure.

1. Open the corresponding test category.
2. Using the cursor movement keys, highlight the desired test.
3. Press the space bar. A selected test is marked by >>. Pressing the space bar again de-selects a test and removes the >>.
4. Repeat steps 2 and 3 above to select all desired tests.

## Test results

Diagnostics test results produce the following error code format:

Function Code	Failure Type	DeviceID	Date	ChkDigits	Text
---------------	--------------	----------	------	-----------	------

- **Function Code:**  
Represents the feature or function within the PC.
- **Failure Type:**  
Represents the type of error encountered.
- **DeviceID:**  
Contains the component's unit-ID which corresponds to either a fixed disk drive, removable media drive, processor, specific RIMM, or a device on the PCI bus.
- **Date:**  
Contains the date when the diagnostic test was run. The date is retrieved from CMOS and displayed using the YYYYMMDD format.
- **ChkDigits:**  
Contains a 2-digit check-digit value to ensure the following:
  - Diagnostics were run on the specified date.
  - Diagnostics were run on the specified computer.
  - The diagnostic error code is recorded correctly.
- **Text:**  
Description of the error.

**Note:** See “Diagnostic error codes” on page 47 for error code listings.

## Quick and Full erase - hard drive

The diagnostics program offers two hard drive format utilities:

- Quick Erase Hard Drive
- Full Erase Hard Drive

The Quick Erase Hard Drive provides a DOS utility that performs the following:

- Destroys the Master Boot Record (MBR) on the hard drive.
- Destroys all copies of the FAT Table on all partitions (both the master and backup).
- Destroys the partition table.
- Provides messages that warn the user that this is a non-recoverable process.

The Full Erase Hard Drive provides a DOS utility that performs the following:

- Performs all the steps in Quick Erase.
- Provides a DOS utility that writes random data to all sectors of the hard drive.
- Provides an estimate of time to completion along with a visual representation of completion status.
- Provides messages that warn the user about non-recoverable process.

<b>Important:</b> Make sure that all data is backed up before using the Quick or Full Erase functions.
--

To select the Quick Erase Hard drive or Full Erase Hard Drive utility, do the following:

1. Select the **UTILITY** option on the toolbar and press Enter.
2. Select either the **QUICK ERASE** or **FULL ERASE HARD DISK** option and follow the instructions.

## Viewing the test log

Errors reported by the diagnostic test will be displayed by the program as a failed test.

To view details of a failure or to view a list of test results, use the following procedure from any test category screen:

1. Press F3 to activate the log file.
2. Press F3 again to save the file to diskette or press F2 to print the file.

---

## Chapter 6. Using the Setup Utility program

The Setup Utility program is used to view and change the configuration settings of your computer, regardless of which operating system you are using. However, the operating system settings might override any similar settings in the Setup Utility program.

---

### Starting the Setup Utility program

To start the Setup Utility program, do the following:

1. Make sure your computer is turned off.
2. Repeatedly press and release the F1 key when turning on the computer. When you hear multiple beeps or see a logo screen, release the F1 key.

**Note:** If a Power-On Password or an Administrator Password has been set, the Setup Utility program menu will not be displayed until you type the correct password. For more information, see “Using passwords” on page 41.

When the POST detects that the hard disk drive has been removed from your computer or the memory module size has decreased, an error message will be displayed when you start the computer and you will be prompted to do one of the following:

- Press F1 to enter the Setup Utility program.

**Note:** After you enter the Setup Utility program, select **Save Changes and Exit** at the bottom of the screen. The error message will not be displayed again.

- Press F2 to bypass the error message and log in to the operating system.

---

### Viewing and changing settings

The Setup Utility program menu lists various items about the system configuration. To view or change settings, start the Setup Utility program. See “Starting the Setup Utility program” on page 41. Then, follow the instructions on the screen.

You can use either the keyboard or the mouse to navigate through BIOS menu choices. The keys used to perform various tasks are displayed at the bottom of each screen.

---

### Using passwords

By using the Setup Utility program, you can set passwords to prevent unauthorized access to your computer and data. The following types of passwords are available:

- Power-On Password
- Administrator Password
- Hard Disk Password

You do not have to set any passwords to use your computer. However, using passwords improves computing security. If you decide to set any passwords, read the following sections.

## Password considerations

A password can be any combination of up to 64 alphabetic and numeric characters. For security reasons, it is recommended to use a strong password that cannot be easily compromised. To set a strong password, use the following guidelines:

- Have at least eight characters in length
- Contain at least one alphabetic character and one numeric character
- Setup Utility program and hard disk drive passwords are not case sensitive
- Not be your name or your user name
- Not be a common word or a common name
- Be significantly different from your previous passwords

## Power-On Password

When a Power-On Password is set, you are prompted to type a valid password each time the computer is turned on. The computer cannot be used until the valid password is typed in.

## Administrator Password

Setting an Administrator Password deters unauthorized users from changing configuration settings. If you are responsible for maintaining the configuration settings of several computers, you might want to set an Administrator Password.

When an Administrator Password is set, you are prompted to type a valid password each time you try to access the Setup Utility program. The Setup Utility program cannot be accessed until a valid password is typed in.

If both the Power-On Password and Administrator Password are set, you can type either password. However, you must use your Administrator Password to change any configuration settings.

## Hard Disk Password

Setting a Hard Disk Password prevents unauthorized access to the data on the hard disk drive. When a Hard Disk Password is set, you are prompted to type a valid password each time you try to access the hard disk drive.

### Notes:

- After you set a Hard Disk Password, your data on the hard disk drive is protected even if the hard disk drive is removed from one computer and installed in another.
- If the Hard Disk Password is forgotten, there is no way to reset the password or recover data from the hard disk drive.

## Setting, changing, and deleting a password

To set, change, or delete a password, do the following:

1. Start the Setup Utility program. See “Starting the Setup Utility program” on page 41.
2. From the Setup Utility program main menu, select **Security**.
3. Depending on the password type, select **Set Power-On Password**, **Set Administrator Password**, or **Hard Disk Password**.
4. Follow the instructions on the right side of the screen to set, change, or delete a password.



**Note:** A password can be any combination of up to 64 alphabetic and numeric characters. For more information, see “Password considerations” on page 42.

## Erasing lost or forgotten passwords (clearing CMOS)

This section provides instructions on how to erase lost or forgotten passwords, such as a user password.

To erase a lost or forgotten password, do the following:

1. Remove all media from the drives and turn off all attached devices and the computer. Then, disconnect all power cords from electrical outlets and disconnect all cables that are connected to the computer.
2. Open the computer cover. See “Opening the computer cover” on page 72.
3. Locate the Clear CMOS /Recovery jumper on the system board. See “Locating parts on the system board” on page 71.
4. Move the jumper from the standard position (pin 1 and pin 2) to the maintenance position (pin 2 and pin 3).
5. Close the computer cover and connect the power cord. See “Completing the parts replacement” on page 98.
6. Turn on the computer and leave it on for approximately 10 seconds. Then, turn off the computer by holding the power switch for approximately five seconds.
7. Repeat step 1 through step 2.
8. Move the Clear CMOS /Recovery jumper back to the standard position (pin 1 and pin 2).
9. Close the computer cover and connect the power cord. See “Completing the parts replacement” on page 98.

---

## Enabling or disabling a device

This section provides information on how to enable or disable user access to the following devices:

<b>USB Setup</b>	Use this option to enable or disable a USB connector. When a USB connector is disabled, the device connected to the USB connector cannot be used.
<b>SATA Controller</b>	When this feature is set to <b>Disable</b> , all devices connected to the SATA connectors (such as hard disk drives or the optical drive) are disabled and cannot be accessed.
<b>External SATA Port</b>	When this option is set to <b>Disable</b> , the device connected to the External SATA connector cannot be accessed.

To enable or disable a device, do the following:

1. Start the Setup Utility program. See “Starting the Setup Utility program” on page 41.
2. From the Setup Utility program main menu, select **Devices**.
3. Depending on the device you want to enable or disable, do one of the following:
  - Select **USB Setup** to enable or disable a USB device.
  - Select **ATA Drive Setup** to enable or disable an internal or external SATA device.
4. Select the desired settings and press Enter.
5. Press F10 to save and exit the Setup Utility program. See “Exiting from the Setup Utility program” on page 45.

---

## Selecting a startup device

If your computer does not start up from a device such as the disc or hard disk drive as expected, do one of the following to select the startup device you want.

## Selecting a temporary startup device

Use this procedure to select a temporary startup device.

**Note:** Not all discs and hard disk drives are bootable.

1. Turn off your computer.
2. Repeatedly press and release the F12 key when turning on the computer. When the Please select boot device window displays, release the F12 key.
3. Select the desired startup device and press Enter. The computer will start up from the device you selected.

**Note:** Selecting a startup device from the Please select boot device window does not permanently change the startup sequence.

## Selecting or changing the startup device sequence

To view or permanently change the configured startup device sequence, do the following:

1. Start the Setup Utility program. See “Starting the Setup Utility program” on page 41.
2. From the Setup Utility program main menu, select **Startup**.
3. Select the devices for the Primary Startup Sequence, the Automatic Startup Sequence, and the Error Startup Sequence. Read the information displayed on the right side of the screen.
4. Press F10 to save and exit the Setup Utility program. See “Exiting from the Setup Utility program” on page 45.

---

## Smart performance choices

You can adjust the acoustic and thermal performance of your computer through the **Smart Performance Choice** menu. Two choices are available:

- **Better Acoustic Performance** (default choice)
- **Better Thermal Performance**

By enabling **Better Acoustic Performance**, your computer will run with less noise at a normal thermal level. By enabling **Better Thermal Performance**, your computer will run at a better thermal level with normal acoustic performance.

To switch between better acoustic performance and better thermal performance, do the following:

1. Start the Setup Utility program. See “Starting the Setup Utility program” on page 41.
2. From the Setup Utility program main menu, select **Power**.
3. Select **Smart Performance Choice**. The Smart Performance Choice window is displayed.
4. Select **Better Acoustic Performance** or **Better Thermal Performance** as desired.
5. Press F10 to save your setting and exit the Setup Utility program. See “Exiting from the Setup Utility program” on page 45.

---

## Exiting from the Setup Utility program

After you finish viewing or changing settings, press Esc to return to the Setup Utility program main menu. You might have to press Esc several times. Do one of the following:

- If you want to save the new settings, press F10 to save and exit the Setup Utility program.
- If you do not want to save the settings, select **Exit → Discard Changes and Exit**.
- If you want to return to the default settings, press F9 to load the default settings.



---

## Chapter 7. Symptom-to-FRU index

The Symptom-to-FRU index lists error symptoms and possible causes. The most likely cause is listed first. Always begin with the Chapter 4 “General checkout” on page 33. You can use this index to help you decide which FRUs are needed when servicing a computer. If you are unable to correct the problem using this index, go to “Undetermined problems” on page 66.

### Notes:

1. If you have both an error message and an incorrect audio response, diagnose the error message first.
2. If you cannot run the diagnostic tests or you get a diagnostic error code when running a test, but did receive a POST error message, diagnose the POST error message first.
3. If you did not receive any error message, look for a description of your error symptoms in the first part of this index.
4. For computer models that do not have an internal hard disk drive and use a remote hard disk drive accessed through the SMC - Storage Array:
  - You might receive the error message “No operating system found. Press F1 to repeat boot sequence.” In this case, press Ctrl+Alt+Delete instead of F1 to establish a connection to the storage area network where your operating system is stored. Verify that the user name is not logged on in another location.
  - If the SMC login prompt disappears before you log in and then a black screen displays, contact the administrator.

---

### Hard disk drive boot error

A hard disk drive boot error (error codes 1962 and I999030X) can have the following causes.

**Note:** For computer models that do not have an internal hard disk drive and use a remote hard disk drive accessed through the SMC - Storage Array, contact the network or storage administrator.

Error	FRU/Action
The start-up drive is not in the boot sequence in configuration.	Check the configuration and ensure the start-up drive is in the boot sequence.
No operating system installed on the boot drive.	Install an operating system on the boot drive.
The boot sector on the start-up drive is corrupted.	The drive must be formatted. Do the following: <ol style="list-style-type: none"><li>1. Attempt to back-up the data on the failing hard disk drive.</li><li>2. Using the operating system programs, format the hard disk drive.</li></ol>
The drive is defective.	Replace the hard disk drive.

---

### Diagnostic error codes

Refer to the following diagnostic error codes when using the diagnostic tests. See “Running tests” on page 38 for the specific type for information about the diagnostic programs.

In the following index, X can represent any number.

<b>Diagnostic Error Code</b>	<b>FRU/Action</b>
<b>000-000-XXX</b> BIOS Test Passed	<b>No action</b>
<b>000-002-XXX</b> BIOS Timeout	<ol style="list-style-type: none"> <li>1. Flash the system. See “Updating (flashing) the BIOS from a disc” on page 180.</li> <li>2. System board</li> </ol>
<b>000-024-XXX</b> BIOS Addressing test failure	<ol style="list-style-type: none"> <li>1. Flash the system. See “Updating (flashing) the BIOS from a disc” on page 180.</li> <li>2. System board</li> </ol>
<b>000-025-XXX</b> BIOS Checksum Value error	<ol style="list-style-type: none"> <li>1. Flash the system. See “Updating (flashing) the BIOS from a disc” on page 180.</li> <li>2. System board</li> </ol>
<b>000-026-XXX</b> FLASH data error	<ol style="list-style-type: none"> <li>1. Flash the system. See “Updating (flashing) the BIOS from a disc” on page 180.</li> <li>2. System board</li> </ol>
<b>000-027-XXX</b> BIOS Configuration/Setup error	<ol style="list-style-type: none"> <li>1. Run the Setup Utility program.</li> <li>2. Flash the system. See “Updating (flashing) the BIOS from a disc” on page 180.</li> <li>3. System board</li> </ol>
<b>000-034-XXX</b> BIOS Buffer Allocation failure	<ol style="list-style-type: none"> <li>1. Reboot the system.</li> <li>2. Flash the system. See “Updating (flashing) the BIOS from a disc” on page 180.</li> <li>3. Run memory test</li> <li>4. System board</li> </ol>
<b>000-035-XXX</b> BIOS Reset Condition detected	<ol style="list-style-type: none"> <li>1. Flash the system. See “Updating (flashing) the BIOS from a disc” on page 180.</li> <li>2. System board</li> </ol>
<b>000-036-XXX</b> BIOS Register error	<ol style="list-style-type: none"> <li>1. Flash the system. See “Updating (flashing) the BIOS from a disc” on page 180.</li> <li>2. System board</li> </ol>
<b>000-038-XXX</b> BIOS Extension failure	<ol style="list-style-type: none"> <li>1. Flash the system. See “Updating (flashing) the BIOS from a disc” on page 180.</li> <li>2. Adapter card</li> <li>3. System board</li> </ol>
<b>000-039-XXX</b> BIOS DMI data error	<ol style="list-style-type: none"> <li>1. Flash the system. See “Updating (flashing) the BIOS from a disc” on page 180.</li> <li>2. System board</li> </ol>
<b>000-195-XXX</b> BIOS Test aborted by user	Information only Restart the test, if necessary.
<b>000-196-XXX</b> BIOS test halt, error threshold exceeded	<ol style="list-style-type: none"> <li>1. Press F3 to review the log file.</li> <li>2. Restart the test to reset the log file.</li> </ol>
<b>000-197-XXX</b> BIOS test warning	<ol style="list-style-type: none"> <li>1. Make sure the component that is called out is connected and/or enabled. See Chapter 6 “Using the Setup Utility program” on page 41.</li> <li>2. Re-run test.</li> <li>3. Replace the component that is called out in warning statement.</li> <li>4. Replace the component under test.</li> </ol>

<b>Diagnostic Error Code</b>	<b>FRU/Action</b>
<b>000-198-XXX</b> BIOS test aborted	<ol style="list-style-type: none"> <li>1. Make sure the component that is called out is connected and/or enabled. See Chapter 6 “Using the Setup Utility program” on page 41.</li> <li>2. Flash the system and re-test. See “Updating (flashing) the BIOS from a disc” on page 180.</li> <li>3. Go to “Undetermined problems” on page 66.</li> </ol>
<b>000-199-XXX</b> BIOS test failed, cause unknown	<ol style="list-style-type: none"> <li>1. Go to “Undetermined problems” on page 66.</li> <li>2. Flash the system and re-test.</li> <li>3. Replace component under function test.</li> </ol>
<b>000-250-XXX</b> BIOS APM failure	<ol style="list-style-type: none"> <li>1. Flash the system. See “Updating (flashing) the BIOS from a disc” on page 180.</li> <li>2. System board</li> </ol>
<b>000-270-XXX</b> BIOS ACPI failure	<ol style="list-style-type: none"> <li>1. Flash the system. See “Updating (flashing) the BIOS from a disc” on page 180.</li> <li>2. System board</li> </ol>
<b>001-000-XXX</b> System Test Passed	No action
<b>001-00X-XXX</b> System Error	System board
<b>001-01X-XXX</b> System Error	System board
<b>001-024-XXX</b> System Addressing test failure	System board
<b>001-025-XXX</b> System Checksum Value error	<ol style="list-style-type: none"> <li>1. Flash the system. See “Updating (flashing) the BIOS from a disc” on page 180.</li> <li>2. System board</li> </ol>
<b>001-026-XXX</b> System FLASH data error	<ol style="list-style-type: none"> <li>1. Flash the system. See “Updating (flashing) the BIOS from a disc” on page 180.</li> <li>2. System board</li> </ol>
<b>001-027-XXX</b> System Configuration/Setup error	<ol style="list-style-type: none"> <li>1. Run the Setup Utility program.</li> <li>2. Flash the system. See “Updating (flashing) the BIOS from a disc” on page 180.</li> <li>3. System board</li> </ol>
<b>001-032-XXX</b> System Device Controller failure	System board
<b>001-034-XXX</b> System Device Buffer Allocation failure	<ol style="list-style-type: none"> <li>1. Reboot the system</li> <li>2. Flash the system. See “Updating (flashing) the BIOS from a disc” on page 180.</li> <li>3. Run memory test</li> <li>4. System board</li> </ol>
<b>001-035-XXX</b> System Device Reset condition detected	System board
<b>001-036-XXX</b> System Register error	System board
<b>001-038-XXX</b> System Extension failure	<ol style="list-style-type: none"> <li>1. Adapter card</li> <li>2. System board</li> </ol>
<b>001-039-XXX</b> System DMI data structure error	<ol style="list-style-type: none"> <li>1. Flash the system. See “Updating (flashing) the BIOS from a disc” on page 180.</li> <li>2. System board</li> </ol>
<b>001-040-XXX</b> System IRQ failure	<ol style="list-style-type: none"> <li>1. Turn off/on the system and re-test.</li> <li>2. System board</li> </ol>

<b>Diagnostic Error Code</b>	<b>FRU/Action</b>
<b>001-041-XXX</b> System DMA failure	<ol style="list-style-type: none"> <li>1. Turn off/on the system and re-test.</li> <li>2. System board</li> </ol>
<b>001-195-XXX</b> System Test aborted by user	Information only Restart the test, if necessary.
<b>001-196-XXX</b> System test halt, error threshold exceeded	<ol style="list-style-type: none"> <li>1. Press F3 to review the log file.</li> <li>2. Restart the test to reset the log file.</li> </ol>
<b>001-197-XXX</b> System test warning	<ol style="list-style-type: none"> <li>1. Make sure the component that is called out is connected and/or enabled. See Chapter 6 "Using the Setup Utility program" on page 41.</li> <li>2. Re-run test</li> <li>3. Replace the component that is called out in warning statement.</li> <li>4. Replace the component under test.</li> </ol>
<b>001-198-XXX</b> System test aborted	<ol style="list-style-type: none"> <li>1. If a component is called out, make sure it is connected and/or enabled. See Chapter 6 "Using the Setup Utility program" on page 41.</li> <li>2. Flash the system and re-test. See "Updating (flashing) the BIOS from a disc" on page 180.</li> <li>3. Go to "Undetermined problems" on page 66.</li> </ol>
<b>001-199-XXX</b> System test failed, cause unknown	<ol style="list-style-type: none"> <li>1. Go to "Undetermined problems" on page 66.</li> <li>2. Flash the system and re-test.</li> <li>3. Replace component under function test.</li> </ol>
<b>001-250-XXX</b> System ECC error	System board
<b>001-254-XXX 001-255-XXX 001-256-XXX 001-257-XXX</b> System DMA error	System board
<b>001-260-XXX 001-264-XXX</b> System IRQ error	System board
<b>001-268-XXX</b> System IRQ1 failure	<ol style="list-style-type: none"> <li>1. Device on IRQ1</li> <li>2. System board</li> </ol>
<b>001-269-XXX</b> System IRQ2 failure	<ol style="list-style-type: none"> <li>1. Device on IRQ2</li> <li>2. System board</li> </ol>
<b>001-270-XXX</b> System IRQ3 failure	<ol style="list-style-type: none"> <li>1. Device on IRQ3</li> <li>2. System board</li> </ol>
<b>001-271-XXX</b> System IRQ4 failure	<ol style="list-style-type: none"> <li>1. Device on IRQ4</li> <li>2. System board</li> </ol>
<b>001-272-XXX</b> System IRQ5 failure	<ol style="list-style-type: none"> <li>1. Device on IRQ5</li> <li>2. System board</li> </ol>
<b>001-273-XXX</b> System IRQ6 (diskette drive) failure	<ol style="list-style-type: none"> <li>1. Diskette Cable</li> <li>2. Diskette drive</li> <li>3. System board</li> </ol>
<b>001-274-XXX</b> System IRQ7 failure	<ol style="list-style-type: none"> <li>1. Device on IRQ7</li> <li>2. System board</li> </ol>
<b>001-275-XXX</b> System IRQ8 failure	<ol style="list-style-type: none"> <li>1. Device on IRQ8</li> <li>2. System board</li> </ol>



<b>Diagnostic Error Code</b>	<b>FRU/Action</b>
<b>001-276-XXX</b> System IRQ9 failure	<ol style="list-style-type: none"> <li>1. Device on IRQ9</li> <li>2. System board</li> </ol>
<b>001-277-XXX</b> System IRQ10 failure	<ol style="list-style-type: none"> <li>1. Device on IRQ10</li> <li>2. System board</li> </ol>
<b>001-278-XXX</b> System IRQ11 failure	<ol style="list-style-type: none"> <li>1. Device on IRQ11</li> <li>2. System board</li> </ol>
<b>001-279-XXX</b> System IRQ12 failure	<ol style="list-style-type: none"> <li>1. Device on IRQ12</li> <li>2. System board</li> </ol>
<b>001-280-XXX</b> System IRQ13 failure	<ol style="list-style-type: none"> <li>1. Device on IRQ13</li> <li>2. System board</li> </ol>
<b>001-281-XXX</b> System IRQ14 (hard disk drive) failure	<ol style="list-style-type: none"> <li>1. Hard disk drive cable</li> <li>2. Hard disk drive</li> <li>3. System board</li> </ol>
<b>001-282-XXX</b> System IRQ15 failure	<ol style="list-style-type: none"> <li>1. Device on IRQ15</li> <li>2. System board</li> </ol>
<b>001-286-XXX 001-287-XXX 001-288-XXX</b> System Timer failure	System board
<b>001-292-XXX</b> System CMOS RAM error	<ol style="list-style-type: none"> <li>1. Run the Setup and Utility program and re-test.</li> <li>2. System board</li> </ol>
<b>001-293-XXX</b> System CMOS Battery	<ol style="list-style-type: none"> <li>1. CMOS Battery</li> <li>2. System board</li> </ol>
<b>001-298-XXX</b> System RTC date/time update failure	<ol style="list-style-type: none"> <li>1. Flash the system. See "Updating (flashing) the BIOS from a disc" on page 180.</li> <li>2. System board</li> </ol>
<b>001-299-XXX</b> System RTC periodic interrupt failure	System board
<b>001-300-XXX</b> System RTC Alarm failure	System board
<b>001-301-XXX</b> System RTC Century byte error	<ol style="list-style-type: none"> <li>1. Flash the system. See "Updating (flashing) the BIOS from a disc" on page 180.</li> <li>2. System board</li> </ol>
<b>005-000-XXX</b> Video Test Passed	No action
<b>005-00X-XXX</b> Video error	<ol style="list-style-type: none"> <li>1. Video card, if installed</li> <li>2. System board</li> </ol>
<b>005-010-XXX 005-011-XXX 005-012-XXX 005-013-XXX</b> Video Signal failure	<ol style="list-style-type: none"> <li>1. Video card, if installed</li> <li>2. System board</li> </ol>
<b>005-016-XXX</b> Video Simple Pattern test failure	<ol style="list-style-type: none"> <li>1. Video Ram</li> <li>2. Video card, if installed</li> <li>3. System board</li> </ol>
<b>005-024-XXX</b> Video Addressing test failure	<ol style="list-style-type: none"> <li>1. Video card, if installed</li> <li>2. System board</li> </ol>
<b>005-025-XXX</b> Video Checksum Value error	<ol style="list-style-type: none"> <li>1. Video card, if installed</li> <li>2. System board</li> </ol>

<b>Diagnostic Error Code</b>	<b>FRU/Action</b>
<b>005-027-XXX</b> Video Configuration/Setup error	<ol style="list-style-type: none"> <li>1. Run the Setup Utility program.</li> <li>2. Video drivers update</li> <li>3. Video card, if installed</li> <li>4. System board</li> </ol>
<b>005-031-XXX</b> Video Device Cable failure	<ol style="list-style-type: none"> <li>1. Video cable</li> <li>2. Monitor</li> <li>3. Video card, if installed</li> <li>4. System board</li> </ol>
<b>005-032-XXX</b> Video Device Controller failure	<ol style="list-style-type: none"> <li>1. Video card, if installed</li> <li>2. System board</li> </ol>
<b>005-036-XXX</b> Video Register error	<ol style="list-style-type: none"> <li>1. Video card, if installed</li> <li>2. System board</li> </ol>
<b>005-038-XXX</b> System BIOS extension failure	<ol style="list-style-type: none"> <li>1. Video card, if installed</li> <li>2. System board</li> </ol>
<b>005-040-XXX</b> Video IRQ failure	<ol style="list-style-type: none"> <li>1. Video card, if installed</li> <li>2. System board</li> </ol>
<b>005-195-XXX</b> Video Test aborted by user	Information only Restart the test, if necessary.
<b>005-196-XXX</b> Video test halt, error threshold exceeded	<ol style="list-style-type: none"> <li>1. Press F3 to review the log file.</li> <li>2. Restart the test to reset the log file.</li> </ol>
<b>005-197-XXX</b> Video test warning	<ol style="list-style-type: none"> <li>1. Make sure the component that is called out is connected and/or enabled. See Chapter 6 “Using the Setup Utility program” on page 41.</li> <li>2. Re-run the test.</li> <li>3. Replace the component called out in warning statement.</li> <li>4. Replace the component under test.</li> </ol>
<b>005-198-XXX</b> Video test aborted	<ol style="list-style-type: none"> <li>1. If a component is called out, make sure it is connected and/or enabled. See Chapter 6 “Using the Setup Utility program” on page 41.</li> <li>2. Flash the system and re-test. See “Updating (flashing) the BIOS from a disc” on page 180.</li> <li>3. Go to “Undetermined problems” on page 66.</li> </ol>
<b>005-199-XXX</b> Video test failed, cause unknown	<ol style="list-style-type: none"> <li>1. Go to “Undetermined problems” on page 66.</li> <li>2. Flash the system and re-test. See “Updating (flashing) the BIOS from a disc” on page 180.</li> <li>3. Replace component under function test.</li> </ol>
<b>005-2XX-XXX 005-3XX-XXX</b> Video subsystem error	<ol style="list-style-type: none"> <li>1. Video card, if installed.</li> <li>2. System board</li> </ol>
<b>006-000-XXX</b> Diskette interface Test Passed	No action
<b>006-0XX-XXX</b> Diskette interface error	<ol style="list-style-type: none"> <li>1. Diskette drive Cable</li> <li>2. Diskette drive</li> <li>3. System board</li> </ol>
<b>006-195-XXX</b> Diskette interface Test aborted by user	Information only Restart the test, if necessary.

<b>Diagnostic Error Code</b>	<b>FRU/Action</b>
<b>006-196-XXX</b> Diskette interface test halt, error threshold exceeded	<ol style="list-style-type: none"> <li>1. Press F3 to review the log file.</li> <li>2. Restart the test to reset the log file.</li> </ol>
<b>006-197-XXX</b> Diskette interface test warning	<ol style="list-style-type: none"> <li>1. If a component is called out, make sure it is connected and/or enabled .</li> <li>2. Re-run the test.</li> <li>3. Replace the component that is called out in warning statement.</li> <li>4. Replace the component under test.</li> </ol>
<b>006-198-XXX</b> Diskette interface test aborted	<ol style="list-style-type: none"> <li>1. If a component is called out, make sure it is connected and/or enabled.</li> <li>2. Flash the system and re-test. See “Updating (flashing) the BIOS from a disc” on page 180.</li> <li>3. Go to “Undetermined problems” on page 66.</li> </ol>
<b>006-199-XXX</b> Diskette interface test failed, cause unknown	<ol style="list-style-type: none"> <li>1. Go to “Undetermined problems” on page 66.</li> <li>2. Flash the system and re-test.</li> <li>3. Replace component under function test.</li> </ol>
<b>006-25X-XXX</b> Diskette interface Error	<ol style="list-style-type: none"> <li>1. Diskette drive cable</li> <li>2. Diskette drive</li> <li>3. System board</li> </ol>
<b>015-000-XXX</b> USB port Interface Test Passed	No action
<b>015-001-XXX</b> USB port Presence	<ol style="list-style-type: none"> <li>1. Remove USB device(s) and re-test</li> <li>2. System board</li> </ol>
<b>015-002-XXX</b> USB port Timeout	<ol style="list-style-type: none"> <li>1. Remove USB device(s) and re-test</li> <li>2. System board</li> </ol>
<b>015-015-XXX</b> USB port External Loopback failure	<ol style="list-style-type: none"> <li>1. Remove USB device(s) and re-test</li> <li>2. System board</li> </ol>
<b>015-027-XXX</b> USB port Configuration/Setup error	<ol style="list-style-type: none"> <li>1. Flash the system. See “Updating (flashing) the BIOS from a disc” on page 180.</li> <li>2. System board</li> </ol>
<b>015-032-XXX</b> USB port Device Controller failure	System board
<b>015-034-XXX</b> USB port buffer allocation failure	<ol style="list-style-type: none"> <li>1. Reboot the system</li> <li>2. Flash the system and re-test. See “Updating (flashing) the BIOS from a disc” on page 180.</li> <li>3. Run memory test</li> <li>4. System board</li> </ol>
<b>015-035-XXX</b> USB port Reset condition detected	<ol style="list-style-type: none"> <li>1. Remove USB device(s) and re-test.</li> <li>2. System board</li> </ol>
<b>015-036-XXX</b> USB port Register error	System board
<b>015-040-XXX</b> USB port IRQ failure	<ol style="list-style-type: none"> <li>1. Run the Setup Utility program and check for conflicts.</li> <li>2. Flash the system. See “Updating (flashing) the BIOS from a disc” on page 180.</li> <li>3. System board</li> </ol>
<b>015-195-XXX</b> USB port Test aborted by user	Information only Restart the test, if necessary.

<b>Diagnostic Error Code</b>	<b>FRU/Action</b>
<b>015-196-XXX</b> USB port test halt, error threshold exceeded	<ol style="list-style-type: none"> <li>1. Press F3 to review the log file.</li> <li>2. Restart the test to reset the log file.</li> </ol>
<b>015-197-XXX</b> USB port test warning	<ol style="list-style-type: none"> <li>1. Make sure the component that is called out is connected and/or enabled. See Chapter 6 “Using the Setup Utility program” on page 41.</li> <li>2. Re-run the test.</li> <li>3. Replace the component that is called out in warning statement.</li> <li>4. Replace the component under test.</li> </ol>
<b>015-198-XXX</b> USB port test aborted	<ol style="list-style-type: none"> <li>1. If a component is called out, make sure it is connected and/or enabled. See Chapter 6 “Using the Setup Utility program” on page 41.</li> <li>2. Flash the system and re-test. See “Updating (flashing) the BIOS from a disc” on page 180.</li> <li>3. Go to “Undetermined problems” on page 66.</li> </ol>
<b>015-199-XXX</b> USB port test failed, cause unknown	<ol style="list-style-type: none"> <li>1. Go to “Undetermined problems” on page 66.</li> <li>2. Flash the system and re-test. See “Updating (flashing) the BIOS from a disc” on page 180.</li> <li>3. Replace component under function test.</li> </ol>
<b>018-000-XXX</b> PCI Card Test Passed	No action
<b>018-0XX-XXX</b> PCI Card Failure	<ol style="list-style-type: none"> <li>1. Riser card, if installed</li> <li>2. System board</li> </ol>
<b>018-195-XXX</b> PCI Card Test aborted by user	<ol style="list-style-type: none"> <li>1. PCI card</li> <li>2. Information only Restart the test, if necessary.</li> </ol>
<b>018-196-XXX</b> PCI Card test halt, error threshold exceeded	<ol style="list-style-type: none"> <li>1. Press F3 to review the log file.</li> <li>2. Restart the test to reset the log file.</li> </ol>
<b>018-197-XXX</b> PCI Card test warning	<ol style="list-style-type: none"> <li>1. Make sure the component that is called out is connected and/or enabled. See Chapter 6 “Using the Setup Utility program” on page 41.</li> <li>2. Re-run the test.</li> <li>3. Replace the component that is called out in warning statement.</li> <li>4. Replace the component under test.</li> </ol>
<b>018-198-XXX</b> PCI Card test aborted	<ol style="list-style-type: none"> <li>1. If a component is called out, make sure it is connected and/or enabled. See Chapter 6 “Using the Setup Utility program” on page 41.</li> <li>2. Flash the system and re-test. See “Updating (flashing) the BIOS from a disc” on page 180.</li> <li>3. Go to “Undetermined problems” on page 66.</li> </ol>
<b>018-199-XXX</b> PCI Card test failed, cause unknown	<ol style="list-style-type: none"> <li>1. Go to “Undetermined problems” on page 66.</li> <li>2. Flash the system and re-test. See “Updating (flashing) the BIOS from a disc” on page 180.</li> <li>3. Replace component under function test.</li> </ol>

<b>Diagnostic Error Code</b>	<b>FRU/Action</b>
<b>018-250-XXX</b> PCI Card Services error	<ol style="list-style-type: none"> <li>1. PCI card</li> <li>2. Riser card, if installed</li> <li>3. System board</li> </ol>
<b>020-000-XXX</b> PCI Interface Test Passed	No action
<b>020-0XX-XXX</b> PCI Interface error	<ol style="list-style-type: none"> <li>1. PCI card</li> <li>2. Riser card, if installed</li> <li>3. System board</li> </ol>
<b>020-195-XXX</b> PCI Test aborted by user	Information only Restart the test, if necessary.
<b>020-196-XXX</b> PCI test halt, error threshold exceeded	<ol style="list-style-type: none"> <li>1. Press F3 to review the log file.</li> <li>2. Restart the test to reset the log file.</li> </ol>
<b>020-197-XXX</b> PCI test warning	<ol style="list-style-type: none"> <li>1. Make sure the component that is called out is connected and/or enabled. See Chapter 6 “Using the Setup Utility program” on page 41.</li> <li>2. Re-run the test.</li> <li>3. Replace the component that is called out in warning statement.</li> <li>4. Replace the component under test.</li> </ol>
<b>020-198-XXX</b> PCI test aborted	<ol style="list-style-type: none"> <li>1. If a component is called out, make sure it is connected and/or enabled. See Chapter 6 “Using the Setup Utility program” on page 41.</li> <li>2. Flash the system and re-test. See “Updating (flashing) the BIOS from a disc” on page 180.</li> <li>3. Go to “Undetermined problems” on page 66.</li> </ol>
<b>020-199-XXX</b> PCI test failed, cause unknown	<ol style="list-style-type: none"> <li>1. Go to “Undetermined problems” on page 66.</li> <li>2. Flash the system and re-test. See “Updating (flashing) the BIOS from a disc” on page 180.</li> <li>3. Replace component under function test.</li> </ol>
<b>020-262-XXX</b> PCI system error	<ol style="list-style-type: none"> <li>1. PCI card</li> <li>2. Riser card, if installed</li> <li>3. System board</li> </ol>
<b>025-000-XXX</b> IDE interface Test Passed	No action
<b>025-00X-XXX 025-01X-XXX</b> IDE interface failure	<ol style="list-style-type: none"> <li>1. IDE signal cable</li> <li>2. Check power supply voltages</li> <li>3. Reseat IDE signal cable</li> <li>4. IDE device</li> <li>5. System board</li> </ol>
<b>025-027-XXX</b> IDE interface Configuration/Setup error	<ol style="list-style-type: none"> <li>1. IDE signal cable</li> <li>2. Flash the system. See “Updating (flashing) the BIOS from a disc” on page 180.</li> <li>3. Reseat IDE signal cable</li> <li>4. IDE device</li> <li>5. System board</li> </ol>

<b>Diagnostic Error Code</b>	<b>FRU/Action</b>
<b>025-02X-XXX 025-03X-XXX 025-04X-XXX</b> IDE Interface failure	<ol style="list-style-type: none"> <li>1. IDE signal cable</li> <li>2. Check AC/DC power adapter</li> <li>3. Reseat IDE signal cable</li> <li>4. IDE device</li> <li>5. System board</li> </ol>
<b>025-195-XXX</b> IDE interface Test aborted by user	Information only Restart the test, if necessary.
<b>025-196-XXX</b> IDE interface test halt, error threshold exceeded	<ol style="list-style-type: none"> <li>1. Press F3 to review the log file.</li> <li>2. Restart the test to reset the log file.</li> </ol>
<b>025-197-XXX</b> IDE interface test warning	<ol style="list-style-type: none"> <li>1. Make sure the component that is called out is connected and/or enabled. See Chapter 6 “Using the Setup Utility program” on page 41.</li> <li>2. Re-run the test.</li> <li>3. Replace the component that is called out in warning statement.</li> <li>4. Replace the component under test.</li> </ol>
<b>025-198-XXX</b> IDE interface test aborted	<ol style="list-style-type: none"> <li>1. If a component is called out, make sure it is connected and/or enabled. See Chapter 6 “Using the Setup Utility program” on page 41.</li> <li>2. Flash the system and re-test. See “Updating (flashing) the BIOS from a disc” on page 180.</li> <li>3. Go to “Undetermined problems” on page 66.</li> </ol>
<b>025-199-XXX</b> IDE interface test failed, cause unknown	<ol style="list-style-type: none"> <li>1. Go to “Undetermined problems” on page 66.</li> <li>2. Flash the system and re-test. See “Updating (flashing) the BIOS from a disc” on page 180.</li> <li>3. Replace component under function test.</li> </ol>
<b>030-000-XXX</b> SCSI interface Test Passed	No action
<b>030-00X-XXX 030-01X-XXX</b> SCSI interface failure	<ol style="list-style-type: none"> <li>1. SCSI signal cable</li> <li>2. Check AC/DC power adapter</li> <li>3. SCSI device</li> <li>4. SCSI adapter card, if installed</li> <li>5. System board</li> </ol>
<b>030-027-XXX</b> SCSI interface Configuration/Setup error	<ol style="list-style-type: none"> <li>1. SCSI signal cable</li> <li>2. Flash the system. See “Updating (flashing) the BIOS from a disc” on page 180.</li> <li>3. SCSI device</li> <li>4. SCSI adapter card, if installed</li> <li>5. System board</li> </ol>
<b>030-03X-XXX 030-04X-XXX</b> SCSI interface error	<ol style="list-style-type: none"> <li>1. SCSI signal cable</li> <li>2. Check AC/DC power adapter</li> <li>3. SCSI device</li> <li>4. SCSI adapter card, if installed</li> <li>5. System board</li> </ol>
<b>030-195-XXX</b> SCSI interface Test aborted by user	Information only Restart the test, if necessary.

<b>Diagnostic Error Code</b>	<b>FRU/Action</b>
<b>030-196-XXX</b> SCSI interface test halt, error threshold exceeded	<ol style="list-style-type: none"> <li>1. Press F3 to review the log file.</li> <li>2. Restart the test to reset the log file.</li> </ol>
<b>030-197-XXX</b> SCSI interface test warning	<ol style="list-style-type: none"> <li>1. Make sure the component that is called out is connected and/or enabled. See Chapter 6 “Using the Setup Utility program” on page 41.</li> <li>2. Re-run the test.</li> <li>3. Replace the component that is called out in warning statement.</li> <li>4. Replace the component under test.</li> </ol>
<b>030-198-XXX</b> SCSI interface test aborted	<ol style="list-style-type: none"> <li>1. If a component is called out, make sure it is connected and/or enabled. See Chapter 6 “Using the Setup Utility program” on page 41.</li> <li>2. Flash the system and re-test. See “Updating (flashing) the BIOS from a disc” on page 180.</li> <li>3. Go to “Undetermined problems” on page 66.</li> </ol>
<b>030-199-XXX</b> SCSI interface test failed, cause unknown	<ol style="list-style-type: none"> <li>1. Go to “Undetermined problems” on page 66.</li> <li>2. Flash the system and re-test. See “Updating (flashing) the BIOS from a disc” on page 180.</li> <li>3. Replace component under function test.</li> </ol>
<b>035-000-XXX</b> RAID interface Test Passed	No action
<b>035-0XX-XXX</b> RAID interface Failure	<ol style="list-style-type: none"> <li>1. RAID signal cable</li> <li>2. RAID device</li> <li>3. RAID adapter card, if installed</li> <li>4. System board</li> </ol>
<b>035-195-XXX</b> RAID interface Test aborted by user	Information only Restart the test, if necessary.
<b>035-196-XXX</b> RAID interface test halt, error threshold exceeded	<ol style="list-style-type: none"> <li>1. Press F3 to review the log file.</li> <li>2. Restart the test to reset the log file.</li> </ol>
<b>035-197-XXX</b> RAID interface test warning	<ol style="list-style-type: none"> <li>1. Make sure the component that is called out is connected and/or enabled. See Chapter 6 “Using the Setup Utility program” on page 41.</li> <li>2. Re-run the test.</li> <li>3. Replace the component that is called out in warning statement.</li> <li>4. Replace the component under test.</li> </ol>
<b>035-198-XXX</b> RAID interface test aborted	<ol style="list-style-type: none"> <li>1. If a component is called out, make sure it is connected and/or enabled. See Chapter 6 “Using the Setup Utility program” on page 41.</li> <li>2. Flash the system and re-test. See “Updating (flashing) the BIOS from a disc” on page 180.</li> <li>3. Go to “Undetermined problems” on page 66.</li> </ol>
<b>035-199-XXX</b> RAID interface test failed, cause unknown	<ol style="list-style-type: none"> <li>1. See “Undetermined problems” on page 66.</li> <li>2. Flash the system and re-test. See “Updating (flashing) the BIOS from a disc” on page 180.</li> <li>3. Replace component under function test.</li> </ol>
<b>071-000-XXX</b> Audio port Interface Test Passed	No action

<b>Diagnostic Error Code</b>	<b>FRU/Action</b>
<b>071-00X-XXX 071-01X-XXX 071-02X-XXX</b> Audio port error	<ol style="list-style-type: none"> <li>1. Run the Setup Utility program.</li> <li>2. Flash the system. See “Updating (flashing) the BIOS from a disc” on page 180.</li> <li>3. System board</li> </ol>
<b>071-03X-XXX</b> Audio port failure	<ol style="list-style-type: none"> <li>1. Speakers</li> <li>2. Microphone</li> <li>3. Audio card, if installed</li> <li>4. System board</li> </ol>
<b>071-04X-XXX</b> Audio port failure	<ol style="list-style-type: none"> <li>1. Run the Setup Utility program.</li> <li>2. Audio card, if installed</li> <li>3. System board</li> </ol>
<b>071-195-XXX</b> Audio port Test aborted by user	Information only Restart the test, if necessary.
<b>071-196-XXX</b> Audio port test halt, error threshold exceeded	<ol style="list-style-type: none"> <li>1. Press F3 to review the log file.</li> <li>2. Restart the test to reset the log file.</li> </ol>
<b>071-197-XXX</b> Audio port test warning	<ol style="list-style-type: none"> <li>1. Make sure the component that is called out is connected and/or enabled. See Chapter 6 “Using the Setup Utility program” on page 41.</li> <li>2. Re-run the test.</li> <li>3. Replace the component that is called out in warning statement.</li> <li>4. Replace the component under test.</li> </ol>
<b>071-198-XXX</b> Audio port test aborted	<ol style="list-style-type: none"> <li>1. If a component is called out, make sure it is connected and/or enabled. See Chapter 6 “Using the Setup Utility program” on page 41.</li> <li>2. Flash the system and re-test. See “Updating (flashing) the BIOS from a disc” on page 180.</li> <li>3. Go to “Undetermined problems” on page 66.</li> </ol>
<b>071-199-XXX</b> Audio port test failed, cause unknown	<ol style="list-style-type: none"> <li>1. See “Undetermined problems” on page 66.</li> <li>2. Flash the system and re-test. See “Updating (flashing) the BIOS from a disc” on page 180.</li> <li>3. Replace component under function test.</li> </ol>
<b>071-25X-XXX</b> Audio port failure	<ol style="list-style-type: none"> <li>1. Speakers</li> <li>2. Audio card, if installed</li> <li>3. System board</li> </ol>
<b>080-000-XXX</b> Game Port interface Test Passed	No action
<b>080-XXX-XXX</b> Game Port interface Error	<ol style="list-style-type: none"> <li>1. Remove the game port device and re-test the system.</li> </ol>
<b>080-195-XXX</b> Game Port interface Test aborted by user	Information only Restart the test, if necessary.
<b>080-196-XXX</b> Game Port interface test halt, error threshold exceeded	<ol style="list-style-type: none"> <li>1. Press F3 to review the log file.</li> <li>2. Restart the test to reset the log file.</li> </ol>



Diagnostic Error Code	FRU/Action
<b>080-197-XXX</b> Game Port interface test warning	<ol style="list-style-type: none"> <li>1. Make sure the component that is called out is connected and/or enabled. See Chapter 6 “Using the Setup Utility program” on page 41.</li> <li>2. Re-run the test.</li> <li>3. Replace the component that is called out in warning statement.</li> <li>4. Replace the component under test.</li> </ol>
<b>080-198-XXX</b> Game Port interface test aborted	<ol style="list-style-type: none"> <li>1. If a component is called out, make sure it is connected and/or enabled. See Chapter 6 “Using the Setup Utility program” on page 41.</li> <li>2. Flash the system and re-test. See “Updating (flashing) the BIOS from a disc” on page 180.</li> <li>3. Go to “Undetermined problems” on page 66.</li> </ol>
<b>080-199-XXX</b> Game Port interface test failed, cause unknown	<ol style="list-style-type: none"> <li>1. See “Undetermined problems” on page 66.</li> <li>2. Flash the system and re-test. See “Updating (flashing) the BIOS from a disc” on page 180.</li> <li>3. Replace component under function test.</li> </ol>
<b>086-000-XXX</b> Mouse Port interface Test Passed	No action
<b>086-001-XXX</b> Mouse Port interface Presence	<ol style="list-style-type: none"> <li>1. Mouse</li> <li>2. System board</li> </ol>
<b>086-032-XXX</b> Mouse Port interface Device controller failure	<ol style="list-style-type: none"> <li>1. Mouse</li> <li>2. System board</li> </ol>
<b>086-035-XXX</b> Mouse Port interface Reset	<ol style="list-style-type: none"> <li>1. Mouse</li> <li>2. System board</li> </ol>
<b>086-040-XXX</b> Mouse Port interface IRQ failure	<ol style="list-style-type: none"> <li>1. Run the Setup Utility program.</li> <li>2. Mouse</li> <li>3. System board</li> </ol>
<b>086-195-XXX</b> Mouse Port interface Test aborted by user	Information only Restart the test, if necessary.
<b>086-196-XXX</b> Mouse Port interface test halt, error threshold exceeded	<ol style="list-style-type: none"> <li>1. Press F3 to review the log file.</li> <li>2. Restart the test to reset the log file.</li> </ol>
<b>086-197-XXX</b> Mouse Port interface test warning	<ol style="list-style-type: none"> <li>1. Make sure the component that is called out is connected and/or enabled. See Chapter 6 “Using the Setup Utility program” on page 41.</li> <li>2. Re-run the test.</li> <li>3. Replace the component that is called out in warning statement.</li> <li>4. Replace the component under test.</li> </ol>
<b>086-198-XXX</b> Mouse Port interface test aborted	<ol style="list-style-type: none"> <li>1. If a component is called out, make sure it is connected and/or enabled. See Chapter 6 “Using the Setup Utility program” on page 41.</li> <li>2. Flash the system and re-test. See “Updating (flashing) the BIOS from a disc” on page 180.</li> <li>3. Go to “Undetermined problems” on page 66.</li> </ol>

<b>Diagnostic Error Code</b>	<b>FRU/Action</b>
<b>086-199-XXX</b> Mouse Port interface test failed, cause unknown	<ol style="list-style-type: none"> <li>1. See “Undetermined problems” on page 66.</li> <li>2. Flash the system and re-test. See “Updating (flashing) the BIOS from a disc” on page 180.</li> <li>3. Replace component under function test.</li> </ol>
<b>089-000-XXX</b> Microprocessor Test Passed	No action
<b>089-XXX-XXX</b> Microprocessor failure	<ol style="list-style-type: none"> <li>1. Microprocessor(s)</li> <li>2. System board</li> </ol>
<b>089-195-XXX</b> Microprocessor Test aborted by user	Information only Restart the test, if necessary.
<b>089-196-XXX</b> Microprocessor test halt, error threshold exceeded	<ol style="list-style-type: none"> <li>1. Press F3 to review the log file.</li> <li>2. Restart the test to reset the log file.</li> </ol>
<b>089-197-XXX</b> Microprocessor test warning	<ol style="list-style-type: none"> <li>1. Make sure the component that is called out is connected and/or enabled. See Chapter 6 “Using the Setup Utility program” on page 41.</li> <li>2. Re-run the test.</li> <li>3. Replace the component that is called out in warning statement.</li> <li>4. Replace the component under test.</li> </ol>
<b>089-198-XXX</b> Microprocessor test aborted	<ol style="list-style-type: none"> <li>1. Flash the system. See “Updating (flashing) the BIOS from a disc” on page 180.</li> <li>2. Go to “Undetermined problems” on page 66.</li> </ol>
<b>089-199-XXX</b> Microprocessor test failed, cause unknown	<ol style="list-style-type: none"> <li>1. See “Undetermined problems” on page 66.</li> <li>2. Flash the system and re-test. See “Updating (flashing) the BIOS from a disc” on page 180.</li> <li>3. Replace component under function test.</li> </ol>
<b>170-000-XXX</b> Voltage Sensor(s) Test Passed	No action
<b>170-0XX-XXX</b> Voltage Sensor(s) failure	<ol style="list-style-type: none"> <li>1. Flash system</li> <li>2. System board</li> </ol>
<b>170-195-XXX</b> Voltage Sensor(s) Test aborted by user	Information only Restart the test, if necessary.
<b>170-196-XXX</b> Voltage Sensor(s) test halt, error threshold exceeded	<ol style="list-style-type: none"> <li>1. Press F3 to review the log file.</li> <li>2. Restart the test to reset the log file.</li> </ol>
<b>170-197-XXX</b> Voltage Sensor(s) test warning	<ol style="list-style-type: none"> <li>1. Make sure the component that is called out is connected and/or enabled. See Chapter 6 “Using the Setup Utility program” on page 41.</li> <li>2. Re-run the test.</li> <li>3. Replace the component that is called out in warning statement.</li> <li>4. Replace the component under test.</li> </ol>
<b>170-198-XXX</b> Voltage Sensor(s) test aborted	<ol style="list-style-type: none"> <li>1. If a component is called out, make sure it is connected and/or enabled. See Chapter 6 “Using the Setup Utility program” on page 41.</li> <li>2. Flash the system and re-test. See “Updating (flashing) the BIOS from a disc” on page 180.</li> <li>3. Go to “Undetermined problems” on page 66.</li> </ol>

<b>Diagnostic Error Code</b>	<b>FRU/Action</b>
<b>170-199-XXX</b> Voltage Sensor(s) test failed, cause unknown	<ol style="list-style-type: none"> <li>1. See “Undetermined problems” on page 66.</li> <li>2. Flash the system and re-test. See “Updating (flashing) the BIOS from a disc” on page 180.</li> <li>3. Replace component under function test.</li> </ol>
<b>170-250-XXX 170-251-XXX</b> Voltage Sensor(s) Voltage limit error	<ol style="list-style-type: none"> <li>1. AC/DC power adapter</li> <li>2. System board</li> </ol>
<b>170-254-XXX</b> Voltage Sensor(s) Voltage Regulator Module error	<ol style="list-style-type: none"> <li>1. Voltage Regulator Module (VRM)</li> <li>2. Microprocessor</li> <li>3. System board</li> </ol>
<b>175-000-XXX</b> Thermal Sensor(s) Test Passed	No action
<b>175-0XX-XXX</b> Thermal Sensor(s) failure	<ol style="list-style-type: none"> <li>1. Flash system</li> <li>2. System board</li> </ol>
<b>175-195-XXX</b> Thermal Sensor(s) Test aborted by user	Information only Restart the test, if necessary
<b>175-196-XXX</b> Thermal Sensor(s) test halt, error threshold exceeded	<ol style="list-style-type: none"> <li>1. Press F3 to review the log file.</li> <li>2. Restart the test to reset the log file.</li> </ol>
<b>175-197-XXX</b> Thermal Sensor(s) test warning	<ol style="list-style-type: none"> <li>1. Make sure the component that is called out is connected and/or enabled. See Chapter 6 “Using the Setup Utility program” on page 41.</li> <li>2. Re-run test.</li> <li>3. Replace the component that is called out in warning statement.</li> <li>4. Replace the component under test.</li> </ol>
<b>175-198-XXX</b> Thermal Sensor(s) test aborted	<ol style="list-style-type: none"> <li>1. If a component is called out, make sure it is connected and/or enabled .</li> <li>2. Flash the system and re-test. See “Updating (flashing) the BIOS from a disc” on page 180.</li> <li>3. Go to “Undetermined problems” on page 66.</li> </ol>
<b>175-199-XXX</b> Thermal Sensor(s) test failed, cause unknown	<ol style="list-style-type: none"> <li>1. See “Undetermined problems” on page 66.</li> <li>2. Flash the system and re-test. See “Updating (flashing) the BIOS from a disc” on page 180.</li> <li>3. Replace component under function test.</li> </ol>
<b>175-250-XXX 175-251-XXX</b> Thermal Sensor(s) limit error	<ol style="list-style-type: none"> <li>1. Check fans</li> <li>2. Check AC/DC power adapter voltages.</li> <li>3. Microprocessor</li> <li>4. System board</li> </ol>
<b>185-000-XXX</b> Asset Security Test Passed	No action
<b>185-XXX-XXX</b> Asset Security failure	<ol style="list-style-type: none"> <li>1. Flash system</li> <li>2. System board</li> </ol>
<b>185-278-XXX</b> Asset Security Chassis Intrusion	<ol style="list-style-type: none"> <li>1. Assure Asset Security Enabled</li> <li>2. C2 Cover Switch</li> <li>3. System board</li> </ol>
<b>201-000-XXX</b> System Memory Test Passed	No action

<b>Diagnostic Error Code</b>	<b>FRU/Action</b>
<b>201-XXX-XXX</b> System Memory error	<ol style="list-style-type: none"> <li>1. Replace the memory module called out by the test</li> <li>2. System board</li> </ol>
<b>202-000-XXX</b> System Cache Test Passed	No action
<b>202-XXX-XXX</b> System Cache error	<ol style="list-style-type: none"> <li>1. Cache, if removable</li> <li>2. System board</li> <li>3. Microprocessor</li> </ol>
<b>206-000-XXX</b> Diskette Drive Test Passed	No action
<b>206-XXX-XXX</b> Diskette Drive error	<ol style="list-style-type: none"> <li>1. Diskette Drive Cable</li> <li>2. Check AC/DC power adapter voltages</li> <li>3. Diskette drive</li> <li>4. System board</li> </ol>
<b>215-000-XXX</b> CD-ROM Drive Test Passed	No action
<b>215-XXX-XXX</b> CD-ROM Drive error	<ol style="list-style-type: none"> <li>1. CD-ROM Drive Cable</li> <li>2. Check AC/DC power adapter voltages</li> <li>3. CD-ROM drive</li> <li>4. System board</li> </ol>
<b>217-000-XXX</b> Hard Disk Drive Test Passed	No action
<b>217-25X-XXX 217-26X-XXX</b> Hard Disk Drive (IDE) error	<ol style="list-style-type: none"> <li>1. Hard Disk Drive Cable</li> <li>2. Check AC/DC power adapter voltages</li> <li>3. Reseat the hard disk drive cable</li> <li>4. Hard Disk drive (IDE)</li> <li>5. System board</li> </ol>
<b>217-28X-XXX 217-29X-XXX</b> Hard Disk Drive (SCSI) error	<ol style="list-style-type: none"> <li>1. Hard Disk Drive Cable</li> <li>2. Check AC/DC power adapter voltages</li> <li>3. Reseat the hard disk drive cable</li> <li>4. Hard Disk drive (SCSI)</li> <li>5. SCSI adapter card</li> <li>6. System board</li> </ol>
<b>220-000-XXX</b> Hi-Capacity Cartridge Drive Test Passed	No action
<b>220-XXX-XXX</b> Hi-Capacity Cartridge Drive error	<ol style="list-style-type: none"> <li>1. Remove the Hi-Capacity Cartridge Drive and re-test the system.</li> </ol>
<b>301-XXX-XXX</b> Keyboard error	<ol style="list-style-type: none"> <li>1. Keyboard</li> <li>2. Check and test mouse</li> <li>3. System board</li> </ol>
<b>301-000-XXX</b> Keyboard Test Passed	No action
<b>302-000-XXX</b> Mouse Test Passed	No action
<b>302-XXX-XXX</b> Mouse error	<ol style="list-style-type: none"> <li>1. Mouse</li> <li>2. Check and test Keyboard</li> <li>3. System board</li> </ol>
<b>303-000-XXX</b> Joystick Test Passed	No action
<b>303-XXX-XXX</b> Joystick error	Remove the Joystick and re-test the system

Diagnostic Error Code	FRU/Action
305-000-XXX Monitor DDC Test Passed	No action
305-250-XXX Monitor DDC self test failure	<ol style="list-style-type: none"> <li>1. Run the Setup Utility program to enable DDC</li> <li>2. Cable</li> <li>3. Monitor</li> <li>4. Video card</li> <li>5. System board</li> </ol>
415-000-XXX Modem Test Passed	No action
415-XXX-XXX Modem error	Remove the Modem and re-test the system

## Beep symptoms

Beep symptoms are tones or a series of tones separated by pauses (intervals without sound) during POST.

The following tables describes beep symptoms.

Beep Symptom	FRU/Action
2 short 1 long beeps	Reseat the memory modules. If the error persists, replace the memory modules one at a time until the failing module is determined.
4, 5, 6, or 7 beeps 9, 10, or 11 beeps	Before replacing the system board, remove any optional adapters (Express card, Modem card, Media reader) and retry. If the problem persists, replace the system board. Otherwise, reinstall the optional adapters one at a time until the failing adapter is determined.
8 beeps	Replace the system board.

## POST error codes

Each time you turn on your computer, it performs a series of tests to check the operation of the computer components and some optional devices in the computer. This series of tests is called the *power-on self-test*, or POST. The POST does the following operations:

- Checks some basic system board operations
- Checks the memory operation
- Starts the video operation
- Verifies that the boot drive is working

If the POST detects a problem, an error message is displayed on the screen. A single problem can cause several error messages. When you correct the cause of the first error message, the other error messages probably will not be displayed the next time you turn on the computer.

Error code	POST error message	Description/Action
	CMOS Battery Failure	The CMOS battery is no longer functional.  Replace the battery.
	Keyboard error or no keyboard present	Cannot initialize the keyboard.  Make sure the keyboard is correctly connected to the computer and that no keys are held pressed during the POST.  To purposely configure the computer without a keyboard, set the error halt condition in the Setup Utility program to HALT ON ALL, BUT KEYBOARD. The BIOS then ignores the missing keyboard during the POST.
	Press TAB to show POST screen	Pressing the TAB key permits you to toggle between the default POST screen and a custom POST display screen.
	Main processor	The main microprocessor information is displayed on the POST screen.
	Installed memory:	The total size of installed memory modules is displayed on the POST screen.
	SATA 0:	The hard disk drive information is displayed on the POST screen.
0210	Stuck key	When a key is kept pressed for a long time, the error message will be displayed during the POST.
0135	Fan failure	The system might be overheating.  Press F10 to exit.  <b>Note:</b> If the problem is caused by the microprocessor fan, pressing F10 will not solve the problem.
0211	Keyboard not found	When there is no keyboard detected, the error message will be displayed.
0164	Memory size decreased	Press F10 to exit.
1762	Configuration change has occurred	This error message is displayed when a hard disk drive or optical drive change has been made.  Press F10 to exit.
0662	Configuration change has occurred	This error message is displayed when a floppy drive change has been made.  Press F10 to exit.

Error code	POST error message	Description/Action
1820	More than one external fingerprint reader is attached. Power off and remove all but the reader that you set up within your main operating system.	If more than one external fingerprint reader is connected to a computer, this error message will be displayed to inform you to remove all of the fingerprint keyboards except the one compatible with the fingerprint application on your computer.
1962	No operating system found. Press any key to repeat boot sequence.	This error occurs only after the POST is completed.  Press any key to repeat boot sequence.

## Miscellaneous error messages

Message/Symptom	FRU/Action
Changing display colors	Display/Monitor
Computer will <i>not</i> power-off. See "Power problems" on page 33.	<ol style="list-style-type: none"> <li>1. Power Switch</li> <li>2. System Board</li> <li>3. Riser card, if installed</li> </ol>
Computer will <i>not</i> PXE from server	<ol style="list-style-type: none"> <li>1. Ensure that network is in startup sequence as first device or first device after diskette</li> <li>2. Ensure that network adapter is enabled for PXE</li> <li>3. Network adapter (Advise network administrator of new MAC address)</li> </ol>
Computer will <i>not</i> perform a Wake on LAN® (if applicable)	<ol style="list-style-type: none"> <li>1. Check power supply and signal cable connections to network adapter.</li> <li>2. Ensure that the operating system settings are set to enable Wake on LAN.</li> <li>3. Ensure Wake on LAN feature is enabled in Setup/Configuration (see "Starting the Setup Utility program" on page 41)</li> <li>4. Ensure network administrator is using correct MAC address.</li> <li>5. Ensure no interrupt or I/O address conflicts.</li> <li>6. Network adapter (advise network administrator of new MAC address)</li> </ol>
Dead computer. See "Power problems" on page 33.	<ol style="list-style-type: none"> <li>1. AC/DC Power Adapter</li> <li>2. System Board</li> </ol>
Diskette drive in-use light remains on or does not light when drive is active.	<ol style="list-style-type: none"> <li>1. Diskette Drive</li> <li>2. System Board</li> <li>3. Diskette Drive Cable</li> </ol>
Flashing cursor with an otherwise blank display.	<ol style="list-style-type: none"> <li>1. System Board</li> <li>2. Primary Hard Disk Drive</li> <li>3. Hard Disk Drive Cable</li> </ol>

Message/Symptom	FRU/Action
Incorrect memory size during POST	<ol style="list-style-type: none"> <li>1. Run the Memory tests</li> <li>2. Memory Module</li> <li>3. System Board</li> </ol>
"Insert a Diskette" icon appears with a known-good diagnostics diskette in the first 3.5-inch diskette drive.	<ol style="list-style-type: none"> <li>1. System Board</li> <li>2. Diskette Drive Cable</li> <li>3. Network Adapter</li> </ol>
Intensity or color varies from left to right of characters and color bars	<ol style="list-style-type: none"> <li>1. Display</li> <li>2. Video adapter (if present)</li> <li>3. System Board</li> </ol>
No power or fan not running	See "Power problems" on page 33.
Non-system disk or disk error-type message with a known-good diagnostic diskette.	<ol style="list-style-type: none"> <li>1. Diskette Drive</li> <li>2. System Board</li> <li>3. Diskette Drive Cable</li> </ol>
Other display symptoms not listed above (including blank or illegible display)	<ol style="list-style-type: none"> <li>1. Display</li> <li>2. System Board</li> </ol>
Power-on indicator or hard disk drive in-use light not on, but computer works correctly	<ol style="list-style-type: none"> <li>1. Power switch/LED assembly</li> <li>2. System Board</li> </ol>
Printer problems	<ol style="list-style-type: none"> <li>1. Printer</li> <li>2. System Board</li> </ol>
Program loads from the hard disk with a known-good diagnostics diskette in the first 3.5-inch diskette drive	<ol style="list-style-type: none"> <li>1. Run the Setup and Utility program and check Startup sequence.</li> <li>2. Diskette Drive</li> <li>3. Diskette Drive Cable</li> <li>4. System Board</li> <li>5. AC/DC power adapter</li> </ol>
PXE computer cannot access programs from its own hard disk.	Replace the hard disk drive
PXE computer does not PXE from server	<ol style="list-style-type: none"> <li>1. Check startup sequence</li> <li>2. Check the network adapter LED status</li> </ol>
Some or all keys on the keyboard do not work	<ol style="list-style-type: none"> <li>1. Keyboard</li> <li>2. Keyboard Cable</li> <li>3. System Board</li> </ol>

## Undetermined problems

If you encounter undetermined problems, do the following:

1. Turn off the computer and the power.
2. Remove or disconnect the following components (if installed) one at a time.
  - a. External devices (modem, printer, or mouse)
  - b. Any adapter cards
  - c. Memory modules
  - d. Extended video memory



- e. External Cache
  - f. External Cache RAM
  - g. Hard disk drive
  - h. Diskette drive
3. Turn on the power and the computer to re-test the system.
  4. Repeat steps 1 through 3 until you find the failing device or adapter cards.

If all devices and adapter cards have been removed, and the problem continues, replace the system board. See “Replacing the system board” on page 86.



---

## Chapter 8. Replacing FRUs

This chapter provides step-by-step instructions for replacing major FRUs.

### Important

Be sure to read and understand the Chapter 2 “Safety information” on page 3 before replacing any FRU. These precautions and guidelines will help you work safely.

FRU replacements are to be done only by trained service technicians.

---

## Locations

This section provides information to help you locate the connectors on the front and rear of your computer, parts on the system board, and components and internal drives in your computer.

### Locating connectors, controls, and indicators on the front of your computer

Figure 1 “Front connector, control, and indicator locations” on page 69 shows the locations of the connectors, controls, and indicators on the front of your computer.

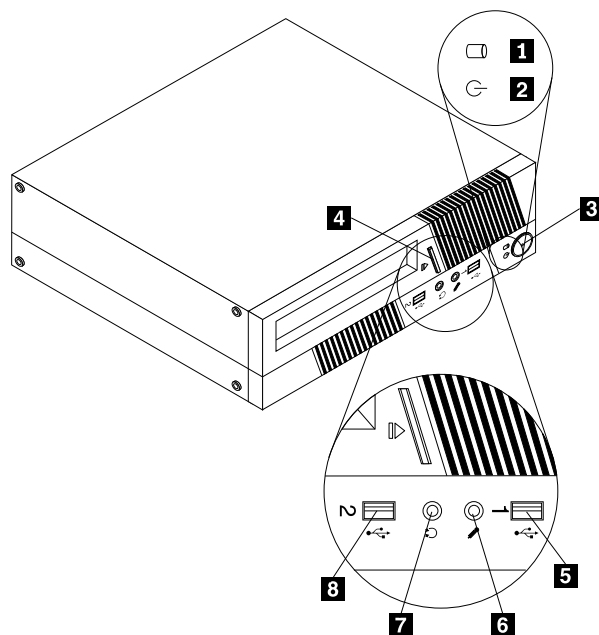

Figure 1. Front connector, control, and indicator locations

- |   |                                     |
|---|-------------------------------------|
| <b>1</b> Hard disk drive activity indicator | <b>5</b> USB connector (USB port 1) |
| <b>2</b> Power indicator                    | <b>6</b> Microphone connector       |
| <b>3</b> Power switch                       | <b>7</b> Headphone connector        |
| <b>4</b> Optical drive eject/close button   | <b>8</b> USB connector (USB port 2) |

## Locating connectors on the rear of your computer

Figure 2 “Rear connector locations” on page 70 shows the locations of the connectors on the rear of your computer. Some connectors on the rear of your computer are color-coded to help you determine where to connect the cables on your computer.

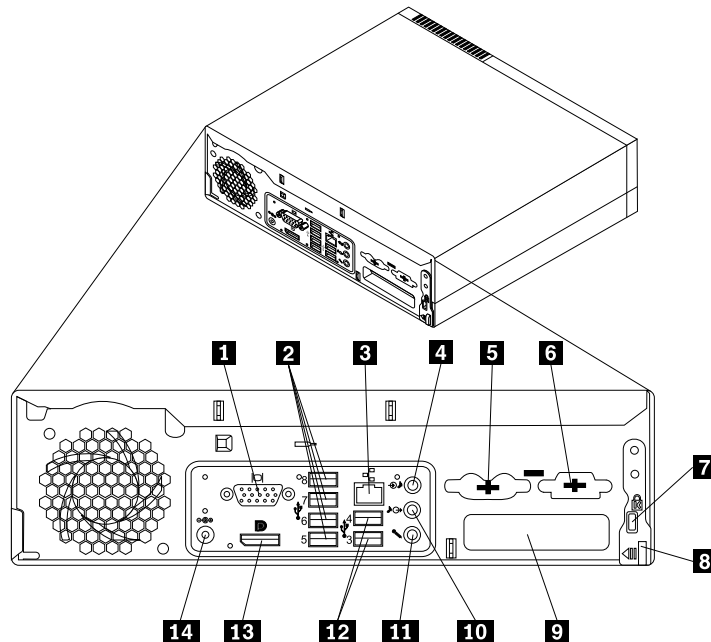

Figure 2. Rear connector locations

- |  |  |
|--|--|
| <b>1</b> VGA monitor connector                         | <b>8</b> Cover-release button                |
| <b>2</b> USB connectors (USB ports 5 to 8)             | <b>9</b> PCI card slot                       |
| <b>3</b> Ethernet connector                            | <b>10</b> Audio line-out connector           |
| <b>4</b> Audio line-in connector                       | <b>11</b> Microphone connector               |
| <b>5</b> PS/2 keyboard and mouse connectors (optional) | <b>12</b> USB connectors (USB ports 3 and 4) |
| <b>6</b> Serial port (optional)                        | <b>13</b> DisplayPort connector              |
| <b>7</b> Integrated cable lock slot                    | <b>14</b> ac power adapter connector         |

## Locating components

Figure 3 “Component locations” on page 71 shows the locations of the various components in your computer. To open the computer cover, see “Opening the computer cover” on page 72.

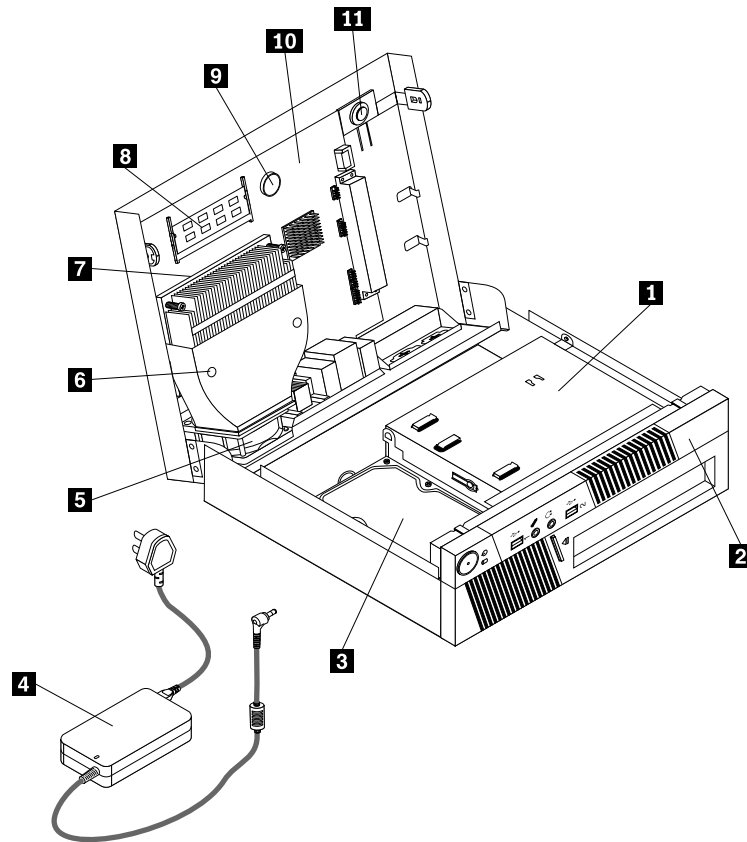

Figure 3. Component locations

- |                              |                            |
|------------------------------|----------------------------|
| <b>1</b> Optical drive       | <b>7</b> Microprocessor    |
| <b>2</b> Front bezel         | <b>8</b> Memory module     |
| <b>3</b> Hard disk drive     | <b>9</b> Battery           |
| <b>4</b> Power adapter       | <b>10</b> System board     |
| <b>5</b> System fan assembly | <b>11</b> Internal speaker |
| <b>6</b> Heat sink           |                            |

## Locating parts on the system board

Figure 4 “System board part locations” on page 72 shows the locations of the parts on the system board.

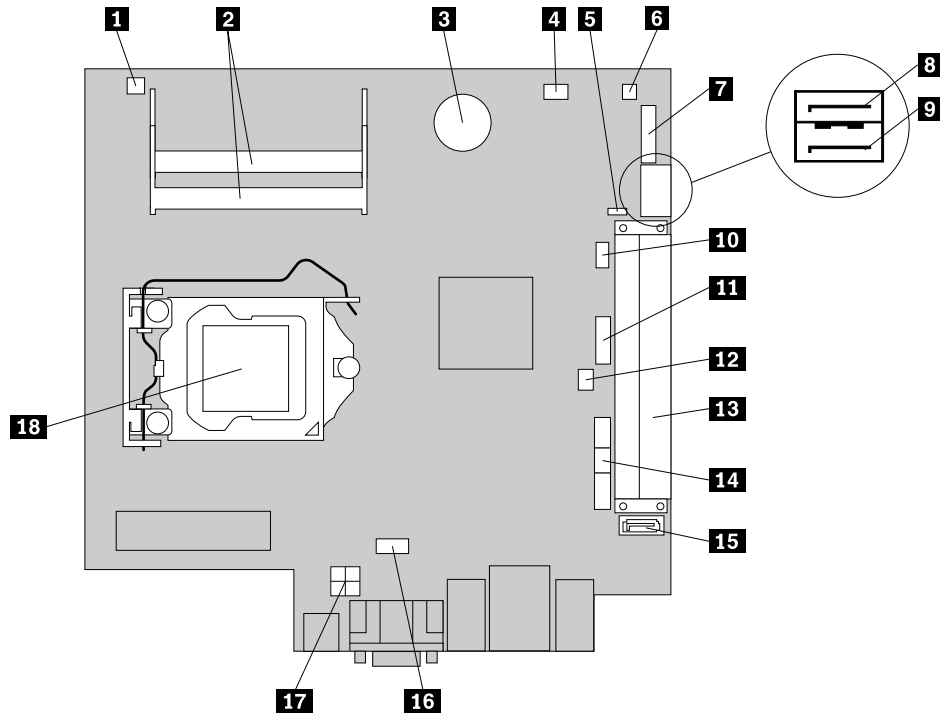

Figure 4. System board part locations

- |  |  |
|--|--|
| <b>1</b> Thermal sensor connector  | <b>10</b> PS/2 keyboard and mouse connector  |
| <b>2</b> Memory slots (2)  | <b>11</b> Front USB connector 2 (for connecting additional USB devices)  |
| <b>3</b> Battery   | <b>12</b> Cover presence switch connector (Intrusion switch connector)   |
| <b>4</b> Microprocessor fan connector  | <b>13</b> PCI card slot  |
| <b>5</b> Clear CMOS (Complementary Metal Oxide Semiconductor) /Recovery jumper | <b>14</b> Front USB, front panel, and front audio connector (for connecting USB ports 1 and 2 on the front bezel, LED indicators and power switch, and microphone and headphone connectors on the front bezel) |
| <b>6</b> Internal speaker connector  | <b>15</b> SATA connector 1 (SATA 3.0 connector)  |
| <b>7</b> Serial (COM2) connector   | <b>16</b> System fan connector   |
| <b>8</b> eSATA connector   | <b>17</b> 4-pin power connector  |
| <b>9</b> SATA connector 2 (SATA 2.0 connector)                                 | <b>18</b> Microprocessor   |

## Opening the computer cover

### Attention:

Do not open your computer or attempt any repair before reading and understanding the “Important safety information” in the *ThinkCentre User Guide*. To obtain a copy of the *ThinkCentre User Guide*, go to: <http://www.lenovo.com/ThinkCentreUserGuides>

This section provides instructions on how to open the computer cover.

**CAUTION:**



**Turn off the computer and wait three to five minutes to let the computer cool before opening the computer cover.**

To open the computer cover, do the following:

1. Remove all media from the drives. Then, turn off all attached devices and the computer.
2. Disconnect all power cords from electrical outlets.
3. Disconnect the power cords, Input/Output cables, and any other cables that are connected to the computer. See “Locating connectors, controls, and indicators on the front of your computer” on page 69 and “Locating connectors on the rear of your computer” on page 70.
4. Remove any locking device that secures the computer cover, such as an integrated cable lock.
5. Carefully lift and position the computer upside down as shown.
6. Pivot the cover-release button **1** on the rear of the computer and then open the computer cover as shown.

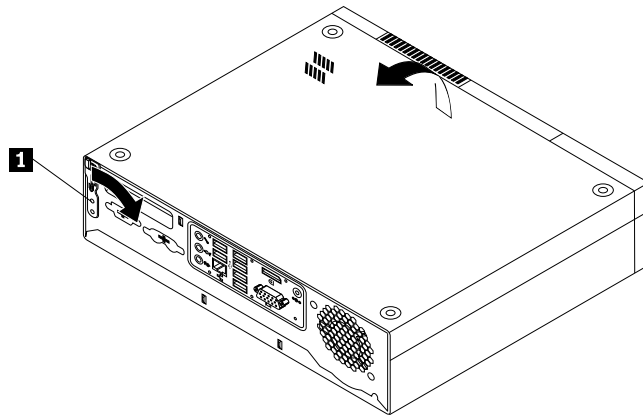

Figure 5. Opening the computer cover

---

## Removing and reinstalling the front bezel

**Attention:**

Do not open your computer or attempt any repair before reading and understanding the “Important safety information” in the *ThinkCentre User Guide*. To obtain a copy of the *ThinkCentre User Guide*, go to:  
<http://www.lenovo.com/ThinkCentreUserGuides>

This section provides instructions on how to remove and reinstall the front bezel.

To remove and reinstall the front bezel, do the following:

1. Remove all media from the drives and turn off all attached devices and the computer. Then, disconnect all power cords from electrical outlets and disconnect all cables that are connected to the computer.
2. Open the computer cover. See “Opening the computer cover” on page 72.

3. Remove the front bezel by releasing the two plastic tabs and pivoting the front bezel outward.

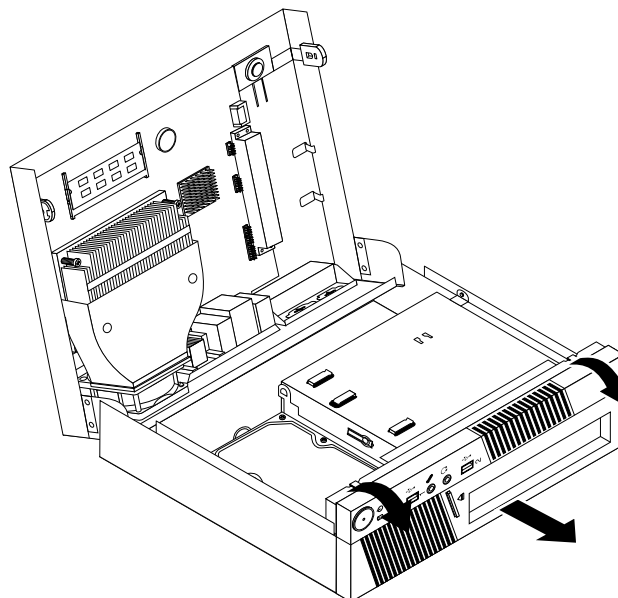

Figure 6. Removing the front bezel

4. To reinstall the front bezel, align the plastic tabs on the bottom of the bezel with the corresponding holes in the chassis, and then pivot the front bezel inward until it snaps into position.
5. Go to “Completing the parts replacement” on page 98.

---

## Installing or replacing a memory module

**Attention:**

Do not open your computer or attempt any repair before reading and understanding the “Important safety information” in the *ThinkCentre User Guide*. To obtain a copy of the *ThinkCentre User Guide*, go to: <http://www.lenovo.com/ThinkCentreUserGuides>

This section provides instructions on how to install or replace a memory module.

Your computer has four slots for installing or replacing DDR3 UDIMMs that provide up to a maximum of 16 GB system memory. When installing or replacing a memory module, Use 1 GB, 2 GB, 4 GB, or 8 GB DDR3 UDIMMs in any combination up to a maximum of 16 GB.

To install or replace a memory module, do the following:

1. Remove all media from the drives and turn off all attached devices and the computer. Then, disconnect all power cords from electrical outlets and disconnect all cables that are connected to the computer.
2. Open the computer cover. See “Opening the computer cover” on page 72.
3. Locate the memory slots. See “Locating parts on the system board” on page 71.



4. Open the retaining clips. If you are replacing an old memory module, open the retaining clips and remove the memory module being replaced as shown.

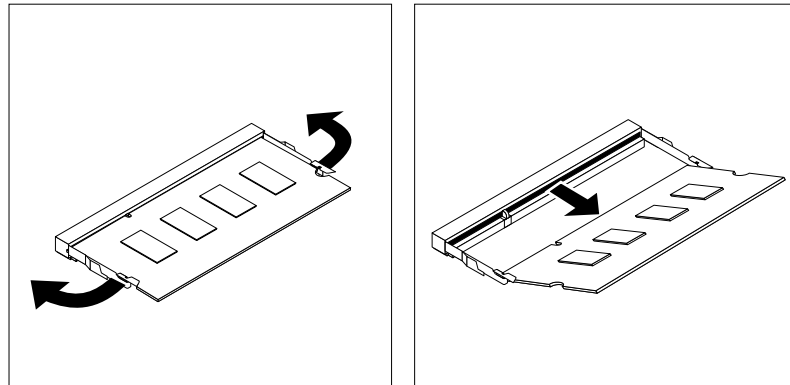

Figure 7. Removing the memory module

5. Insert the notched end **2** of the new memory module into the slot **1**. Press the memory module firmly and pivot the memory module until it snaps into place. Make sure that the memory module is secured in the slot and does not move easily.

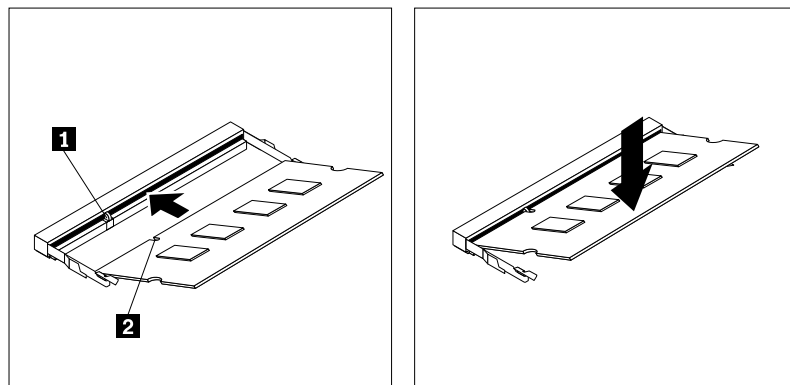

Figure 8. Installing a memory module

6. Go to “Completing the parts replacement” on page 98.

---

## Installing or replacing the PCI card

**Attention:**

Do not open your computer or attempt any repair before reading and understanding the “Important safety information” in the *ThinkCentre User Guide*. To obtain a copy of the *ThinkCentre User Guide*, go to: <http://www.lenovo.com/ThinkCentreUserGuides>

This section provides instructions on how to replace a PCI card.

To install or replace a PCI card, do the following:

1. Remove all media from the drives and turn off all attached devices and the computer. Then, disconnect all power cords from electrical outlets and disconnect all cables that are connected to the computer.

2. Open the computer cover. See “Opening the computer cover” on page 72.
3. Locate the system board and disconnect all cables connected to the system board. See “Locating parts on the system board” on page 71.
4. Press inward on the two side tabs and then pivot the system board to release it from the chassis.

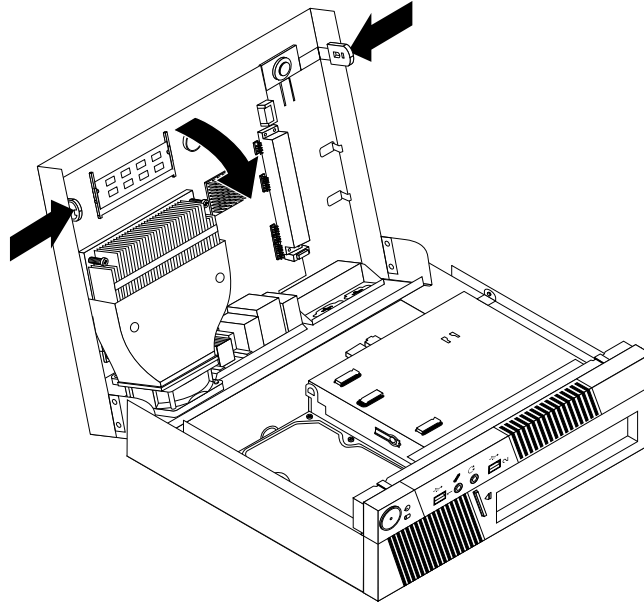

Figure 9. Releasing the system board

5. Place the system board on a clean and flat surface.
6. Locate the PCI card slot. See “Locating parts on the system board” on page 71.
7. Rotate the PCI card retainer to the open position.
8. Depending on whether you are installing or replacing a PCI card, do one of the following:
  - If you are installing a PCI card, remove the metal slot cover.
  - If you are replacing an old PCI card, grasp the old card that is currently installed and gently pull it out of the slot.

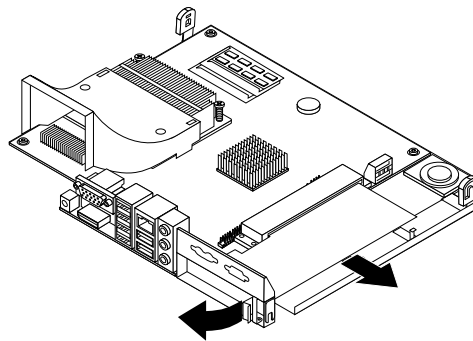

Figure 10. Removing the PCI card

9. Remove the new PCI card from its static-protective package.

10. Install the new PCI card into the PCI card slot. Make sure that the PCI card is firmly fixed in the slot and does not move easily.
11. Close the PCI card retainer.
12. Slide the system board to the rear of the chassis and then pivot the system board until it snaps into position.
13. Reconnect all cables that were disconnected from the system board.
14. Go to “Completing the parts replacement” on page 98.

---

## Replacing the hard disk drive

**Attention:**

Do not open your computer or attempt any repair before reading and understanding the “Important safety information” in the *ThinkCentre User Guide*. To obtain a copy of the *ThinkCentre User Guide*, go to:  
<http://www.lenovo.com/ThinkCentreUserGuides>

This section provides instructions on how to replace the hard disk drive.

To replace the hard disk drive, do the following:

1. Remove all media from the drives and turn off all attached devices and the computer. Then, disconnect all power cords from electrical outlets and disconnect all cables that are connected to the computer.
2. Open the computer cover. See “Opening the computer cover” on page 72.
3. Disconnect the power cable from the optical drive first.
4. Press inward on the side tabs of the hard disk drive bracket. Place your finger on the tab located on the front of the hard disk drive bracket and then pivot the hard disk drive upward to remove it from the hard disk drive bay.

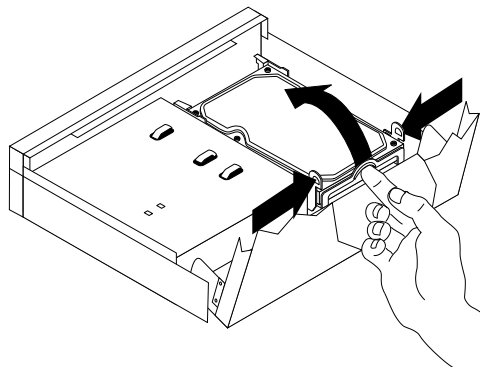

Figure 11. Removing the hard disk drive

5. Disconnect the signal cable and the power cable from the rear of the hard disk drive.
6. Flex the sides of the hard disk drive bracket properly to remove the hard disk drive out of the bracket.

7. To install the new hard disk drive into the bracket, flex the bracket and align pin **1**, pin **2**, pin **3**, and pin **4** on the bracket with the corresponding holes in the hard disk drive. Do not touch the circuit board **5** on the bottom of the hard disk drive.

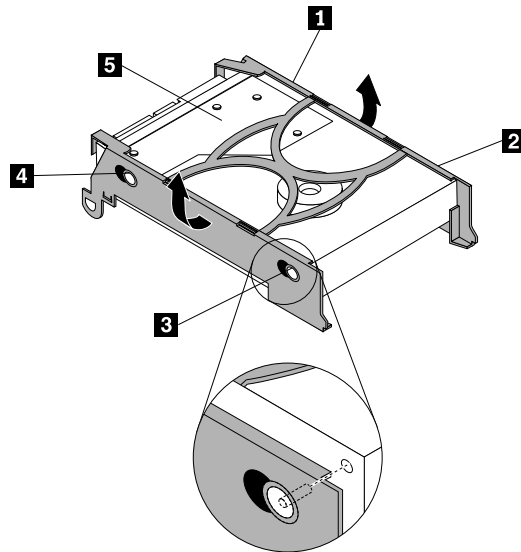

Figure 12. Installing the hard disk drive into the bracket

8. Connect the signal cable and the power cable to the rear of the new hard disk drive.
9. Slide the new hard disk drive into the hard disk drive bay and pivot it down until it snaps into position.
10. Reconnect the power cable to the optical drive.
11. Go to “Completing the parts replacement” on page 98.

---

## Replacing the optical drive

**Attention:**

Do not open your computer or attempt any repair before reading and understanding the “Important safety information” in the *ThinkCentre User Guide*. To obtain a copy of the *ThinkCentre User Guide*, go to:  
<http://www.lenovo.com/ThinkCentreUserGuides>

This section provides instructions on how to replace the optical drive.

To replace the optical drive, do the following:

1. Remove all media from the drives and turn off all attached devices and the computer. Then, disconnect all power cords from electrical outlets and disconnect all cables that are connected to the computer.
2. Open the computer cover. See “Opening the computer cover” on page 72.
3. Remove the front bezel. See “Removing and reinstalling the front bezel” on page 73.
4. Disconnect the signal cable and the power cable from the rear of the optical drive.

5. Press the blue release button and slide the optical drive out the front of the computer.

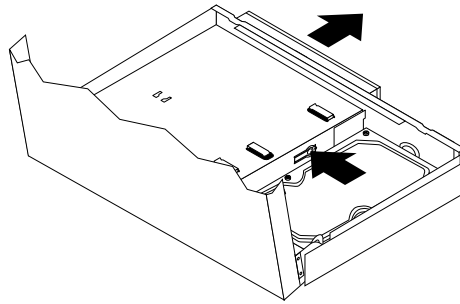

Figure 13. Removing the optical drive

6. Install the optical drive retainer **1** on the side of the new optical drive.

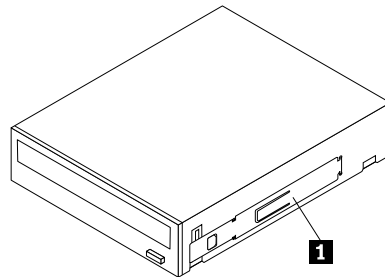

Figure 14. Installing the retainer on the optical drive

7. Slide the new optical drive into the drive bay until it snaps into position.

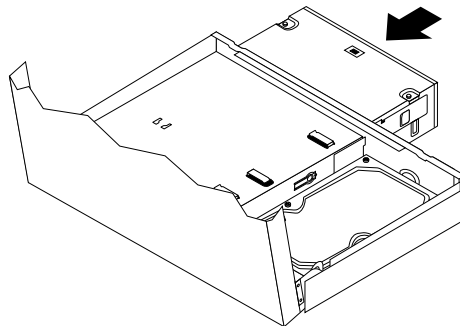

Figure 15. Installing the optical drive

8. Connect the signal cable and the power cable to the new optical drive.
9. Reinstall the front bezel. See “Removing and reinstalling the front bezel” on page 73.
10. Go to “Completing the parts replacement” on page 98.

## Replacing the battery

**Attention:**

Do not open your computer or attempt any repair before reading and understanding the “Important safety information” in the *ThinkCentre User Guide*. To obtain a copy of the *ThinkCentre User Guide*, go to:  
<http://www.lenovo.com/ThinkCentreUserGuides>

Your computer has a special type of memory that maintains the date, time, and settings for built-in features, such as parallel-port assignments (configuration). A battery keeps this information active when you turn off the computer.

The battery normally requires no charging or maintenance throughout its life; however, no battery lasts forever. If the battery fails, the date, time, and configuration information (including passwords) are lost. An error message is displayed when you turn on the computer.

Refer to the “Lithium battery notice” in the *ThinkCentre Safety and Warranty Guide* for information about replacing and disposing of the battery.

To replace the battery, do the following:

1. Remove all media from the drives and turn off all attached devices and the computer. Then, disconnect all power cords from electrical outlets and disconnect all cables that are connected to the computer.
2. Open the computer cover. See “Opening the computer cover” on page 72.
3. Locate the battery. See “Locating parts on the system board” on page 71.
4. Remove the old battery.

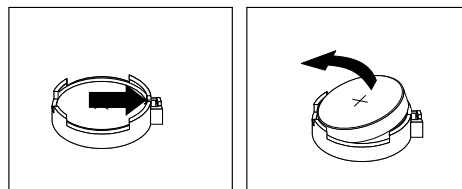

Figure 16. Removing the old battery

5. Install a new battery.

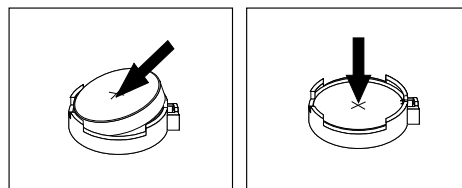

Figure 17. Installing a new battery

6. Reconnect all the cables to the system board and close the computer cover. See “Completing the parts replacement” on page 98.

**Note:** When the computer is turned on for the first time after battery replacement, an error message might be displayed. This is normal after replacing the battery.

7. Turn on the computer and all attached devices.
8. Use the Setup Utility program to set the date, time, and any passwords. See Chapter 6 “Using the Setup Utility program” on page 41.

---

## Replacing the heat sink

**Attention:**

Do not open your computer or attempt any repair before reading and understanding the “Important safety information” in the *ThinkCentre User Guide*. To obtain a copy of the *ThinkCentre User Guide*, go to:  
<http://www.lenovo.com/ThinkCentreUserGuides>

This section provides instructions on how to replace the heat sink.

**CAUTION:**

**The heat sink might be very hot. Turn off the computer and wait three to five minutes to let the computer cool before opening the computer cover.**

To replace the heat sink, do the following:

1. Remove all media from the drives and turn off all attached devices and the computer. Then, disconnect all power cords from electrical outlets and disconnect all cables that are connected to the computer.
2. Open the computer cover. See “Opening the computer cover” on page 72.
3. Locate the heat sink. See “Locating components” on page 71.

4. Follow this sequence to remove the four screws that secure the heat sink to the system board:
  - a. Partially remove screw **1**, then fully remove screw **2**, and then fully remove screw **1**.
  - b. Partially remove screw **3**, then fully remove screw **4**, and then fully remove screw **3**.

**Note:** Carefully remove the four screws from the system board to avoid any possible damage to the system board. The four screws cannot be removed from the heat sink.

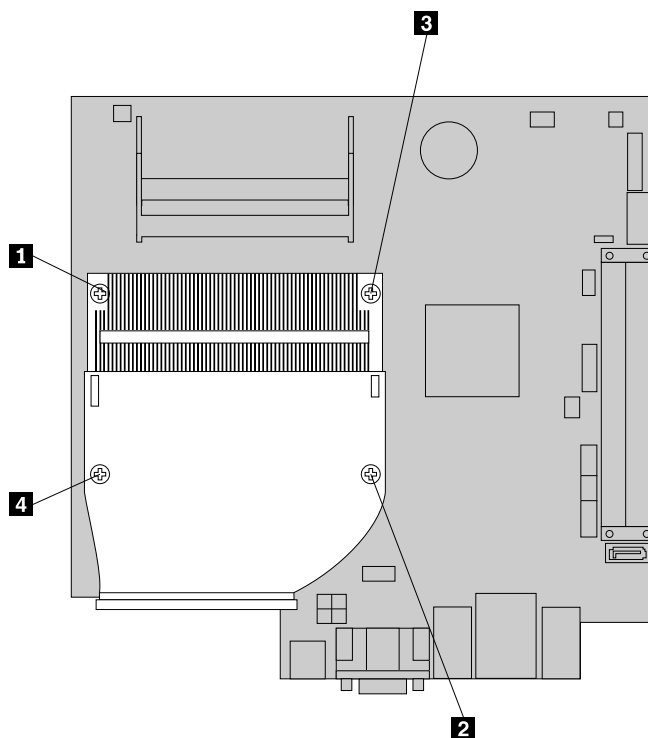

Figure 18. Removing the heat sink

5. Carefully lift the heat sink off the system board.

**Notes:**

- a. You might have to gently twist the heat sink to free it from the microprocessor.
- b. Do not touch the thermal grease while handling the heat sink.
6. Position the new heat sink on the system board so that the four screws are aligned with the holes on the system board.
7. Follow this sequence to install the four screws to secure the new heat sink, as shown in Figure 18 “Removing the heat sink” on page 82:
  - a. Partially tighten screw **1**, then fully tighten screw **2**, and then fully tighten screw **1**.
  - b. Partially tighten screw **3**, then fully tighten screw **4**, and then fully tighten screw **3**.
8. Go to “Completing the parts replacement” on page 98.

---

## Replacing the microprocessor

**Attention:**

Do not open your computer or attempt any repair before reading and understanding the “Important safety information” in the *ThinkCentre User Guide*. To obtain a copy of the *ThinkCentre User Guide*, go to:  
<http://www.lenovo.com/ThinkCentreUserGuides>



This section provides instructions on how to replace the microprocessor.

**CAUTION:**



**The heat sink and microprocessor might be very hot. Turn off the computer and wait three to five minutes to let the computer cool before removing the computer cover.**

To replace the microprocessor, do the following:

1. Remove all media from the drives and turn off all attached devices and the computer. Then, disconnect all power cords from electrical outlets and disconnect all cables that are connected to the computer.
2. Open the computer cover. See “Opening the computer cover” on page 72.
3. Locate the system board and disconnect all cables connected to the system board. See “Locating parts on the system board” on page 71.
4. Press inward on the two side tabs and then pivot the system board to release it from the chassis.

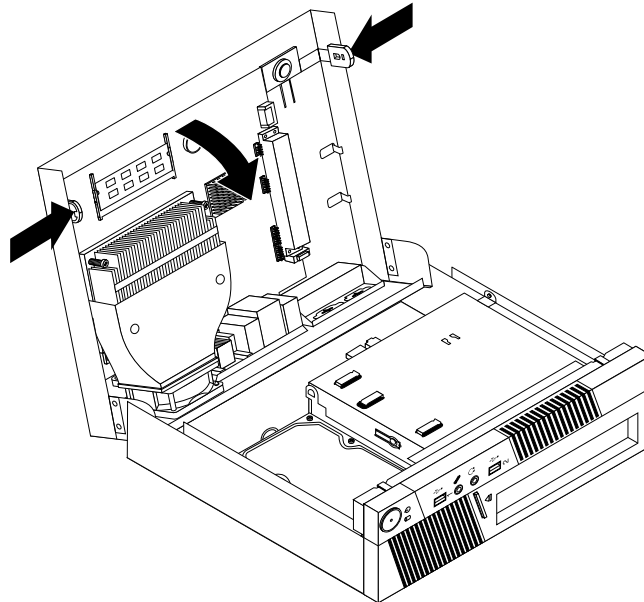

*Figure 19. Releasing the system board*

5. Place the system board on a clean and flat surface.
6. Remove the heat sink. See “Replacing the heat sink” on page 81.

**Note:** Place the heat sink on its side so that the thermal grease on the bottom of it does not get in contact with anything.

7. Lift the small handle **1** and open the retainer **2** to access the microprocessor **3**.

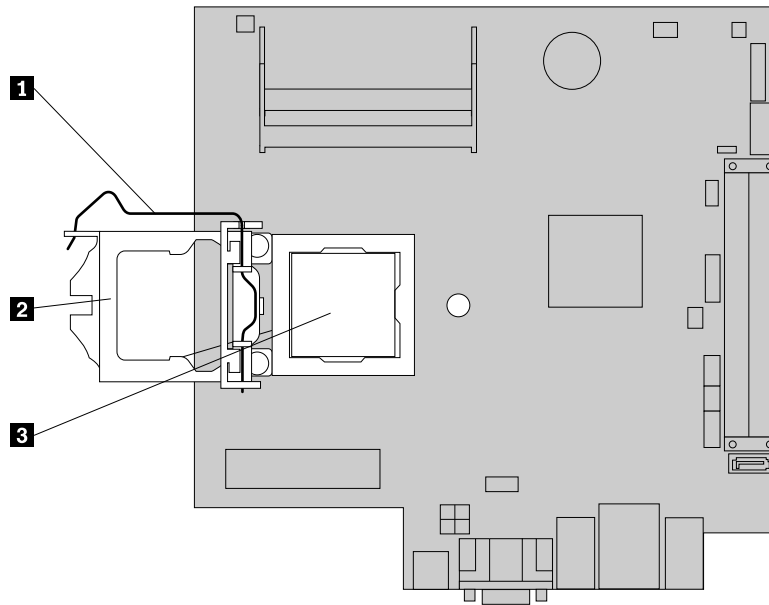

Figure 20. Accessing the microprocessor

8. Lift the microprocessor straight up and out of the microprocessor socket.

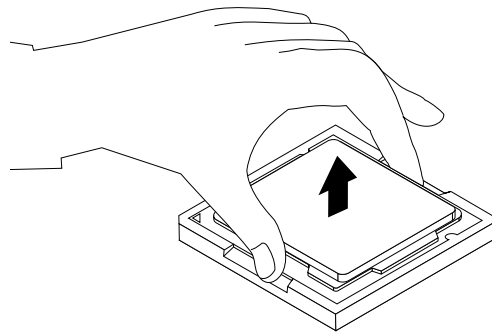
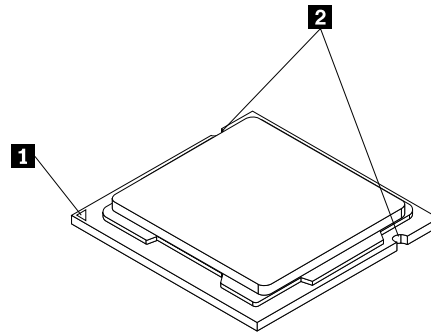

Figure 21. Removing the microprocessor

**Notes:**

- a. Your microprocessor and socket might look different from the one illustrated.

- b. Note the orientation of the microprocessor in the socket. You can either look for the small triangle **1** on one corner of the microprocessor or note the orientation of the notches **2** on the microprocessor. This is important when installing the new microprocessor on the system board.



- c. Touch only the edges of the microprocessor. Do not touch the gold contacts on the bottom.
- d. Do not drop anything onto the microprocessor socket while it is exposed. The socket pins must be kept as clean as possible.
9. Make sure that the small handle is in the raised position and the microprocessor retainer is fully open.
10. Remove the protective cover that protects the gold contacts of the new microprocessor.
11. Hold the new microprocessor by its sides and align the small triangle on one corner of the new microprocessor with the corresponding small triangle on one corner of the microprocessor socket.
12. Lower the new microprocessor straight down into the microprocessor socket on the system board.

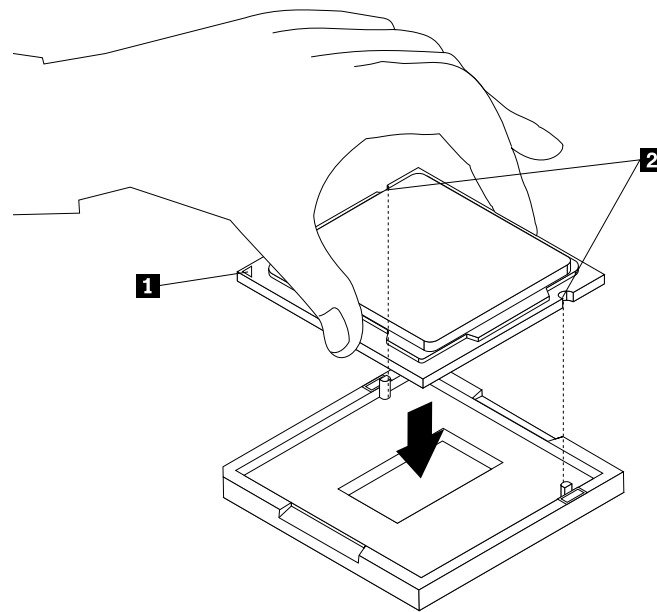

Figure 22. Installing the microprocessor

13. Close the microprocessor retainer and lock it into position with the small handle to secure the new microprocessor in the socket.
14. Reinstall the heat sink. See “Replacing the heat sink” on page 81.
15. Slide the system board to the rear of the chassis and then pivot the system board until it snaps into position.

16. Reconnect all cables that were disconnected from the system board.
17. Go to “Completing the parts replacement” on page 98.

---

## Replacing the system board

**Attention:**

Do not open your computer or attempt any repair before reading and understanding the “Important safety information” in the *ThinkCentre User Guide*. To obtain a copy of the *ThinkCentre User Guide*, go to:  
<http://www.lenovo.com/ThinkCentreUserGuides>

This section provides instructions on how to replace the system board.

**CAUTION:**

**The heat sink and microprocessor might be very hot. Turn off the computer and wait three to five minutes to let the computer cool before opening the computer cover.**

To replace the system board, do the following:

1. Remove all media from the drives and turn off all attached devices and the computer. Then, disconnect all power cords from electrical outlets and disconnect all cables that are connected to the computer.
2. Open the computer cover. See “Opening the computer cover” on page 72.
3. Take notes of the location of all the cable connectors on the system board and then disconnect all the cables. See “Locating parts on the system board” on page 71.
4. Remove the heat sink from the system board. See “Replacing the heat sink” on page 81.
5. Remove the memory modules from the failing system board. See “Installing or replacing a memory module” on page 74.
6. Remove the PCI card from the failing system board. See “Installing or replacing the PCI card” on page 75.
7. Remove the battery from the failing system board. See “Replacing the battery” on page 80.
8. Remove the microprocessor from the failing system board. See “Replacing the microprocessor” on page 82.
9. Remove the four screws that secure the failing system board to the protective cover.

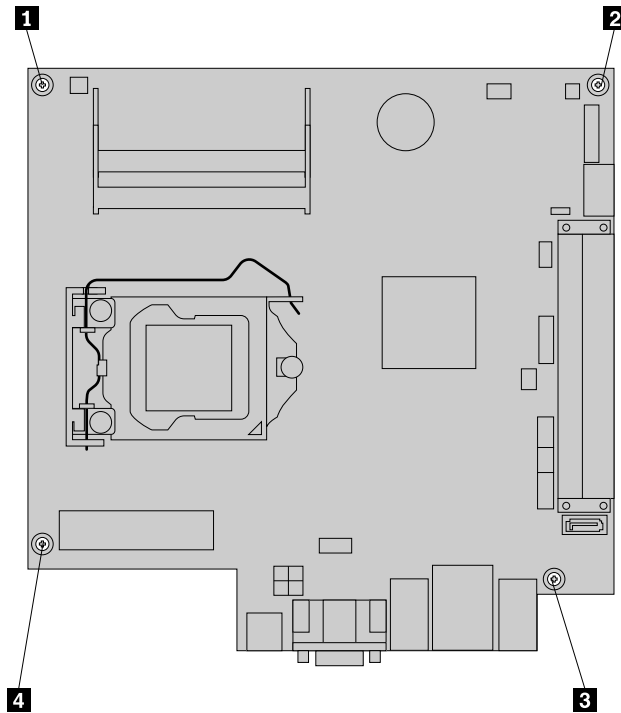

10. Lift the failing system board off the cover.
11. Position the new system board so that the screw holes are aligned with the mounting studs on the cover.
12. Install the screws to secure the new system board to the protective cover.
13. Install the memory modules, PCI card, battery, and microprocessor that you removed from the failing system board to the new system board.
14. Slide the new system board to the rear of the chassis and then pivot it inward until it is locked into position.
15. Connect all the cables to the new system board. See “Locating parts on the system board” on page 71.
16. Install the heat sink to the new system board. See “Replacing the heat sink” on page 81.
17. Go to “Completing the parts replacement” on page 98.

The failing system board must be returned with a microprocessor socket cover to protect the pins during shipping and handling.

To install the microprocessor socket cover, do the following:

1. Release the lever securing the microprocessor retainer and open the retainer to access the microprocessor.
2. Grasp the microprocessor on the sides and lift it straight up and out of the socket. Do not touch the contacts on the microprocessor socket.
3. Note the orientation of the socket cover. Align the notches **1** of the microprocessor socket cover with the alignment keys **2** of the microprocessor socket.
4. Install one side of the socket cover into the microprocessor socket as shown.

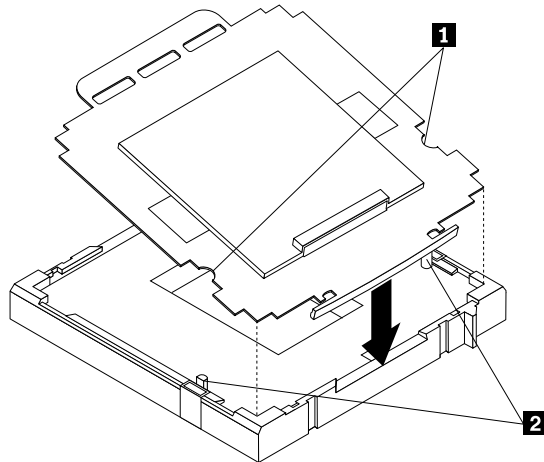

Figure 23. Installing the socket cover

**Note:** Your microprocessor socket and cover might look slightly different from the illustration.

5. Carefully press the other side of the socket cover downwards until the socket cover snaps into place.

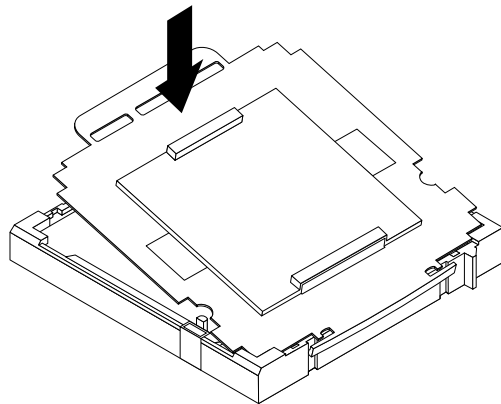

Figure 24. Securing the socket cover

6. Carefully check the four corners of the socket cover to make sure that the cover is secured in the microprocessor socket.
7. Lower the microprocessor retainer and then lower the lever to secure the retainer. Make sure the lever is locked into position.
8. Follow any additional instructions included with the replacement part you received.

---

## Replacing the system fan assembly

**Attention:**

Do not open your computer or attempt any repair before reading and understanding the “Important safety information” in the *ThinkCentre User Guide*. To obtain a copy of the *ThinkCentre User Guide*, go to:  
<http://www.lenovo.com/ThinkCentreUserGuides>

This section provides instructions on how to replace the system fan assembly.

To replace the system fan assembly, do the following:

1. Remove all media from the drives and turn off all attached devices and the computer. Then, disconnect all power cords from electrical outlets and disconnect all cables that are connected to the computer.
2. Open the computer cover. See “Opening the computer cover” on page 72.
3. Locate the system board and disconnect all cables connected to the system board. See “Locating parts on the system board” on page 71.
4. Press inward on the two tabs and then pivot the system board to release it from the chassis.

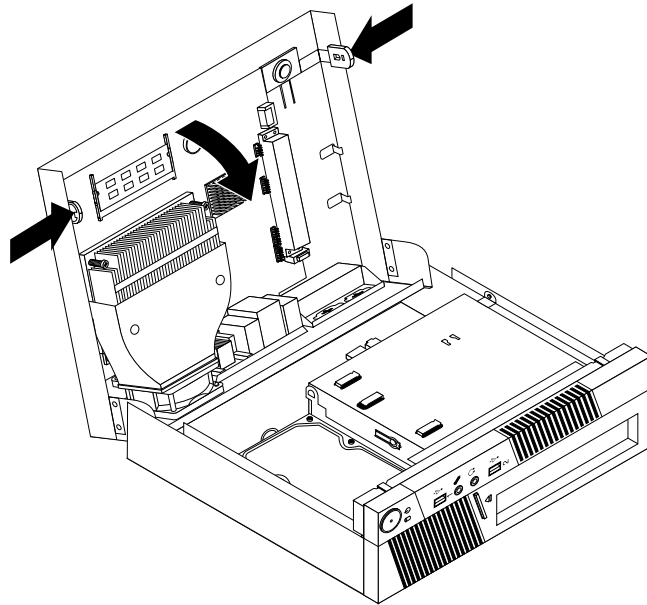

*Figure 25. Releasing the system board*

5. Place the system board on a clean and flat surface.
6. Remove the two rubber mounts from the system fan assembly that connect to the chassis by breaking or cutting them with a pair of scissors. Once this has been done, remove the rubber mounts from the rear of the chassis.

**Note:** When you receive your new system fan assembly, you will receive new rubber mounts.

7. Pull and lift the system fan assembly out of the chassis.

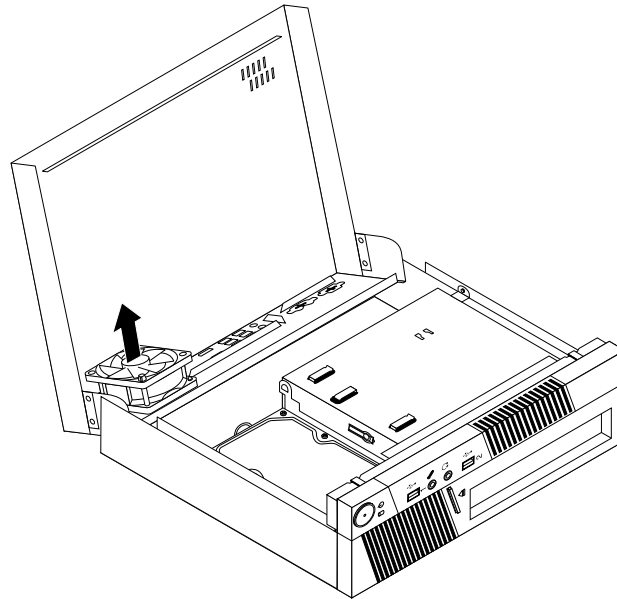
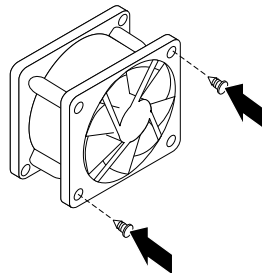

Figure 26. Removing the system fan assembly

8. When installing your new system fan assembly, use the new rubber mounts that come with the new system fan.
9. Install the two short rubber mounts in the new system fan assembly as shown.



10. Install the two long rubber mounts into the rear of the chassis. Push the rubber mounts through the holes of the chassis. If necessary, pull the rubber mounts through the holes from inside the chassis.



11. To install the new system fan assembly into the chassis, align the other two holes in the system fan assembly with the long rubber mounts in the chassis. Pull the rubber mounts through the holes in the system fan assembly until the system fan is in place.

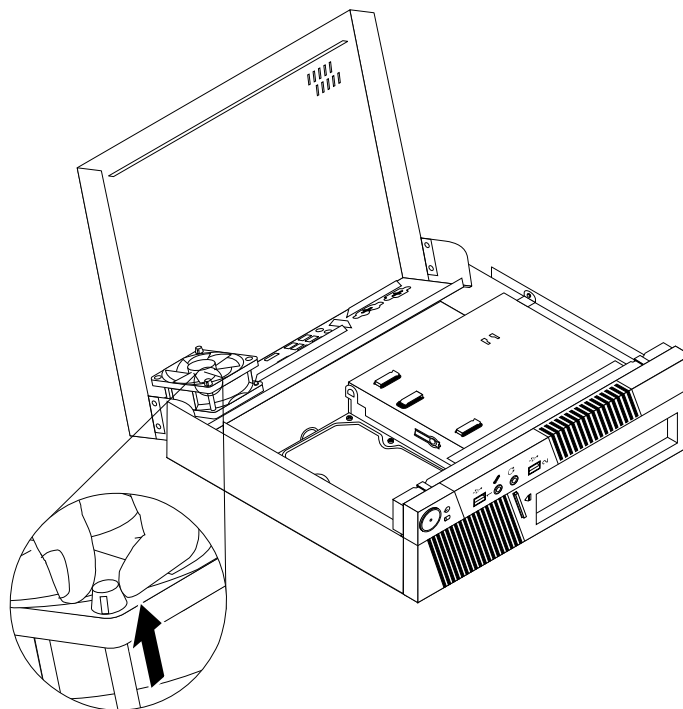

Figure 27. Installing the system fan assembly

12. Slide the system board to the rear of the chassis and then pivot the system board until it snaps into position.
13. Reconnect all cables that were disconnected from the system board.
14. Go to “Completing the parts replacement” on page 98.

---

## Replacing the internal speaker

**Attention:**

Do not open your computer or attempt any repair before reading and understanding the “Important safety information” in the *ThinkCentre User Guide*. To obtain a copy of the *ThinkCentre User Guide*, go to:  
<http://www.lenovo.com/ThinkCentreUserGuides>

This section provides instructions on how to replace the internal speaker.

To replace the internal speaker, do the following:

1. Remove all media from the drives and turn off all attached devices and the computer. Then, disconnect all power cords from electrical outlets and disconnect all cables that are connected to the computer.
2. Open the computer cover. See “Opening the computer cover” on page 72.
3. Locate the internal speaker. See “Locating components” on page 71.
4. Disconnect the internal speaker cable from the system board. See “Locating parts on the system board” on page 71.

5. Press the internal speaker lock latch **1**, slide the internal speaker downwards to remove it from the chassis.

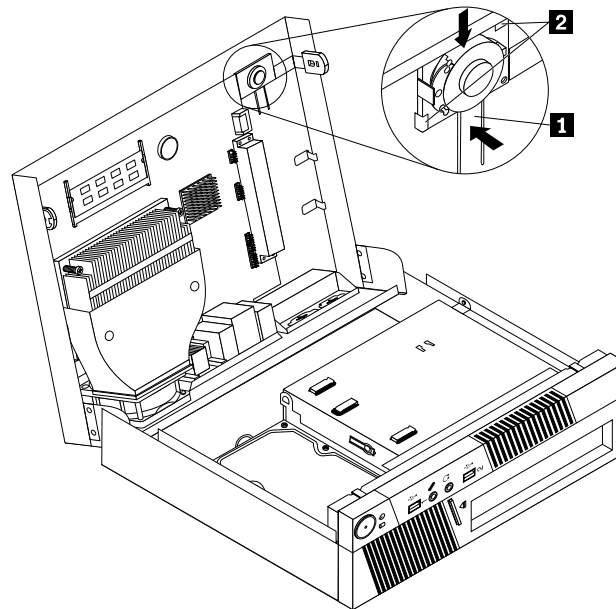

Figure 28. Removing the internal speaker

6. Position the new internal speaker into the metal clips **2** and push the internal speaker upwards until it is secured by the lock latch **1**.
7. Connect the new internal speaker cable to the system board. See “Locating parts on the system board” on page 71.
8. Go to “Completing the parts replacement” on page 98.

---

## Replacing the front audio and USB assembly

**Attention:**

Do not open your computer or attempt any repair before reading and understanding the “Important safety information” in the *ThinkCentre User Guide*. To obtain a copy of the *ThinkCentre User Guide*, go to:  
<http://www.lenovo.com/ThinkCentreUserGuides>

This section provides instructions on how to replace the front audio and USB assembly.

To replace the front audio and USB assembly, do the following:

1. Remove all media from the drives and turn off all attached devices and the computer. Then, disconnect all power cords from electrical outlets and disconnect all cables that are connected to the computer.
2. Open the computer cover. See “Opening the computer cover” on page 72.
3. Remove the front bezel. See “Removing and reinstalling the front bezel” on page 73.
4. Disconnect the front audio and USB assembly cables from the system board and note the cables routing. See “Locating parts on the system board” on page 71.

5. Remove the screw that secures the front audio and USB assembly bracket to the chassis.

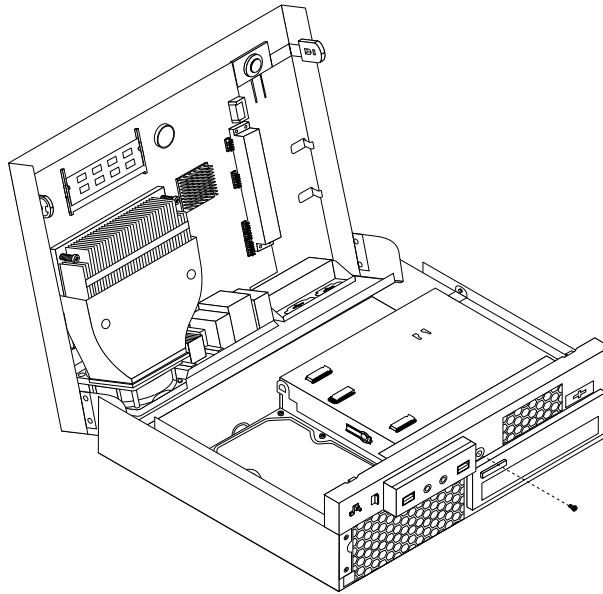

Figure 29. Removing the screw that secures the front audio and USB assembly to the chassis

6. Locate the power switch assembly beside the front audio and USB assembly. Remove the power switch assembly by releasing tab **1** and tab **2** that secure the power switch assembly to the chassis.

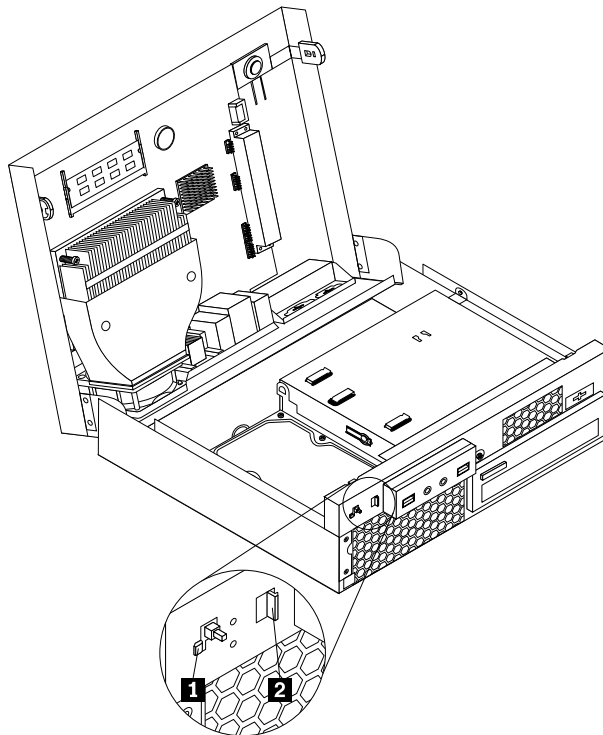

Figure 30. Removing the power switch assembly

7. Completely remove the front audio and USB assembly bracket from the chassis.
8. Remove the two screws that secure the front audio and USB assembly to its bracket and remove the failing front audio and USB assembly from the bracket.
9. Install a new front audio and USB assembly into the bracket and install the two screws to secure the front audio and USB assembly to the bracket.
10. Install the front audio and USB assembly bracket into the chassis and align the screw hole in the bracket with the corresponding hole in the chassis.

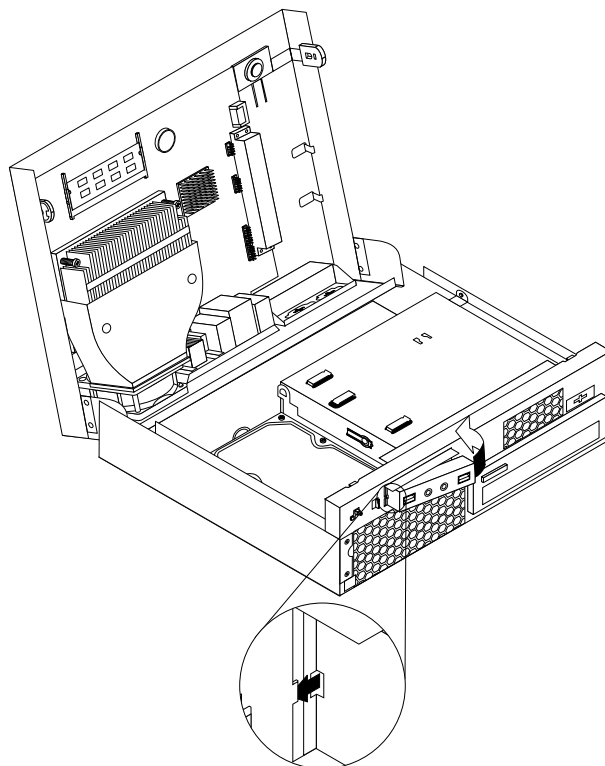

Figure 31. Installing the front audio and USB assembly

11. Install the screw to secure the front audio and USB assembly bracket to the chassis.
12. Install the new power switch assembly into the chassis.
13. Connect the front USB, front panel, and front audio cables to the system board. See “Locating parts on the system board” on page 71.
14. Reinstall the front bezel. See “Removing and reinstalling the front bezel” on page 73.
15. Go to “Completing the parts replacement” on page 98.

---

## Replacing the ac power adapter

**Attention:**

Do not open your computer or attempt any repair before reading and understanding the “Important safety information” in the *ThinkCentre User Guide*. To obtain a copy of the *ThinkCentre User Guide*, go to:  
<http://www.lenovo.com/ThinkCentreUserGuides>

This section provides instructions on how to replace the ac power adapter.

To replace the ac power adapter, do the following:

1. Remove all media from the drives and turn off all attached devices and the computer. Then, disconnect all power cords from electrical outlets and disconnect all cables that are connected to the computer.
2. Disconnect the power cord from the electrical outlet.
3. Disconnect the ac power adapter from the ac power adapter connector on the rear of your computer. See “Locating connectors on the rear of your computer” on page 70.
4. Connect the new ac power adapter to the ac power adapter connector on the chassis and an workable electrical outlet.

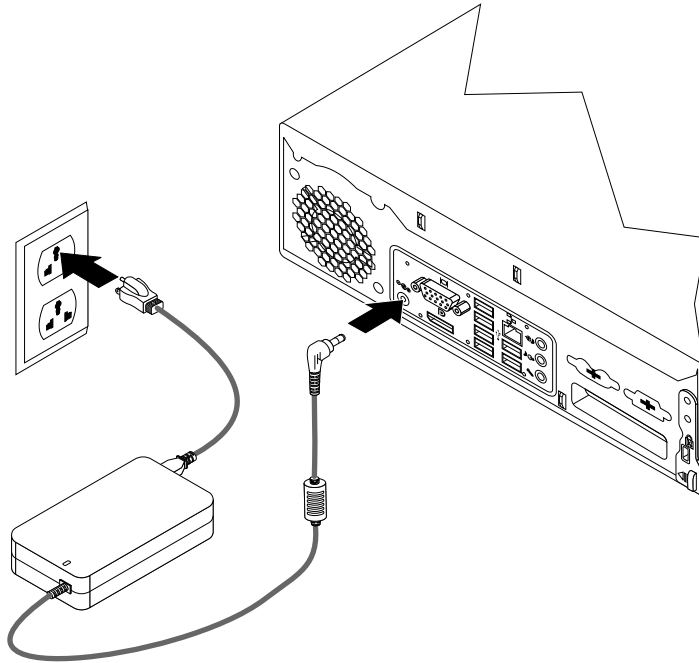

Figure 32. Connecting the ac power adapter

5. Go to “Completing the parts replacement” on page 98.

---

## Replacing the ac power adapter bracket

**Attention:**

Do not open your computer or attempt any repair before reading and understanding the “Important safety information” in the *ThinkCentre User Guide*. To obtain a copy of the *ThinkCentre User Guide*, go to:  
<http://www.lenovo.com/ThinkCentreUserGuides>

This section provides instructions on how to replace the ac power adapter bracket.

To replace the ac power adapter bracket, do the following:

1. Remove any media from the drives and turn off all attached devices and the computer.
2. Disconnect the power cord from the electrical outlet.
3. Disconnect the ac power adapter from the ac power adapter connector on the rear of your computer. See “Locating connectors on the rear of your computer” on page 70.

4. Press the metal clip **1** as shown and then lift the power adapter bracket up to remove it from the chassis.

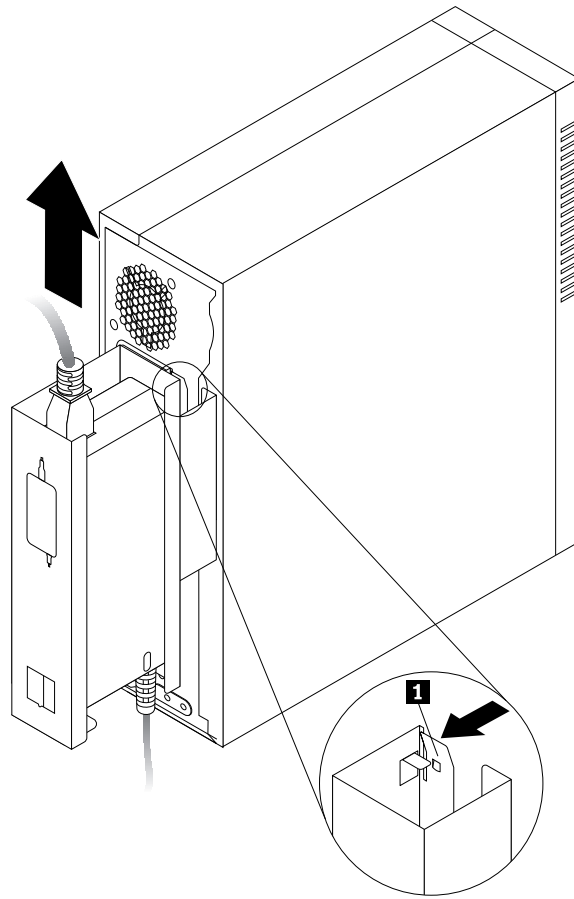

*Figure 33. Removing the ac power adapter bracket*

5. Slide the ac power adapter out of the bracket.

6. Install the ac power adapter into the new power adapter bracket as shown.

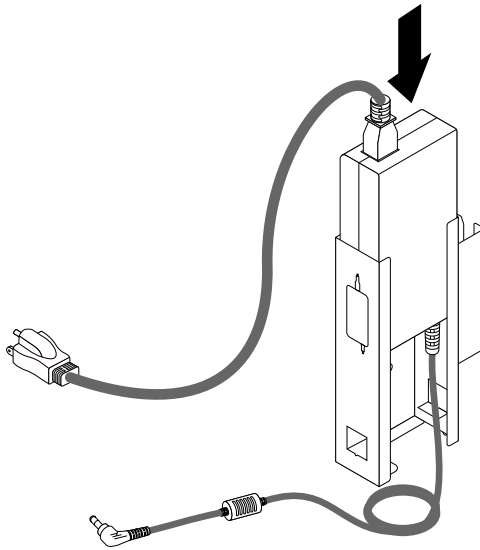

Figure 34. Installing the ac power adapter into the new bracket

7. Insert the two tabs **1** and the tab **2** on the new power adapter bracket into the corresponding holes in the chassis, and then press the new bracket downward to secure the bracket to the chassis.

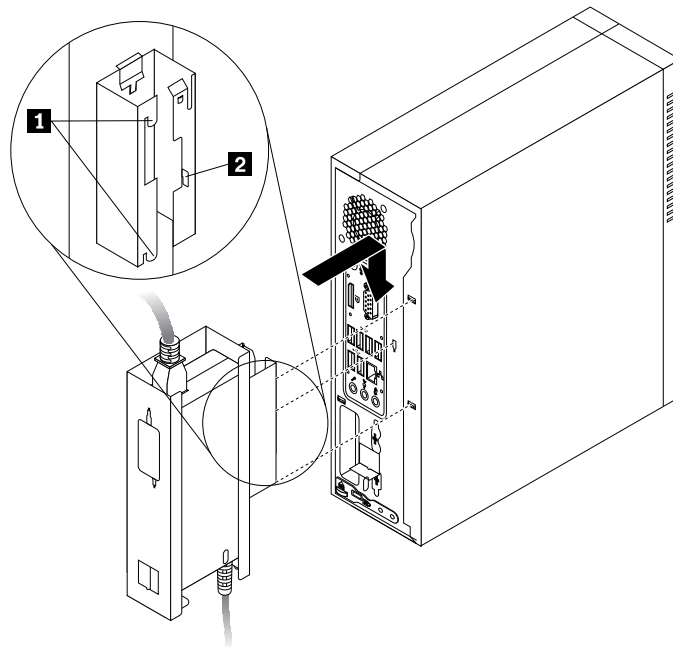

Figure 35. Installing the new ac power adapter bracket

8. Connect the ac power adapter to the ac power adapter connector on the rear of your computer. See “Locating connectors on the rear of your computer” on page 70.
9. Connect the power cord to an workable electrical outlet.
10. Go to “Completing the parts replacement” on page 98.

---

## Completing the parts replacement

After completing the installation or replacement for all parts, you need to close the computer cover and reconnect cables. Depending on the parts you installed or replaced, you might need to confirm the updated information in the Setup Utility program. Refer to Chapter 6 “Using the Setup Utility program” on page 41.

To close the computer cover and reconnect cables to your computer, do the following:

1. Make sure that all components have been reassembled correctly and that no tools or loose screws are left inside your computer. See “Locating components” on page 71 for the locations of various components in your computer.
2. If you have removed the front bezel, reinstall it. See “Removing and reinstalling the front bezel” on page 73.
3. Make sure that the cables are routed correctly. Keep cables clear of the hinges and sides of the computer chassis to avoid interference with closing the computer cover.

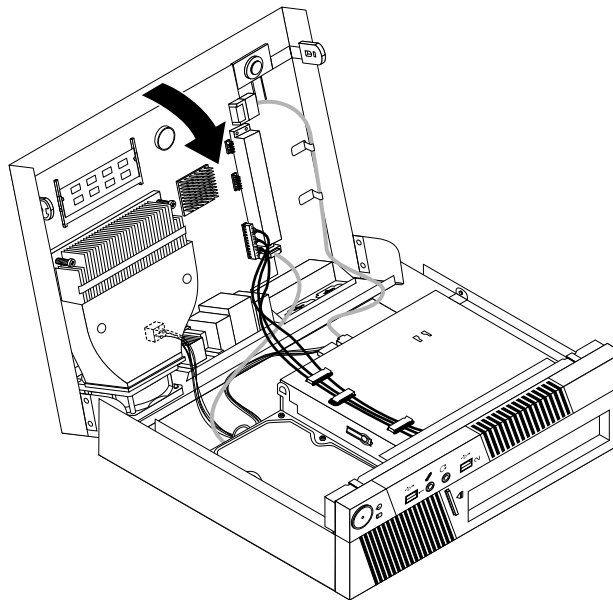

*Figure 36. Cable routing*

4. Close the computer cover as shown.
5. If there is an integrated cable lock available, lock the computer.
6. Reconnect the external cables and power cords to the computer. See “Locating connectors on the rear of your computer” on page 70.
7. To update your configuration, see Chapter 6 “Using the Setup Utility program” on page 41.



---

## Chapter 9. FRU lists

This chapter lists the information on the field replaceable units (FRUs).

**Attention:** Be sure to read and understand all the safety information before replacing any FRUs.

**Note:** In the following tables, a customer replaceable unit (CRU) is identified as either "1", "2", or "N" in the **CRU** column. "N" means that the part is not a CRU, "1" means that the part is a Self-service CRU, and "2" means that the part is an Optional-service CRU.

---

### Overall MT: 0266, 0384, 2491, 4168, 5027, 5067, , and 7519

The following replaceable components are available for the 0266, 0384, 2491, 4168, 5027, 5067, , and 7519 machine type models.

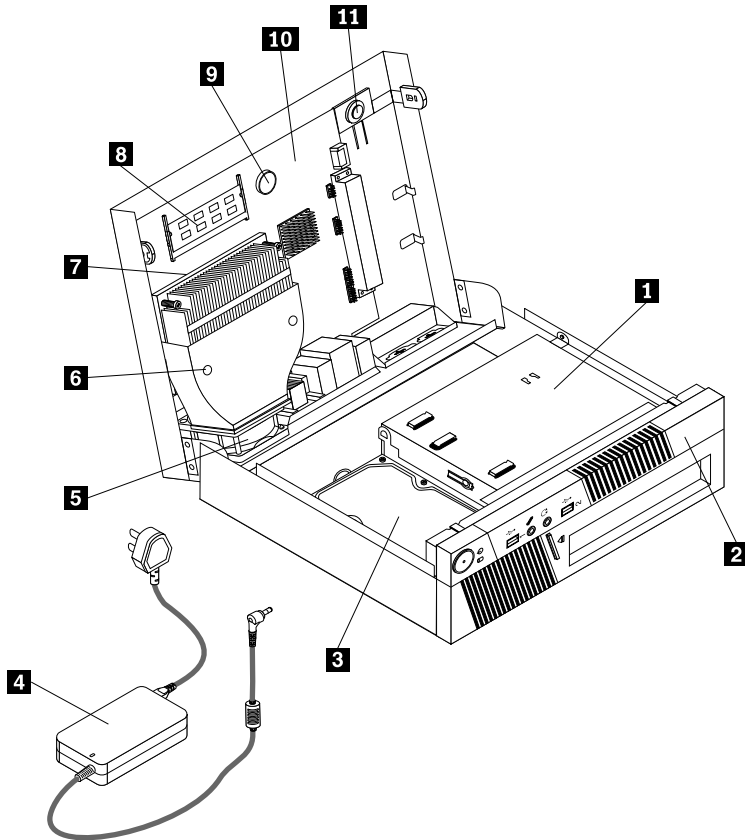

Item #	FRUs	FRU #	CRU
1	<p>Optical drive, DVD-ROM Drive - 16x/48x - SATA</p> <ul style="list-style-type: none"> <li>• MT 0266: A1H A1V A3A A3T C2J C4J C6J A5G A6G B3G D4J D6J</li> <li>• MT 0384: A1G A2G</li> <li>• MT 4168:</li> <li>• MT 5067: A3V</li> <li>• MT 7516: B5M A1H A1V B8J C1J A5G A6G B3G C6J</li> <li>• MT 7519: A7V</li> </ul>	71Y5543	1
1	<p>Optical drive, DVD Recorder Rambo 8 - SATA 12XRAM write</p> <ul style="list-style-type: none"> <li>• MT 0266: B6M B7U B7F B7S B7M B8U B8F B8S B8M A2H A2V A4A A4T B4S B4D B4Y B5S B5D B5Y C8G C9G C3J C5J C7J B9G C1G A7G A8G A9G B1G B2G D1U D1F D1S D2G D3U D3F D3S D5J D7J D8J</li> <li>• MT 0384: A9G A7G A8G A3G A4G A5G A6G</li> <li>• MT 4168: A1G</li> <li>• MT 5067: A2U A2F A2S A2P A2L A2D A2Y A1U A1F A1S A1P A1L A1D A1Y A1G A1M A1A A1Q A1T A1C A1B A1H A1V A1K A1R A1E A1J A3U A3F A3S A3P A3L A3D A3Y A3G A3M A3A A3Q A3T A3C A3B A3H A3R A3E A3J</li> <li>• MT 7516: B6M A2H A2V A3A A3T A4A A4T B4S B4D B4Y B9J C2J B7G AA7G A8G A9G B1G B2G C5U C5F C5S C3J C4J C7J C8J C9J</li> <li>• MT 7519: A1A A1T A2G A3G A4G A5G A6G A8V</li> </ul>	71Y5545	1
2	<p>FRU, front bezel assembly</p> <ul style="list-style-type: none"> <li>• MT 0266: all modles</li> <li>• MT 0384: all modles</li> <li>• MT 4168: all modles</li> <li>• MT 5067: all modles</li> <li>• MT 7516: all modles</li> <li>• MT 7519: all modles</li> </ul>	45K6217	2
3	<p>Hard disk drive, SATA 250GB 7200RPM/3Gb/8M</p> <ul style="list-style-type: none"> <li>• MT 0266: A3A A3T A5G A6G A7G A8G</li> <li>• MT 0384: A9G A1G A2G A3G</li> <li>• MT 4168:</li> <li>• MT 5067: A1U A1F A1S A1P A1L A1D A1Y A1G A1M A1A A1Q A1T A1C A1B A1H A1V A1K A1R A1E A1J</li> <li>• MT 7516: A3A A3T B8J B9J C1J C2J A5G A6G A7G A8G C6J C7J</li> <li>• MT 7519: A1A A1T</li> </ul>	40Y9036	1
3	<p>Hard disk drive, SATA 250GB 7200RPM/3Gb/8M</p> <ul style="list-style-type: none"> <li>• MT 0266: A3A A3T A5G A6G A7G A8G</li> <li>• MT 0384: A9G A1G A2G A3G</li> <li>• MT 4168:</li> <li>• MT 5067: A1U A1F A1S A1P A1L A1D A1Y A1G A1M A1A A1Q A1T A1C A1B A1H A1V A1K A1R A1E A1J</li> <li>• MT 7516: A3A A3T B8J B9J C1J C2J A5G A6G A7G A8G C6J C7J</li> <li>• MT 7519: A1A A1T</li> </ul>	45K0408	1

Item #	FRUs	FRU #	CRU
3	<p>Hard disk drive, SATA 320GB 7200 RPM/3Gb/8M</p> <ul style="list-style-type: none"> <li>• MT 0266: B6M B7U B7F B7S B7M A4A A4T C8G C2J C3J C4J C5J C6J C7J B9G C1G D4J D5J D6J D7J D8J</li> <li>• MT 0384: A7G A8G</li> <li>• MT 4168: A1G</li> <li>• MT 5067: A3V A3U A3F A3S A3P A3L A3D A3Y A3G A3M A3A A3Q A3T A3C A3B A3H A3R A3E A3J</li> <li>• MT 7516: B5M A4A A4T B7G C5U C5F C5S C3J C4J C8J C9J</li> <li>• MT 7519: A2G A3G A4G A5G A7V</li> </ul>	87H4891	1
3	<p>Hard disk drive, SATA 320GB 7200 RPM/3Gb/8M</p> <ul style="list-style-type: none"> <li>• MT 0266: B6M B7U B7F B7S B7M A4A A4T C8G C2J C3J C4J C5J C6J C7J B9G C1G D4J D5J D6J D7J D8J</li> <li>• MT 0384: A7G A8G</li> <li>• MT 4168: A1G</li> <li>• MT 5067: A3V A3U A3F A3S A3P A3L A3D A3Y A3G A3M A3A A3Q A3T A3C A3B A3H A3R A3E A3J</li> <li>• MT 7516: B5M A4A A4T B7G C5U C5F C5S C3J C4J C8J C9J</li> <li>• MT 7519: A2G A3G A4G A5G A7V</li> </ul>	45K0409	1
3	<p>Hard disk drive, SATA 500GB 7200RPM/3Gb/16M</p> <ul style="list-style-type: none"> <li>• MT 0266: B8U B8F B8S B8M A1H A1V A2H A2V B4S B4D B4Y B5S B5D B5Y C9G A9G B1G B2G B3G D1U D1F D1S D2G D3U D3F D3S</li> <li>• MT 0384: A4G A5G A6G</li> <li>• MT 4168:</li> <li>• MT 5067: A2U A2F A2S A2P A2L A2D A2Y</li> <li>• MT 7516: B6M A1H A1V A2H A2V B4S B4D B4Y A9G B1G B2G B3G</li> <li>• MT 7519: A6G A8V</li> </ul>	41X5582	1
3	<p>Hard disk drive, SATA 500GB 7200RPM/3Gb/16M</p> <ul style="list-style-type: none"> <li>• MT 0266: B8U B8F B8S B8M A1H A1V A2H A2V B4S B4D B4Y B5S B5D B5Y C9G A9G B1G B2G B3G D1U D1F D1S D2G D3U D3F D3S</li> <li>• MT 0384: A4G A5G A6G</li> <li>• MT 4168:</li> <li>• MT 5067: A2U A2F A2S A2P A2L A2D A2Y</li> <li>• MT 7516: B6M A1H A1V A2H A2V B4S B4D B4Y A9G B1G B2G B3G</li> <li>• MT 7519: A6G A8V</li> </ul>	45K0410	1
3	<p>Hard disk drive, SATA 1TB 7200RPM/3Gb/32M</p> <ul style="list-style-type: none"> <li>• MT 0266:</li> <li>• MT 0384:</li> <li>• MT 4168:</li> <li>• MT 5067:</li> <li>• MT 7516:</li> <li>• MT 7519:</li> </ul>	45K0412	1

Item #	FRUs	FRU #	CRU
3	<p>Hard disk drive, SATAIII 250GB 7200RPM/6Gb/16M</p> <ul style="list-style-type: none"> <li>• MT 0266:</li> <li>• MT 0384:</li> <li>• MT 4168:</li> <li>• MT 5067:</li> <li>• MT 7516: A3A A3T B8J B9J C1J C2J A5G A6G A7G A8G C6J C7J</li> <li>• MT 7519: A1A A1T</li> </ul>	03T7039	1
3	<p>Hard disk drive, SATAIII 320GB 7200RPM/6Gb/16M</p> <ul style="list-style-type: none"> <li>• MT 0266: B6M B7U B7F B7S B7M A4A A4T C8G C2J C3J C4J C5J C6J C7J B9G C1G D4J D5J D6J D7J D8J</li> <li>• MT 0384:</li> <li>• MT 4168:</li> <li>• MT 5067: A3V A3U A3F A3S A3P A3L A3D A3Y A3G A3M A3A A3Q A3T A3C A3B A3H A3R A3E A3J</li> <li>• MT 7516: B5M A4A A4T B7G C5U C5F C5S C3J C4J C8J C9J</li> <li>• MT 7519: A2G A3G A4G A5G A7V</li> </ul>	03T7040	1
3	<p>Hard disk drive, SATAIII 500GB 7200RPM/6Gb/16M</p> <ul style="list-style-type: none"> <li>• MT 0266: B8U B8F B8S B8M A1H A1V A2H A2V B4S B4D B4Y B5S B5D B5Y C9G A9G B1G B2G B3G D1U D1F D1S D2G D3U D3F D3S</li> <li>• MT 0384:</li> <li>• MT 4168:</li> <li>• MT 5067:</li> <li>• MT 7516:</li> <li>• MT 7519: A6G A8V</li> </ul>	03T7041	1
3	<p>Hard disk drive, SATAIII 1TB 7200RPM/6Gb/32M</p> <ul style="list-style-type: none"> <li>• MT 0266:</li> <li>• MT 0384:</li> <li>• MT 4168:</li> <li>• MT 5067:</li> <li>• MT 7516:</li> <li>• MT 7519:</li> </ul>	03T7042	1
3	<p>Hard disk drive, 2.5 inch SSD 160G SSD</p> <ul style="list-style-type: none"> <li>• MT 0266:</li> <li>• MT 0384:</li> <li>• MT 4168:</li> <li>• MT 5067:</li> <li>• MT 7516:</li> <li>• MT 7519:</li> </ul>	45K0616	1

Item #	FRUs	FRU #	CRU
3	<p>Hard disk drive, 2.5 inch 300G 10K RPM HDD</p> <ul style="list-style-type: none"> <li>• MT 0266:</li> <li>• MT 0384:</li> <li>• MT 4168:</li> <li>• MT 5067:</li> <li>• MT 7516:</li> <li>• MT 7519:</li> </ul>	91Y1657	1
4	<p>Power supply, 150W power adapter</p> <ul style="list-style-type: none"> <li>• MT 0266: B6M B7U B7F B7S B7M B8U B8F B8S B8M A1H A1V A2H A2V A3A A3T A4A A4T B4S B4D B4Y B5S B5D B5Y C8G C9G C2J C3J C4J C5J C6J C7J B9G C1G A5G A6G A7G A8G A9G B1G B2G B3G D1U D1F D1S D2G D3U D3F D3S D4J D5J D6J D7J D8J</li> <li>• MT 0384: A9G A7G A8G A1G A2G A3G A4G A5G A6G</li> <li>• MT 4168: A1G</li> <li>• MT 5067: A2U A2F A2S A2P A2L A2D A2Y A1U A1F A1S A1P A1L A1D A1Y A1G A1M A1A A1Q A1T A1C A1B A1H A1V A1K A1R A1E A1J A3V A3U A3F A3S A3P A3L A3D A3Y A3G A3M A3A A3Q A3T A3C A3B A3H A3R A3E A3J</li> <li>• MT 7516: B5M B6M A1H A1V A2H A2V A3A A3T A4A A4T B4S B4D B4Y B8J B9J C1J C2J B7G A5G A6G A7G A8G A9G B1G B2G B3G C5U C5F C5S C3J C4J C6J C7J C8J C9J</li> <li>• MT 7519: A1A A1T A2G A3G A4G A5G A6G A7V A8V</li> </ul>	54Y8838	2
5	<p>System fan, 4.8L system fan (processor)</p> <ul style="list-style-type: none"> <li>• MT 0266: all modles</li> <li>• MT 0384: all modles</li> <li>• MT 4168: all modles</li> <li>• MT 5067: all modles</li> <li>• MT 7516: all modles</li> <li>• MT 7519: all modles</li> </ul>	03T9542	1
7	<p>Microprocessor, Ci5 2390T Sandy Bridge stepping Q0 3MB 2c FCLGA 2.7GHZ 35W vPro</p> <ul style="list-style-type: none"> <li>• MT 0266:</li> <li>• MT 0384:</li> <li>• MT 4168:</li> <li>• MT 5067:</li> <li>• MT 7516:</li> <li>• MT 7519:</li> </ul>	03T8034	N

Item #	FRUs	FRU #	CRU
7	<p>Microprocessor, Ci3 2100 Sandy Bridge stepping Q0 3MB 2c FCLGA 3.1GHZ 65W</p> <ul style="list-style-type: none"> <li>• MT 0266:</li> <li>• MT 0384:</li> <li>• MT 4168:</li> <li>• MT 5067:</li> <li>• MT 7516: B5M B6M A1H A1V A2H A2V A3A A3T A4A A4T B4S B4D B4Y B8J B9J C1J C2J B7G A5G A6G A7G A8G A9G B1G B2G B3G C5U C5F C5S C3J C4J C6J C7J C8J C9J</li> <li>• MT 7519: A1A A1T A2G A4G</li> </ul>	03T8011	N
7	<p>Microprocessor, Ci3 2120 Sandy Bridge stepping Q0 3MB 2c FCLGA 3.3GHZ 65W</p> <ul style="list-style-type: none"> <li>• MT 0266:</li> <li>• MT 0384:</li> <li>• MT 4168:</li> <li>• MT 5067:</li> <li>• MT 7516:</li> <li>• MT 7519: A6G</li> </ul>	03T8010	N
7	<p>Microprocessor, Ci3 2100T Sandy Bridge stepping Q0 3MB 2c FCLGA 2.5GHZ 35W</p> <ul style="list-style-type: none"> <li>• MT 0266:</li> <li>• MT 0384:</li> <li>• MT 4168:</li> <li>• MT 5067:</li> <li>• MT 7516:</li> <li>• MT 7519:</li> </ul>	03T8033	N
7	<p>Microprocessor, Ci7 2600S Sandy Bridge stepping D2 8MB 4c FCLGA 2.8GHZ 65W vPro</p> <ul style="list-style-type: none"> <li>• MT 0266:</li> <li>• MT 0384:</li> <li>• MT 4168:</li> <li>• MT 5067:</li> <li>• MT 7516:</li> <li>• MT 7519:</li> </ul>	03T8015	N
7	<p>Microprocessor, Ci5 2500S Sandy Bridge stepping D2 6MB 4c FCLGA 2.7GHZ 65W vPro</p> <ul style="list-style-type: none"> <li>• MT 0266: D3U D3F D3S D4J D5J D6J</li> <li>• MT 0384:</li> <li>• MT 4168:</li> <li>• MT 5067:</li> <li>• MT 7516:</li> <li>• MT 7519:</li> </ul>	03T8016	N

Item #	FRUs	FRU #	CRU
7	<p>Microprocessor, Ci5 2400S Sandy Bridge stepping D2 6MB 4c FCLGA 2.5GHZ 65W vPro</p> <ul style="list-style-type: none"> <li>• MT 0266: B6M B7U B7F B7S B7M B8U B8F B8S B8M A1H A1V A2H A2V A3A A3T A4A A4T B4S B4D B4Y B5S B5D B5Y C8G C9G C2J C3J C4J C5J C6J C7J B9G C1G A5G A6G A7G A8G A9G B1G B2G B3G D1U D1F D1S D2G D7J D8J</li> <li>• MT 0384: A9G A7G A8G A1G A2G A3G A4G A5G A6G</li> <li>• MT 4168: A1G</li> <li>• MT 5067: A2U A2F A2S A2P A2L A2D A2Y A1U A1F A1S A1P A1L A1D A1Y A1G A1M A1A A1Q A1T A1C A1B A1H A1V A1K A1R A1E A1J A3V A3U A3F A3S A3P A3L A3D A3Y A3G A3M A3A A3Q A3T A3C A3B A3H A3R A3E A3J</li> <li>• MT 7516:</li> <li>• MT 7519:</li> </ul>	03T8017	N
7	<p>Microprocessor, Ci5 2500T Sandy Bridge stepping D2 6MB 4c FCLGA 2.30GHZ 45W vPro</p> <ul style="list-style-type: none"> <li>• MT 0266:</li> <li>• MT 0384:</li> <li>• MT 4168:</li> <li>• MT 5067:</li> <li>• MT 7516:</li> <li>• MT 7519:</li> </ul>	03T8018	N
7	<p>Microprocessor, G620 Sandy Bridge stepping Q-0 3MB 2c FCLGA 2.6GHz 65W</p> <ul style="list-style-type: none"> <li>• MT 0266:</li> <li>• MT 0384:</li> <li>• MT 4168:</li> <li>• MT 5067:</li> <li>• MT 7516:</li> <li>• MT 7519: A3G</li> </ul>	03T6226	N
7	<p>Microprocessor, G840 Sandy Bridge stepping Q-0 3MB 2c FCLGA 2.8GHz 65W</p> <ul style="list-style-type: none"> <li>• MT 0266:</li> <li>• MT 0384:</li> <li>• MT 4168:</li> <li>• MT 5067:</li> <li>• MT 7516:</li> <li>• MT 7519: A5G A7V A8V</li> </ul>	03T6225	N
7	<p>Microprocessor, G850 Sandy Bridge stepping Q-0 3MB 2c FCLGA 2.9GHz 65W</p> <ul style="list-style-type: none"> <li>• MT 0266:</li> <li>• MT 0384:</li> <li>• MT 4168:</li> <li>• MT 5067:</li> <li>• MT 7516:</li> <li>• MT 7519:</li> </ul>	03T6224	N

Item #	FRUs	FRU #	CRU
7	Microprocessor, Core i3-2125 Sandy Bridge , 3MB 2C/4T 3.30 GHz, 65W <ul style="list-style-type: none"> <li>• MT 0266:</li> <li>• MT 0384:</li> <li>• MT 4168:</li> <li>• MT 5067:</li> <li>• MT 7516:</li> <li>• MT 7519:</li> </ul>	03T8357	N
7	Microprocessor, Core i3-2130 Sandy Bridge , 3MB 2C/4T 3.40 GHz, 65W <ul style="list-style-type: none"> <li>• MT 0266:</li> <li>• MT 0384:</li> <li>• MT 4168:</li> <li>• MT 5067:</li> <li>• MT 7516:</li> <li>• MT 7519:</li> </ul>	03T8358	N
7	Microprocessor, G630 Sandy Bridge , 3MB, 2C/2T 2.7GHz, 65W <ul style="list-style-type: none"> <li>• MT 0266:</li> <li>• MT 0384: A9G A7G A8G A1G A2G A3G A4G A5G A6G</li> <li>• MT 4168: A1G</li> <li>• MT 5067: A1U A1F A1S A1P A1L A1D A1Y A1G A1M A1A A1Q A1T A1C A1B A1H A1V A1K A1R A1E A1J A3V</li> <li>• MT 7516: A1H A1V A2H A2V A3A A3T A4A A4T B4S B4D B4Y B8J B9J C1J C2J B7G A5G A6G A7G A8G A9G B1G B2G B3G C3J C4J C6J C7J C8J C9J</li> <li>• MT 7519: A1A A1T A2G A3G A4G A5G A7V A8V</li> </ul>	03T8360	N
7	Microprocessor, G860 Sandy Bridge , 3MB, 2C/2T 3.0GHz, 65W <ul style="list-style-type: none"> <li>• MT 0266:</li> <li>• MT 0384:</li> <li>• MT 4168:</li> <li>• MT 5067: A2U A2F A2S A2P A2L A2D A2Y A1U A1F A1S A1P A1L A1D A1Y A1G A1M A1A A1Q A1T A1C A1B A1H A1V A1K A1R A1E A1J A3U A3F A3S A3P A3L A3D A3Y A3G A3M A3A A3Q A3T A3C A3B A3H A3R A3E A3J</li> <li>• MT 7516: B5M B6M C5U C5F C5S</li> <li>• MT 7519: A6G</li> </ul>	03T8361	N
7	Microprocessor, G540 Sandy Bridge 2MB 2c FCLGA 2.5GHz 65W <ul style="list-style-type: none"> <li>• MT 0266:</li> </ul>	03T8354	N
7	Microprocessor, G530 Sandy Bridge 2MB 2c FCLGA 2.5GHz 65W <ul style="list-style-type: none"> <li>• MT 0266:</li> </ul>	03T8356	N
7	Microprocessor, G440 Sandy Bridge 1MB 2c FCLGA 1.6GHz 35W <ul style="list-style-type: none"> <li>• MT 0266:</li> </ul>	03T8355	N



Item #	FRUs	FRU #	CRU
8	Memory module, 1GB PC3-10600 1333MHz DDR3 SoDIMM <ul style="list-style-type: none"> <li>• MT 0266:</li> <li>• MT 0384:</li> <li>• MT 4168:</li> <li>• MT 5067:</li> <li>• MT 7516:</li> <li>• MT 7519:</li> </ul>	64Y6650	1
8	Memory module, 2GB PC3-10600 1333MHz DDR3 SoDIMM <ul style="list-style-type: none"> <li>• MT 0266: A1H A1V A2H A2V A3A A3T A4A A4T B4S B4D B4Y B5S B5D B5Y C8G C9G C2J C3J C4J C5J B9G C1G A5G A6G A7G A8G A9G B1G B2G B3G D2G D6J D7J D8J</li> <li>• MT 0384: A9G A7G A8G A1G A2G A3G A4G A5G A6G</li> <li>• MT 4168: A1G</li> <li>• MT 5067: A1U A1F A1S A1P A1L A1D A1Y A1G A1M A1A A1Q A1T A1C A1B A1H A1V A1K A1R A1E A1J A3V</li> <li>• MT 7516: A1H A1V A2H A2V A3A A3T A4A A4T B4S B4D B4Y B8J B9J C1J C2J B7G A5G A6G A7G A8G A9G B1G B2G B3G C3J C4J C6J C7J C8J C9J</li> <li>• MT 7519: A1A A1T A2G A3G A4G A5G A7V A8V</li> </ul>	64Y6651	1
8	Memory module, 4GB PC3-10600 1333MHz DDR3 SoDIMM <ul style="list-style-type: none"> <li>• MT 0266: B6M B7U B7F B7S B7M B8U B8F B8S B8M C6J C7J D1U D1F D1S D3U D3F D3S D4J D5J</li> <li>• MT 0384:</li> <li>• MT 4168:</li> <li>• MT 5067: A2U A2F A2S A2P A2L A2D A2Y A1U A1F A1S A1P A1L A1D A1Y A1G A1M A1A A1Q A1T A1C A1B A1H A1V A1K A1R A1E A1J A3U A3F A3S A3P A3L A3D A3Y A3G A3M A3A A3Q A3T A3C A3B A3H A3R A3E A3J</li> <li>• MT 7516: B5M B6M C5U C5F C5S</li> <li>• MT 7519: A6G</li> </ul>	89Y9225	1
10	System board, planar Intel Q67 B3 PRQ without LAN surge planar for WW except Russia <ul style="list-style-type: none"> <li>• MT 0266: B6M B7U B7F B7S B7M B8U B8F B8S B8M A1H A1V A2H A2V A3A A3T A4A A4T B4S B4D B4Y B5S B5D B5Y C8G C9G C2J C3J C4J C5J C6J C7J B9G C1G A5G A6G A7G A8G A9G B1G B2G B3G D1U D1F D1S D2G D3U D3F D3S D4J D5J D6J D7J D8J</li> <li>• MT 0384: A9G A7G A8G A1G A2G A3G A4G A5G A6G</li> <li>• MT 4168: A1G</li> <li>• MT 5067: A2U A2F A2S A2P A2L A2D A2Y A1U A1F A1S A1P A1L A1D A1Y A1G A1M A1A A1Q A1T A1C A1B A1H A1V A1K A1R A1E A1J A3V A3U A3F A3S A3P A3L A3D A3Y A3G A3M A3A A3Q A3T A3C A3B A3H A3R A3E A3J</li> <li>• MT 7516: B5M B6M A1H A1V A2H A2V A3A A3T A4A A4T B4S B4D B4Y B8J B9J C1J C2J B7G A5G A6G A7G A8G A9G B1G B2G B3G C5U C5F C5S C3J C4J C6J C7J C8J C9J</li> <li>• MT 7519: A1A A1T A2G A3G A4G A5G A6G A7V A8V</li> </ul>	03T8007	N
10	System board, Q67 planar without LAN surge planar-special bid-Russia only <ul style="list-style-type: none"> <li>• MT 0266: A5G A6G A7G A8G A9G B1G B2G B3G D2G</li> <li>• MT 0384: A9G A7G A8G A1G A2G A3G A4G A5G A6G</li> </ul>	03T8008	N

Item #	FRUs	FRU #	CRU
	<ul style="list-style-type: none"> <li>• MT 4168: A1G</li> <li>• MT 5067: A1G A3G</li> <li>• MT 7516:</li> <li>• MT 7519:</li> </ul>		

## Mechanical FRUs

Mechanical FRUs	FRU #	CRU
FRU, 4.8L Intel 65W thermal kit <ul style="list-style-type: none"> <li>• MT 0266: all models</li> <li>• MT 0384: all models</li> <li>• MT 4168: all models</li> <li>• MT 5067: all models</li> <li>• MT 7516: all models</li> <li>• MT 7519: all models</li> </ul>	03T7055	2
FRU, power cable for ODD&HDD_R_150+150mm <ul style="list-style-type: none"> <li>• MT 0266: all models</li> <li>• MT 0384: all models</li> <li>• MT 4168: all models</li> <li>• MT 5067: all models</li> <li>• MT 7516: all models</li> <li>• MT 7519: all models</li> </ul>	45J9583	2
FRU, SATA cable - HDD 250mm, 2 latching <ul style="list-style-type: none"> <li>• MT 0266: all models</li> <li>• MT 0384: all models</li> <li>• MT 4168: all models</li> <li>• MT 5067: all models</li> <li>• MT 7516: all models</li> <li>• MT 7519: all models</li> </ul>	54Y9929	2
FRU, Internal speaker <ul style="list-style-type: none"> <li>• MT 0266: all models</li> <li>• MT 0384: all models</li> <li>• MT 4168: all models</li> <li>• MT 5067: all models</li> <li>• MT 7516: all models</li> <li>• MT 7519: all models</li> </ul>	43N9092	2

Mechanical FRUs	FRU #	CRU
FRU, Front I/O cable_NC_ESD_R(4.8L_PCBA_A350_U350_FP430) <ul style="list-style-type: none"> <li>• MT 0266: all models</li> <li>• MT 0384: all models</li> <li>• MT 4168: all models</li> <li>• MT 5067: all models</li> <li>• MT 7516: all models</li> <li>• MT 7519: all models</li> </ul>	45J9567	2
FRU, second serial port cable 250mm (with level shift IC) <ul style="list-style-type: none"> <li>• MT 0266: all models</li> <li>• MT 0384: all models</li> <li>• MT 4168: all models</li> <li>• MT 5067: all models</li> <li>• MT 7516: all models</li> <li>• MT 7519: all models</li> </ul>	71Y6217	2
FRU, C2 chassis Intrusion cable, 350mm <ul style="list-style-type: none"> <li>• MT 0266: all models</li> <li>• MT 0384: all models</li> <li>• MT 4168: all models</li> <li>• MT 5067: all models</li> <li>• MT 7516: all models</li> <li>• MT 7519: all models</li> </ul>	43N9093	2
FRU, rear USB cable_R_200mm_LP <ul style="list-style-type: none"> <li>• MT 0266: all models</li> <li>• MT 0384: all models</li> <li>• MT 4168: all models</li> <li>• MT 5067: all models</li> <li>• MT 7516: all models</li> <li>• MT 7519: all models</li> </ul>	42Y8006	2
FRU, e-SATA cable_R_300mm_LP <ul style="list-style-type: none"> <li>• MT 0266: all models</li> <li>• MT 0384: all models</li> <li>• MT 4168: all models</li> <li>• MT 5067: all models</li> <li>• MT 7516: all models</li> <li>• MT 7519: all models</li> </ul>	41R3311	2

Mechanical FRUs	FRU #	CRU
FRU, PS2 cable (170mm) <ul style="list-style-type: none"> <li>• MT 0266: all models</li> <li>• MT 0384: all models</li> <li>• MT 4168: all models</li> <li>• MT 5067: all models</li> <li>• MT 7516: all models</li> <li>• MT 7519: all models</li> </ul>	43N9149	2
FRU, ODD blank bezel, plastic, without ODD <ul style="list-style-type: none"> <li>• MT 0266: all models</li> <li>• MT 0384: all models</li> <li>• MT 4168: all models</li> <li>• MT 5067: all models</li> <li>• MT 7516: all models</li> <li>• MT 7519: all models</li> </ul>	45K6212	2
FRU, ODD bezel assembly, with ODD <ul style="list-style-type: none"> <li>• MT 0266: all models</li> <li>• MT 0384: all models</li> <li>• MT 4168: all models</li> <li>• MT 5067: all models</li> <li>• MT 7516: all models</li> <li>• MT 7519: all models</li> </ul>	45K6211	2
FRU, vertical stand <ul style="list-style-type: none"> <li>• MT 0266: all models</li> <li>• MT 0384: all models</li> <li>• MT 4168: all models</li> <li>• MT 5067: all models</li> <li>• MT 7516: all models</li> <li>• MT 7519: all models</li> </ul>	43N9828	1
FRU, SATA cable - optical 370mm <ul style="list-style-type: none"> <li>• MT 0266: all models</li> <li>• MT 0384: all models</li> <li>• MT 4168: all models</li> <li>• MT 5067: all models</li> <li>• MT 7516: all models</li> <li>• MT 7519: all models</li> </ul>	43N9134	2

Mechanical FRUs	FRU #	CRU
FRU, card reader cover bracket, assembly <ul style="list-style-type: none"> <li>• MT 0266: all models</li> <li>• MT 0384: all models</li> <li>• MT 4168: all models</li> <li>• MT 5067: all models</li> <li>• MT 7516: all models</li> <li>• MT 7519: all models</li> </ul>	45K6213	1
FRU, blank cover without media card reader <ul style="list-style-type: none"> <li>• MT 0266: all models</li> <li>• MT 0384: all models</li> <li>• MT 4168: all models</li> <li>• MT 5067: all models</li> <li>• MT 7516: all models</li> <li>• MT 7519: all models</li> </ul>	45K6214	1
FRU, 504BT optical bezel assembly <ul style="list-style-type: none"> <li>• MT 0266: all models</li> <li>• MT 0384: all models</li> <li>• MT 4168: all models</li> <li>• MT 5067: all models</li> <li>• MT 7516: all models</li> <li>• MT 7519: all models</li> </ul>	45K6210	1
FRU, 3.5 HDD to 2.5" 10K RPM HDD conversion kit, no bezel <ul style="list-style-type: none"> <li>• MT 0266: all models</li> <li>• MT 0384: all models</li> <li>• MT 4168: all models</li> <li>• MT 5067: all models</li> <li>• MT 7516: all models</li> <li>• MT 7519: all models</li> </ul>	43N9593	1
FRU, mechanical kit <ul style="list-style-type: none"> <li>• MT 0266: all models</li> <li>• MT 0384: all models</li> <li>• MT 4168: all models</li> <li>• MT 5067: all models</li> <li>• MT 7516: all models</li> <li>• MT 7519: all models</li> </ul>	43N9852	2

Mechanical FRUs	FRU #	CRU
FRU, universal adapter bracket 5.25 to 3.5 <ul style="list-style-type: none"> <li>• MT 0266: all models</li> <li>• MT 0384: all models</li> <li>• MT 4168: all models</li> <li>• MT 5067: all models</li> <li>• MT 7516: all models</li> <li>• MT 7519: all models</li> </ul>	45K6209	2
FRU, access cover assembly <ul style="list-style-type: none"> <li>• MT 0266: all models</li> <li>• MT 0384: all models</li> <li>• MT 4168: all models</li> <li>• MT 5067: all models</li> <li>• MT 7516: all models</li> <li>• MT 7519: all models</li> </ul>	45K6215	2
FRU, base cover assembly <ul style="list-style-type: none"> <li>• MT 0266: all models</li> <li>• MT 0384: all models</li> <li>• MT 4168: all models</li> <li>• MT 5067: all models</li> <li>• MT 7516: all models</li> <li>• MT 7519: all models</li> </ul>	45K6216	2
FRU, HDD tray assembly <ul style="list-style-type: none"> <li>• MT 0266: all models</li> <li>• MT 0384: all models</li> <li>• MT 4168: all models</li> <li>• MT 5067: all models</li> <li>• MT 7516: all models</li> <li>• MT 7519: all models</li> </ul>	45K6218	2
FRU, I/O shielding assembly <ul style="list-style-type: none"> <li>• MT 0266: all models</li> <li>• MT 0384: all models</li> <li>• MT 4168: all models</li> <li>• MT 5067: all models</li> <li>• MT 7516: all models</li> <li>• MT 7519: all models</li> </ul>	45K6219	2

<b>Mechanical FRUs</b>	<b>FRU #</b>	<b>CRU</b>
FRU, system board tray assembly <ul style="list-style-type: none"> <li>• MT 0266: all models</li> <li>• MT 0384: all models</li> <li>• MT 4168: all models</li> <li>• MT 5067: all models</li> <li>• MT 7516: all models</li> <li>• MT 7519: all models</li> </ul>	45K6220	2
FRU, C2 switch assembly <ul style="list-style-type: none"> <li>• MT 0266: all models</li> <li>• MT 0384: all models</li> <li>• MT 4168: all models</li> <li>• MT 5067: all models</li> <li>• MT 7516: all models</li> <li>• MT 7519: all models</li> </ul>	45K6415	2
FRU, front I/O cable assembly <ul style="list-style-type: none"> <li>• MT 0266: all models</li> <li>• MT 0384: all models</li> <li>• MT 4168: all models</li> <li>• MT 5067: all models</li> <li>• MT 7516: all models</li> <li>• MT 7519: all models</li> </ul>	03T9610	2

## Keyboard and Mouse

<b>Keyboard - Preferred Pro USB Keyboard</b>	<b>FRU #</b>	<b>CRU</b>
US English <ul style="list-style-type: none"> <li>• MT 0266: B6M B7U B7M B8U B8M A1H A2H A3A A4A C8G C9G B9G C1G A5G A6G A7G A8G A9G B1G B2G B3G D1U D3U</li> <li>• MT 0384: A9G A7G A8G A1G A2G A3G A4G A5G A6G</li> <li>• MT 4168: A1G</li> <li>• MT 5067: A2U A2P A2L A1U A1L A1G A1M A1A A1Q A1H A1R A1E A3U A3L A3G A1M A1A A3Q A3H A3R A3E</li> <li>• MT 7516: B5M B6M A1H A2H A3A A4A B7G A5G A6G A7G A8G A9G B1G B2G B3G C5U</li> <li>• MT 7519: A1A</li> </ul>	41A5289	1
Arabic <ul style="list-style-type: none"> <li>• MT 0266: C8G C9G B9G C1G A5G A6G A7G A8G A9G B1G B2G B3G D2G</li> <li>• MT 0384: A9G A7G A8G A1G A2G A3G A4G A5G A6G</li> <li>• MT 4168: A1G</li> <li>• MT 5067: A1G A3G</li> <li>• MT 7516: B7G A5G A6G A7G A8G A9G B1G B2G B3G</li> <li>• MT 7519: A2G A3G A4G A5G A6G</li> </ul>	41A5290	1

Keyboard - Preferred Pro USB Keyboard	FRU #	CRU
A/F <ul style="list-style-type: none"> <li>• MT 0266:</li> <li>• MT 0384:</li> <li>• MT 4168:</li> <li>• MT 5067:</li> <li>• MT 7516:</li> <li>• MT 7519:</li> </ul>	41A5291	1
B/F <ul style="list-style-type: none"> <li>• MT 0266: C8G C9G B9G C1G A5G A6G A7G A8G A9G B1G B2G B3G D2G</li> <li>• MT 0384: A9G A7G A8G A1G A2G A3G A4G A5G A6G</li> <li>• MT 4168: A1G</li> <li>• MT 5067: A1G A3G</li> <li>• MT 7516: B7G A5G A6G A7G A8G A9G B1G B2G B3G</li> <li>• MT 7519: A2G A3G A4G A5G A6G</li> </ul>	41A5292	1
Belgium English <ul style="list-style-type: none"> <li>• MT 0266: C8G C9G B9G C1G A5G A6G A7G A8G A9G B1G B2G B3G D2G</li> <li>• MT 0384: A9G A7G A8G A1G A2G A3G A4G A5G A6G</li> <li>• MT 4168: A1G</li> <li>• MT 5067: A1G A3G</li> <li>• MT 7516: B7G A5G A6G A7G A8G A9G B1G B2G B3G</li> <li>• MT 7519: A2G A3G A4G A5G A6G</li> </ul>	41A5293	1
Brazilian Portuguese <ul style="list-style-type: none"> <li>• MT 0266:</li> <li>• MT 0384:</li> <li>• MT 4168:</li> <li>• MT 5067: A2P A1P A3P</li> <li>• MT 7516:</li> <li>• MT 7519:</li> </ul>	41A5294	1
Bulgarian <ul style="list-style-type: none"> <li>• MT 0266: C8G C9G B9G C1G A5G A6G A7G A8G A9G B1G B2G B3G D2G</li> <li>• MT 0384: A9G A7G A8G A1G A2G A3G A4G A5G A6G</li> <li>• MT 4168: A1G</li> <li>• MT 5067: A1G A3G</li> <li>• MT 7516: B7G A5G A6G A7G A8G A9G B1G B2G B3G</li> <li>• MT 7519: A2G A3G A4G A5G A6G</li> </ul>	41A5295	1



Keyboard - Preferred Pro USB Keyboard	FRU #	CRU
Chinese/US <ul style="list-style-type: none"> <li>• MT 0266: A1V A2V</li> <li>• MT 0384:</li> <li>• MT 4168:</li> <li>• MT 5067: A1B A1V A3V</li> <li>• MT 7516: A1V A2V</li> <li>• MT 7519: A7V A8V</li> </ul>	41A5296	1
Czech (ABB) <ul style="list-style-type: none"> <li>• MT 0266: C8G C9G B9G C1G A5G A6G A7G A8G A9G B1G B2G B3G D2G</li> <li>• MT 0384: A9G A7G A8G A1G A2G A3G A4G A5G A6G</li> <li>• MT 4168: A1G</li> <li>• MT 5067: A1G A3G</li> <li>• MT 7516: B7G A5G A6G A7G A8G A9G B1G B2G B3G</li> <li>• MT 7519: A2G A3G A4G A5G A6G</li> </ul>	41A5297	1
Danish <ul style="list-style-type: none"> <li>• MT 0266: C8G C9G B9G C1G A5G A6G A7G A8G A9G B1G B2G B3G D2G</li> <li>• MT 0384: A9G A7G A8G A1G A2G A3G A4G A5G A6G</li> <li>• MT 4168: A1G</li> <li>• MT 5067: A1G A3G</li> <li>• MT 7516: B7G A5G A6G A7G A8G A9G B1G B2G B3G</li> <li>• MT 7519: A2G A3G A4G A5G A6G</li> </ul>	41A5298	1
Dutch <ul style="list-style-type: none"> <li>• MT 0266: C8G C9G B9G C1G A5G A6G A7G A8G A9G B1G B2G B3G D2G</li> <li>• MT 0384: A9G A7G A8G A1G A2G A3G A4G A5G A6G</li> <li>• MT 4168: A1G</li> <li>• MT 5067: A1G A3G</li> <li>• MT 7516: B7G A5G A6G A7G A8G A9G B1G B2G B3G</li> <li>• MT 7519: A2G A3G A4G A5G A6G</li> </ul>	41A5299	1
French <ul style="list-style-type: none"> <li>• MT 0266: C8G C9G B9G C1G A5G A6G A7G A8G A9G B1G B2G B3G D2G</li> <li>• MT 0384: A9G A7G A8G A1G A2G A3G A4G A5G A6G</li> <li>• MT 4168: A1G</li> <li>• MT 5067: A1G A3G</li> <li>• MT 7516: B7G A5G A6G A7G A8G A9G B1G B2G B3G</li> <li>• MT 7519: A2G A3G A4G A5G A6G</li> </ul>	41A5300	1

Keyboard - Preferred Pro USB Keyboard	FRU #	CRU
French Canadian <ul style="list-style-type: none"> <li>• MT 0266: B7F B8F D1F D3F</li> <li>• MT 0384:</li> <li>• MT 4168:</li> <li>• MT 5067: A2F A1F A3F</li> <li>• MT 7516: C5F</li> <li>• MT 7519:</li> </ul>	41A5301	1
French Canadian <ul style="list-style-type: none"> <li>• MT 0266: B7F B8F D1F D3F</li> <li>• MT 0384:</li> <li>• MT 4168:</li> <li>• MT 5067: A2F A1F A3F</li> <li>• MT 7516: C5F</li> <li>• MT 7519:</li> </ul>	41A5302	1
German <ul style="list-style-type: none"> <li>• MT 0266: C8G C9G B9G C1G A5G A6G A7G A8G A9G B1G B2G B3G D2G</li> <li>• MT 0384: A9G A7G A8G A1G A2G A3G A4G A5G A6G</li> <li>• MT 4168: A1G</li> <li>• MT 5067: A1G A3G</li> <li>• MT 7516: B7G A5G A6G A7G A8G A9G B1G B2G B3G</li> <li>• MT 7519: A2G A3G A4G A5G A6G</li> </ul>	41A5303	1
Greek <ul style="list-style-type: none"> <li>• MT 0266: C8G C9G B9G C1G A5G A6G A7G A8G A9G B1G B2G B3G D2G</li> <li>• MT 0384: A9G A7G A8G A1G A2G A3G A4G A5G A6G</li> <li>• MT 4168: A1G</li> <li>• MT 5067: A1G A3G</li> <li>• MT 7516: B7G A5G A6G A7G A8G A9G B1G B2G B3G</li> <li>• MT 7519: A2G A3G A4G A5G A6G</li> </ul>	41A5304	1
Greek/US <ul style="list-style-type: none"> <li>• MT 0266: C8G C9G B9G C1G A5G A6G A7G A8G A9G B1G B2G B3G D2G</li> <li>• MT 0384: A9G A7G A8G A1G A2G A3G A4G A5G A6G</li> <li>• MT 4168: A1G</li> <li>• MT 5067: A1G A3G</li> <li>• MT 7516: B7G A5G A6G A7G A8G A9G B1G B2G B3G</li> <li>• MT 7519: A2G A3G A4G A5G A6G</li> </ul>	41A5305	1

Keyboard - Preferred Pro USB Keyboard	FRU #	CRU
Hebrew <ul style="list-style-type: none"> <li>• MT 0266: C8G C9G B9G C1G A5G A6G A7G A8G A9G B1G B2G B3G D2G</li> <li>• MT 0384: A9G A7G A8G A1G A2G A3G A4G A5G A6G</li> <li>• MT 4168: A1G</li> <li>• MT 5067: A1G A3G</li> <li>• MT 7516: B7G A5G A6G A7G A8G A9G B1G B2G B3G</li> <li>• MT 7519: A2G A3G A4G A5G A6G</li> </ul>	41A5306	1
Hungarian <ul style="list-style-type: none"> <li>• MT 0266: C8G C9G B9G C1G A5G A6G A7G A8G A9G B1G B2G B3G D2G</li> <li>• MT 0384: A9G A7G A8G A1G A2G A3G A4G A5G A6G</li> <li>• MT 4168: A1G</li> <li>• MT 5067: A1G A3G</li> <li>• MT 7516: B7G A5G A6G A7G A8G A9G B1G B2G B3G</li> <li>• MT 7519: A2G A3G A4G A5G A6G</li> </ul>	41A5307	1
Iceland <ul style="list-style-type: none"> <li>• MT 0266: C8G C9G B9G C1G A5G A6G A7G A8G A9G B1G B2G B3G D2G</li> <li>• MT 0384: A9G A7G A8G A1G A2G A3G A4G A5G A6G</li> <li>• MT 4168: A1G</li> <li>• MT 5067: A1G A3G</li> <li>• MT 7516: B7G A5G A6G A7G A8G A9G B1G B2G B3G</li> <li>• MT 7519: A2G A3G A4G A5G A6G</li> </ul>	41A5308	1
Italy <ul style="list-style-type: none"> <li>• MT 0266: C8G C9G B9G C1G A5G A6G A7G A8G A9G B1G B2G B3G D2G</li> <li>• MT 0384: A9G A7G A8G A1G A2G A3G A4G A5G A6G</li> <li>• MT 4168: A1G</li> <li>• MT 5067: A1G A3G</li> <li>• MT 7516: B7G A5G A6G A7G A8G A9G B1G B2G B3G</li> <li>• MT 7519: A2G A3G A4G A5G A6G</li> </ul>	41A5309	1
Japanese <ul style="list-style-type: none"> <li>• MT 0266: C4J C5J C6J C7J D4J D5J D6J D7J</li> <li>• MT 0384:</li> <li>• MT 4168:</li> <li>• MT 5067: A1J A3J</li> <li>• MT 7516: B8J B9J C1J C2J C6J C7J</li> <li>• MT 7519:</li> </ul>	41A5310	1

Keyboard - Preferred Pro USB Keyboard	FRU #	CRU
Korean <ul style="list-style-type: none"> <li>• MT 0266:</li> <li>• MT 0384:</li> <li>• MT 4168:</li> <li>• MT 5067: A1K</li> <li>• MT 7516:</li> <li>• MT 7519:</li> </ul>	41A5311	1
LA Spanish <ul style="list-style-type: none"> <li>• MT 0266: B7S B8S B4S B4D B4Y B5S B5D B5Y D1S D3S</li> <li>• MT 0384:</li> <li>• MT 4168:</li> <li>• MT 5067: A2S A2D A2Y A1S A1D A1Y A3S A3D A3Y</li> <li>• MT 7516: B4S B4D B4Y C5S</li> <li>• MT 7519:</li> </ul>	41A5312	1
Norwegian <ul style="list-style-type: none"> <li>• MT 0266: C8G C9G B9G C1G A5G A6G A7G A8G A9G B1G B2G B3G D2G</li> <li>• MT 0384: A9G A7G A8G A1G A2G A3G A4G A5G A6G</li> <li>• MT 4168: A1G</li> <li>• MT 5067: A1G A3G</li> <li>• MT 7516: B7G A5G A6G A7G A8G A9G B1G B2G B3G</li> <li>• MT 7519: A2G A3G A4G A5G A6G</li> </ul>	41A5313	1
Polish <ul style="list-style-type: none"> <li>• MT 0266: C8G C9G B9G C1G A5G A6G A7G A8G A9G B1G B2G B3G D2G</li> <li>• MT 0384: A9G A7G A8G A1G A2G A3G A4G A5G A6G</li> <li>• MT 4168: A1G</li> <li>• MT 5067: A1G A3G</li> <li>• MT 7516: B7G A5G A6G A7G A8G A9G B1G B2G B3G</li> <li>• MT 7519: A2G A3G A4G A5G A6G</li> </ul>	41A5314	1
Portuguese <ul style="list-style-type: none"> <li>• MT 0266: C8G C9G B9G C1G A5G A6G A7G A8G A9G B1G B2G B3G D2G</li> <li>• MT 0384: A9G A7G A8G A1G A2G A3G A4G A5G A6G</li> <li>• MT 4168: A1G</li> <li>• MT 5067: A1G A3G</li> <li>• MT 7516: B7G A5G A6G A7G A8G A9G B1G B2G B3G</li> <li>• MT 7519: A2G A3G A4G A5G A6G</li> </ul>	41A5315	1

Keyboard - Preferred Pro USB Keyboard	FRU #	CRU
Romanian <ul style="list-style-type: none"> <li>• MT 0266: C8G C9G B9G C1G A5G A6G A7G A8G A9G B1G B2G B3G D2G</li> <li>• MT 0384: A9G A7G A8G A1G A2G A3G A4G A5G A6G</li> <li>• MT 4168: A1G</li> <li>• MT 5067: A1G A3G</li> <li>• MT 7516: B7G A5G A6G A7G A8G A9G B1G B2G B3G</li> <li>• MT 7519: A2G A3G A4G A5G A6G</li> </ul>	41A5317	1
Romanian <ul style="list-style-type: none"> <li>• MT 0266: C8G C9G B9G C1G A5G A6G A7G A8G A9G B1G B2G B3G D2G</li> <li>• MT 0384: A9G A7G A8G A1G A2G A3G A4G A5G A6G</li> <li>• MT 4168: A1G</li> <li>• MT 5067: A1G A3G</li> <li>• MT 7516: B7G A5G A6G A7G A8G A9G B1G B2G B3G</li> <li>• MT 7519: A2G A3G A4G A5G A6G</li> </ul>	41A5316	1
Russian/Cyrillic <ul style="list-style-type: none"> <li>• MT 0266: C8G C9G B9G C1G A5G A6G A7G A8G A9G B1G B2G B3G D2G</li> <li>• MT 0384: A9G A7G A8G A1G A2G A3G A4G A5G A6G</li> <li>• MT 4168: A1G</li> <li>• MT 5067: A1G A3G</li> <li>• MT 7516: B7G A5G A6G A7G A8G A9G B1G B2G B3G</li> <li>• MT 7519: A2G A3G A4G A5G A6G</li> </ul>	41A5318	1
Serbian/Cyrillic <ul style="list-style-type: none"> <li>• MT 0266: C8G C9G B9G C1G A5G A6G A7G A8G A9G B1G B2G B3G D2G</li> <li>• MT 0384: A9G A7G A8G A1G A2G A3G A4G A5G A6G</li> <li>• MT 4168: A1G</li> <li>• MT 5067: A1G A3G</li> <li>• MT 7516: B7G A5G A6G A7G A8G A9G B1G B2G B3G</li> <li>• MT 7519: A2G A3G A4G A5G A6G</li> </ul>	41A5319	1
Slovak <ul style="list-style-type: none"> <li>• MT 0266: C8G C9G B9G C1G A5G A6G A7G A8G A9G B1G B2G B3G D2G</li> <li>• MT 0384: A9G A7G A8G A1G A2G A3G A4G A5G A6G</li> <li>• MT 4168: A1G</li> <li>• MT 5067: A1G A3G</li> <li>• MT 7516: B7G A5G A6G A7G A8G A9G B1G B2G B3G</li> <li>• MT 7519: A2G A3G A4G A5G A6G</li> </ul>	41A5320	1

Keyboard - Preferred Pro USB Keyboard	FRU #	CRU
Spanish <ul style="list-style-type: none"> <li>• MT 0266: C8G C9G B9G C1G A5G A6G A7G A8G A9G B1G B2G B3G D2G</li> <li>• MT 0384: A9G A7G A8G A1G A2G A3G A4G A5G A6G</li> <li>• MT 4168: A1G</li> <li>• MT 5067: A1G A3G</li> <li>• MT 7516: B7G A5G A6G A7G A8G A9G B1G B2G B3G</li> <li>• MT 7519: A2G A3G A4G A5G A6G</li> </ul>	41A5321	1
Swedish/Finnish <ul style="list-style-type: none"> <li>• MT 0266: C8G C9G B9G C1G A5G A6G A7G A8G A9G B1G B2G B3G D2G</li> <li>• MT 0384: A9G A7G A8G A1G A2G A3G A4G A5G A6G</li> <li>• MT 4168: A1G</li> <li>• MT 5067: A1G A3G</li> <li>• MT 7516: B7G A5G A6G A7G A8G A9G B1G B2G B3G</li> <li>• MT 7519: A2G A3G A4G A5G A6G</li> </ul>	41A5322	1
SF/G <ul style="list-style-type: none"> <li>• MT 0266: C8G C9G B9G C1G A5G A6G A7G A8G A9G B1G B2G B3G D2G</li> <li>• MT 0384: A9G A7G A8G A1G A2G A3G A4G A5G A6G</li> <li>• MT 4168: A1G</li> <li>• MT 5067: A1G A3G</li> <li>• MT 7516: B7G A5G A6G A7G A8G A9G B1G B2G B3G</li> <li>• MT 7519: A2G A3G A4G A5G A6G</li> </ul>	41A5323	1
Thailand <ul style="list-style-type: none"> <li>• MT 0266: A3T A4T</li> <li>• MT 0384:</li> <li>• MT 4168:</li> <li>• MT 5067: A1T A3T</li> <li>• MT 7516: A3T A4T</li> <li>• MT 7519: A1T</li> </ul>	41A5324	1
Turkish <ul style="list-style-type: none"> <li>• MT 0266: C8G C9G B9G C1G A5G A6G A7G A8G A9G B1G B2G B3G D2G</li> <li>• MT 0384: A9G A7G A8G A1G A2G A3G A4G A5G A6G</li> <li>• MT 4168: A1G</li> <li>• MT 5067: A1G A3G</li> <li>• MT 7516: B7G A5G A6G A7G A8G A9G B1G B2G B3G</li> <li>• MT 7519: A2G A3G A4G A5G A6G</li> </ul>	41A5325	1

Keyboard - Preferred Pro USB Keyboard	FRU #	CRU
Turkish <ul style="list-style-type: none"> <li>• MT 0266: C8G C9G B9G C1G A5G A6G A7G A8G A9G B1G B2G B3G D2G</li> <li>• MT 0384: A9G A7G A8G A1G A2G A3G A4G A5G A6G</li> <li>• MT 4168: A1G</li> <li>• MT 5067: A1G A3G</li> <li>• MT 7516: B7G A5G A6G A7G A8G A9G B1G B2G B3G</li> <li>• MT 7519: A2G A3G A4G A5G A6G</li> </ul>	41A5326	1
UK English <ul style="list-style-type: none"> <li>• MT 0266: C8G C9G B9G C1G A5G A6G A7G A8G A9G B1G B2G B3G D2G</li> <li>• MT 0384: A9G A7G A8G A1G A2G A3G A4G A5G A6G</li> <li>• MT 4168: A1G</li> <li>• MT 5067: A1G A3G</li> <li>• MT 7516: B7G A5G A6G A7G A8G A9G B1G B2G B3G</li> <li>• MT 7519: A2G A3G A4G A5G A6G</li> </ul>	41A5327	1
US European <ul style="list-style-type: none"> <li>• MT 0266: C8G C9G B9G C1G A5G A6G A7G A8G A9G B1G B2G B3G D2G</li> <li>• MT 0384: A9G A7G A8G A1G A2G A3G A4G A5G A6G</li> <li>• MT 4168: A1G</li> <li>• MT 5067: A1G A3G</li> <li>• MT 7516: B7G A5G A6G A7G A8G A9G B1G B2G B3G</li> <li>• MT 7519: A2G A3G A4G A5G A6G</li> </ul>	41A5328	1
Slovenian <ul style="list-style-type: none"> <li>• MT 0266: C8G C9G B9G C1G A5G A6G A7G A8G A9G B1G B2G B3G D2G</li> <li>• MT 0384: A9G A7G A8G A1G A2G A3G A4G A5G A6G</li> <li>• MT 4168: A1G</li> <li>• MT 5067: A1G A3G</li> <li>• MT 7516: B7G A5G A6G A7G A8G A9G B1G B2G B3G</li> <li>• MT 7519: A2G A3G A4G A5G A6G</li> </ul>	41A5329	1
Arabic (New) <ul style="list-style-type: none"> <li>• MT 0266: C8G C9G B9G C1G A5G A6G A7G A8G A9G B1G B2G B3G D2G</li> <li>• MT 0384: A9G A7G A8G A1G A2G A3G A4G A5G A6G</li> <li>• MT 4168: A1G</li> <li>• MT 5067: A1G A3G</li> <li>• MT 7516: B7G A5G A6G A7G A8G A9G B1G B2G B3G</li> <li>• MT 7519: A2G A3G A4G A5G A6G</li> </ul>	45J4880	1

<b>Keyboard - Preferred Pro USB Keyboard</b>	<b>FRU #</b>	<b>CRU</b>
Lithuanian <ul style="list-style-type: none"> <li>• MT 0266: C8G C9G B9G C1G A5G A6G A7G A8G A9G B1G B2G B3G D2G</li> <li>• MT 0384: A9G A7G A8G A1G A2G A3G A4G A5G A6G</li> <li>• MT 4168: A1G</li> <li>• MT 5067: A1G A3G</li> <li>• MT 7516: B7G A5G A6G A7G A8G A9G B1G B2G B3G</li> <li>• MT 7519: A2G A3G A4G A5G A6G</li> </ul>	45J4896	1
India <ul style="list-style-type: none"> <li>• MT 0266:</li> <li>• MT 0384:</li> <li>• MT 4168:</li> <li>• MT 5067: A2Q A3Q</li> <li>• MT 7516:</li> <li>• MT 7519:</li> </ul>	54Y8381	1

<b>Keyboard - Preferred Pro Full Size PS/2</b>	<b>FRU #</b>	<b>CRU</b>
PS/2--US English <ul style="list-style-type: none"> <li>• MT 0266:</li> <li>• MT 0384:</li> <li>• MT 4168:</li> <li>• MT 5067:</li> <li>• MT 7516:</li> <li>• MT 7519:</li> </ul>	41A5039	1
PS/2--Arabic <ul style="list-style-type: none"> <li>• MT 0266:</li> <li>• MT 0384:</li> <li>• MT 4168:</li> <li>• MT 5067:</li> <li>• MT 7516:</li> <li>• MT 7519:</li> </ul>	41A5040	1
PS/2--A/F <ul style="list-style-type: none"> <li>• MT 0266:</li> <li>• MT 0384:</li> <li>• MT 4168:</li> <li>• MT 5067:</li> <li>• MT 7516:</li> <li>• MT 7519:</li> </ul>	41A5041	1



Keyboard - Preferred Pro Full Size PS/2	FRU #	CRU
PS/2--B/F <ul style="list-style-type: none"> <li>• MT 0266:</li> <li>• MT 0384:</li> <li>• MT 4168:</li> <li>• MT 5067:</li> <li>• MT 7516:</li> <li>• MT 7519:</li> </ul>	41A5042	1
PS/2--Belgium English <ul style="list-style-type: none"> <li>• MT 0266:</li> <li>• MT 0384:</li> <li>• MT 4168:</li> <li>• MT 5067:</li> <li>• MT 7516:</li> <li>• MT 7519:</li> </ul>	41A5043	1
PS/2--Brazilian Portuguese <ul style="list-style-type: none"> <li>• MT 0266:</li> <li>• MT 0384:</li> <li>• MT 4168:</li> <li>• MT 5067:</li> <li>• MT 7516:</li> <li>• MT 7519:</li> </ul>	41A5044	1
PS/2--Bulgarian <ul style="list-style-type: none"> <li>• MT 0266:</li> <li>• MT 0384:</li> <li>• MT 4168:</li> <li>• MT 5067:</li> <li>• MT 7516:</li> <li>• MT 7519:</li> </ul>	41A5045	1
PS/2--Chinese/US <ul style="list-style-type: none"> <li>• MT 0266:</li> <li>• MT 0384:</li> <li>• MT 4168:</li> <li>• MT 5067:</li> <li>• MT 7516:</li> <li>• MT 7519:</li> </ul>	41A5046	1

Keyboard - Preferred Pro Full Size PS/2	FRU #	CRU
PS/2--Czech (ABB) <ul style="list-style-type: none"> <li>• MT 0266:</li> <li>• MT 0384:</li> <li>• MT 4168:</li> <li>• MT 5067:</li> <li>• MT 7516:</li> <li>• MT 7519:</li> </ul>	41A5047	1
PS/2--Danish <ul style="list-style-type: none"> <li>• MT 0266:</li> <li>• MT 0384:</li> <li>• MT 4168:</li> <li>• MT 5067:</li> <li>• MT 7516:</li> <li>• MT 7519:</li> </ul>	41A5048	1
PS/2--Dutch <ul style="list-style-type: none"> <li>• MT 0266:</li> <li>• MT 0384:</li> <li>• MT 4168:</li> <li>• MT 5067:</li> <li>• MT 7516:</li> <li>• MT 7519:</li> </ul>	41A5049	1
PS/2--French <ul style="list-style-type: none"> <li>• MT 0266:</li> <li>• MT 0384:</li> <li>• MT 4168:</li> <li>• MT 5067:</li> <li>• MT 7516:</li> <li>• MT 7519:</li> </ul>	41A5050	1
PS/2--French Canadian <ul style="list-style-type: none"> <li>• MT 0266:</li> <li>• MT 0384:</li> <li>• MT 4168:</li> <li>• MT 5067:</li> <li>• MT 7516:</li> <li>• MT 7519:</li> </ul>	41A5051	1

Keyboard - Preferred Pro Full Size PS/2	FRU #	CRU
PS/2--French Canadian <ul style="list-style-type: none"> <li>• MT 0266:</li> <li>• MT 0384:</li> <li>• MT 4168:</li> <li>• MT 5067:</li> <li>• MT 7516:</li> <li>• MT 7519:</li> </ul>	41A5052	1
PS/2--German <ul style="list-style-type: none"> <li>• MT 0266:</li> <li>• MT 0384:</li> <li>• MT 4168:</li> <li>• MT 5067:</li> <li>• MT 7516:</li> <li>• MT 7519:</li> </ul>	41A5053	1
PS/2--Greek <ul style="list-style-type: none"> <li>• MT 0266:</li> <li>• MT 0384:</li> <li>• MT 4168:</li> <li>• MT 5067:</li> <li>• MT 7516:</li> <li>• MT 7519:</li> </ul>	41A5054	1
PS/2--Greek/US <ul style="list-style-type: none"> <li>• MT 0266:</li> <li>• MT 0384:</li> <li>• MT 4168:</li> <li>• MT 5067:</li> <li>• MT 7516:</li> <li>• MT 7519:</li> </ul>	41A5080	1
PS/2--Hebrew <ul style="list-style-type: none"> <li>• MT 0266:</li> <li>• MT 0384:</li> <li>• MT 4168:</li> <li>• MT 5067:</li> <li>• MT 7516:</li> <li>• MT 7519:</li> </ul>	41A5055	1

Keyboard - Preferred Pro Full Size PS/2	FRU #	CRU
PS/2--Hungarian <ul style="list-style-type: none"> <li>• MT 0266:</li> <li>• MT 0384:</li> <li>• MT 4168:</li> <li>• MT 5067:</li> <li>• MT 7516:</li> <li>• MT 7519:</li> </ul>	41A5056	1
PS/2--Iceland <ul style="list-style-type: none"> <li>• MT 0266:</li> <li>• MT 0384:</li> <li>• MT 4168:</li> <li>• MT 5067:</li> <li>• MT 7516:</li> <li>• MT 7519:</li> </ul>	41A5057	1
PS/2--Italy <ul style="list-style-type: none"> <li>• MT 0266:</li> <li>• MT 0384:</li> <li>• MT 4168:</li> <li>• MT 5067:</li> <li>• MT 7516:</li> <li>• MT 7519:</li> </ul>	41A5058	1
PS/2--Japanese <ul style="list-style-type: none"> <li>• MT 0266:</li> <li>• MT 0384:</li> <li>• MT 4168:</li> <li>• MT 5067:</li> <li>• MT 7516:</li> <li>• MT 7519:</li> </ul>	41A5059	1
PS/2--Korean <ul style="list-style-type: none"> <li>• MT 0266:</li> <li>• MT 0384:</li> <li>• MT 4168:</li> <li>• MT 5067:</li> <li>• MT 7516:</li> <li>• MT 7519:</li> </ul>	41A5060	1

Keyboard - Preferred Pro Full Size PS/2	FRU #	CRU
PS/2--LA Spanish <ul style="list-style-type: none"> <li>• MT 0266:</li> <li>• MT 0384:</li> <li>• MT 4168:</li> <li>• MT 5067:</li> <li>• MT 7516:</li> <li>• MT 7519:</li> </ul>	41A5061	1
PS/2--Norwegian <ul style="list-style-type: none"> <li>• MT 0266:</li> <li>• MT 0384:</li> <li>• MT 4168:</li> <li>• MT 5067:</li> <li>• MT 7516:</li> <li>• MT 7519:</li> </ul>	41A5062	1
PS/2--Polish <ul style="list-style-type: none"> <li>• MT 0266:</li> <li>• MT 0384:</li> <li>• MT 4168:</li> <li>• MT 5067:</li> <li>• MT 7516:</li> <li>• MT 7519:</li> </ul>	41A5063	1
PS/2--Portuguese <ul style="list-style-type: none"> <li>• MT 0266:</li> <li>• MT 0384:</li> <li>• MT 4168:</li> <li>• MT 5067:</li> <li>• MT 7516:</li> <li>• MT 7519:</li> </ul>	41A5064	1
PS/2--Romanian <ul style="list-style-type: none"> <li>• MT 0266:</li> <li>• MT 0384:</li> <li>• MT 4168:</li> <li>• MT 5067:</li> <li>• MT 7516:</li> <li>• MT 7519:</li> </ul>	41A5065	1

Keyboard - Preferred Pro Full Size PS/2	FRU #	CRU
PS/2--Russian/Cyrillic <ul style="list-style-type: none"> <li>• MT 0266:</li> <li>• MT 0384:</li> <li>• MT 4168:</li> <li>• MT 5067:</li> <li>• MT 7516:</li> <li>• MT 7519:</li> </ul>	41A5066	1
PS/2--Serbian/Cyrillic <ul style="list-style-type: none"> <li>• MT 0266:</li> <li>• MT 0384:</li> <li>• MT 4168:</li> <li>• MT 5067:</li> <li>• MT 7516:</li> <li>• MT 7519:</li> </ul>	41A5067	1
PS/2--Slovak <ul style="list-style-type: none"> <li>• MT 0266:</li> <li>• MT 0384:</li> <li>• MT 4168:</li> <li>• MT 5067:</li> <li>• MT 7516:</li> <li>• MT 7519:</li> </ul>	41A5068	1
PS/2--Spanish <ul style="list-style-type: none"> <li>• MT 0266:</li> <li>• MT 0384:</li> <li>• MT 4168:</li> <li>• MT 5067:</li> <li>• MT 7516:</li> <li>• MT 7519:</li> </ul>	41A5069	1
PS/2--Swedish/Finnish <ul style="list-style-type: none"> <li>• MT 0266:</li> <li>• MT 0384:</li> <li>• MT 4168:</li> <li>• MT 5067:</li> <li>• MT 7516:</li> <li>• MT 7519:</li> </ul>	41A5070	1

Keyboard - Preferred Pro Full Size PS/2	FRU #	CRU
PS/2--SF/G <ul style="list-style-type: none"> <li>• MT 0266:</li> <li>• MT 0384:</li> <li>• MT 4168:</li> <li>• MT 5067:</li> <li>• MT 7516:</li> <li>• MT 7519:</li> </ul>	41A5071	1
PS/2--Thailand <ul style="list-style-type: none"> <li>• MT 0266:</li> <li>• MT 0384:</li> <li>• MT 4168:</li> <li>• MT 5067:</li> <li>• MT 7516:</li> <li>• MT 7519:</li> </ul>	41A5072	1
PS/2--Turkish <ul style="list-style-type: none"> <li>• MT 0266:</li> <li>• MT 0384:</li> <li>• MT 4168:</li> <li>• MT 5067:</li> <li>• MT 7516:</li> <li>• MT 7519:</li> </ul>	41A5073	1
PS/2--Turkish <ul style="list-style-type: none"> <li>• MT 0266:</li> <li>• MT 0384:</li> <li>• MT 4168:</li> <li>• MT 5067:</li> <li>• MT 7516:</li> <li>• MT 7519:</li> </ul>	41A5074	1
PS/2 --UK English <ul style="list-style-type: none"> <li>• MT 0266:</li> <li>• MT 0384:</li> <li>• MT 4168:</li> <li>• MT 5067:</li> <li>• MT 7516:</li> <li>• MT 7519:</li> </ul>	41A5075	1

<b>Keyboard - Preferred Pro Full Size PS/2</b>	<b>FRU #</b>	<b>CRU</b>
PS/2--US European <ul style="list-style-type: none"> <li>• MT 0266:</li> <li>• MT 0384:</li> <li>• MT 4168:</li> <li>• MT 5067:</li> <li>• MT 7516:</li> <li>• MT 7519:</li> </ul>	41A5076	1
PS/2--Slovenian <ul style="list-style-type: none"> <li>• MT 0266:</li> <li>• MT 0384:</li> <li>• MT 4168:</li> <li>• MT 5067:</li> <li>• MT 7516:</li> <li>• MT 7519:</li> </ul>	41A5077	1
PS/2--India <ul style="list-style-type: none"> <li>• MT 0266:</li> <li>• MT 0384:</li> <li>• MT 4168:</li> <li>• MT 5067:</li> <li>• MT 7516:</li> <li>• MT 7519:</li> </ul>	54Y8382	1

<b>Keyboard - Fingerprint</b>	<b>FRU #</b>	<b>CRU</b>
US English <ul style="list-style-type: none"> <li>• MT 0266:</li> <li>• MT 0384:</li> <li>• MT 4168:</li> <li>• MT 5067:</li> <li>• MT 7516:</li> <li>• MT 7519:</li> </ul>	57Y4780	1
Arabic <ul style="list-style-type: none"> <li>• MT 0266:</li> <li>• MT 0384:</li> <li>• MT 4168:</li> <li>• MT 5067:</li> <li>• MT 7516:</li> <li>• MT 7519:</li> </ul>	57Y4781	1



Keyboard - Fingerprint	FRU #	CRU
A/F <ul style="list-style-type: none"> <li>• MT 0266:</li> <li>• MT 0384:</li> <li>• MT 4168:</li> <li>• MT 5067:</li> <li>• MT 7516:</li> <li>• MT 7519:</li> </ul>	57Y4782	1
Belgium French <ul style="list-style-type: none"> <li>• MT 0266:</li> <li>• MT 0384:</li> <li>• MT 4168:</li> <li>• MT 5067:</li> <li>• MT 7516:</li> <li>• MT 7519:</li> </ul>	57Y4783	1
Belgium English <ul style="list-style-type: none"> <li>• MT 0266:</li> <li>• MT 0384:</li> <li>• MT 4168:</li> <li>• MT 5067:</li> <li>• MT 7516:</li> <li>• MT 7519:</li> </ul>	57Y4784	1
Brazilian Portuguese <ul style="list-style-type: none"> <li>• MT 0266:</li> <li>• MT 0384:</li> <li>• MT 4168:</li> <li>• MT 5067:</li> <li>• MT 7516:</li> <li>• MT 7519:</li> </ul>	57Y4785	1
Bulgarian <ul style="list-style-type: none"> <li>• MT 0266:</li> <li>• MT 0384:</li> <li>• MT 4168:</li> <li>• MT 5067:</li> <li>• MT 7516:</li> <li>• MT 7519:</li> </ul>	57Y4786	1

Keyboard - Fingerprint	FRU #	CRU
Chinese/US <ul style="list-style-type: none"> <li>• MT 0266:</li> <li>• MT 0384:</li> <li>• MT 4168:</li> <li>• MT 5067:</li> <li>• MT 7516:</li> <li>• MT 7519:</li> </ul>	57Y4787	1
Czech (ABB) <ul style="list-style-type: none"> <li>• MT 0266:</li> <li>• MT 0384:</li> <li>• MT 4168:</li> <li>• MT 5067:</li> <li>• MT 7516:</li> <li>• MT 7519:</li> </ul>	57Y4788	1
Danish <ul style="list-style-type: none"> <li>• MT 0266:</li> <li>• MT 0384:</li> <li>• MT 4168:</li> <li>• MT 5067:</li> <li>• MT 7516:</li> <li>• MT 7519:</li> </ul>	57Y4789	1
Dutch <ul style="list-style-type: none"> <li>• MT 0266:</li> <li>• MT 0384:</li> <li>• MT 4168:</li> <li>• MT 5067:</li> <li>• MT 7516:</li> <li>• MT 7519:</li> </ul>	57Y4790	1
French <ul style="list-style-type: none"> <li>• MT 0266:</li> <li>• MT 0384:</li> <li>• MT 4168:</li> <li>• MT 5067:</li> <li>• MT 7516:</li> <li>• MT 7519:</li> </ul>	57Y4791	1

Keyboard - Fingerprint	FRU #	CRU
French Canadian <ul style="list-style-type: none"> <li>• MT 0266:</li> <li>• MT 0384:</li> <li>• MT 4168:</li> <li>• MT 5067:</li> <li>• MT 7516:</li> <li>• MT 7519:</li> </ul>	57Y4792	1
French Canadian <ul style="list-style-type: none"> <li>• MT 0266:</li> <li>• MT 0384:</li> <li>• MT 4168:</li> <li>• MT 5067:</li> <li>• MT 7516:</li> <li>• MT 7519:</li> </ul>	57Y4793	1
German <ul style="list-style-type: none"> <li>• MT 0266:</li> <li>• MT 0384:</li> <li>• MT 4168:</li> <li>• MT 5067:</li> <li>• MT 7516:</li> <li>• MT 7519:</li> </ul>	57Y4794	1
Greek <ul style="list-style-type: none"> <li>• MT 0266:</li> <li>• MT 0384:</li> <li>• MT 4168:</li> <li>• MT 5067:</li> <li>• MT 7516:</li> <li>• MT 7519:</li> </ul>	57Y4795	1
Greek/US <ul style="list-style-type: none"> <li>• MT 0266:</li> <li>• MT 0384:</li> <li>• MT 4168:</li> <li>• MT 5067:</li> <li>• MT 7516:</li> <li>• MT 7519:</li> </ul>	57Y4796	1

Keyboard - Fingerprint	FRU #	CRU
Hebrew <ul style="list-style-type: none"> <li>• MT 0266:</li> <li>• MT 0384:</li> <li>• MT 4168:</li> <li>• MT 5067:</li> <li>• MT 7516:</li> <li>• MT 7519:</li> </ul>	57Y4797	1
Hungarian <ul style="list-style-type: none"> <li>• MT 0266:</li> <li>• MT 0384:</li> <li>• MT 4168:</li> <li>• MT 5067:</li> <li>• MT 7516:</li> <li>• MT 7519:</li> </ul>	57Y4798	1
Iceland <ul style="list-style-type: none"> <li>• MT 0266:</li> <li>• MT 0384:</li> <li>• MT 4168:</li> <li>• MT 5067:</li> <li>• MT 7516:</li> <li>• MT 7519:</li> </ul>	57Y4799	1
Italy <ul style="list-style-type: none"> <li>• MT 0266:</li> <li>• MT 0384:</li> <li>• MT 4168:</li> <li>• MT 5067:</li> <li>• MT 7516:</li> <li>• MT 7519:</li> </ul>	57Y4800	1
Japanese <ul style="list-style-type: none"> <li>• MT 0266: C4J C5J C6J C7J D8J</li> <li>• MT 0384:</li> <li>• MT 4168:</li> <li>• MT 5067:</li> <li>• MT 7516: C3J C4J C8J C9J</li> <li>• MT 7519:</li> </ul>	57Y4801	1

Keyboard - Fingerprint	FRU #	CRU
Korean <ul style="list-style-type: none"> <li>• MT 0266:</li> <li>• MT 0384:</li> <li>• MT 4168:</li> <li>• MT 5067:</li> <li>• MT 7516:</li> <li>• MT 7519:</li> </ul>	57Y4802	1
LA Spanish <ul style="list-style-type: none"> <li>• MT 0266:</li> <li>• MT 0384:</li> <li>• MT 4168:</li> <li>• MT 5067:</li> <li>• MT 7516:</li> <li>• MT 7519:</li> </ul>	57Y4803	1
Norwegian <ul style="list-style-type: none"> <li>• MT 0266:</li> <li>• MT 0384:</li> <li>• MT 4168:</li> <li>• MT 5067:</li> <li>• MT 7516:</li> <li>• MT 7519:</li> </ul>	57Y4804	1
Polish <ul style="list-style-type: none"> <li>• MT 0266:</li> <li>• MT 0384:</li> <li>• MT 4168:</li> <li>• MT 5067:</li> <li>• MT 7516:</li> <li>• MT 7519:</li> </ul>	57Y4805	1
Portuguese <ul style="list-style-type: none"> <li>• MT 0266:</li> <li>• MT 0384:</li> <li>• MT 4168:</li> <li>• MT 5067:</li> <li>• MT 7516:</li> <li>• MT 7519:</li> </ul>	57Y4806	1

Keyboard - Fingerprint	FRU #	CRU
Romanian <ul style="list-style-type: none"> <li>• MT 0266:</li> <li>• MT 0384:</li> <li>• MT 4168:</li> <li>• MT 5067:</li> <li>• MT 7516:</li> <li>• MT 7519:</li> </ul>	57Y4807	1
Romanian <ul style="list-style-type: none"> <li>• MT 0266:</li> <li>• MT 0384:</li> <li>• MT 4168:</li> <li>• MT 5067:</li> <li>• MT 7516:</li> <li>• MT 7519:</li> </ul>	57Y4808	1
Russian/Cyrillic <ul style="list-style-type: none"> <li>• MT 0266:</li> <li>• MT 0384:</li> <li>• MT 4168:</li> <li>• MT 5067:</li> <li>• MT 7516:</li> <li>• MT 7519:</li> </ul>	57Y4809	1
Serbian/Cyrillic <ul style="list-style-type: none"> <li>• MT 0266:</li> <li>• MT 0384:</li> <li>• MT 4168:</li> <li>• MT 5067:</li> <li>• MT 7516:</li> <li>• MT 7519:</li> </ul>	57Y4810	1
Slovak <ul style="list-style-type: none"> <li>• MT 0266:</li> <li>• MT 0384:</li> <li>• MT 4168:</li> <li>• MT 5067:</li> <li>• MT 7516:</li> <li>• MT 7519:</li> </ul>	57Y4811	1

Keyboard - Fingerprint	FRU #	CRU
Spanish <ul style="list-style-type: none"> <li>• MT 0266:</li> <li>• MT 0384:</li> <li>• MT 4168:</li> <li>• MT 5067:</li> <li>• MT 7516:</li> <li>• MT 7519:</li> </ul>	57Y4812	1
Swedish/Finnish <ul style="list-style-type: none"> <li>• MT 0266:</li> <li>• MT 0384:</li> <li>• MT 4168:</li> <li>• MT 5067:</li> <li>• MT 7516:</li> <li>• MT 7519:</li> </ul>	57Y4813	1
Swiss French/German <ul style="list-style-type: none"> <li>• MT 0266:</li> <li>• MT 0384:</li> <li>• MT 4168:</li> <li>• MT 5067:</li> <li>• MT 7516:</li> <li>• MT 7519:</li> </ul>	57Y4814	1
Thailand <ul style="list-style-type: none"> <li>• MT 0266:</li> <li>• MT 0384:</li> <li>• MT 4168:</li> <li>• MT 5067:</li> <li>• MT 7516:</li> <li>• MT 7519:</li> </ul>	57Y4815	1
Turkish <ul style="list-style-type: none"> <li>• MT 0266:</li> <li>• MT 0384:</li> <li>• MT 4168:</li> <li>• MT 5067:</li> <li>• MT 7516:</li> <li>• MT 7519:</li> </ul>	57Y4816	1

Keyboard - Fingerprint	FRU #	CRU
Turkish <ul style="list-style-type: none"> <li>• MT 0266:</li> <li>• MT 0384:</li> <li>• MT 4168:</li> <li>• MT 5067:</li> <li>• MT 7516:</li> <li>• MT 7519:</li> </ul>	57Y4817	1
UK English <ul style="list-style-type: none"> <li>• MT 0266:</li> <li>• MT 0384:</li> <li>• MT 4168:</li> <li>• MT 5067:</li> <li>• MT 7516:</li> <li>• MT 7519:</li> </ul>	57Y4818	1
US European <ul style="list-style-type: none"> <li>• MT 0266:</li> <li>• MT 0384:</li> <li>• MT 4168:</li> <li>• MT 5067:</li> <li>• MT 7516:</li> <li>• MT 7519:</li> </ul>	57Y4819	1
Slovenian <ul style="list-style-type: none"> <li>• MT 0266:</li> <li>• MT 0384:</li> <li>• MT 4168:</li> <li>• MT 5067:</li> <li>• MT 7516:</li> <li>• MT 7519:</li> </ul>	57Y4820	1
US English <ul style="list-style-type: none"> <li>• MT 0266:</li> <li>• MT 0384:</li> <li>• MT 4168:</li> <li>• MT 5067:</li> <li>• MT 7516:</li> <li>• MT 7519:</li> </ul>	03X8001	1



Keyboard - Fingerprint	FRU #	CRU
Arabic <ul style="list-style-type: none"> <li>• MT 0266:</li> <li>• MT 0384:</li> <li>• MT 4168:</li> <li>• MT 5067:</li> <li>• MT 7516:</li> <li>• MT 7519:</li> </ul>	03X8002	1
A/F <ul style="list-style-type: none"> <li>• MT 0266:</li> <li>• MT 0384:</li> <li>• MT 4168:</li> <li>• MT 5067:</li> <li>• MT 7516:</li> <li>• MT 7519:</li> </ul>	03X8003	1
Belgium French <ul style="list-style-type: none"> <li>• MT 0266:</li> <li>• MT 0384:</li> <li>• MT 4168:</li> <li>• MT 5067:</li> <li>• MT 7516:</li> <li>• MT 7519:</li> </ul>	03X8004	1
Belgium English <ul style="list-style-type: none"> <li>• MT 0266:</li> <li>• MT 0384:</li> <li>• MT 4168:</li> <li>• MT 5067:</li> <li>• MT 7516:</li> <li>• MT 7519:</li> </ul>	03X8005	1
Brazilian Portuguese <ul style="list-style-type: none"> <li>• MT 0266:</li> <li>• MT 0384:</li> <li>• MT 4168:</li> <li>• MT 5067:</li> <li>• MT 7516:</li> <li>• MT 7519:</li> </ul>	03X8006	1

Keyboard - Fingerprint	FRU #	CRU
Bulgarian <ul style="list-style-type: none"> <li>• MT 0266:</li> <li>• MT 0384:</li> <li>• MT 4168:</li> <li>• MT 5067:</li> <li>• MT 7516:</li> <li>• MT 7519:</li> </ul>	03X8007	1
Chinese/US <ul style="list-style-type: none"> <li>• MT 0266:</li> <li>• MT 0384:</li> <li>• MT 4168:</li> <li>• MT 5067:</li> <li>• MT 7516:</li> <li>• MT 7519:</li> </ul>	03X8008	1
Czech (ABB) <ul style="list-style-type: none"> <li>• MT 0266:</li> <li>• MT 0384:</li> <li>• MT 4168:</li> <li>• MT 5067:</li> <li>• MT 7516:</li> <li>• MT 7519:</li> </ul>	03X8009	1
Danish <ul style="list-style-type: none"> <li>• MT 0266:</li> <li>• MT 0384:</li> <li>• MT 4168:</li> <li>• MT 5067:</li> <li>• MT 7516:</li> <li>• MT 7519:</li> </ul>	03X8010	1
Dutch <ul style="list-style-type: none"> <li>• MT 0266:</li> <li>• MT 0384:</li> <li>• MT 4168:</li> <li>• MT 5067:</li> <li>• MT 7516:</li> <li>• MT 7519:</li> </ul>	03X8011	1

Keyboard - Fingerprint	FRU #	CRU
French <ul style="list-style-type: none"> <li>• MT 0266:</li> <li>• MT 0384:</li> <li>• MT 4168:</li> <li>• MT 5067:</li> <li>• MT 7516:</li> <li>• MT 7519:</li> </ul>	03X8012	1
French Canadian <ul style="list-style-type: none"> <li>• MT 0266:</li> <li>• MT 0384:</li> <li>• MT 4168:</li> <li>• MT 5067:</li> <li>• MT 7516:</li> <li>• MT 7519:</li> </ul>	03X8013	1
French Canadian <ul style="list-style-type: none"> <li>• MT 0266:</li> <li>• MT 0384:</li> <li>• MT 4168:</li> <li>• MT 5067:</li> <li>• MT 7516:</li> <li>• MT 7519:</li> </ul>	03X8014	1
German <ul style="list-style-type: none"> <li>• MT 0266:</li> <li>• MT 0384:</li> <li>• MT 4168:</li> <li>• MT 5067:</li> <li>• MT 7516:</li> <li>• MT 7519:</li> </ul>	03X8015	1
Greek <ul style="list-style-type: none"> <li>• MT 0266:</li> <li>• MT 0384:</li> <li>• MT 4168:</li> <li>• MT 5067:</li> <li>• MT 7516:</li> <li>• MT 7519:</li> </ul>	03X8016	1

Keyboard - Fingerprint	FRU #	CRU
Greek/US <ul style="list-style-type: none"> <li>• MT 0266:</li> <li>• MT 0384:</li> <li>• MT 4168:</li> <li>• MT 5067:</li> <li>• MT 7516:</li> <li>• MT 7519:</li> </ul>	03X8017	1
Hebrew <ul style="list-style-type: none"> <li>• MT 0266:</li> <li>• MT 0384:</li> <li>• MT 4168:</li> <li>• MT 5067:</li> <li>• MT 7516:</li> <li>• MT 7519:</li> </ul>	03X8018	1
Hungarian <ul style="list-style-type: none"> <li>• MT 0266:</li> <li>• MT 0384:</li> <li>• MT 4168:</li> <li>• MT 5067:</li> <li>• MT 7516:</li> <li>• MT 7519:</li> </ul>	03X8019	1
Iceland <ul style="list-style-type: none"> <li>• MT 0266:</li> <li>• MT 0384:</li> <li>• MT 4168:</li> <li>• MT 5067:</li> <li>• MT 7516:</li> <li>• MT 7519:</li> </ul>	03X8020	1
Italy <ul style="list-style-type: none"> <li>• MT 0266:</li> <li>• MT 0384:</li> <li>• MT 4168:</li> <li>• MT 5067:</li> <li>• MT 7516:</li> <li>• MT 7519:</li> </ul>	03X8021	1

Keyboard - Fingerprint	FRU #	CRU
Japanese <ul style="list-style-type: none"> <li>• MT 0266: C4J C5J C6J C7J D8J</li> <li>• MT 0384:</li> <li>• MT 4168:</li> <li>• MT 5067:</li> <li>• MT 7516: C3J C4J C8J C9J</li> <li>• MT 7519:</li> </ul>	03X8022	1
Korean <ul style="list-style-type: none"> <li>• MT 0266:</li> <li>• MT 0384:</li> <li>• MT 4168:</li> <li>• MT 5067:</li> <li>• MT 7516:</li> <li>• MT 7519:</li> </ul>	03X8023	1
LA Spanish <ul style="list-style-type: none"> <li>• MT 0266:</li> <li>• MT 0384:</li> <li>• MT 4168:</li> <li>• MT 5067:</li> <li>• MT 7516:</li> <li>• MT 7519:</li> </ul>	03X8024	1
Norwegian <ul style="list-style-type: none"> <li>• MT 0266:</li> <li>• MT 0384:</li> <li>• MT 4168:</li> <li>• MT 5067:</li> <li>• MT 7516:</li> <li>• MT 7519:</li> </ul>	03X8025	1
Polish <ul style="list-style-type: none"> <li>• MT 0266:</li> <li>• MT 0384:</li> <li>• MT 4168:</li> <li>• MT 5067:</li> <li>• MT 7516:</li> <li>• MT 7519:</li> </ul>	03X8026	1

Keyboard - Fingerprint	FRU #	CRU
Portuguese <ul style="list-style-type: none"> <li>• MT 0266:</li> <li>• MT 0384:</li> <li>• MT 4168:</li> <li>• MT 5067:</li> <li>• MT 7516:</li> <li>• MT 7519:</li> </ul>	03X8027	1
Romanian <ul style="list-style-type: none"> <li>• MT 0266:</li> <li>• MT 0384:</li> <li>• MT 4168:</li> <li>• MT 5067:</li> <li>• MT 7516:</li> <li>• MT 7519:</li> </ul>	03X8038	1
Romanian <ul style="list-style-type: none"> <li>• MT 0266:</li> <li>• MT 0384:</li> <li>• MT 4168:</li> <li>• MT 5067:</li> <li>• MT 7516:</li> <li>• MT 7519:</li> </ul>	03X8039	1
Russian/Cyrillic <ul style="list-style-type: none"> <li>• MT 0266:</li> <li>• MT 0384:</li> <li>• MT 4168:</li> <li>• MT 5067:</li> <li>• MT 7516:</li> <li>• MT 7519:</li> </ul>	03X8028	1
Serbian/Cyrillic <ul style="list-style-type: none"> <li>• MT 0266:</li> <li>• MT 0384:</li> <li>• MT 4168:</li> <li>• MT 5067:</li> <li>• MT 7516:</li> <li>• MT 7519:</li> </ul>	03X8040	1

Keyboard - Fingerprint	FRU #	CRU
Slovak <ul style="list-style-type: none"> <li>• MT 0266:</li> <li>• MT 0384:</li> <li>• MT 4168:</li> <li>• MT 5067:</li> <li>• MT 7516:</li> <li>• MT 7519:</li> </ul>	03X8029	1
Spanish <ul style="list-style-type: none"> <li>• MT 0266:</li> <li>• MT 0384:</li> <li>• MT 4168:</li> <li>• MT 5067:</li> <li>• MT 7516:</li> <li>• MT 7519:</li> </ul>	03X8030	1
Swedish/Finnish <ul style="list-style-type: none"> <li>• MT 0266:</li> <li>• MT 0384:</li> <li>• MT 4168:</li> <li>• MT 5067:</li> <li>• MT 7516:</li> <li>• MT 7519:</li> </ul>	03X8031	1
Swiss French/German <ul style="list-style-type: none"> <li>• MT 0266:</li> <li>• MT 0384:</li> <li>• MT 4168:</li> <li>• MT 5067:</li> <li>• MT 7516:</li> <li>• MT 7519:</li> </ul>	03X8032	1
Thailand <ul style="list-style-type: none"> <li>• MT 0266:</li> <li>• MT 0384:</li> <li>• MT 4168:</li> <li>• MT 5067:</li> <li>• MT 7516:</li> <li>• MT 7519:</li> </ul>	03X8033	1

Keyboard - Fingerprint	FRU #	CRU
Turkish <ul style="list-style-type: none"> <li>• MT 0266:</li> <li>• MT 0384:</li> <li>• MT 4168:</li> <li>• MT 5067:</li> <li>• MT 7516:</li> <li>• MT 7519:</li> </ul>	03X8041	1
Turkish <ul style="list-style-type: none"> <li>• MT 0266:</li> <li>• MT 0384:</li> <li>• MT 4168:</li> <li>• MT 5067:</li> <li>• MT 7516:</li> <li>• MT 7519:</li> </ul>	03X8034	1
UK English <ul style="list-style-type: none"> <li>• MT 0266:</li> <li>• MT 0384:</li> <li>• MT 4168:</li> <li>• MT 5067:</li> <li>• MT 7516:</li> <li>• MT 7519:</li> </ul>	03X8035	1
US European <ul style="list-style-type: none"> <li>• MT 0266:</li> <li>• MT 0384:</li> <li>• MT 4168:</li> <li>• MT 5067:</li> <li>• MT 7516:</li> <li>• MT 7519:</li> </ul>	03X8036	1
Slovenian <ul style="list-style-type: none"> <li>• MT 0266:</li> <li>• MT 0384:</li> <li>• MT 4168:</li> <li>• MT 5067:</li> <li>• MT 7516:</li> <li>• MT 7519:</li> </ul>	03X8037	1



Mice	FRU #	CRU
Lenovo enhanced optical USB mouse <ul style="list-style-type: none"> <li>• MT 0266:</li> <li>• MT 0384:</li> <li>• MT 4168:</li> <li>• MT 5067:</li> <li>• MT 7516:</li> <li>• MT 7519:</li> </ul>	45J4889	1
Optical wheel mouse PS/2 <ul style="list-style-type: none"> <li>• MT 0266: B6M B7U B7F B7S B7M B8U B8F B8S B8M A1H A1V A2H A2V A3A A3T A4A A4T B4S B4D B4Y B5S B5D B5Y C8G C9G C2J C3J C4J C5J C6J C7J B9G C1G A5G A6G A7G A8G A9G B1G B2G B3G D1U D1F D1S D2G D3U D3F D3S D4J D5J D6J D7J D8J</li> <li>• MT 0384: A9G A7G A8G A1G A2G A3G A4G A5G A6G</li> <li>• MT 4168: A1G</li> <li>• MT 5067: A2U A2F A2S A2P A2L A2D A2Y A1U A1F A1S A1P A1L A1D A1Y A1G A1M A1A A1Q A1T A1C A1B A1H A1V A1K A1R A1E A1J A3V A3U A3F A3S A3P A3L A3D A3Y A3G A3M A3A A3Q A3T A3C A3B A3H A3R A3E A3J</li> <li>• MT 7516: B5M B6M A1H A1V A2H A2V A3A A3T A4A A4T B4S B4D B4Y B8J B9J C1J C2J B7G A5G A6G A7G A8G A9G B1G B2G B3G C5U C5F C5S C3J C4J C6J C7J C8J C9J</li> <li>• MT 7519: A1A A1T A2G A3G A4G A5G A6G A7V A8V</li> </ul>	51J0061	1

## Adapters and miscellaneous FRUs

Adapters and miscellaneous FRUs	FRU #	CRU
Soft modem V.90/V.44 - LP <ul style="list-style-type: none"> <li>• MT 0266:</li> <li>• MT 0384:</li> <li>• MT 4168:</li> <li>• MT 5067:</li> <li>• MT 7516:</li> <li>• MT 7519:</li> </ul>	03T9027	1
Modem phone cable <ul style="list-style-type: none"> <li>• MT 0266:</li> <li>• MT 0384:</li> <li>• MT 4168:</li> <li>• MT 5067:</li> <li>• MT 7516:</li> <li>• MT 7519:</li> </ul>	39K5120	1

Adapters and miscellaneous FRUs	FRU #	CRU
Lenovo branded speakers <ul style="list-style-type: none"> <li>• MT 0266:</li> <li>• MT 0384:</li> <li>• MT 4168:</li> <li>• MT 5067:</li> <li>• MT 7516:</li> <li>• MT 7519:</li> </ul>	41A5334	1
Speaker power brick <ul style="list-style-type: none"> <li>• MT 0266:</li> <li>• MT 0384:</li> <li>• MT 4168:</li> <li>• MT 5067:</li> <li>• MT 7516:</li> <li>• MT 7519:</li> </ul>	89P8571	1
Thermal grease syringe <ul style="list-style-type: none"> <li>• MT 0266:</li> <li>• MT 0384:</li> <li>• MT 4168:</li> <li>• MT 5067:</li> <li>• MT 7516:</li> <li>• MT 7519:</li> </ul>	91P8835	N
Sunix PCI to parallel port card - (chip update) (LP)® <ul style="list-style-type: none"> <li>• MT 0266:</li> <li>• MT 0384:</li> <li>• MT 4168:</li> <li>• MT 5067:</li> <li>• MT 7516:</li> <li>• MT 7519:</li> </ul>	46R1519	1
Parallel to parallel dongle cable_210mm_R <ul style="list-style-type: none"> <li>• MT 0266:</li> <li>• MT 0384:</li> <li>• MT 4168:</li> <li>• MT 5067:</li> <li>• MT 7516:</li> <li>• MT 7519:</li> </ul>	45J9520	1

## Power Cords

Power Cords	FRU #	CRU
Line Cord - US <ul style="list-style-type: none"> <li>• MT 0266: B7U B7F B7S B8U B8F B8S A3A A3T A4A A4T B4S B4D B5S B5D D1U D1F D1S D3U D3F D3S</li> <li>• MT 0384:</li> <li>• MT 4168:</li> <li>• MT 5067: A2U A2F A2S A2L A2D A1U A1F A1S A1L A1D A1A A1T A3U A3F A3S A3L A3D A3A A3T</li> <li>• MT 7516: A3A A3T A4A A4T B4S B4D C5U C5F C5S</li> <li>• MT 7519: A1A A1T</li> </ul>	41R3184	1
Line Cord - ANZ <ul style="list-style-type: none"> <li>• MT 0266: B6M B7M B8M</li> <li>• MT 0384:</li> <li>• MT 4168:</li> <li>• MT 5067: A1M A3M</li> <li>• MT 7516: B5M B6M</li> <li>• MT 7519:</li> </ul>	41R3196	1
Line Cord - Brazil (Portuguese) <ul style="list-style-type: none"> <li>• MT 0266:</li> <li>• MT 0384:</li> <li>• MT 4168:</li> <li>• MT 5067: A2P A1P A3P</li> <li>• MT 7516:</li> <li>• MT 7519:</li> </ul>	45J9595	1
Line Cord - LA High Volt (APU) <ul style="list-style-type: none"> <li>• MT 0266: B4Y B5Y</li> <li>• MT 0384:</li> <li>• MT 4168:</li> <li>• MT 5067: A2Y A1Y A3Y</li> <li>• MT 7516: B4Y</li> <li>• MT 7519:</li> </ul>	41R3176	1
Line Cord - Korea <ul style="list-style-type: none"> <li>• MT 0266:</li> <li>• MT 0384:</li> <li>• MT 4168:</li> <li>• MT 5067: A1K A1R A3R</li> <li>• MT 7516:</li> <li>• MT 7519:</li> </ul>	41R3260	1

Power Cords	FRU #	CRU
Line Cord - Singapore, Malaysia, Brunei, Hong Kong <ul style="list-style-type: none"> <li>• MT 0266: A1H A2H A3A A4A C8G C9G B9G C1G A5G A6G A7G A8G A9G B1G B2G B3G D2G</li> <li>• MT 0384: A9G A7G A8G A1G A2G A3G A4G A5G A6G</li> <li>• MT 4168: A1G</li> <li>• MT 5067: A1G A1A A1B A1H A3G A3A A3B A3H</li> <li>• MT 7516: A1H A2H A3A A4A B7G A5G A6G A7G A8G A9G B1G B2G B3G</li> <li>• MT 7519: A1A A2G A3G A4G A5G A6G</li> </ul>	41R3224	1
Line Cord - Taiwan <ul style="list-style-type: none"> <li>• MT 0266: A1V A2V</li> <li>• MT 0384:</li> <li>• MT 4168:</li> <li>• MT 5067: A1V A3V</li> <li>• MT 7516: A1V A2V</li> <li>• MT 7519: A7V A8V</li> </ul>	41R3278	1
Line Cord - South Africa <ul style="list-style-type: none"> <li>• MT 0266: B6M B7M B8M A3A A4A C8G C9G B9G C1G A5G A6G A7G A8G A9G B1G B2G B3G D2G</li> <li>• MT 0384: A9G A7G A8G A1G A2G A3G A4G A5G A6G</li> <li>• MT 4168: A1G</li> <li>• MT 5067: A1G A1M A1A A3G A3M A3A</li> <li>• MT 7516: B5M B6M A3A A4A B7G A5G A6G A7G A8G A9G B1G B2G B3G</li> <li>• MT 7519: A1A A2G A3G A4G A5G A6G</li> </ul>	41R3220	1
Line Cord - India <ul style="list-style-type: none"> <li>• MT 0266:</li> <li>• MT 0384:</li> <li>• MT 4168:</li> <li>• MT 5067: A1Q A3Q</li> <li>• MT 7516:</li> <li>• MT 7519:</li> </ul>	41R3341	1
Line Cord - China <ul style="list-style-type: none"> <li>• MT 0266:</li> <li>• MT 0384:</li> <li>• MT 4168:</li> <li>• MT 5067: A1C A3C</li> <li>• MT 7516:</li> <li>• MT 7519:</li> </ul>	41R3256	1

Power Cords	FRU #	CRU
Line Cord - Japan <ul style="list-style-type: none"> <li>• MT 0266: C2J C3J C4J C5J C6J C7J D4J D5J D6J D7J D8J</li> <li>• MT 0384:</li> <li>• MT 4168:</li> <li>• MT 5067: A1J A1E A3J A3E</li> <li>• MT 7516: B8J B9J C1J C2J C3J C4J C6J C7J C8J C9J</li> <li>• MT 7519:</li> </ul>	41R3248	1
Line Cord - Italy <ul style="list-style-type: none"> <li>• MT 0266: B4S B4Y B5S B5Y D1S D3S</li> <li>• MT 0384:</li> <li>• MT 4168:</li> <li>• MT 5067: A2S A2Y A1S A1Y A3S A3Y</li> <li>• MT 7516: B4S B4Y B7G A5G A6G A7G A8G A9G B1G B2G B3G C5S</li> <li>• MT 7519:</li> </ul>	41R3232	1
Line Cord - Indonesia, Laos, Cambodia, and Vietnam <ul style="list-style-type: none"> <li>• MT 0266:</li> <li>• MT 0384:</li> <li>• MT 4168:</li> <li>• MT 5067:</li> <li>• MT 7516:</li> <li>• MT 7519:</li> </ul>	41R3208	1
Line Cord - Denmark <ul style="list-style-type: none"> <li>• MT 0266: C8G C9G B9G C1G A5G A6G A7G A8G A9G B1G B2G B3G D2G</li> <li>• MT 0384: A9G A7G A8G A1G A2G A3G A4G A5G A6G</li> <li>• MT 4168: A1G</li> <li>• MT 5067: A1G A3G</li> <li>• MT 7516: B7G A5G A6G A7G A8G A9G B1G B2G B3G</li> <li>• MT 7519: A2G A3G A4G A5G A6G</li> </ul>	41R3212	1
Line Cord - Switzerland <ul style="list-style-type: none"> <li>• MT 0266: C8G C9G B9G C1G A5G A6G A7G A8G A9G B1G B2G B3G D2G</li> <li>• MT 0384: A9G A7G A8G A1G A2G A3G A4G A5G A6G</li> <li>• MT 4168: A1G</li> <li>• MT 5067: A1G A3G</li> <li>• MT 7516: B7G A5G A6G A7G A8G A9G B1G B2G B3G</li> <li>• MT 7519: A2G A3G A4G A5G A6G</li> </ul>	41R3228	1

Power Cords	FRU #	CRU
Line Cord - Israel <ul style="list-style-type: none"> <li>• MT 0266: C8G C9G B9G C1G A5G A6G A7G A8G A9G B1G B2G B3G D2G</li> <li>• MT 0384: A9G A7G A8G A1G A2G A3G A4G A5G A6G</li> <li>• MT 4168: A1G</li> <li>• MT 5067: A1G A3G</li> <li>• MT 7516: B7G A5G A6G A7G A8G A9G B1G B2G B3G</li> <li>• MT 7519: A2G A3G A4G A5G A6G</li> </ul>	41R3236	1
Line Cord - A models <ul style="list-style-type: none"> <li>• MT 0266: A3A A4A</li> <li>• MT 0384:</li> <li>• MT 4168:</li> <li>• MT 5067: A1A A3A</li> <li>• MT 7516: A3A A4A</li> <li>• MT 7519: A1A</li> </ul>	41R3208	1
Line Cord - Thailand <ul style="list-style-type: none"> <li>• MT 0266:</li> <li>• MT 0384:</li> <li>• MT 4168:</li> <li>• MT 5067: A1T A3T</li> <li>• MT 7516:</li> <li>• MT 7519:</li> </ul>	43N9029	1
Line Cord - UK, Ireland <ul style="list-style-type: none"> <li>• MT 0266:</li> <li>• MT 0384:</li> <li>• MT 4168:</li> <li>• MT 5067: A1G A1A A3G A3A</li> <li>• MT 7516:</li> <li>• MT 7519:</li> </ul>	41R3224	1
Line Cord - US <ul style="list-style-type: none"> <li>• MT 0266: B7U B7F B7S B8U B8F B8S A3A A3T A4A A4T B4S B4D B5S B5D D1U D1F D1S D3U D3F D3S</li> <li>• MT 0384:</li> <li>• MT 4168:</li> <li>• MT 5067: A2U A2F A2S A2L A2D A1U A1F A1S A1L A1D A1A A1T A3U A3F A3S A3L A3D A3A A3T</li> <li>• MT 7516: A3A A3T A4A A4T B4S B4D C5U C5F C5S</li> <li>• MT 7519: A1A A1T</li> </ul>	41R3185	1

Power Cords	FRU #	CRU
Line Cord - China <ul style="list-style-type: none"> <li>• MT 0266:</li> <li>• MT 0384:</li> <li>• MT 4168:</li> <li>• MT 5067: A1M A3M</li> <li>• MT 7516:</li> <li>• MT 7519:</li> </ul>	41R3257	1
Line Cord - Brazil (Portuguese) <ul style="list-style-type: none"> <li>• MT 0266:</li> <li>• MT 0384:</li> <li>• MT 4168:</li> <li>• MT 5067: A2P A1P A3P</li> <li>• MT 7516:</li> <li>• MT 7519:</li> </ul>	41R3271	1
Line Cord - LA High Volt (APU) <ul style="list-style-type: none"> <li>• MT 0266: B4Y B5Y</li> <li>• MT 0384:</li> <li>• MT 4168:</li> <li>• MT 5067: A2Y A1Y A3Y</li> <li>• MT 7516: B4Y</li> <li>• MT 7519:</li> </ul>	41R3177	1
Line Cord - Korea <ul style="list-style-type: none"> <li>• MT 0266:</li> <li>• MT 0384:</li> <li>• MT 4168:</li> <li>• MT 5067: A1K A1R A3R</li> <li>• MT 7516:</li> <li>• MT 7519:</li> </ul>	41R3261	1
Line Cord - Taiwan <ul style="list-style-type: none"> <li>• MT 0266: A1V A2V</li> <li>• MT 0384:</li> <li>• MT 4168:</li> <li>• MT 5067: A1G A1A A1B A1H A3G A3A A3B A3H</li> <li>• MT 7516: A1V A2V</li> <li>• MT 7519: A7V A8V</li> </ul>	41R3279	1

Power Cords	FRU #	CRU
Line Cord - South Africa <ul style="list-style-type: none"> <li>• MT 0266: B6M B7M B8M A3A A4A C8G C9G B9G C1G A5G A6G A7G A8G A9G B1G B2G B3G D2G</li> <li>• MT 0384: A9G A7G A8G A1G A2G A3G A4G A5G A6G</li> <li>• MT 4168: A1G</li> <li>• MT 5067: A1V A3V</li> <li>• MT 7516: B5M B6M A3A A4A B7G A5G A6G A7G A8G A9G B1G B2G B3G</li> <li>• MT 7519: A1A A2G A3G A4G A5G A6G</li> </ul>	41R3221	1
Line Cord - India <ul style="list-style-type: none"> <li>• MT 0266:</li> <li>• MT 0384:</li> <li>• MT 4168:</li> <li>• MT 5067: A1G A1M A1A A3G A3M A3A</li> <li>• MT 7516:</li> <li>• MT 7519:</li> </ul>	41R3175	1
Line Cord - Japanese and Japanese English <ul style="list-style-type: none"> <li>• MT 0266: C2J C3J C4J C5J C6J C7J D4J D5J D6J D7J D8J</li> <li>• MT 0384:</li> <li>• MT 4168:</li> <li>• MT 5067: A1Q A3Q</li> <li>• MT 7516: B8J B9J C1J C2J C3J C4J C6J C7J C8J C9J</li> <li>• MT 7519:</li> </ul>	41R3249	1
Line Cord - ANZ <ul style="list-style-type: none"> <li>• MT 0266: B6M B7M B8M</li> <li>• MT 0384:</li> <li>• MT 4168:</li> <li>• MT 5067: A1C A3C</li> <li>• MT 7516: B5M B6M</li> <li>• MT 7519:</li> </ul>	41R3197	1
Line Cord - Singapore, Malaysia, Brunei, Hong Kong <ul style="list-style-type: none"> <li>• MT 0266: A1H A2H A3A A4A C8G C9G B9G C1G A5G A6G A7G A8G A9G B1G B2G B3G D2G</li> <li>• MT 0384: A9G A7G A8G A1G A2G A3G A4G A5G A6G</li> <li>• MT 4168: A1G</li> <li>• MT 5067: A1J A1E A3J A3E</li> <li>• MT 7516: A1H A2H A3A A4A B7G A5G A6G A7G A8G A9G B1G B2G B3G</li> <li>• MT 7519: A1A A2G A3G A4G A5G A6G</li> </ul>	41R3225	1



Power Cords	FRU #	CRU
Line Cord - UK Ireland <ul style="list-style-type: none"> <li>• MT 0266:</li> <li>• MT 0384:</li> <li>• MT 4168:</li> <li>• MT 5067: A2S A2Y A1S A1Y A3S A3Y</li> <li>• MT 7516:</li> <li>• MT 7519:</li> </ul>	41R3225	1
Line Cord - Italy <ul style="list-style-type: none"> <li>• MT 0266: B4S B4Y B5S B5Y D1S D3S</li> <li>• MT 0384:</li> <li>• MT 4168:</li> <li>• MT 5067:</li> <li>• MT 7516: B4S B4Y B7G A5G A6G A7G A8G A9G B1G B2G B3G C5S</li> <li>• MT 7519:</li> </ul>	41R3233	1
Line Cord - Indonesia, Laos, Cambodia, and Vietnam A models <ul style="list-style-type: none"> <li>• MT 0266:</li> <li>• MT 0384:</li> <li>• MT 4168:</li> <li>• MT 5067: A1G A3G</li> <li>• MT 7516:</li> <li>• MT 7519:</li> </ul>	41R3209	1
Line Cord - Denmark <ul style="list-style-type: none"> <li>• MT 0266: C8G C9G B9G C1G A5G A6G A7G A8G A9G B1G B2G B3G D2G</li> <li>• MT 0384: A9G A7G A8G A1G A2G A3G A4G A5G A6G</li> <li>• MT 4168: A1G</li> <li>• MT 5067: A1G A3G</li> <li>• MT 7516: B7G A5G A6G A7G A8G A9G B1G B2G B3G</li> <li>• MT 7519: A2G A3G A4G A5G A6G</li> </ul>	41R3213	1
Line Cord - Switzerland <ul style="list-style-type: none"> <li>• MT 0266: C8G C9G B9G C1G A5G A6G A7G A8G A9G B1G B2G B3G D2G</li> <li>• MT 0384: A9G A7G A8G A1G A2G A3G A4G A5G A6G</li> <li>• MT 4168: A1G</li> <li>• MT 5067: A1G A3G</li> <li>• MT 7516: B7G A5G A6G A7G A8G A9G B1G B2G B3G</li> <li>• MT 7519: A2G A3G A4G A5G A6G</li> </ul>	41R3229	1

Power Cords	FRU #	CRU
Line Cord - Israel <ul style="list-style-type: none"> <li>• MT 0266: C8G C9G B9G C1G A5G A6G A7G A8G A9G B1G B2G B3G D2G</li> <li>• MT 0384: A9G A7G A8G A1G A2G A3G A4G A5G A6G</li> <li>• MT 4168: A1G</li> <li>• MT 5067: A1A A3A</li> <li>• MT 7516: B7G A5G A6G A7G A8G A9G B1G B2G B3G</li> <li>• MT 7519: A2G A3G A4G A5G A6G</li> </ul>	41R3237	1
Line Cord - Austria, Belgium, Croatia, Czechoslovakia, Finland, France, Germany, Hungary, Netherlands, Norway, Poland, Portugal, Romania, Spain, Sweden <ul style="list-style-type: none"> <li>• MT 0266: A3A A4A</li> <li>• MT 0384:</li> <li>• MT 4168:</li> <li>• MT 5067: A1T A3T</li> <li>• MT 7516: A3A A4A</li> <li>• MT 7519: A1A</li> </ul>	41R3209	1
Line Cord - Thailand <ul style="list-style-type: none"> <li>• MT 0266:</li> <li>• MT 0384:</li> <li>• MT 4168:</li> <li>• MT 5067: A1G A1A A3G A3A</li> <li>• MT 7516:</li> <li>• MT 7519:</li> </ul>	43N9030	1

## Recovery discs

### Windows 7 Professional 32 Recovery CD

Windows 7 Professional 32	FRU #	CRU
Arabic <ul style="list-style-type: none"> <li>• MT 0266: B9G C1G</li> <li>• MT 0384: A7G A8G</li> <li>• MT 4168:</li> <li>• MT 5067: A1G</li> <li>• MT 7516: B7G</li> <li>• MT 7519: A4G A5G A6G</li> </ul>	03T0856	1
Brazilian Portuguese <ul style="list-style-type: none"> <li>• MT 0266:</li> <li>• MT 0384:</li> <li>• MT 4168:</li> <li>• MT 5067: A1P</li> <li>• MT 7516:</li> <li>• MT 7519:</li> </ul>	03T0857	1

Windows 7 Professional 32	FRU #	CRU
Simplified Chinese <ul style="list-style-type: none"> <li>• MT 0266:</li> <li>• MT 0384:</li> <li>• MT 4168:</li> <li>• MT 5067:</li> <li>• MT 7516:</li> <li>• MT 7519:</li> </ul>	03T0858	1
Chinese-Traditional <ul style="list-style-type: none"> <li>• MT 0266: A1V A2V</li> <li>• MT 0384:</li> <li>• MT 4168:</li> <li>• MT 5067: A1B A1V A3V</li> <li>• MT 7516: A1V A2V</li> <li>• MT 7519: A7V A8V</li> </ul>	03T0859	1
Czech <ul style="list-style-type: none"> <li>• MT 0266: B9G C1G</li> <li>• MT 0384: A7G A8G</li> <li>• MT 4168:</li> <li>• MT 5067: A1G</li> <li>• MT 7516: B7G</li> <li>• MT 7519: A4G A5G A6G</li> </ul>	03T0860	1
India English <ul style="list-style-type: none"> <li>• MT 0266: B9G C1G</li> <li>• MT 0384: A7G A8G</li> <li>• MT 4168:</li> <li>• MT 5067: A1G</li> <li>• MT 7516: B7G</li> <li>• MT 7519: A4G A5G A6G</li> </ul>	03T0861	1
French <ul style="list-style-type: none"> <li>• MT 0266: B9G C1G</li> <li>• MT 0384: A7G A8G</li> <li>• MT 4168:</li> <li>• MT 5067: A1F A1G</li> <li>• MT 7516: B7G</li> <li>• MT 7519: A4G A5G A6G</li> </ul>	03T0862	1

Windows 7 Professional 32	FRU #	CRU
Greek <ul style="list-style-type: none"> <li>• MT 0266: B9G C1G</li> <li>• MT 0384: A7G A8G</li> <li>• MT 4168:</li> <li>• MT 5067: A1G</li> <li>• MT 7516: B7G</li> <li>• MT 7519: A4G A5G A6G</li> </ul>	03T0863	1
German <ul style="list-style-type: none"> <li>• MT 0266: B9G C1G</li> <li>• MT 0384: A7G A8G</li> <li>• MT 4168:</li> <li>• MT 5067: A1G</li> <li>• MT 7516: B7G</li> <li>• MT 7519: A4G A5G A6G</li> </ul>	03T0864	1
Hebrew <ul style="list-style-type: none"> <li>• MT 0266: B9G C1G</li> <li>• MT 0384: A7G A8G</li> <li>• MT 4168:</li> <li>• MT 5067: A1G</li> <li>• MT 7516: B7G</li> <li>• MT 7519: A4G A5G A6G</li> </ul>	03T0865	1
Hong Kong <ul style="list-style-type: none"> <li>• MT 0266:</li> <li>• MT 0384:</li> <li>• MT 4168:</li> <li>• MT 5067: A1G</li> <li>• MT 7516: B7G</li> <li>• MT 7519:</li> </ul>	03T0866	1
Hungarian <ul style="list-style-type: none"> <li>• MT 0266: B9G C1G</li> <li>• MT 0384: A7G A8G</li> <li>• MT 4168:</li> <li>• MT 5067: A1G</li> <li>• MT 7516: B7G</li> <li>• MT 7519: A4G A5G A6G</li> </ul>	03T0867	1

Windows 7 Professional 32	FRU #	CRU
Italian <ul style="list-style-type: none"> <li>• MT 0266: B9G C1G</li> <li>• MT 0384: A7G A8G</li> <li>• MT 4168:</li> <li>• MT 5067: A1G</li> <li>• MT 7516: B7G</li> <li>• MT 7519: A4G A5G A6G</li> </ul>	03T0868	1
Japanese <ul style="list-style-type: none"> <li>• MT 0266: C2J C3J C4J C5J D6J D7J D8J</li> <li>• MT 0384:</li> <li>• MT 4168:</li> <li>• MT 5067: A1J</li> <li>• MT 7516: B8J B9J C1J C2J C3J C4J C6J C7J C8J C9J</li> <li>• MT 7519:</li> </ul>	03T0869	1
Korean <ul style="list-style-type: none"> <li>• MT 0266:</li> <li>• MT 0384:</li> <li>• MT 4168:</li> <li>• MT 5067: A1K</li> <li>• MT 7516:</li> <li>• MT 7519:</li> </ul>	03T0870	1
Polish <ul style="list-style-type: none"> <li>• MT 0266: B9G C1G</li> <li>• MT 0384: A7G A8G</li> <li>• MT 4168:</li> <li>• MT 5067: A1G</li> <li>• MT 7516: B7G</li> <li>• MT 7519: A4G A5G A6G</li> </ul>	03T0871	1
Portuguese <ul style="list-style-type: none"> <li>• MT 0266: B9G C1G</li> <li>• MT 0384: A7G A8G</li> <li>• MT 4168:</li> <li>• MT 5067: A1G</li> <li>• MT 7516: B7G</li> <li>• MT 7519: A4G A5G A6G</li> </ul>	03T0872	1

Windows 7 Professional 32	FRU #	CRU
Romanian <ul style="list-style-type: none"> <li>• MT 0266: B9G C1G</li> <li>• MT 0384: A7G A8G</li> <li>• MT 4168:</li> <li>• MT 5067: A1G</li> <li>• MT 7516: B7G</li> <li>• MT 7519: A4G A5G A6G</li> </ul>	03T0873	1
Russian <ul style="list-style-type: none"> <li>• MT 0266: B9G C1G</li> <li>• MT 0384: A7G A8G</li> <li>• MT 4168:</li> <li>• MT 5067: A1G</li> <li>• MT 7516: B7G</li> <li>• MT 7519: A4G A5G A6G</li> </ul>	03T0874	1
Slovakian <ul style="list-style-type: none"> <li>• MT 0266: B9G C1G</li> <li>• MT 0384: A7G A8G</li> <li>• MT 4168:</li> <li>• MT 5067: A1G</li> <li>• MT 7516: B7G</li> <li>• MT 7519: A4G A5G A6G</li> </ul>	03T0875	1
Spanish <ul style="list-style-type: none"> <li>• MT 0266: B9G C1G</li> <li>• MT 0384: A7G A8G</li> <li>• MT 4168:</li> <li>• MT 5067: A1G</li> <li>• MT 7516: B7G</li> <li>• MT 7519: A4G A5G A6G</li> </ul>	03T0876	1
Sebian- Latin <ul style="list-style-type: none"> <li>• MT 0266: B9G C1G</li> <li>• MT 0384: A7G A8G</li> <li>• MT 4168:</li> <li>• MT 5067: A1G</li> <li>• MT 7516: B7G</li> <li>• MT 7519: A4G A5G A6G</li> </ul>	03T0877	1

Windows 7 Professional 32	FRU #	CRU
Turkish <ul style="list-style-type: none"> <li>• MT 0266: B9G C1G</li> <li>• MT 0384: A7G A8G</li> <li>• MT 4168:</li> <li>• MT 5067: A1G</li> <li>• MT 7516: B7G</li> <li>• MT 7519: A4G A5G A6G</li> </ul>	03T0878	1
English <ul style="list-style-type: none"> <li>• MT 0266: A1H A2H A3A A4A</li> <li>• MT 0384:</li> <li>• MT 4168:</li> <li>• MT 5067: A1U A1L A1M A1A A1Q A1H A1R A1E</li> <li>• MT 7516: A1H A2H A3A A4A</li> <li>• MT 7519: A1A A1T A4G A5G A6G</li> </ul>	03T0879	1
C&L Nordics (DK/FI/SV/NO/EN) <ul style="list-style-type: none"> <li>• MT 0266: B9G C1G</li> <li>• MT 0384: A7G A8G</li> <li>• MT 4168:</li> <li>• MT 5067: A1G</li> <li>• MT 7516: B7G</li> <li>• MT 7519: A4G A5G A6G</li> </ul>	03T0880	1
C&L EMEA (NL/FR/GR/IT/EN) <ul style="list-style-type: none"> <li>• MT 0266: B9G C1G</li> <li>• MT 0384: A7G A8G</li> <li>• MT 4168:</li> <li>• MT 5067: A1G</li> <li>• MT 7516: B7G</li> <li>• MT 7519: A4G A5G A6G</li> </ul>	03T0881	1
C&L Croatian (EN/SL/CR) <ul style="list-style-type: none"> <li>• MT 0266: B9G C1G</li> <li>• MT 0384: A7G A8G</li> <li>• MT 4168:</li> <li>• MT 5067: A1G</li> <li>• MT 7516: B7G</li> <li>• MT 7519: A4G A5G A6G</li> </ul>	03T0882	1

## Windows 7 Home Basic 32 Recovery CD

Windows 7 Home Basic 32	FRU #	CRU
Arabic <ul style="list-style-type: none"> <li>• MT 0266:</li> <li>• MT 0384:</li> <li>• MT 4168:</li> <li>• MT 5067:</li> <li>• MT 7516:</li> <li>• MT 7519:</li> </ul>	03T0883	1
Brazilian Portuguese <ul style="list-style-type: none"> <li>• MT 0266:</li> <li>• MT 0384:</li> <li>• MT 4168:</li> <li>• MT 5067:</li> <li>• MT 7516:</li> <li>• MT 7519:</li> </ul>	03T0884	1
Chinese-simplified <ul style="list-style-type: none"> <li>• MT 0266:</li> <li>• MT 0384:</li> <li>• MT 4168:</li> <li>• MT 5067:</li> <li>• MT 7516:</li> <li>• MT 7519:</li> </ul>	03T0885	1
India English <ul style="list-style-type: none"> <li>• MT 0266:</li> <li>• MT 0384:</li> <li>• MT 4168:</li> <li>• MT 5067:</li> <li>• MT 7516:</li> <li>• MT 7519:</li> </ul>	03T0886	1
Russian <ul style="list-style-type: none"> <li>• MT 0266:</li> <li>• MT 0384:</li> <li>• MT 4168:</li> <li>• MT 5067:</li> <li>• MT 7516:</li> <li>• MT 7519:</li> </ul>	03T0887	1



Windows 7 Home Basic 32	FRU #	CRU
Spanish <ul style="list-style-type: none"> <li>• MT 0266:</li> <li>• MT 0384:</li> <li>• MT 4168:</li> <li>• MT 5067:</li> <li>• MT 7516:</li> <li>• MT 7519:</li> </ul>	03T0888	1
Serbian-Latin <ul style="list-style-type: none"> <li>• MT 0266:</li> <li>• MT 0384:</li> <li>• MT 4168:</li> <li>• MT 5067:</li> <li>• MT 7516:</li> <li>• MT 7519:</li> </ul>	03T0889	1
Turkish <ul style="list-style-type: none"> <li>• MT 0266:</li> <li>• MT 0384:</li> <li>• MT 4168:</li> <li>• MT 5067:</li> <li>• MT 7516:</li> <li>• MT 7519:</li> </ul>	03T0890	1
English <ul style="list-style-type: none"> <li>• MT 0266:</li> <li>• MT 0384:</li> <li>• MT 4168:</li> <li>• MT 5067:</li> <li>• MT 7516:</li> <li>• MT 7519:</li> </ul>	03T0891	1

## Windows 7 Home Premium 64 Recovery CD

Windows 7 Home Premium 64	FRU #	CRU
India English <ul style="list-style-type: none"> <li>• MT 0266:</li> <li>• MT 0384:</li> <li>• MT 4168:</li> <li>• MT 5067:</li> <li>• MT 7516:</li> <li>• MT 7519:</li> </ul>	03T0892	1
English <ul style="list-style-type: none"> <li>• MT 0266:</li> <li>• MT 0384:</li> </ul>	03T0893	1

Windows 7 Home Premium 64	FRU #	CRU
<ul style="list-style-type: none"> <li>• MT 4168:</li> <li>• MT 5067:</li> <li>• MT 7516:</li> <li>• MT 7519:</li> </ul>		

## Windows 7 Home Premium 32 Recovery CD

Windows 7 Home Premium 32	FRU #	CRU
Brazilian Portuguese <ul style="list-style-type: none"> <li>• MT 0266:</li> <li>• MT 0384:</li> <li>• MT 4168:</li> <li>• MT 5067:</li> <li>• MT 7516:</li> <li>• MT 7519:</li> </ul>	03T0919	1
Chinese-Simplified <ul style="list-style-type: none"> <li>• MT 0266:</li> <li>• MT 0384:</li> <li>• MT 4168:</li> <li>• MT 5067:</li> <li>• MT 7516:</li> <li>• MT 7519:</li> </ul>	03T0920	1
Chinese-Traditional <ul style="list-style-type: none"> <li>• MT 0266:</li> <li>• MT 0384:</li> <li>• MT 4168:</li> <li>• MT 5067:</li> <li>• MT 7516:</li> <li>• MT 7519:</li> </ul>	03T0921	1
Czech <ul style="list-style-type: none"> <li>• MT 0266:</li> <li>• MT 0384:</li> <li>• MT 4168:</li> <li>• MT 5067:</li> <li>• MT 7516:</li> <li>• MT 7519:</li> </ul>	03T0922	1

Windows 7 Home Premium 32	FRU #	CRU
India English <ul style="list-style-type: none"> <li>• MT 0266:</li> <li>• MT 0384:</li> <li>• MT 4168:</li> <li>• MT 5067:</li> <li>• MT 7516:</li> <li>• MT 7519:</li> </ul>	03T0923	1
French <ul style="list-style-type: none"> <li>• MT 0266:</li> <li>• MT 0384:</li> <li>• MT 4168:</li> <li>• MT 5067:</li> <li>• MT 7516:</li> <li>• MT 7519:</li> </ul>	03T0924	1
Hong Kong <ul style="list-style-type: none"> <li>• MT 0266:</li> <li>• MT 0384:</li> <li>• MT 4168:</li> <li>• MT 5067:</li> <li>• MT 7516:</li> <li>• MT 7519:</li> </ul>	03T0925	1
Italy <ul style="list-style-type: none"> <li>• MT 0266:</li> <li>• MT 0384:</li> <li>• MT 4168:</li> <li>• MT 5067:</li> <li>• MT 7516:</li> <li>• MT 7519:</li> </ul>	03T0926	1
Japanese <ul style="list-style-type: none"> <li>• MT 0266:</li> <li>• MT 0384:</li> <li>• MT 4168:</li> <li>• MT 5067:</li> <li>• MT 7516:</li> <li>• MT 7519:</li> </ul>	03T0927	1

Windows 7 Home Premium 32	FRU #	CRU
Korean <ul style="list-style-type: none"> <li>• MT 0266:</li> <li>• MT 0384:</li> <li>• MT 4168:</li> <li>• MT 5067:</li> <li>• MT 7516:</li> <li>• MT 7519:</li> </ul>	03T0928	1
Spanish <ul style="list-style-type: none"> <li>• MT 0266:</li> <li>• MT 0384:</li> <li>• MT 4168:</li> <li>• MT 5067:</li> <li>• MT 7516:</li> <li>• MT 7519:</li> </ul>	03T0929	1
US English <ul style="list-style-type: none"> <li>• MT 0266:</li> <li>• MT 0384:</li> <li>• MT 4168:</li> <li>• MT 5067:</li> <li>• MT 7516:</li> <li>• MT 7519:</li> </ul>	03T0930	1
C&L Nordics (DK/FI/SV/NO/EN) <ul style="list-style-type: none"> <li>• MT 0266:</li> <li>• MT 0384:</li> <li>• MT 4168:</li> <li>• MT 5067:</li> <li>• MT 7516:</li> <li>• MT 7519:</li> </ul>	03T0931	1
C&L EMEA (NL/FR/GR/IT/EN) <ul style="list-style-type: none"> <li>• MT 0266:</li> <li>• MT 0384:</li> <li>• MT 4168:</li> <li>• MT 5067:</li> <li>• MT 7516:</li> <li>• MT 7519:</li> </ul>	03T0932	1

## Windows XP Professional 32 Recovery CD

Windows XP Professional 32	FRU #	CRU
Japanese <ul style="list-style-type: none"> <li>• MT 0266:</li> <li>• MT 0384:</li> <li>• MT 4168:</li> <li>• MT 5067:</li> <li>• MT 7516:</li> <li>• MT 7519:</li> </ul>	03T0501	1
English <ul style="list-style-type: none"> <li>• MT 0266:</li> <li>• MT 0384:</li> <li>• MT 4168:</li> <li>• MT 5067:</li> <li>• MT 7516:</li> <li>• MT 7519:</li> </ul>	03T0502	1
Brazil Portuguese <ul style="list-style-type: none"> <li>• MT 0266:</li> <li>• MT 0384:</li> <li>• MT 4168:</li> <li>• MT 5067:</li> <li>• MT 7516:</li> <li>• MT 7519:</li> </ul>	03T0723	1
Traditional Chinese <ul style="list-style-type: none"> <li>• MT 0266:</li> <li>• MT 0384:</li> <li>• MT 4168:</li> <li>• MT 5067:</li> <li>• MT 7516:</li> <li>• MT 7519:</li> </ul>	03T0724	1
Czech <ul style="list-style-type: none"> <li>• MT 0266:</li> <li>• MT 0384:</li> <li>• MT 4168:</li> <li>• MT 5067:</li> <li>• MT 7516:</li> <li>• MT 7519:</li> </ul>	03T0725	1

Windows XP Professional 32	FRU #	CRU
Denmark <ul style="list-style-type: none"> <li>• MT 0266:</li> <li>• MT 0384:</li> <li>• MT 4168:</li> <li>• MT 5067:</li> <li>• MT 7516:</li> <li>• MT 7519:</li> </ul>	03T0726	1
Finnish <ul style="list-style-type: none"> <li>• MT 0266:</li> <li>• MT 0384:</li> <li>• MT 4168:</li> <li>• MT 5067:</li> <li>• MT 7516:</li> <li>• MT 7519:</li> </ul>	03T0727	1
French <ul style="list-style-type: none"> <li>• MT 0266:</li> <li>• MT 0384:</li> <li>• MT 4168:</li> <li>• MT 5067:</li> <li>• MT 7516:</li> <li>• MT 7519:</li> </ul>	03T0737	1
German <ul style="list-style-type: none"> <li>• MT 0266:</li> <li>• MT 0384:</li> <li>• MT 4168:</li> <li>• MT 5067:</li> <li>• MT 7516:</li> <li>• MT 7519:</li> </ul>	03T0728	1
Hong Kong <ul style="list-style-type: none"> <li>• MT 0266:</li> <li>• MT 0384:</li> <li>• MT 4168:</li> <li>• MT 5067:</li> <li>• MT 7516:</li> <li>• MT 7519:</li> </ul>	03T0729	1

Windows XP Professional 32	FRU #	CRU
Italian <ul style="list-style-type: none"> <li>• MT 0266:</li> <li>• MT 0384:</li> <li>• MT 4168:</li> <li>• MT 5067:</li> <li>• MT 7516:</li> <li>• MT 7519:</li> </ul>	03T0730	1
Norwegian <ul style="list-style-type: none"> <li>• MT 0266:</li> <li>• MT 0384:</li> <li>• MT 4168:</li> <li>• MT 5067:</li> <li>• MT 7516:</li> <li>• MT 7519:</li> </ul>	03T0731	1
Polish <ul style="list-style-type: none"> <li>• MT 0266:</li> <li>• MT 0384:</li> <li>• MT 4168:</li> <li>• MT 5067:</li> <li>• MT 7516:</li> <li>• MT 7519:</li> </ul>	03T0732	1
Russian <ul style="list-style-type: none"> <li>• MT 0266:</li> <li>• MT 0384:</li> <li>• MT 4168:</li> <li>• MT 5067:</li> <li>• MT 7516:</li> <li>• MT 7519:</li> </ul>	03T0733	1
Spanish <ul style="list-style-type: none"> <li>• MT 0266:</li> <li>• MT 0384:</li> <li>• MT 4168:</li> <li>• MT 5067:</li> <li>• MT 7516:</li> <li>• MT 7519:</li> </ul>	03T0734	1

Windows XP Professional 32	FRU #	CRU
Swedish <ul style="list-style-type: none"> <li>• MT 0266:</li> <li>• MT 0384:</li> <li>• MT 4168:</li> <li>• MT 5067:</li> <li>• MT 7516:</li> <li>• MT 7519:</li> </ul>	03T0735	1
Turkish <ul style="list-style-type: none"> <li>• MT 0266:</li> <li>• MT 0384:</li> <li>• MT 4168:</li> <li>• MT 5067:</li> <li>• MT 7516:</li> <li>• MT 7519:</li> </ul>	03T0736	1

## Windows 7 Professional 64 Recovery CD

Windows 7 Professional 64	FRU #	CRU
Arabic <ul style="list-style-type: none"> <li>• MT 0266: D2G</li> <li>• MT 0384:</li> <li>• MT 4168:</li> <li>• MT 5067: A3G</li> <li>• MT 7516:</li> <li>• MT 7519: A2G A3G</li> </ul>	03T0894	1
Brazilian Portuguese <ul style="list-style-type: none"> <li>• MT 0266:</li> <li>• MT 0384:</li> <li>• MT 4168:</li> <li>• MT 5067: A3P</li> <li>• MT 7516:</li> <li>• MT 7519:</li> </ul>	03T0895	1
Chinese-Simplified <ul style="list-style-type: none"> <li>• MT 0266:</li> <li>• MT 0384:</li> <li>• MT 4168:</li> <li>• MT 5067: A3C</li> <li>• MT 7516:</li> <li>• MT 7519:</li> </ul>	03T0896	1



Windows 7 Professional 64	FRU #	CRU
Chinese-Traditional <ul style="list-style-type: none"> <li>• MT 0266:</li> <li>• MT 0384:</li> <li>• MT 4168:</li> <li>• MT 5067: A3V</li> <li>• MT 7516:</li> <li>• MT 7519:</li> </ul>	03T0897	1
Czech <ul style="list-style-type: none"> <li>• MT 0266: D2G</li> <li>• MT 0384:</li> <li>• MT 4168:</li> <li>• MT 5067: A3G</li> <li>• MT 7516:</li> <li>• MT 7519: A2G A3G</li> </ul>	03T0898	1
India English <ul style="list-style-type: none"> <li>• MT 0266: D2G</li> <li>• MT 0384:</li> <li>• MT 4168:</li> <li>• MT 5067: A3Q</li> <li>• MT 7516:</li> <li>• MT 7519: A2G A3G</li> </ul>	03T0899	1
French <ul style="list-style-type: none"> <li>• MT 0266: D1F D2G D3F</li> <li>• MT 0384:</li> <li>• MT 4168:</li> <li>• MT 5067: A3G A3F</li> <li>• MT 7516: C5F</li> <li>• MT 7519: A2G A3G</li> </ul>	03T0900	1
Greek <ul style="list-style-type: none"> <li>• MT 0266: D2G</li> <li>• MT 0384:</li> <li>• MT 4168:</li> <li>• MT 5067: A3G</li> <li>• MT 7516:</li> <li>• MT 7519: A2G A3G</li> </ul>	03T0901	1

Windows 7 Professional 64	FRU #	CRU
German <ul style="list-style-type: none"> <li>• MT 0266: D2G</li> <li>• MT 0384:</li> <li>• MT 4168:</li> <li>• MT 5067: A3G</li> <li>• MT 7516:</li> <li>• MT 7519: A2G A3G</li> </ul>	03T0902	1
Hebrew <ul style="list-style-type: none"> <li>• MT 0266: D2G</li> <li>• MT 0384:</li> <li>• MT 4168:</li> <li>• MT 5067: A3G</li> <li>• MT 7516:</li> <li>• MT 7519: A2G A3G</li> </ul>	03T0903	1
Hong Kong <ul style="list-style-type: none"> <li>• MT 0266:</li> <li>• MT 0384:</li> <li>• MT 4168:</li> <li>• MT 5067: A3B</li> <li>• MT 7516:</li> <li>• MT 7519:</li> </ul>	03T0904	1
Hungary <ul style="list-style-type: none"> <li>• MT 0266: D2G</li> <li>• MT 0384:</li> <li>• MT 4168:</li> <li>• MT 5067: A3G</li> <li>• MT 7516:</li> <li>• MT 7519: A2G A3G</li> </ul>	03T0905	1
Italy <ul style="list-style-type: none"> <li>• MT 0266: D2G</li> <li>• MT 0384:</li> <li>• MT 4168:</li> <li>• MT 5067: A3G</li> <li>• MT 7516:</li> <li>• MT 7519: A2G A3G</li> </ul>	03T0906	1

Windows 7 Professional 64	FRU #	CRU
Japanese <ul style="list-style-type: none"> <li>• MT 0266: D4J D5J</li> <li>• MT 0384:</li> <li>• MT 4168:</li> <li>• MT 5067: A3J</li> <li>• MT 7516:</li> <li>• MT 7519:</li> </ul>	03T0907	1
Polish <ul style="list-style-type: none"> <li>• MT 0266: D2G</li> <li>• MT 0384:</li> <li>• MT 4168:</li> <li>• MT 5067: A3G</li> <li>• MT 7516:</li> <li>• MT 7519: A2G A3G</li> </ul>	03T0908	1
Portuguese <ul style="list-style-type: none"> <li>• MT 0266: D2G</li> <li>• MT 0384:</li> <li>• MT 4168:</li> <li>• MT 5067: A3G</li> <li>• MT 7516:</li> <li>• MT 7519: A2G A3G</li> </ul>	03T0909	1
Romanian <ul style="list-style-type: none"> <li>• MT 0266: D2G</li> <li>• MT 0384:</li> <li>• MT 4168:</li> <li>• MT 5067: A3G</li> <li>• MT 7516:</li> <li>• MT 7519: A2G A3G</li> </ul>	03T0910	1
Slovakian <ul style="list-style-type: none"> <li>• MT 0266: D2G</li> <li>• MT 0384:</li> <li>• MT 4168:</li> <li>• MT 5067: A3G</li> <li>• MT 7516:</li> <li>• MT 7519: A2G A3G</li> </ul>	03T0911	1

Windows 7 Professional 64	FRU #	CRU
Spanish <ul style="list-style-type: none"> <li>• MT 0266: D2G</li> <li>• MT 0384:</li> <li>• MT 4168:</li> <li>• MT 5067: A3G</li> <li>• MT 7516:</li> <li>• MT 7519: A2G A3G</li> </ul>	03T0912	1
Sebian-Latin <ul style="list-style-type: none"> <li>• MT 0266: D2G</li> <li>• MT 0384:</li> <li>• MT 4168:</li> <li>• MT 5067: A3G</li> <li>• MT 7516:</li> <li>• MT 7519: A2G A3G</li> </ul>	03T0913	1
Turkish <ul style="list-style-type: none"> <li>• MT 0266: D2G</li> <li>• MT 0384:</li> <li>• MT 4168:</li> <li>• MT 5067: A3G</li> <li>• MT 7516:</li> <li>• MT 7519: A2G A3G</li> </ul>	03T0914	1
US English <ul style="list-style-type: none"> <li>• MT 0266: D1U D2G D3U</li> <li>• MT 0384:</li> <li>• MT 4168:</li> <li>• MT 5067: A3U A3F A3L A3G A3M A3A A3Q A3H A3R A3E</li> <li>• MT 7516: C5U</li> <li>• MT 7519: A2G A3G</li> </ul>	03T0915	1
C&L Nordics (DK/FI/SV/NO/EN) <ul style="list-style-type: none"> <li>• MT 0266: D2G</li> <li>• MT 0384:</li> <li>• MT 4168:</li> <li>• MT 5067: A3G</li> <li>• MT 7516:</li> <li>• MT 7519: A2G A3G</li> </ul>	03T0916	1

Windows 7 Professional 64	FRU #	CRU
C&L EMEA (NL/FR/GR/IT/EN) <ul style="list-style-type: none"> <li>• MT 0266: D2G</li> <li>• MT 0384:</li> <li>• MT 4168:</li> <li>• MT 5067: A3G</li> <li>• MT 7516:</li> <li>• MT 7519: A2G A3G</li> </ul>	03T0917	1
C&L Croatian (EN/SL/CR) <ul style="list-style-type: none"> <li>• MT 0266: D2G</li> <li>• MT 0384:</li> <li>• MT 4168:</li> <li>• MT 5067: A3G</li> <li>• MT 7516:</li> <li>• MT 7519: A2G A3G</li> </ul>	03T0918	1

## Windows XP Professional Generic Recovery CD

Windows XP Professional Generic	FRU #	CRU
Simplified Chinese <ul style="list-style-type: none"> <li>• MT 0266:</li> <li>• MT 0384:</li> <li>• MT 4168:</li> <li>• MT 5067:</li> <li>• MT 7516:</li> <li>• MT 7519:</li> </ul>	03W7477	1
Greek <ul style="list-style-type: none"> <li>• MT 0266:</li> <li>• MT 0384:</li> <li>• MT 4168:</li> <li>• MT 5067:</li> <li>• MT 7516:</li> <li>• MT 7519:</li> </ul>	03W7483	1
Hungary <ul style="list-style-type: none"> <li>• MT 0266:</li> <li>• MT 0384:</li> <li>• MT 4168:</li> <li>• MT 5067:</li> <li>• MT 7516:</li> <li>• MT 7519:</li> </ul>	03W7486	1

Windows XP Professional Generic	FRU #	CRU
Korean <ul style="list-style-type: none"> <li>• MT 0266:</li> <li>• MT 0384:</li> <li>• MT 4168:</li> <li>• MT 5067:</li> <li>• MT 7516:</li> <li>• MT 7519:</li> </ul>	03W7489	1
Dutch <ul style="list-style-type: none"> <li>• MT 0266:</li> <li>• MT 0384:</li> <li>• MT 4168:</li> <li>• MT 5067:</li> <li>• MT 7516:</li> <li>• MT 7519:</li> </ul>	03W7490	1
Portuguese <ul style="list-style-type: none"> <li>• MT 0266:</li> <li>• MT 0384:</li> <li>• MT 4168:</li> <li>• MT 5067:</li> <li>• MT 7516:</li> <li>• MT 7519:</li> </ul>	03W7493	1

## Windows Vista Business 32 Recovery CD

Windows Vista Business 32	FRU #	CRU
India English <ul style="list-style-type: none"> <li>• MT 0266:</li> <li>• MT 0384:</li> <li>• MT 4168:</li> <li>• MT 5067:</li> <li>• MT 7516:</li> <li>• MT 7519:</li> </ul>	03T1311	1
US english <ul style="list-style-type: none"> <li>• MT 0266:</li> <li>• MT 0384:</li> <li>• MT 4168:</li> <li>• MT 5067:</li> <li>• MT 7516:</li> <li>• MT 7519:</li> </ul>	03T1312	1

## Windows Vista Home Basic 32 Recovery CD

Windows Vista Home Basic 32	FRU #	CRU
India English <ul style="list-style-type: none"> <li>• MT 0266:</li> <li>• MT 0384:</li> <li>• MT 4168:</li> <li>• MT 5067:</li> <li>• MT 7516:</li> <li>• MT 7519:</li> </ul>	03T1313	1
French <ul style="list-style-type: none"> <li>• MT 0266:</li> <li>• MT 0384:</li> <li>• MT 4168:</li> <li>• MT 5067:</li> <li>• MT 7516:</li> <li>• MT 7519:</li> </ul>	03T1314	1
Japanese <ul style="list-style-type: none"> <li>• MT 0266:</li> <li>• MT 0384:</li> <li>• MT 4168:</li> <li>• MT 5067:</li> <li>• MT 7516:</li> <li>• MT 7519:</li> </ul>	03T1315	1
Spanish <ul style="list-style-type: none"> <li>• MT 0266:</li> <li>• MT 0384:</li> <li>• MT 4168:</li> <li>• MT 5067:</li> <li>• MT 7516:</li> <li>• MT 7519:</li> </ul>	03T1316	1
US English <ul style="list-style-type: none"> <li>• MT 0266:</li> <li>• MT 0384:</li> <li>• MT 4168:</li> <li>• MT 5067:</li> <li>• MT 7516:</li> <li>• MT 7519:</li> </ul>	03T1317	1

Windows Vista Home Basic 32	FRU #	CRU
C&L1 Nordics: DK/FI/SV/NO/EN <ul style="list-style-type: none"> <li>• MT 0266:</li> <li>• MT 0384:</li> <li>• MT 4168:</li> <li>• MT 5067:</li> <li>• MT 7516:</li> <li>• MT 7519:</li> </ul>	03T1318	1
C&L2 EMEA: NL/FR/GR/IT/EN <ul style="list-style-type: none"> <li>• MT 0266:</li> <li>• MT 0384:</li> <li>• MT 4168:</li> <li>• MT 5067:</li> <li>• MT 7516:</li> <li>• MT 7519:</li> </ul>	03T1319	1



---

## Chapter 10. Additional service information

This chapter provides additional information that the service representative might find helpful.

---

### Security features

Security features in this section include the following:

- Passwords
- Vital Product Data
- Secure Managed Client (some models)

### Hardware-controlled passwords

Use the Setup Utility program to set the hardware-controlled passwords. For more information about passwords, see “Using passwords” on page 41.

### Operating system password

**Note:** This section applies only to computer models that have an operating system preinstalled from Lenovo.

An operating system password is very similar to a power-on password and denies access to the computer by an unauthorized user when the password is activated. The computer is unusable until the correct password is entered and recognized by the computer.

### Vital Product Data

Each computer has a unique Vital Product Data (VPD) code stored in the nonvolatile memory on the system board. After you replace the system board, the VPD must be updated. To update the VPD, see “Updating (flashing) the BIOS from a disc” on page 180.

### Secure Managed Client

The Secure Managed Client (SMC) is a storage-based, desktop computing solution that helps businesses reduce IT costs and improve security by turning off hard disk drives and storing all data in a non-server remote location while offering users the flexibility and performance of a traditional desktop computer. For computer models that do not have an internal hard disk drive and a preinstalled operating system, but use a remote hard disk drive accessed through the SMC - Storage Array, contact the network or storage administrator.

---

### BIOS levels

An incorrect level of BIOS can cause false errors and unnecessary FRU replacement. Use the following information to determine the current level of BIOS installed in the computer, the latest BIOS available for the computer, and where to obtain the latest level of BIOS.

- To determine the current level of BIOS:
  - Start the Setup Utility program.
  - See **BIOS Revision Level** on the main setup screen.
- Sources for obtaining the latest level BIOS available
  1. Lenovo support web site: <http://www.lenovo.com/support/>
  2. Lenovo Customer Support Center

### 3. Levels 1 and 2 Support

To update (flash) the BIOS, see “Updating (flashing) the BIOS from a disc” on page 180.

---

## Updating (flashing) the BIOS from a disc

This section provides instructions on how to update (flash) the BIOS from a disc.

**Note:** You can download a self-starting bootable disc image (known as an ISO image) with the system program updates to create a system-program-update disc. Go to:  
<http://www.lenovo.com/support>

To update (flash) the BIOS from a disc, do the following:

1. Turn off your computer.
2. Repeatedly press and release the F12 key when turning on the computer. When the **Startup Device Menu** opens, release the F12 key.
3. On the **Startup Device Menu**, select the desired optical drive as the startup device. Then, insert the disc into this optical drive and press Enter. The update begins.
4. When prompted to change the serial number, it is suggested that you do not make this change by pressing N. However, if you do want to change the serial number, press Y, then type in the serial number and press Enter.
5. When prompted to change the machine type and model, it is suggested that you do not make this change by pressing N. However, if you do want to change the machine type and model, press Y, then type in the machine type and model and press Enter.
6. Follow the instructions on the screen to complete the update. After the update is completed, remove the disc from the optical drive.

---

## Updating (flashing) the BIOS from your operating system

**Note:** Because Lenovo makes constant improvements to its Web sites, the Web page contents are subject to change without notice, including the contents referenced in the following procedure.

To update (flash) the BIOS from your operating system, do the following:

1. Go to <http://www.lenovo.com/support>.
2. Do the following to locate the downloadable files for your machine type:
  - a. Click **Download & Drivers**.
  - b. In the left pane, click **Downloads and drivers**.
  - c. From the **Brand** drop-down list box, select **Desktops**.
  - d. From the **Family** drop-down list box, select the family name.
  - e. Click **Continue**.
  - f. From the **Refine results** drop-down list box, select **BIOS**.
  - g. Click the BIOS update link.
3. Click the TXT file that contains the instructions for updating (flashing) the BIOS from your operating system.
4. Print these instructions. This is very important because these instructions will not be displayed on the screen after the download begins.
5. Follow the printed instructions to download, extract, and install the update.

---

## Recovering from a POST/BIOS update failure

If the power to your computer is interrupted while the POST and BIOS is being updated, your computer might not restart correctly. If this happens, perform the following procedure to recover from the POST and BIOS update failure. This procedure is commonly called Boot-block Recovery.

1. Remove all media from the drives and turn off all attached devices and the computer. Then, disconnect all power cords from electrical outlets and disconnect all cables that are connected to the computer.
2. Open the computer cover. See “Opening the computer cover” on page 72.
3. Locate the Clear CMOS /Recovery jumper on the system board. See “Locating parts on the system board” on page 71.
4. Remove any cables that impede access to the Clear CMOS /Recovery jumper.
5. Move the jumper from the standard position (pin 1 and pin 2) to the maintenance position (pin 2 and pin 3).
6. Reconnect any cables that were disconnected and reinstall the PCI card if removed.
7. Close the computer cover and reconnect the power cords for the computer and monitor to electrical outlets. See “Completing the parts replacement” on page 98.
8. Turn on the computer and then insert the POST and BIOS update (flash update) disc into the optical drive. The recovery session begins. The recovery session will take two to three minutes. During this time, you will hear a series of beeps.
9. After the recovery session is completed, the series of beeps will end, and the system will automatically turn off. Remove the disc from the optical drive before the system completely turns off.
10. Repeat step 1 through step 4.
11. Move the Clear CMOS /Recovery jumper back to the standard position (pin 1 and pin 2).
12. Reconnect any cables that were disconnected and reinstall the PCI card if removed.
13. Close the computer cover and reconnect any cables that were disconnected.
14. Turn on the computer to restart the operating system.

---

## Power management

Power management reduces the power consumption of certain components of the computer such as the system power supply, processor, hard disk drives, and some monitors.

### Automatic configuration and power interface (ACPI) BIOS

Being an ACPI BIOS system, the operating system is allowed to control the power management features of the computer and the setting for Advanced Power Management (APM) BIOS mode is ignored. Not all operating systems support ACPI BIOS mode.

### Automatic Power-On features

The Automatic Power-On features within the Power Management menu allow you to enable and disable features that turn on the computer automatically.

- **RTC resume:** You can specify a date and time at which the computer will be turned on automatically. This can be either a single event or a daily event.
- **Wake on LAN:** If the computer has a properly configured token-ring or Ethernet LAN adapter card that is Wake on LAN-enabled and there is remote network management software, you can use the Wake on LAN feature. When you set Wake on LAN to **Enabled**, the computer will turn on when it receives a specific signal from another computer on the local area network (LAN).



---

## Appendix A. Notices

Lenovo may not offer the products, services, or features discussed in this document in all countries. Consult your local Lenovo representative for information on the products and services currently available in your area. Any reference to a Lenovo product, program, or service is not intended to state or imply that only that Lenovo product, program, or service may be used. Any functionally equivalent product, program, or service that does not infringe any Lenovo intellectual property right may be used instead. However, it is the user's responsibility to evaluate and verify the operation of any other product, program, or service.

Lenovo may have patents or pending patent applications covering subject matter described in this document. The furnishing of this document does not give you any license to these patents. You can send license inquiries, in writing, to:

*Lenovo (United States), Inc.  
1009 Think Place - Building One  
Morrisville, NC 27560  
U.S.A.  
Attention: Lenovo Director of Licensing*

LENOVO PROVIDES THIS PUBLICATION "AS IS" WITHOUT WARRANTY OF ANY KIND, EITHER EXPRESS OR IMPLIED, INCLUDING, BUT NOT LIMITED TO, THE IMPLIED WARRANTIES OF NON-INFRINGEMENT, MERCHANTABILITY OR FITNESS FOR A PARTICULAR PURPOSE. Some jurisdictions do not allow disclaimer of express or implied warranties in certain transactions, therefore, this statement may not apply to you.

This information could include technical inaccuracies or typographical errors. Changes are periodically made to the information herein; these changes will be incorporated in new editions of the publication. Lenovo may make improvements and/or changes in the product(s) and/or the program(s) described in this publication at any time without notice.

The products described in this document are not intended for use in implantation or other life support applications where malfunction may result in injury or death to persons. The information contained in this document does not affect or change Lenovo product specifications or warranties. Nothing in this document shall operate as an express or implied license or indemnity under the intellectual property rights of Lenovo or third parties. All information contained in this document was obtained in specific environments and is presented as an illustration. The result obtained in other operating environments may vary.

Lenovo may use or distribute any of the information you supply in any way it believes appropriate without incurring any obligation to you.

Any references in this publication to non-Lenovo Web sites are provided for convenience only and do not in any manner serve as an endorsement of those Web sites. The materials at those Web sites are not part of the materials for this Lenovo product, and use of those Web sites is at your own risk.

Any performance data contained herein was determined in a controlled environment. Therefore, the result obtained in other operating environments may vary significantly. Some measurements may have been made on development-level systems and there is no guarantee that these measurements will be the same on generally available systems. Furthermore, some measurements may have been estimated through extrapolation. Actual results may vary. Users of this document should verify the applicable data for their specific environment.

---

## Television output notice

The following notice applies to models that have the factory-installed television-output feature.

This product incorporates copyright protection technology that is protected by method claims of certain U.S. patents and other intellectual property rights owned by Macrovision Corporation and other rights owners. Use of this copyright protection technology must be authorized by Macrovision Corporation, and is intended for home and other limited viewing uses only unless otherwise authorized by Macrovision Corporation. Reverse engineering or disassembly is prohibited.

---

## Trademarks

The following terms are trademarks of Lenovo in the United States, other countries, or both:

- Lenovo
- PS/2
- Rescue and Recovery
- The Lenovo logo
- ThinkCentre
- ThinkVantage

Wake on LAN is a trademark of International Business Machines Corporation in the United States, other countries, or both.

Celeron, Intel, and Intel Core are trademarks of Intel Corporation in the United States, other countries, or both.

Microsoft, Windows, and Windows Vista are trademarks of the Microsoft group of companies.

Other company, product, or service names may be trademarks or service marks of others.

---

# Index

## A

Administrator, password 42

## B

battery, replacing 80  
boot-block recovery 181

## C

cables, connecting 98  
changing  
    password 42  
    startup device sequence 44  
CMOS, clearing 43  
components, internal 71  
computer cover  
    opening 73  
connectors  
    rear 70  
connectors, controls, indicators  
    front 69  
considerations, passwords 42  
CRU  
    completing the installation 98

## D

deleting a password 42

## E

environment, operating 31  
exiting, Setup Utility 45

## F

failure, recovering from POST/BIOS 181  
flashing the BIOS 180  
front  
    connectors, controls, indicators 69  
front audio and USB assembly, replacing 92  
front fan assembly  
    replacing 88

## H

hard disk drive, replacing 77  
heat sink, replacing 81

## I

installing options  
    memory module 74

installing, replacing  
    PCI card 75  
internal speaker, replacing 91

## L

Lenovo ThinkVantage Toolbox 37  
Lenovo ThinkVantage Tools 29  
Lenovo Welcome 29  
locating components 71

## M

memory module  
    installing 74  
    system board 74  
microprocessor  
    replacing 82

## O

optical drive, replacing 78

## P

parts replacement, completing 98  
password  
    Administrator 42  
    considerations 42  
    Power-On Password 42  
    setting, changing, deleting 42  
passwords  
    erasing 43  
    lost or forgotten 43  
passwords, using 41  
PCI card 75  
    installing, replacing 75  
    slots 75  
physical specifications 31  
Power-On, Password 42  
productivity center, ThinkVantage 29

## R

rear connectors 70  
recovering  
    from a POST/BIOS update failure 181  
recovery  
    boot-block 181  
replacing  
    battery 80  
    front fan assembly 88  
    hard disk drive 77  
    heat sink 81  
    internal speaker 91

microprocessor 82

## S

- security
  - enabling or disabling 43
- selecting
  - startup device 44
  - temporary startup device 44
- setting
  - password 42
- settings
  - changing 41
  - viewing 41
- Setup Utility 41
- Setup Utility program, starting 41
- Setup Utility, exiting 45
- starting the Setup Utility program 41
- startup device 44
  - sequence, changing 44
  - temporary, selecting 44
- system board
  - connectors 72
  - locating parts 71
  - memory module 74

## T

- temporary startup device 44
- the BIOS, updating (flashing) 180
- ThinkVantage productivity center 29

## U

- updating
  - (flashing) the BIOS 180
- updating (flashing) the BIOS 180
- using
  - passwords 41
  - Setup Utility 41

## V

- viewing and changing settings 41





**lenovo**®

Part Number: 0A74394

Printed in USA

(1P) P/N: 0A74394

