

PYLE[®] plus

PLCD34

INSTRUCTION MANUAL

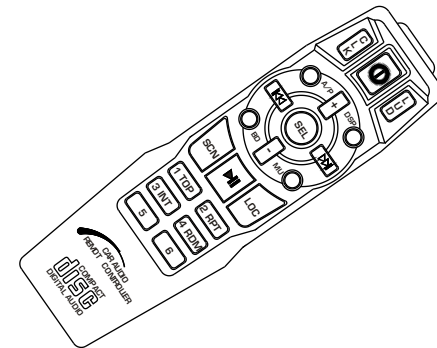
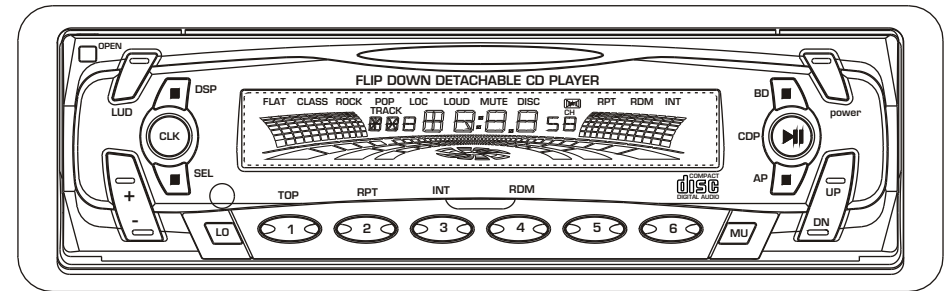

160WATTS

**ANTI-THEFT FLIP DOWN DETACHABLE SYSTEM
AUTO-LOADING COMPACT DISC PLAYER
AM/FM STEREO WITH DIGITAL TUNING RADIO
www.pyleaudio.com**

DEAR CUSTOMER:

Thank you for purchase and confidence in our all kinds of audio-visual products. Selecting fine audio equipment such as the unit you have just purchased is only the start of your musical enjoyment. Now it is time to consider how you can maximize the fun and excitement your equipment offers.

We hope you to get the most out of your equipment by playing it at a safe level. One that lets the sound come through loud and clear without annoying blare or distortion, and, more important, without affecting your sensitive hearing. Sound can be deceiving. Over time your hearing " comfort level " adapts to higher volumes of sound. So what sounds " normal " can actually be loud and harmful to your hearing. Guard against this by setting your equipment at a safe level **BEFORE** your hearing adapts.

To establish a safe level:

- Start your volume control at a low setting
- Slowly increase the sound until you can hear it comfortably and clearly, and without distortion we want you listening for a lifetime.

Once you have established a comfortable sound level:

- Set the dial and leave it there.

Taking a minute to do this now will help to prevent hearing damage or loss in the future. After all, we want you listening for a lifetime.

ABOUT THIS MANUAL

This product features a number of sophisticated functions ensuring superior reception and operation. All are designed for the easiest possible use, but many are not self-explanatory. This operation manual is intended to help you benefit fully from their potential and to maximize your listening enjoyment.

We recommend that you familiarize yourself with the functions and their operation by reading through the manual before you begin using this product. It is especially important that you read and observe the " precaution " on the next page and in other sections.

In this operation manual, the Basic Operation for each sound source is outlined at the beginning of its explanation, covering simple operation for that source, such as merely playing music.

**NOTE FOR RESET FUNCTION:
THE RESET FUNCTION IS ONLY AVAILABLE WHEN
THE FREQUENCY SWITCH (USA & EUROPE) IS USED.**

REMOTE CONTROL BASICS BATTERY REPLACEMENT:

- 1.Remove the battery holder as the direction indicated by the arrow.
- 2.Replace the battery Set a new battery properly with (+)side up as illustrated.
- 3.Insert the battery holder. Push in the holder to the original position.

NOTE ON BATTERIES:

Old batteries must immediately be removed and disposed.

BATTERY INFORMATION:

Designated Battery: UM-4"AAA"/R05

Battery Life: 6 months with normal use (in normal room temper atur)

CAUTION:

Improper use of batteries may cause overheating, explosion or ignition. Resulting in jury or fire .Battery leakage may cause damage to the unit.

Do not disassemble or short the batteries. Do not throw the batteries into the fire. To avoid the risk of accident, keep the batteries out of reach of children.

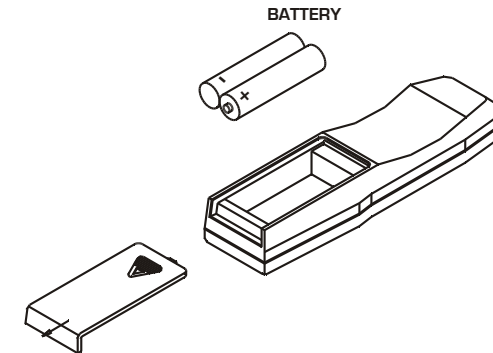

INSTALLATION

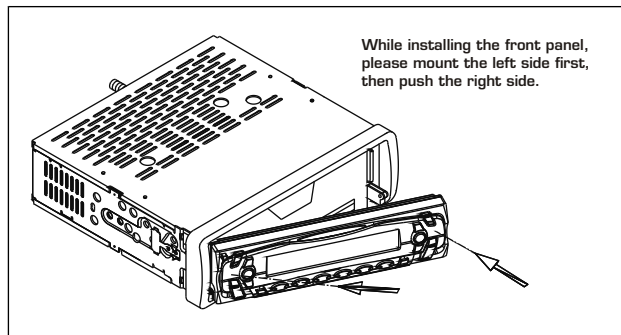
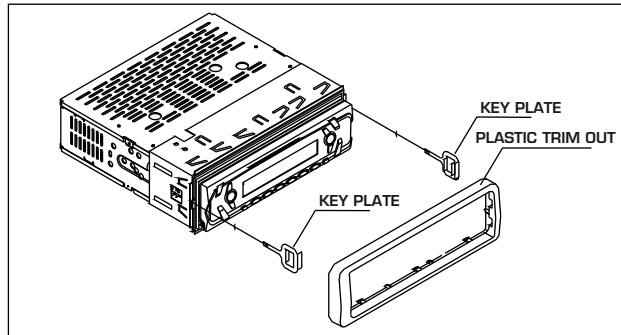
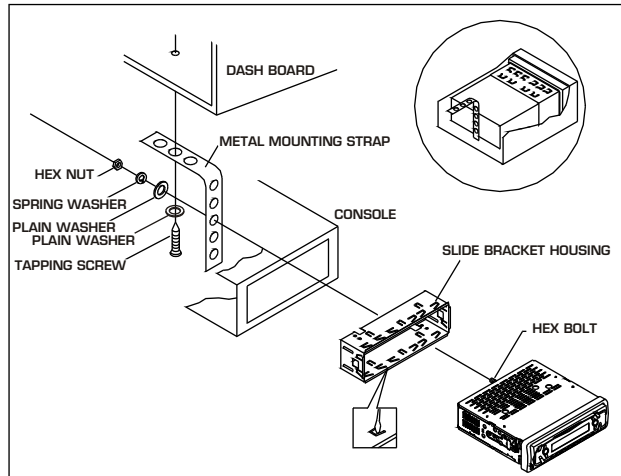

DISC PLAY:

Cleaning discs

Before playing, clean the disc with a clean, lint-free.

Flip the disc in the direction of the arrow.



NOTE:

- Do not use so solvents such as benzine, thinners. Commercially available cleaners or anti static spray damage the unit.
- Insert a disc with the label surface down. Doing so may damage the unit.

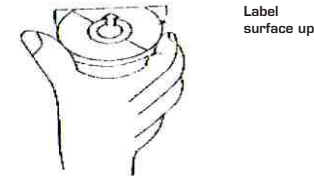

NOTE:

- Do not try to insert another disc when one has been already inserted. Doing so may damage the unit.
- Handle the disc by its edge. And to keep the disc clean, do not touch the surface.

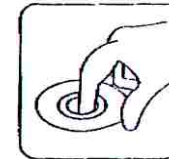

- Do not stick paper or tape on the disc.
- Do not expose the disc to direct sunlight or heat sources such as hot air ducts. Or leave it in a car parked in direct sunlight where there can be a considerable rise in temperature.

LOCATION AND FUNCTION OF CONTROLS

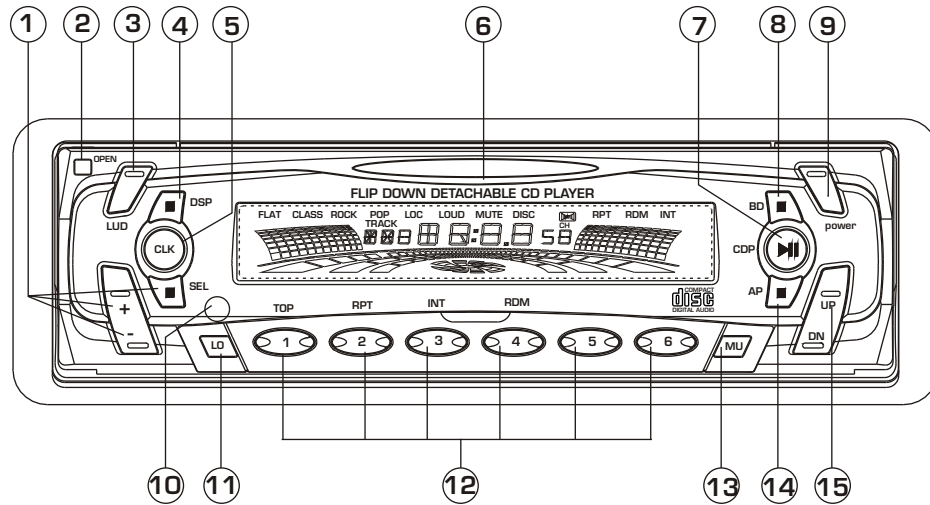

1. SEL (AUDIO MODE SELECT)/VOLUME +/- BUTTONS

Press SEL button to change the mode in the sequence of



- 1). The volume level can be adjusted at any time by pressing the audio level+ or - button as select mode has been initially defaulted at volume mode.
- 2). The volume level is also obtained by stepping through the SEL button until the character VOL is displayed and then press + or - button to adjust the sound level.
- 3). Press and hold the + or - button to adjust the sound level.

BASS CONTROL

- 1). Press the SEL button to select the bass mode until BAS appears on the display.
- 2). Press + or - to adjust the bass effect.

TREBLE CONTROL

- 1). Press the SEL button to select the treble mode until TRE appears on the display.
- 2). Press + or - to adjust the treble effect.

SPECIFICATION

GENERAL

Power requirement.....	DC 13.8V.
Current consumption.....	7A MAX.
Power output.....	40W X 4

FM SECTION

Frequency range.....	87.5MHz -108.0MHz(EUROPE).
Frequency range.....	87.5MHz -107.9MHz(USA).
Usable sensitivity.....	3uV.
I.F Frequency.....	10.7MHz.

AM(MW) SECTION

Frequency range.....	522KHz - 1620KHz(EUROPE).
Frequency range.....	530KHz - 1710KHz(USA).

LINE - OUT [OPTION]

Output.....	1000mV @ FM 10% THD POWER.
Impedance.....	600 ohm.

CD PLAYER

System.....	compact disc audio system.
Usable disc.....	compact disc.
Signal format.....	sampling frequency 44.1KHz. No of quantization bits 1bit.
Frequency characteristics.....	5-40Hz ≤ 5dB 10K-20KHz ≤ 5dB.
Signal to noise ratio.....	70dB [1KHz] [IEC - A net work].
Number of channels.....	2 STEREO.
Chassis dimensions.....	178[W] X 50[H] X 150[D].



IMPORTANT:

This radio is set to USA frequency by factory, if European frequency is required please flip the frequency step switch on the side of the unit.

After the switchover of the frequency switch, the frequency convert function will not be valid until the RESET button has been pressed.

TROUBLE SHOOTING

Before going through the check list, wiring connection, should any of the problem persist after check list has been made, consult your nearest service dealer.

Symptom	Cause	Solution
No power	The car ignition is not on.	If the power supply is properly connected to the car accessory switch the ignition key to " ACC "
	The fuse is blown	Replace the fuse
Disc cannot be loaded or ejected	Presence of CD disc inside the player	Remove the disc in the player then put a new upward
	Inserting the disc in upside down	Insert the compact disc with the label facing upward
	Compact disc is extremely dirty or defective	Clean the disc or try to play a new one
	Temperature inside the car is too high	Cool off until the ambient temperature returns to normal
No sound	Condensation	Leave the player off for an hour or so, then try again
	Volume is in minimum	Adjust volume to a desired level
The operation keys do not work	Wiring is not properly connected	Check wiring connection
	The built-in microcomputer is not operating properly due to noise	Press the RESET button front panel is not properly fix into its place
Sound skips	The installation angle is more than 30 degrees	Adjust the installation angle to less than 30 degrees
	The disc is extremely dirty or defective	Clean the compact disc/try to play a new one
The radio does not work the radio station automatic selection does not work	The antenna cable is not connected the signals are too weak	Insert the antenna cable firmly select a station manually

BALANCE CONTROL

- 1). Press the SEL button to select the balance mode until BAL appears on LCD.
- 2). Press the + button or - button to increase or decrease the sound level of left or right speaker.

FADER CONTROL

- 1). Press the SEL button to select the fader mode until FAD appears on LCD.
- 2). Press the + button or - button to increase or decrease the sound level of front or rear speaker.

2. OPEN BUTTON

Press it to flip down the front panel when you want to take away. Press it to flip down the front panel then you can insert a disc into the slot or eject a disc from the slot by pressing the EJ button which located the back of the panel.

3. LOUD(LOUDNESS) BUTTON

Press "LOUD" to enhance the bass sound effect while reduce the volume half level .

4. DSP(DISPLAY) BUTTON

Press it to apply these function, and press it continually to switch between 4 preset equalizer curves: FLAT POP, CLAS, ROCK. And the sound quality will be accordingly changed. (FLAT IS INITIAL DEFAULT)

5. CLOCK ADJUSTMENT BUTTONS

During RADIO or CD state, press this button to change to clock function. Hold this button for more than 2 seconds until the time flashes on LCD, then you can adjust Hours and Minutes by pressing UP and DN button. After adjustment, press this button to resume normal play state and remain the adjustment.

6. LCD (LIQUID CRYSTAL DISPLAY)

7. CD (CD PLAY, PAUSE) BUTTON

At radio mode, press  button to switch to CD mode. At CD mode, press it to pause the CD program and press it again to resume CD playback.

8. BAND BUTTON

During CD mode, press it to switch to radio mode.
During radio mode, press it to select your desired radio band and word which band is selected will be displayed on LCD.

9. POWER BUTTON

Press the button to turn on or off the unit.

10. INFRA-RED RECEIVING WINDOW

11. LOCAL/DISTANCE BUTTON

Press it for distance reception when you are located at weak signal location, depress it for a stronger signal.

12. PRESET STATION [1-6] / TOP, RPT, INT, RDM.

A). To memorize the current frequency, press and any one of the six preset buttons for more than 2 seconds.

B). To recall the preset memory, press one of the preset button [1-6].

C). TOP BUTTON

Press the button during playback to return to the first track of CD.

D). REPEAT BUTTON

Press the button to continuously repeat same track. Press again to stop repeating.

E). INT: Preview all tracks

Press INT to play first ten seconds of each track on current CD. Press it again to stop scanning to play your desired track.

F). Random button: play all tracks

Press it to play all tracks on CD in random order. Press again to stop random play

13. MUTE BUTTON

Press this button to eliminate the sound temporarily and press it again to resume normal play state.

14. AS/PS BUTTON

Select 6 strong stations and store them in current band.

Select a band(if needed)

Hold AS/PS button for more than 3 seconds. The news stations will replace the stations already stored in that band.

Scan stations in current band

Select a band(if needed).

Press AS/PS button for less than 3 seconds. Radio pauses for 5 seconds at each station. Press AS/PS again to stop scanning when desired stations is reached.

15. [TUNE/SEEK UP] BUTTON and TRACK UP BUTTON

1). The frequency scans up by one step when pressing UP button once (50k for Europe,200k for USA).

Hold it for more than 2 seconds to seek for a station of higher frequency.

2). During CD mode, press UP button allow you to track forwards.

Hold the UP button allow you to skip forwards.

[TUNE/SEEK DOWN] BUTTON and TRACK DOWN BUTTON

1). The frequency scans down by one step when pressing DN button once(50k for Europe,200k for USA).

Hold it for more than 2 seconds to seek for a station of lower frequency.

2). During CD mode, press DN button allow you to track backwards.

Hold the DN button allow you to skip backwards.

Speaker Connection

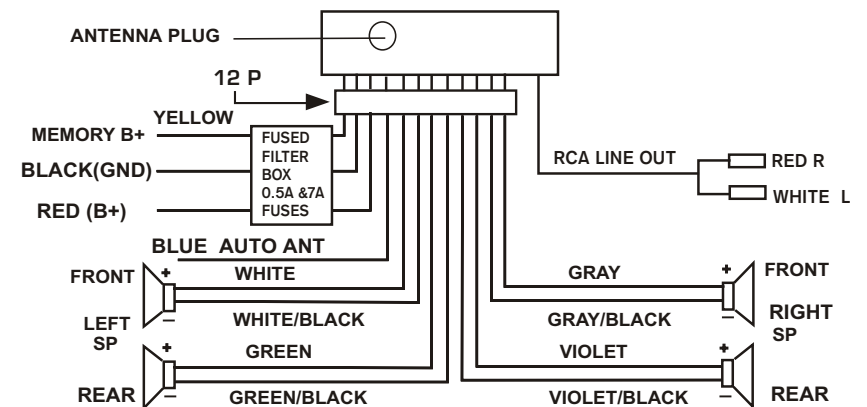

NOTE:

Make sure use a 4-ohm impedance speaker in spite of having any kinds of speaker system to reduce the distortion during high volume level.