

WESLO[®]

cadence G-40

Model No. WCTL29607.0

Serial No. _____

Write the serial number in the space above for future reference.

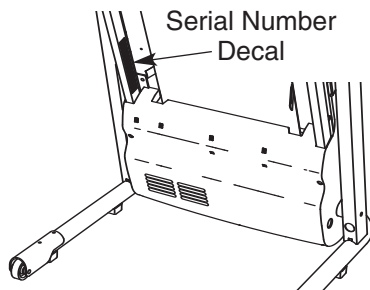

USER'S MANUAL

QUESTIONS?

As a manufacturer, we are committed to providing complete customer satisfaction. If you have questions, or if parts are damaged or missing, PLEASE CONTACT OUR CUSTOMER SERVICE DEPARTMENT DIRECTLY.

CALL TOLL-FREE:

1-888-936-4266

Mon.-Fri., 8:00 until 17:00 EST
(excluding holidays)

OR E-MAIL US:

customerservice@iconcanada.ca



CAUTION

Read all precautions and instructions in this manual before using this equipment. Save this manual for future reference.



Visit our website at
www.weslo.com

TABLE OF CONTENTS

WARNING DECAL PLACEMENT2

IMPORTANT PRECAUTIONS3

BEFORE YOU BEGIN5

ASSEMBLY6

OPERATION AND ADJUSTMENT12

HOW TO FOLD AND MOVE THE TREADMILL17

TROUBLESHOOTING19

EXERCISE GUIDELINES21

PART LIST23

EXPLODED DRAWING24

ORDERING REPLACEMENT PARTS Back Cover

LIMITED WARRANTY Back Cover

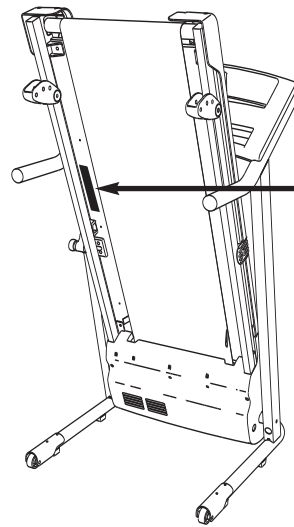

WARNING DECAL PLACEMENT

The decal shown here has been applied in the location shown. **If the decal is missing or illegible, call the telephone number on the front cover of this manual and request a free replacement decal. Apply the decal in the location shown.** Note: The decal may not be shown at actual size.



▲WARNING:

Protect yourself and others from risk of serious injury. Read the user's manual and :

- 
 - Stand only on the side rails when starting or stopping treadmill.
 - Change speed in small increments.
 - Hold handrails to prevent falling, and always wear the safety clip while operating treadmill.
 - Stop if you feel faint, dizzy, or short of breath.
 - Fully engage storage latch before treadmill is moved or stored.
 - Reduce incline to its lowest level before folding treadmill into storage position.
- 
 - Never allow children on or around treadmill.
 - Remove key when not in use.
- 
 - Keep clothing, fingers, and hair away from moving belt.
 - Never try to adjust or fix the belt while it is moving.
 - Always wear athletic shoes while operating treadmill.

IMPORTANT PRECAUTIONS

⚠️WARNING: To reduce the risk of serious injury, read all important precautions and instructions in this manual and all warnings on your treadmill before using your treadmill. ICON assumes no responsibility for personal injury or property damage sustained by or through the use of this product.

1. Before beginning any exercise program, consult your physician. This is especially important for persons over the age of 35 or persons with pre-existing health problems.
2. It is the responsibility of the owner to ensure that all users of this treadmill are adequately informed of all warnings and precautions.
3. Use the treadmill only as described.
4. Place the treadmill on a level surface, with at least 8 ft (2.4 m) of clearance behind it and 2 ft. (0.5 m) on each side. Do not place the treadmill on any surface that blocks air openings. To protect the floor or carpet from damage, place a mat under the treadmill.
5. Keep the treadmill indoors, away from moisture and dust. Do not put the treadmill in a garage or covered patio, or near water.
6. Do not operate the treadmill where aerosol products are used or where oxygen is being administered.
7. Keep children under the age of 12 and pets away from the treadmill at all times.
8. The treadmill should not be used by persons weighing more than 250 lbs. (113 kg).
9. Never allow more than one person on the treadmill at a time.
10. Wear appropriate exercise clothes when using the treadmill. Do not wear loose clothes that could become caught in the treadmill. Athletic support clothes are recommended for both men and women. *Always wear athletic shoes; never use the treadmill with bare feet, wearing only stockings, or in sandals.*
11. When connecting the power cord (see page 12), plug the power cord into a surge suppressor (not included) and plug the surge suppressor into a grounded circuit capable of carrying 15 or more amps. No other appliance should be on the same circuit. Do not use an extension cord.
12. Use only a single-outlet surge suppressor that meets all of the specifications described on page 12.
13. Failure to use a properly functioning surge suppressor could result in damage to the control system of the treadmill. If the control system is damaged, the walking belt may change speed, accelerate, or stop unexpectedly, which may result in a fall and serious injury.
14. Keep the power cord and the surge suppressor away from heated surfaces.
15. Never move the walking belt while the power is turned off. Do not operate the treadmill if the power cord or plug is damaged, or if the treadmill is not working properly. (See TROUBLESHOOTING on page 19 if the treadmill is not working properly.)
16. Read, understand, and test the emergency stop procedure before using the treadmill (see HOW TO TURN ON THE POWER on page 13).
17. Never start the treadmill while you are standing on the walking belt. Always hold the handrails while using the treadmill.
18. The pulse sensor is not a medical device. Various factors, including your movement, may affect the accuracy of heart rate readings. The pulse sensor is intended only as an exercise aid in determining heart rate trends in general.
19. The treadmill is capable of high speeds. Adjust the speed in small increments to avoid sudden jumps in speed.

20. Never leave the treadmill unattended while it is running. Always remove the key, unplug the power cord, and switch the reset/off circuit breaker to the off position when the treadmill is not in use. (See the drawing on page 5 for the location of the circuit breaker.)
21. Do not attempt to raise, lower, or move the treadmill until it is properly assembled. (See ASSEMBLY on page 6 and HOW TO FOLD AND MOVE THE TREADMILL on page 17.) You must be able to safely lift 45 lbs. (20 kg) to raise, lower, or move the treadmill.
22. When folding or moving the treadmill, make sure that the storage latch is fully closed.
23. Do not change the incline of the treadmill by placing objects under the treadmill.
24. Inspect and properly tighten all parts of the treadmill regularly.
25. Never drop or insert any object into any opening on the treadmill.
26. **DANGER:** Always unplug the power cord immediately after use, before cleaning the treadmill, and before performing the maintenance and adjustment procedures described in this manual. Never remove the motor hood unless instructed to do so by an authorized service representative. Servicing other than the procedures in this manual should be performed by an authorized service representative only.
27. This treadmill is intended for in-home use only. Do not use this treadmill in any commercial, rental, or institutional setting.

SAVE THESE INSTRUCTIONS

BEFORE YOU BEGIN

Thank you for selecting the new WESLO® CADENCE G-40 treadmill. The CADENCE G-40 treadmill combines advanced technology with innovative design to help you get the most from your exercise in the convenience of your home. And when you're not exercising, the CADENCE G-40 treadmill can be folded up, requiring less than half the floor space of other treadmills.

For your benefit, read this manual carefully before using the treadmill. If you have questions after read-



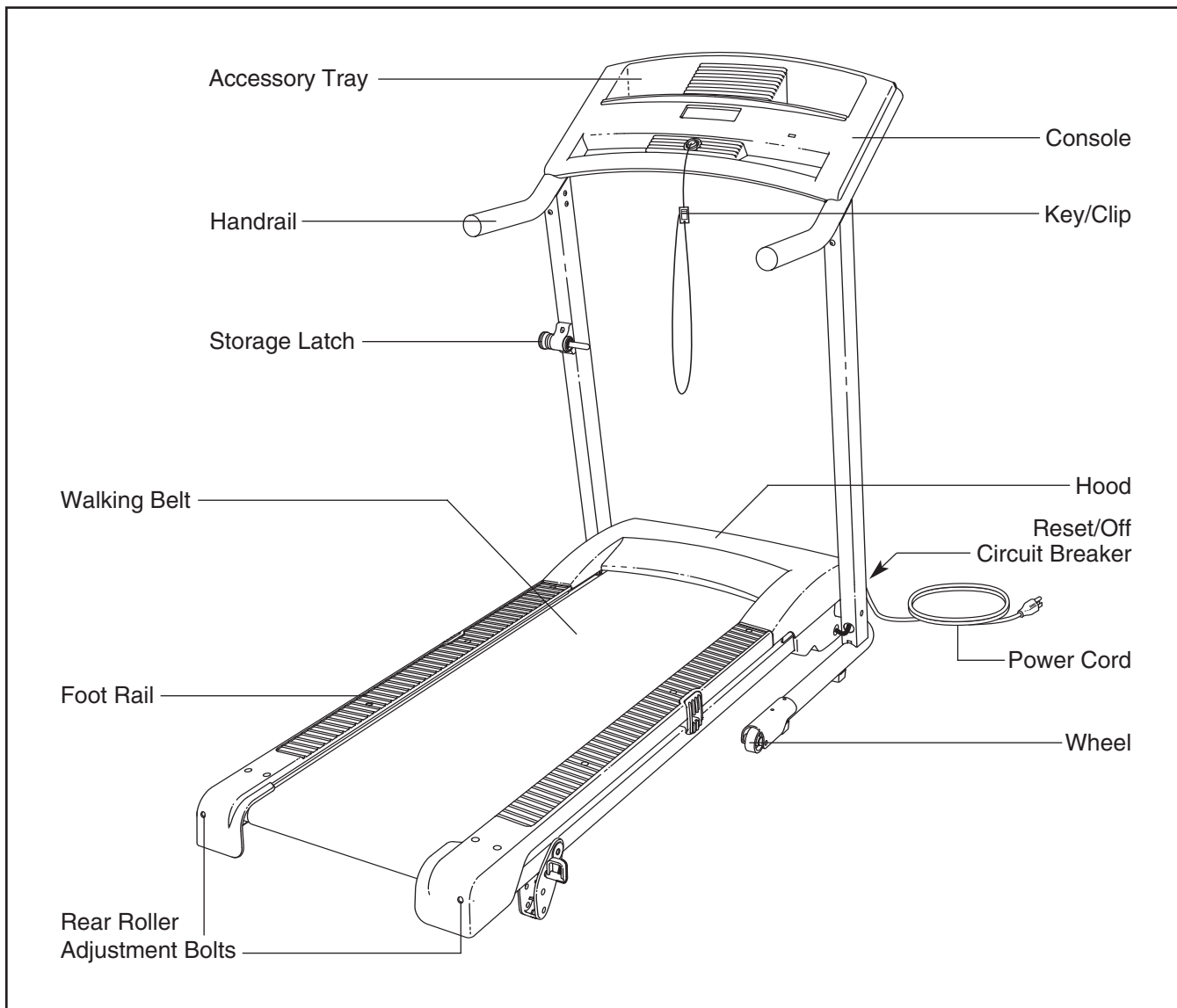

ing this manual, please see the front cover of this manual. To help us assist you, note the product model number and serial number before contacting us. The model number and the location of the serial number decal are shown on the front cover of this manual.

Before reading further, please review the drawing below and familiarize yourself with the labeled parts.



ASSEMBLY

Assembly requires two persons. Set the treadmill in a cleared area and remove all packing materials; **do not dispose of the packing materials until assembly is completed.** Note: The underside of the treadmill walking belt is coated with high-performance lubricant. During shipping, a small amount of lubricant may be transferred to the top of the walking belt or the shipping carton. This does not affect treadmill performance. If there is lubricant on top of the walking belt, simply wipe off the lubricant with a soft cloth and a mild, non-abrasive cleaner.

Assembly requires the included hex keys , and your own Phillips screwdriver , adjustable wrench , and needlenose pliers .

Use the drawings below to identify the assembly hardware. The number in parentheses below each drawing is the key number of the part, from the PART LIST near the end of the manual. The number after the parentheses shows the quantity needed for assembly. **Note: If a part is not in the parts bag, check to see if it is pre-attached to one of the parts to be assembled. Extra hardware may be included. To avoid damaging plastic parts, do not use power tools for assembly.**

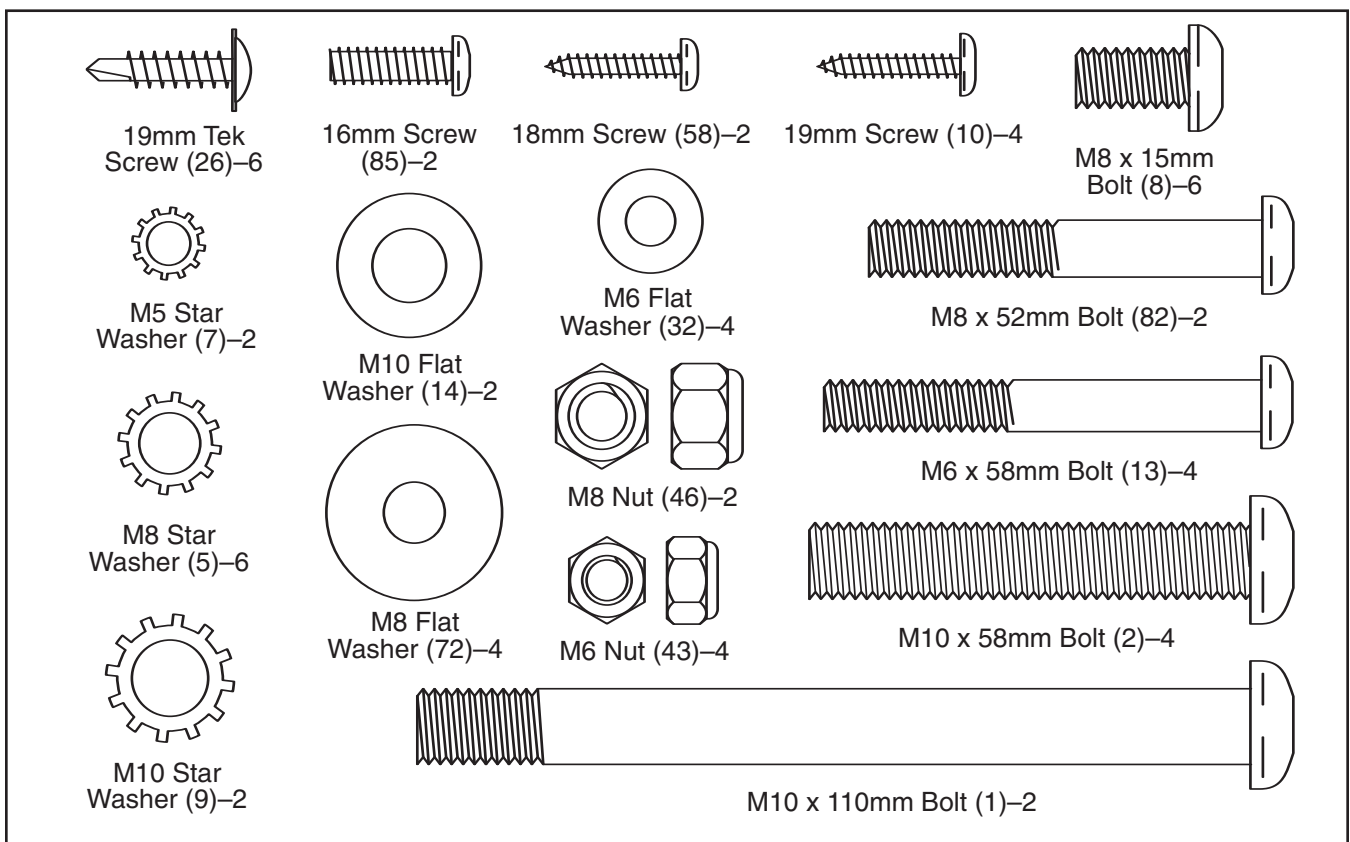

- 1. Make sure that the power cord is unplugged. Place a piece of cardboard under the treadmill frame to protect the floor during assembly.**

Have a second person hold the Base (52) in the position shown.

Attach six Base Pads (63) to the Base (52) with six 19mm Tek Screws (26).

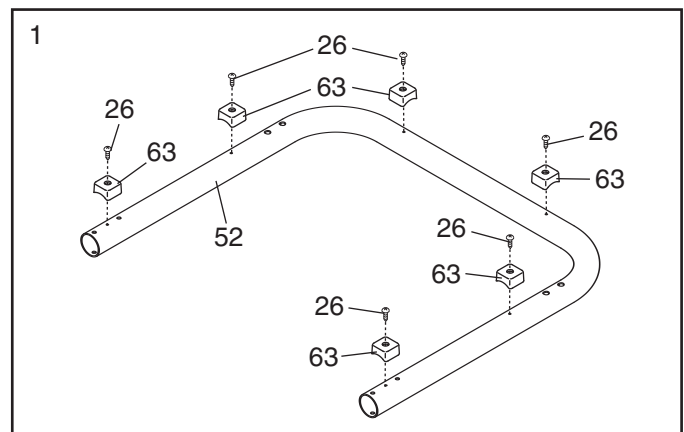

2. Have a second person hold the Base (52) in the position shown.

Identify the Left Upright (53) (the Right Upright [54] has a large hole near the lower end).

Hold the Left Upright (53) so that the two indicated small holes are on top. Attach the Left Upright to the Base (52) with two M10 x 58mm Bolts (2). **Do not tighten the Bolts yet.**

Attach the Right Upright (54) to the Base (52) in the same way.

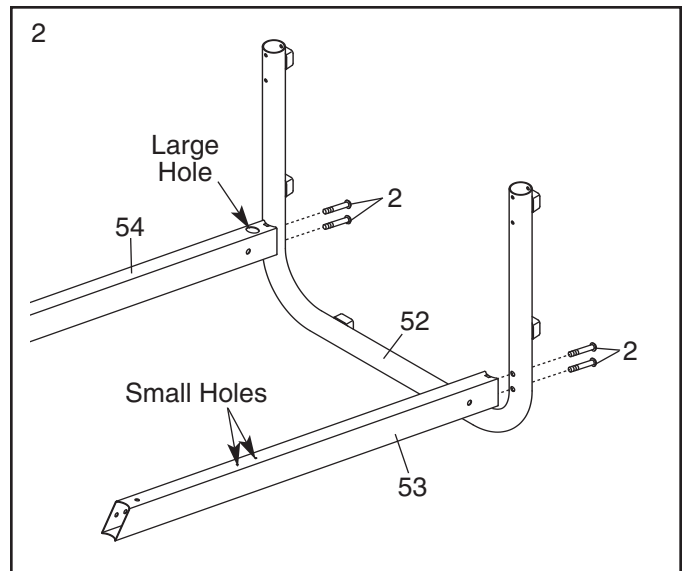

3. Slide the two Wheel Housings (45) onto the Base (52). Attach each Wheel Housing with two M6 x 58mm Bolts (13), two M6 Flat Washers (32), and two M6 Nuts (43).

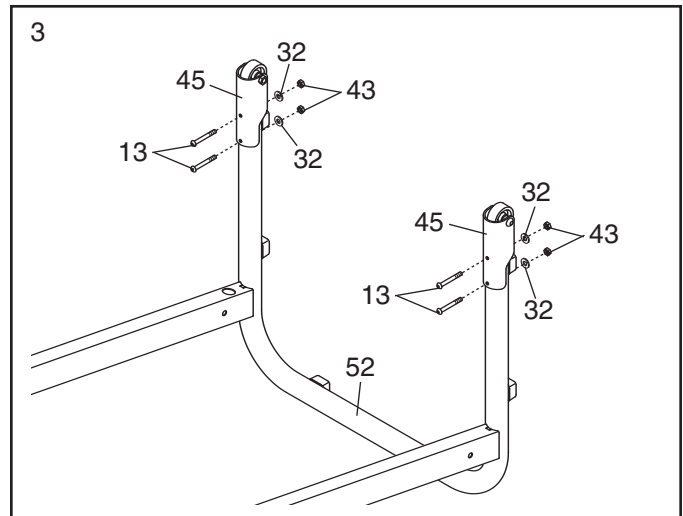

4. Remove the bolts and the cardboard packaging from both sides of the Hood (65). Discard the bolts.

Position the Base (52) as close to the front of the treadmill as possible.

See the inset drawing. Locate the wire tie in the Right Upright (54). Tie the wire tie securely to the connector on the end of the Wire Harness (39). Next, pull the opposite end of the wire tie out of the upper end of the Right Upright, until the Wire Harness is routed completely through the Right Upright. Secure the Wire Harness to the Right Upright so that it will not fall inside.

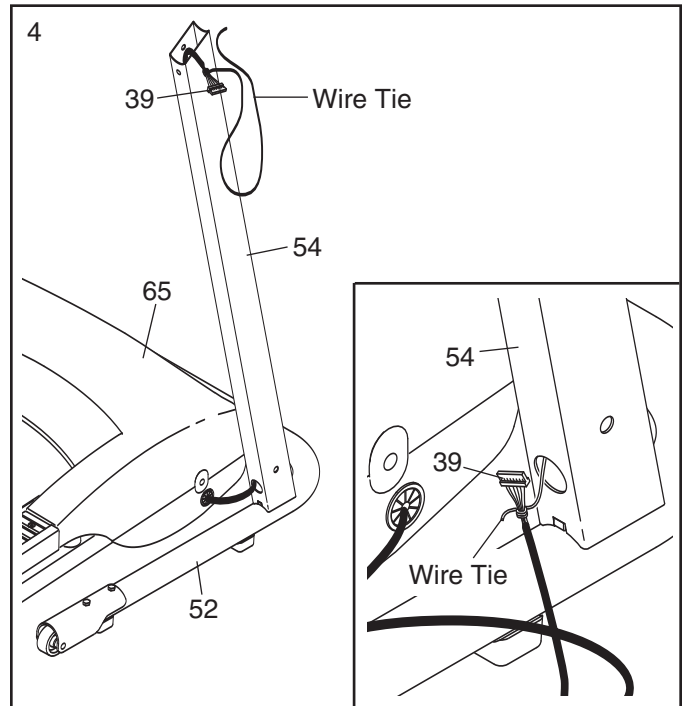

5. **See the left inset drawing.** Identify a Frame Spacer (11). Hold the Frame Spacer between the Right Upright (54) and the Frame (51). With the help of a second person, raise the front of the Frame until steps 5 and 6 are completed.

Attach the Right Upright (54) to the Frame (51) with an M10 x 110mm Bolt (1), an M10 Flat Washer (14), and an M10 Star Washer (9); **do not tighten the Bolt yet.**

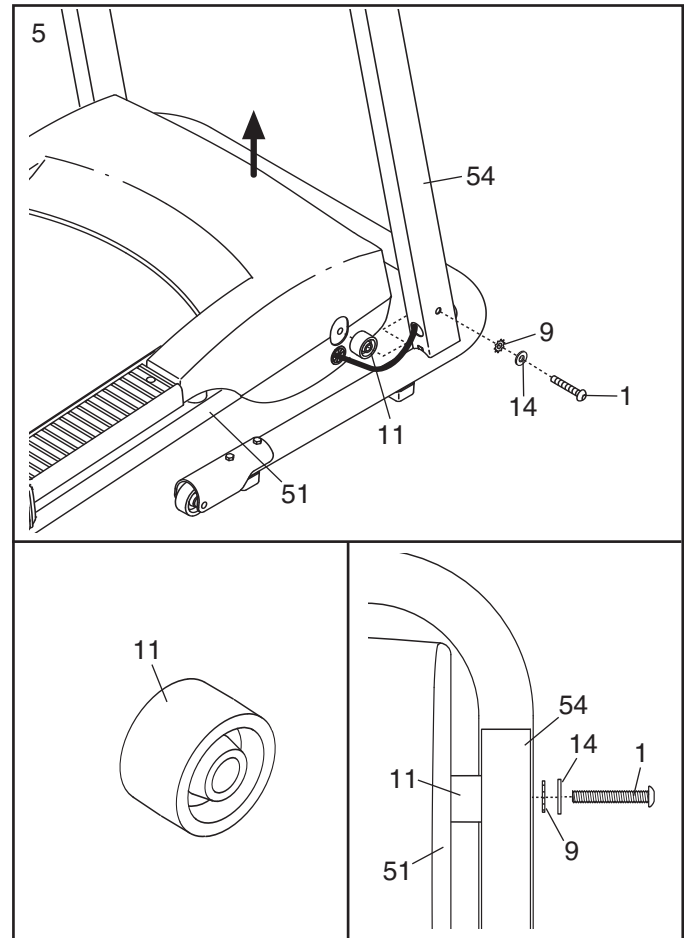

6. Hold the other Frame Spacer (11) between the Left Upright (53) and the Frame (51). Attach the Left Upright to the Frame with an M10 x 110mm Bolt (1), an M10 Flat Washer (14), and an M10 Star Washer (9); **do not tighten the Bolt yet.**

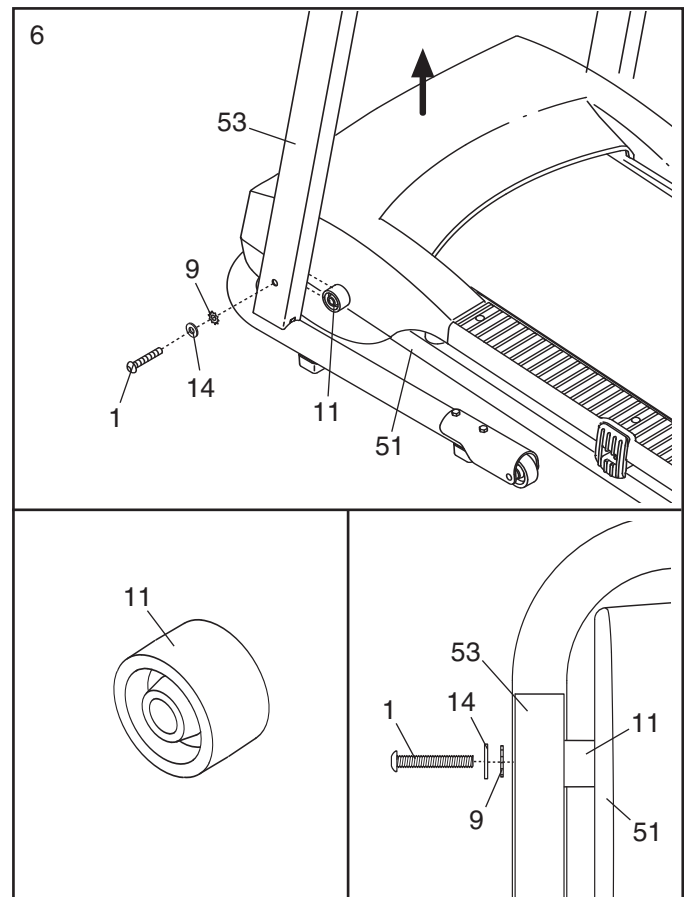

7. Set the Console (91) face down on a soft surface to avoid scratching it. Hold the Right Handrail (33), which has a large hole in the location shown, near the Console.

Next, insert the console wire into the large hole in the side of the Right Handrail (33). Using needlenose pliers, grasp the tie inside the Right Handrail and pull the connector to the hole near the bracket on the Right Handrail. Carefully grasp the connector with the pliers and pull the console wire out of the hole.

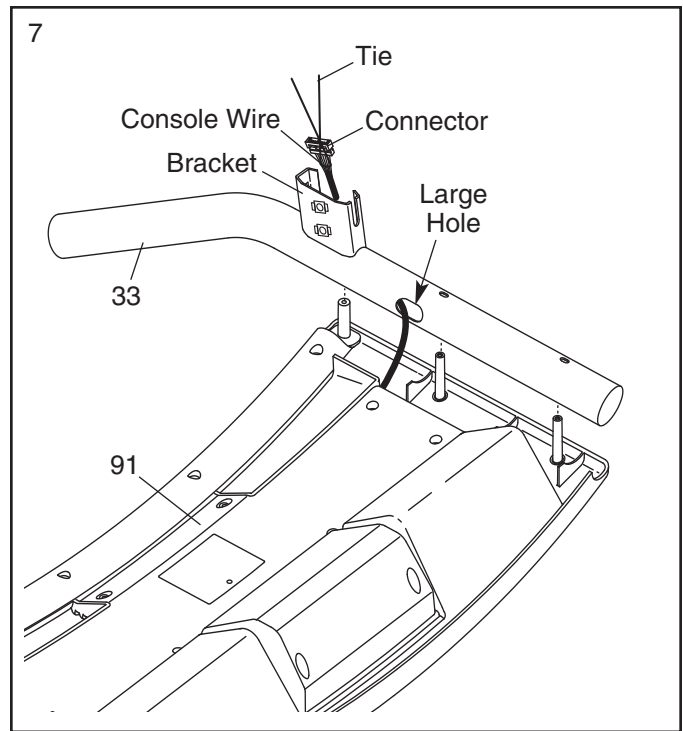

8. Set the Right Handrail (33) on the Console (91). **Make sure that the console wire is not pinched.** Start a 16mm Screw (85) with an M5 Star Washer (7) into the Right Handrail, and then start two 19mm Screws (10) into the Right Handrail. **Tighten the 16mm Screw and then tighten the two 19mm Screws; do not over-tighten the Screws.**

Attach the Left Handrail (not shown) to the Console (91) in the same way. Note: There is no console wire on the left side.

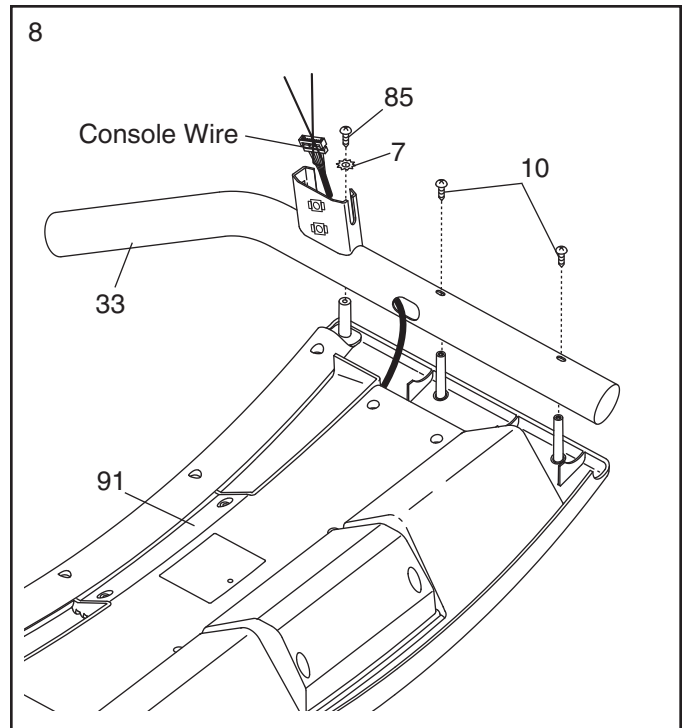

9. With the help of a second person, hold the Console (91) near the Right Upright (54).

Remove the wire tie from the Wire Harness (39) and the console wire. Connect the Wire Harness to the console wire. **See the inset drawing.** **The connectors should slide together easily and snap into place.** If they do not, turn one connector and try again. **IF THE CONNECTORS ARE NOT CONNECTED PROPERLY, THE CONSOLE MAY BE DAMAGED WHEN THE POWER IS TURNED ON.** Insert the connectors and the excess wire downward into the Right Upright (54).

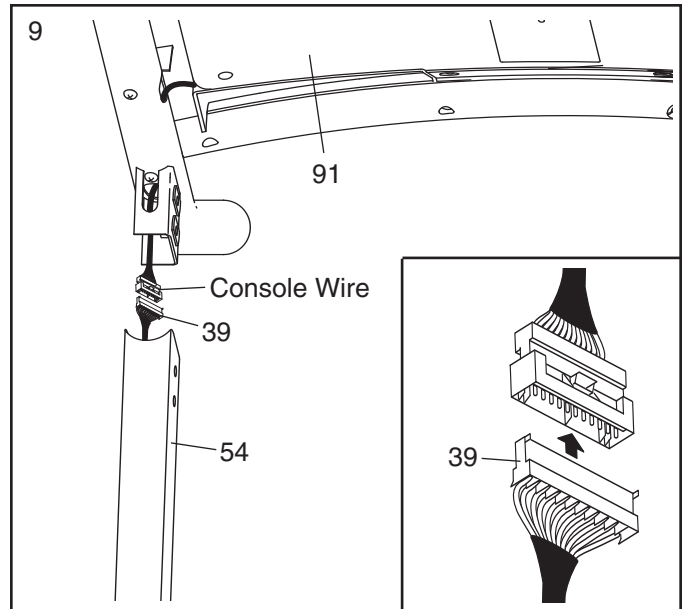

10. Set the Console (91) on the Uprights (53, 54). **Make sure that no wires are pinched.** Start four M8 x 15mm Bolts (8) with four M8 Star Washers (5) into the Uprights as shown. **Do not tighten the Bolts yet.**

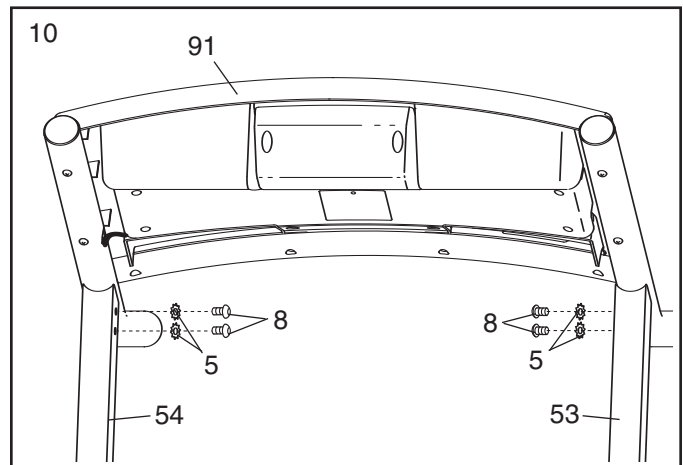

11. Start two M8 x 15mm Bolts (8) with two M8 Star Washers (5) into the Uprights (53, 54). **Then, firmly tighten all six Bolts from steps 10 and 11.**

With the help of a second person, carefully lower the Uprights (53, 54) to the floor.

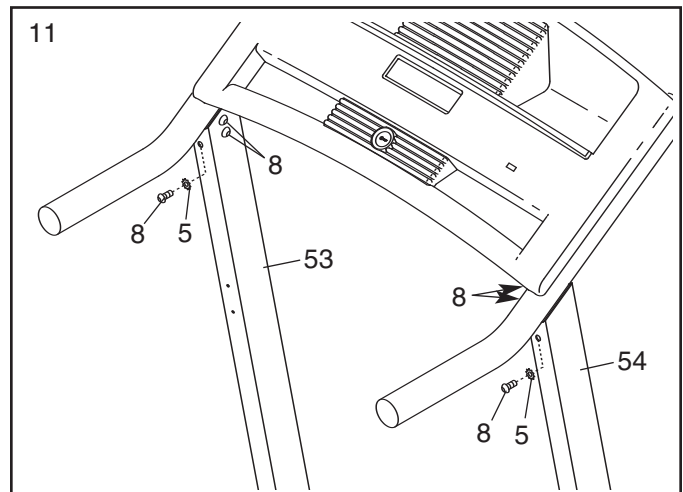

12. **See the lower drawing.** Position the Uprights (53, 54) so that the treadmill Frame (51) is centered between the Uprights.

Firmly tighten the two M10 x 110mm Bolts (1) and the four M10 x 58mm Bolts (2). **Be careful not to overtighten the M10 x 110mm Bolts.**

With the help of a second person, raise the Uprights (53, 54) to a vertical position.

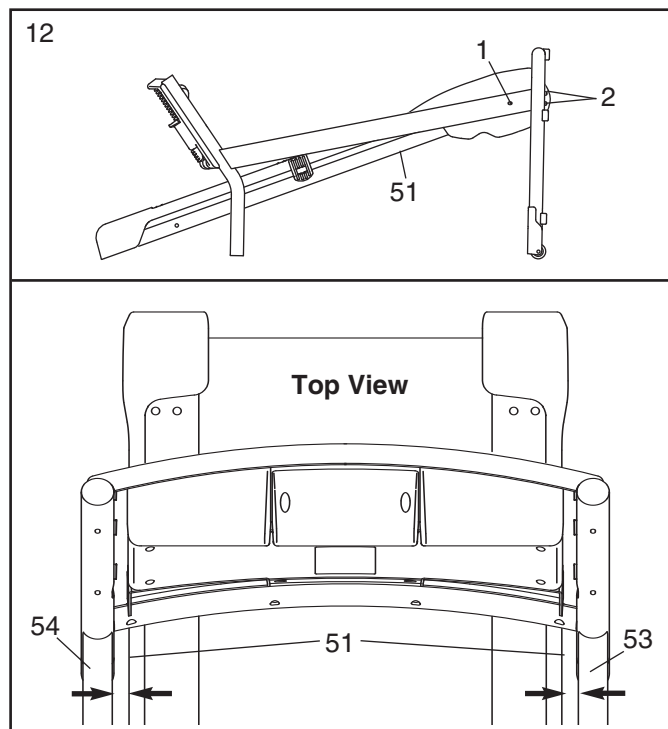

13. Attach the Latch Housing (48) to the Left Upright (53) with two 18mm Screws (58); **start both Screws before tightening either of them.**

Remove the knob from the pin. Make sure that the collar and the spring are on the pin. Insert the pin into the Latch Housing (48), and tighten the knob back onto the pin.

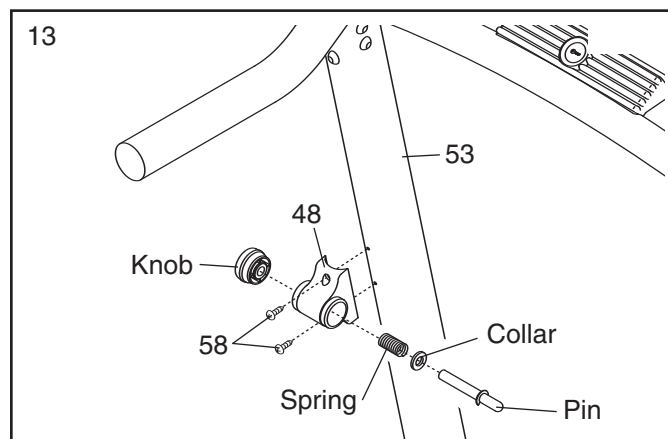

14. Raise the treadmill to the storage position (see HOW TO FOLD THE TREADMILL FOR STORAGE on page 17). Attach an Incline Leg (95) to each side of the Frame (51) with an M8 x 52mm Bolt (82), two M8 Flat Washers (72), and an M8 Nut (46) as shown. **Note: do not overtighten the Nuts. The Incline Leg should be able to rotate easily.**

Adjust the Incline Legs (95) to the desired incline (see page 16).

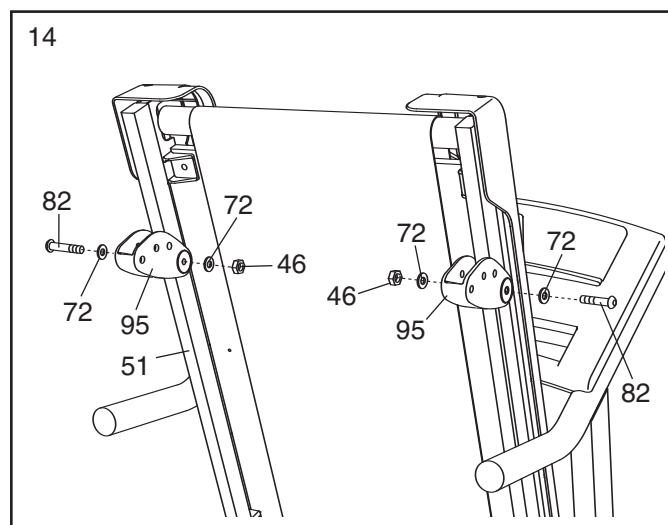

15. **Make sure that all parts are properly tightened before you use the treadmill.** Keep the included hex keys in a secure place. The hex key is used to adjust the walking belt (see page 20). To protect the floor or carpet, place a mat under the treadmill.

OPERATION AND ADJUSTMENT

THE PRE-LUBRICATED WALKING BELT

Your treadmill features a walking belt coated with high-performance lubricant. **IMPORTANT: Never apply silicone spray or other substances to the walking belt or the walking platform. Such substances will deteriorate the walking belt and cause excessive wear.**

HOW TO PLUG IN THE POWER CORD

⚠ DANGER: Improper connection of the equipment-grounding conductor can result in an increased risk of electric shock. Check with a qualified electrician or serviceman if you are in doubt as to whether the product is properly grounded. Do not modify the plug provided with the product—if it will not fit the outlet, have a proper outlet installed by a qualified electrician.

Your treadmill, like any other type of sophisticated electronic equipment, can be seriously damaged by sudden voltage changes in your home's power. Voltage surges, spikes, and noise interference can result from weather conditions or from other appliances being turned on or off. **To decrease the possibility of your treadmill being damaged, always use a surge suppressor with your treadmill (see drawing 1 at the right).**

Use only a single-outlet surge suppressor that is UL 1449 listed as a transient voltage surge suppressor (TVSS). The surge suppressor must have a UL suppressed voltage rating of 400 volts or less and a minimum surge dissipation of 450 joules. The surge suppressor must be electrically rated for 120 volts AC and 15 amps. There must be a monitoring light on the surge suppressor to indicate whether it is functioning properly. Failure to use a properly functioning surge suppressor could result in damage to the control system of the treadmill. If the control system is damaged, the walking belt may change speed, accelerate or stop unexpectedly, which may result in a fall and serious injury.

This product must be grounded. If it should malfunction or break down, grounding provides a path of least resistance for electric current to reduce the risk of electric shock. This product is equipped with a cord having an equipment-grounding conductor and a grounding plug. **Plug the power cord into a surge suppressor, and plug the surge suppressor into an appropriate**

outlet that is properly installed and grounded in accordance with all local codes and ordinances. Important: The treadmill is not compatible with GFCI-equipped outlets.

This product is for use on a nominal 120-volt circuit, and has a grounding plug that looks like the plug illustrated in drawing 1 below. A temporary adapter that looks like the adapter illustrated in drawing 2 may be used to connect the surge suppressor to a 2-pole receptacle as shown in drawing 2 if a properly grounded outlet is not available.

The temporary adapter should be used only until a properly grounded outlet (drawing 1) can be installed by a qualified electrician.

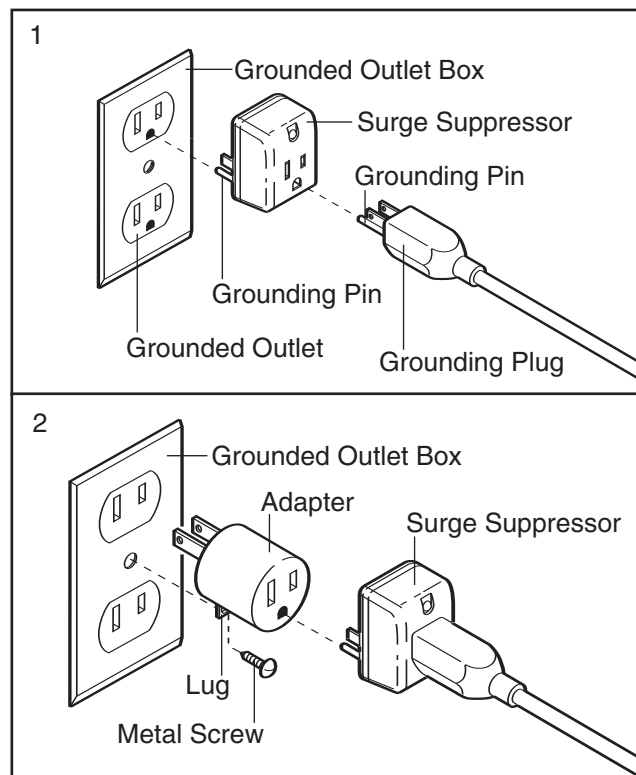

The green-colored rigid ear, lug, or the like extending from the adapter must be connected to a permanent ground such as a properly grounded outlet box cover. Whenever the adapter is used it must be held in place by a metal screw. **Some 2-pole receptacle outlet box covers are not grounded. Contact a qualified electrician to determine if the outlet box cover is grounded before using an adapter.**

CONSOLE DIAGRAM

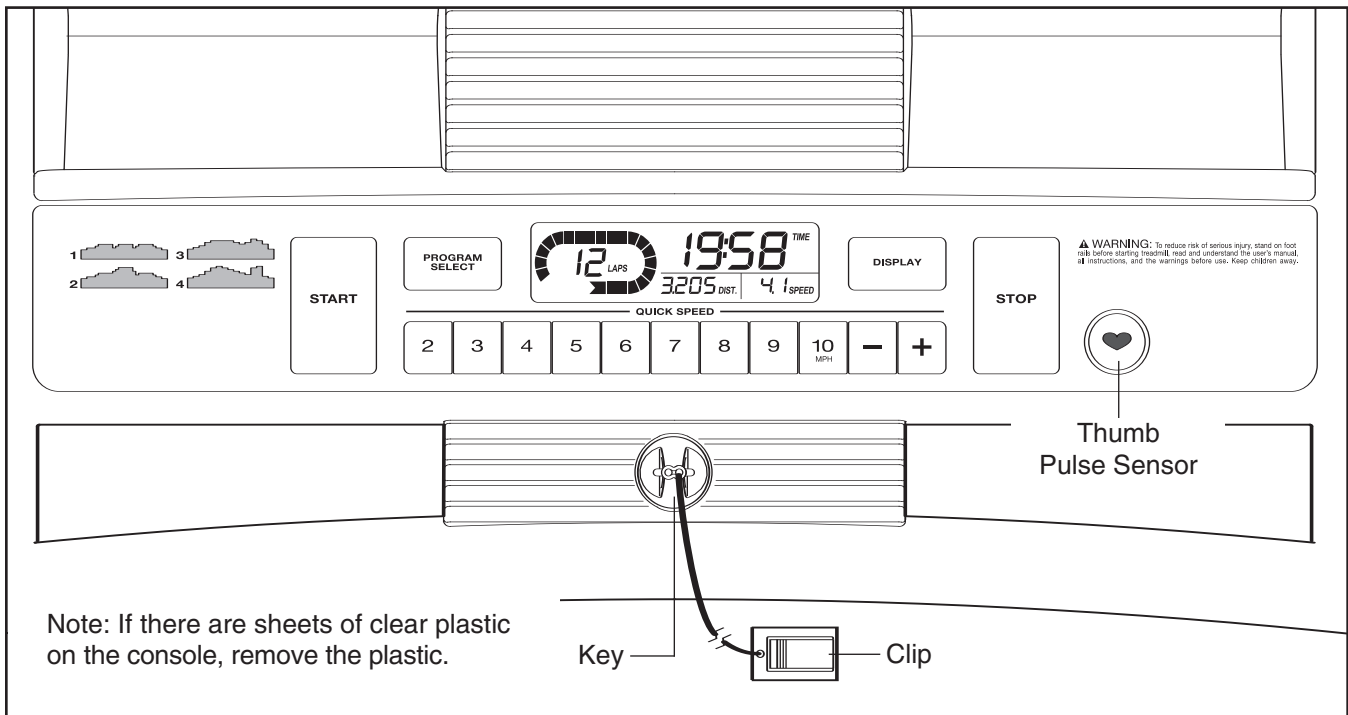

FEATURES OF THE CONSOLE

The treadmill console offers a selection of features designed to make your workouts more effective.

When you select the manual mode of the console, you can change the speed of the treadmill with the touch of a button. As you exercise, the displays will provide continuous exercise feedback. You can even measure your heart rate using the built-in pulse sensor.

The console also offers four speed programs. Each program automatically controls the speed of the treadmill as it guides you through an effective workout.

IMPORTANT: To prevent damage to the walking platform, always wear clean athletic shoes while using the treadmill. During the first few minutes that the treadmill is used, inspect the alignment of the walking belt, and center the walking belt if necessary (see page 20).

HOW TO TURN ON THE POWER

IMPORTANT: If the treadmill has been exposed to cold temperatures, allow it to warm to room temperature before turning on the power. If you do not do this, the console displays or other electrical components may become damaged.

Plug in the power cord (see page 12). Next, locate the reset/off circuit breaker on the treadmill frame near the power cord. Switch the circuit breaker to the reset position.

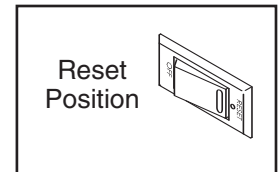

Next, stand on the foot rails of the treadmill. Find the clip attached to the key (see the drawing above) and slide the clip onto the waistband of your clothes. Then, insert the key into the console. After a moment, the displays will light. **IMPORTANT: In an emergency situation, the key can be pulled from the console, causing the walking belt to slow to a stop. Test the clip by carefully taking a few steps backward; if the key is not pulled from the console, adjust the position of the clip.**

HOW TO USE THE MANUAL MODE

1. Insert the key into the console.

See HOW TO TURN ON THE POWER on page 13.

2. Select the manual mode.

When the key is inserted, the manual mode will be selected. If you have selected a speed program, reselect the manual mode by pressing the Program Select button repeatedly until only zeros appear in the displays.



3. Start the walking belt.

To start the walking belt, press the Start button, the Quick Speed + button, or one of the numbered Quick Speed buttons.

If you press the Start button or the Quick Speed + button, the walking belt will begin to move at 1 mph. As you exercise, change the speed of the walking belt as desired by pressing the Quick Speed + and – buttons. Each time you press a button, the speed setting will change by 0.1 mph; if you hold down a button, the speed setting will change in increments of 0.5 mph. Note: After you press the buttons, it may take a moment for the walking belt to reach the selected speed setting.

If one of the numbered Quick Speed buttons is pressed, the walking belt will gradually change speed until it reaches the selected speed setting.

To stop the walking belt, press the Stop button. The time will begin to flash in one of the displays. To restart the walking belt, press the Start button or the Quick Speed + button.

4. Follow your progress with the track and the displays.

The track—The track represents a distance of 1/4 mile. As you walk or run on the treadmill, the indicators around the

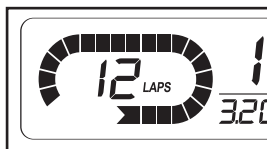

track will appear in succession until the entire track appears. The track will then disappear and the indicators will again begin to appear in succession. The center of the track will show the number of laps that you have completed.

The lower left display—

As you exercise, the lower left display can show the elapsed time and the distance that you have walked or run.



The lower right display—

The lower right display can show the speed of the walking belt and the approximate number of calories that you have burned. The display also shows your heart rate when you use the pulse sensor (see step 5 on page 15).

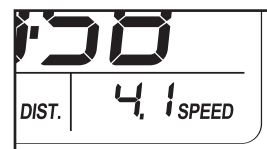

The upper display—

The upper display can show the elapsed time, the distance that you have walked or run, the speed of the walking belt, or the approximate number of calories you have burned. Press the Display button repeatedly until the upper display shows the information that you are most interested in viewing. Note: While information is shown in the upper display, the same information will not be shown in the lower displays.



To reset the displays, press the Stop button, remove the key, and then reinsert the key.

Note: The console can display speed and distance in either miles or kilometers. To see which unit of measurement is selected, first remove the key from the console. Next, hold down the Stop button, reinsert the key, wait until you hear a tone, and then release the Stop button. An “E” for English miles or an “M” for metric kilometers will appear in the upper display. Press the Speed + button to change the unit of measurement if desired. When the desired unit of measurement is selected, remove the key and then reinsert it.

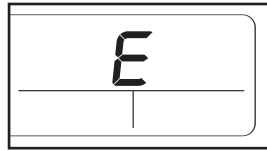

5. Measure your heart rate if desired.

To measure your heart rate, **stand on the foot rails** and place your thumb on the pulse sensor (see the drawing on page 13). **Do not press too hard, or the circulation in your thumb will be restricted and your pulse may not be detected.** When your pulse is detected, the small heart symbol in the lower right display will flash, one or two dashes will appear, and then your heart rate will be shown. **For the most accurate heart rate reading, hold your thumb on the pulse sensor for at least 15 seconds.**

If the displayed heart rate appears to be too high or too low, or if your heart rate is not displayed, lift your thumb for a few seconds, and then reposition your thumb on the pulse sensor. Remember to stand still while measuring your heart rate.

6. When you are finished exercising, remove the key from the console.

Step onto the foot rails, press the Stop button, and **adjust the incline of the treadmill to the lowest setting. The incline must be at the lowest setting or you may damage the treadmill when you fold it to the storage position.** Next, remove the key from the console and put it in a secure place.

When you are finished using the treadmill, switch the reset/off circuit breaker to the “off” position and unplug the power cord. **IMPORTANT: If you do not do this, the treadmill’s electrical components may wear prematurely.**

HOW TO USE A SPEED PROGRAM

1. Insert the key into the console.

See HOW TO TURN ON THE POWER on page 13.

2. Select one of the four speed programs.

To select a speed program, press the Program Select button repeatedly; “P- 1,” “P- 2,” “P- 3,” or “P- 4” will appear in the upper display for a few seconds to show which program is selected. The maximum speed setting of the selected program will also flash in one of the displays for a few seconds.

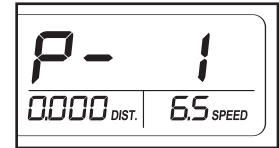

Each program consists of 30 one-minute segments. One speed setting is programmed for each segment. Note: The same speed setting may be programmed for two or more consecutive segments. The profiles on the console show how the speed of the walking belt will change during the programs.

3. Press the Start button or the Quick Speed + button to start the program.

When you press either button, the treadmill will automatically adjust to the speed setting that is programmed for the first segment of the program. Hold the handrails and begin walking.

When the first segment ends, a series of tones will sound. If a different speed setting is programmed for the second segment, the speed setting will flash in one of the displays to alert you, and then **the speed of the walking belt will change.** The program will continue until all 30 segments are completed. The walking belt will then slow to a stop.

If the speed setting is too high or too low during the program, you can manually override the setting by pressing the speed buttons. However, **when the next segment of the workout begins, the treadmill will automatically adjust to the speed setting for the next segment.**

To stop the program, press the Stop button. The time will begin to flash in one of the displays. To restart the program, press the Start button or the Speed + button. The walking belt will begin to move at 1 mph. When the next segment begins, the speed of the walking belt will change if a different speed setting is programmed for the next segment.

4. Follow your progress with the track and the displays.

See step 4 on pages 14 and 15.

5. Measure your heart rate if desired.

See step 5 on page 15.

6. When you are finished exercising, remove the key from the console.

See step 6 on page 15.

HOW TO CHANGE THE INCLINE OF THE TREADMILL

To vary the intensity of your exercise, you can change the incline of the treadmill. There are three incline levels. **Before changing the incline, remove the key and unplug the power cord.** Next, fold the treadmill to the storage position (see page 17).

To change the incline, first remove the incline pin from one of the incline legs. Adjust the incline leg to the desired position, and then fully reinsert the incline pin. Adjust the other incline leg in the same way. **CAUTION: Before using the treadmill, make sure that both incline legs are at the same height and that both incline pins are fully inserted into the incline legs.**

After you have adjusted the incline legs, lower the treadmill (see page 18).

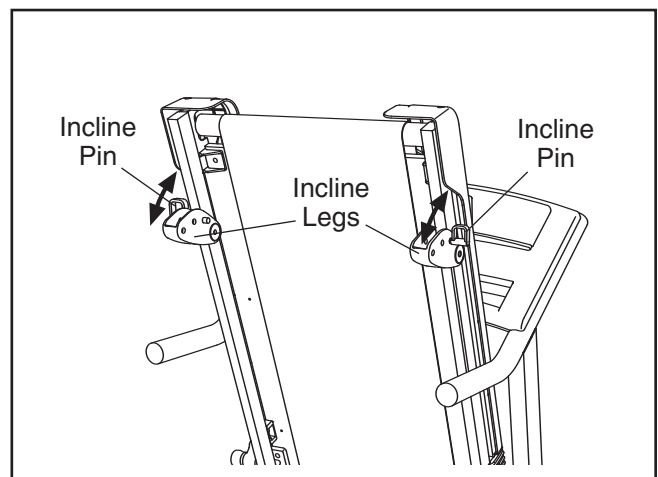

HOW TO FOLD AND MOVE THE TREADMILL

HOW TO FOLD THE TREADMILL FOR STORAGE

Before folding the treadmill, unplug the power cord.
CAUTION: You must be able to safely lift 45 lbs. (20 kg) to raise, lower, or move the treadmill.

1. Hold the metal frame firmly in the location shown by the arrow at the right. **CAUTION:** To decrease the possibility of injury, do not lift the frame by the plastic foot rails. Make sure to bend your legs and keep your back straight. As you raise the frame, make sure to lift with your legs rather than your back. Raise the frame about halfway to the vertical position.

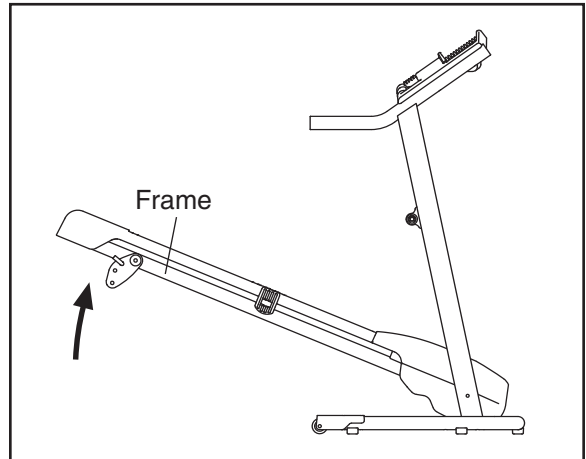

2. Move your right hand to the position shown and hold the treadmill firmly. Using your left hand, pull the latch knob to the left and hold it. Raise the frame until the catch is past the latch pin. Then, slowly release the latch knob; make sure that the catch is resting against the latch pin.

To protect the floor or carpet from damage, place a mat under the treadmill. Keep the treadmill out of direct sunlight. Do not leave the treadmill in the storage position in temperatures above 85° F (30° C).

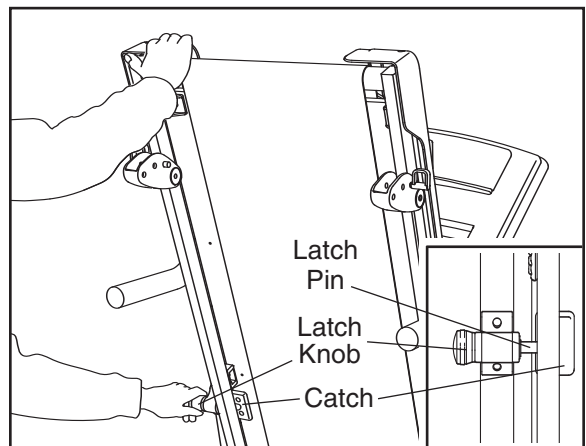

HOW TO MOVE THE TREADMILL

Before moving the treadmill, convert the treadmill to the storage position as described above. **Make sure that the catch is resting against the latch pin.**

1. Hold the handrails and place one foot against one of the wheels. **Do not pull back on the frame.**
2. Tilt the treadmill backward until it rolls freely on the wheels, and carefully move the treadmill to the desired location. **Never move the treadmill without tipping it backward. To reduce the risk of injury, use extreme caution while moving the treadmill. Do not attempt to move the treadmill over an uneven surface.**
3. Place one foot against one of the wheels, and carefully lower the treadmill until it is in the storage position.

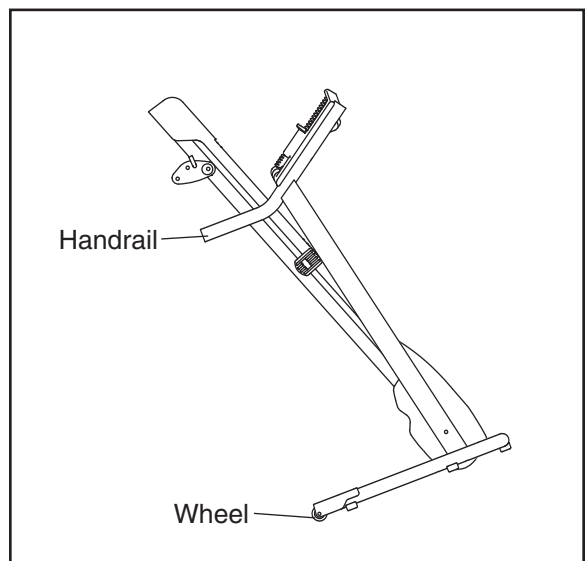

HOW TO LOWER THE TREADMILL FOR USE

1. Hold the upper end of the treadmill with your right hand as shown. Using your left hand, pull the latch knob to the left and hold it. Next, lower the frame until it is past the latch pin. Then, slowly release the latch knob.

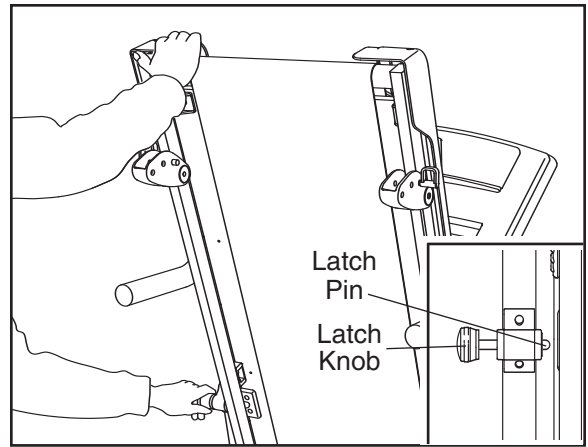

2. Hold the frame firmly with both hands, and lower it to the floor. **To decrease the possibility of injury, bend your legs and keep your back straight.**

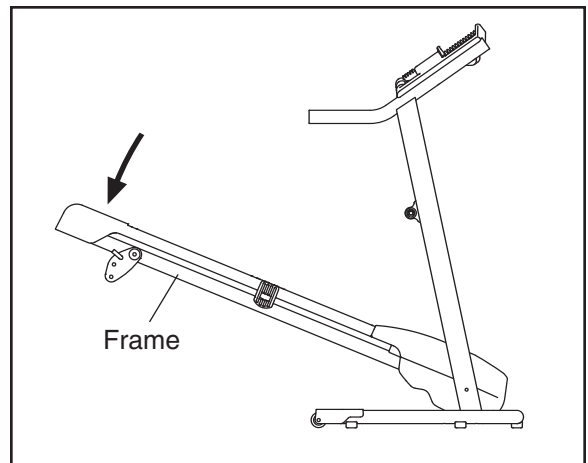

TROUBLESHOOTING

Most treadmill problems can be solved by following the steps below. Find the symptom that applies, and follow the steps listed. If further assistance is needed, please see the front cover of this manual.

PROBLEM: The power does not turn on

SOLUTION: a. Make sure that the power cord is plugged into a surge suppressor, and that the surge suppressor is plugged into a properly grounded outlet (see page 12). Use only a single-outlet surge suppressor that meets all of the specifications described on page 12. Important: The treadmill is not compatible with GFCI-equipped outlets.

b. After the power cord has been plugged in, make sure that the key is inserted into the console.

c. Check the reset/off circuit breaker located on the treadmill frame near the power cord. If the switch protrudes as shown, the circuit breaker has tripped. To reset the circuit breaker, wait for five minutes, and then press the switch back in.

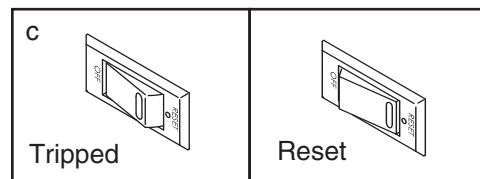

PROBLEM: The power turns off during use

SOLUTION: a. Check the reset/off circuit breaker (see the drawing above). If the circuit breaker has tripped, wait for five minutes and then press the switch back in.

b. Make sure that the power cord is plugged in.

c. Remove the key from the console. Reinsert the key into the console.

d. If the treadmill still will not run, please see the front cover of this manual.

PROBLEM: The displays of the console do not function properly

SOLUTION: a. Remove the key from the console and **UNPLUG THE POWER CORD**. Remove the three indicated Hood Screws (20) and two Foot Rail Screws (25). Then, carefully remove the Hood (65).

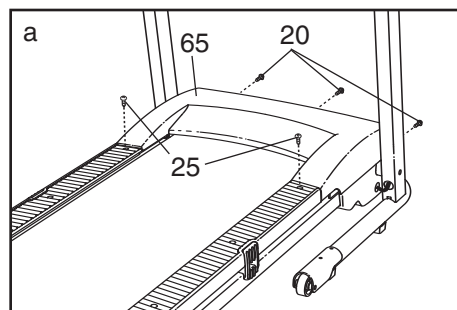

Locate the Reed Switch (89) and the Magnet (62) on the left side of the Pulley (71). Turn the Pulley until the Magnet is aligned with the Reed Switch. **Make sure that the gap between the Magnet and the Reed Switch is about 1/8 in. (3 mm)**. If necessary, loosen the Reed Switch Screw (3), move the Reed Switch slightly, and then retighten the Screw. Reattach the Hood (not shown), and run the treadmill for a few minutes to check for a correct speed reading.

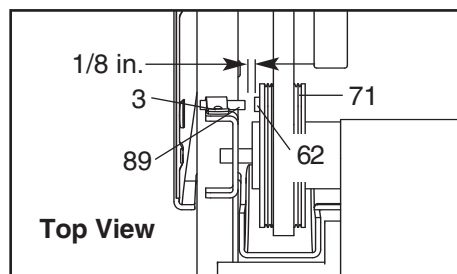

PROBLEM: The walking belt slows when walked on

SOLUTION: a. Use only a single-outlet surge suppressor that meets all of the specifications described on page 12.

b. If the walking belt is overtightened, treadmill performance may decrease and the walking belt may become damaged. Remove the key and **UNPLUG THE POWER CORD**. Using the hex key, turn both rear roller bolts counterclockwise, 1/4 of a turn. When the walking belt is properly tightened, you should be able to lift each edge of the walking belt 2 to 3 in. (5 to 7 cm) off the walking platform. Be careful to keep the walking belt centered. Then, plug in the power cord, insert the key, and run the treadmill for a few minutes. Repeat until the walking belt is properly tightened.

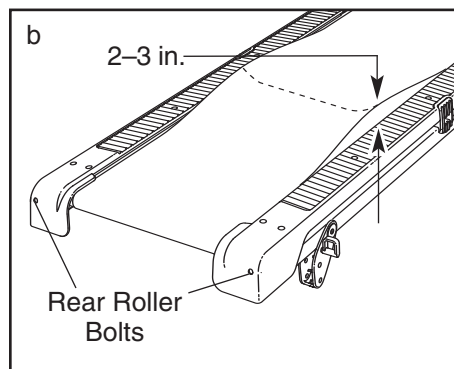

c. If the walking belt still slows when walked on, see the front cover of this manual.

PROBLEM: The walking belt is off-center or slips when walked on

SOLUTION: a. **If the walking belt has shifted to the left**, first remove the key and **UNPLUG THE POWER CORD**. Using the hex key, turn the left rear roller bolt clockwise 1/2 of a turn. Be careful not to overtighten the walking belt. **If the walking belt has shifted to the right**, turn the left rear roller bolt counterclockwise 1/2 of a turn. Then, plug in the power cord, insert the key, and run the treadmill for a few minutes. Repeat until the walking belt is centered.

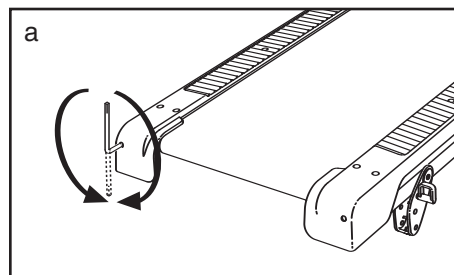

b. **If the walking belt slips when walked on**, first remove the key and **UNPLUG THE POWER CORD**. Using the hex key, turn both rear roller bolts clockwise, 1/4 of a turn. When the walking belt is correctly tightened, you should be able to lift each edge of the walking belt 2 to 3 in. (5 to 7 cm) off the walking platform. Be careful to keep the walking belt centered. Then, plug in the power cord, insert the key, and carefully walk on the treadmill for a few minutes. Repeat until the walking belt is properly tightened.

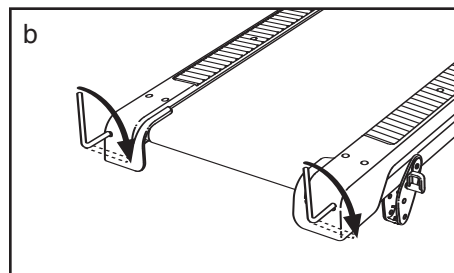

EXERCISE GUIDELINES

⚠️ WARNING: Before beginning this or any exercise program, consult your physician. This is especially important for persons over the age of 35 or persons with pre-existing health problems.

The pulse sensor is not a medical device. Various factors may affect the accuracy of heart rate readings. The pulse sensor is intended only as an exercise aid in determining heart rate trends in general.

These guidelines will help you to plan your exercise program. For detailed exercise information, obtain a reputable book or consult your physician. Remember, proper nutrition and adequate rest are essential for successful results.

EXERCISE INTENSITY

Whether your goal is to burn fat or to strengthen your cardiovascular system, exercising at the proper intensity is the key to achieving results. You can use your heart rate as a guide to find the proper intensity level. The chart below shows recommended heart rates for fat burning and aerobic exercise.

165	155	145	140	130	125	115	♥♥
145	138	130	125	118	110	103	♥
125	120	115	110	105	95	90	♥
<hr/>							
20	30	40	50	60	70	80	

To find the proper intensity level, find your age at the bottom of the chart (ages are rounded off to the nearest ten years). The three numbers listed above your age define your “training zone.” The lowest number is the heart rate for fat burning, the middle number is the heart rate for maximum fat burning, and the highest number is the heart rate for aerobic exercise.

Burning Fat—To burn fat effectively, you must exercise at a low intensity level for a sustained period of time. During the first few minutes of exercise, your body uses *carbohydrate calories* for energy. Only after the first few minutes of exercise does your body begin to use stored *fat calories* for energy. If your goal is to burn fat, adjust the intensity of your exercise until your heart rate is near the lowest number in your training zone. For maximum fat burning, exercise with your heart rate near the middle number in your training zone.

Aerobic Exercise—If your goal is to strengthen your cardiovascular system, you must perform aerobic exercise, which is activity that requires large amounts of oxygen for prolonged periods of time. For aerobic exercise, adjust the intensity of your exercise until your heart rate is near the highest number in your training zone.

WORKOUT GUIDELINES

Warming up—Start with 5 to 10 minutes of stretching and light exercise. A warm-up increases your body temperature, heart rate, and circulation in preparation for exercise.

Training Zone Exercise—Exercise for 20 to 30 minutes with your heart rate in your training zone. (During the first few weeks of your exercise program, do not keep your heart rate in your training zone for longer than 20 minutes.) Breathe regularly and deeply as you exercise—never hold your breath.

Cooling down—Finish with 5 to 10 minutes of stretching. Stretching increases the flexibility of your muscles and helps to prevent post-exercise problems.

EXERCISE FREQUENCY

To maintain or improve your condition, complete three workouts each week, with at least one day of rest between workouts. After a few months of regular exercise, you may complete up to five workouts each week, if desired. Remember, the key to success is to make exercise a regular and enjoyable part of your everyday life.

SUGGESTED STRETCHES

The correct form for several basic stretches is shown at the right. Move slowly as you stretch—never bounce.

1. Toe Touch Stretch

Stand with your knees bent slightly and slowly bend forward from your hips. Allow your back and shoulders to relax as you reach down toward your toes as far as possible. Hold for 15 counts, then relax. Repeat 3 times. Stretches: Hamstrings, back of knees and back.

2. Hamstring Stretch

Sit with one leg extended. Bring the sole of the opposite foot toward you and rest it against the inner thigh of your extended leg. Reach toward your toes as far as possible. Hold for 15 counts, then relax. Repeat 3 times for each leg. Stretches: Hamstrings, lower back and groin.

3. Calf/Achilles Stretch

With one leg in front of the other, reach forward and place your hands against a wall. Keep your back leg straight and your back foot flat on the floor. Bend your front leg, lean forward and move your hips toward the wall. Hold for 15 counts, then relax. Repeat 3 times for each leg. To cause further stretching of the achilles tendons, bend your back leg as well. Stretches: Calves, achilles tendons and ankles.

4. Quadriceps Stretch

With one hand against a wall for balance, reach back and grasp one foot with your other hand. Bring your heel as close to your buttocks as possible. Hold for 15 counts, then relax. Repeat 3 times for each leg. Stretches: Quadriceps and hip muscles.

5. Inner Thigh Stretch

Sit with the soles of your feet together and your knees outward. Pull your feet toward your groin area as far as possible. Hold for 15 counts, then relax. Repeat 3 times. Stretches: Quadriceps and hip muscles.

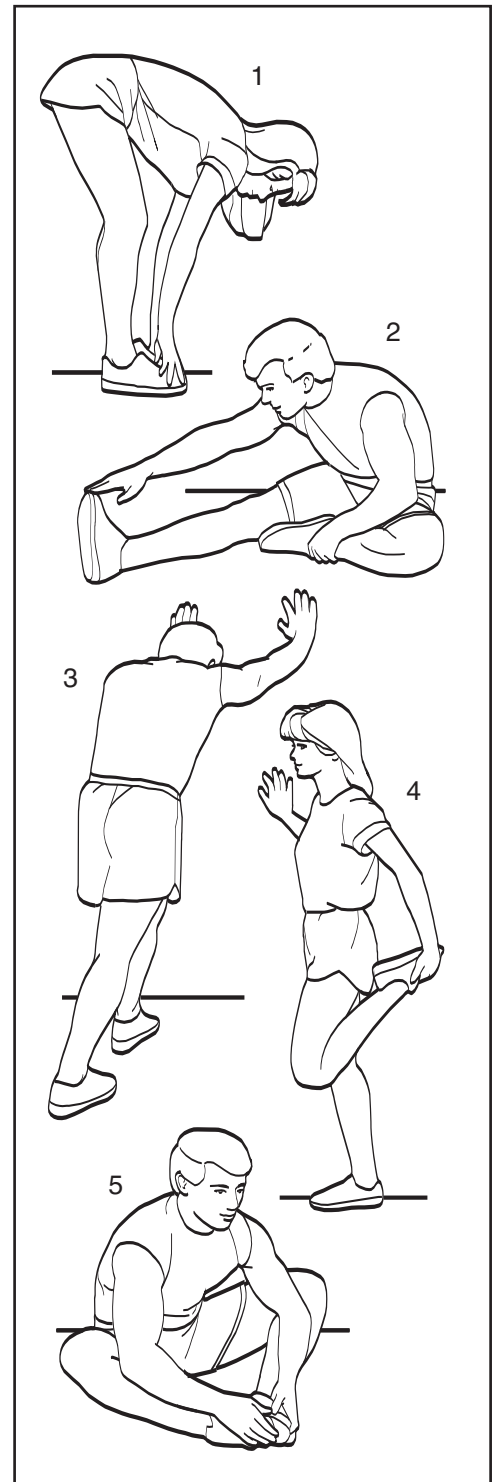

PART LIST—Model No. WCTL29607.0

R0807A

To locate the parts listed below, see the EXPLODED DRAWING near the end of this manual.

Key No.	Qty.	Description	Key No.	Qty.	Description
1	2	M10 x 110mm Bolt	55	1	Rear Roller
2	4	M10 x 58mm Bolt	56	1	Motor Belt
3	2	Wire Tie Screw/Reed Switch Screw	57	1	Electronics Bracket
4	16	16mm Screw	58	2	18mm Screw
5	6	M8 Star Washer	59	1	Motor Bracket
6	1	English Warning Decal	60	1	Left Rear Roller Bracket
7	2	M5 Star Washer	61	1	Right Rear Roller Bracket
8	6	M8 x 15mm Bolt	62	1	Magnet
9	2	M10 Star Washer	63	6	Base Pad
10	10	19mm Screw	64	1	Catch
11	2	Frame Spacer	65	1	Hood
12	1	Console Back	66	1	Belly Pan
13	4	M6 x 58mm Bolt	67	1	Left Foot Rail
14	2	M10 Flat Washer	68	1	Right Foot Rail
15	1	Key/Clip	69	4	Wheel Spacer
16	2	Nut	70	2	Wheel
17	1	6mm Hex Key	71	1	Front Roller/Pulley
18	1	4mm Hex Key	72	4	M8 Flat Washer
19	4	Roller Bracket Screw/Platform Screw	73	1	Access Door
20	3	Hood Screw	74	2	Frame Endcap
21	8	M4.2 x 13mm Screw	75	4	Long Foot Rail Screw
22	1	Left Handrail	76	1	Walking Belt
23	1	Upright Grommet	77	4	Handrail Endcap
24	1	Latch Pin Assembly	78	2	Platform Cushion
25	6	Foot Rail Screw	79	1	Drive Motor
26	6	19mm Tek Screw	80	1	Wire Tie
27	2	Walking Platform Bolt	81	2	8" Tie
28	4	Belt Guide Screw	82	2	M8 x 52mm Bolt
29	2	Rear Roller Adj. Bolt	83	1	Reed Switch Clip
30	2	Motor Bolt	84	1	Motor Pivot Nut
31	1	Motor Pivot Bolt	85	2	16mm Screw
32	4	M6 Flat Washer	86	1	Walking Platform
33	1	Right Handrail	87	1	Controller
34	2	Motor Tension Bolt	88	1	Console Crossbar
35	2	Wheel Bolt	89	1	Reed Switch
36	2	Rear Roller Star Washer	90	1	Power Cord
37	1	Reset/Off Circuit Breaker	91	1	Console
38	2	Motor Star Washer	92	1	Releasable Tie
39	1	Wire Harness	93	2	Belt Guide
40	2	Incline Pin	94	1	5mm Hex Key
41	4	Belly Pan Screw	95	2	Incline Leg
42	4	Electronics Star Washer	96	2	Insert Nut
43	4	M6 Nut	97	2	Front Roller Washer
44	6	Motor Tension Nut/Platform Nut	98	1	Filter Wire
45	2	Wheel Housing	99	1	Power Cord Grommet
46	2	M8 Nut	100	6	Cage Nut
47	3	Hood Clip	101	2	Rear Isolator
48	1	Latch Housing	102	1	French Warning Decal
49	1	Belly Pan Grommet	*	–	10" Blue Wire, 2F
50	2	Isolator Fastener	*	–	4" Blue Wire, 2F
51	1	Frame	*	–	4" Red Wire, M/F
52	1	Base	*	–	User's Manual
53	1	Left Upright			
54	1	Right Upright			

*These parts are not illustrated.

Specifications are subject to change without notice.

EXPLODED DRAWING A—Model No. WCTL29607.0

R0807A

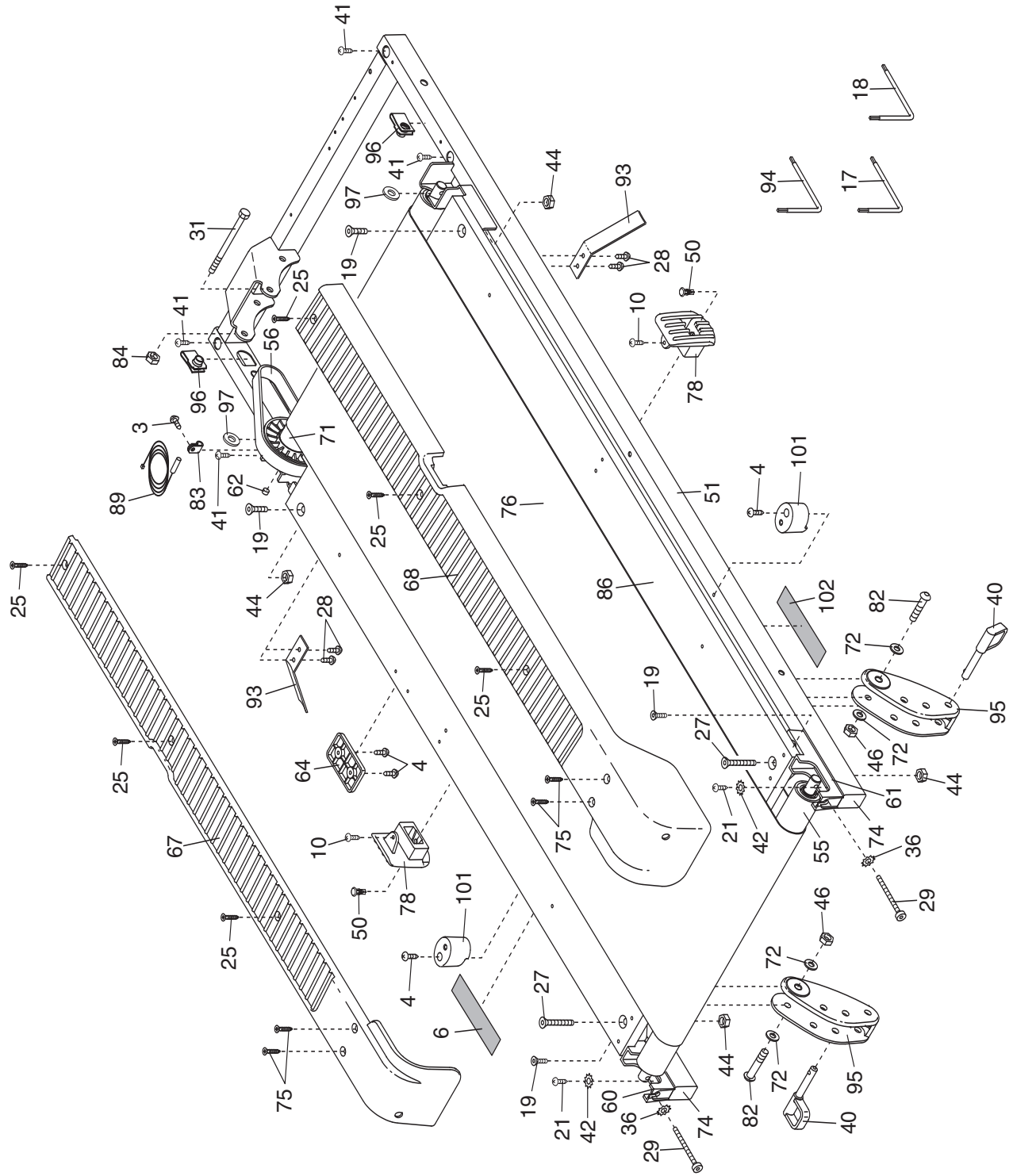

EXPLODED DRAWING B—Model No. WCTL29607.0

R0807A

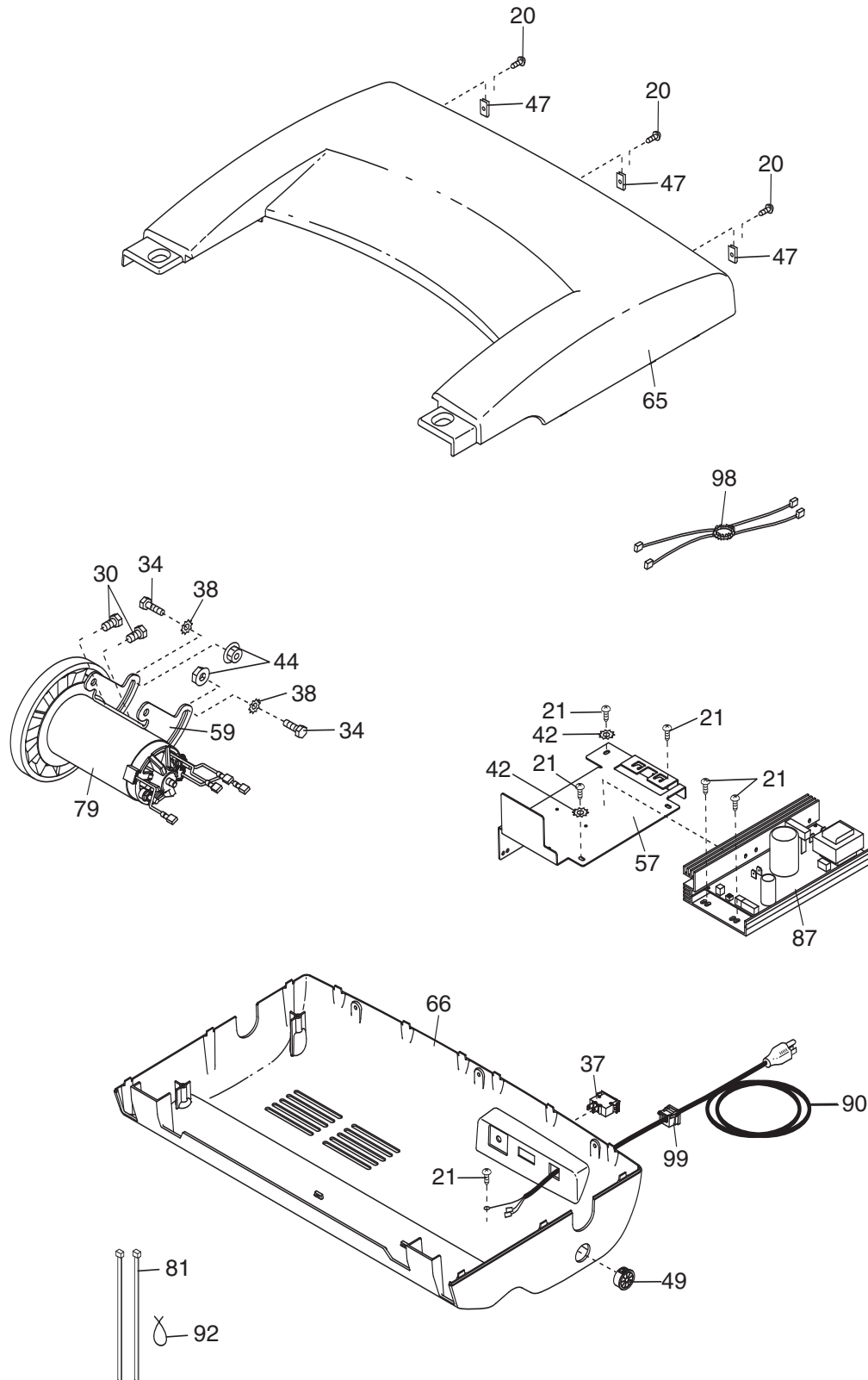

EXPLODED DRAWING C—Model No. WCTL29607.0

R0807A

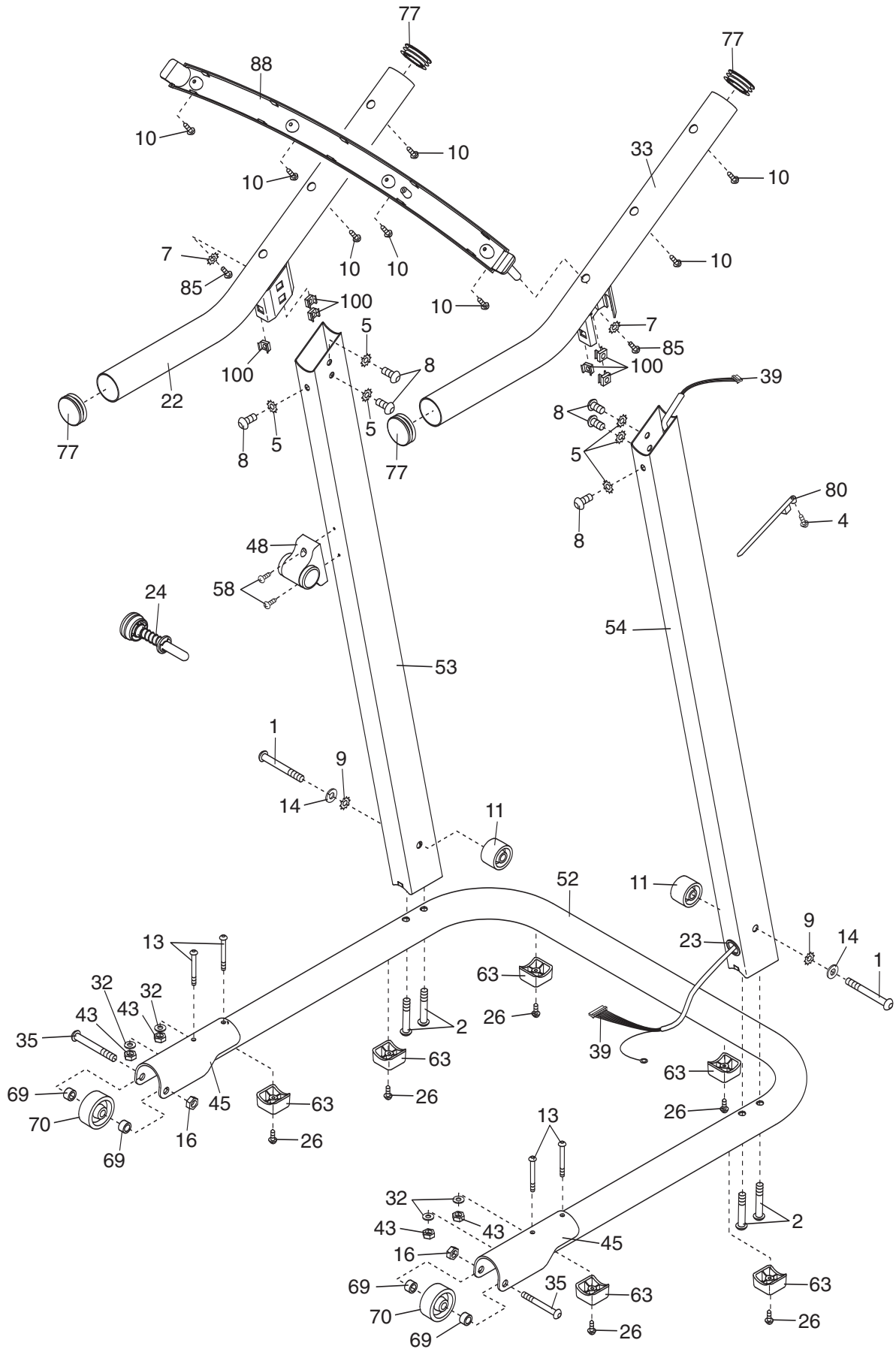

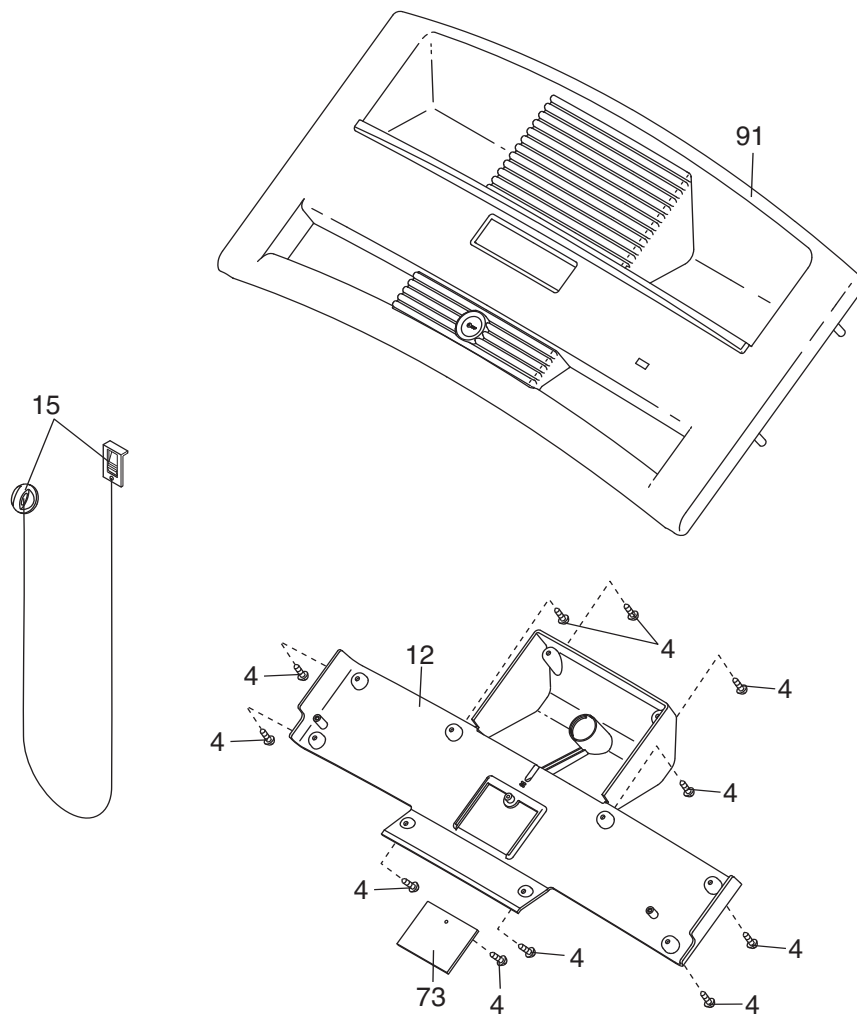

ORDERING REPLACEMENT PARTS

To order replacement parts, please see the front cover of this manual. To help us assist you, be prepared to provide the following information when calling:

- the model number and serial number of the product (see the front cover of this manual)
- the name of the product (see the front cover of this manual)
- the key number and description of the replacement part(s) (see the PART LIST and the EXPLODED DRAWING near the end of this manual)

LIMITED WARRANTY

ICON OF CANADA, INC. (ICON) warrants this product to be free from defects in workmanship and material, under normal use and service conditions. The drive motor is warranted for one (1) year after the date of purchase. Parts are warranted for one (1) year after the date of purchase. Labor is warranted for ninety (90) days after the date of purchase.

This warranty extends only to the original purchaser. ICON's obligation under this warranty is limited to replacing or repairing, at ICON's option, the product through one of its authorized service centers. All repairs for which warranty claims are made must be pre-authorized by ICON. This warranty does not extend to any product or damage to a product caused by or attributable to freight damage, abuse, misuse, improper or abnormal usage or repairs not provided by an ICON authorized service center, to products used for commercial or rental purposes, or to products used as store display models. No other warranty beyond that specifically set forth above is authorized by ICON.

ICON is not responsible or liable for indirect, special or consequential damages arising out of or in connection with the use or performance of the product or damages with respect to any economic loss, loss of property, loss of revenues or profits, loss of enjoyment or use, costs of removal, installation or other consequential damages of whatsoever nature. Some provinces do not allow the exclusion or limitation of incidental or consequential damages. Accordingly, the above limitation may not apply to you. The warranty extended hereunder is in lieu of any and all other warranties and any implied warranties of merchantability or fitness for a particular purpose is limited in its scope and duration to the terms set forth herein. Some provinces do not allow limitations on how long an implied warranty lasts. Accordingly, the above limitation may not apply to you.

This warranty gives you specific legal rights. You may also have other rights which vary from province to province or so specified by the retailer of your equipment.

ICON OF CANADA, INC., 900 de l'Industrie, St. Jérôme, QC J7Y 4B8