

Missing parts? Call 1-800-573-2860  
Pièces manquantes? Appeler le 1-800-573-2860  
¿Faltan piezas? Llame al 1-800-573-2860

Desk Parts

- 28 Glass desk top (1)
- 29 Rear frame (1)
- 30 Front frame (1)
- 31 Rear corner braces (2)
- 32 Front corner braces (2)
- 33 Rear center brace (1)
- 34 Screws M6×10 mm (4)
- 35 Screws M6×12 mm (20)
- 36 S-shaped hex wrench (1)

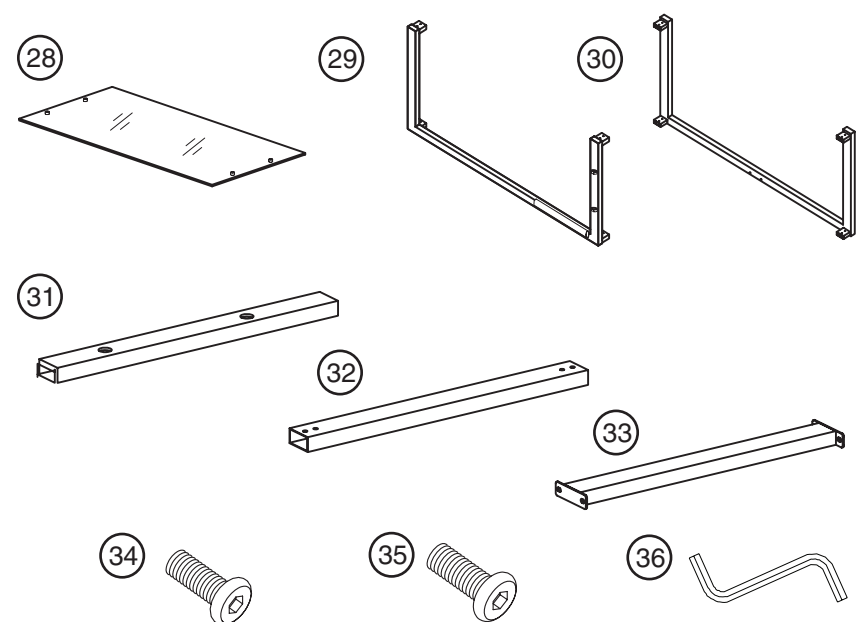

Éléments pour le bureau

- 28 Dessus en verre du bureau (1)
- 29 Structure arrière (1)
- 30 Structure avant (1)
- 31 Entretoises de l'angle arrière (2)
- 32 Entretoises de l'angle avant (2)
- 33 Entretoise arrière centrale (1)
- 34 Vis M6 × 10 mm (4)
- 35 Vis M6 × 12 mm (20)
- 36 Clé hexagonale en S (1)

Partes del escritorio

- 28 Panel superior de vidrio del escritorio (1)
- 29 Bastidor posterior (1)
- 30 Bastidor frontal (1)
- 31 Soportes para los ángulos posteriores (2)
- 32 Soportes para los ángulos frontales (2)
- 33 Soporte posterior central (1)
- 34 Tornillos M6 × 10 mm (4)
- 35 Tornillos M6 × 12 mm (20)
- 36 Llave hexagonal en forma de S (1)

Cabinet Parts

- 1 Glass top (1)
- 2 Front frame (1)
- 3 Upper braces (2)
- 4 Lower braces (2)
- 5 Back frame (1)
- 6 Left side (1)
- 7 Right side (1)
- 8 File drawer left side (1)
- 9 File drawer back (1)
- 10 File drawer right side (1)
- 11 Drawer bottoms (3)
- 12 File drawer front (1)
- 13 Utility drawers left side (2)
- 14 Utility drawers back (2)
- 15 Utility drawers right side (2)
- 16 Utility drawers front (2)
- 17 File rail (2)
- 18 Bolts (16)
- 19 Drawer handle (3)
- 20 Front casters (2)
- 21 Back casters (2)
- 22 Flat-tipped screws 5/32" × 12 mm (6)
- 23 Screws M6×12 mm (16)
- 24 Screws M6×15 mm (2)
- 25 Sharp-tipped Screws M4×12 mm (12)
- 26 Wrench (1)
- 27 L-shaped hex wrench (1)

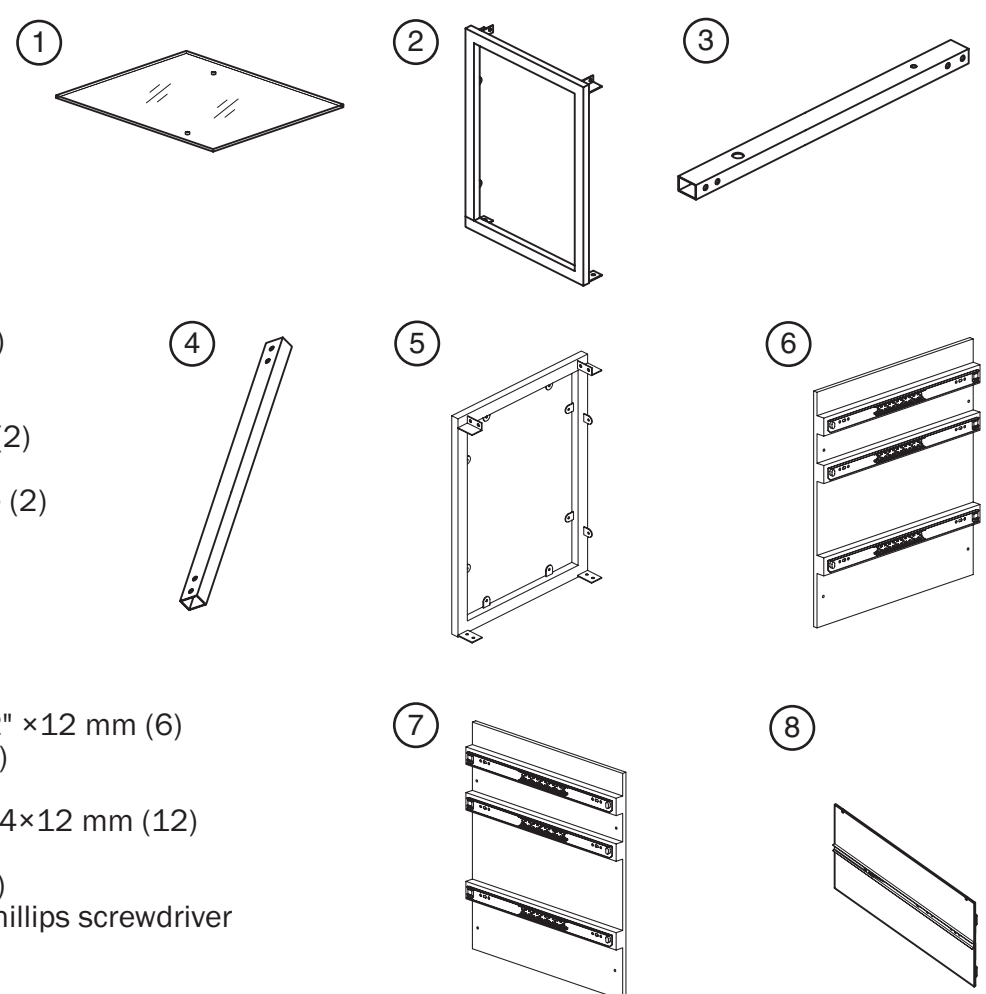

Additional Tools required: Phillips screwdriver

Éléments du classeur mobile

- 1 Dessus en verre (1)
- 2 Structure avant (1)
- 3 Entretoises supérieures (2)
- 4 Entretoises inférieures (2)
- 5 Structure arrière (1)
- 6 Côté gauche (1)
- 7 Côté droit (1)
- 8 Côté gauche du tiroir à dossiers (1)
- 9 Arrière du tiroir à dossiers (1)
- 10 Côté droit du tiroir à dossiers (1)
- 11 Fonds du tiroir (3)
- 12 Avant du tiroir à dossiers (1)
- 13 Côté gauche du tiroir de rangement (2)
- 14 Arrière du tiroir de rangement (2)
- 15 Côté droit du tiroir de rangement (2)
- 16 Avant du tiroir de rangement (2)
- 17 Supports dossiers suspendus (2)
- 18 Vis (16)
- 19 Poignée du tiroir (3)
- 20 Roulettes avant (2)
- 21 Roulettes arrière (2)
- 22 Vis à bout plat 5/32 po × 12 mm (6)
- 23 Vis M6 × 12 mm (16)
- 24 Vis M6 × 15 mm (2)
- 25 Vis à bout pointu M4 × 12 mm (12)
- 26 Clé (1)
- 27 Clé hexagonale en L (1)

Outils supplémentaires nécessaires : un tournevis cruciforme

Partes del archivero

- 1 Panel superior de vidrio (1)
- 2 Bastidor frontal (1)
- 3 Soportes superiores (2)
- 4 Soportes inferiores (2)
- 5 Bastidor posterior (1)
- 6 Lado izquierdo (1)
- 7 Lado derecho (1)
- 8 Lado izquierdo del archivero (1)
- 9 Parte posterior del archivero (1)
- 10 Lado derecho del archivero (1)
- 11 Paneles inferiores de las gavetas (3)
- 12 Parte frontal de la gaveta para carpetas colgantes (1)
- 13 Lado izquierdo de las gavetas de uso general (2)
- 14 Panel posterior de las gavetas de uso general (2)
- 15 Panel lateral derecho de las gavetas de uso general (2)
- 16 Panel frontal de las gavetas de uso general (2)
- 17 Riel para las carpetas colgantes (2)
- 18 Pernos (16)
- 19 Agarradera de la gaveta (3)
- 20 Ruedas frontales (2)
- 21 Ruedas posteriores (2)
- 22 Tornillos de punta plana 5/32 pulg. × 12 mm (6)
- 23 Tornillos M6 × 12 mm (16)
- 24 Tornillos M6 × 15 mm (2)
- 25 Tornillos con punta afilada M4×12 mm (12)
- 26 Llave (1)
- 27 Llave hexagonal con forma de L (1)

Herramientas adicionales requeridas: Un destornillador Phillips

## File Cabinet Assembly Montage du classeur mobile Ensamblaje del gabinete del archivero

### 1 Assemble frame

Monter la structure  
Arme el bastidor

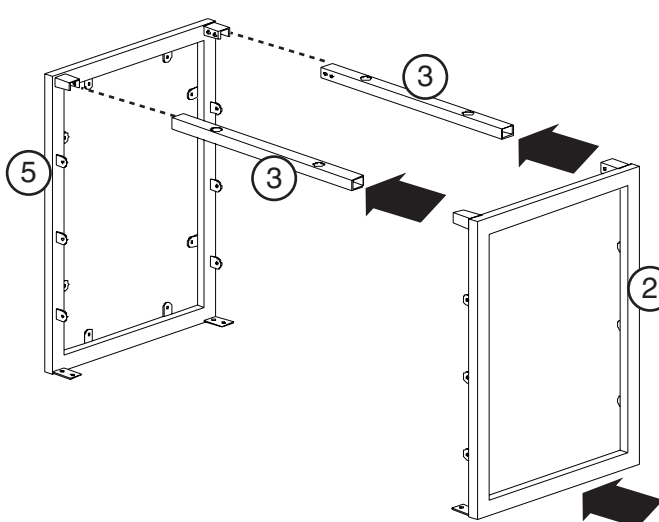

23 Screws M6×12 mm (16)  
Vis M6 × 12 mm (16)  
Tornillos M6 × 12 mm (16)

27 L shaped wrench (1)  
Clé hexagonale en L (1)  
Llave hexagonal con forma de L (1)

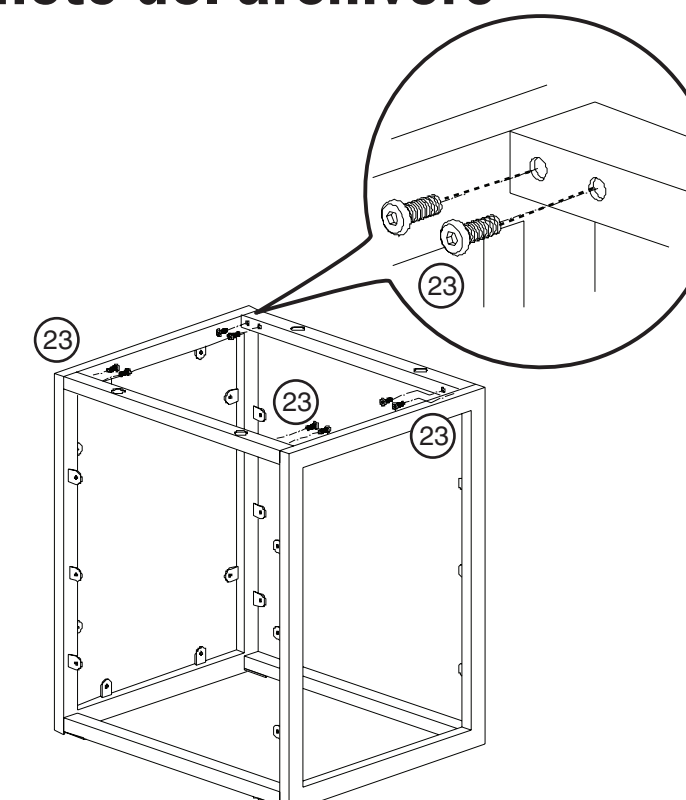
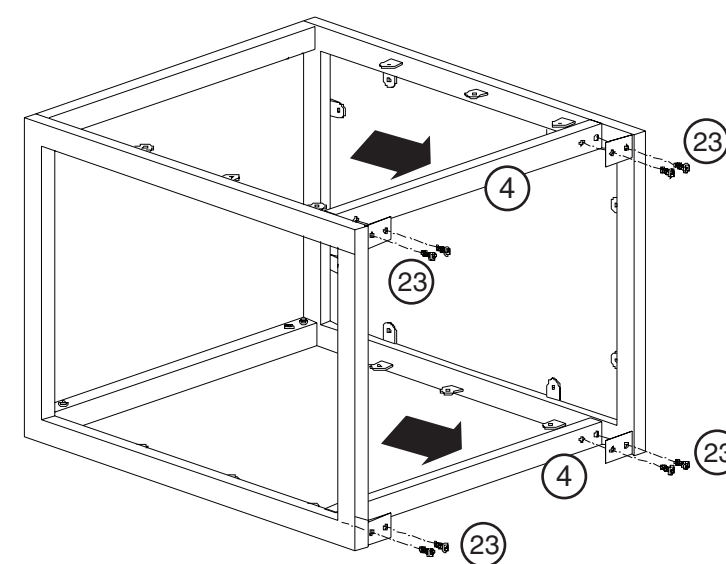

### 2 Assemble side panels

Fixer les panneaux latéraux  
Ensamble los paneles laterales

25 Sharp-tipped Screws  
M4×12 mm (12)  
Vis à bout pointu M4 × 12 mm (12)  
Tornillos con punta afilada M4×12 mm (12)

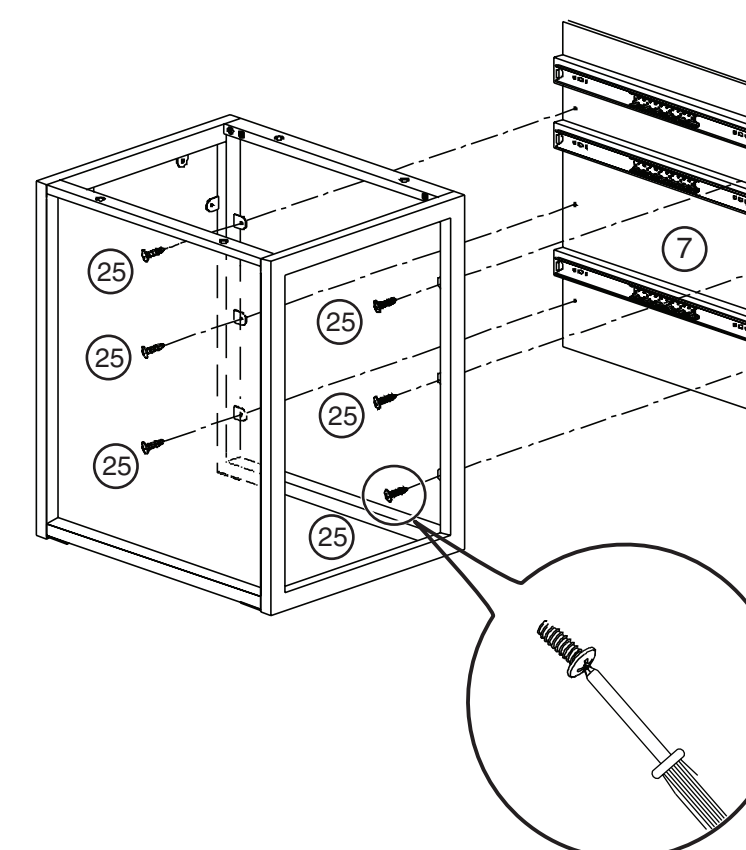
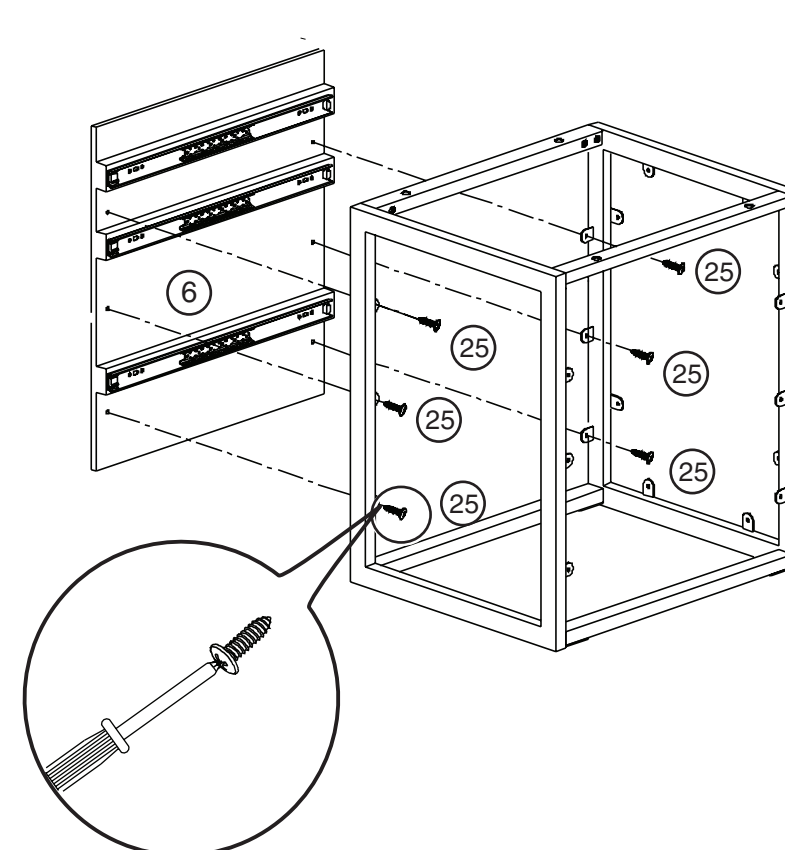

### 3 Attach file cabinet casters

Fixer les roulettes du classeur mobile  
Fije las ruedas al archivero

20 Front casters (2)  
Roulettes avant (2)  
Ruedas frontales (2)

21 Back casters (2)  
Roulettes arrière (2)  
Ruedas posteriores (2)

26 Wrench (1)  
Clé (1)  
Llave (1)

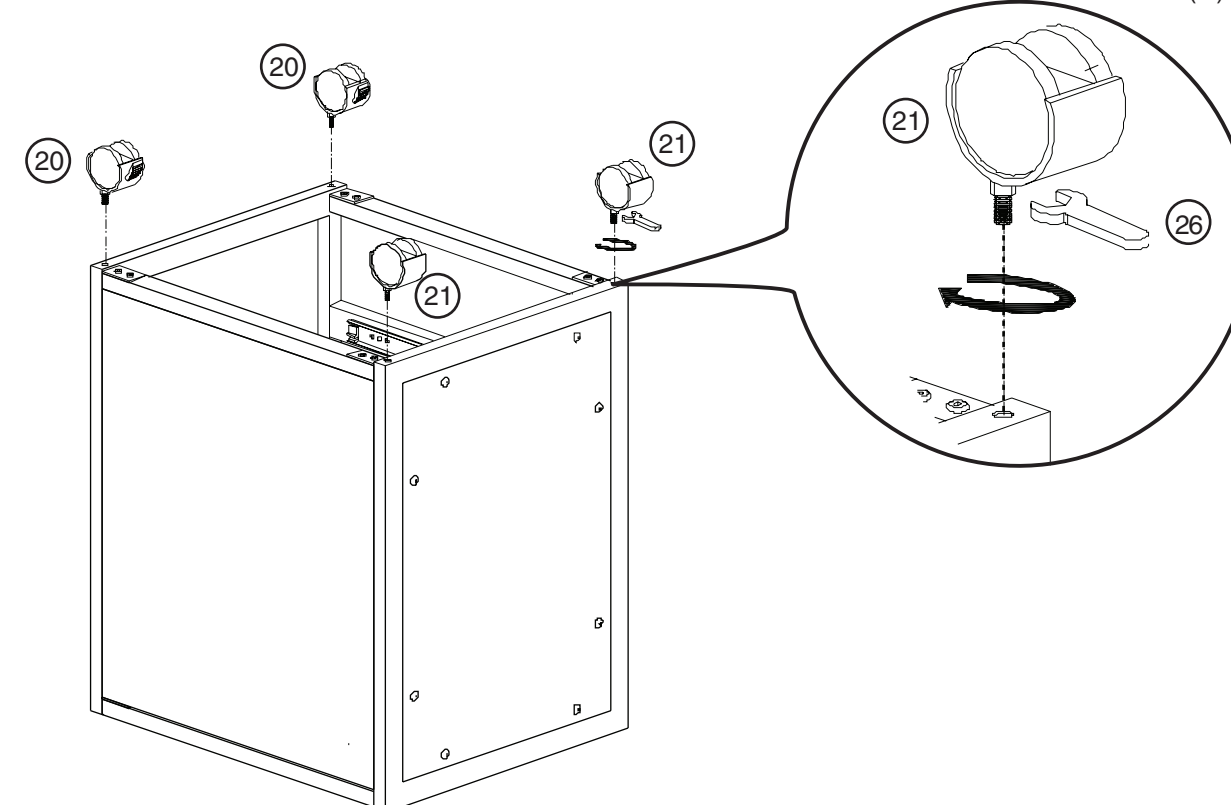

(Continue on backside)  
(suite au verso)  
(ver al reverso)

init™

ASSEMBLY INSTRUCTIONS  
INSTRUCTIONS D'ASSEMBLAGE  
INSTRUCCIONES DE ENSAMBLAJE

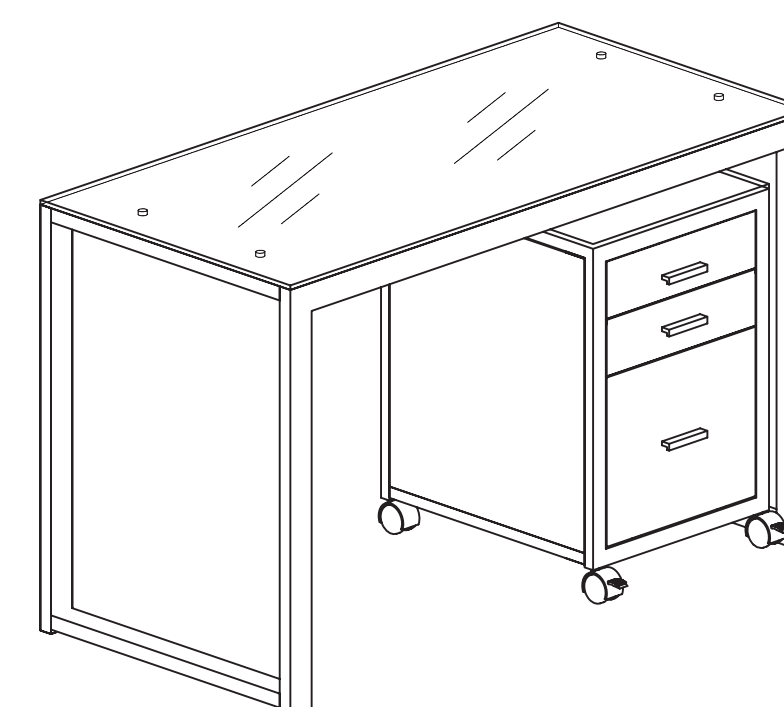

**NT-C3103**  
48" Steel/Glass Desk  
with File Cabinet

Bureau en acier et verre de  
48 po avec classeur mobile  
Escritorio de acero y vidrio  
de 48" con archivero



**4 Attach top glass**  
 Fixation du dessus en verre  
 Fije el panel de vidrio superior

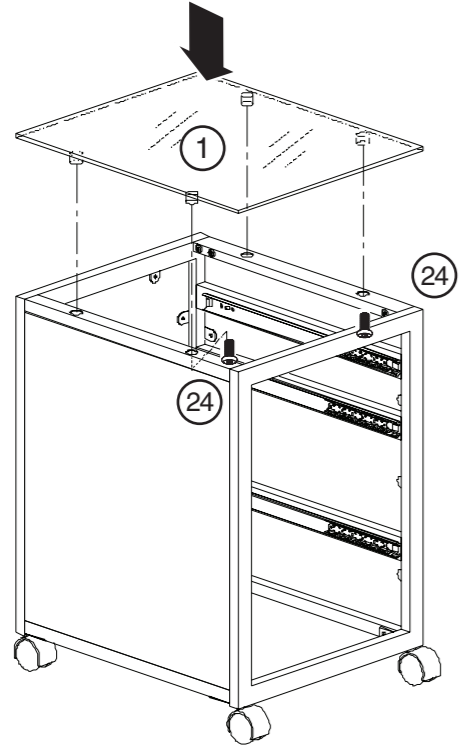

- (24) Screws M6×15 mm (2)  
 Vis M6 × 15 mm (2)  
 Tornillos M6 × 15 mm (2)
- (27) L shaped wrench (1)  
 Clé hexagonale en L (1)  
 Llave hexagonal con forma de L (1)

**5 Assemble bottom utility drawer**  
 Monter le dessous du tiroir de rangement  
 Ensamble la gaveta de uso general inferior

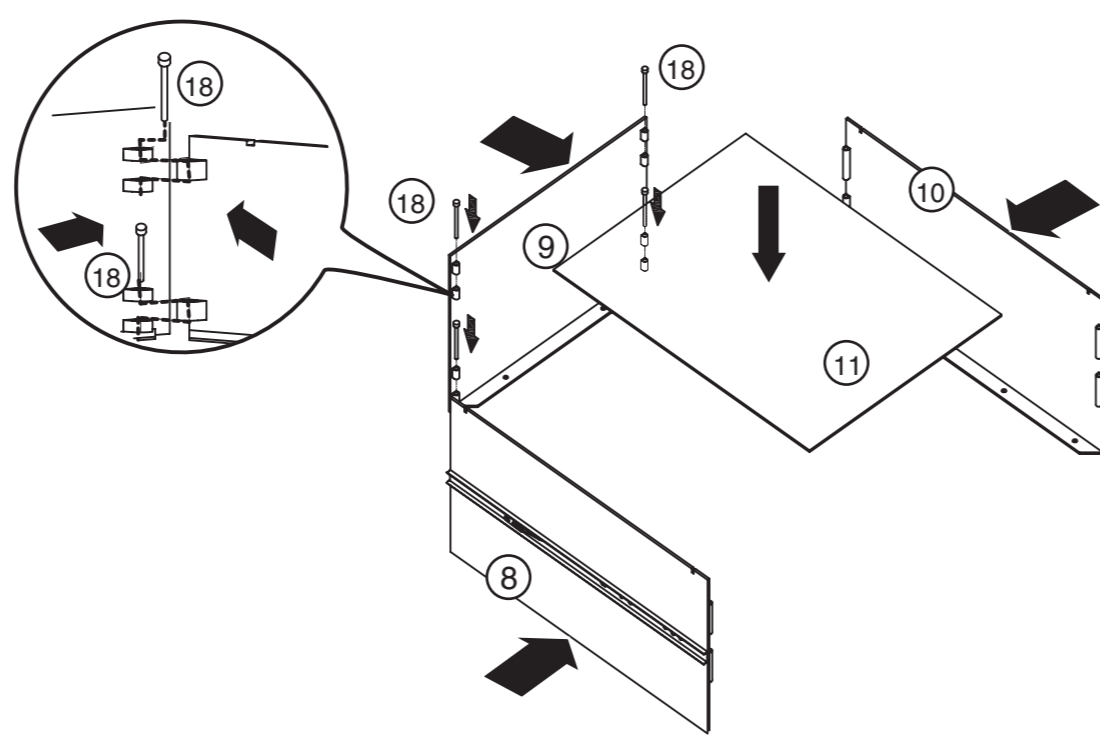

- (18) Bolts (8)  
 Vis (8)  
 Pernos (8)
- (19) Drawer handles (1)  
 Poignée du tiroir (1)  
 Agarradera de la gaveta (1)
- (22) Flat-tipped screws  
 5/32" × 12 mm (2)  
 Vis à bout plat 5/32 po × 12 mm (2)  
 Tornillos de punta plana 5/32 pulg. × 12 mm (2)
- (27) L shaped wrench (1)  
 Clé hexagonale en L (1)  
 Llave hexagonal con forma de L (1)

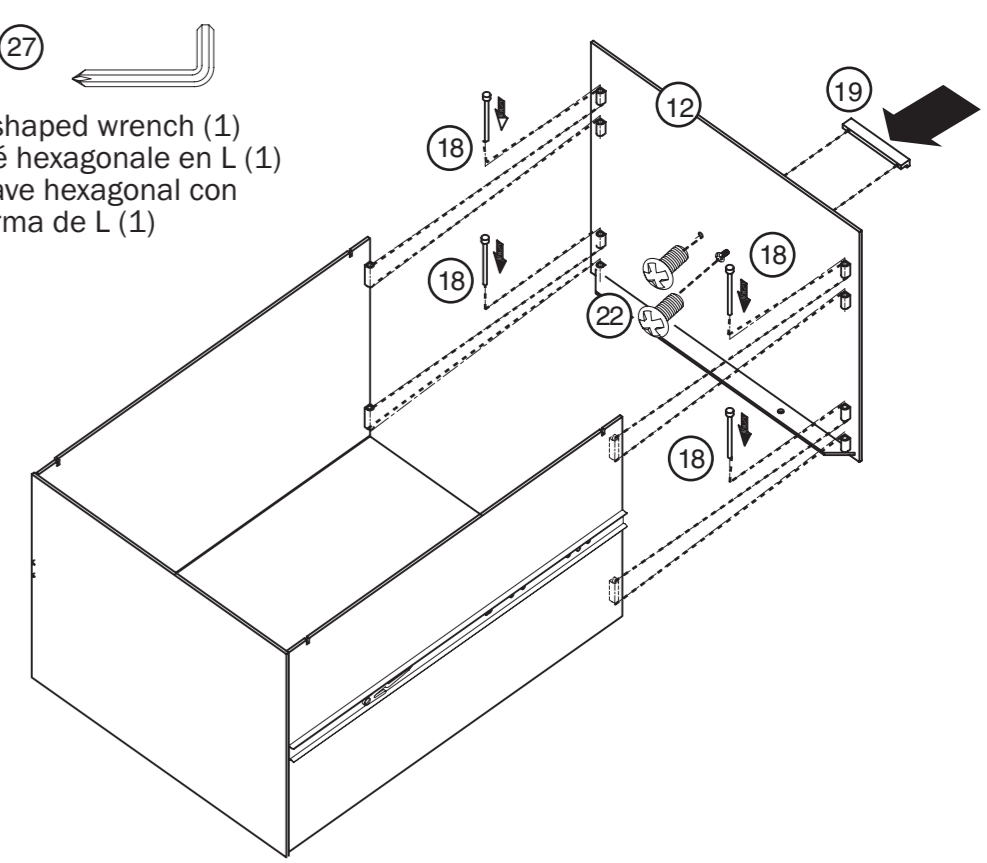

**6 Attach file rails**  
 Fixer les supports de dossiers suspendus  
 Instale los rieles para las carpetas colgantes

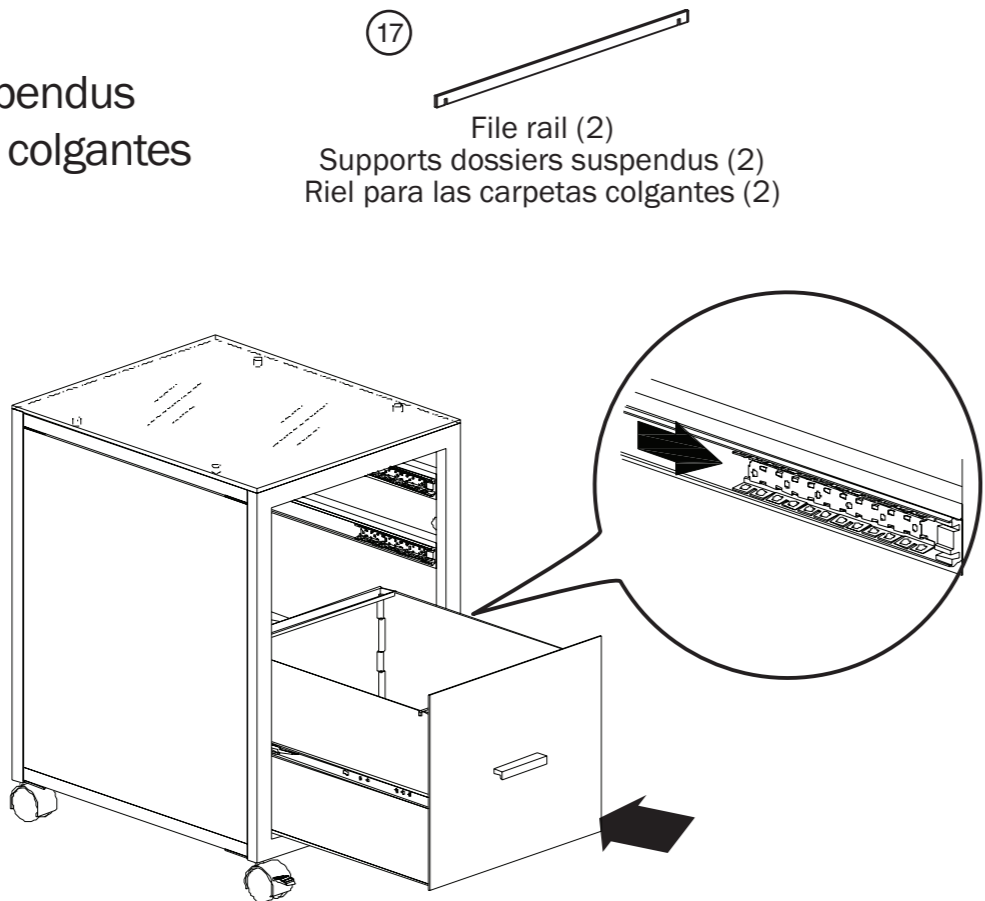
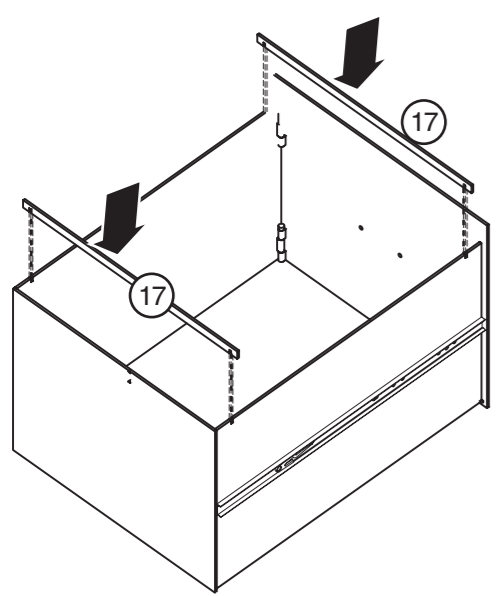

- (17) File rail (2)  
 Supports dossiers suspendus (2)  
 Riel para las carpetas colgantes (2)

**7 Assemble middle utility drawer**  
 Monter le milieu du tiroir de rangement  
 Ensamble la gaveta de uso general del medio

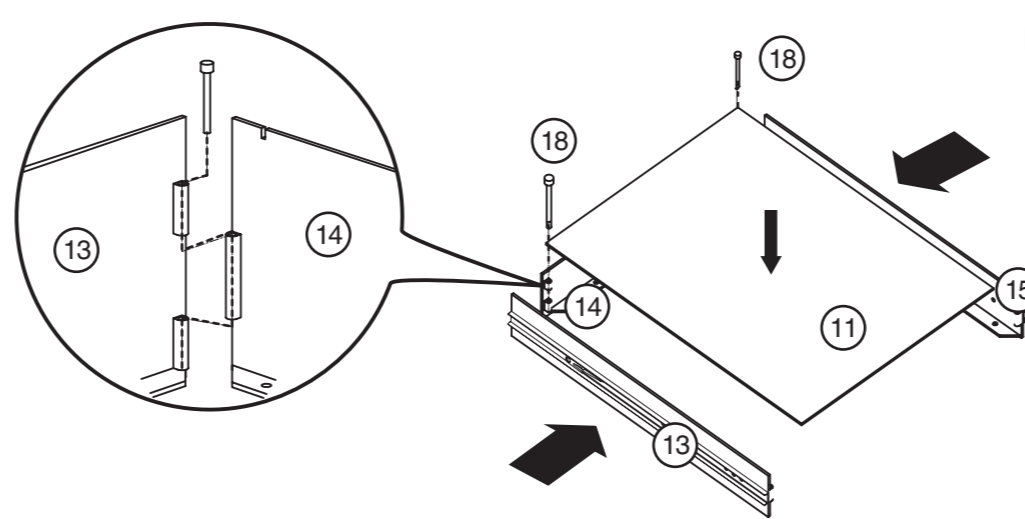

- (18) Bolts (4)  
 Vis (4)  
 Pernos (4)
- (19) Drawer handles (1)  
 Poignée du tiroir (1)  
 Agarradera de la gaveta (1)
- (22) Flat-tipped screws  
 5/32" × 12 mm (2)  
 Vis à bout plat 5/32 po × 12 mm (2)  
 Tornillos de punta plana 5/32 pulg. × 12 mm (2)
- (27) L shaped wrench (1)  
 Clé hexagonale en L (1)  
 Llave hexagonal con forma de L (1)

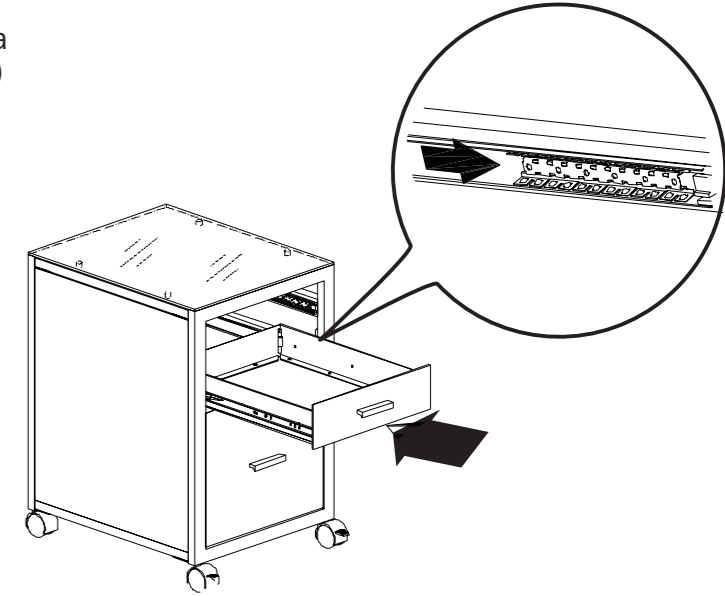
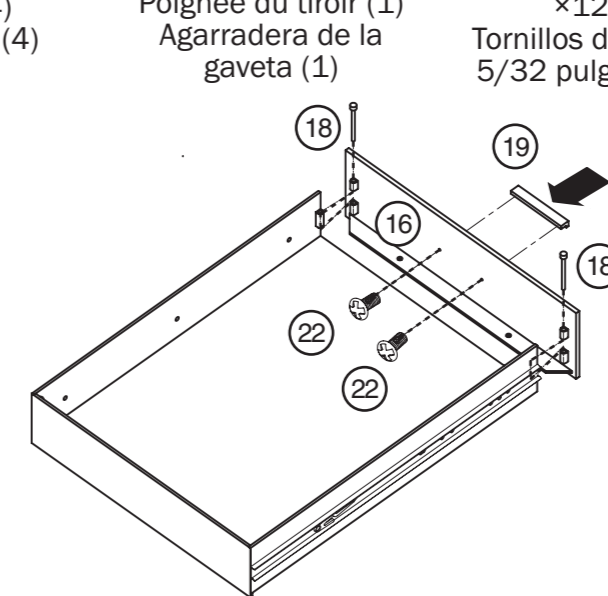

**8 Assemble top utility drawer**  
 Monter le dessus du tiroir de rangement  
 Ensamble la gaveta de uso general superior

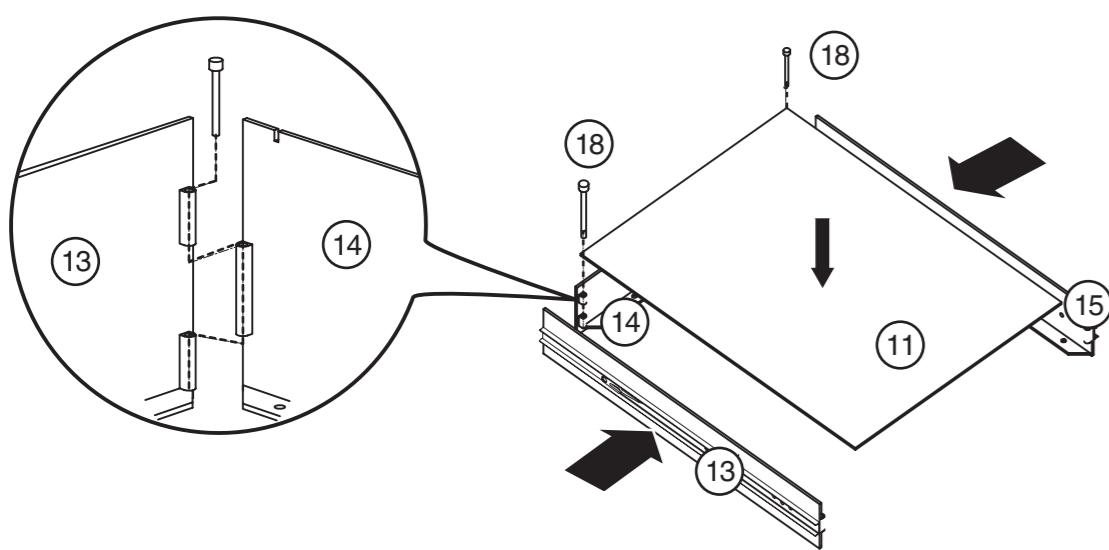

- (18) Bolts (4)  
 Vis (4)  
 Pernos (4)
- (19) Drawer handles (1)  
 Poignée du tiroir (1)  
 Agarradera de la gaveta (1)
- (22) Flat-tipped screws  
 5/32" × 12 mm (2)  
 Vis à bout plat 5/32 po × 12 mm (2)  
 Tornillos de punta plana 5/32 pulg. × 12 mm (2)
- (27) L shaped wrench (1)  
 Clé hexagonale en L (1)  
 Llave hexagonal con forma de L (1)

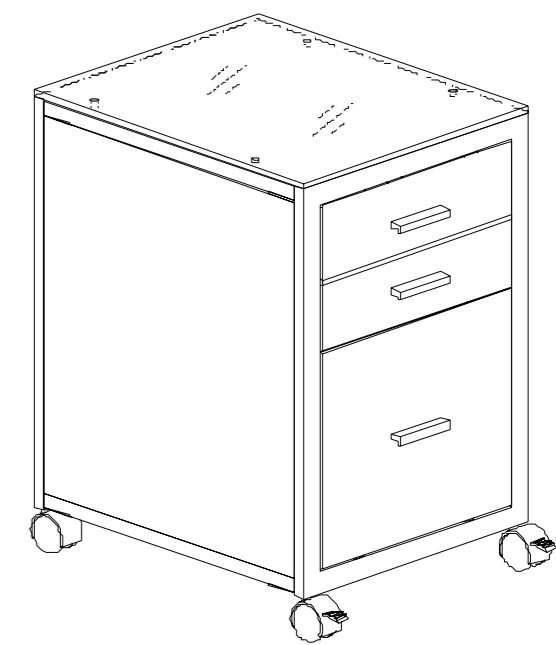
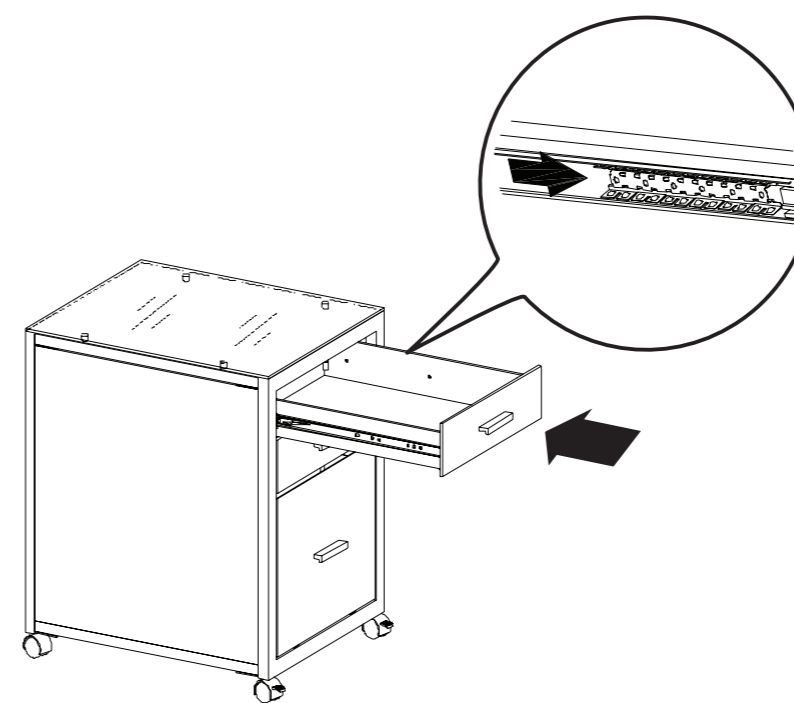
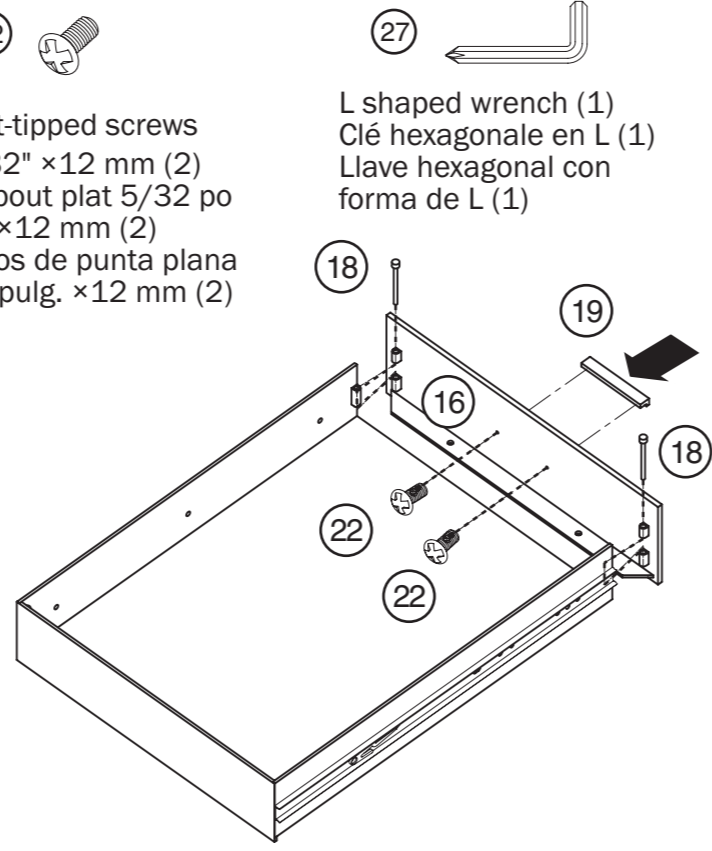

**Desk Assembly Montage du bureau Ensamblaje del escritorio**

**1 Assemble desk frame**  
 Monter la structure du bureau  
 Ensamble el bastidor del escritorio

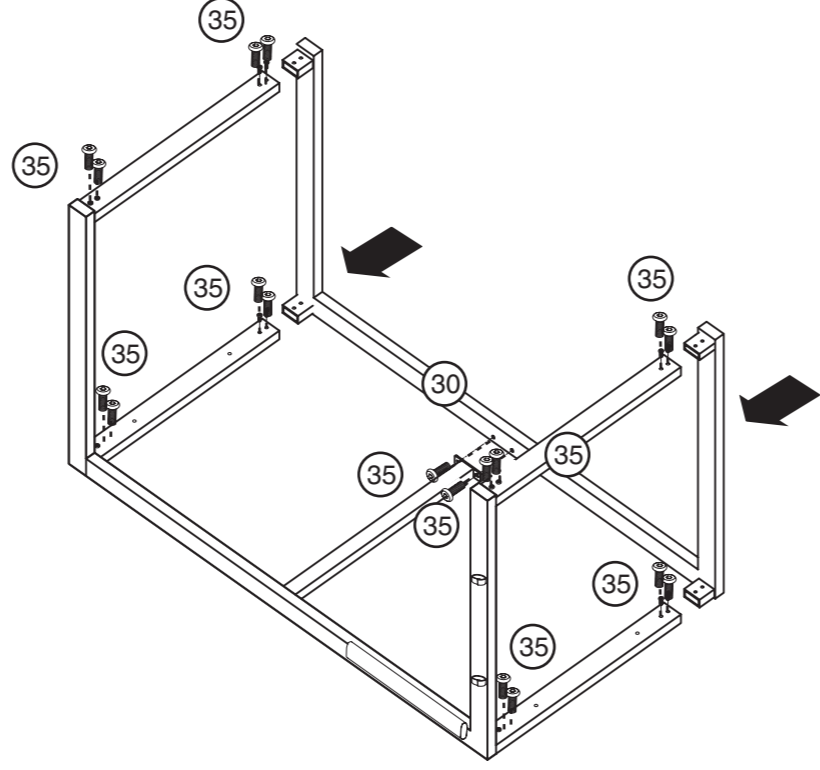
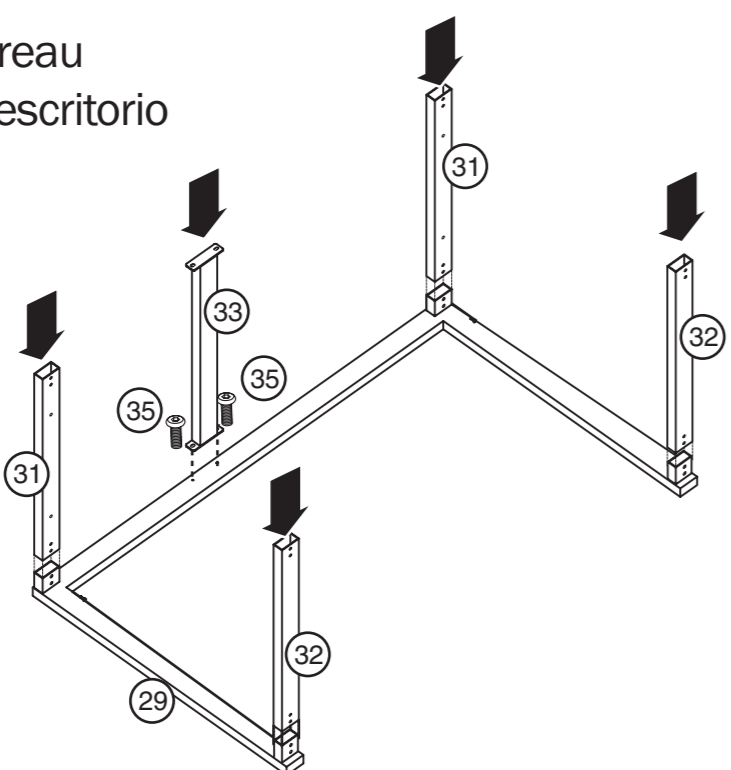

- (35) Screws M6×12 mm (20)  
 Vis M6 × 12 mm (20)  
 Tornillos M6 × 12 mm (20)
- (36) S-shaped hex wrench (1)  
 Clé hexagonale en S (1)  
 Llave hexagonal en forma de S (1)

**2 Attach glass filing cabinet top**  
 Fixer le verre du dessus du classeur mobile  
 Fije el vidrio en la parte superior del archivero

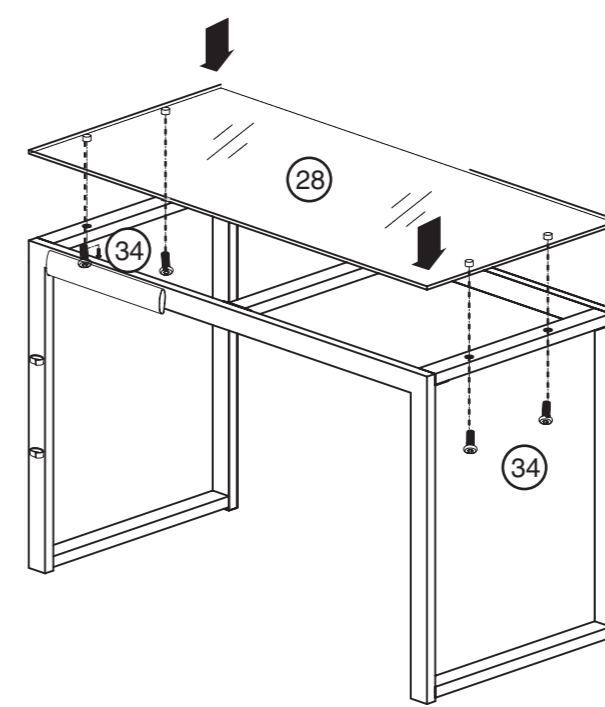

- (34) Screws M6×10 mm (4)  
 Vis M6 × 10 mm (4)  
 Tornillos M6 × 10 mm (4)
- (36) S-shaped hex wrench (1)  
 Clé hexagonale en S (1)  
 Llave hexagonal en forma de S (1)

