

Owner's Manual

Extended-Run 3-Phase Battery Cabinet



Not suitable for mobile applications.

1 – Introduction	p. 2
2 – Important Safety Instructions	p. 3
3 – Battery Cabinet Installation	p. 5
3-1 Preparation	p. 5
3-2 Transportation	p. 5
3-3 Mechanical Check	p. 5
3-4 Internal Wiring (Typical)	p. 6
3-5 Preliminary Electrical Check	p. 6
3-6 Battery Cabinet Placement	p. 6
3-7 Electrical Connection	p. 7
3-8 Battery Charger Electrical Connection (Select Models)	p. 7
3-9 Final Electrical Check	p. 7
4 – Operation and Charging	p. 8
4-1 Determine Charging Voltages	p. 8
4-2 Initial Charge	p. 8
4-3 Operational Check	p. 8
4-4 Acceptance Test (Optional)	p. 8
5 – Maintenance	p. 9
5-1 Maintenance Schedule	p. 9
5-2 Fuse Replacement	p. 9
6 – Diagrams	p. 10
6-1 Battery Cabinet Diagram (4 Shelves)	p. 10
6-2 Battery Cabinet Diagram (3 Shelves)	p. 11
6-3 Battery and Breaker Diagrams (240 VDC)	p. 12
6-4 Battery and Breaker Diagrams (+/- 240 VDC)	p. 13
6-5 Battery Charger (Select Models)	p. 14
7 – Specifications	p. 15
7-1 Dimensions and Floor Loading	p. 15
7-2 Recommended Torque	p. 15
8 – Storage and Service	p. 16
9 – Warranty	p. 16



1111 W. 35th Street, Chicago, IL 60609 USA
+1.773.869.1234 • www.tripplite.com

1 – Introduction

Tripp Lite's Extended-Run 3-Phase Battery Cabinets connect to SmartOnline 3-Phase UPS Systems to provide long-lasting battery backup for data centers, telecommunications, networks, industrial facilities, security, emergency systems and other mission-critical applications that require high capacity, high availability and extended runtime.

Features

- ▶ Battery cabinets are available in voltages from 240 VDC through 480 VDC and capacities from 33 to 720 ampere-hours with a constant power rating of up to 595 kW @ 15-minute rate.
- ▶ Battery cabinets contain multiple 6 or 12 VDC batteries connected in series for higher voltages or in series-parallel for higher voltages and capacities. Multiple battery cabinets may be connected in series for increased runtime.
- ▶ Depending on the number of individual batteries contained, each battery cabinet will have 2, 3 or 4 tiers with 8, 10 or 12 individual batteries (maximum) per tier.
- ▶ The battery cabinet structure is rated up through Seismic Zone 4 applications in compliance with the Uniform Building Code. Removable access panels facilitate periodic maintenance. There is a minimum of 6 inches of clearance above the individual batteries for access to terminals.
- ▶ Battery cabinet frame and rails are 10 gauge steel; exterior panels are 16 gauge steel. Baked powder coat finish provides chip and corrosion resistance.
- ▶ Battery cabinet is shipped bolted to pallet with a double layer of protective stretch wrap and integrated corner and top protection.
- ▶ Appropriate ventilation and convection cooling of the individual batteries is provided via ½-inch spacing between batteries. Front and rear vents allow the free flow of warmer air out of the battery cabinet.
- ▶ The internal battery series or series-parallel circuits are completely wired. The negative leg of each series string of batteries terminates into an insulated terminal block.
- ▶ An optional molded case circuit breaker is available for over-current protection. (The molded case circuit breaker can be fitted with a UV relay, shunt trip and auxiliary contacts as additional options.)
- ▶ User-supplied power output cables can be fed into the battery cabinet through built-in 8-inch conduit knockouts in the top or sides of the cabinet (gland plate included). Shorting bars provide a positive landing power connection for parallel strings in a single cabinet. All available power connection points are at the top of the cabinet, above the topmost tier of batteries.
- ▶ For improved safety, higher power density and minimized maintenance, the cabinet systems use Valve-Regulated Lead-Acid (VRLA) recombinant batteries. The electrolyte in these batteries is immobilized in either an absorbent mat separator or a gelling medium, eliminating the spilling hazards and maintenance requirements of free liquid electrolyte. There is no need to add water or measure specific gravity.
- ▶ Because the batteries are recombinant cells that employ an oxygen recombination cycle, minimal gasses are emitted during normal float charging. Each cell contains an individual valve which releases the gas products of overcharge and prevents pressure build-up within the cell.
- ▶ Select battery cabinets ("C" models) include an integrated battery charger.

2 – Important Safety Instructions

SAVE THESE INSTRUCTIONS

All sections of this manual contain instructions and warnings that must be followed during the installation and operation of the battery cabinet described in this manual. Read **ALL** instructions thoroughly before attempting to move, install or connect your battery cabinet. Failure to comply may invalidate the warranty and cause serious property damage and/or personal injury.

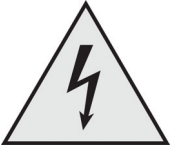

DANGER! LETHAL HIGH VOLTAGE HAZARD!

All wiring should be performed by a qualified electrician, in accordance with the warnings in this manual and all applicable electrical and safety codes. Incorrect wiring may cause serious personal injury and property damage.

Installation and Location Warnings

- Install the battery cabinet in a controlled indoor environment, away from moisture, temperature extremes, flammable liquids and gasses, conductive contaminants, dust and direct sunlight.
- Install the battery cabinet in a level, structurally sound location.
- The battery cabinet is extremely heavy; be extremely careful when moving or lifting the unit.
- Operate the battery cabinet at indoor temperatures between 32° F and 104° F (0° C and 40° C) only. For best results, maintain an indoor temperature of 77° F (25° C).
- Leave adequate space around all sides of the battery cabinet for proper ventilation. Do not block, cover or insert objects into the external ventilation openings of the battery cabinet.
- Do not place any object on the battery cabinet, especially containers of liquid.
- Do not attempt to stack the battery cabinet. Attempting to stack the battery cabinet may cause permanent damage and create a potential for serious personal injury.
- Do not attempt to unpack or move the battery cabinet without assistance. Use appropriate handling equipment rated to bear the weight and bulk of the battery cabinet, such as freight elevators, pallet jacks and forklifts. (Fully extend forks under load. Spread forks to maximum possible width under load. Lift cabinet from bottom only. Wear safety shoes.)
- For emergency use, install a fire extinguisher rated for energized electrical equipment fires (Class C rating or exact equivalent, with a non-conductive extinguishing agent) near the battery cabinet.

Connection Warnings

- The battery cabinet contains hazardous high voltages that have the potential to cause personal injury or death from electric shock.
- The battery cabinet has its own energy source. The output terminals may be live even when the battery cabinet is not connected to a UPS system.
- The battery cabinet must be suitably grounded according to all applicable electrical wiring regulations.
- Use of this equipment in life support applications where failure of this equipment can reasonably be expected to cause the failure of the life support equipment or to significantly affect its safety or effectiveness is not recommended. Do not use this equipment in the presence of a flammable anesthetic mixture with air, oxygen or nitrous oxide.
- De-energize all input and output power sources before installing cables or making electrical connections.
- Use flexible cable of sufficient length to permit battery cabinet servicing.
- Use ferrule caps to cover termination cables and prevent frayed ends from shorting on terminal blocks. Use cabling rated VW-1, FT-1 or better. Use cable sleeves and connector clamps.
- Confirm that all cables are marked correctly according to their purpose, polarity and diameter.
- Observe proper polarity by connecting negative to negative and positive to positive. Failure to observe proper polarity may damage the batteries and create a serious risk of personal injury and property damage.
- Wiring should be performed by trained, qualified electricians only.
- If the battery cabinet does not include the shunt trip option, the final installation must include an easy-access disconnect device between the battery and the load. The disconnect device must be suitably rated in accordance with applicable electrical codes and the battery cabinet rating.
- **Do not connect the integrated battery charger (included with “C” models only) to the UPS system output. The integrated battery charger requires a separate AC supply circuit.**

2 – Important Safety Instructions (continued)

Battery Warnings

- The battery cabinet does not require routine maintenance by the user. There are no user-serviceable parts inside. Only qualified, knowledgeable service personnel familiar with all required precautions should open the access panels for any reason. Keep unauthorized personnel away from batteries.
- The battery cabinet contains valve-regulated recombinant lead-acid (VRLA) batteries. Do not attempt to add water to these batteries or sample the electrolyte specific gravity.
- Valve-regulated recombinant lead-acid (VRLA) batteries can contain an explosive mixture of hydrogen gas. DO NOT SMOKE when near batteries. DO NOT cause flames or sparks near batteries. Discharge static electricity from body before touching batteries. DO NOT open or mutilate batteries—released electrolyte is harmful to the skin and eyes and may be toxic. DO NOT dispose of batteries in a fire—they may explode.
- Batteries present a risk of electrical shock and burns from high short-circuit current. Battery connection or replacement should be performed only by qualified service personnel, observing proper precautions. Use tools with insulated handles. Remove watches, rings or other metal objects. Wear rubber gloves and boots. Do not short or bridge the battery terminals with any object. Do not lay tools or metal parts on top of batteries.
- Replace batteries with equivalent batteries (same number and type) available from Tripp Lite.
- The batteries are recyclable. Refer to local codes for disposal requirements. Do not dispose of batteries except through approved channels in accordance with all applicable local, state and national regulations.
- Fuses should be replaced by qualified service personnel only. Blown fuses must be replaced with the same number and type of fuses.
- Do not connect or disconnect batteries when the UPS system is operating from the battery supply or when the unit is not in bypass mode. Disconnect the charging source prior to connection or disconnecting battery terminals.
- If the charging source remains off for an extended period of time, it should be turned on periodically to allow the batteries to recharge. The charging source should be turned on and the batteries should be recharged at least one uninterrupted 24-hour period every 3 months. Failure to recharge the batteries periodically may cause permanent battery damage.
- Allow batteries to charge uninterrupted for 24 hours after installation.
- Do not attempt to service the integrated battery charger (included with “C” models only). Contact Tripp Lite if service is required.

Note on Labeling

These symbols may appear on the product label:

V~ AC Voltage

V= DC Voltage

 Ground

+ Battery Positive

- Battery Negative

Refer to the product label for model numbers, voltage ratings and other important information.

3 – Battery Cabinet Installation



Read **Section 2 – Important Safety Instructions** Before Installation



3-1 Preparation

- At your site, prepare to off-load the battery cabinet from the delivery truck and transport it to the final installation location. Consider both the packaged weight and dimensions.
- Assure that the floor can bear the load of the specific battery cabinet being installed. The battery cabinet must be installed in a structurally sound area with a level floor that is able to bear the weight of the battery cabinet and other equipment that will be installed nearby.
- Draw a wiring schematic representing the cables connected between the battery cabinet's output terminal blocks and any external disconnect device, junction box and/or load/rectifier.
- If you plan to store the battery cabinet for an extended period before or after installation, follow the instructions in **Section 8 – Storage and Service**.

3-2 Transportation

1. Inspect the shipping container(s) for visible damage. (Do not remove the stretch wrap around the unit until it has been transported to the final installation location.) Confirm that the model name and rating match the unit you ordered. If you determine that the unit has been damaged during shipping, or if anything appears to be missing, contact Tripp Lite for assistance. Do not attempt to use the unit if it has been damaged or mishandled.
2. Do not attempt to move or unpack the battery cabinet without assistance. Use appropriate handling equipment rated to bear the weight and bulk of the battery cabinet, such as freight elevators, pallet jacks and forklifts. (Fully extend forks under load. Spread forks to maximum possible width under load. Lift cabinet from bottom only. Wear safety shoes.) Confirm that load limits for freight elevators, handling equipment and floors along the transport route will not be exceeded by the combined weight of the packaged battery cabinet, handling equipment and personnel. Confirm that the packaged unit will pass through any doorways along the intended route.
3. The battery cabinet is secured with stretch wrap to protect it during shipping and movement within a facility. Remove the stretch wrap from the battery cabinet when the unit is in the final installation location—not before.

3-3 Mechanical Check

While the assembled cabinet battery system is still on the shipping pallet, inspect all sides for impact or other damage.

1. Remove front access panels and set them aside, being careful not to scratch the finish.
2. Confirm that all individual batteries are secure in the battery cabinet and that no batteries have been damaged.
3. Confirm that none of the internal parts (terminal blocks, fuse blocks, fuses, circuit breakers and other parts) have been damaged.
4. If the battery cabinet includes an integrated battery charger (“C” models only), examine the wires at the DC output terminal closely. If any of the leads are bent or otherwise damaged from shipping, contact Tripp Lite. Damaged leads could cause a battery short circuit.
5. Note the individual battery model number and refer to **Section 7-2** for the battery's terminal type and recommended torque.
6. Use insulated tools to tighten all the battery terminal connections to the recommended torque.
7. Use insulated tools to tighten the cables from the positive and negative output terminals at the end batteries to the output terminal block, fuse block or circuit breaker.

3 – Battery Cabinet Installation (continued)

3-4 Internal Wiring (Typical)

- Battery cabinets use multiple 6 VDC or 12 VDC batteries connected in series to provide nominal DC voltages ranging from 240 VDC to 480 VDC.
- Internal cabling is sized for specific application load currents. The insulated cables can be 2 AWG, 4 AWG, 2/0 AWG, 4/0 AWG or dual 2/0 AWG.
- Each battery cabinet includes a specific wiring diagram. Some battery cabinets may contain series-parallel battery strings. Others may require a single series string that occupies more than one cabinet. The installer must complete the series connections between separate cabinets when the series string occupies more than one cabinet. The cables, hardware and instructions required to complete the connection will be inside one of the cabinets.
- Battery cabinets that include a molded case circuit breaker may or may not use a fuse.
- All fuses, disconnect switches and circuit breakers are in the top tier of the battery cabinet.
- Terminal blocks, copper bussing or direct circuit breaker connections for connecting to the load are in the top tier of the battery cabinet.
- All load connection polarities will be marked by a POS (+) or NEG (-) label.
- Some battery cabinets are provided with a two-pole branch circuit overcurrent protection device. These cabinets may be wired directly to the load or UPS.
- Some battery cabinets are not provided with branch circuit overcurrent protection. The installer must supply an easy-access disconnect and branch circuit overcurrent protection device rated in accordance with all applicable electrical codes.
WARNING: To reduce the risk of fire, connect only to a circuit provided with branch circuit overcurrent protection rated in accordance with the National Electrical Code (NEC), ANSI/NFPA 70.
- If the battery cabinet includes an integrated battery charger (“C” models only), the internal cabinet wiring will be preinstalled and the charger will include fusing for 120 VAC input. **The charger input must be connected to a separate AC supply circuit (30 A, 120 VAC, 60 Hz), not the UPS system.**

3-5 Preliminary Electrical Check

1. Measure the battery cabinet output voltage at the output load connection points. (Measure voltage with a digital voltmeter.)
2. The measured voltage should approximately match the voltage listed on the battery cabinet nameplate. The battery cabinet output voltage will be equal to the number of individual batteries installed in series multiplied by the unit voltage. (For example: 40 batteries x 12.84 VDC = 513.6 VDC output; 40 batteries x 6.42 VDC = 256.8 VDC output.)
3. If the measured voltage is significantly different than anticipated, determine the cause (e.g. low charge, shorted cell, reversed battery, faulty wiring) and correct the voltage disparity before proceeding.

3-6 Battery Cabinet Placement

Place the battery cabinet in a cool location with free airflow that is away from direct heat sources. The lifespan of a battery can be affected dramatically by elevated temperature, decreasing 50% for each 15° above 77° F.

1. Prepare the surface where the cabinet will be placed. The surface must be clean, flat and able to support the battery cabinet and other equipment installed nearby. (See **Section 7-1** for floor loading specifications.)
2. Allow adequate clearance around the battery cabinet for ventilation and maintenance. The front panel must be accessible and removable to allow easy access to internal batteries, internal fuses and other overcurrent protection devices. (See **Section 7-1** for dimensions. See **Section 6-1 or 6-2** for detailed battery cabinet measurements.)
3. If the cabinet will be anchored to the floor, install appropriate anchor bolts in the mounting hole at the bottom of the cabinet. Use washers to create a level surface between the mounting areas around the anchor bolts.
4. Using extreme caution, remove the bolts securing the battery cabinet to the shipping pallet.
5. Forklift forks should be at maximum width within the cabinet clearance opening and fully inserted to prevent tipping. Lift cabinet from bottom only. Be careful not to damage the sheet metal floor of the cabinet with the forks.
6. If the battery cabinet will be secured to the floor, carefully align and lower the battery cabinet down on the floor anchor bolts and secure it in place.
7. If the cabinet will not be secured to the floor, lower it into the designated space and then level it using shims. (Leveling does not affect performance but does align the battery cabinet with other equipment in the facility.)

3 – Battery Cabinet Installation (continued)

3-7 Electrical Connection

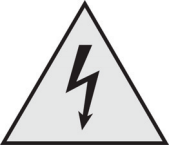

DANGER! LETHAL HIGH VOLTAGE HAZARD!

All wiring should be performed by a qualified electrician, in accordance with the warnings in this manual and all applicable electrical and safety codes. Incorrect wiring may cause serious personal injury and property damage.

- The battery cabinet should be connected to the load through a DC disconnect switch or a DC circuit breaker. This allows the battery to be disconnected from the load and charger for maintenance and/or repair.
 - The DC rated fuses and DC molded case circuit breakers are UL-listed for branch circuit protection. If replacement is required, UL-listed components with the same voltage and current rating must be used.
 - The size of the load connection cables must consider maximum allowable voltage drop as well as the cables' continuous ampere capacity and anticipated ampere discharge rate of the individual battery cabinet. A maximum voltage drop of 1.5 VDC in the load connection cables is recommended.
 - Refer to all applicable local, state and national codes (including NEC) for appropriate cable size and ratings.
 - External circuit protection devices (fuses or circuit breakers) must consider the discharge rate of the battery, the wiring to be protected and the DC short circuit current of the battery.
 - When the battery cabinets are connected in parallel, they should be joined together with separate output cables of equal total length at a junction box or other suitable distribution panel.
 - If the battery cabinet includes an integrated battery charger ("C" models only), the charger input must be connected to an AC supply circuit separate from the UPS system.
1. Remove the battery cabinet's access panels to access internal components. Use a digital voltmeter when voltage measurements are required.
 2. Determine if the battery has been inadvertently grounded by measuring the voltage between the battery cabinet grounding lug and the positive load connection point within the cabinet. This voltage should measure 0 (zero) VDC. If the measured voltage is not zero, determine the cause and correct before proceeding.
 3. Place the internal circuit breaker in an open position during the connection of the output cables to prevent damage if the cables are accidentally shorted.
 4. The top and sides of the battery cabinet include knockouts for load connection cable entry. Punch out the appropriate knockout and connect the conduit or cable bushing.
 5. The output terminal blocks, fuse blocks, disconnect switches and circuit breakers will accommodate cables up to 500 MCM (500 kcmil).
 6. Feed the positive and negative cable from the open external disconnect switch through the conduit/cable bushing and connect to the respective output terminals inside the battery cabinet.
 7. Reinstall any internal cabinet fuses that were removed in step 2 (above). All disconnect switches or circuit breakers must remain in the open position during reinstallation of the fuses.
 8. Connect an appropriate equipment grounding cable to the grounding lug mounted in the top of the battery cabinet or to the grounding pad on the rear leg of the battery cabinet.

3-8 Battery Charger Electrical Connection (Select Models)

1. Select battery cabinets ("C" models only) include an integrated battery charger. The charger includes fusing for 120 VAC input. Refer to **Section 6-5** for a terminal block diagram and additional battery charger information.
2. Set the battery cabinet input voltage to 120 VAC by jumpering these terminals: 2 and 3, 3 and 4, 5 and 6.
3. Connect charger terminals 7 and 8 to a 30-amp, 120 VAC, 60 Hz power source. **Warning: Do not connect the battery charger to the UPS system output. The battery charger requires a separate AC supply circuit.**

3-9 Final Electrical Check

Before closing any connecting circuit breaker or disconnect switch, complete these verification steps:

1. Verify that the battery cabinet output voltage is correct.
2. If battery cabinets will be operated in parallel, verify that the individual system output voltages match within 2 VDC.
3. Verify that the voltage measured between either output terminal and the battery cabinet ground is zero.
4. If any of the above verification steps shows an irregularity, determine and correct the cause before proceeding.

4 – Operation and Charging

4-1 Determine Charging Voltages

To determine the appropriate equalization (freshening) charge voltage and float charge voltage, multiply the number of batteries connected in series in the battery cabinet by the recommended charging voltage per unit.

For example:

A +/- 240 VDC cabinet containing 40 each of the UPS12-400MR batteries in series would use the following charging voltages:

Freshening/Equalization Charge Voltage = $20 \times 14.4 \text{ VDC/unit average} = +/- 288 \text{ VDC}$

Float Charge Voltage = $20 \times (13.5 \text{ to } 13.8 \text{ VDC/unit average}) = +/- 270 \text{ to } 276 \text{ VDC}$

Note: Some battery cabinets may contain more than one series string connected in parallel within the cabinet. The calculation for properly charging the battery cabinet should follow the procedure above, considering the number of batteries in a single series string.

4-2 Initial Charge

After the correct charging voltages have been calculated, follow these steps:

1. Adjust the charger/rectifier equalization and float voltage outputs to the appropriate level.
2. Place the charger/rectifier in equalization mode.
3. Close the disconnect switch/circuit breaker connection from the charger/rectifier to the battery cabinet(s) and start a 24-hour freshening charge at the equalization charge.
4. After a few minutes on charge, monitor the voltage across several of the individual batteries to assure they are charging at the proper value.
5. Following completion of the freshening charge, place the charger/rectifier in float charge mode.
6. After the battery cabinet has been on float for 1 to 24 hours, complete the operational check (**Section 4-3**).

4-3 Operational Check

1. Measure and record the total system float voltage. Measure at the battery terminals.
2. Measure and record the system float current using a clamp-on ammeter.
3. Measure and record the float voltage of individual battery units.
4. Measure and record the temperature of several of the batteries. (Measure battery temperature with a digital thermometer by placing the surface thermocouple on the flat surface of the negative terminal—not the “L” connection surface. An infrared temperature monitor can also be used.)
5. Optional: Perform impedance and conductance tests on individual battery units. These tests require special equipment, but the data can be useful in trending the system over time or identifying suspect units during later periodic checks. It may be necessary to disconnect the battery system from the charger/load during these checks.
6. If the acceptance test is being performed, proceed to **Section 4-4**. If the acceptance test is not being performed, reinstall the cabinet’s access panels. The battery cabinet is now in operation.

4-4 Acceptance Test (Optional)

1. Remove the battery cabinet’s access panels to access internal components. Use a digital voltmeter when voltage measurements are required.
2. Determine the discharge rate (e.g. 15 seconds, 5 minutes, 15 minutes) at which the battery is to be tested.
3. Select a battery from the center of the battery cabinet and measure the temperature at the flat surface of the negative terminal. If the temperature is below 74° F or above 80° F, the test load should be temperature compensated accordingly.
4. Review the final check data and assure that all unit float voltages are acceptable.
5. During the acceptance discharge test, monitor the cabinet system output voltage at the cabinet, the output current and discharge time as a back-up to monitoring at the critical load.
6. Run the test in accordance with the IEEE standard.
7. Reinstall the cabinet’s access panels. The battery cabinet is now in operation.

5 – Maintenance

The battery cabinet contains valve-regulated recombinant lead-acid (VRLA) batteries, which are maintenance-free relative to the electrolyte. You cannot add water to these batteries or sample the electrolyte specific gravity. It is necessary, however, to periodically check the charging voltage, temperature and connections of the individual battery units.

5-1 Maintenance Schedule

Quarterly Check

1. Measure individual battery unit temperature. (Measure with a digital thermometer by placing the surface thermocouple on the flat surface of the negative terminal—not the “L” connection surface. An infrared temperature monitor can also be used. Temperatures below 77° F reduce battery performance and temperatures above 77° F reduce battery lifespan. Battery lifespan is reduced by 50% for each 15° above 77° F. For example, battery lifespan will be reduced by half at 92° F.)
2. Measure individual battery unit float charging voltages. (Measure voltage with a digital voltmeter. Measured voltage should be between 13.2 VDC and 14.2 VDC. Battery units outside this range should be replaced.)
3. Measure total battery cabinet float charging voltage.

Semiannual Check

1. Repeat quarterly check.
2. (Optional) Measure impedance or conductance of individual battery units.
3. (Optional) Perform a high-rate, 100 A, 10 second performance capacity test of individual battery units. (The performance capacity test is identical to the acceptance test in **Section 4-4**, and the same procedure should be followed.)

Annual Check

1. Repeat semiannual check.
2. Use insulated tools to tighten all connections to the recommended torque. (See **Section 7-2** for recommended torque values.)
3. (Optional) Measure inter-battery connection resistance.

5-2 Fuse Replacement

Warning: Fuses should be replaced by qualified service personnel only. Blown fuses must be replaced with the same number and type of fuses.

1. The battery cabinet may contain a UL-listed, branch-rated fuse in the positive output (upper front of cabinet).
2. Before attempting to replace the fuse, open the disconnect between the battery cabinet and the load/charger.
3. Remove the front panel from the battery cabinet. Before attempting to replace the fuse, confirm that the battery is not shorted to the cabinet. Use a digital voltmeter to measure the voltage between the cabinet and both sides of the fuse holder. This voltage should measure 0 (zero) VDC. If the measured voltage is not zero, determine the cause and correct before proceeding.
4. Wearing rubber gloves and using insulated tools, remove any cables and/or terminal plates from the output side of the fuse holder. Using the appropriate hex socket, remove the fuse from the holder.
5. The replacement fuse must have the same voltage and current rating as the fuse being replaced (check the label on the fuse being replaced).
6. For nominal battery cabinet voltages less than or equal to 384 VDC, use fuses rated at 500 VDC. For nominal battery cabinet voltages greater than 384 VDC, use fuses rated at 700 VDC.
7. Install the replacement fuse and reconnect the output cables and/or terminal plates to the output side of the fuse holder.
8. Reinstall the battery cabinet front panel and close the disconnect between the battery cabinet and the load/charger.

6 – Diagrams

6-1 Battery Cabinet Diagram (4 Shelves)

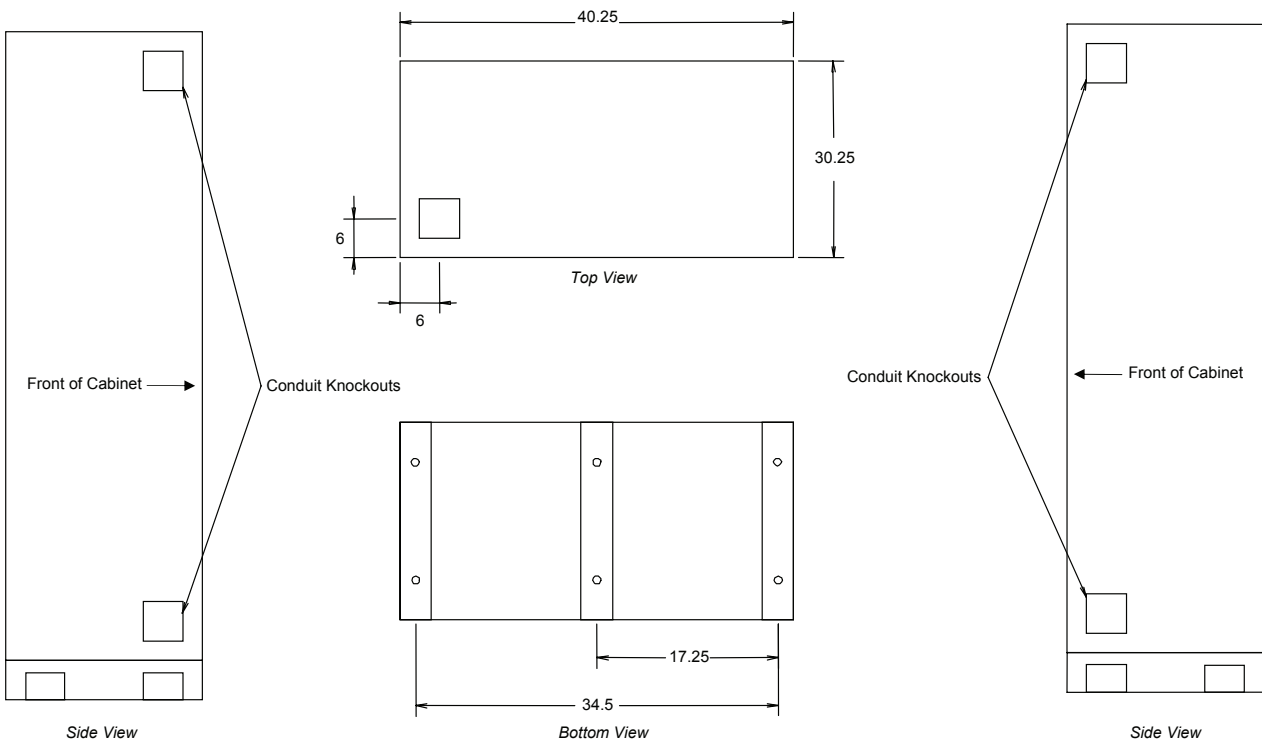
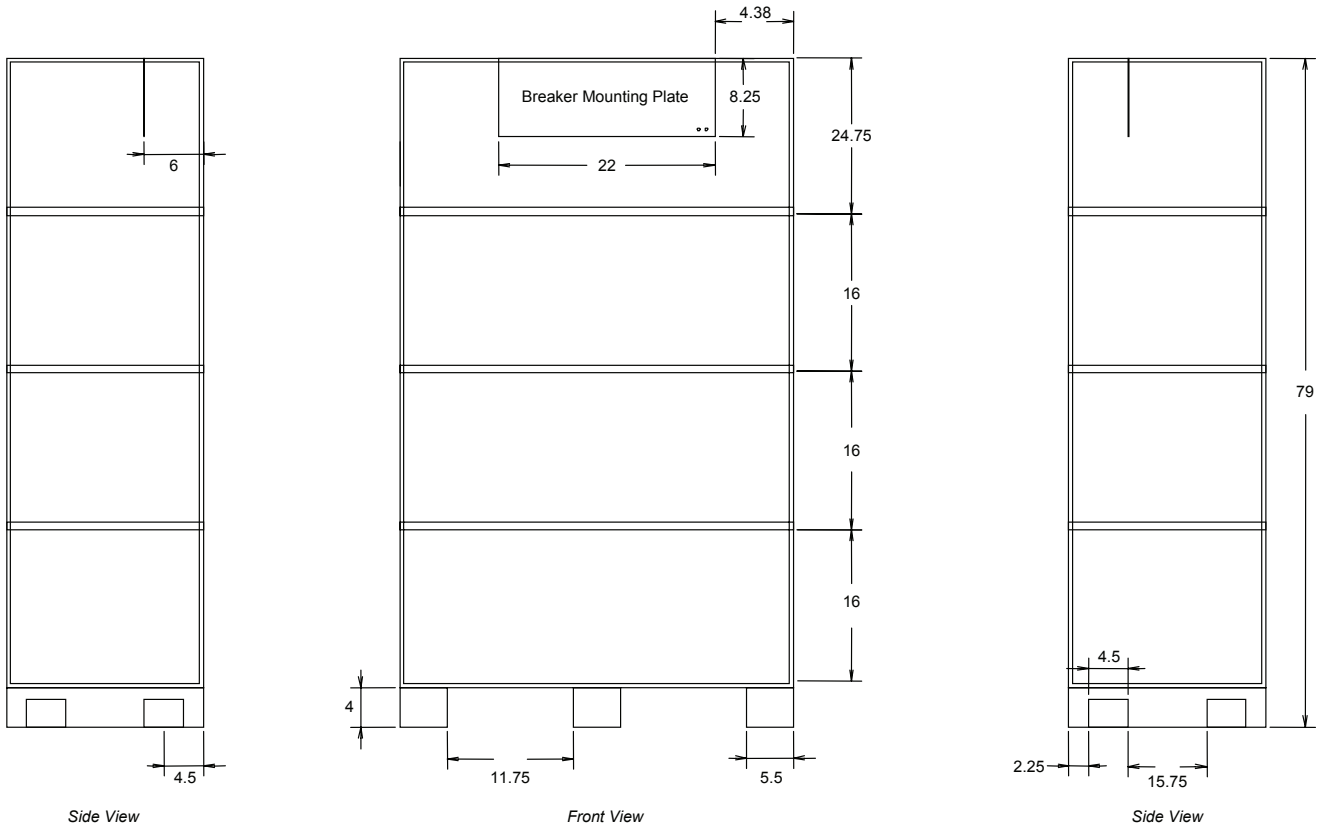

Note: All dimensions are in inches.

6 – Diagrams (continued)

6-2 Battery Cabinet Diagram (3 Shelves)

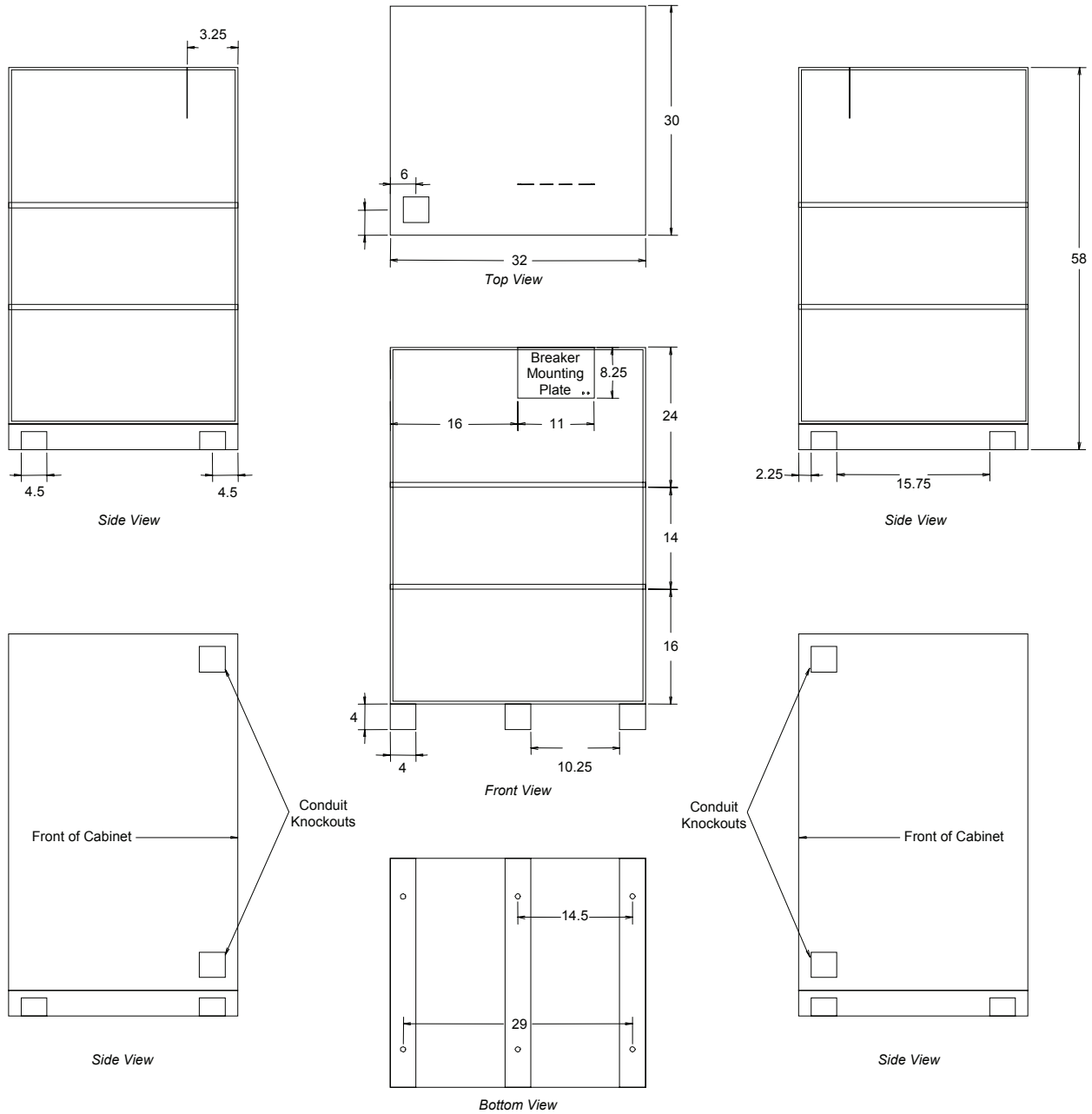

Note: All dimensions are inches.

6 – Diagrams (continued)

6-3 Battery and Breaker Diagrams (240 VDC)

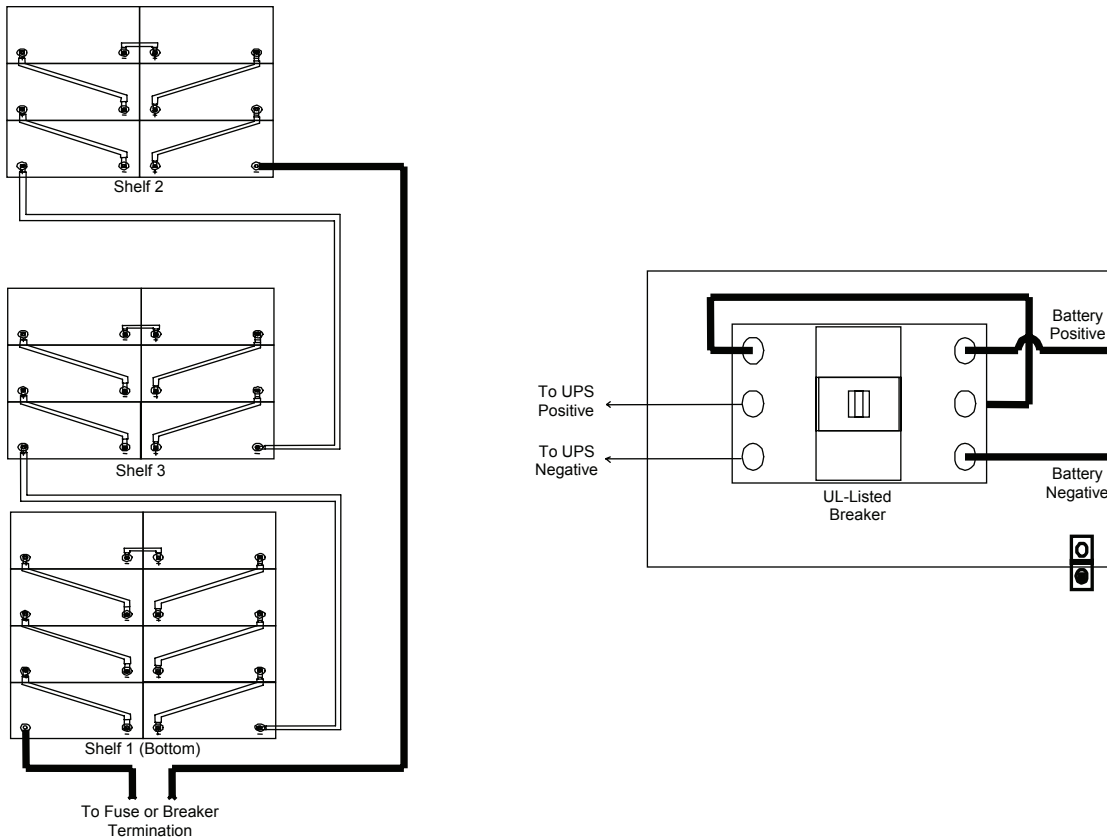

Notes:

- All internal wiring is UL-listed, MTW, 125C Hi-Flex cable.
- Terminal block is UL-recognized and rated for 600 VDC.
- Breaker is UL-listed and rated for 150 A, 600 VDC, 25 KAIC.
- Cabinets with breakers are shipped with the breaker in the off/open position.
- Battery arrangements shown are typical but may vary depending on cabinet and battery type.

6 – Diagrams (continued)

6-4 Battery and Breaker Diagrams (+/- 240 VDC)

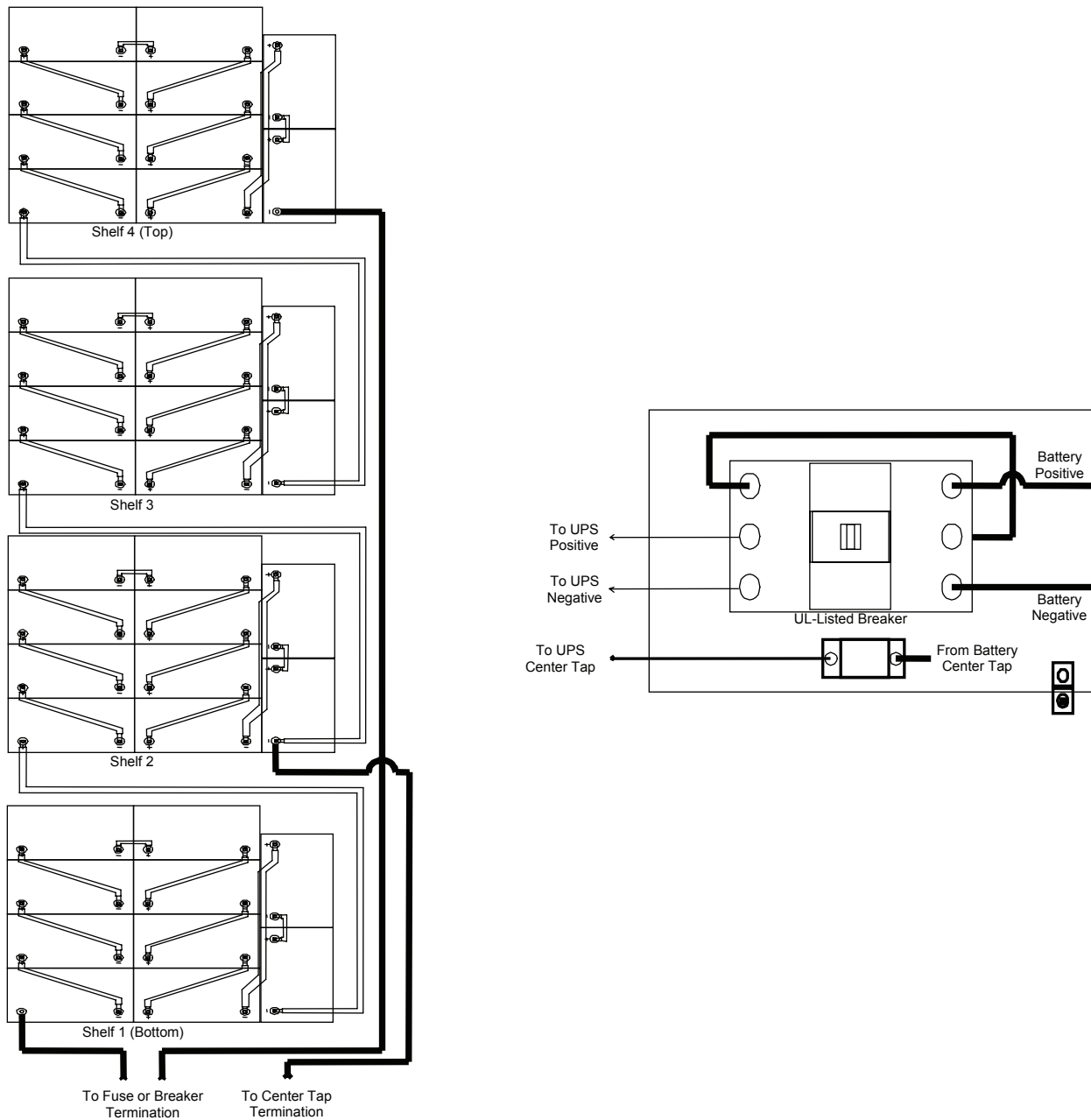

Notes:

- All internal wiring is UL-listed, MTW, 125C Hi-Flex cable.
- Terminal block is UL-recognized and rated for 600 VDC.
- Breaker is UL-listed and rated for 250 A, 600 VDC, 25 KAIC.
- Cabinets with breakers are shipped with the breaker in the off/open position.
- Battery arrangements shown are typical but may vary depending on cabinet and battery type.

6 – Diagrams (continued)

6-5 Integrated Battery Charger (Select Models)

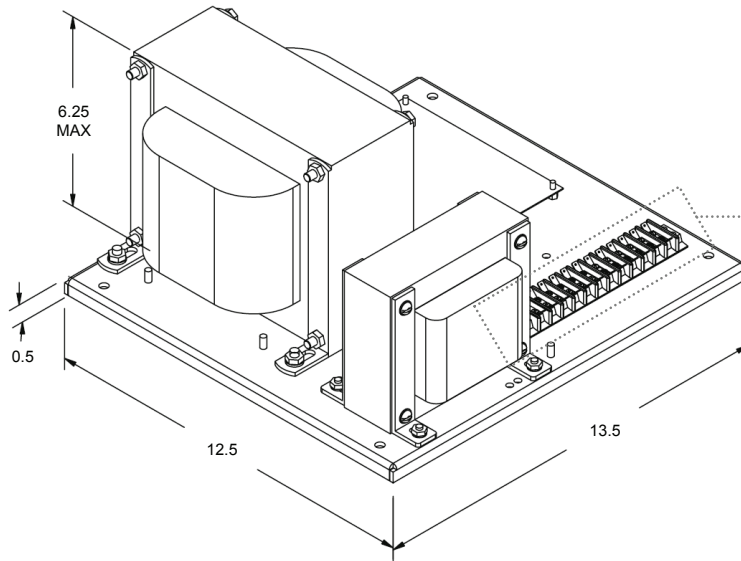

Terminal Block Detail

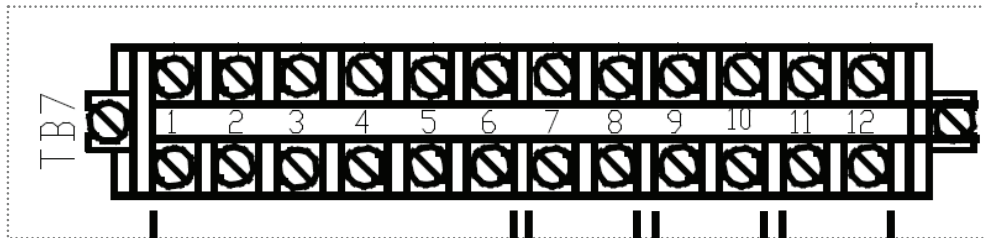

Input Voltage Selection

For 120 VAC Jumper:
2 & 3, 3 & 4, 5 & 6

For 208 VAC Jumper:
1 & 2, 4 & 5

For 240 VAC Jumper:
2 & 3, 4 & 5

AC Input

L

N

-

+

**120
VAC
Output**

Output

Warning: Do not connect the battery charger AC input to the UPS system output. The battery charger requires a separate AC supply circuit.

Notes:

- All dimensions are inches.
- AC input is selectable 120/208/240 VAC, 60 Hz.
- Constant voltage output.
- Electronic current limiting and high voltage shutdown.
- AC and DC fusing. Included AC fusing is suitable for 120 VAC input.
- Temperature compensation with remote battery temperature sensor.
- Auxiliary output circuit for “Charger OK” indicator.

7 – Specifications

7-1 Dimensions and Floor Loading

Battery Cabinet Model	Shelves	Dimensions (Width x Depth x Height)	Weight	Floor Loading
BP240V99	3	32 x 30 x 58 inches (81.3 x 76.2 x 147.3 cm)	1760 lb (800 kg)	264 lb/ft ² (1292 kg/m ²)
BP240V120	3	32 x 30 x 58 inches (81.3 x 76.2 x 147.3 cm)	1920 lb (873 kg)	288 lb/ft ² (1410 kg/m ²)
BP240V1207C	3	32 x 30 x 58 inches (81.3 x 76.2 x 147.3 cm)	1983 lb (901 kg)	297 lb/ft ² (1452 kg/m ²)
BP240V150	3	32 x 30 x 58 inches (81.3 x 76.2 x 147.3 cm)	2400 lb (1091 kg)	360 lb/ft ² (1762 kg/m ²)
BP240V1507C	3	32 x 30 x 58 inches (81.3 x 76.2 x 147.3 cm)	2463 lb (1120 kg)	369 lb/ft ² (1804 kg/m ²)
BP480V55	3	32 x 30 x 58 inches (81.3 x 76.2 x 147.3 cm)	2050 lb (932 kg)	308 lb/ft ² (1505 kg/m ²)
BP480V78	4	40.25 x 30.25 x 79 inches (102.2 x 76.8 x 200.7 cm)	2960 lb (1345 kg)	350 lb/ft ² (1714 kg/m ²)
BP480V103	4	40.25 x 30.25 x 79 inches (102.2 x 76.8 x 200.7 cm)	3650 lb (1659 kg)	432 lb/ft ² (2114 kg/m ²)
BP480V140	4	40.25 x 30.25 x 79 inches (102.2 x 76.8 x 200.7 cm)	4625 lb (2102 kg)	547 lb/ft ² (2678 kg/m ²)
BP348V55	4	40.25 x 30.25 x 79 inches (102.2 x 76.8 x 200.7 cm)	2284 lb (1038 kg)	271 lb/ft ² (1322 kg/m ²)
BP348V78	4	40.25 x 30.25 x 79 inches (102.2 x 76.8 x 200.7 cm)	2545 lb (1157 kg)	301 lb/ft ² (1474 kg/m ²)
BP348V103	4	40.25 x 30.25 x 79 inches (102.2 x 76.8 x 200.7 cm)	2783 lb (1265 kg)	330 lb/ft ² (1612 kg/m ²)
BP348V150	4	40.25 x 30.25 x 79 inches (102.2 x 76.8 x 200.7 cm)	3489 lb (1586 kg)	413 lb/ft ² (2021 kg/m ²)

7-2 Recommended Torque

Battery Cabinet Model	Individual Battery Unit Model	Terminal Type	Torque
BP240V99	UPS12-350MR	1/4-20 Threaded Insert	110 in·lb (12.4 N·m)
BP240V120	UPS12-400MR	1/4-20 Threaded Insert	110 in·lb (12.4 N·m)
BP240V1207C	UPS12-400MR	1/4-20 Threaded Insert	110 in·lb (12.4 N·m)
BP240V150	UPS12-490MR	1/4-20 Threaded Insert	110 in·lb (12.4 N·m)
BP240V1507C	UPS12-490MR	1/4-20 Threaded Insert	110 in·lb (12.4 N·m)
BP480V55	UPS12-210MR	10-32 Threaded Insert	25 in·lb (2.8 N·m)
BP480V78	UPS12-300MR	1/4-20 Threaded Insert	110 in·lb (12.4 N·m)
BP480V103	UPS12-400MR	1/4-20 Threaded Insert	110 in·lb (12.4 N·m)
BP480V140	UPS12-490MR	1/4-20 Threaded Insert	110 in·lb (12.4 N·m)
BP348V55	UPS12-210MR	10-32 Threaded Insert	25 in·lb (2.8 N·m)
BP348V78	UPS12-300MR	1/4-20 Threaded Insert	110 in·lb (12.4 N·m)
BP348V103	UPS12-400MR	1/4-20 Threaded Insert	110 in·lb (12.4 N·m)
BP348V150	UPS12-490MR	1/4-20 Threaded Insert	110 in·lb (12.4 N·m)

8 – Storage and Service

Storage

The battery cabinet must be stored in a clean, secure environment with a temperature less than 40° C (104° F) and a relative humidity less than 90% (non-condensing). Store the battery cabinet in its original shipping container if possible. Charge the batteries for at least 24 hours prior to use. Do not rely on the battery cabinet to provide backup power to connected equipment until the batteries are fully charged. *Note: If the UPS system remains off for an extended period of time, it should be turned on periodically to allow the batteries to recharge. The UPS system should be turned on and the batteries should be recharged at least one uninterrupted 24-hour period every 3 months. Failure to recharge the batteries periodically may cause irreversible battery damage.*

Service

The battery cabinet is covered by the limited warranty described in this manual. Site survey service programs, start-up service programs, preventative maintenance service programs and on-site warranty options (2, 3 or 4 years) are also available. For more information, call Tripp Lite Customer Service at +1.773.869.1234.

9 – Warranty

Limited Warranty

Seller warrants this product, if used in accordance with all applicable instructions, to be free from original defects in material and workmanship for a period of 1 year from the date of initial purchase. If the product should prove defective in material or workmanship within that period, Seller will repair or replace the product, in its sole discretion. Service under this Warranty includes parts and Tripp Lite service center labor. On-site service plans are available from Tripp Lite through authorized service partners (in most areas). Contact Tripp Lite Customer Service at +1.773.869.1234 for details. International customers should contact Tripp Lite support at intlservice@tripplite.com.

THIS WARRANTY DOES NOT APPLY TO NORMAL WEAR OR TO DAMAGE RESULTING FROM ACCIDENT, MISUSE, ABUSE OR NEGLIGENCE. SELLER MAKES NO EXPRESS WARRANTIES OTHER THAN THE WARRANTY EXPRESSLY SET FORTH HEREIN. EXCEPT TO THE EXTENT PROHIBITED BY APPLICABLE LAW, ALL IMPLIED WARRANTIES, INCLUDING ALL WARRANTIES OF MERCHANTABILITY OR FITNESS, ARE LIMITED IN DURATION TO THE WARRANTY PERIOD SET FORTH ABOVE; AND THIS WARRANTY EXPRESSLY EXCLUDES ALL INCIDENTAL AND CONSEQUENTIAL DAMAGES. (Some states do not allow limitations on how long an implied warranty lasts, and some states do not allow the exclusion or limitation of incidental or consequential damages, so the above limitations or exclusions may not apply to you. This Warranty gives you specific legal rights, and you may have other rights which vary from jurisdiction to jurisdiction.)

Tripp Lite; 1111 W. 35th Street; Chicago IL 60609; USA

WARNING: The individual user should take care to determine prior to use whether this device is suitable, adequate or safe for the use intended. Since individual applications are subject to great variation, the manufacturer makes no representation or warranty as to the suitability or fitness of these devices for any specific application.

Regulatory Compliance Identification Numbers

For the purpose of regulatory compliance certifications and identification, your Tripp Lite product has been assigned a unique series number. The series number can be found on the product nameplate label, along with all required approval markings and information. When requesting compliance information for this product, always refer to the series number. The series number should not be confused with the marking name or model number of the product.

Tripp Lite has a policy of continuous improvement. Specifications are subject to change without notice.

Made in China.



1111 W. 35th Street, Chicago, IL 60609 USA
+1.773.869.1234 • www.tripplite.com