



DEV9100-22

CGS-22 20" Dual Series Housing

Foodservice System Housing for Drop-In Cartridges



CGS-22 20" Dual Series Housing: DEV9100-22

BENEFITS

- 20" low profile Slim Line dual bowl housing in Series configuration
- Manufactured of durable polypropylene and has excellent chemical resistance
- System includes pre-mounted water pressure gauge
- Equipped with a pressure relief button to relieve water pressure during cartridge changes
- Includes wall mounting bracket and hardware for fast and easy installation
- System is shipped fully assembled
- Choose the appropriate cartridges for your needs
- Cartridges sold separately

INSTALLATION TIPS

- Choose a mounting location suitable to support the full weight of the system when operating
- Install vertically so bowls hang down
- Allow 2-1/2" clearance below the cartridge for easy cartridge replacement
- Make sure O-ring on bowl is sufficiently lubricated
- Always screw on bowls by hand; do not use a housing wrench
- Flush filter by running water through filter according to cartridge instructions

OPERATION TIPS

- Change cartridges on a regular 6 month preventative maintenance program
- Change cartridges when capacity is reached or when pressure decreases
- Always inspect O-ring; change and/or lubricate if necessary
- Clean bowl with mild solution of detergent before inserting new cartridge
- Always flush the filter cartridge at time of installation and cartridge change

APPLICATION/SIZING

- For foodservice applications
- Bowl housing assembly accepts drop in cartridges
- Capacity: varies according to filter cartridge used

CGS-22 20" Dual Series Housing

SPECIFICATIONS

Overall Dimensions:
25"H x 13.5"W x 5.25"D

Inlet connection: 1/2"

Outlet connection: 1/2"

Service Flow Rate:
Maximum 4.0 gpm (15.1 Lpm)

Pressure Requirements:
30 - 125 psi (2.1 - 8.6 bar), non-shock

Temperature: 40 - 100°F (4.4 - 38°C)

No electrical connection required

The contaminants or other substances removed by this drinking water system are not necessarily in your water. Do not use with water that is microbiologically unsafe or of unknown quality without adequate disinfection before or after the system. Systems certified for cyst reduction may be used with disinfected water that may contain filterable cysts.

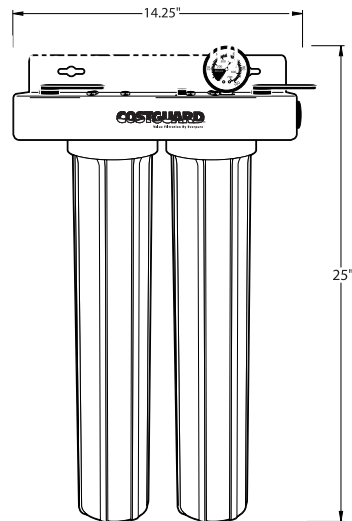

WARRANTY

Everpure water treatment systems (excluding replaceable elements) are covered by a limited warranty against defects in material and workmanship for a period of five years after date of purchase. Everpure replaceable elements (filter cartridges and water treatment cartridges) are covered by a limited warranty against defects in material and workmanship for a period of one year after date of purchase. See printed warranty for details. Everpure will provide a copy of the warranty upon request.



System Tested and Certified by NSF International against NSF/ANSI Standard 42 for the reduction of:

Standard No. 42: Aesthetic Effects
Chemical Unit
Taste and Odor Reduction
Chlorine Reduction

NOTE: NSF Listings vary according to cartridges used in housing.



EVERPURE, INC.
2375 Sanders Road
Northbrook, IL 60062
Toll Free (800) 323-7873
Tel (847) 205-6000
Fax (800) 942-0081
<http://www.everpure.com>

In Europe:
N.V. EVERPURE (EUROPE) S.A.
Geldenaaksebaan 478
B-3001 Heverlee
Belgium
Tel 32-16-401191
FAX 32-16-402691

In Japan:
EVERPURE JAPAN, INC.
1-8-19, Tsumada Kita,
1-Chome, Atsugi City
Kanagawa Ken 243-0812
Japan
Tel 81-462-23-6563
FAX 81-462-21-6775

Everpure, Inc.
2375 Sanders Road
Northbrook, IL 60062
Phone: 800-323-7873 Fax: 800-942-0081