

9060 HIGH VOLTAGE CONTROLLER (HV1—Automatic Guns)



MODEL: 80100-XXX

IMPORTANT: Before using this equipment, carefully read **SAFETY PRECAUTIONS**, starting on page 1, and all instructions in this manual. Keep this Service Manual for future reference.

Service Manual Price: \$50.00 (U.S.)

CONTENTS

	PAGE
SAFETY:	1-6
SAFETY PRECAUTIONS	1
HAZARDS / SAFEGUARDS.....	2-5
INTRODUCTION:	7-16
GENERAL DESCRIPTION.....	7
SAFETY FEATURES	7
DISPLAYS	7
SPECIFICATIONS	8
CONTROLLER FEATURES.....	9
OPERATOR INTERFACE.....	10
SWITCHES.....	10
LEDS	10
BUTTONS.....	10-11
CONNECTION INTERFACE.....	11
CONNECTORS.....	11-12
FUSES.....	12
SPARE FUSES.....	12
LOCAL/REMOTE BOARD	12
SIGNAL INTERFACE - LOCAL MODE	13
SIGNAL INTERFACE - REMOTE MODE.....	13-16
INSTALLATION:	17-28
GENERAL INFORMATION	17
LOCATION OF THE 9060.....	17
ELECTRICAL NOISE	18-19
I/O CONNECTIONS.....	19
AC INPUT CONNECTIONS	19-20
SAFETY GROUND	21
INPUT VOLTAGE SELECTION	21
INTERLOCKS.....	21-23
HIGH VOLTAGE CABLE.....	23
RELAY CONTACT OUTPUTS.....	23
LOCAL MODE SIGNALS	24-25
REMOTE I/O MODE SIGNALS	25-28
OPERATION:	29-42
START-UP	29
BASIC OPERATIONS.....	29-30
DI/DT CONFIGURATION.....	31

CONTENTS

	PAGE
OPERATION (Cont.):	29-42
LOCKOUTS	32-33
KV TEST JUMPER	33
REMOTE I/O MONITORING DIAGNOSTIC MODE	33-35
PARAMETER ADJUSTMENT MODE	35-36
LOCAL MODE ONLY OPERATIONS.....	36-37
REMOTE MODE ONLY OPERATIONS.....	37-39
FAULT DESCRIPTIONS	39-41
MAINTENANCE:	43-46
TROUBLESHOOTING GUIDE	43
FAULT TROUBLESHOOTING GUIDE.....	43-45
PARTS:	47-48
HIGH VOLTAGE CONTROLLER MODEL IDENTIFICATION	47
PARTS LIST	48
ACCESSORIES:	49
ACCESSORIES LIST.....	49
WARRANTY POLICIES:	50
LIMITED WARRANTY	50

Ransburg

SAFETY

SAFETY PRECAUTIONS

Before operating, maintaining or servicing any Ransburg electrostatic coating system, read and understand all of the technical and safety literature for your Ransburg products. This manual contains information that is important for you to know and understand. This information relates to **USER SAFETY** and **PREVENTING EQUIPMENT PROBLEMS**. To help you recognize this information, we use the following symbols. Please pay particular attention to these sections.

A WARNING! states information to alert you to a situation that might cause serious injury if instructions are not followed.

A CAUTION! states information that tells how to prevent damage to equipment or how to avoid a situation that might cause minor injury.

A NOTE is information relevant to the procedure in progress.

While this manual lists standard specifications and service procedures, some minor deviations may be found between this literature and your equipment. Differences in local codes and plant requirements, material delivery requirements, etc., make such variations inevitable. Compare this manual with your system installation drawings and appropriate Ransburg equipment manuals to reconcile such differences.

Careful study and continued use of this manual will provide a better understanding of the equipment and process, resulting in more efficient operation, longer trouble-free service and faster, easier troubleshooting. If you do not have the manuals and safety literature for your Ransburg system, contact your local Ransburg representative or Ransburg.



WARNING

- ▶ The user **MUST** read and be familiar with the Safety Section in this manual and the Ransburg safety literature therein identified.



- ▶ This manual **MUST** be read and thoroughly understood by **ALL** personnel who operate, clean or maintain this equipment! Special care should be taken to ensure that the **WARNINGS** and safety requirements for operating and servicing the equipment are followed. The user should be aware of and adhere to ALL local building and fire codes and ordinances as well as **NFPA-33 SAFETY STANDARD**, prior to installing, operating, and/or servicing this equipment.





WARNING

- ▶ The hazards shown on the following page may occur during the normal use of this equipment. Please read the hazard chart beginning on page 2.

AREA Tells where hazards may occur.	HAZARD Tells what the hazard is.	SAFEGUARDS Tells how to avoid the hazard.
<p>Spray Area</p> 	<p>Fire Hazard</p> <p>Improper or inadequate operation and maintenance procedures will cause a fire hazard.</p> <p>Protection against inadvertent arcing that is capable of causing fire or explosion is lost if any safety interlocks are disabled during operation. Frequent Controller shutdown indicates a problem in the system requiring correction.</p>	<p>Fire extinguishing equipment must be present in the spray area and tested periodically.</p> <p>Spray areas must be kept clean to prevent the accumulation of combustible residues.</p> <p>Smoking must never be allowed in the spray area.</p> <p>The high voltage supplied to the atomizer must be turned off prior to cleaning, flushing or maintenance.</p> <p>When using solvents for cleaning:</p> <p>Those used for equipment flushing should have flash points equal to or higher than those of the coating material.</p> <p>Those solvents used for cleaning must have a flash point at minimum of 5°C (9°F) greater than ambient temperature. It is the end users responsibility to ensure this condition is met.</p> <p>Spray booth ventilation must be kept at the rates required by NFPA-33, OSHA, and local codes. In addition, ventilation must be maintained during cleaning operations using flammable or combustible solvents.</p> <p>Electrostatic arcing must be prevented.</p> <p>Test only in areas free of combustible material.</p> <p>Testing may require high voltage to be on, but only as instructed.</p> <p>Non-factory replacement parts or unauthorized equipment modifications may cause fire or injury.</p> <p>If used, the key switch bypass is intended for use only during setup operations. Production should never be done with safety interlocks disabled.</p> <p>Never use equipment intended for use in waterborne installations to spray solvent based materials.</p> <p>The paint process and equipment should be set up and operated in accordance with NFPA-33, NEC, and European Health and Safety Norms.</p>

<p>AREA</p> <p>Tells where hazards may occur.</p>	<p>HAZARD</p> <p>Tells what the hazard is.</p>	<p>SAFEGUARDS</p> <p>Tells how to avoid the hazard.</p>
<p>Spray Area</p> 	<p>Fire and/or explosion.</p>	<p>Electrostatic arcing MUST be prevented.</p> <p>The 78789 control panel, LEPS5001 power supply and all other electrical equipment must be located outside Class I or II, Division 1 or 2 hazardous areas, in accordance with NFPA-33.</p> <p>Test only in areas free of flammable or combustible materials.</p> <p>The current overload sensitivity MUST be set as described in the OVERLOAD ADJUSTMENT Procedures section of this manual. Protection against inadvertent arcing that is capable of causing fire or explosion is lost if the current overload sensitivity is not properly set. Frequent power supply shutdown indicates a problem in the system which requires correction.</p> <p>Always turn the control panel off prior to flushing, cleaning, or working on spray system equipment.</p> <p>Ensure that the control panel is interlocked with the ventilation system and conveyor in accordance with NFPA-33, EN 50 176.</p> <p>Have fire extinguishing equipment readily available and tested periodically.</p>
<p>General Use and Maintenance</p> 	<p>Improper operation or maintenance may create a hazard.</p> <p>Personnel must be properly trained in the use of this equipment.</p>	<p>Personnel must be given training in accordance with the requirements of NFPA-33, EN 60079-0.</p> <p>Instructions and safety precautions must be read and understood prior to using this equipment.</p> <p>Comply with appropriate local, state, and national codes governing ventilation, fire protection, operation maintenance, and housekeeping. Reference OSHA, NFPA-33, EN Norms and your insurance company requirements.</p>

AREA Tells where hazards may occur.	HAZARD Tells what the hazard is.	SAFEGUARDS Tells how to avoid the hazard.
<p>Electrical Equipment</p> 	<p>High voltage equipment is utilized. Arcing in areas of flammable or combustible materials may occur. Personnel are exposed to high voltage during operation and maintenance.</p> <p>Protection against inadvertent arcing that may cause a fire or explosion is lost if safety circuits are disabled during operation.</p> <p>Frequent power supply shut-down indicates a problem in the system which requires correction.</p> <p>An electrical arc can ignite coating materials and cause a fire or explosion.</p>	<p>The power supply, optional remote control cabinet, and all other electrical equipment must be located outside Class I or II, Division 1 and 2 hazardous areas. Refer to NFPA-33 or EN 50 176.</p> <p>Turn the power supply OFF before working on the equipment.</p> <p>Test only in areas free of flammable or combustible material.</p> <p>Testing may require high voltage to be on, but only as instructed.</p> <p>Production should never be done with the safety circuits disabled.</p> <p>Before turning the high voltage on, make sure no objects are within the sparking distance.</p>
<p>Toxic Substances</p> 	<p>Certain material may be harmful if inhaled, or if there is contact with the skin.</p>	<p>Follow the requirements of the Material Safety Data Sheet supplied by coating material manufacturer.</p> <p>Adequate exhaust must be provided to keep the air free of accumulations of toxic materials.</p> <p>Use a mask or respirator whenever there is a chance of inhaling sprayed materials. The mask must be compatible with the material being sprayed and its concentration. Equipment must be as prescribed by an industrial hygienist or safety expert, and be NIOSH approved.</p>

AREA Tells where hazards may occur.	HAZARD Tells what the hazard is.	SAFEGUARDS Tells how to avoid the hazard.
<p>Spray Area / High Voltage Equipment</p> 	<p>There is a high voltage device that can induce an electrical charge on ungrounded objects which is capable of igniting coating materials.</p> <p>Inadequate grounding will cause a spark hazard. A spark can ignite many coating materials and cause a fire or explosion.</p>	<p>Parts being sprayed must be supported on conveyors or hangers and be grounded. The resistance between the part and ground must not exceed 1 megaohm. (Reference NFPA-33 or EN 50 176)</p> <p>All electrically conductive objects in the spray area, with the exception of those objects required by the process to be at high voltage, must be grounded.</p> <p>Any person working in the spray area must be grounded.</p> <p>Unless specifically approved for use in hazardous locations, the power supply and other electrical control equipment must not be used in Class 1, Division 1 or 2 locations or Class 1, Zone 0 for European Applications.</p>

NOTES

INTRODUCTION

GENERAL DESCRIPTION

The **Ransburg 9060 High Voltage Controller** (80100-XXX) is used to provide high voltage for electrostatic application equipment. It uses a combination of proven high voltage generation technology and microprocessor-based control. It uses a variable voltage output to drive a cascade that amplifies the voltage to a high kV level. It also uses current feedback information to maintain the desired set point. The processor circuitry provides the maximum in applicator transfer efficiency, while maintaining the maximum safety.

The 9060 Controller can operate in either LOCAL mode or REMOTE mode conditions. In the LOCAL mode, the selection and adjustment of set point values is performed from the controller front panel. The triggering of the HV in LOCAL mode is initiated by the optional airflow switch built into the controller (which senses airflow triggered by a standard handgun) or via a single discrete remote I/O trigger signal. In REMOTE mode, the selection and adjustment of the set point can be performed using either discrete or analog remote I/O signals. Two tripleset signals are provided that can be used to select one of the same three presets that are set and used in LOCAL mode. Two analog remote I/O set point signals are provided, one for current and one for voltage, and can be used to control the set point (See the Operation portion of this Manual for more information). The REMOTE mode triggering of HV is performed using a single discrete remote I/O trigger signal.

SAFETY FEATURES

When used with the appropriate applicators and cascades, the Ransburg 9060 High Voltage Controller provides maximized operational safety. The protections include detection of Ground Faults, Cable Faults, Feedback

Signal Faults, Overvoltage, and Overcurrent. The microprocessor circuits provide a controlled output load curve, which limits the high voltage output to safe levels while monitoring control and feedback signals for unsafe conditions. Maximum operational safety is obtained when the correct applicator settings are used and when safe distances between the applicator and target are observed and followed. The maximum efficiency of the high voltage controller is based on load.

DISPLAYS

The front panel displays the high voltage set point as well as a reading of the gun current output. The gun current is derived from feedback signals in the low voltage cable between the controller and the cascade.



Figure 1: 9060 High Voltage Controller

The 9060 High Voltage Controller (80100-XXX) is available as follows:

Part #:	Description
80100-21X	Non-Approved for use with Evolver SE
80100-31X	Atex Approved for use with Esta-Quick
80100-41X	Non-Approved for use with Evolver SE
80100-51X	Atex Approved for use with Aerobell 168

SPECIFICATIONS

Environmental

Operating Temperature: 0°C to +40°C

Storage and Shipping Temperature: -40°C to +85°C

(Allow power supply to go to room temperature before use)

Humidity: 95% Non-Condensing

Physical

Height: 16.5 cm (6.5 inches)

Width: 37.8 cm (14.9 inches)

Depth: 30.7 cm (12.1 inches)

Weight: 10.2 kg (22.5 lbs.)

Electrical

Input Voltage: 100-240 VAC

Frequency: 50 or 60 Hz

Current: 1 A max. RMS

Wattage: 40 watts (max.)

Output Voltage: 20-90kV MAX DC,
adjustable in
1kV increments

Ground: Use known good earth ground

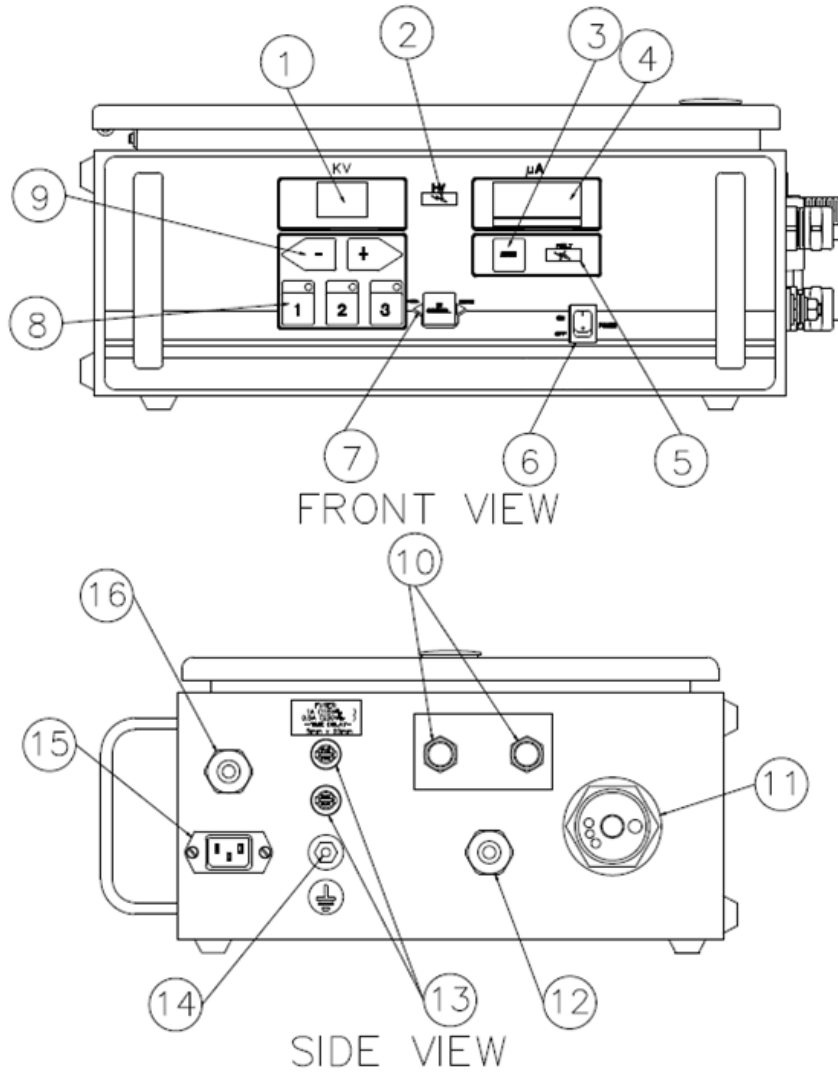

Figure 2: 9060 High Voltage Controller Features

9060 CONTROLLER FEATURES			
No.	Description	No.	Description
1	kV Display	9	kV Setpoint/Adjust Buttons
2	High Voltage On Indicator	10	Air Flow Switch Hose Connections
3	Reset Button	11	High Voltage Cable Connector
4	μ A Display	12	Standard I/O Connector
5	Fault Indicator	13	Fuses
6	On-Off Switch	14	Ground Lug
7	Local/Remote Mode Indicator	15	AC Inlet Receptacle
8	“One Touch” kV Setpoint Buttons	16	Interlock I/O Connector

OPERATOR INTERFACE

The 9060 Controller shown in Figure 3, has a simple operator interface consisting of 7 LEDs (Light Emitting Diodes), one (1) power switch, seven (7) buttons, one (1) current LED bargraph, and two (2) screens containing seven-segment displays.

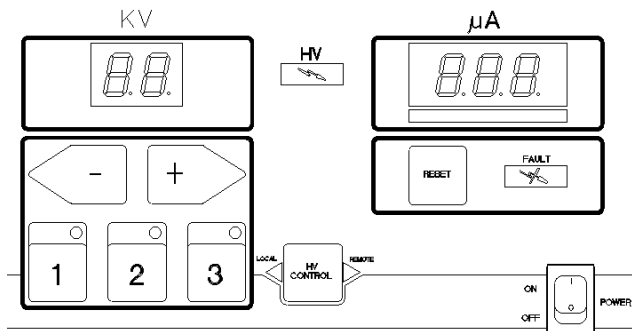

Figure 3: 9060 Operator Interface

SWITCHES

Power Switch

The 9060 Controller contains a single rocker switch for power On/Off selection. When the unit is powered on, the screens should be lit and display the gun display type information and the software version number for a short period of time.

LEDs

High Voltage On Indicator

The red High Voltage On Indicator is lit when a trigger signal has been received by the unit and the high voltage output from the cascade has been enabled.

Fault Indicator

The red Fault Indicator is lit when a fault occurs as determined by the microprocessor. When a fault occurs the light will turn on and the identification code (ID Code) for the fault will be displayed, blinking, on the μA meter display. For more information on the faults and fault ID codes, please refer the Fault Descriptions section in the Operations portion of this manual.

LOCAL Mode LED Indicator

The LOCAL mode LED indicator is a left pointing triangle and is located on the left side the HV control button on the center of the operator interface. This LED is lit when the Controller is in LOCAL mode.

REMOTE Mode LED Indicator

The REMOTE mode LED indicator is a right pointing triangle and is located on the right side the HV control button on the center of the operator interface. This LED is lit when the Controller is in REMOTE mode.

Active Preset LED Indicators (3)

The active preset LED indicators are located directly above each of the Preset Buttons. When a preset button is pushed to select the desired preset, in READY or RUN mode, the preset LED indicator directly above the button pressed will light up. Only one (1) preset light should be lit at any one time.

The preset LED indicators also have alternate meanings for the remote input/output (I/O) monitoring diagnostic mode. When in this mode, the preset LED indicators specify which diagnostic sub-mode is currently activated. For more information, please refer the remote input/output (I/O) monitoring diagnostic mode portion of the operations section of this service manual.

BUTTONS

The seven buttons on the operator interface are used to select the KV presets, reset overloads and faults, access other modes and to navigate as well as modify information that is displayed on the two seven-segment display screens (μA and kV).

The following lists the standard operating mode behavior for each button, for behaviors for other modes, please refer to the operation portion of this service manual for the specific mode.

Preset 1 Button

The Preset 1 Button (on the left below the kV display) is used by itself to select "Voltage Preset 1" in the normal operating mode. If

pressed with the reset button, at the same time, the screen will display the resettable High Voltage ON operating hours for 3 seconds on the display screens.

Preset 2 Button

The Preset 2 Button (in the center below the kV display) is used by itself to select “Voltage Preset 2” in the normal operating mode. If pressed with the reset button, at the same time, the screen will display the non-resettable High Voltage ON operating hours for 3 seconds on the display screens.

Preset 3 Button

The Preset 3 Button (to the right below the kV display) is used by itself to select “Voltage Preset 3” in the normal operating mode. If pressed with the reset button, at the same time, the system will enter the general diagnostic mode.

Left (-)/Right (+) Buttons

The left(-)/right(+) buttons in the normal operating mode are used to modify, decrease and increase respectively, the currently selected preset value. If the button is pressed and released, the preset value is changed by 1 kV at a time. If the button is held for over a 1/2 second, the value will begin changing by 5 kV increments.

Reset Button

The reset button is used in the normal operating mode to clear fault or overload conditions. This will NOT prevent any other active fault conditions from triggering a new fault.

HV Control Button

This button, shown in the center of Figure 3, is **not used** to perform mode changes. It is **reserved** for future use. The unit defaults to LOCAL mode. To enter REMOTE mode, a remote I/O signal input, local/remote mode selection, indicates when the unit should be in REMOTE mode. When this remote I/O signal is active, the unit will be in REMOTE mode, otherwise the unit will be in LOCAL mode.

CONNECTION INTERFACE

The 9060 Controller connection interface shown in Figure 4, provides all of the required connections for setting up either a remote I/O controlled painting system or a local controlled painting system. This connection interface consists of one (1) high voltage cable connector, one (1) standard I/O connector, one (1) interlock I/O connector, one (1) ground lug connection, one (1) air flow switch connection, two (2) fuses, and one (1) AC inlet receptacle.

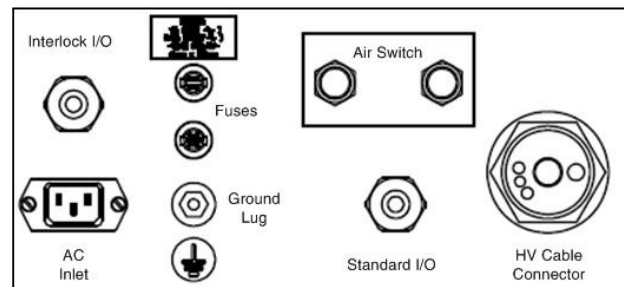

Figure 4: 9060 Connection Interface

CONNECTORS

High Voltage Cable Connector

The high voltage cable connector is the largest connector and is located on the far right of the connection interface. The connector will come covered with a factory installed red protective cap. This connector is designed for use with standard high voltage cables such as A10560, 79518, and 79519. The specific cable required depends on the applicator being used. Please refer to the applicator manual for the cable required.

Standard I/O Connector

The standard I/O connector is located just left of the high voltage cable connector. This connector is provided as the entry point for a shielded multi-conductor cable used for remote I/O signals and includes the required cable grommet hardware to keep the cable in place with minimal strain. For more information on remote I/O signal wiring, see the “Installation” section of the service manual.

Interlock I/O Connector

The interlock I/O connector is located just above the AC inlet receptacle. This connector is provided as the entry point for interlock signal wiring for the booth fan, conveyor, and solvent supply. The connector includes the required cable grommet hardware to keep wiring in place with minimal strain. For more information on the interlock connections, please see the “Installation” section of the service manual.

Ground Lug Connection

The ground lug connection is located directly below the fuses and has a ground logo sticker directly below it. This lug is provided as an external ground connection point used to ground the 9060 to an earth ground via a ground cable. This ground lug connection can also be used as the ground point for the high voltage cable ground.

Air Flow Switch Connection (Optional)

The air flow switch connection can be installed to provide a pneumatic trigger signal for hand-guns indicating that the trigger has been actuated. This signal is normally used for the “local” mode to turn on the High Voltage output. Both threaded connectors of the air flow switch, if installed, will come covered with red protected caps.

AC Inlet Receptacle

The AC inlet receptacle is a standard IEC C14 Appliance Inlet connector with a maximum rating of 250 VAC. It can handle both 110VAC and 240 VAC inputs at 50 or 60 Hz. The unit is shipped with the appropriate rated AC cord for the particular installation.

FUSES

Fuses

There are two (2) time delay fuses (250V, 1A, 5mm x 20mm) installed in fuse holders on the connection interface. They are located directly above the ground lug connection. They are present to provide a measure of safety against power surges through the AC input. The top fuse holder is connected in series between the

HOT line (L) input connection and the Interlock AC line connection terminal 1TB-L2. The bottom fuse holder is connected in series between the neutral AC input connection and the neutral input connection of the AC line power filter.

Spare Fuses

The Controller also comes with two (2) spare fuses (250V, 1A, 5mm x 20mm) mounted in holders, inside the lid of the Controller.

LOCAL/REMOTE BOARD

The 9060 Controller contains a local/remote trigger protection board that is used to protect against trigger signals from falsely triggering the High Voltage when the unit is not in the desired operating mode. As the 9060 Controller was designed to operate in both LOCAL or REMOTE mode, it must be configured for the desired mode of operation.

If configured for LOCAL mode, the local/remote board has jumpers set in a “bypass” mode that prevents the unit from being put into REMOTE mode. The trigger signal input can directly activate high voltage.

If configured for REMOTE mode, the local/remote board has jumpers set so that the trigger signal routing is controlled by the local/remote mode signal. If the local/remote signal is off, the unit will be placed in LOCAL mode and the high voltage is disabled. This allows the user to safely adjust the voltage presets. If the local/remote signal is on, the unit will be placed in REMOTE mode and the trigger signal will activate the high voltage.

NOTE

➤ A slight delay, 300 milliseconds, is imposed between mode changes and the high voltage from being activated. This is to prevent a trigger signal that may already be present from instantly turning on the high voltage when a mode change occurs.

SIGNAL INTERFACE - LOCAL MODE

The 9060 Controller LOCAL mode is normally used for handguns, or very simple automatic gun systems. Handguns require only one signal input for operation, the trigger signal. Though not necessary for operation, there are also two (2) output relay contact signals, HV on and Fault, that can be useful for triggering remote devices such as lights or other safety indicators. The physical signal interface is provided via the 2 terminal blocks, 2TB and 3TB.

Trigger Signal

The trigger signal input (3TB-5) is a signal shared between the LOCAL and REMOTE modes. Due to this, this input must be configured for either LOCAL or REMOTE mode prior to operation. This signal can be configured as either a sourcing or a sinking signal. Please refer to the "Installation" section of this service manual for LOCAL mode configuration information.

High Voltage On (Relay Output, Dry Contact)

The "HV on" signal (2TB-4) is available in both LOCAL and REMOTE modes. This signal, being a relay controlled signal, can be configured as either an AC or DC signal using the Relay Common Input as the signal source. For information regarding the relay contact voltage ratings, please refer to the "Relay Output Contacts" portion of the "Installation" section of the manual. This relay signal is activated when the High Voltage cascade is turned on.

Fault (Relay Output, Dry Contact)

The "Fault" signal (2TB-2) is available in both LOCAL and REMOTE modes. This signal, being a relay controlled signal, can be configured as either an AC or DC signal using the Relay Common Input as the signal source. For information regarding the relay contact voltage ratings, please refer to the "Relay Output Contacts" portion of the "Installation" section of the manual. This

relay signal is activated when a Fault Condition or Overload Condition has faulted the 9060 Controller.

Relay Common Input

The relay common input (2TB-3) is a shared connection between the Fault and HV on relay outputs. This is the source of their output voltage. It can be wired to either an AC or DC signal. It is most commonly connected to the 24 VDC power provided at (2TB-1). This allows the relays to output 24 VDC signals without the use of any outside power sources.

SIGNAL INTERFACE - REMOTE MODE

The REMOTE mode is designed for use with automatic applicators such as the Estaquick and Evolver SE where the control of the applicator and Controller are driven by an external control system using discrete analog and digital I/O. For example, a programmable logic controller (PLC), can be used as the control system. The physical signal interface is provided via the 2 terminal blocks, 2TB and 3TB.

The 9060 High Voltage Controller remote mode signal interface is composed of five (5) digital inputs, two (2) analog inputs, two (2) relay contact outputs (AC or DC), and one (1) analog output. For information on how to correctly install the wiring for the remote signal interface please refer to the "Installation" section of this service manual. The following section describes all of the remote I/O signals.

Digital Inputs

All of the digital inputs on the 9060 High Voltage Controller are 24 VDC signals that can be configured as either sourcing or sinking inputs. For information regarding configuring the inputs, refer to the "Installation" section of this manual.

Local/Remote Mode Signal

The local/remote mode signal (3TB-2) indicates to the 9060 Controller whether the system is currently in LOCAL mode or REMOTE mode. If the signal is off, the system will be in LOCAL mode. If the signal is on, the system will be in REMOTE mode.

Reset Signal

The reset signal (3TB-1) will reset any fault or overload condition that has occurred. It will **NOT** prevent any other existing fault conditions from re-faulting the system immediately after resetting. Please refer to the “Operation” section of this service manual for fault reset and troubleshooting information.

Remote Trigger Signal

The remote trigger signal (3TB-5) is used to indicate to the 9060 Controller to turn on the high voltage. This signal connection is routed to the main PC board connector J3-5. Input J3-5 is the same signal input that is used in LOCAL mode triggering. Due to this, the local/remote trigger protection board (Assy# A13123) is present for trigger control.

Tripleset 1 and Tripleset 0 (TS1 and TS0)

The tripleset signals, TS1 and TS0 (3TB-3 and 3TB-4), are a pair of signals that are used to select one of the three preset voltages that are normally selected during LOCAL mode operation via the three preset buttons on the left side of the front panel. The two signals are used together as a binary number to select the corresponding preset value. The selected preset value will not change unless a different preset value is input. The binary combinations and their resulting selection are listed in the Triple Set Combinations table.

Triple Set Combinations		
TS1	TS0	Selection
0 (off)	0 (off)	No Change
0 (off)	1 (on)	Preset 1
1 (on)	0 (off)	Preset 2
1 (on)	1 (on)	Preset 3

NOTE

► The tripleset signals can be used to select a preset from the three (3) preset voltages. The preset values can **NOT** be adjusted from REMOTE mode. To adjust the preset values stored in the 9060, the unit **MUST** be in LOCAL mode. If the voltage setpoint must change between more than 3 values, one of the analog KV setpoint signals should be used.

Analog Inputs

Two (2) analog input signals, along with an analog common input, are provided on the 9060 High Voltage Controller for analog control the KV setpoint value. One signal is provided for analog control using a voltage signal, the other for a current signal. The analog inputs are intended for applicator systems that require either more than 3 presets or an adjustable setpoint voltage.

Analog Setpoint Control

The analog control signals are the dominant setpoint control signals. When one of the signals is present, it will override control of the set point as soon as the minimum analog signal value is reached. The minimum signal required to override setpoint control is the value equivalent to approximately 20 kV. After reaching the minimum signal, the control signal can be adjusted between the minimum and the maximum for the control signal being used (current or voltage). The 9060 Controller automatically truncates the maximum setpoint value to the maximum voltage value for the applicator being used.

Any control signal increases that would push the setpoint beyond this value will have no effect. This is done to protect the applicator from adverse damage.

Analog Voltage Signal

The analog voltage signal (3TB-7) is an input control signal that adjusts the KV setpoint scaled relative to the voltage signal applied. The allowable range for the voltage control signal is 0-10V. The minimum signal required to override the KV setpoint control is 2.0V.

Analog Current Signal

The analog current signal (3TB-6) is an input control signal that adjusts the KV setpoint scaled relative to the current signal applied. The allowable range for the current control signal is 0mA-20mA, with the minimum required to override the KV setpoint being 4mA.



WARNING

► **DO NOT** attempt to use both analog voltage and analog current at the same time. The analog inputs are **mutually exclusive**. Using both inputs simultaneously **will damage** the input circuit. Only one analog input, current or voltage, can be used at time to control the setpoint value.

Analog Common Signal

The analog common signal (3TB-8) is the connection for the common reference (-) of the analog signal source. It is used as the common for both the voltage and current signal.

NOTE

► Although the allowable range for the analog current signal does include 0mA-3mA, it will normally be listed as 4-20mA as the 0-3mA portion of the range is insufficient to override KV setpoint control.

Analog Output

The 9060 High Voltage Controller provides a single analog output signal that can be used for monitoring the current output. This output can be used for simple monitoring or it can be used by the control system to allow for closed loop analog setpoint adjustment.

Analog Current Signal

The analog current signal (3TB-9) is a scaled version of the actual feedback current. The real feedback current is in μA where as the current signal provided at 3TB-9 is in mA to make it easily integrated with common systems like PLCs.

Relay Contact Outputs

The relay contact outputs are the HV On and Fault outputs that were previously described in the Signal Interface - Local Mode section. Their descriptions are duplicated here for completeness.

High Voltage On (Relay Output, Dry Contact)

The "HV on" signal (2TB-4) is available in both LOCAL and REMOTE modes. This signal, being a relay controlled signal, can be configured as either an AC or DC signal using the Relay Common Input as the signal source. For information regarding the relay contact voltage ratings, please refer to the "Relay Output Contacts" portion of the "Installation" section of the manual. This relay signal is activated when the High Voltage cascade is turned on.

Fault (Relay Output, Dry Contact)

The "Fault" signal (2TB-2) is available in both LOCAL and REMOTE modes. This signal, being a relay controlled signal, can be configured as either an AC or DC signal using the Relay Common Input as the signal source. For information regarding the relay contact voltage ratings, please refer to the "Relay Output Contacts" portion of the "Installation" section of the manual. This relay signal is activated when a Fault Condition or Overload Condition has faulted the 9060 Controller.

Relay Common Input

The relay common input (2TB-3) is a shared connection between the Fault and HV on relay outputs. This is the source of their output voltage. It can be wired to either an AC or DC signal. It is most commonly connected to the 24 VDC power provided at (2TB-1). This allows the relays to output 24 VDC signals without the use of any outside power sources.

N O T E S

INSTALLATION

GENERAL INFORMATION

The following section contains general information on the installation of both local and remote systems using the 9060 High Voltage Controller.



WARNING

- ▶ The 9060 Controller **MUST** be located outside of the hazardous area.
- ▶ The User **MUST** read and be familiar with the “Safety” section of this manual.
- ▶ This manual **MUST** be read and thoroughly understood by **ALL** personnel who operate, clean, or maintain this equipment! Special care should be taken to ensure that the warnings and requirements of operating and servicing safely are followed. The user should be aware of and adhere to **ALL** local building and fire codes and ordinances as well as NFPA-33, OSHA, and all related country safety codes prior to installing, operating, and/or servicing this equipment.
- ▶ Only approved applicators should be used with the 9060 High Voltage Controller.

NOTE

- ▶ As each installation is unique, this information is intended to provide general installation information for the 9060 Controller. Consult your authorized Ransburg distributor for specific directions pertaining to the installation of your equipment.

LOCATION OF THE 9060

Install the Controller in an area **outside the hazardous location** in accordance with federal, state, and local codes. The area should protect the Controller from the possibility of environmental intrusion (such as dust or moisture), have ambient temperatures that do not exceed 40°C, and be as close to the applicator as possible to minimize the length of the high voltage cable.



CAUTION

- ▶ **DO NOT** locate the Controller near or adjacent to heat producing equipment such as ovens, high wattage lamps, etc.

The Controller may be free standing on any flat surface or wall mounted (wall mount brackets not supplied) as shown in Figure 5.

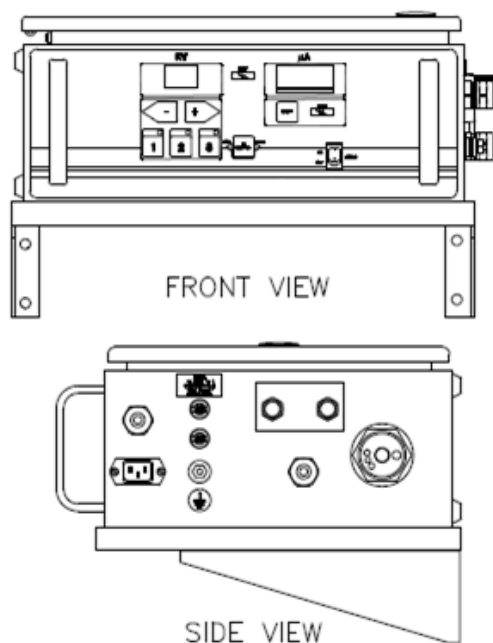

Figure 5: Typical Controller Mounting

ELECTRICAL NOISE

Electrical noise refers to stray electrical signals in the atmosphere at various signal strengths and frequencies that can affect the operation of equipment. One of the best ways to prevent this is to shield the equipment and cables within a **continuous** ground envelope, such that any incident noise will be conducted to earth ground before it can affect the circuit conductors.

For conductors inside the control unit or Controller, the grounded enclosures provide this envelope. For the cables that connect the applicator to the control unit or Controller, a shielded cable has been used. The shield consists of an overall foil shield in combination with an overall braided shield. This provides the most effective shielding, as the foil covers the "holes" in the braid, and the braid allows for practical 360° termination at both ends of the cable.

The AC input cord is not shielded, but is directed to an AC line filter as soon as it enters the cabinet. This method filters out most of the noise that comes in on the AC line. For maximum noise immunity, if the AC line is wired using conduit instead of the provided AC line cord, it should connect to the filter as soon as it enters the cabinet with as short of leads as possible. Additional noise protection can be provided by running the AC input line to the control panel in grounded conduit.

For maximum noise protection any user supply input/output (I/O) wiring should be made using shielded cable (or conduit) which is connected to earth ground in a continuous 360° fashion at both ends. The best way to do this is to use a connector (conduit fitting) at each end of the cable (conduit) that makes contact to the shield (conduit) in a full 360° circle around the cable (conduit) and makes contact to the grounded enclosure in the same fashion. Connecting the drain wire of a shield to a ground point on or in the cabinet (usually referred to as pigtailing) is not an effective method of shielding and actually makes things worse (see Figure 6).

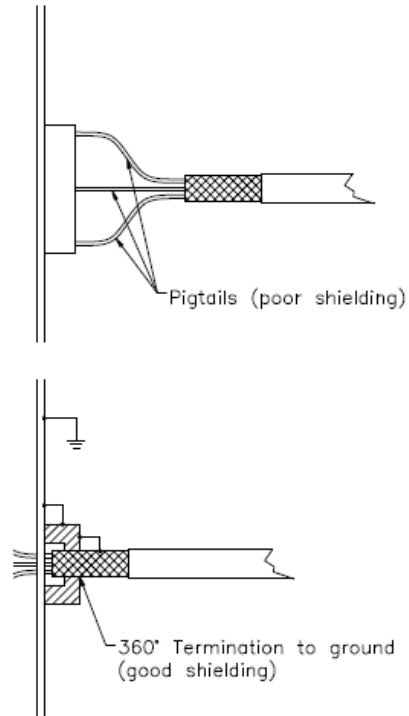

Figure 6: Pigtailing Connection

It is recommended that all AC I/O (interlocks) be run in conduit. If desired and codes permit, cabling may be used for these signals, but for maximum noise immunity the cabling must contain overall foil and braided shields and be terminated as described in the preceding paragraph.

Cable is recommended for all of the analog and digital remote I/O control signals including the relay controlled DC I/O (high voltage output signal, fault output signal). Again, for maximum noise immunity the cabling must contain overall foil and braided shields and be terminated in a continuous 360° manner as described in the preceding paragraph. Special fittings have been provided on the control panel for termination of these cables at that point. The use of these fittings is described in the corresponding sections of this manual.

Using the methods previously described, the 9060 Controller have been successfully tested to the stringent standards of the Electromagnetic Compatibility Directive of the European Union. The results conclude that these units are neither a source of electrical noise nor

affected by electrical noise when the above methods are utilized.

I/O CONNECTIONS

For maximum noise immunity, I/O wiring should be run in conduit or cables having a foil shield with an overall braided shield. The foil shield provides 100% shielding, while the braid provides a means of making proper 360° shield terminations at the cable to cabinet connection points. To make I/O connections using shielded cable, perform the following:

1. Remove the cable grommet hardware from the desired I/O connector housing (See Figure 7).
2. Route the desired length of I/O cable through the connector housing and mark 1" span of cable that passes through the connector housing to be stripped to braid (See Figure 8).
3. Remove cable and strip marked 1" section to cable braid.
4. Slide the cable grommet hardware onto the cable in the order shown in Figure 7.
5. Route the cable back through the connector housing and connect its wires to the desired I/O terminals inside the 9060 Controller.
6. Tighten the cable grommet ensuring the grommet spring makes 360° contact with the exposed braid of the cable, for maximum noise immunity.
7. For maximum noise immunity, connect the braid of the cable to earth ground at the end opposite the Controller.

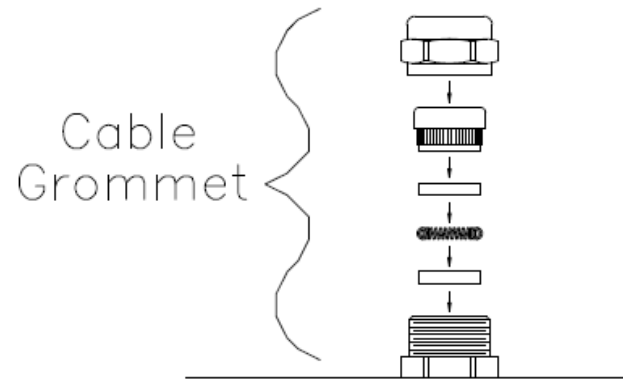

Figure 7: Cable Grommet

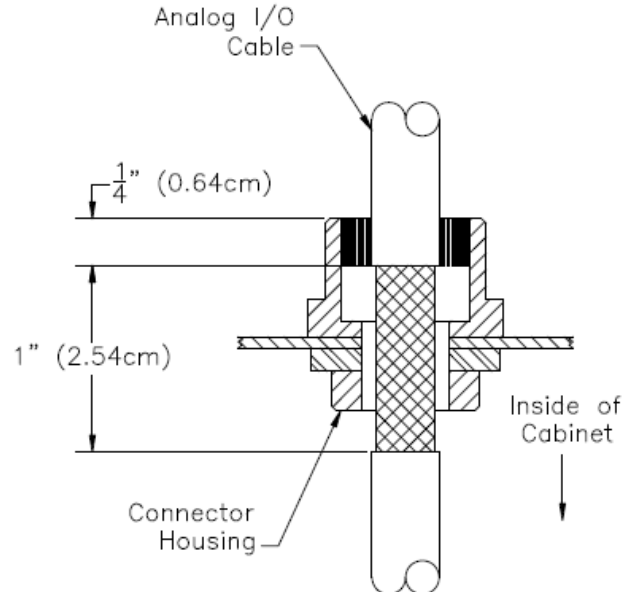

Figure 8: I/O Cable Stripping

AC INPUT CONNECTIONS

For non-conduit installations, plug the detachable AC line cord into the receptacle on the side of the 9060 Controller. Plug the other end of the line cord into a properly grounded 110 volt AC outlet.

NOTE

► In general, conduit must be used for approved AC installation, however, if national and local codes permit, the AC power may be supplied via the factory supplied line cord. If conduit is utilized, the Controller AC input wiring may be routed through an optional explosion proof switch mounted on or near the spray booth where it will be convenient to the operator.

For installations where it is required to run the AC input wiring in conduit, perform the following:

1. **Ensure the AC line cord is unplugged** and remove the AC inlet receptacle wiring from TB1-N, TB1-L1 and TB1-EARTH GROUND (See Figures 9 and 10).
2. Remove the mounting hardware from the AC inlet receptacle and remove it from the side of Controller.
3. Install the Conduit Adapter Plate (supplied) in the hole where the AC inlet receptacle was removed (see Figure 11).
4. Install the AC input wiring (0.8mm² (18AWG) minimum) through the Conduit Adapter Plate using conduit and wire to TB1 as follows:

Hot/Line	to TB1-L1
Neutral/Common	to TB1-N
Ground	to TB1-EARTH GROUND

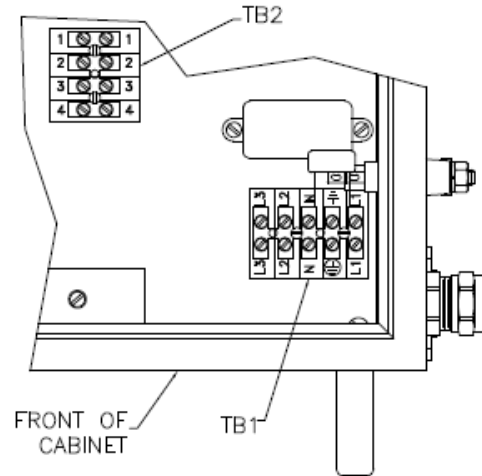

Figure 9: Location of TB1 & TB2 in Controller

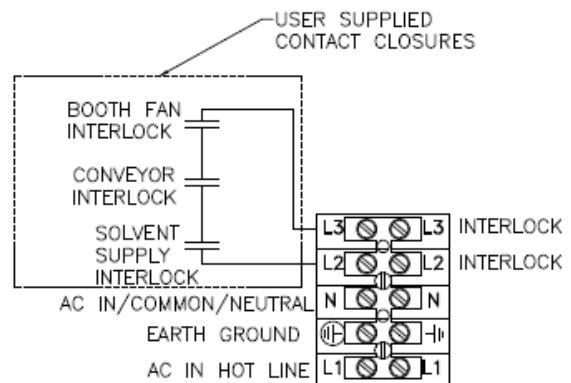

Figure 10: TB1 Interlock Wiring

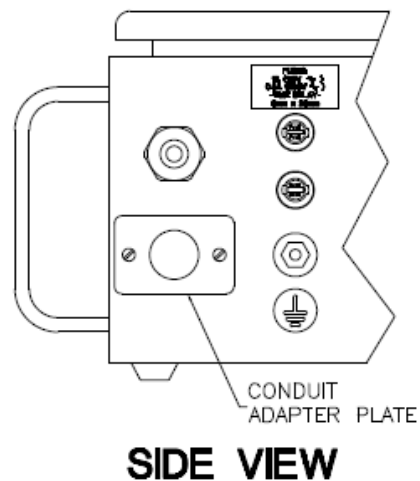

Figure 11: Installation of Conduit Adapter Plate

SAFETY GROUND

Crimp the appropriate connector onto the ground wire assembly and install from the Controller ground stud, located on the side panel, to a true earth ground.



CAUTION

► The ground wire assembly **MUST** be connected from the Controller ground stud to a true earth ground.

INPUT VOLTAGE SELECTION

The 9060 Controller accepts universal input voltage between 100 and 240 VAC at 50 or 60 Hz. There is no need to change any switch settings when changing input from 110 to 240 VAC or from 240 to 110 VAC.

NOTE

► **All 9060 units** (80100-XXX) shipped from the factory for either 110 VAC input or 240 VAC input will have a 72771-06, 1 Amp front panel fuses installed.

INTERLOCKS

Interlocks required by code are as follows:

- Booth Fan Interlock - When the booth fan is on, a contact closure is made.
- Conveyor Interlock - When the conveyor is moving, a contact closure is made.
- Solvent Interlock - When solvent supply to the applicator is off, a contact closure is made.



WARNING

► Failure to connect interlocks could result in a fire or explosion.



WARNING

► **ALWAYS** ensure that high voltage is **OFF** before flushing the spray applicator with solvent. **NEVER** flush the spray applicator with high voltage **ON**, as this is a severe fire hazard and risk to personnel safety. It is recommended that the high voltage control be interlocked with the solvent flush signal so that high voltage is automatically locked out whenever flushing occurs. Consult your authorized Ransburg representative for information on interlocking the high voltage **OFF** signal with the solvent flush signal.

As outlined in NFPA-33, OSHA, and EN 50176, the AC power line must be series interlocked with both the exhaust fan and conveyor.

To install the Controller interlocks perform the following:

1. Turn the 9060 Controller off, disconnect it from its AC source, and remove the fuses.



WARNING

► **ALWAYS** double check that the Controller is **unplugged from its AC outlet** before working with any internal wiring.

3. Using a small blade screwdriver, remove the factory installed test jumper from TB1-L2 to TB1-L3.
4. Using a shielded cable for the interlock wiring (supplied by user), route through the interlock connector on the side of the 9060 Controller and terminate TB1-L2 and TB1-L3 as shown in Figure 10 and 12. The shielded cable must have a minimum rating

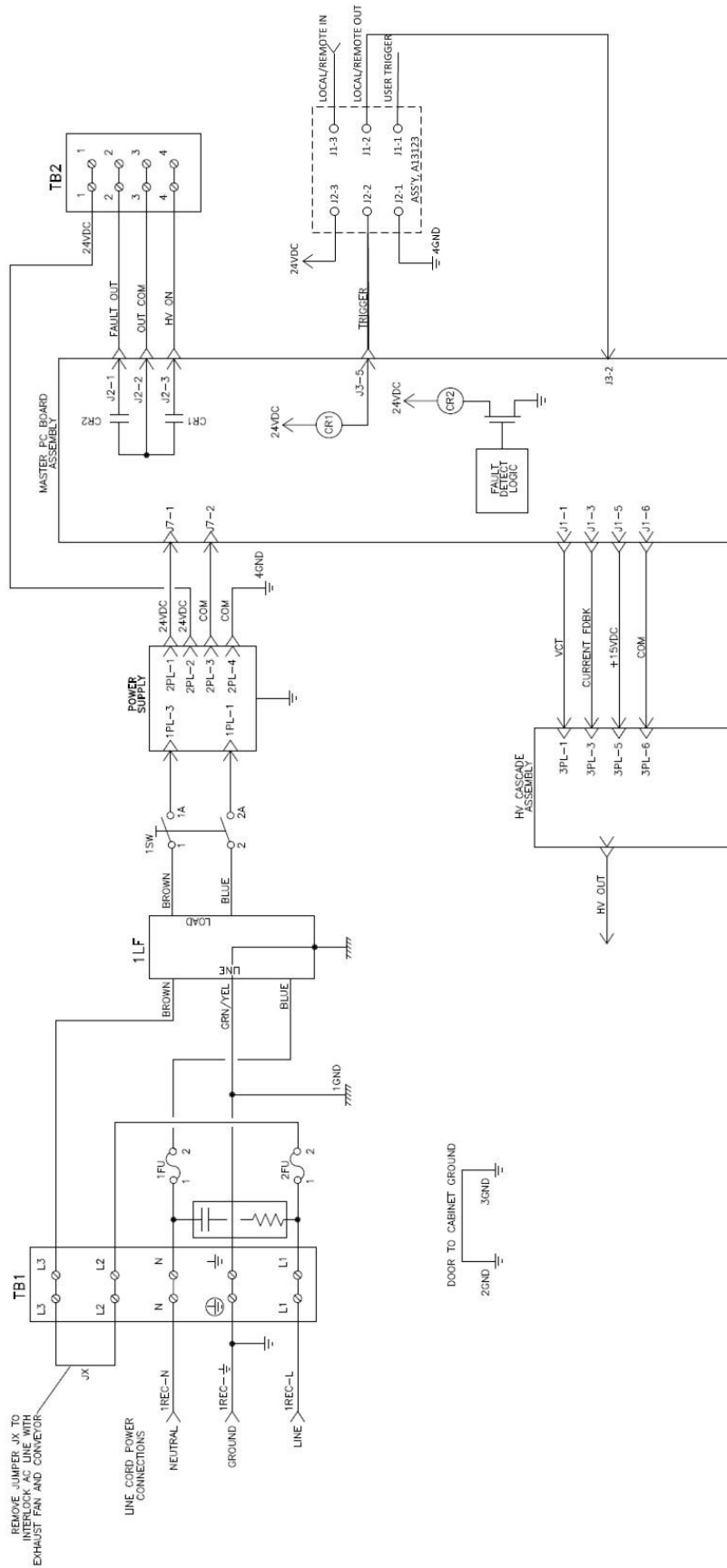

Figure 12: Controller Schematic

of 300V and 105°C and its conductors should be 0.8mm² (18 AWG) minimum. Secure the cable to the interlock connector as described in “I/O Connections” in the “Installation” section of this manual so that the shield of the cable is connected to the chassis of the enclosure.

- Secure the cabinet door, replace the fuses, and reconnect the AC source.

NOTE

► Some codes may require the interlock wiring to be run in conduit. In this case, shielded cable is not necessary, but the conductors used should still meet the rating specified above.

NOTE

► The interlock contacts (supplied by user) should be rated for at least 1 amp at 240 VAC.

NOTE

► The total resistance of the series interlocks between L2 and L3 should be less than 300 Ω.

HIGH VOLTAGE CABLE

Position the spray applicator in the spray area and route the high voltage cable to the Controller. The cable should be routed so that it is not damaged by foot and vehicle traffic and also so that is not close to areas of high temperature (129°F+). The operator should have free movement of the applicator and all bend radii of the cable should not be less than 6-inches (15 cm). Connect the high voltage cable to the Controller and tighten the retaining nut and set screw. If during the routing of the high voltage cable it is required to remove it from the spray applicator, care should be taken when re-installing so that the high voltage cable is completely engaged.



WARNING

► The Controller **MUST** be **OFF** when the applicator is removed or reinstalled.

RELAY CONTACT OUTPUTS

A set of relay contacts for high voltage (CR1) and fault (CR2) conditions is provided at 2TB-4 and 2TB-2 (See Figure 9). One end of these relay contacts are connected together and also connected to a source input terminal 2TB-3 (See Figure 12). When a source voltage is present at 2TB-3 and either the high voltage is on or a fault condition occurs, the source voltage will become available at the output end of the corresponding contact. Maximum contact ratings are as follows:

MAXIMUM CONTACT RATINGS

Description	DC	AC
Max. Switching Capacity	60W	62.5VA
Max. Operating Voltage	125VDC	125VAC
Max. Operating Current	2A	2A

When wiring to 2TB, use a shielded cable and route the wiring through the standard I/O connector as described in the “I/O Connectors” section of this manual.

NOTE

► An internal 24 VDC source voltage is available at 2TB-1. Using a jumper wire, this voltage may be connected to 2TB-3 to be used as the source voltage for the relay contact outputs. In this case, the total current sourced should not exceed 1 amp.

LOCAL MODE (TRIGGER SIGNAL ONLY)

The LOCAL mode is normally used only for handguns, or very simple automatic gun systems. Most handguns use a flow switch (13742-01 or 13742-02) to provide the trigger signal. The listed flow switches can be mounted inside the 9060 Controller chassis via the Air Flow Switch Connector on the side panel. When the handgun trigger is pressed and flow starts, the flow switch is activated and triggers the high voltage. Due to this, only a single trigger signal input is required to operate in LOCAL mode. As the 9060 Controller is designed to operate in both REMOTE and LOCAL modes, it contains all of the wiring connections for both modes and requires some minor setting changes to allow operation in LOCAL mode using only the trigger input signal.

To operate the Controller in the LOCAL mode, which uses only the high voltage trigger signal, perform the following:

1. **Turn the 9060 Controller off, disconnect it from its AC source, and remove the fuses.**
2. Open the Controller cabinet door.

! WARNING

➤ **ALWAYS** double check that the Controller is **unplugged from its AC outlet** before working with any internal wiring.

3. If the flow switch is being used, connect the ground (green) lead from the flow switch to the ground screw on the base plate shown in Figure 13. The trigger signal (blue) lead should be connected to the trigger signal on the remote I/O terminal block connector (Position 5) as shown in Figure 14.

! WARNING

➤ The 9060 High Voltage Controller is designed to handle both a sinking or sourcing trigger input.

➤ **DO NOT** use a sourcing trigger signal with the 9060 jumpers set for sinking inputs or vice versa. Sourcing and sinking inputs have different current flow paths. Using the wrong settings for the wrong type input can have unexpected behavior and/or cause damage to the input circuits.

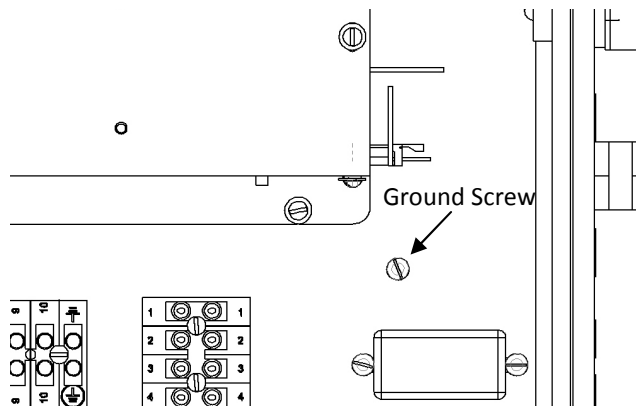

Figure 13: Ground Screw on Base Plate

NOTE

➤ The standard air flow switch (13742-01 or 13742-02) used in the 9060 is wired as a **sinking** switch. When the flow switch is activated, it connects the trigger signal input to ground. This requires that the local/remote trigger protection board be setup to accept a **sinking** input. If sourcing inputs are needed, the flow switch ground wire must be changed to a 24V DC connection (available on the terminal blocks).

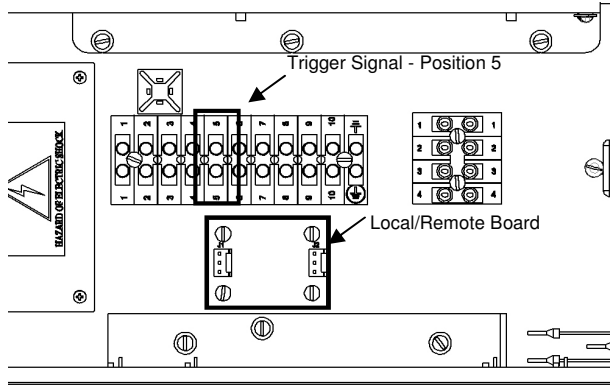

Figure 14: Remote I/O Signal Terminal Block

NOTE

► If a different switch is being used for the trigger signal, read the switch documentation for the wiring instructions for the specific switching element. Verify whether sinking or sourcing is to be used so the local/remote trigger protection board jumpers are set correctly. For further information, consult your authorized Ransburg distributor for specific directions pertaining to your installation or call Customer Service.

- The local/remote board (Assy# A13123), shown in Figure 14 at the bottom below the remote I/O signal terminal block, is designed for trigger protection in REMOTE mode. It must have the jumpers adjusted into "bypass position" to allow for LOCAL mode operation for the desired input type. The location of the jumpers on the board is displayed in Figure 15. Use the LOCAL mode jumper settings table for the jumper settings based upon your specific input.

LOCAL Mode Jumper Settings		
Jumper	Local Source	Local Sink
JMP1	1-3	1-3
JMP1	2-4	4-6
JMP2	2-3	1-2

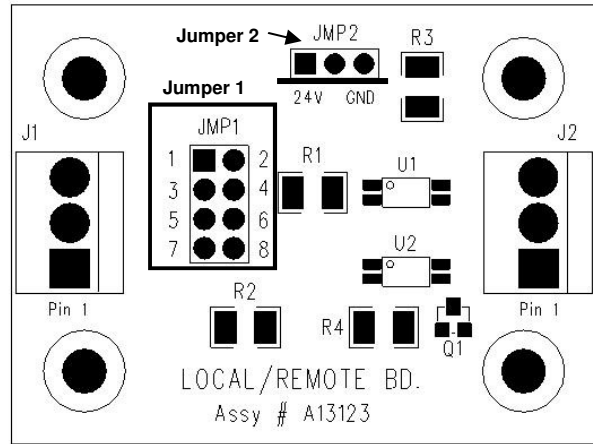

Figure 15: Local/Remote Board Jumper Headers

- Secure the cabinet door, replace the fuses, and reconnect the AC source.

For any installation that includes a trigger signal that is generated by a switch or source that is external to the 9060 Controller unit, the signal should be routed in through the standard I/O connector using a shielded cable (supplied by user). Secure the cable to the standard I/O connector as described in "I/O Connections" in the "Installation" section of this manual so that the shield of the cable is connected to the chassis of the enclosure.

REMOTE MODE EXTERNAL SIGNALS

The REMOTE mode is designed for use with automatic applicators such as the Estaquick and Evolver SE where the control of the applicator and Controller are driven by a external control system using discrete analog and digital I/O. For example, a programmable logic controller (PLC), can be used as the control system.

There can be up to thirteen (13) or more signal wires present depending on the signals that are intended to be used by the control system. More wires may be needed depending on the number of power and ground lines required for any particular installation.

The Relay Contact Outputs are normally included as output signal indicators for a control system and are wired using a few of the conductors in the I/O cable. For more information about the Relay Contact Outputs wiring, please refer to the prior “Installation” section on that topic.

A complete description of all of the signals available in remote mode is provided in the “Introduction” section of this service manual. For more information on the behavior or timing requirements for any of the signals, please refer to the “Operations” section of this service manual.

NOTE

➤ **Before** performing any wiring, verify the number of I/O signals, supply, and ground lines that will be required and select a shielded I/O cable that has at least that many lines.

➤ **Create a table** of I/O signals to conductor wire color. Including the terminal block location in this table is also helpful for reference.

➤ **Locate** all of the required signal terminal connections in advance to determine the amount of wire length required.

➤ It is better to connect no more than two (2) conductors into any single terminal block connection.

To operate the Controller in the REMOTE mode using any number of the discrete I/O signals, perform the following:

1. **Turn the 9060 Controller off, disconnect it from its AC source, and remove the fuses.**
2. Open the Controller cabinet door.



WARNING

➤ **ALWAYS** double check that the Controller is **unplugged from its AC outlet** before working with any internal wiring.

3. Route the selected shielded cable through the standard I/O connector and secure it to the connector as described in “I/O Connections” in the “Installation” section of this manual so that the shield of the cable is connected to the chassis of the enclosure. Ensure that enough wire length is available to allow for proper wiring of all of the I/O signals.
4. Connect the conductors to the respective remote I/O signal locations. Screw down the terminal block screws to secure the conductors in place. The I/O Signal Locations table contains the complete list of all I/O, ground, and 24VDC supply locations as well as their normal voltage/current values. The locations of the I/O terminal blocks are shown in Figure 16.

I/O Signal Locations

Signal	Terminal Block	Normal Value
24 VDC	2TB-1, 3TB-10	24VDC
Fault	2TB-2	24VDC
Relay Common	2TB-3	24VDC via JTB-1
HV On	2TB-4	24VDC
Reset	3TB-1	24VDC or GND
Local/Remote	3TB-2	24VDC or GND
Tripleset 1 (TS1)	3TB-3	24VDC or GND
Tripleset 0 (TS0)	3TB-4	24VDC or GND
Trigger	3TB-5	24VDC or GND
Analog Current	3TB-6	0-20mA
Analog Voltage	3TB-7	0-10V
Analog Common	3TB-8	Ground (0V)
Analog Feedback Current	3TB-9	0-200mA
Ground	3TB-10, Ground Lug	Ground (0V)

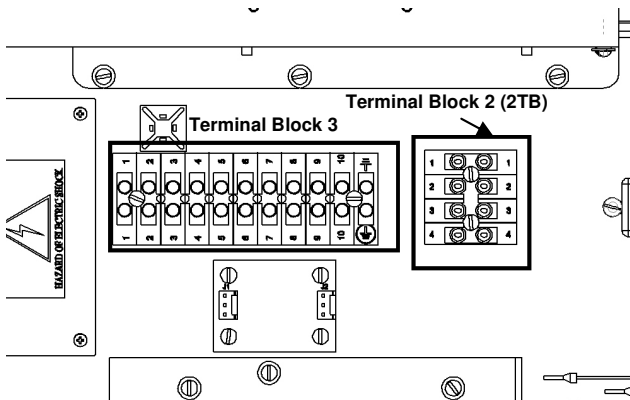

Figure 16: I/O Terminal Block Locations

NOTE

➤ After securing the conductors to the terminal blocks positions, it is best to perform a continuity test between the terminal block screw and the opposite end of the shielded cable for each conductor to ensure a good connection has been made with each conductor. Also a 2 finger pull test should be done. Pull on each conductor with 2 fingers to ensure it is tight.

- Determine whether the digital signals will be configured as sinking (grounding input) or sourcing (powering input).

NOTE

➤ **All** of the digital inputs, including the trigger signal, **MUST** be configured as either all sourcing or all sinking. The trigger signal is configured through the local/remote trigger protection board jumper settings.



WARNING

➤ **DO NOT** use a sourcing signal with the 9060 jumpers set for sinking inputs or vice versa. Sourcing and sinking inputs has different current flow paths. Using the wrong settings for the wrong type input can have unexpected behavior and/or cause damage to the input circuits.

- The local/remote board (Assy# A13123), jumpers must be adjusted into one of the two REMOTE settings, based on the desired input type, to allow for REMOTE mode operation. The location of the jumpers on the board is displayed in Figure 15. Use the REMOTE mode jumper settings table for the jumper settings based upon your specific input.

REMOTE Mode Jumper Settings

Jumper	Remote Source	Remote Sink
JMP1	3-4	3-4
JMP1	5-7	5-7
JMP2	2-3	1-2

- Set the main PC board sink/source jumper (J5) for the rest of the digital I/O signals. The location of this jumper is shown in Figure 17. Set the jumper the correct pins for the desired input type as listed in the following table.

PC Board Jumper 5 Settings

Mode	Jumper Pins
Sinking	1-2
Sourcing	2-3

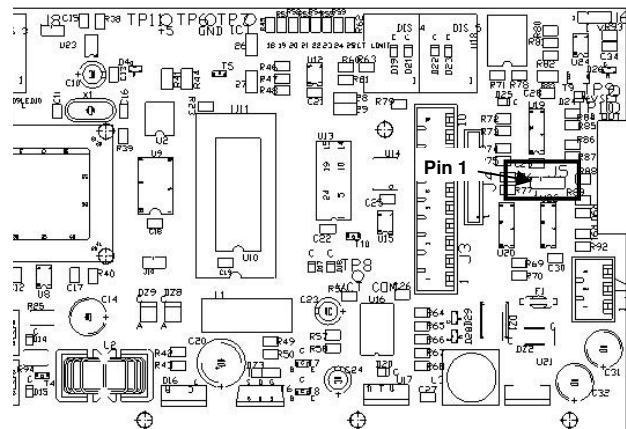

Figure 17: PC Mainboard Jumper J5 Location

8. Complete the control system I/O wiring before reconnecting the 9060 Controller to the AC source.
9. Secure the cabinet door, replace the fuses, and reconnect the AC source.
10. Refer to the "Operations" section of this service manual and use the "Remote I/O monitoring diagnostic mode" to verify that all of the I/O input connections are functioning.

NOTES

OPERATION

START-UP

After all installation procedures are completed, operation of the applicator may begin. When the ON-OFF switch is turned on, the kV display will show the applicator type the 9060 Controller is configured for and the μA (microamp) display will show the current software revision level as shown in Figure 18. These items are displayed for approximately 10 seconds.

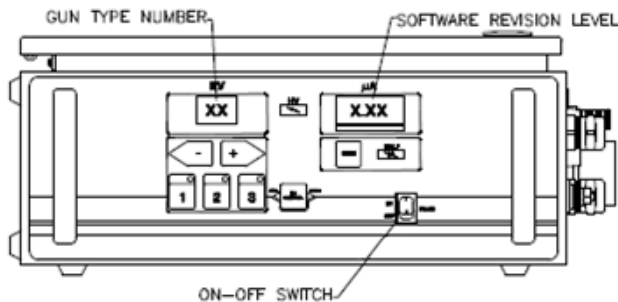

Figure 18: Controller Start-Up Display

The following table lists the applicator types shown on the display as per the current revision of this manual as a **reference**.

START-UP DISPLAY	
Applicator Type	Description
ES	Evolver SE/Esta-Quick
90	90 kV Classic
Ab	Aerobell 168

After the initial start-up delay, the unit will be configured for the applicator based on the gun type jumper settings. It will then enter LOCAL mode, unless a REMOTE mode signal is already present. At this point the unit is ready for standard operation.

! WARNING

- ▶ **VERIFY** that the gun jumper configuration is set for the applicator type that is being used for the system.
- ▶ **DO NOT** adjust the gun configuration jumpers. If they are incorrect, contact your Ransburg representative.
- ▶ **USE ONLY** the gun type configuration for the specific applicator being used. Using the wrong configuration may allow for operation outside the recommended parameters and values for the applicator and can result in **damage** or **un-safe operation**.

NOTE

- ▶ During start-up, the gun trigger or remote trigger input should **NOT** be active. An active trigger signal will cause a non-resettable **boot fault** (bF) and prevent the unit from being operated. This is designed to prevent unintended firing of the high-voltage immediately after start-up. Please refer to the "Fault Section" of this manual for more information.

BASIC OPERATIONS

The basic operations are general operations that are available in both REMOTE and LOCAL modes.

! WARNING

(For 80100-51X Units ONLY)

- ▶ **Every** time the high voltage is triggered (turned on), there is a **4 second timer** that inhibits the DI/DT overload and current overload faults while the applicator is being charged. Ensure that **NO OBJECTS** approach the bell during charging.

Triggering

High voltage is actuated by the presence of an active trigger signal. In LOCAL mode, this is normally accomplished by pulling the trigger of the handgun to start the flow of atomizing and fan control air through the applicator. When the applicator is triggered, an air flow switch is activated, and the trigger signal is issued to the 9060 unit. In REMOTE mode, the control system logic issues the trigger signal to the 9060 unit directly.

In either case, the kV setpoint is displayed on the kV display, the actual current draw on the μ A display, and the high voltage light illuminates. Under the μ A display is a bar graph meter that illuminates according to the actual current draw shown in Figure 19.

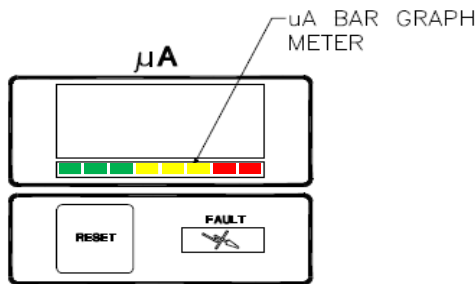

Figure 19: μ A Bar Graph Meter Display

The green and yellow regions of the bar graphs meter indicate output current is in the optimum range for maximum transfer efficiency. The red region of the bar graph indicates high output current causing decreased transfer efficiency. If high output, check maintenance of applicator and external equipment of the power supply .

Measuring “High Voltage On” Time

The 9060 High Voltage Controller records the amount of time the high voltage is triggered on up to 99,999 hours. This value is display on the kV and μ A displays of the unit. There are two registers that retain this information, one that may be reset, the other that is permanently retained in memory. The number of hours the unit’s high voltage has been on may be displayed by depressing at the same time the preset 1 and reset buttons (See Figure 20). The display will show hours of use for 3 sec-

onds. This is the resettable register.

To reset this register, press the reset button while the hours are displayed.

To view the non-resettable register, press the preset 2 and reset buttons at the same time. This display will show the hours for 3 seconds.

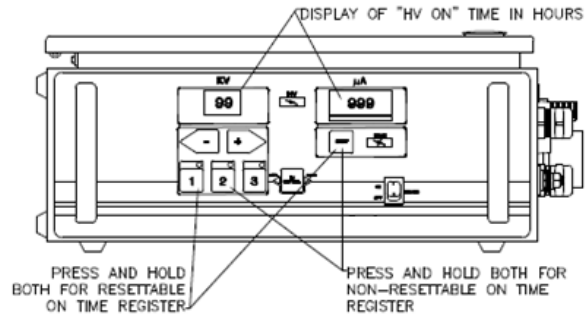

Figure 20: Display “High Voltage On” Time

Local/Remote Mode (HV Control) Button

The 9060 Controller is designed for both LOCAL and REMOTE use. Although present on the front panel, the Local/Remote mode button has no functionality. Local/Remote mode selection is controlled by the remote I/O local/remote signal line. The LOCAL and REMOTE mode (triangle) indicators on the left and right side of the mode button are shown in Figure 21. The indicator corresponding to the unit’s current operating mode should be lit while the unit is on.



Figure 21: Local/Remote Mode Button

CAUTION

► If the unit is in remote mode with no external signals connected, the unit is not functioning properly. Check remote terminal block for input signal and if none exists, send the control unit in for repair.

DI/DT CONFIGURATION

(For 80100-51X Units Only)

The 9060 Voltage Controller, model 80100-51X, for use with the ATEX approved Aerobell 168 applicator, contains a di/dt (rate of change in current with respect to time) safety overload fault and is used in addition to the standard current overload fault. This is an adjustable setting which determines the maximum current increase that can occur during a specific time period. Both the time period and sensitivity of the DI/DT configuration can be adjusted to maximize detection.

The di/dt detection feature improves the ability of the power supply to prevent discharges from the applicator to a grounded object when the object is approaching the applicator at fast speeds. Slow rates of approach are typically sensed by the current overload. The di/dt and current overloads must be set correctly to prevent discharges.

The controller monitors the output current values and compares the average rate of change over the selected time interval to the user specified settings to determine if a fault condition has occurred. If a fault occurs, the unit will turn off the high voltage and display the “dOL” fault code as shown in the “Fault Descriptions” section of this manual.



WARNING

(For 80100-51X Units ONLY)

► **Every** time the high voltage is triggered (turned on), there is a 4 second timer that ***inhibits the DI/DT overload fault*** while the applicator is being charged. Ensure that **NO OBJECTS** approach the bell during charging.

Adjusting DI/DT Parameters

The di/dt safety overload fault is configured based upon two (2) parameters; Sensitivity (SE), and Sample Time Interval (SA). These parameters can be adjusted in the Parameter Adjustment Mode. Refer to the “Parameter Adjustment Mode” portion of the “Operation” section of this manual for information on adjusting these parameters.

The sensitivity (SE) parameter determines the amount of current change that must be exceeded during the sampling time interval. The following table specifies the average amount of current change that must occur during the time interval to produce a fault based on each SE setting.

Sensitivity Values	
SE Setting	Average Rate of Change (per sampling interval)
(Most Sensitive) 2.0	4uA
3.0	6uA
4.0	8uA
5.0	10uA
6.0	12uA
7.0	14uA
8.0	16uA
9.0	18uA
10.0	20uA
11.0	22uA
(Least Sensitive) 12.0	24uA

The sample time interval (SA) parameter determines the number of samples that must be collected before a rate of change calculation is performed. This parameter can be set from 2 to 50 with a sample taken every 10 ms. This produces a sample time interval range from 20ms to 500ms. Using a larger time interval produces a di/dt configuration that is less sensitive to current spikes which are averaged out over the sample time interval and can be used to remove nuisance faults.

LOCKOUTS

There are lockouts that may be done at the PC board (see Figure 22). These lockouts may be used individually or in combination as required. If the jumpers are disconnected, the original functions are re-enabled. After changing any jumpers, the AC power must be cycled for the new setting to take affect.

NOTE

➤ Some lockouts are sealed using sealant to prevent them from being modified for safety reasons. These lockouts should **ONLY** be modified by Ransburg Authorized Representatives.

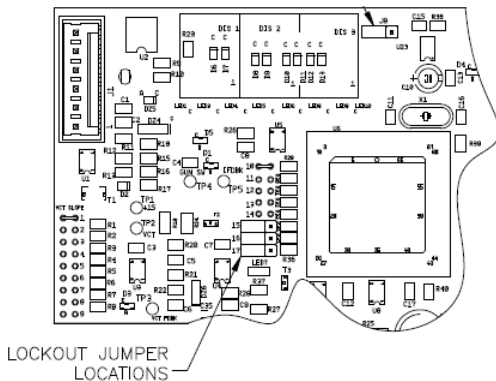

Figure 22: Lockout Jumper Location

Front Panel Lockout

This feature locks out any changes to the kV setting from the front panel of the Controller.

1. Set the kV to the desired value using the front panel buttons. This must be set prior to installing the jumper.
2. Turn AC power off and access the interior of the Controller.
3. Place the jumper across the two (2) pins at location 16 on the main PC board (See Figure 23).
4. Close the Controller and turn AC power back on. Pressing the front panel +, -, or setpoint buttons will now have no affect on the kV setting.

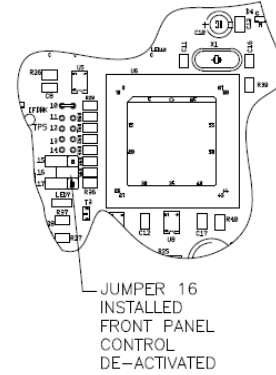

Figure 23: Jumper Location - Front Panel Lockout

Overload

The overload circuit may be activated for applications that require overload indication or notification of high current draws of the applicator. The default overload value is set in the software to the maximum microamp rating minus 10 microamps.

1. Turn AC power off and access the interior of the Controller.
2. Place the jumper across the two (2) pins at location 17 on the main PC board (See Figure 24).
3. Close the Controller and turn AC power back on. An overload fault will now occur if the microamp display exceeds the overload value.

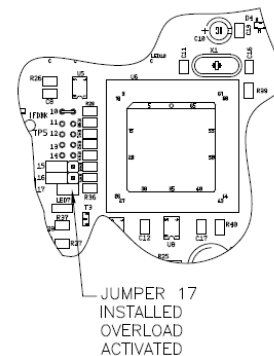

Figure 24: Jumper Location - Overload Activation

NOTE

➤ The overload circuit can **NOT** be deactivated for the AB168 (Gun Type 9) Configuration.

NOTE

► Some of the newer applicators, Type 7 (Evolver SE, Esta-Quick) and Type 9 (Aerobell 168), have adjustable overload values. Please refer to the “Parameter Adjustment Menu” part of the “Operations” section for information on adjusting the overload value.

KV TEST JUMPER

To assist in testing and troubleshooting, a jumper (J8) has been added to the main PC board. By covering (shorting) both terminals of this jumper, the high voltage of the spray applicator can be activated. Thus, for testing and troubleshooting, high voltage output can be obtained without the need to trigger air through the spray applicator. **After testing, the jumper must be repositioned so that it covers only one terminal (open) or the high voltage will stay on all the time.** See Figure 25 for the location of test jumper J8.

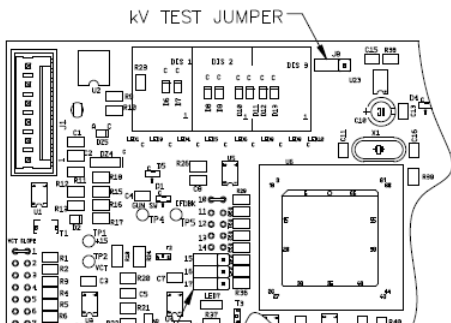

Figure 25: KV Test Jumper Location



WARNING

► If jumper J8 is left covering (shorting) both terminals, high voltage will be on whenever the AC power is turned on.

NOTE

► Use Ransburg Calibrated Equipment ONLY for testing and troubleshooting. Refer to the “Accessories” section for this manual for part numbers for testing equipment.

REMOTE I/O MONITORING DIAGNOSTIC MODE

The remote I/O monitoring diagnostic mode has three (3) sub modes. The first two (2) sub modes provide the ability to monitor the state of the analog and digital signals. The third sub mode displays the gun type value and firmware version. To enter the remote I/O monitoring and diagnostic mode, ensure that the high voltage is not activated and press all 3 preset buttons (1, 2, and 3) at the same time. This will put the unit into the Analog Signal Monitoring sub mode, with the preset 1 LED indicator lit. Each sub mode is entered by pressing one of the three preset buttons, and the corresponding LED indicator will light up. The following table lists which sub mode corresponds to which preset. To exit the diagnostic mode, from any sub mode, press the Reset Button.

Remote I/O Diagnostic Modes

Preset Button	Sub Mode
Preset 1	Analog Signal Monitoring
Preset 2	Digital Signal Monitoring
Preset 3	Gun Type / Firmware Version

NOTE

► Remote I/O Monitoring Diagnostic Mode can **ONLY** be entered when the High Voltage is **OFF** and is **ONLY** available for type 7 (Esta-Quick, Evolver SE) and Type 9 (Aerobell 168) applicators.

► While the unit is in remote I/O monitoring and diagnostic mode, the High Voltage will **NOT** be able to be activated via the trigger signal.

NOTE

► Each time a signal monitoring sub mode is entered, the signal index is reset to zero (0) moving it back to the start of the signal list for the selected mode.

Analog Signal Monitoring Mode

In the analog signal monitoring mode the kV display will show an “A#” with the “#” being the analog signal index as shown in Figure 26. The analog-to-digital converted (ADC) value of the currently selected analog signal is displayed on the μ A display. The displayed value can be in the range of 0 to 1023, with 0 corresponding to the minimum analog input value. There are a total of 8 analog signal inputs that can be monitored, they are listed in the analog index reference table under their respective index.

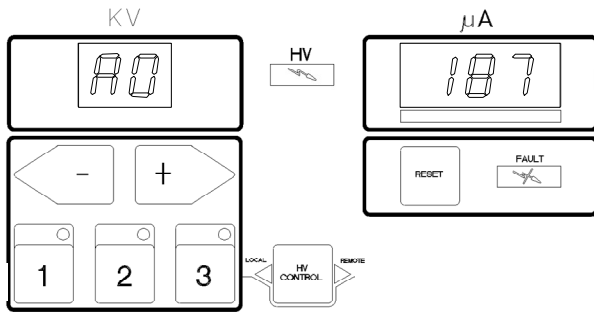

Figure 26: Analog Signal Monitoring (Index 0)

NOTE

The value displayed can range from 0 to 1023. The μ A display can only display 3 digits so the display will run:
 000 to 999
 000 to 023 (1000 to 1023)
 This range can be easily tested by slowly increasing the analog signal starting from 0

Analog Index Reference	
Index	Analog Signal
0	Buffered Gun Current Feedback
1	Current Control Feedback
2	N/A
3	Voltage Control Feedback
4	Gun Switch
5	KV Setpoint (Current or Voltage)
6	N/A
7	N/A

To navigate through the analog indexes, use the - and + buttons. Both buttons change the index by 1 for each press and will automatically wrap back around when the either end of the list is reached.

Digital Signal Monitoring Mode

In the digital signal monitoring mode the kV display will show a “d#” with the “#” being the digital signal index as shown in Figure 27 and Figure 28. The ON/OFF state of the currently selected digital signal is displayed on the μ A display as either -ON (Figure 27) or OFF (Figure 28). There are a total of 5 digital signal inputs that can be monitored, they are listed in the digital index reference table under their respective index.

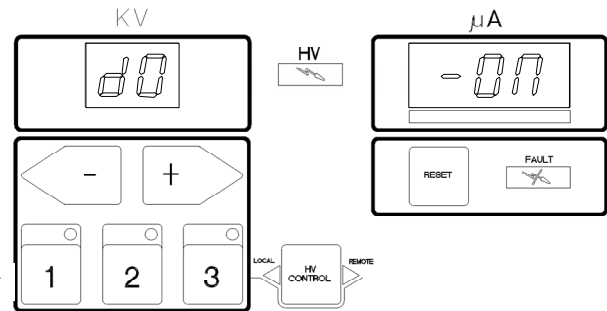

Figure 27: Digital Signal Monitoring (Index 0 - ON)

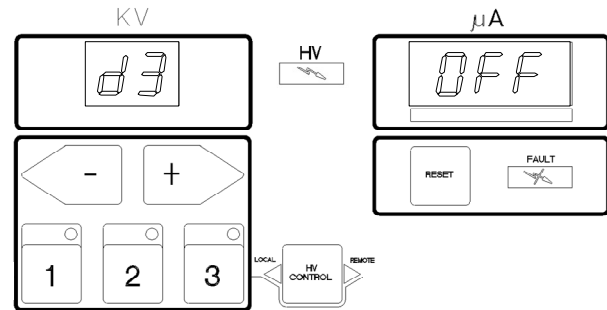

Figure 28: Digital Signal Monitoring (Index 3 - OFF)

Digital Index Reference	
Index	Analog Signal
0	Reset
1	Local/Remote Select
2	Triple Set 0
3	Triple Set 1
4	Trigger

To navigate through the digital indexes, use the - and + buttons. Both buttons change the index by 1 for each press and will automatically wrap back around when the either end of the list is reached.

Gun Type/Firmware Version Mode

This sub mode will display the gun type display value on the kV display and the firmware version number on the μ A display as shown during startup in Figure 18 during startup. As this is a sub mode of the remote I/O monitoring diagnostic mode, it will not have a limited display duration and will remain on the screen until either a different sub mode is entered or the diagnostic mode is exited.

NOTE

- The Parameter Adjustment Mode is available for Type 7 (Esta-Quick, Evolver SE) and Type 9 (Aerobell 168) automatic applicators.

PARAMETER ADJUSTMENT MODE

Certain parameters within the 9060 High Voltage Controller can be adjusted depending on the applicator being used. To enter the parameter adjustment mode, press the preset 1 and preset 3 keys at the same time. This will bring up the parameter adjustment mode as shown in Figure 29. A summary of key operations for parameter adjustment mode is shown in Figure 30.

In parameter adjustment mode, the kV display will show the 2-character code for the parameter and the μ A display will show the currently set value for the parameter. Each parameter has its own specific range limits, increment values, and indicators (if applicable). The adjustable parameter table lists the currently available parameters by character code along with their attributes.

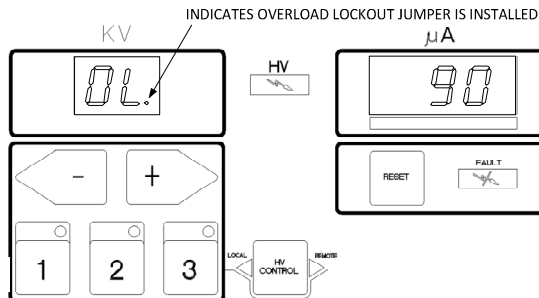

Figure 29: Parameter Adjustment Mode (Overload)

Adjustable Parameters				
Code	Parameter	Min/Max	Inc.	Indicators
OL	Current Overload	20/190	5	Decimal marker on code means overload jumper is installed
Hd	Startup Holdtime	2/15 seconds	0.5 sec.	N/A
SA	Sample Time	2-50	1	Available <u>only</u> on 51X Units
SE	Sensitivity	1.0-12.0	1	Available <u>only</u> on 51X Units

Navigating Parameters

When a parameter is currently not selected, the - and + buttons are used to navigate from one parameters to another. If the - button is pressed the previous parameter will be display. If the + button is pressed the next parameter will be displayed. The parameter adjustment menu has a wrap around indexing, so it if the end of the parameter list is reached in one direction it will automatically moved to the other end.

Selecting/Deselect Parameters

The preset 2 button is used to select/deselect the currently displayed parameter to allow it to be modified. When pressed to select the parameter, the value on the μ A display will begin flashing. This indicates the parameter has been selected and can be edited. If the preset 2 button is pressed when a parameter is already selected, it will be deselected and all modifications will be lost. The parameter's value will stop flashing indicating it has been deselected.

CAUTION

► **Be careful** when using the parameter adjustment mode, if you select something and are unsure if you've changed it, deselect it using Preset 2.

Modifying a Parameter

After a parameter has been selected using the preset 2 button and is flashing, the + and - keys can be used to increase or decrease the value of the parameter. Each parameter has its own incremental values and limits listed in the Adjustable Parameters Table. When the parameter value has been adjusted appropriately, it must be saved using the save parameter button (preset 1). If the select (preset 2) button is pressed during modification, all changes will be lost and the parameter will be deselected.

Loading Parameter Defaults

For any parameter setting, there is a default value. For example, there is a default overload value for each gun type. After a parameter has been selected, the default value can be loaded by pressing the preset 3 button. This new, default, value will only be saved if the parameter modifications are saved using the Save parameter button.

Saving Parameter Modifications

After a parameter has been selected, any changes to the value can be saved by pressing the preset 1 button. This will save the changes to memory and de-select the parameter.

NOTE

► The saved changes to parameters will immediately take effect and do not require power cycling of the unit.

Exiting the Parameter Adjustment Mode

When no parameter is selected, pressing the Reset key will exit parameter adjustment mode.

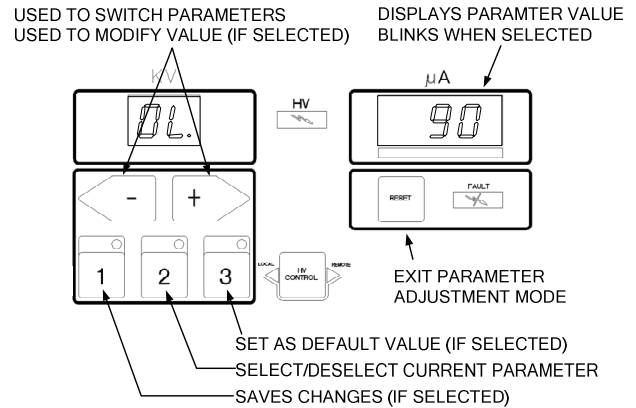

Figure 30: Summary of Adjustment Operations

LOCAL MODE ONLY OPERATIONS

Voltage Setpoints

The voltage on the 9060 High Voltage Controller is adjustable between 20 kV and full kV DC. In the LOCAL mode, there are 3 voltage setpoints (presets); 1, 2, and 3. Each of these setpoints can be individually adjusted between 20 kV and full kV DC. The three (3) factory preset voltages are listed in the following table:

Factory Presets	
Preset	Value
1	Full kV minus 20 kV
2	Full kV minus 10 kV
3	Full kV

NOTE

► The full kV DC value is determined by the gun type configuration for the particular applicator that is being used, **NOT** the full KV value of the cascade.

Setting the Setpoint

When the applicator is off in LOCAL mode, the present setpoint can be changed by pressing the 1, 2, or 3 buttons on the front panel shown in Figure 31. The setpoint that is currently selected will have the LED light in the upper right corner of the button lit.

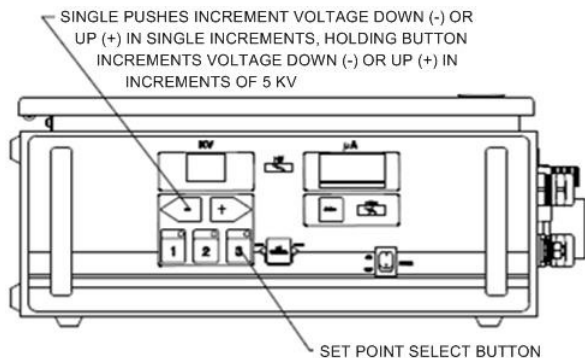

Figure 31: kV Adjust/Setpoint Buttons

Adjusting Presets

To adjust one of the preset setpoints, ensure the applicator is off in LOCAL mode and select the desired setpoint by pressing the corresponding setpoint button. The setpoint can then be adjusted between 20 kV and full kV using the + and - buttons on the front panel of the 9060 Controller shown in Figure 31. Single pushes of the + or - buttons will increment or decrement the currently selected preset in units of 1. When the + or - buttons are held in for longer than 1 second, the kV display will begin incrementing or decrementing in units of 5.

NOTE

- The three setpoints can **ONLY** be adjusted in LOCAL mode.

Resetting Faults

During operation, various faults can occur based upon the operating conditions or if any problems with the 9060 unit arise. If a fault occurs, to reset a fault, the trigger signal **MUST** be off and then press the Reset Button. This will clear the fault status and put the unit back into operation unless a fault condition is still present. Please refer to the “Fault Description” portion of the Operation Section of this Service manual for more information on a specific fault and how to correct it.

NOTE

- There is a **5 second fault reset delay timer** that **inhibits** the triggering of high voltage immediately after a fault reset.

REMOTE MODE ONLY OPERATIONS

Tripleset Selection

The tripleset signals are used to select voltage setpoints (presets) that are used during Local Mode operation. To select a setpoint, the tripleset signals must be set to the corresponding binary combination as listed in the Tripleset Selection Table.

TRIPLESET SIGNAL TIMING:

The minimum hold time for the setpoint selection signals is 10 ms.

CAUTION

- For tripleset to control the kV setpoint, no analog kV set signal should be active.

NOTE

- After the **hold time**, the simultaneous signals can be returned to off, but they must be at the same time to avoid falsely selecting a different setpoint.

Tripleset Selection

TS1	TS0	Selection
0 (off)	0 (off)	No Change
0 (off)	1 (on)	Preset 1
1 (on)	0 (off)	Preset 2
1 (on)	1 (on)	Preset 3

NOTE

- The presets can **NOT** be adjusted in remote mode. The unit must be in LOCAL mode and the preset values must be adjusted using the front panel.
- If adjustable voltage setpoints are needed, analog kV setpoint signaling is required.

Analog Setpoint Control

The analog control signals are the dominant setpoint control signals. When one of the signals is present, it will override triplaset setpoint control when the minimum analog control signal value is reached. The minimum signal required is the equivalent to 20kV. While analog control is used, the control signal can be adjusted between control signal's minimum and maximum values to adjust the output.

ANALOG SETPOINT SIGNAL TIMING:

The analog "setpoint" signal minimum hold time is 80 ms to allow for analog sampling. Output will begin to adjust after the setpoint has been updated.

ANALOG VOLTAGE SIGNALING:

Control Signal Range: 0 - 10V
 Minimum Signal (20kV): 2.0V

ANALOG CURRENT SIGNALING:

Control Signal Range: 0mA - 20mA
 Minimum Signal (20kV): 4mA

The analog input signals are *calibrated* during manufacturing. The following table lists the analog input voltages corresponding to their respective setpoints from 20kV to 90kV in 10kV increments. The actual analog value can vary slightly from unit to unit, but should be no more than $\pm 0.1V$ off the value listed below.

Analog Input Voltages	
Setpoint	Analog Voltage
20kV	2.0V
30kV	3.0V
40kV	4.0V
50kV	5.0V
60kV	6.0V
70kV	7.0V
80kV	8.0V
90kV	9.0V

NOTE

- If the setpoint values are **NOT** matching closely to the values listed in the table, the unit may need recalibrated or re-paired. Please contact your Ransburg representative.
- The 9060 Controller automatically truncates the maximum setpoint value to the maximum voltage allowed for the application being used. Control signal increases beyond the maximum voltage equivalent will have no effect.



WARNING

- **DO NOT** attempt to use both analog voltage and analog current at the same time. The analog inputs are **mutually exclusive**. Using both inputs simultaneously **will damage** the input circuit. Only one analog input, current or voltage, can be used at time to control the setpoint value.

If the analog setpoint control signal drops below the minimum setpoint value, triplaset selection will automatically take control again. This will cause the setpoint to return to the last triplaset value that was used.

Local/Remote Mode Selection

The local/remote mode selection signal is used to determine when the unit should be in LOCAL mode or REMOTE mode. This signal must remain in the active ON state for the unit to operate in REMOTE mode.

LOCAL/REMOTE MODE SIGNAL TIMING:

The local/remote mode signal hold time for a mode change is 10 ms.

NOTE

- The 9060 Controller is designed to prevent false triggering when the unit changes between LOCAL and REMOTE modes. Following any mode change, there is a 300 ms delay during which all triggers are ignored.

Reset Signal

While in REMOTE mode, if a fault occurs, the fault can be detected by the control system using the fault relay contact outputs. If the fault relay signal is active, the Reset Signal can be used to clear the fault status. To clear a fault using the reset signal, turn off the trigger signal, then turn on the reset signal for approximately 10 ms to reset the fault.. Then turn off the reset signal.

RESET SIGNAL TIMING:

The reset signal has a minimum hold time of 10 ms.

NOTE

- There is a **5 second fault reset delay timer** that **inhibits** the triggering of high voltage immediately after a fault reset.
- The Reset button on the front panel can also be used in REMOTE mode to clear a fault condition as long as the front panel lockout jumper is not installed.

Trigger Signal

The trigger signal is used to activate the High Voltage output from the cascade.

TRIGGER SIGNAL TIMING:

The trigger signal minimum hold time is 10 ms.



CAUTION

- The signal Hold Times are the minimum required for the processor to detect the signal. During actual operations, signal time durations are expected to be much greater than the minimums.

FAULT DESCRIPTIONS

For in depth troubleshooting information on the 9060, please refer to the "Fault Troubleshooting" portion of the Maintenance Section of this service manual. If a fault occurs, the Fault Indicator on the front of the Controller will light and a fault code will be displayed on the

microamp display. Faults can be reset by pressing the Reset button on the front of the Controller or by using the remote I/O reset signal.

NOTE

- **Any** fault code not listed that appear on the screen are a likely indication of a PC board failure due to possible arc damage.

Boot Fault (bF)

This fault will occur during the start-up sequence if an active trigger signal is present. It is designed to prevent immediate triggering after start-up as the unit should be allowed to enter the "ready" state prior to being triggered. This fault also prevents the high voltage from being fired if the microprocessor resets. For additional information, refer to the Fault Troubleshooting Section.

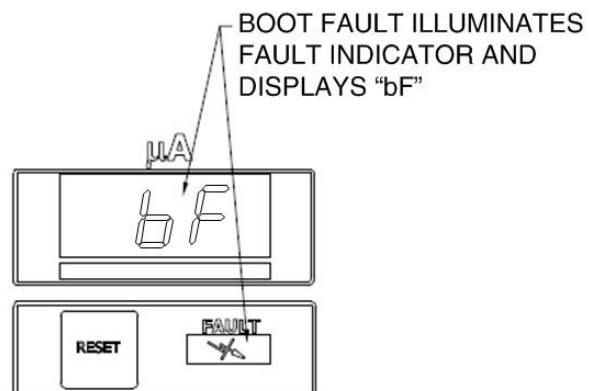

Figure 32: Boot Fault Display

Cable Fault (CF)

This fault will occur if high voltage is active and the microprocessor detects that no current is being supplied to the high voltage section. This indicates a connection problem from the control unit to the high voltage section or external cascade. In external cascade applications, a failed low voltage cable can cause this fault. For additional information, refer to the Fault Troubleshooting Section.

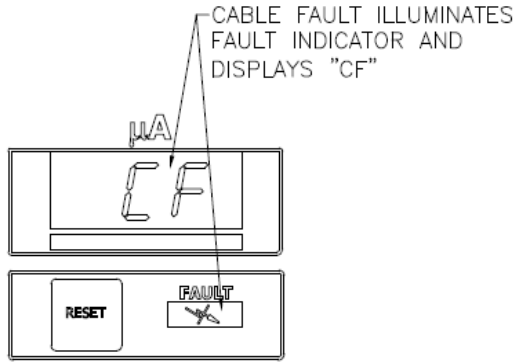

Figure 33: Cable Fault Display

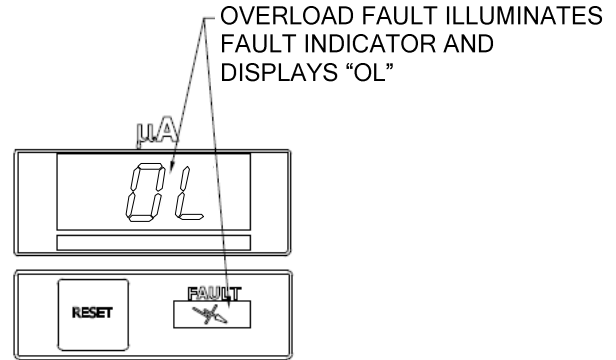

Figure 35: Overload Fault Display

Ground Fault (GF)

If this fault occurs, the fault indicator on the control unit will illuminate, a GF indication will show in the uA display. This fault will occur if the microprocessor detects a loss of ground at the high voltage section or external cascade. If this fault occurs, reset the fault. This fault can be caused by a broken ground path between the high voltage section and the pc board. In external cascade applications, a failed low voltage cable can cause this problem. Check the wiring to the high voltage section. For more information, refer to Fault Troubleshooting Section.

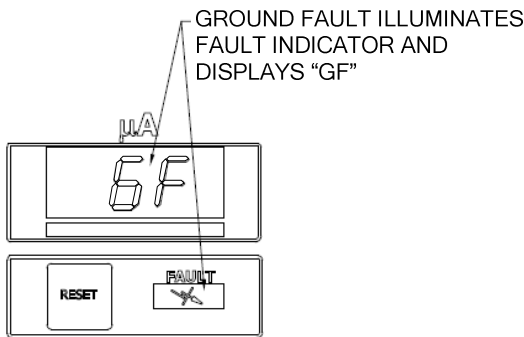

Figure 34: Ground Fault Display

Current Limit Fault (CL)

This fault occurs if the output current exceeds the maximum current by 20µA. This fault can be caused by excessive overspray on the applicator or a paint formulation that is too conductive. It may also be caused by a bad pc board. Clean the applicator, check the paint formulation, and re-test. If still a problem, replace the pc board. See Fault Troubleshooting Section for more information.

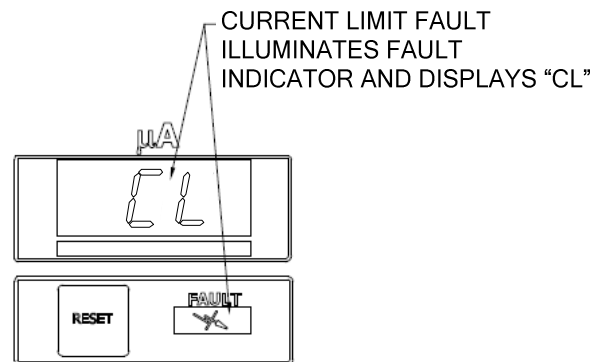

Figure 36: Current Limit Fault Display

Overload Fault (OL)

This fault will occur if the overload feature is active (see 'Overload Activation' previously in the "Operation" section) and the output current exceeds the overload current value. This can be caused by excessive overspray on the applicator or paint formulation that is too conductive. Clean the applicator, check the paint formulation, or move overload jumper (JP17) to the open position.

Voltage Cable Fault (UC)

This fault will occur if the microprocessor detects a loss of the voltage feedback signal. This can be caused by a failed high voltage cable, a failed high voltage section, or a failed pc board.

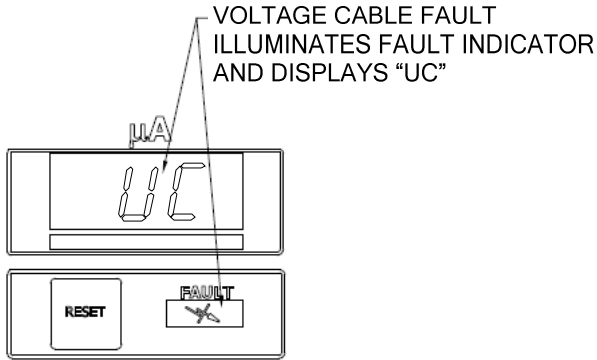

Figure 37: Voltage Cable Fault Display

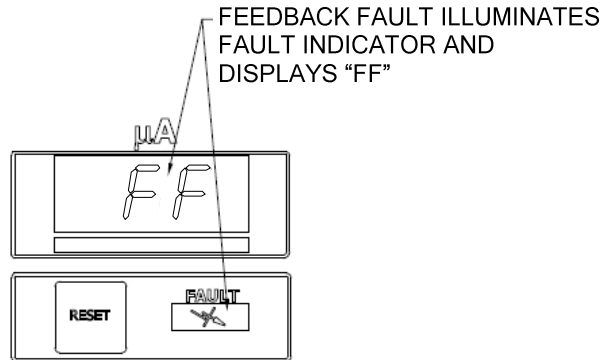

Figure 39: Feedback Fault Display

Over Voltage Fault (OU)

This fault will occur if the microprocessor detects the unit is trying to output voltage above the required for the specific applicator type. If this occurs, reset the Controller. If this fault continues to occur, replace the main PC board.

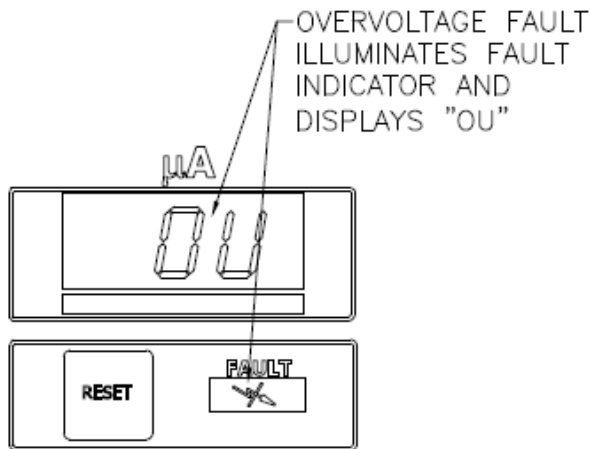

Figure 38: Over Voltage Fault Display

DI/DT Overload Fault (dOL)

This fault is ONLY applicable to 80100-51X units. This fault will occur if the microprocessor detects that the rate of current change has exceeded the limits specified in the user DI/DT settings. If this occurs, reset the fault. Check to ensure that no object is moving toward the applicator within the minimum safe distance, adjust the DI/DT settings if necessary, and re-test operation. If this fault continues to occur, contact your Ransburg Representative.

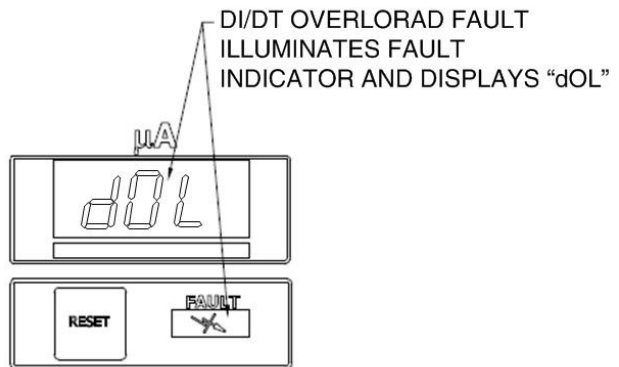

Figure 40: DI/DT Overload Fault Display

Feedback Fault (FF)

This fault will occur if the microprocessor detects a loss of the current feedback signal. If this occurs, reset the fault. If this fault occurs repeatedly, replace the cascade or send the high voltage controller in for repair.

NOTES

MAINTENANCE

TROUBLESHOOTING GUIDE

General Problem	Possible Cause	Solution
Blank Display	<ol style="list-style-type: none"> 1. No power 2. Blown fuse 3. Faulty +24 volt power supply 	<ol style="list-style-type: none"> 1. Check the power connections and verify they are fully connected and power is available. Power cycle the unit off and back on. 2. Check Fuses and replace if blown using the replacement fuses inside the lid of the unit. 3. Check green led on 24 volt power supply, when power is applied LED must be on. If the LED is not on, replace 24 volt power supply .

FAULT TROUBLESHOOTING GUIDE

WARNING

► Before troubleshooting gun and control unit problems, flush the gun with solvent and purge with air. Some of the tests will require high voltage to be applied to the gun, so the gun must be empty of paint and solvent.

Fault	Description	Solution
Cable Fault (CF)	The Cable Fault indicates the control unit does not detect a high voltage section on the end of the cable. The fault typically occurs at a high voltage trigger.	<ol style="list-style-type: none"> 1. Check for loose wiring between the pc board connector and the high voltage section by pulling on each wire. Repair if necessary. Insure both connectors are secure and re-test for CF fault. 2. Replace high voltage section. 3. Send unit in for repair.

Fault	Description	Solution
Ground Fault (GF)	The Ground Fault is typically caused by a ground connection problem, and can create a safety hazard. It can occur without high voltage and will not reset.	<ol style="list-style-type: none"> 1. Check for loose wiring between the pc board connector and the high voltage section by pulling on each wire. Repair if necessary. Insure both connectors are secure and re-test for GF fault. For external cascades, measure resistance between ground and external cascade ground stud—if greater than 5 ohms replace low voltage cable. 2. Replace high voltage section. 3. Send unit in for repair.
Over-Voltage Fault (OU)	The Over Voltage Fault indicates the output voltage exceeds the design specifications. It typically occurs during a high voltage trigger.	<ol style="list-style-type: none"> 1. Check connections using two finger pull test to ensure they are connected. 2. Replace the main pc board. 3. Send high voltage control unit in for repair.
Over-Load Fault (OL)	The Over Load Fault indicates the current output has exceeded the overload threshold. This fault is only active if jumper 17 is shorted. The overload threshold is <u>normally</u> set at 10 μ A below the maximum output of the applicator.	<ol style="list-style-type: none"> 1. This may indicate the paint conductivity is too high (resistance too low) or the outside of the applicator is contaminated with paint. Test paint for proper conductivity or clean applicator with non-polar solvent. Ensure dump lines are clean.
Current Limit Fault (CL)	The Current Limit Fault indicates the current output of the gun has exceeded the maximum allowable output current. It typically occurs with the high voltage on.	<ol style="list-style-type: none"> 1. This may indicate the paint conductivity is too high (resistance too low) or the outside of the applicator is contaminated with paint. Test paint for proper conductivity or clean applicator with non-polar solvent. Ensure dump lines are clean. 2. Replace applicator and re-test. If problem still exists, replace main pc board. 3. Send applicator in for repair.
Feedback Fault (FF)	The Feedback Fault indicates there is no current feedback or it is incorrect. It typically occurs with the high voltage on.	<ol style="list-style-type: none"> 1. Send high voltage controller in for repair.

Fault	Description	Solution
Voltage Cable Fault (UC)	The Voltage Feedback Fault indicates the cascade drive signal is not present. It typically occurs when high voltage is triggered.	<ol style="list-style-type: none"> 1. Turn off the voltage controller and remove the high voltage cable from the voltage controller. 2. Turn on the power and place HV test jumper J8 in shorted position. If the UC fault occurs, send the high voltage controller in for repair. If no fault occurs, continue. 3. The high voltage cable may have failed. Replace the high voltage cable and re-test. 4. Send applicator unit in for repair.
Boot Fault (bF)	The Boot Fault indicates that an active trigger signal was detected during the start-up sequence.	<ol style="list-style-type: none"> 1. Turn off the voltage controller. 2. Ensure that the gun trigger is not pressed or for remote units that the remote trigger input signal is not active. 3. Turn on the voltage controller to verify that a trigger signal is not present and that the unit enters the 'ready' state. 4. Send the voltage controller in for repair or contact technical support.
DI/DT Overload Fault (dOL) <u>(For 80100-51X units only)</u>	The DI/DT Overload Fault indicates that the change in current has exceeded the user specified current limit (sensitivity, SE), during the user selected time interval (Sample Time, SA).	<ol style="list-style-type: none"> 1. Ensure that the target and no other object is approaching the applicator within the minimum safe distance during application. Reset the fault and re-test operation. 2. Using the parameter adjustment mode, adjust the sensitivity and sample time interval configuration values for DI/DT. Re-test operation for different values. 3. Contact technical support for further assistance.

NOTES

PARTS IDENTIFICATION

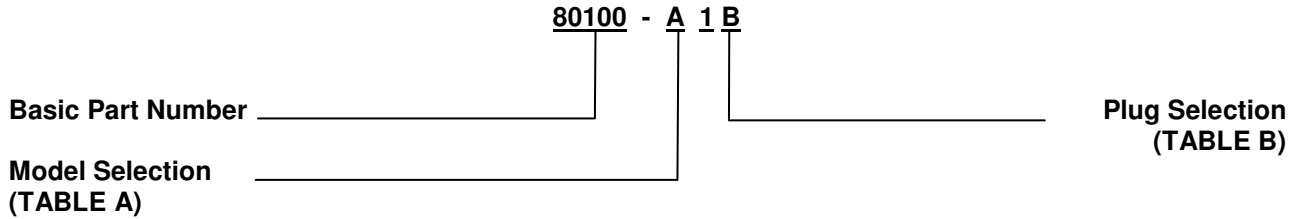

9060 HIGH VOLTAGE CONTROLLER MODEL IDENTIFICATION *

When ordering, use 80100-A1B as indicated by Table A and B. Three digits must follow the basic part number, for example:



* Model number and serial number of the voltage controller is located on the left outside face of the main enclosure.

Table A - Model Selection	
Dash No.	Description
2	Internal Cascade - Non Approved
3	External Cascade - Atex Approved with Esta-Quick
4	External Cascade - Non Approved with Evolver SE
5	External Cascade - Atex Approved with Aerobell 168

Table B - Plug Selection	
Dash No.	Description
1	Domestic 
2	Europe 
3	China 

9060 High Voltage Controller - Parts List	
Part #	Description
72771-06	Fuse (250V, 1A, 5mm x 20mm)
80116-41	9060 High Voltage Controller PC Mainboard (for 80100-21X, 31X, 41X)
80116-68	9060 High Voltage Controller PC Mainboard (for 80100-51X)
A13123-00	9060 High Voltage Controller Local/Remote Board
79350-01	9060 High Voltage Cascade
79428-00	Power Supply, 24V (24VDC Power Supply 1PS)
76434-01	Switch, Rocker (On-Off Switch)

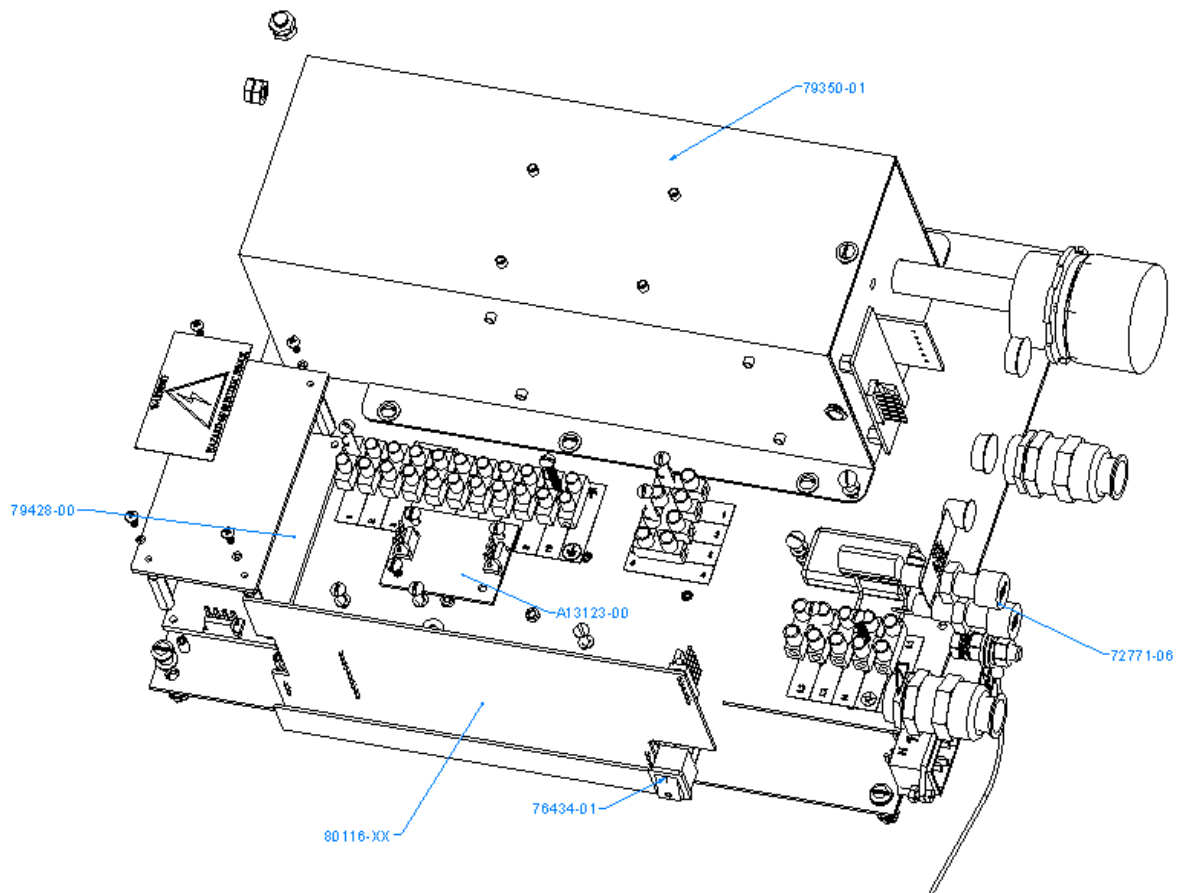

Figure 40: Part Identifications

ACCESSORIES

9060 High Voltage Controller - Accessories List	
Part #	Description
76652-01	HV Probe
76652-02	Meter w/Test Leads
76652-03	Paint Test Probe w/Meter
76652-04	Deluxe Kit (Include HV Probe, Meter w/Test Leads, and Paint Test Probe)

WARRANTY POLICIES

LIMITED WARRANTY

Ransburg will replace or repair without charge any part and/or equipment that falls within the specified time (see below) because of faulty workmanship or material, provided that the equipment has been used and maintained in accordance with Ransburg's written safety and operating instructions, and has been used under normal operating conditions. Normal wear items are excluded.

THE USE OF OTHER THAN RANSBURG APPROVED PARTS, VOID ALL WARRANTIES.

SPARE PARTS: One hundred and eighty (180) days from date of purchase, except for rebuilt parts (any part number ending in "R") for which the warranty period is ninety (90) days.

EQUIPMENT: When purchased as a complete unit, (i.e., guns, power supplies, control units, etc.), is one (1) year from date of purchase.

WRAPPING THE APPLICATOR, ASSOCIATED VALVES AND TUBING, AND SUPPORTING HARDWARE IN PLASTIC, SHRINK-WRAP, OR ANY OTHER NON-APPROVED COVERING, WILL VOID THIS WARRANTY.

RANSBURG'S ONLY OBLIGATION UNDER THIS WARRANTY IS TO REPLACE PARTS THAT HAVE FAILED BECAUSE OF FAULTY WORKMANSHIP OR MATERIALS. THERE ARE NO IMPLIED WARRANTIES NOR WARRANTIES OF EITHER MERCHANTABILITY OR FITNESS FOR A PARTICULAR PURPOSE. RANSBURG ASSUMES NO LIABILITY FOR INJURY, DAMAGE TO PROPERTY OR FOR CONSEQUENTIAL DAMAGES FOR LOSS OF GOODWILL OR PRODUCTION OR INCOME, WHICH RESULT FROM USE OR MISUSE OF THE EQUIPMENT BY PURCHASER OR OTHERS.

EXCLUSIONS:

If, in Ransburg's opinion the warranty item in question, or other items damaged by this part was improperly installed, operated or maintained, Ransburg will assume no responsibility for repair or replacement of the item or items. The purchaser, therefore will assume all responsibility for any cost of repair or replacement and service related costs if applicable.

Manufacturing

1910 North Wayne Street
Angola, Indiana 46703-9100
Telephone: 260-665-8800
Fax: 260-665-8516

Technical Service—Assistance

320 Philips Ave.
Toledo, Ohio 43612-1493
Telephone (toll free): 800-233-3366
Fax: 419-470-2233

Technical Support Representative will direct you to the appropriate telephone number for ordering Spare Parts.