

Gas Pressure Fryer

MODELS LGF, LGF-F, & LGF-FC

Service Manual

Serial Numbers 137733 and higher



BKI LIMITED WARRANTY

2812 Grandview Dr. • Simpsonville, SC 29680 • USA
(864) 963-3471 • Toll Free: (800) 927-6887 • Fax: (864) 963-5316

WHAT IS COVERED

This warranty covers defects in material and workmanship under normal use, and applies only to the original purchaser providing that:

- ☒ The equipment has not been accidentally or intentionally damaged, altered or misused;
- ☒ The equipment is properly installed, adjusted, operated and maintained in accordance with national and local codes, and in accordance with the installation and operating instructions provided with this product.
- ☒ The serial number rating plate affixed to the equipment has not been defaced or removed.

WHO IS COVERED

This warranty is extended to the original purchaser and applies only to equipment purchased for use in the U.S.A.

COVERAGE PERIOD

- ☒ Warranty claims must be received in writing by BKI within one (1) year from date of installation or within one (1) year and three (3) months from data of shipment from the factory, whichever comes first.
- ☒ COB Models: One (1) Year limited parts and labor.
- ☒ COM Models: Two (2) Year limited parts and labor. COM convection ovens also have a two (2) year door warranty.
- ☒ CO1 Models: Two (2) Year limited parts and labor. Five (5) Year limited door warranty.
- ☒ BevLes Products: Two (2) Year limited parts and labor.
- ☒ Warranty period begins the date of dealer invoice to customer or ninety (90) days after shipment date from BKI, whichever comes first.

WARRANTY COVERAGE

This warranty covers on-site labor, parts and reasonable travel time and travel expenses of the authorized service representative up to (100) miles round trip and (2) hours travel time and performed during regular, weekday business hours.

EXCEPTIONS

Any exceptions must be pre-approved in advance and in writing by BKI. The extended door warranty on convection ovens years 3 through 5 is a parts only warranty and does not include labor, travel, mileage or any other charges.

EXCLUSIONS

- ☒ Negligence or acts of God,
- ☒ Thermostat calibrations after (30) days from equipment installation date,
- ☒ Air and gas adjustments,
- ☒ Light bulbs,
- ☒ Glass doors and door adjustments,
- ☒ Fuses,
- ☒ Adjustments to burner flames and cleaning of pilot burners,
- ☒ Tightening of screws or fasteners,
- ☒ Failures caused by erratic voltages or gas suppliers,
- ☒ Unauthorized repair by anyone other than a BKI Factory Authorized Service Center,
- ☒ Damage in shipment,
- ☒ Alteration, misuse or improper installation,
- ☒ Thermostats and safety valves with broken capillary tubes,
- ☒ Freight - other than normal UPS charges,
- ☒ Ordinary wear and tear,
- ☒ Failure to follow installation and/or operating instructions,
- ☒ Events beyond control of the company.

INSTALLATION

Leveling, as well as proper installation and check out of all new equipment - per appropriate installation and use materials – is the responsibility of the dealer or installer, not the manufacturer.

REPLACEMENT PARTS

BKI genuine Factory OEM parts receive a (90) day materials warranty effective from the date of installation by a BKI Factory Authorized Service Center.

NOTICE	The purchaser must post, in a prominent location, instructions to be followed in the event the user smells gas. This information shall be obtained by consulting the local gas supplier.
---------------	--

⚠ WARNING	FOR YOUR SAFETY Do not store or use gasoline or other flammable vapors or liquids in the vicinity of this or any other appliance.
------------------	--

⚠ WARNING	Improper installation, adjustment, alteration, service or maintenance can cause property damage, injury or death. Read the installation, operation and maintenance instructions thoroughly before installing or servicing this equipment.
------------------	--

Table of Contents

Table of Contents	1
Introduction	2
Safety.....	2
Safety Signs and Messages.....	2
Specific Precautions	3
Equipotential ground plane	3
Full Disconnection.....	3
Safe Work Practices	4
Safety Labels.....	9
Installation	11
Operation	12
Controls and Indicators.....	12
Care of the Shortening	15
LGF and LGF-F Operation	15
Start-Up (LGF and LGF-F)	15
Cooking (LGF and LGF-F)	16
LGF-FC Operation	18
System Programming.....	18
Product Programming	20
Start-Up (LGF-FC).....	23
Cooking (LGF-FC).....	23
Recipes	25
Operation After Gas or Power Outage	27
Normal Shutoff.....	27
Maintenance	28
Replacement Parts	29
Assemblies	29
Accessories	50
Components	51
Wiring Diagrams	52

Introduction

The LGF Pressure Fryer is compact, attractive and functional in design. It is constructed of a stainless steel fryer pot for cleaning ease. Exclusive BKI patented features and safety devices offer flexibility, efficiency and reliability plus **PERFECTION IN PRESSURE FRYING!**

The BKI name and trademark on this unit assures you of the finest in design and engineering -- that it has been built with care and dedication -- using the best materials available. Attention to the operating instructions regarding proper installation, operation, and maintenance will result in long lasting dependability to insure the highest profitable return on your investment.

NOTICE

PLEASE READ THIS ENTIRE MANUAL BEFORE OPERATING THE UNIT. If you have any questions, please contact your BKI Distributor. If they are unable to answer your questions, contact the BKI Technical Service Department, toll free: 1-800-927-6887. Outside the U.S., call 1-864-963-3471.

Safety

Always follow recommended safety precautions listed in this manual. Below is the safety alert symbol. When you see this symbol on your equipment, be alert to the potential for personal injury or property damage.



Safety Signs and Messages

The following Safety signs and messages are placed in this manual to provide instructions and identify specific areas where potential hazards exist and special precautions should be taken. Know and understand the meaning of these instructions, signs, and messages. Damage to the equipment, death or serious injury to you or other persons may result if these messages are not followed.

DANGER

This message indicates an imminently hazardous situation which, if not avoided, will result in death or serious injury.

WARNING

This message indicates a potentially hazardous situation, which, if not avoided, could result in death or serious injury.

CAUTION

This message indicates a potentially hazardous situation, which, if not avoided, may result in minor or moderate injury. It may also be used to alert against unsafe practices.

NOTICE

This message is used when special information, instructions or identification are required relating to procedures, equipment, tools, capacities and other special data.

Specific Precautions

⚠ DANGER

Lids for LGF Pressure Fryers manufactured prior to May 27, 1980 (or units with serial numbers lower than 3613) could be manually opened while under pressure resulting in serious injury or death. If you have one of these units, please contact the BKI Technical Services Department toll-free at 1-800-927-6887 for urgent update information.

⚠ WARNING

Risk of fire exists if the oil level drops below 5mm of the maximum oil level.

⚠ WARNING

Use of oil/shortening older than the manufacturers recommendations for life of the oil is prone to surge boiling and flash fires. Follow the oil manufacturers guidelines for the life cycle of oil/shortening.

⚠ WARNING

Do not open the drain valve or the fill valve while the fryer is under pressure. Serious burns may result.

⚠ CAUTION

Follow instructions regarding effects of surge boiling of over-wet foods and proper load size.

⚠ CAUTION

This unit incorporates components that contain Mercury. The use of Mercury relays is an industry standard.

⚠ CAUTION

Equipotential ground plane

When a high current flows through a conductor, differences in potential appear between the conductor and nearby metallic surfaces near the appliance. As a result, sparks may be produced between the appliance and surrounding metal surfaces. These sparks could cause serious injury, damage, or fire.

BKI provides an Equipotential ground terminal for the connection of a bonding conductor after the installation of the appliance per IEC60417-1. This terminal is located on the inside of the Power Entry Supply box near the Earth connection and is marked with this symbol.



NOTICE

Full Disconnection

In accordance with Local and/or National wiring codes, the installer must provide a means of full disconnection under over voltage Category III conditions. An IEC approved cord and plug combination will meet this requirement.

Units not provided with a cord and plug do not meet this requirement. In accordance with Local and/or National wiring codes, the installer must provide the means of full disconnection.

NOTICE

The fryer is designed to hold a maximum of 35lbs (15.9KG) of oil/shortening.

Safe Work Practices



Do Not Store Or Use Anything Flammable Near The Fryer

Your pressure fryer is powered by either natural gas or LP gas. Do not store or use gasoline or any flammable liquids or vapors near this or any other appliance. Flammable materials will burn easily. Letting any flammable liquid or vapor get too close to the fryer could cause an explosion or fire. Serious injury could result. Examples of flammables that you should not store near the fryer are gasoline, paint, thinners or removers, gas tanks, and cleaning materials.



Use Gas Safely-- Avoid Danger

Gas can be a dangerous fuel if not handled safely.

Make sure to ventilate the fryer properly. If the fryer is not properly ventilated, carbon monoxide can be released around the fryer. Asphyxiation or suffocation can occur if gas is not ventilated properly.

Before using this appliance for the first time, contact your local gas supplier for instructions about what to do if you smell gas. Post those instructions somewhere near the fryer, so that everyone who uses or works near the fryer knows what to do if they smell gas.

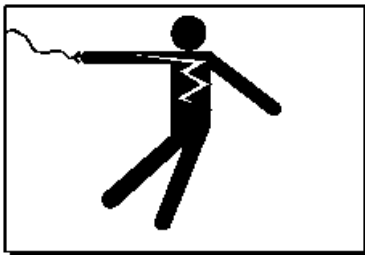

Beware of High Voltage

This equipment uses high voltage. Serious injury can occur if you or any untrained or unauthorized person installs, services, or repairs this equipment. Always Use an Authorized Service agent to Service Your Equipment.



Use the Fryer On Noncombustible Floors Only

Make sure your floor is noncombustible. Do not operate your fryer on floors that are wood, carpeted or have rubber mats. Placing your fryer on a combustible floor could cause a fire. Serious injury could result. Examples of noncombustible floors where you can safely place your fryer are concrete, tile, and ceramic.

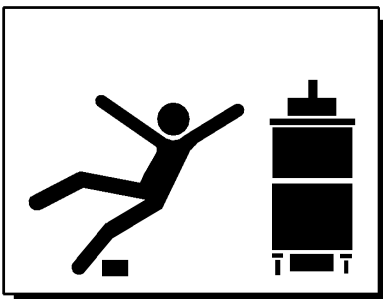

Keep The Area Around Your Fryer Uncluttered

Make sure to keep the area around your fryer clear of any obstacles. Serious injury can occur if you trip or fall near the fryer. You could be burned by hot shortening that splashes out of the fryer or by falling against the hot metal of the fryer.



Keep The Floor Around Your Fryer Clean Of Shortening

Make sure to keep the floor around your fryer clean of shortening and other liquids. Serious injury can occur if you slip near your fryer. You could be burned by hot shortening that splashes out of the fryer or by falling against the hot metal of the fryer.

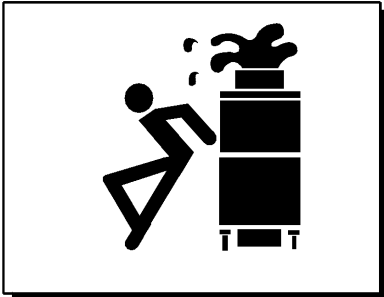

Keep The Lid Closed When The Fryer Is Not In Use

Hot shortening can splash if someone moves the fryer or bumps into it. Serious injury can occur if hot shortening splashes out of the fryer.

Do not lean, sit or stand on the fryer or perform any maintenance or cleaning duties while the fryer or the shortening is hot. You could be burned.

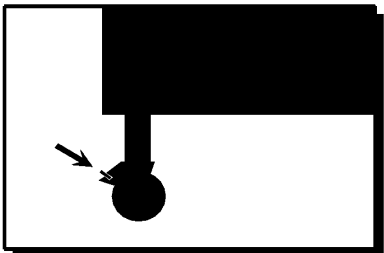

Keep The Casters Locked

To avoid spilling shortening, keep the casters locked. If any shortening spills near your fryer, clean it up immediately.

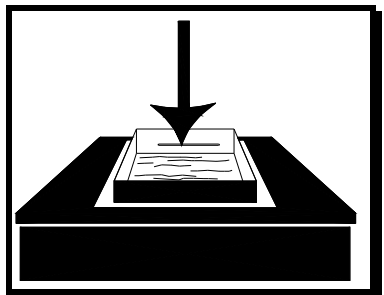

Do Not Overfill The Fryer With Shortening

Hot shortening and steam may escape and burn you if you put too much shortening in the fryer. Fill the fryer to approximately one inch below the fill marks that are inside the fryer pot. Heat the shortening. If needed, carefully add more shortening to bring the level to the fill marks.

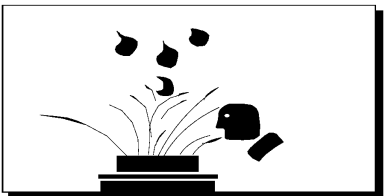

Do Not Let Any Water Get Into The Fryer

Always remove excess moisture from food before placing it into the fryer basket. Water will cause the hot shortening to spatter. You could be burned.



Do Not Overload The Basket With Food

Hot shortening and steam may escape and burn you if you place too much food in the basket.

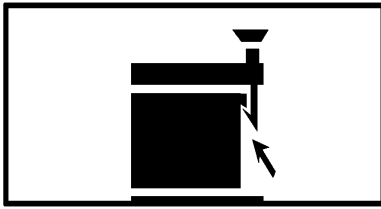

Always Make Sure The Lid Hook Is Latched When Closing The Fryer

To make sure the lid hook is latched properly, press down the lid until the hook snaps shut. Hot shortening and steam can escape if the lid hook is not latched properly. You could be burned.

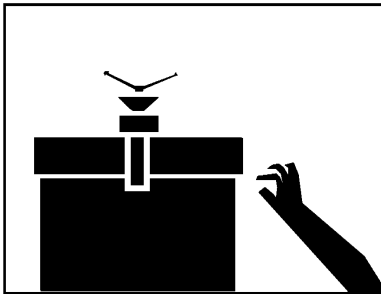

Always Tighten The Spin Handle When Closing The Fryer

Hot shortening and steam can escape if you do not tighten the spin handle properly. You could be burned. Line up the orange knobs on the fryer lid handle and the front hook when tightening.

Do Not Over-Tighten The Spin Handle

You could damage the fryer.

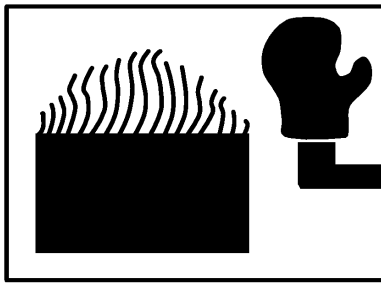

Wear Safe Clothing Appropriate To Your Job

Always wear your insulated mitts when handling the fryer basket or touch any hot metal surfaces. You received a pair of insulated mitts with your fryer. If you lose or damage your mitts, you can buy new ones at your local restaurant equipment supply store or from your local **BKI** Distributor.

Always wear non-skid shoes when working around the fryer or any other equipment that uses shortening. Never wear loose clothing such as neckties or scarves while operating your fryer. Keep loose hair tied back or in a hair net while operating your fryer.

Always wear appropriate personal protection equipment during the filtering process to guard against possible injury from hot oil.

Always wear appropriate personal protection equipment during the boil-out process to guard against possible injury from hot cleaning solution.

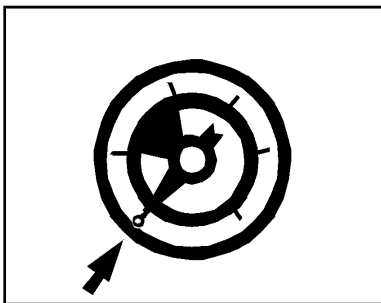

Never Loosen The Spin Handle Until The Pressure Gauge Is At Zero

Steam may escape suddenly if you loosen the spin handle before the gauge is at zero. If steam escapes suddenly, you could be burned.

After the pressure gauge is at zero, wait 5 seconds. Then loosen the spin handle slowly to open the lid of the fryer. By doing this, the steam will escape slowly and you will not be burned.

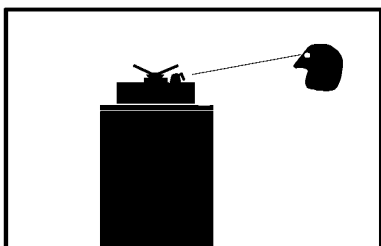

Seal The Safety Valve Properly

To seal the safety valve, lift the arm on the side of the valve. Then release it. The valve should snap closed. Hot steam can escape from the valve and you could be burned if you do not seal the valve properly.

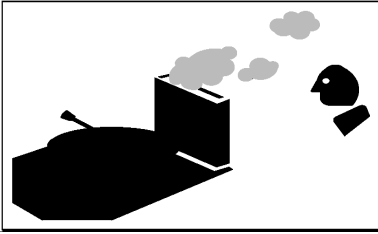

Keep Away From The Vent

Hot steam escapes from the vent continuously when you are using your fryer. You could be burned if you get too close to the vent.

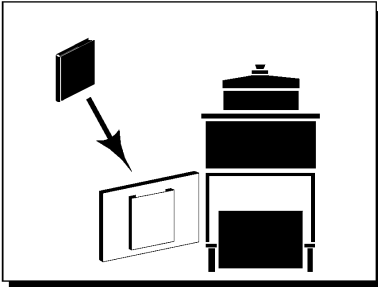

Keep this manual with the Equipment

This manual is an important part of your equipment. Always keep it near for easy access.

If you need to replace this manual, contact:

BKI

Technical Services Department
2812 Grandview Drive
Simpsonville, S.C. 29680
Or call toll free: 1-800-927-6887
Outside the U.S., call 864-963-3471



Protect Children

Keep children away from this equipment. Children may not understand that this equipment is dangerous for them and others.

NEVER allow children to play near or operate your equipment.

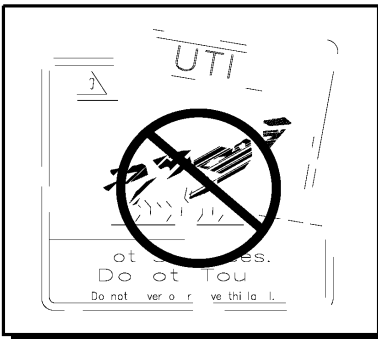

Keep Safety Labels Clean and in Good Condition

Do not remove or cover any safety labels on your equipment. Keep all safety labels clean and in good condition. Replace any damaged or missing safety labels. Refer to the Safety Labels section for illustration and location of safety labels on this unit.

If you need a new safety label, obtain the number of the specific label illustrated on page 9, then contact:

BKI

Technical Services Department
2812 Grandview Drive
Simpsonville, S.C. 29680
Or call toll free: 1-800-927-6887
Outside the U.S., call 864-963-3471

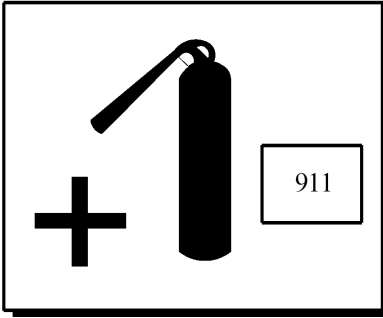

Be Prepared for Emergencies

Be prepared for fires, injuries, or other emergencies.

Keep a first aid kit and a fire extinguisher near the equipment. You must use a 40-pound Type BC fire extinguisher and keep it within 25 feet of your equipment.

Keep emergency numbers for doctors, ambulance services, hospitals, and the fire department near your telephone.

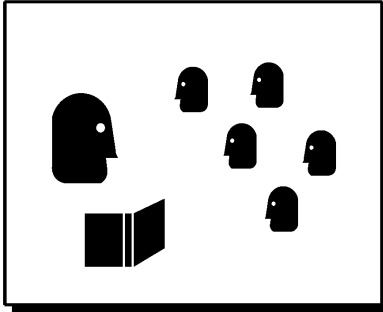

Know your responsibilities as an Employer

- Make certain your employees know how to operate the equipment.
- Make certain your employees are aware of the safety precautions on the equipment and in this manual.
- Make certain that you have thoroughly trained your employees about operating the equipment safely.
- Make certain the equipment is in proper working condition. If you make unauthorized modifications to the equipment, you will reduce the function and safety of the equipment.



Do Not Smoke Near The Fryer.

Safety Labels

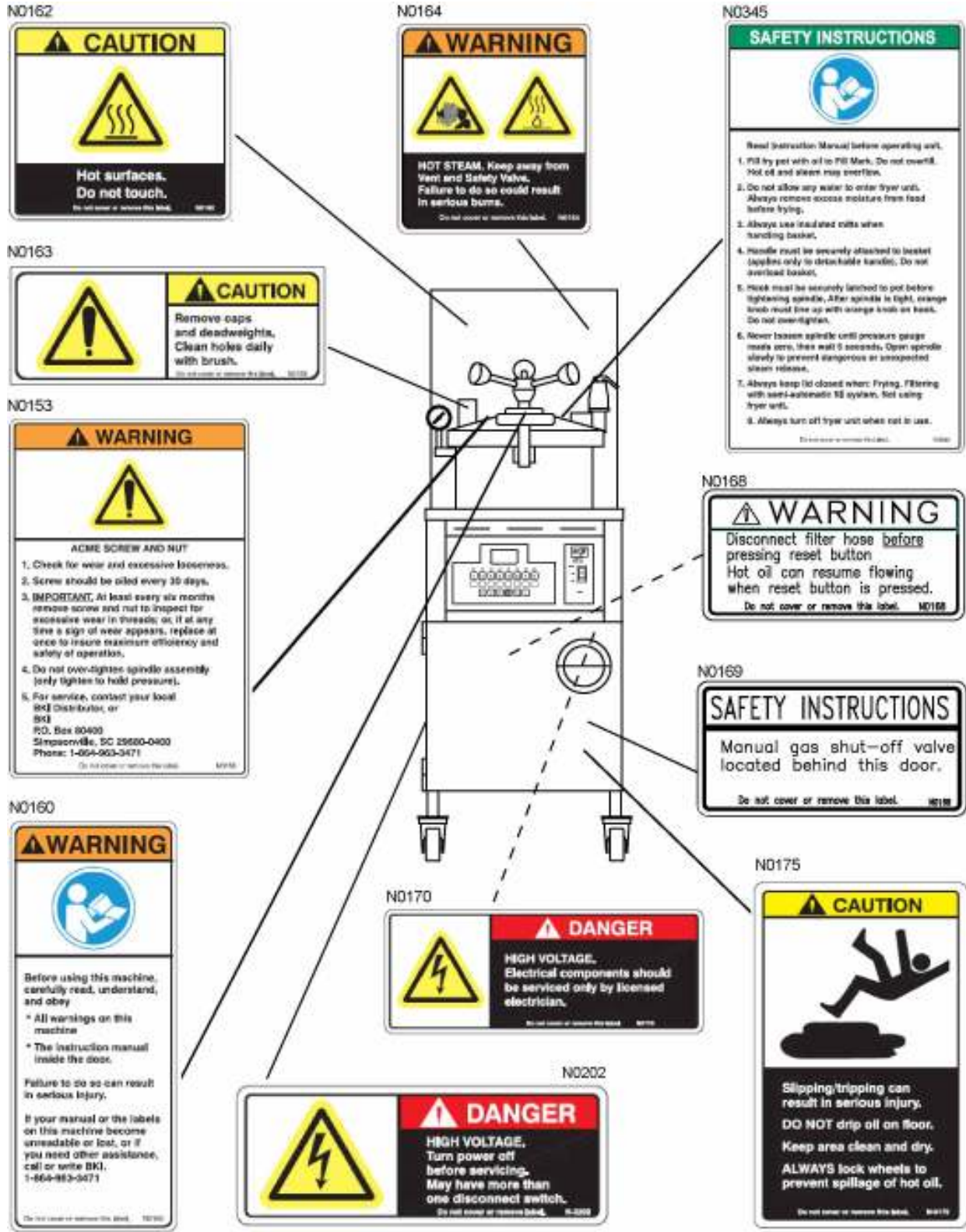

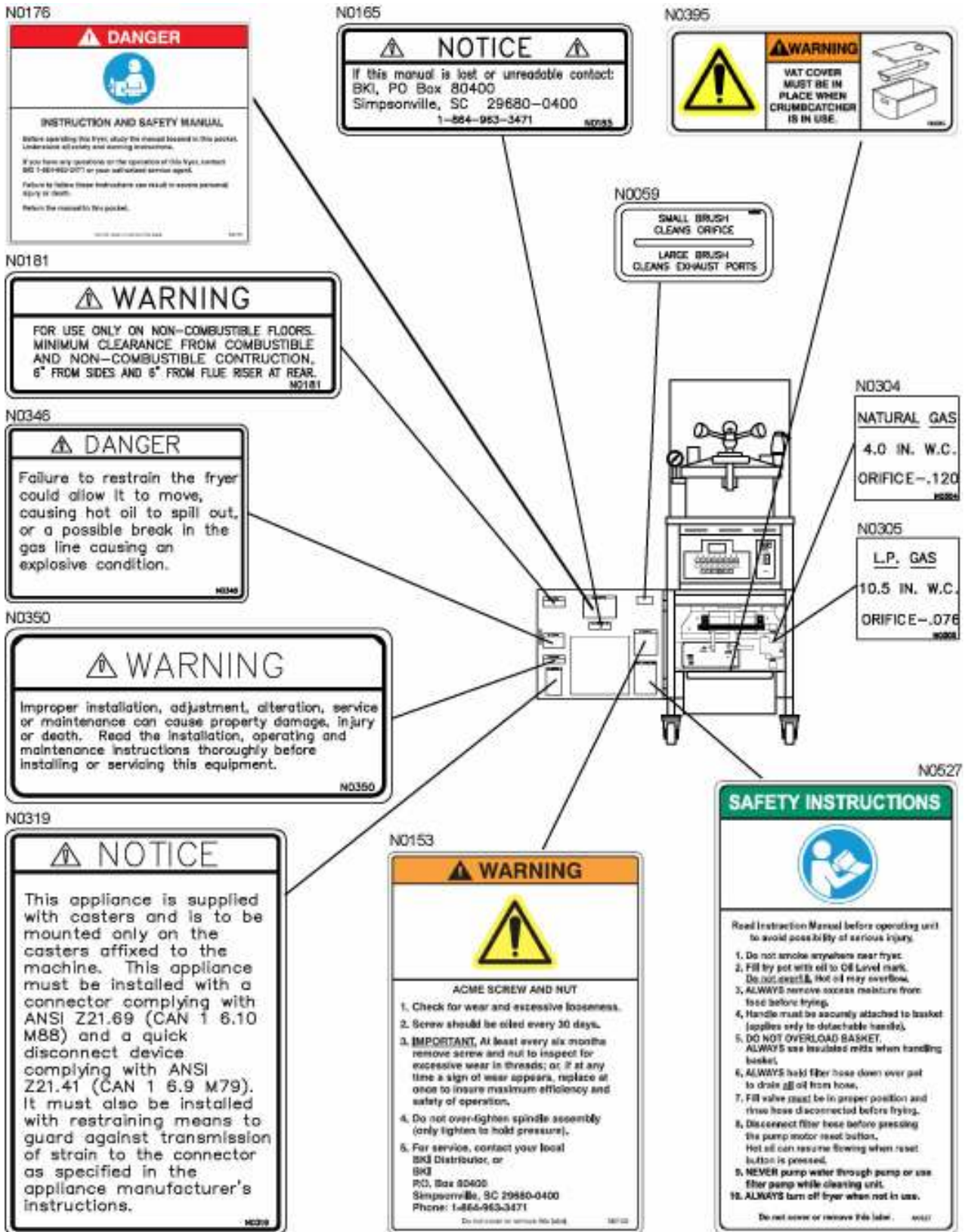

Installation

For installation information, refer to *Gas Pressure Fryer, MODELS LGF, LGF-F, & LGF-FC, Installation and Operation Manual LI0101*.

Operation

Controls and Indicators

Refer to the figure and table below for an explanation of the fryer's controls and indicators.

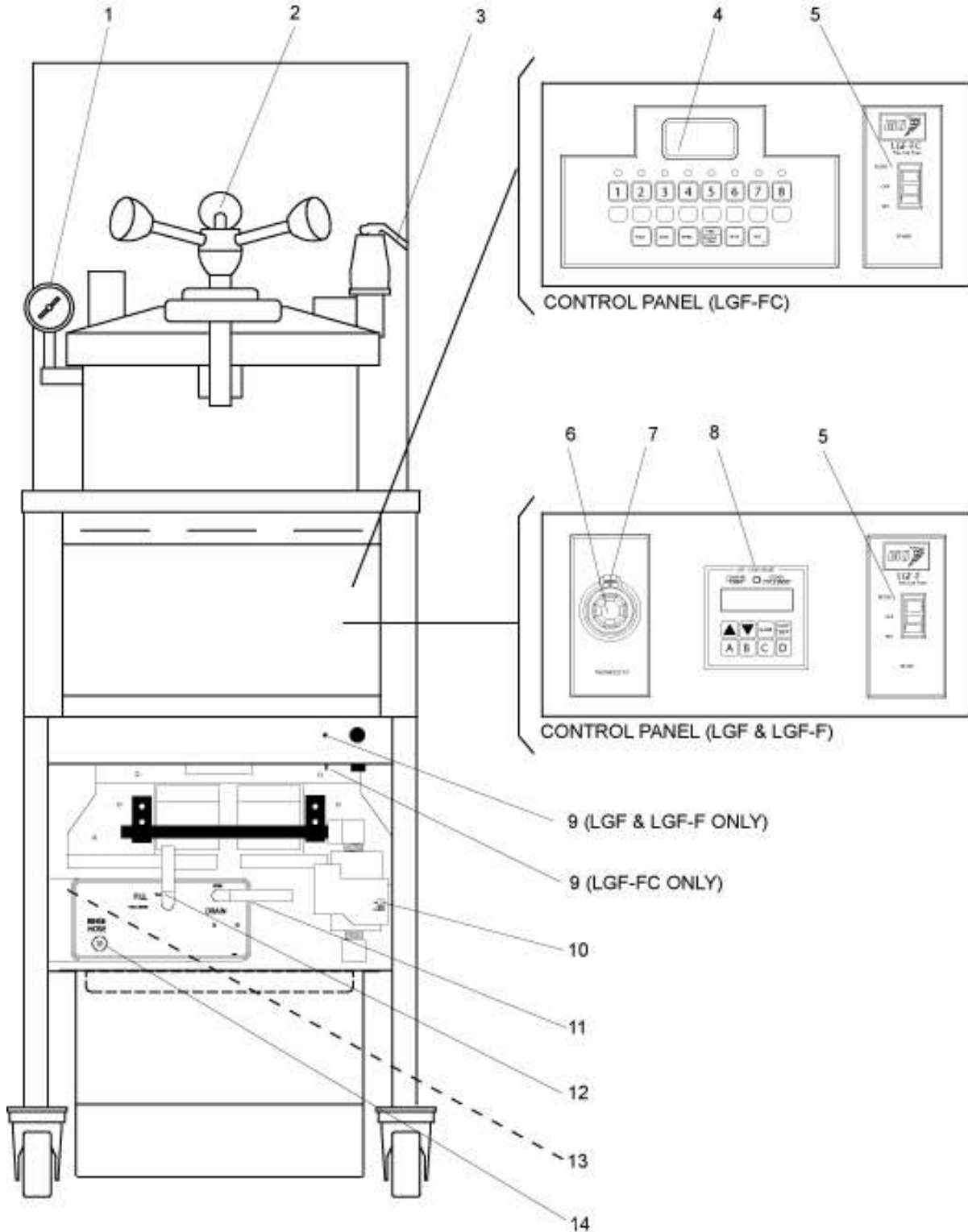

Item	Description	Function
1	Pressure Gauge	Indicates the pressure inside the pot.
2	Spin Handle	Used to tighten the lid to the pot once it is latched.
3	Pop Safety Valve lever	Used to release pressure periodically to prevent the seat from sticking.
4	Computer	Used to set and activate product programs.
5	Rocker Switch	FILTER – When placed in this position, power is applied to the motor and shorting is pumped into the pot directly or thru the fill hose. OFF – When placed in this position, power is removed from both the pump motor and gas system. FRY – When placed in this position, power is supplied to the thermostat and gas system.
6	Thermostat Knob	Used to set the temperature of the shortening.
7	Thermostat Light	Illuminates when the thermostat calls for heat. Extinguishes when the shortening temperature is reached.
8	Digital Timer	The digital timer consists of an LED, display, beeper and 8 buttons described below:
	LED indicator	Prior to the start of a timing cycle the LED will be OFF. When running a timing cycle the LED will flash. At the end of a timing cycle the LED will turn ON steady. When idle the LED is off.
	TIME SELECT (2 arrow buttons)	Two arrow buttons on the front panel are used to set the time. Hold the UP ARROW button down to increase the time. The longer the button is held down, the faster the rate at which the time will increase. The DOWN ARROW button is used in the same manner as the UP ARROW button except it will cause the time to decrease. The time is increased or decreased in 30-second increments.
	START/STOP button	Starting the Timer - Pressing this button while the timer is not active will cause the timer to begin counting down the time on the display. Stopping the Timer - Pressing this button while the timer is active will stop the timer from counting down and display the remaining time. Time cannot be changed with the TIME SELECT buttons at this point. If this button is pressed again the timer will continue counting down from the point it was stopped. Resetting the Timer - Pressing and holding this button for longer than two (2) seconds will reset the timer and the display will return to the original starting time. At this point, time can be changed using the TIME SELECT buttons or the preset buttons. Canceling The STIR OIL Function - Pressing this button cancels the STIR OIL function while it is active.
	ALARM button	This button allows the user to set an elapsed time at which the internal alarm will sound during a cycle. The time is set by pressing and holding the ALARM button while using the UP and DOWN arrows to change the time. The controller will limit the alarm time to be less than the currently programmed interval cycle time. The default alarm time is 0:00 which disables it. The ALARM time is saved on power down in the same manner as the last interval time. When a time cycle is running and the alarm time has elapsed the internal alarm will sound for 10 seconds. For example, a cycle time 10:00 and alarm time of 2:00 would cause the alarm to sound for 10 seconds once the controller has counted down from 10:00 to 8:00. This button is used to cancel the STIR OIL alarm. This button is also used to reconfigure the STIR OIL Function.

Item	Description	Function
8	A, B, C, D preset buttons	These buttons are used to save and recall preset cycle and alarm times, saving operator time and minimizing error when changing interval cycle times and alarm times. To save the current interval and alarm times into one of the preset locations, press and hold the A, B, C, or D preset button for 2 seconds and the controller will double chirp to indicate the times have been saved. To recall any preset time, press and quickly release the appropriate button and the time values are loaded and displayed. These buttons are also used to reconfigure the STIR OIL function.
	Beeper	A beeper sounds when the timer counts down to 0. Pressing the START/STOP button stops the beeper and resets the timer causing the display to return to the original starting time. At this point, time can be changed using the TIME SELECT buttons or the preset buttons. The beeper will also sound for 10 seconds if the alarm time has elapsed during a timing cycle. When the STIR OIL function begins the beeper will sound until the ALARM or START/STOP button is pressed.
	Display	Used to display the time. It also displays the words "STIR" then "OIL" in .5 second intervals until the ALARM or START/STOP button is pressed.
9	High Limit Reset Switch	If shortening inside the pot reaches an unsafe temperature, power is automatically removed from the control panel and the gas system shuts off. Pressing this switch returns power to the control panel and resets the gas system.
10	Gas Control Valve Switch	ON – Allows gas to flow when the FILTER/OFF/FRY switch is set to the FRY position and the thermostat calls for heat. OFF – Prevents gas flow regardless of FILTER/OFF/FRY switch and thermostat settings.
11	Drain Lever	DRAIN OPEN – When placed in this position, the drain valve opens and shortening drains into the vat. Also power is removed from the control panel and gas system. DRAIN CLOSED – When placed in this position, the drain valve is closed to prevent shortening from draining into the pot. Also power is restored to the control panel and gas system.
12	Fill Lever	FILL THRU POT – When placed in this position, shortening will be pumped from the vat to the pot if the rocker switch is in the FILTER position. FILL THRU HOSE – When placed in this position, shortening will be pumped from the vat to the pot via a fill hose if the rocker switch is in the FILTER position.
13	Pump Motor Reset Switch	If the motor overheats while filtering, it will automatically shut off. Wait 15 minutes to allow motor to cool before pressing this switch.
14	Rinse Hose Connector	Used to connect the Rinse hose for cleaning and refilling the pot.

Care of the Shortening

Solid shortening should always be returned to the filter vat while in the liquid state. If this is not done, it will have to be heated to a liquid state. When using solid shortening, the fryer must be equipped with a pump heater. After filtering with solid shortening, the filter lines must be completely emptied of shortening. The pump heater will take care of any residual shortening in the pump, but cannot melt all of the shortening in the filter lines. The pump heater accessory may be purchased separately from BKI.

To extend the life of your shortening, for the best possible flavor in your products, and for economy and efficiency of operation, we urge you to follow these recommendations:

1. Use only high-quality frying shortening without additives, of low moisture content and with a high smoke point.
2. Press excess moisture from products before breading. The more moisture released in the shortening, the quicker it will break down.
3. Filter at least once a day or once every three loads during frequent cooking.
4. Clean any residue or crust formations from the sides and bottom of the pot each time you filter the shortening.
5. Add fresh shortening as needed to maintain the proper shortening level **TO THE FILL MARK ON THE POT WALL**.
6. **DO NOT HOLD SHORTENING AT HIGH TEMPERATURE** when the fryer is not in use. If you expect an elapsed time of one hour or more between cooking, close the lid and press the "0" button on the LGF-FC model. On Models LGF and LGF-F, set the thermostat to 150° F.
7. Shortening changes are determined by the quantity and type of food prepared. Excessive boiling and foaming are definite signs of shortening breakdown.
8. After you have finished frying for the day, filter the shortening and replace the filter pad. Also, thoroughly clean the pot of sediment and crumbs and empty the condensate pan.

LGF and LGF-F Operation

Start-Up (LGF and LGF-F)

1. Make sure the main drain valve is closed.
2. Fill pot with shortening to about one inch below the fill mark.

WARNING

Risk of fire exists if the oil level drops below the minimum oil level. The level of oil within the pot must not fall below 5mm of the maximum oil level.

WARNING

Use of oil/shortening older than the manufacturers recommendations for life of the oil is prone to surge boiling and flash fires. Follow the oil manufacturers guidelines for lifecycle of oil/shortening.

CAUTION

Overfilling the fryer pot with shortening could lead to serious injury. Ensure that the fryer pot is filled with shortening only to the fill mark when shortening is hot. Do not use any shortening other than what is specified in this manual and do not overfill the fryer pot.

CAUTION

The LGF/LGF-F fryer has a maximum temperature setting of 375° F (190° C). Do not use oil/shortening with a flashpoint less than 554° F (290° C)

NOTICE

Use only high-quality shortening that has low moisture content, a high smoke point and no additives.

3. Place the gas control **ON/OFF** switch in the **ON** position.
4. The digital timer has a STIR OIL function that operates in one of four reconfigurable modes. If the timer needs to be reconfigured, follow step a. If the timer does not need to be reconfigured, follow step b.
 - a. Press and hold the ALARM button and at the same time place the **FILTER/OFF/FRY** switch in the **FRY** position. The display will show the word "STIR" until the ALARM button is released. When the button is release the display will show the current configuration mode. To change this mode select the timer key that represents the mode you want. Refer to the table below:

KEY	DISPLAY	MODE DESCRIPTION
A	-AL-	New or unchanged timer. Alarm sounds at the end of the internal 6 minute countdown.
B	-OFF	Defeats the STIR OIL function. Timer operates as if it had no STIR OIL function.
C	PrES	STIR OIL function for all Pressure Fryers.
D	LiFT	STIR OIL function for all Autolift Fryers.

The display will now show the selected mode. Proceed to step c.

- b. Once the fryer is filled with shortening, place the **FILTER/OFF/FRY** switch in the **FRY** position.
- c. Unless the STIR OIL function is operating in the –OFF mode, the digital timer activates a STIR OIL function and begins an internal six minute countdown (not displayed). At the end of the internal countdown, the display shows the words "STIR" then "OIL" in .5 second intervals and the alarm sounds. Depress the ALARM button and stir the shortening freely while it is heating.

IMPORTANT! Before the first cooking operation each day, stir the shortening freely while it is heating to provide a balanced shortening temperature for excellent results with the first cooking. Failure to do this can result in a crusty skin on the product surface with an undercooked product internally. In addition, in some cases, failure to stir the shortening while it is initially heating may cause the HI-LIMIT safety device to disable the power due to a false overtemperature condition.
5. Set the thermostat to the desired cook temperature. The temperature light will go on. When the temperature is reached, the light will go off. The light will continue to cycle on and off as the fryer maintains the set temperature.
6. Press and hold the **TIME SELECT** arrow buttons on the digital timer until the desired cook time is displayed or recall a preset time by quickly pressing the appropriate preset button.
7. The shortening will heat and begin to reach the fill mark inside the pot. Add more shortening as required to reach the fill mark.

Cooking (LGF and LGF-F)**WARNING**

Do not open the drain valve or the fill valve while the fryer is under pressure. Serious burns may result.

1. Ensure that the Start-Up procedures have been performed.

2. When frying chicken, connect the basket handle and lower the basket into the shortening in the fryer pot.

⚠ WARNING Hot shortening may splash out of the pot causing severe injury when dropping chicken into pot. Carefully drop pieces of chicken into pot to prevent shortening splashes.

3. Carefully drop the chicken in the shortening one piece at a time starting with thighs and drumsticks. The fryer is designed to accommodate 32 pieces of chicken.

⚠ DANGER Failure to use the insulated mitts will result in severe injury. Always use the insulated mitts when handling the hot fry basket.

4. Lift the basket approximately 2 to 3 inches (6.35 cm.) above the shortening and shake it. This keeps the food from sticking together and causing white spots on the cooked food.

⚠ WARNING Hot shortening may splash out of the pot causing severe injury when lowering basket into pot. Carefully lower basket into pot to prevent shortening splashes.

5. Slowly lower the fryer basket into fryer pot and remove the detachable handle.
6. Close the lid. Make sure the lid hook latches securely under the catch.
7. Tighten the spin handle until the lid is firmly sealed. Then line up the orange knob on the spin handle with the orange knob at the front of the fryer.
8. Activate the timer by pressing the **START/STOP** button on the digital timer. The timer will begin the count down.
9. At the end of the frying cycle, the digital timer beeper will sound and the fryer will automatically release pressure into the baffle box. Press the **START/STOP** button.
10. When the pointer on the pressure gauge is at zero, wait 5 seconds then slowly turn the spin handle counterclockwise to break the seal around the lid. The fryer has a locking pin that prevents turning the spin handle until the pressure drops to zero. Do not force the spin handle to open the lid.
11. Slowly open the lid.

⚠ DANGER Failure to use the insulated mitts will result in injury. Always use the insulated mitts when handling the hot fry basket.

12. Connect the basket handle then lift the basket and hang it on the front of the fryer pot to drain.
13. Empty the basket.
14. Remember to filter the shortening at least every third frying cycle load. Refer to the procedure in this manual. Also filter the shortening and clean the fryer at the end of each day. If you do not plan to use the fryer for an hour or more, turn the thermostat down to 150° F and close the lid.
15. When you have finished frying for the day, turn the **FILTER/OFF/FRY** switch to the **OFF** position.
16. Place the gas control **ON/OFF** switch in the **OFF** position.

LGF-FC Operation

System Programming

Use the following figure and table to set options that apply to each product programs.

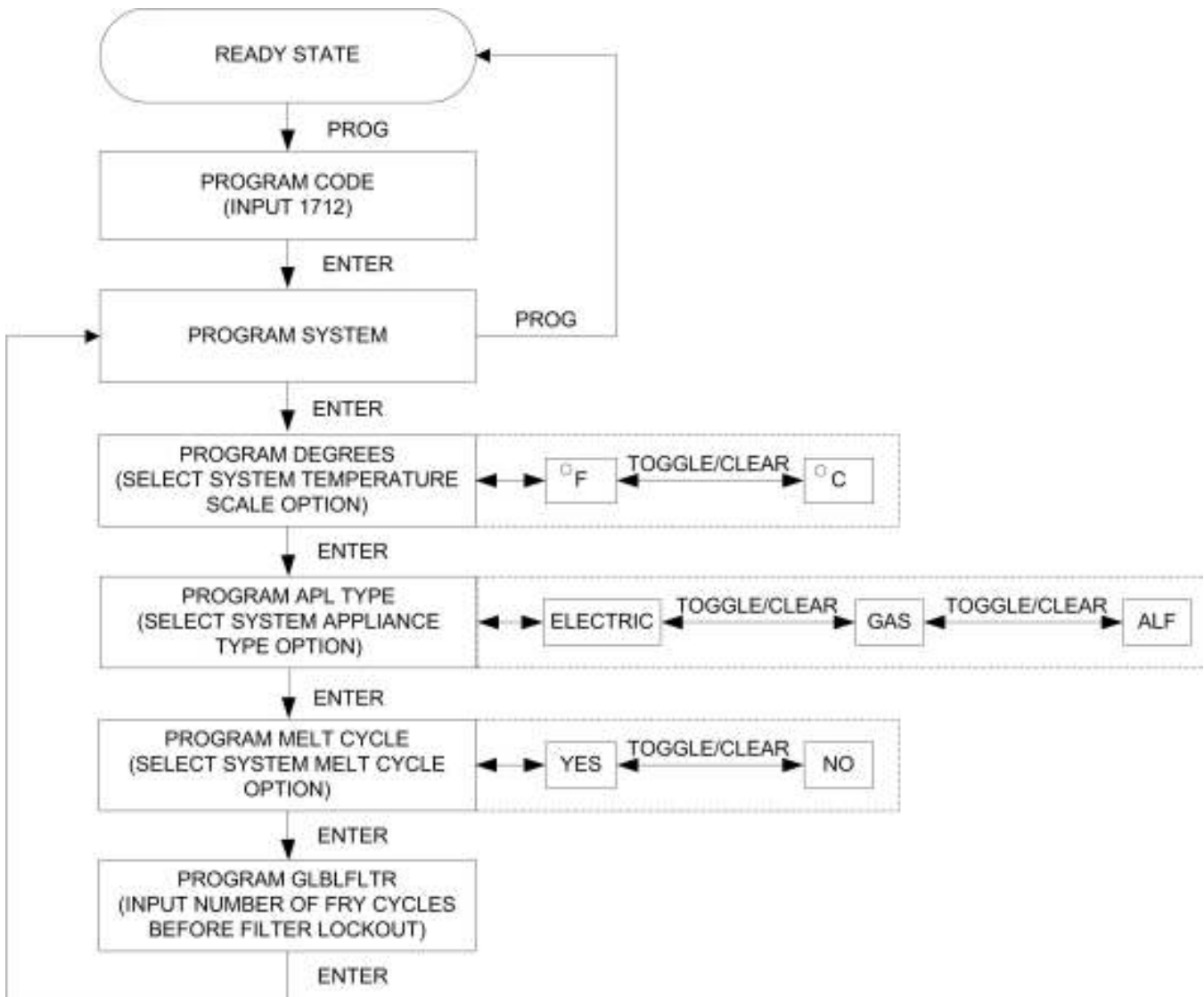

Figure 1. System Programming Sequence

Table 1. System Programming Procedure

STEP	ACTION	DISPLAY	COMMENTS
1	Press the FILTER/OFF/FRY switch to FRY .	LOW	
2	Press PROG on the keypad.	PROGRAM CODE	
3	Input 1712 and ENTER.	PROGRAM SYSTEM	
4	Press ENTER.	PROGRAM DEGREES °F	This command allows you to choose the temperature scale option you want to use. The display will show either show °F or °C.
5	Press TOGGLE/CLEAR until the desired option is displayed.	PROGRAM DEGREES X	X refers to the temperature scale you have chosen.
6	Press ENTER.	PROGRAM APL TYPE GAS	This command allows you to choose the appliance type you are using. The display may show ELECTRIC, GAS OR ALF.
7	Press TOGGLE/CLEAR until the desired option is displayed.	PROGRAM APL TYPE X	X refers to the appliance type you have chosen.
8	Press ENTER.	PROGRAM MELTCYCL YES	This command allows you to set the melt cycle option. This is normally set to yes if you are using solid shortening. The display will show either YES or NO.
9	Press TOGGLE/CLEAR until the desired option is displayed.	PROGRAM MELTCYCL X	X refers to the melt cycle option chosen.
10	Press ENTER.	PROGRAM GLBLFLTR 0	This command allows you to specify the total number of fry cycles to complete among all product programs before a message is displayed reminding you to filter the shortening (filter lockout).
11	Press TOGGLE/CLEAR and input the number of fry cycles you want to complete among all product programs before enabling filter lockout.	PROGRAM GLBLFLTR X	X refers to the number of program cycles you want to complete among all product programs before filtering the shortening.
12	Press ENTER.	PROGRAM SYSTEM	
13	Press PROG to exit the programming mode.	LOW	

Table 2. Product Programming Procedure

STEP	ACTION	DISPLAY	COMMENTS
1	Press the FILTER/OFF/FRY switch to FRY .	LOW	
2	Press PROG on the keypad.	PROGRAM CODE	
3	Input 1724 and press ENTER.	PROGRAM PRODUCT #	
4	Select the program product number (1-8).	PROGRAM PRODUCT X	X refers to the program number you selected.
5	Press ENTER.	PROGRAM TIME1 00:00	This command allows you to specify the cooking time for this stage. The time displayed may be a previously programmed value.
6	Press TOGGLE/CLEAR and input the number of minutes you want to cook.	PROGRAM TIME1 XX:XX	XX:XX refers to the number of minutes you input.
7	Press ENTER.	PROGRAM TEMP1 000 °F	This command allows you to specify the cooking temperature for this stage. The temperature displayed may be a previously programmed temperature. The temperature scale may also display °C depending on the system option that is set.
8	Press TOGGLE/CLEAR and input the cooking temperature for product to be cooked.	PROGRAM TEMP1 XXX °F	XXX refers to the cooking temperature you input.
9	Press ENTER.	PROGRAM TEMPCOM1 FLEX TIME	This command enables you to select whether or not time is allowed for the fryer to recover from temperature loss while cooking during this stage. The FLEX TIME option will allow the fryer to recover from temperature loss.
10	Press TOGGLE/CLEAR until the desired option is displayed.	PROGRAM TEMPCOM1 X	X refers to the temperature compensation option selected.
11	Press ENTER.	PROGRAM VALVE1 CLOSED	This command allows you to specify whether the solenoid valve will be open or closed during this stage.
12	Press TOGGLE/CLEAR until the desired option is displayed.	PROGRAM VALVE1 X	X refers to the solenoid valve option selected. OPEN is used for Models ALF and BLF Automatic Lift fryers. If your program requires the solenoid valve to be closed while cooking, choose the CLOSED option.

STEP	ACTION	DISPLAY	COMMENTS
13	Repeat steps 5-12 when programming stages 2, 3, 4 and 5 for Electric and Gas appliance types. Repeat steps 5-10 when programming stages 2, 3, 4 and 5 for an ALF appliance type.		The time and temperature of each stage has to be less than the preceding stage.
14	Press ENTER.	PROGRAM PREALARM 00:00	This command allows you to specify the number of minutes before the end of the cooking time (for each stage) until the alarm sound. The prealarm value displayed may be a previously programmed value.
15	Press TOGGLE/CLEAR and input the prealarm minutes.	PROGRAM PREALARM XX:XX	XX:XX refers to the prealarm minutes you input.
16	Press ENTER.	PROGRAM FILTER 0	This command allows you to specify the number of fry cycles you want to complete for this program before a message is displayed reminding you to filter the shortening (filter lockout). The filter value displayed may be a previously programmed value.
17	Press TOGGLE/CLEAR and input the number of fry cycles you want to complete before enabling filter lockout.	PROGRAM FILTER X	X refers to the number of program cycles you want to complete before filtering the shortening.
18	Press ENTER.	PROGRAM PRODUCT #	
19	If you wish to input more programs, proceed by pressing the next program number and follow steps 5 through 18 or press PROG to exit the programming mode.		

Start-Up (LGF-FC)

1. Make sure the main drain valve is closed.
2. Fill pot with shortening to about one inch below the mark.

WARNING

Risk of fire exists if the oil level drops below the minimum oil level. The level of oil within the pot must not fall below 5mm of the maximum oil level.

WARNING

Use of oil/shortening older than the manufacturers recommendations for life of the oil is prone to surge boiling and flash fires. Follow the oil manufacturers guidelines for lifecycle of oil/shortening.

CAUTION

Overfilling the fryer pot with shortening could lead to serious injury. Ensure that the fryer pot is filled with shortening only to the fill mark when shortening is hot. Do not use any shortening other than what is specified in this manual and do not overfill the fryer pot.

CAUTION

The LGF-FC fryer has a maximum temperature setting of 390° F (200° C). Do not use oil/shortening with a flashpoint less than 554° F (290° C)

NOTICE

Use only high-quality shortening that has low moisture content, a high smoke point and no additives.

3. Place the gas control **ON/OFF** switch in the **ON** position.
4. Place the **FILTER/OFF/FRY** switch to the **FRY** position. The question "Is the Fry Pot filled – If yes press ENTER" will appear on the computer display. The shortening will heat and begin to reach the fill mark inside the pot.
5. Add more shortening as required to reach the fill mark. Once the oil reaches the fill mark, press the **ENTER** button. The computer will display "STIR OIL" and automatically enter the STIR OIL mode. In this mode the computer will heat the oil to 255°F and hold that temperature.
6. Stir the oil freely while it is heating. Press the **0** button when finished stirring the oil.

IMPORTANT! Before the first cooking operation each day, stir the shortening freely while it is heating to provide a balanced shortening temperature for excellent results with the first cooking. Failure to do this can result in a crusty skin on the product surface with an undercooked product internally. In addition, in some cases, failure to stir the shortening while it is initially heating may cause the HI-LIMIT safety device to disable the power due to a false overtemperature condition.

Cooking (LGF-FC)

1. Ensure that the Start-Up procedures have been performed.
2. Press the desired program number on the keypad. The computer will still display "**LOW**". The fryer will begin to heat to the temperature that has been factory preset. When "**READY**" appears on the display, the fryer is up to the desired temperature and the product can be loaded.
3. When frying chicken, connect the basket handle and lower the basket into the shortening in the fryer pot.

WARNING

Hot shortening may splash out of the pot causing severe injury when dropping chicken into pot. Carefully drop pieces of chicken into pot to prevent shortening splashes.

- Carefully drop the chicken in the shortening one piece at a time starting with thighs and drumsticks. The fryer is designed to accommodate 32 pieces of chicken.

⚠ DANGER

Failure to use the insulated mitts will result in severe injury. Always use the insulated mitts when handling the hot fry basket.

- Lift the basket approximately 2 to 3 inches (6.35 cm.) above the shortening and shake it. This keeps the food from sticking together and causing white spots on the cooked food.

⚠ WARNING

Hot shortening may splash out of the pot causing severe injury when lowering basket into pot. Carefully lower basket into pot to prevent shortening splashes.

- Slowly lower the fryer basket into fryer pot and remove the detachable handle.
- Close the lid. Make sure the lid hook latches securely under the catch.
- Tighten the spin handle until the lid is firmly sealed. Then line up the orange knob on the spin handle with the orange knob at the front of the fryer.
- Press the desired program number a second time. The red light above the program number will flash and the computer will display "**COOK**". This will start a countdown in minutes and seconds until the end of the cycle.
- At the end of the cooking cycle, the computer will display "**DONE**" and signal with a series of audible "beeps". Press the selected number once again to stop the cook cycle. Fifteen seconds before the end of the cook cycle, the program will automatically release the pressure from the fryer. For your safety, the lid will not unlock, even at the end of the cook cycle, until the pressure has been fully released.

⚠ WARNING

Hot steam will escape when you open the lid possibly causing severe injury. Keep your face and arms away from the fry pot.

- Slowly turn the spin handle counterclockwise to break the seal around the lid. Your fryer has a locking pin that prevents turning the spin handle until the pressure drops to "0".
- Slowly open the lid.

⚠ DANGER

Failure to use the insulated mitts will result in injury. Always use the insulated mitts when handling the hot fry basket.

- Connect the basket handle then lift the basket and hang it on the front of the fryer pot to drain.
- Empty the basket.
- Remember to filter the shortening at least every third frying cycle load. Refer to the procedure in this manual. Also filter the shortening and clean the fryer at the end of each day.
- Close the lid and press the **0** button. **Idle 255°F** will display. This will automatically hold the shortening at a cooler temperature.
- To escape the idle mode, press the **0** button again and the fryer will heat to its original temperature.
- When you have finished frying for the day, turn the **FILTER/OFF/FRY** switch to the **OFF** position.
- Place the gas control **ON/OFF** switch in the **OFF** position.

Recipes

Fried Onion Rings

1. Take frozen onion rings from freezer or bread fresh onion rings with Imperial breading.
2. Place onion rings into fryer basket.
3. Close cover to begin pressure frying.
4. Cook for 4 minutes at 350°F for frozen product.

OR

5. Cook for 3 minutes at 350°F for fresh product.

Potato Wedges

1. Wash and cut potatoes.
2. Season and bread each stick with Imperial breading.
3. Place potato wedges into fryer basket.
4. Close cover to begin pressure frying.
5. Cook for 7 to 8 minutes at 325°F depending on size.

French Fries

1. Take frozen french fries from freezer or wash and cut fresh potatoes.
2. Place french fries into fryer basket.
3. Close cover to begin pressure frying.
4. Cook for 4 to 6 minutes at 325°F depending on size.

Fresh Chicken

Use fresh 8 or 9-piece cut chicken. Use 2-1/2 to 3 pounds for best results.

1. Rinse product under cold water.
2. Bread each piece with Imperial breading.
3. Place product into fryer basket.
4. Close the cover to begin pressure frying.
5. Cook for 12 minutes at 325°F.

Frozen Chicken (MRB) except wings

1. Take product from freezer.
2. Place product into fryer basket.
3. Cook for 3 minutes (open) at 325°F.
4. Add wings to fryer basket.
5. Close the cover to begin pressure frying.
6. Cook for 17 minutes at 325°F.

Fresh Chicken Wings

1. Rinse product under cold water.
2. Bread each piece with Imperial breading.
3. Place product into fryer basket.
4. Close cover to begin pressure frying.
5. Cook for 12 minutes at 325°F.

Chicken Wings (Frozen - 5 kilograms or 10 pounds)

1. Take product from freezer.
2. Place wings into fryer basket.
3. Close cover to begin pressure frying.
4. Cook for 8 minutes at 325°F or 9½ to 10 minutes at 320°F.

Chicken Drummettes

1. Take product from freezer.
2. Place drummettes into fryer basket.
3. Close cover to begin pressure frying.
4. Cook for 9 to 11 minutes at 325°F.

Whole Turkey (12 to 14 pounds)

1. Rinse and bread turkey with Imperial breading.
2. Place turkey into fryer basket.
3. Close cover to begin pressure frying.
4. Cook for 45 to 55 minutes at 300°F.

Whole Duckling

1. Rinse and bread duck with Imperial breading.
2. Place duck into fryer basket.
3. Close cover to begin pressure frying.
4. Cook for 20 to 25 minutes at 300°F.

Pork Chops

1. Bread each chop with Imperial breading.
2. Place pork chops into fryer basket.
3. Close cover to begin pressure frying.
4. Cook for 8 to 10 minutes at 325°F depending on size.

Cube Or Minute Steaks

1. Bread each steak with Imperial breading.
2. Place steaks into fryer basket.
3. Close cover to begin pressure frying.
4. Cook for 2 to 4 minutes at 325°F depending on size.

Milanese

It is best to use 5 to 7 ounce beef steaks.

1. Season and bread each steak as desired.
2. Place steaks into fryer basket.
3. Close cover to begin pressure frying.
4. Cook for 5 to 6 minutes at 325°F depending on size.

Fresh Shrimp

1. Season and bread shrimp as desired.
2. Place shrimp into fryer basket.
3. Close cover to begin pressure frying.
4. Cook for 2½ to 3½ minutes at 350°F depending on size.

Fresh Fish or Frozen Fish

For best results, use a tiered basket. The best fish for frying are Flounder, Cod, Walleyed Pike, or any other popular frying fish.

1. Bread each piece of fish as desired.
 2. Place fish in tiered basket.
 3. Close cover to begin pressure frying.
 4. Cook for 5 to 7 minutes at 325°F depending on size for fresh fish.
- OR
5. Cook for 8 to 10 minutes at 325°F depending on size for frozen fish.

Corn On The Cob

Corn can be fried either plain or breaded.

1. Take frozen corn ears from freezer and rinse.
2. Bread with Imperial breading as desired.
3. Place corn ears into fryer basket.
4. Close cover to begin pressure frying.
5. Cook for 6 to 8 minutes at 325°F depending on size.

Egg Rolls (frozen)

1. Take egg rolls from freezer.
2. Place egg rolls into basket.
3. Close the cover to begin pressure frying.
4. Cook for 6 to 8 minutes at 325°F depending on size.

Operation After Gas or Power Outage

The fryer may shut off automatically if the gas supply is interrupted or the power goes out. If either of these conditions occur you should perform the following procedure:

WARNING

For your safety, if the gas supply stops, or, if the power goes out, make sure to wait for at least five minutes before restarting your fryer. This allows time for any unburned gas to dissipate. (LP gas may take longer than five minutes.) If you smell gas, do not start your fryer.

1. Place the gas control **ON/OFF** switch in the **OFF** position.
2. Place the **FILTER/OFF/FRY** switch in the **OFF** position.
3. Wait at least five minutes to allow any gas that may have accumulated in the burner compartment to escape.
4. Follow normal operating procedures once the power or gas is restored.

Normal Shutoff

1. Place the **FILTER/OFF/FRY** switch in the **OFF** position.
2. Place the gas control **ON/OFF** switch in the **OFF** position.
3. Wait at least five minutes to allow any gas that may have accumulated in the burner compartment to escape.

Maintenance

For maintenance information, refer to *Gas Pressure Fryer, MODELS LGF, LGF-F, & LGF-FC, Installation and Operation Manual LI0101*.

Replacement Parts

Use the information in this section to identify replacement parts. To order replacement parts, call your local BKI sales and service representative. Before calling, please note the serial number, model number and voltage on the rating tag affixed to the unit.

Assemblies

Description	Assembly #	Figure #	Table #
LID/ARM ASSEMBLY	AN3211350S	Figure 3	Table 3
DEAD WEIGHT & PRESSURE GAUGE ASSEMBLY	N/A	Figure 4	Table 4
DRAIN/MOTOR/PIPING ASSEMBLY	N/A	Figure 5	Table 5
GAS BURNER TRAY ASSEMBLY (LP) GAS BURNER TRAY ASSEMBLY (NATURAL)	SB3467 SB3466	Figure 6	Table 6
CONTROL/INSULATION PANEL LGF 220/60/1 CONTROL/INSULATION PANEL LGF-F 110/220/50/1 CONTROL/INSULATION PANEL LGF-F 220/380/50/1 CONTROL/INSULATION PANEL LGF-F 220/60/1 CONTROL/INSULATION PANEL LGF-F 240V CONTROL/INSULATION PANEL LGF-F	SB3489 SB3493 SB3337B SB3495 SB3458 SB3326A	Figure 7	Table 7
CONTROL/INSULATION PANEL LGF-FC CONTROL/INSULATION PANEL LGF-FC 240V ENG CONTROL/INSULATION PANEL LGF-FC ARGENTINA CONTROL/INSULATION PANEL LGF-FC KOREA	SB3483 SB3457 SB3483B SB3483A	Figure 8	Table 8
DOOR ASSEMBLY W/POCKET	SB3290	Figure 9	Table 9
OIL VAT ASSEMBLY	AN32112800	Figure 10	Table 10
OUTLET BOX ASSY, LGF OUTLET BOX ASSY, LGF-F	SB3342 SB3343	Figure 11	Table 11
SOLENOID VALVE 120V SOLENOID VALVE 240V	SB3344 SB3335	Figure 12	Table 12
QUICK DISCONNECT ASSEMBLY	SB1997S	Figure 13	Table 13
DRAIN VALVE & PLUGS	SB1999S	Figure 14	Table 14

Figure 3. Lid/Arm Assembly, AN3211350S (Sheet 1 of 4)

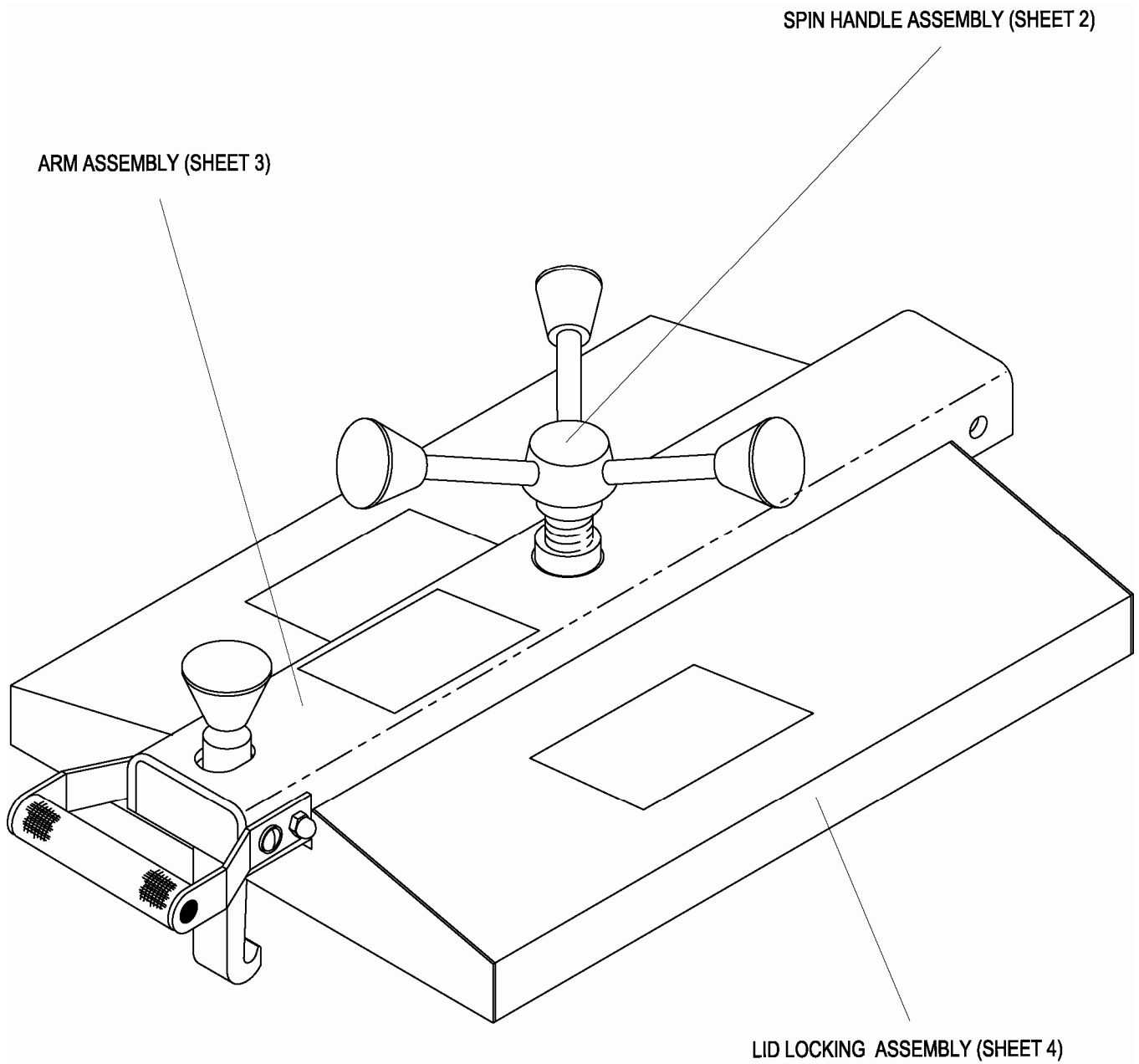

Figure 3. Lid/Arm Assembly, AN3211350S (Sheet 2 of 4)

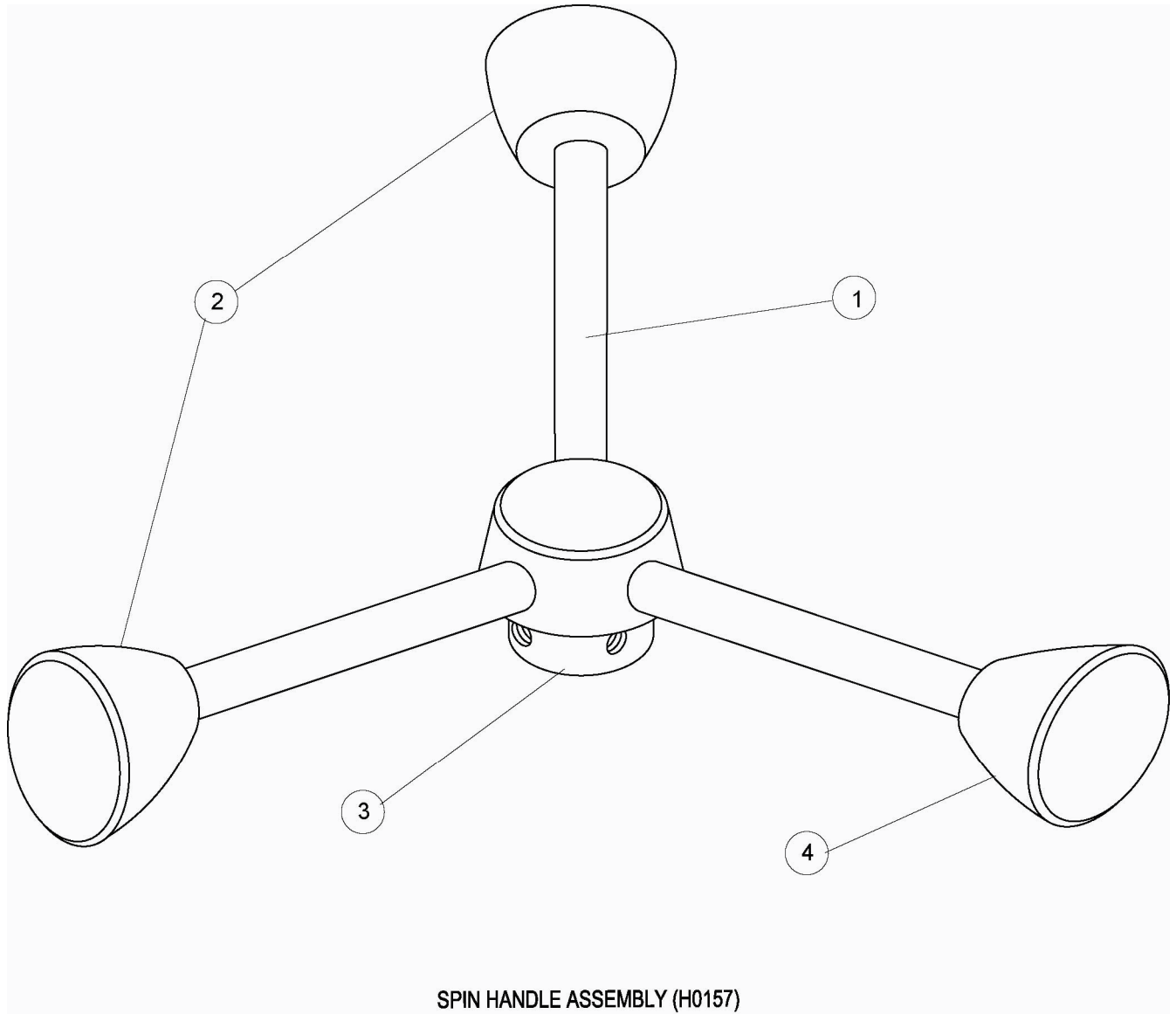

Figure 3. Lid/Arm Assembly, AN3211350S (Sheet 3 of 4)

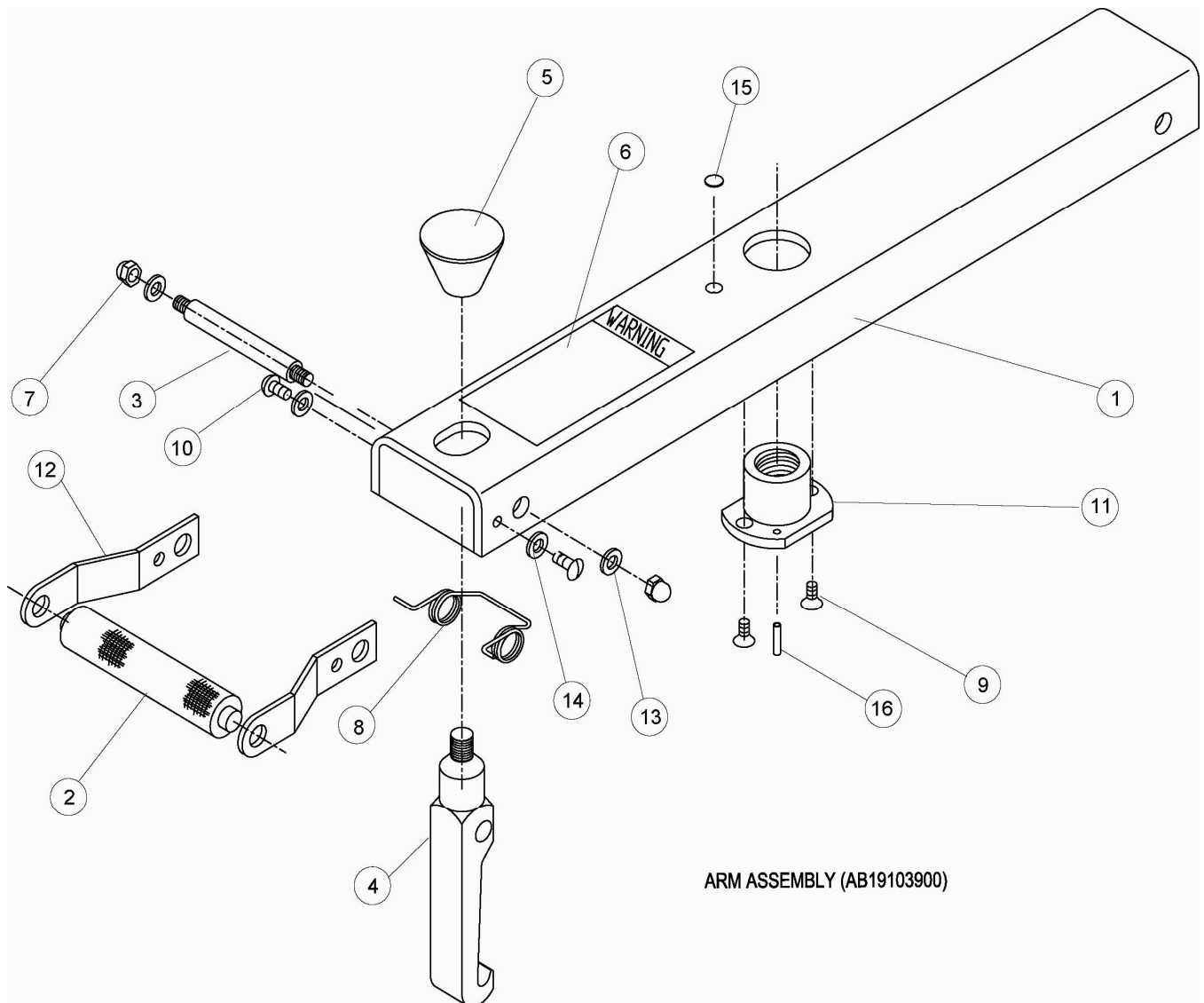

Figure 3. Lid/Arm Assembly, AN3211350S (Sheet 4 of 4)

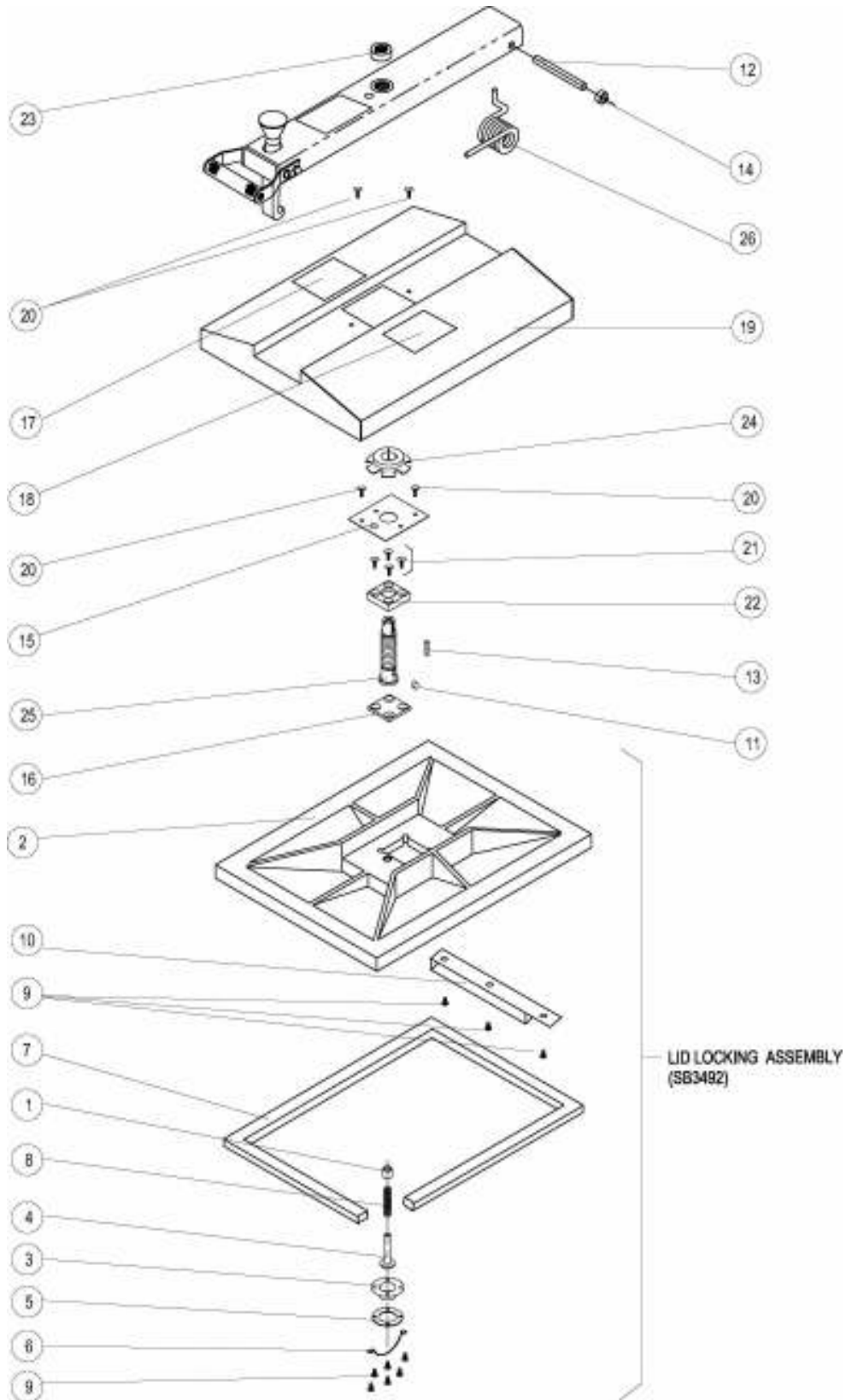

Table 3. Lid/Arm Assembly (AN3211350S) Parts

ITEM #	PART #	QTY	DESCRIPTION
Figure 3 (sheet 1)	AN3211350S		LID/ARM ASSY
Figure 3 (sheet 2)	H0157	1	HANDLE, SPIN FOR FRYERS
1	FT0332	3	STUD, 5.5" TIGHTEN DN HN
2	K0003	2	KNOB, BLACK #85C
3	K0020	1	HUB, TIGHTEN DOWN
4	K0043	1	KNOB, ORANGE
Figure 3 (sheet 3)	AB19103900	1	ARM ASSY, LGF
1	A0120	1	ARM COMPLETE FKM LGF
2	H0155	1	HANDLE, BLK DELRIN FKM LPF LGF
3	P0094	1	PIN, HOOK FKM, LPF, LGF
4	H0024	1	HOOK, LID 1018 ALLOY
5	K0043	1	KNOB, ORANGE
6	N0160	1	DECAL, WARNING BEFORE USING
7	NUT128	2	NUT, 5/16-18 SS 18-8 CAP
8	S0091	1	SPRING, HOOK LGF LPF FKM
9	SCR122	2	SCREW, 1/4-20 X 1/2 FLAT HD
10	SCR259	2	SCREW, 1/4-20 X 1/2 PHIL RD HD
11	TB0020	1	BUSHING, BRONZE 1"
12	H0156	2	HANDLE SIDE FOR H0155 FKM LPF LGF
13	WSH045	2	WASHER, 5/16 LOCK ZINC PLTD
14	WSH102	2	WASHER, 1/4 INT LOCK
15	FT0407	1	PLUG, HOLE 3/8" SHORT PRONG
16	F0026	1	ROLL PIN, 5/32 X 3/4
Figure 3 (sheet 4)	SB3492	1	LID LOCKING ASSY, LGF DOVE TAIL
1	B0857*	1	BUSHING, BRONZE 3/8X9/16X5/8
2	C0464*	1	CASTING, LGF TOP W/DOVETAIL ALAMAG35
3	D0054	1	DIAPHRAGM, LGF
4	F0286	1	PIN, LOCKING .810 X 2.25
5	FKMA199	1	RETAINER, DIAPHRAGM FKM
6	G0033	1	GUARD, DIAPHRAGM
7	G0093*	1	GASKET, SQ SILICONE BONDED LGF
8	S0045	1	SPRING, LOCKING PIN 1.85 OAL
9	SCR176	9	SCREW, 8-32 X 3/8 SLOT BINDING
10	WLGFA107	1	CONDENSATE DRAIN WELDMENT
11	F0107	1	LOCK KEY PIN, FRYERS
12	FKMA016	1	PIN, HINGE
13	FKMA152	1	KEY, TIGHTEN DOWN SCREW
14	FT0049	2	COLLAR, 1/2" SET BRIGHT
15	LGFA134*	1	TIGHTEN DOWN PLATE, LGF
16	LZ0107	1	PLATE, LID FOR LOCKING DEVICE
17	N0153	1	DECAL, FKM WARNING ACME SCREW
18	N0345	1	DECAL, HOOK LID INSTRUCTIONS
19	SB3264	1	CAST LID COVER WELD. LGF
20	SCR151	4	SCREW, 10-32 X 3/4 SOC HD CAP
21	SCR178	1	SCREW, 5/16-18 X 1 FLAT HD
22	TB0021*	1	TIGHTEN DOWN BASE COLD ROLLED
23	TC0003	1	COLLAR, THREADED SHAFT
24	TC0005*	1	COLLAR, LOCKING RING
25	TS0010*	1	SCREW, TIGHTEN DOWN
26	S0071	1	SPRING, TORSION

* - Part of Cast Lid Assembly SB3491S.

Figure 4. Dead Weight & Pressure Gauge Assembly

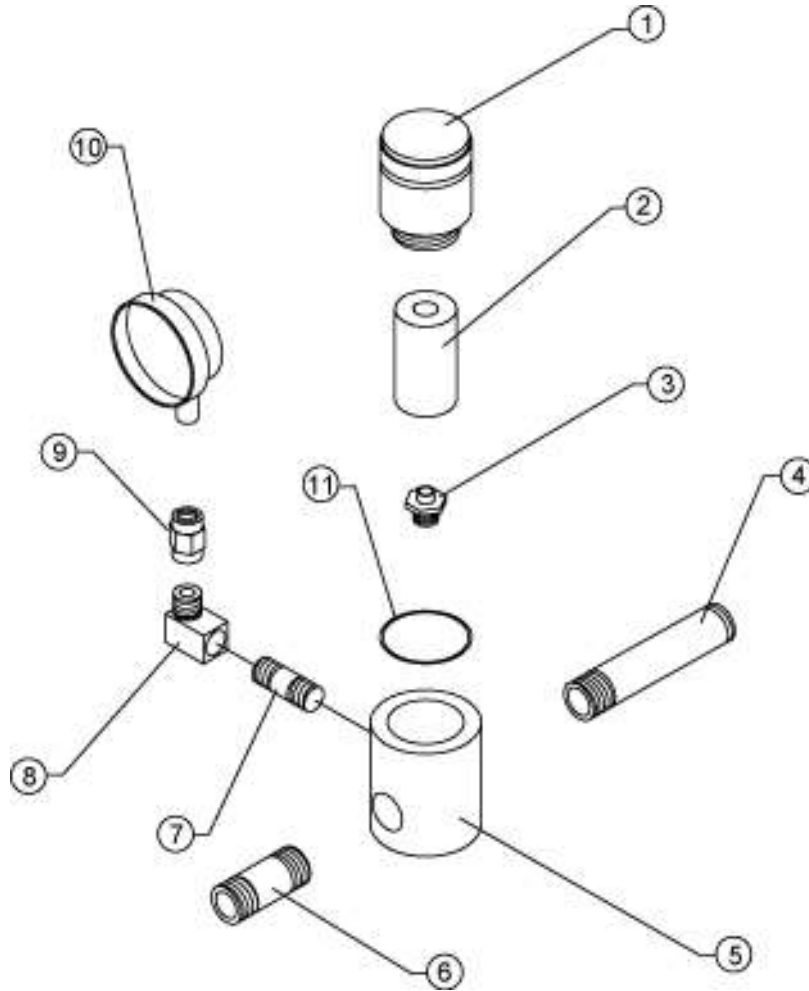

Table 4. Dead Weight & Pressure Gauge Assembly Parts

ITEM #	PART #	QTY	DESCRIPTION
1	C0657	1	COVER, DEAD WEIGHT VALVE FKM
2	W0201	1	WEIGHT, VALVE FKM 12#
3	O0001	1	ORIFICE, SS
4	FT0414	1	NIPPLE, 1/2 X 3 3/4 SS SCH 80
5	B0965	1	BODY, DEAD WEIGHT VALVE LGF SS
6	FT0232	1	NIPPLE, 1/2 X 2 SS 304
7	FT0234	1	NIPPLE, 1/4 X 1 1/2 SS 304
8	FT0190	1	ELL, STREET 1/4 90 DEG CP
9	FT0084	1	COUPLING, BRASS 1/4
10	G0064	1	GAUGE, PRESSURE 30 PSI
11	O0002	1	GASKET, O-RING #2-222

Figure 5. Drain/Motor/Piping Assembly

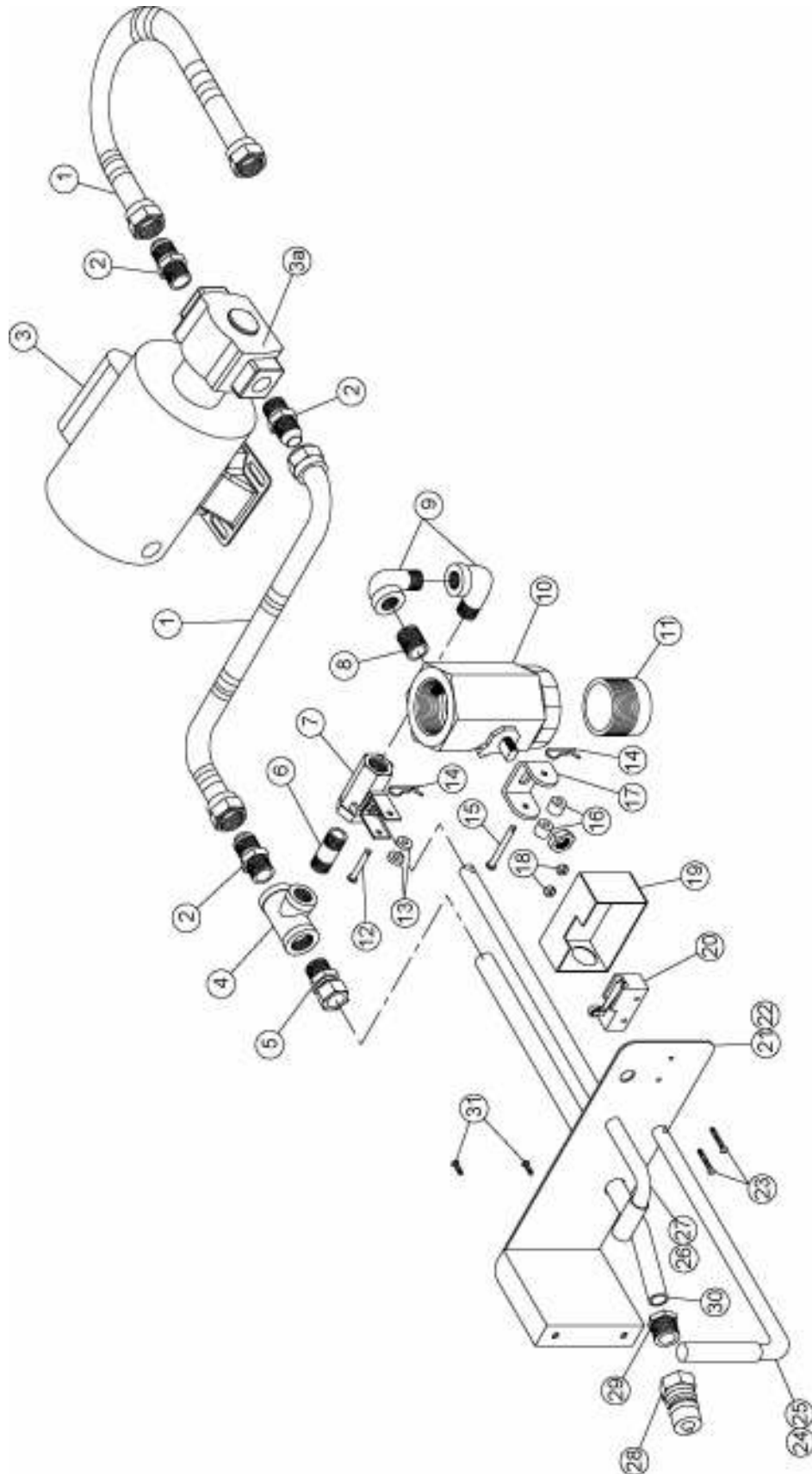

Table 5. Drain/Motor/Piping Assembly Parts

ITEM #	PART #	QTY	DESCRIPTION
1	TU0205	2	TUBING, 12" 1/2" ID
2	FT0536	3	COUPLING, 5/8 45° FLARE TO
3	M0053	1	MOTOR, LEESON LESS CORD/PUMP
3a	P0070	1	PUMP ONLY FOR HAIGHT MOTOR
4	FT0538	1	TEE, 1/2 X 1/2 X 3/8 BLK
5	FT0507	1	CONNECTOR, MALE 10FBU-S NKL PLTD
6	FT0412	1	NIPPLE, 3/8 NPT X 1 1/2 SCH 40
7	SB1314	1	BALL VALVE ASSY, FRYERS
8	FT0051	1	NIPPLE, 3/8 X C BLK
9	FT0044	2	ELL, STREET 3/8 90 DEG BLACK
10	MB19101000	1	DRAIN VALVE
11	LGFA322	1	DRAIN VALVE EXTENSION
12	F0255	1	PIN, CLEVIS 3/16 X 1-1/4
13	SP0014	2	SPACER, ALUM 0.50 X 0.125
14	F0254	2	PIN, COTTER HAIRPIN #213
15	F0253	1	PIN, CLEVIS 3/16 X 1-3/4
16	SP0034	2	SPACER, DRAIN VALVE BRKT
17	FT0543	1	DRAIN VALVE BRACKET, FRYERS
18	NUT253	2	NUT, 6-32 S/S 18-8 NYLON
19	LGFA240	1	COVER, MICROSWITCH
20	S0054	1	SWITCH, MICRO BZ-2RW822-A2
21	WLGFA348	1	HANDLE PLATE WELD
22	N0270	1	DECAL, DRAIN SUPPORT PLATE LGF
23	SCR326	2	SCREW, 6-32 X 1-3/4 SLTD RD HD
24	H0216	1	HANDLE, DRAIN VALVE
25	C0672	1	COVER, DRAIN HANDLE RED
26	LGFA192	1	HANDLE, FILL VALVE
27	C0668	1	COVER, FILL HANDLE BLACK
28	P0081	1	PLUG, F-H4F4-7-7 QUIK DISCONN
29	B0851	1	BUSHING, BLK HEX REDUCING
30	LGFA212	1	TUBING, TEE TO DISCONNECT
31	SCR016	2	SCREW, 10 X 1/2 SLTD HEX WSHR

Figure 6. Burner Tray Assembly

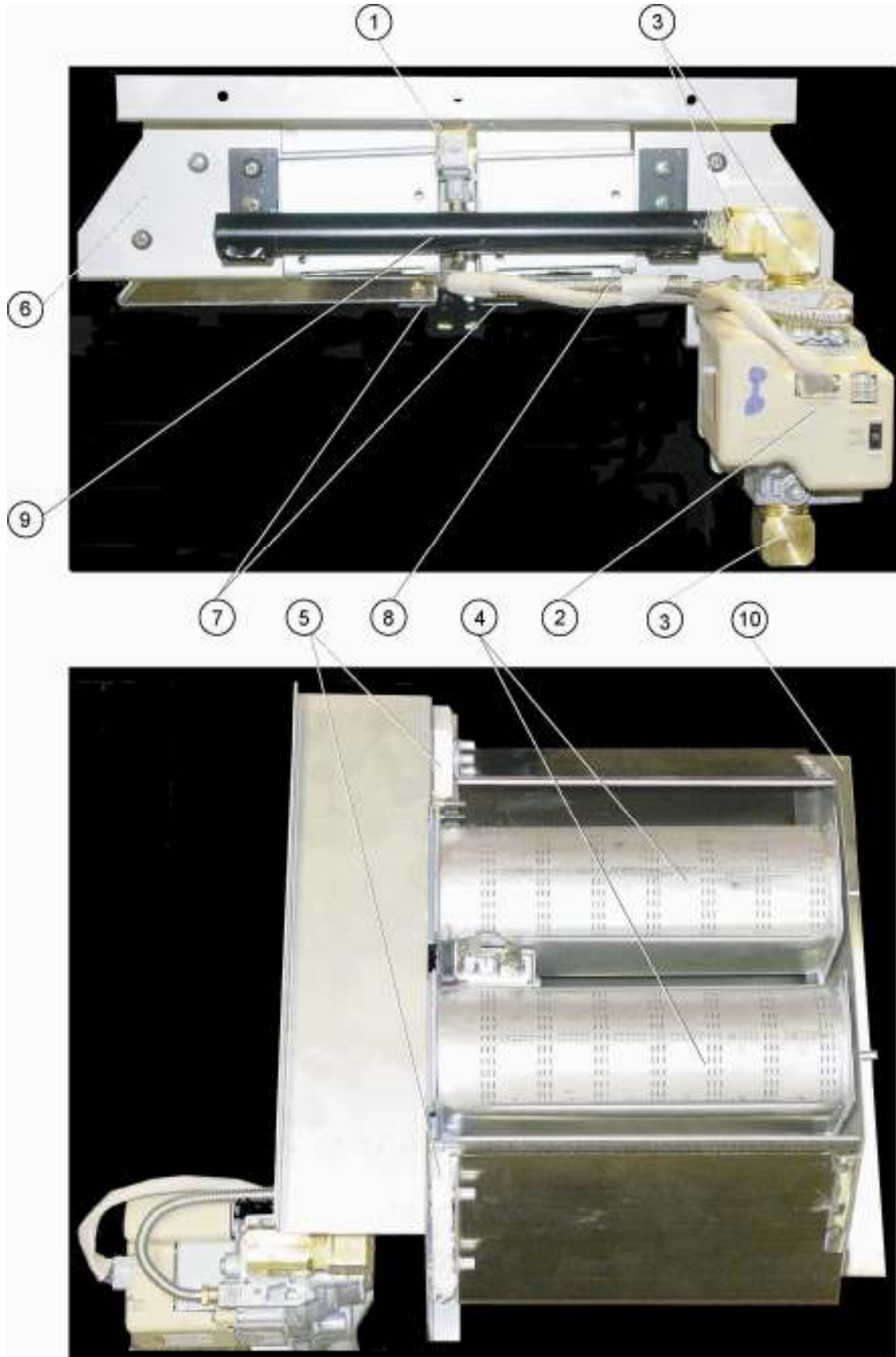

Table 6. Burner Tray Assembly Parts

ITEM #	PART #	QTY	DESCRIPTION
	SB3467	1	LP GAS BURNER TRAY ASSEMBLY
1	C0724	1	GAS CONTROL PILOT BURNER
	O0011	1	ORIFICE, ASSY BBR12 (LGF)
2	C0727	1	GAS CONTROL, STEP OPEN LP
3	FT0399	3	ELL, STREET 1/2" 90 BRASS
4	GB0004	2	BURNER, GAS BRAY LGF
5	I0015	0.083	INSULATION, BOARD 7/16
6	LGFA233	1	BURNER TRAY FRONT W/SLOT
7	LGFA323	1	PILOT BRKT, HOT SURFACE IGNITION
8	ML0064	1	S/S TUBING 304 1/4 DIA CORRUG.18"
9	SB3346	1	MANIFOLD ASSY, LGF LP NO DWG
	LGFA052	2	BURNER ORIFICE, LP O0005
	MN0001	1	MANIFOLD, GAS SUPPLY
10	SB3468	1	BURNER TRAY, REAR WELD LGF
	SB3466	1	NATURAL GAS BURNER TRAY ASSEMBLY
1	C0724	1	GAS CONTROL PILOT BURNER
	O0023	5	ORIFICE, PILOT BURNER NAT (LGF)
2	C0726	1	GAS CONTROL, STEP OPEN NATURAL
3	FT0399	3	ELL, STREET 1/2" 90 BRASS
4	GB0004	2	BURNER, GAS BRAY LGF
5	I0015	0.083	INSULATION, BOARD 7/16
6	LGFA233	1	BURNER TRAY FRONT W/SLOT
7	LGFA323	1	PILOT BRKT, HOT SURFACE IGNITION
8	ML0064	1	S/S TUBING 304 1/4 DIA CORRUG.18"
9	SB3330	1	MANIFOLD ASSY, LGF NAT
	LGFA053	2	BURNER ORIFICE, NATURAL O0005
	MN0001	1	MANIFOLD, GAS SUPPLY
10	SB3468	1	BURNER TRAY, REAR WELD LGF

Figure 7. Control/Insulation Panel LGF & LGF-F

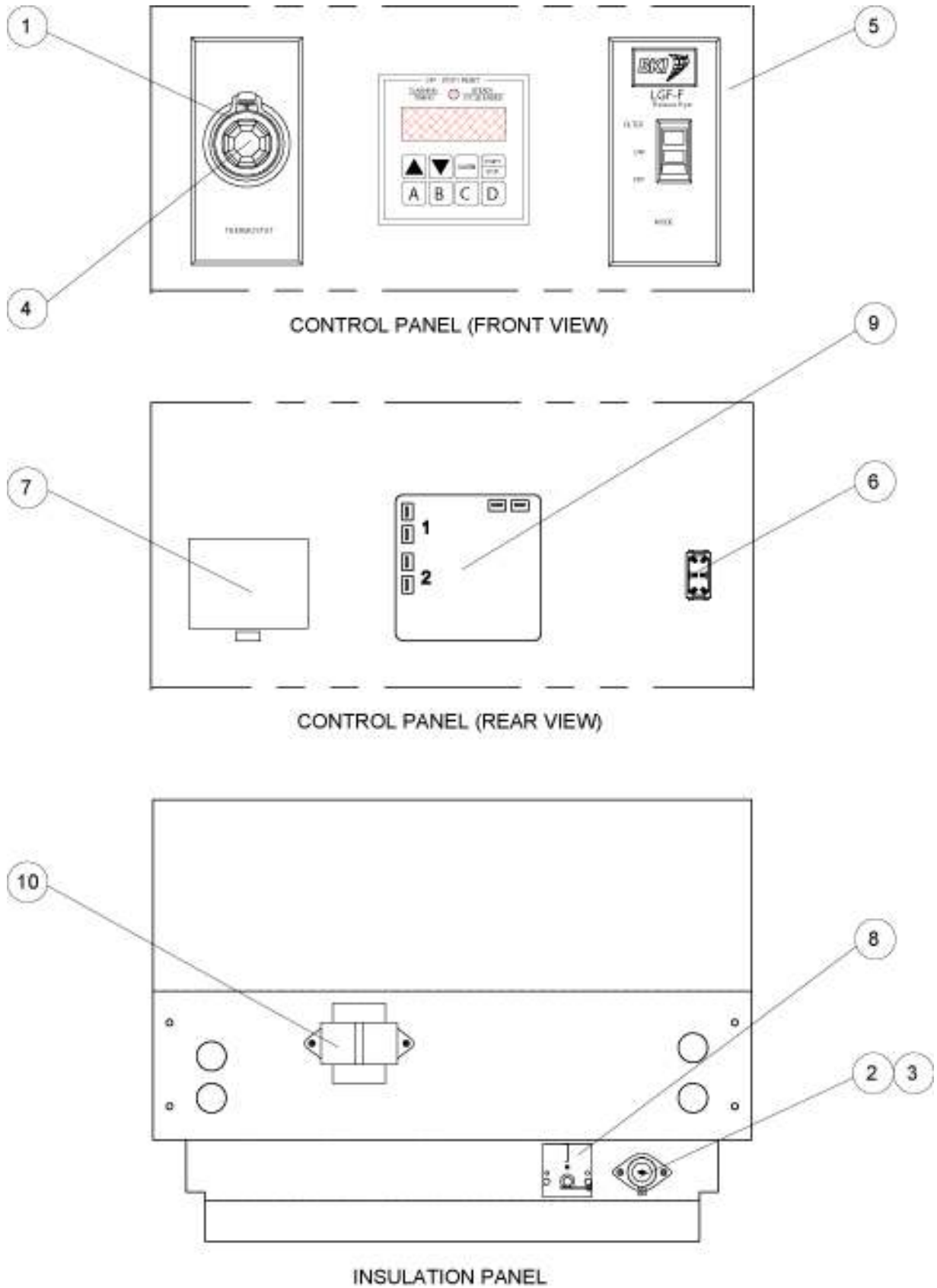

Table 7. Control/Insulation Panel LGF & LGF-F Parts

ITEM #	PART #	QTY	DESCRIPTION
1	B1050	1	BEZEL, ROBERTSHAW THERMOSTAT
2	F0097	1	FUSE, 15A 300V SC15 TIME DELAY
3	FH0001	1	FUSE HOLDER, 15A 300V HPF-EE
4	K0030	1	KNOB, T-STAT BLK 400DEG
5	N0267	1	DECAL, CONTROL PANEL LGF
6	S0104	2	SWITCH, RKR DPDT 15A 250V LAMP
7	T0022	1	THERMOSTAT, 375 DEG SGL POLE
8	T0024	1	THERMOSTAT, HI LIMIT 425 DEG
9	TI0032	1	TIMER, 230V DIGITAL 4 BUTTON
10	TF0030	1	TRANSFORMER, 240-24V LGF
	TF0005		TRANSFORMER, 120-24V LGF

Figure 8. Control/Insulation Panel LGF -FC

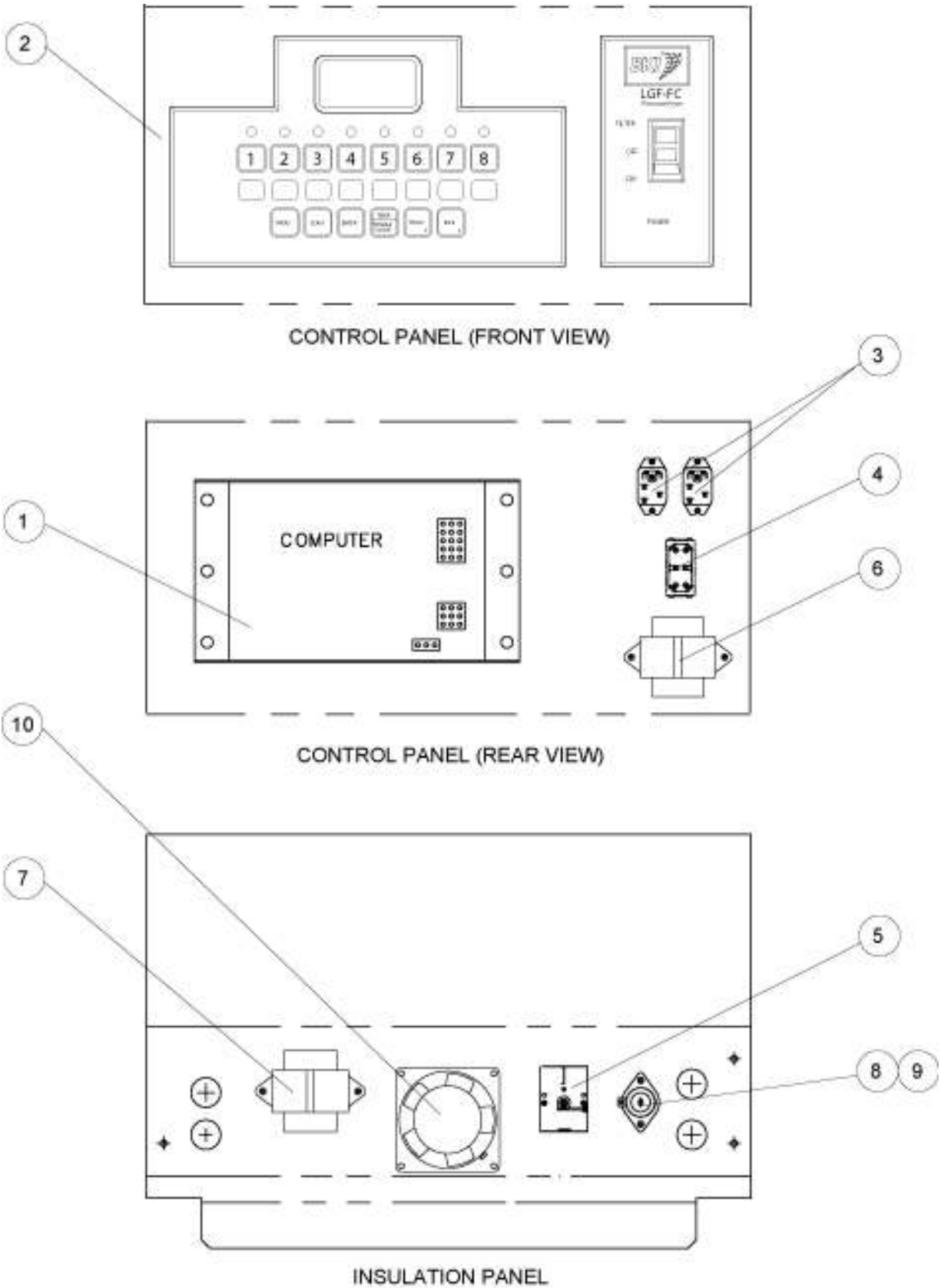

Table 8. Control/Insulation Panel LGF -FC Parts

ITEM #	PART #	QTY	DESCRIPTION
1	CP0039	1	CONTROLLER, VFD LESS HARNESS
2	N0404	1	DECAL, CONTROL LGFFC COMPUTER
3	R0044	2	RELAY, X-40, SGL FRYER
4	S0104	1	SWITCH, RKR DPDT 15A 250V LAMP
5	T0024	1	THERMOSTAT, HI LIMIT 425 DEG
6	W0053 W0054	1	TRANSFORMER ASSY, 120V TRANSFORMER ASSY 240V
7	TF0030 TF0005	1	TRANSFORMER, 240-24V LGF TRANSFORMER, 120-24V LGF
8	F0097	1	FUSE, 15A 300V SC15 TIME DELAY
9	FH0001	1	FUSE HOLDER, 15A 300V HPF-EE
10	FN0013 FN0014	1	FAN, 115V NMB 3115FS12WB30 FAN, 230V NMB 3115FS23WB30

Figure 9. Door Assembly W/Pocket (SB3290)

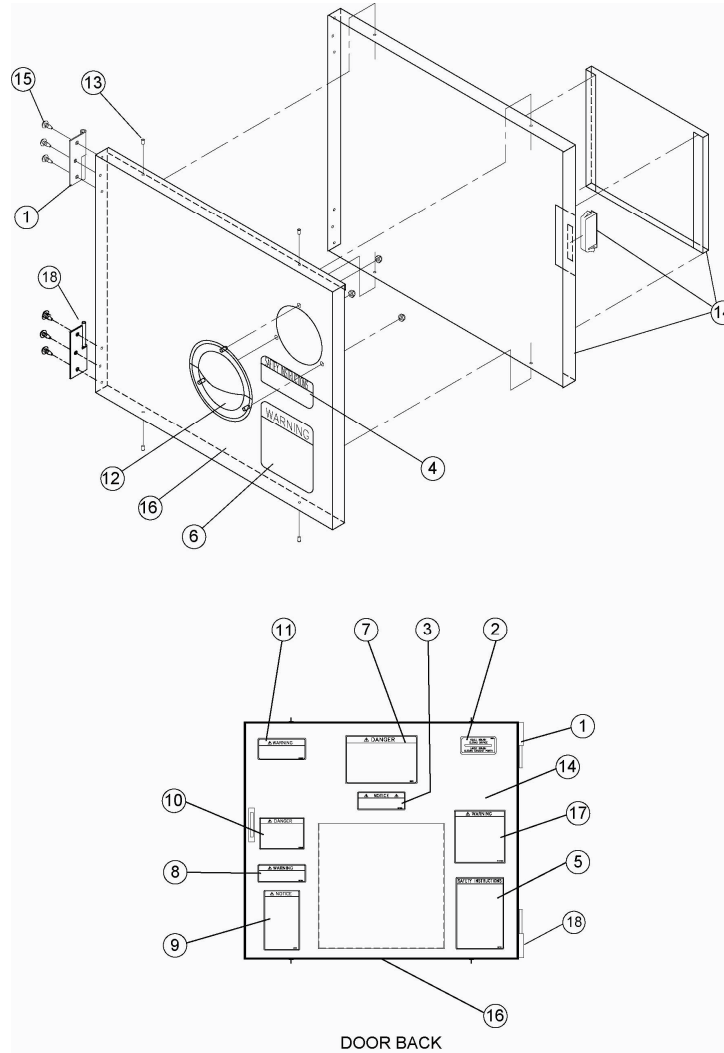

Table 9. Door Assembly W/Pocket (SB3290) Parts

ITEM #	PART #	QTY	DESCRIPTION
1	H0010	2	HINGE, DOOR, LH, PIN SIDE FRY.DOORS
2	N0059	1	DECAL, SMALL BRUSH/
3	N0165	1	DECAL, NOTICE LOST MANUAL
4	N0169	1	DECAL, MANUAL GAS SHUT OFF
5	N0527	1	DECAL, SAFETY INSTR FRYERS
6	N0175	1	DECAL, SLIPPING ADMONITIONS
7	N0176	1	DECAL, INSTR & SAFETY MANUAL
8	N0181	1	DECAL, USE ONLY ON NON-COMBUST
9	N0319	1	DECAL, RESTRAIN DEVICE FR/CAN
10	N0346	1	DECAL, LGF RESTRAINING WARNING
11	N0350	1	DECAL, GAS WARNING LGF
12	P0022	1	HANDLE, PULL SS P60-1010
13	RIV172	4	RIVET, 1/8 X 1/4 CS PLT POP
14	SB3289	1	LGF INSIDE DOOR WELDMENT
15	SCR008	6	SCREW, 10 X 1/2 PHIL TRUSS HD
16	WLPFA096	1	DOOR, LPF CORNERS WELDED
17	N0153	1	DECAL, FKM WARNING ACME SCREW
18	H0009	1	HINGE, DOOR, RH, PIN SIDE FRY.DOORS

Figure 10. Oil Vat Assembly (AN32112800)

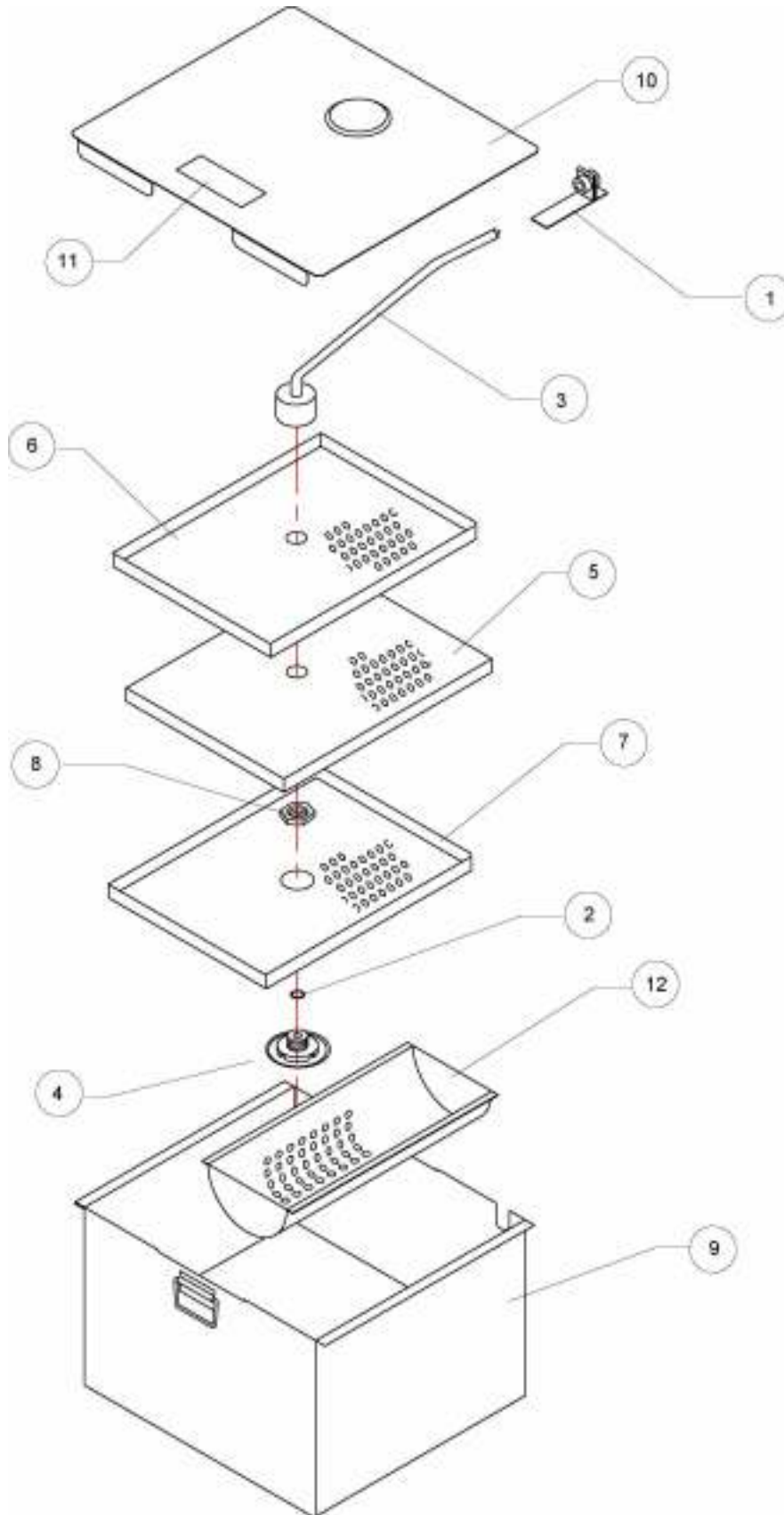

Table 10. Oil Vat Assembly (AN32112800) Parts

ITEM #	PART #	QTY	DESCRIPTION
	AN86208400	1	FILTER SCREEN ASSY, LGF
1	SB1991	1	QUIK DISCONNECT BRACKET WELDMENT
2	O0013	1	O-RING, FLUOROCARBON V680-70
3	WB86202700	1	FILTER TUBING/DISCONN ALF LGF LPF
4	SB7659	1	FILTER SCREEN FITTING SPOTWELD
5	FS0003	1	FILTER SCREEN, TOP
6	FS0002	1	FILTER SCREEN, INTERCEPTOR
7	FS0001	1	FILTER SCREEN, BOTTOM
8	FC0004	1	NUT SCREEN RETAINING FKM-F &
9	WB32112600	1	FILTER VAT WELD ALF LPF LGF
10	FB32112702	1	COVER, FILTER VAT LGF
11	N0395	1	DECAL, VAT COVER SAFETY WARN
12	SB2306	1	S/S CRUMB BASKET WELD, FKF

Figure 11. Outlet Box Assembly

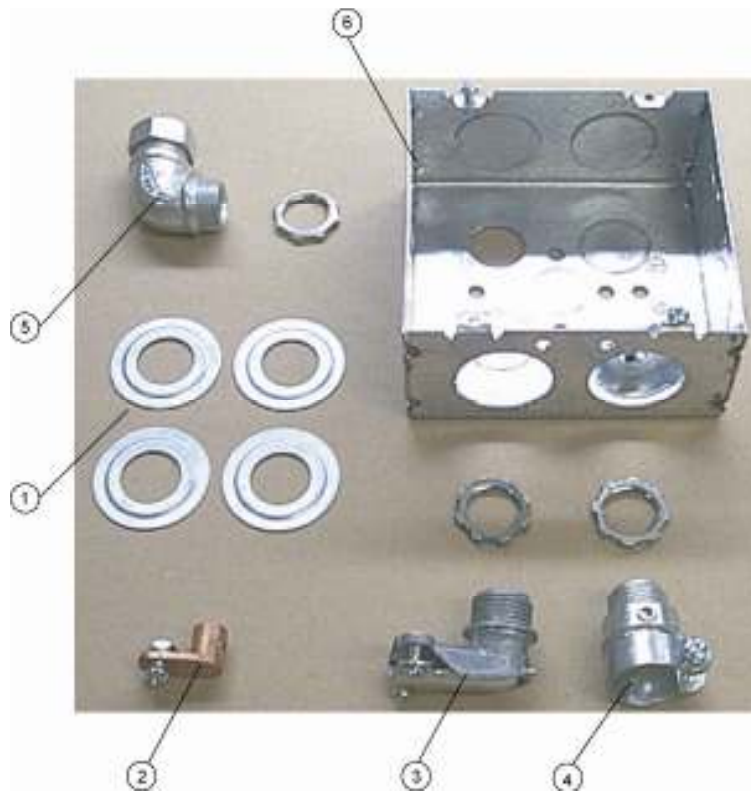

Table 11. Outlet Box Assembly Parts

ITEM #	PART #	QTY	DESCRIPTION
1	F0067	4	WASHER, REDUCER #100-50
2	F0111	1	TERMINAL GROUNDING LUG
3	FT0153	1	CONNECTOR, BOX 3/8 X 90
4	FT0206	1	CONNECTOR, 1/2" 1002DC
5	FT0359	1	ELL, 1/2 90 SHORT
6	OB0004	1	BOX, OUTLET 4 11/16 SQ
7	C0652	1	COVER, #72C-1 FOR OB0004 (not shown)

Figure 12. Solenoid Valve Assembly

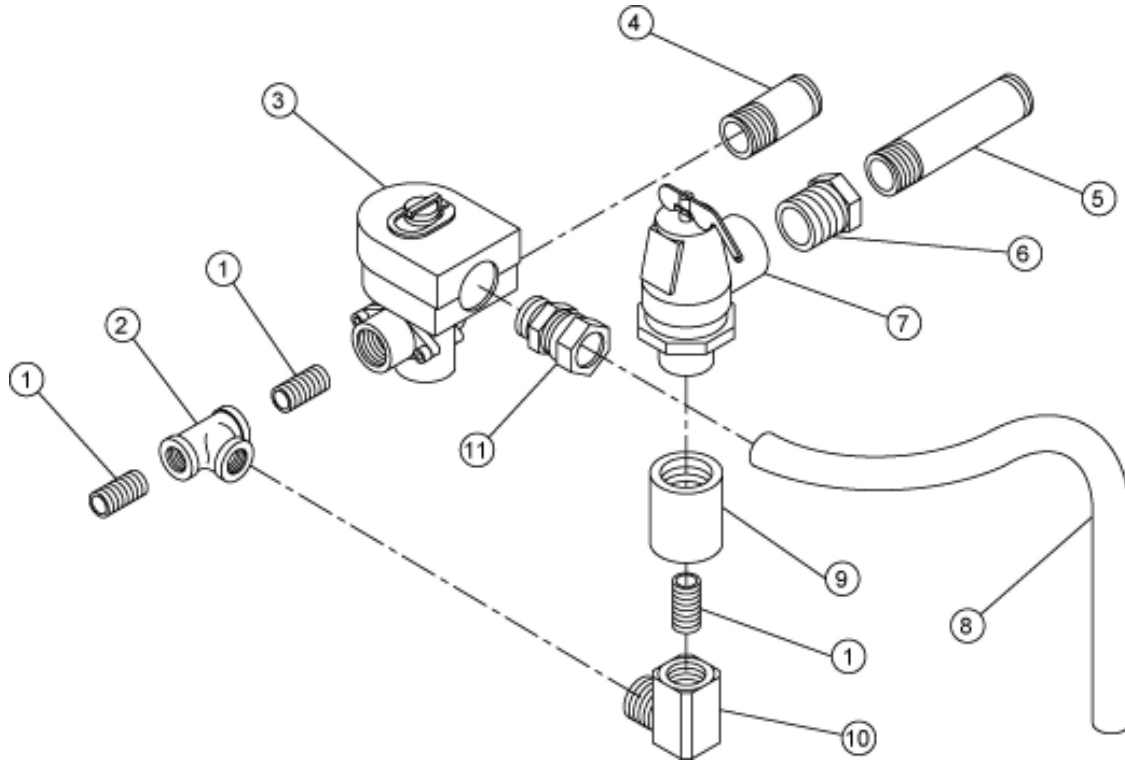

Table 12. Solenoid Valve Assembly Parts

ITEM #	PART #	QTY	DESCRIPTION
1	FT0235	3	NIPPLE, 1/2 X C SS
2	FT0198	1	TEE, BRASS 1/2" CP
3	SV0004	1	VALVE, SOLENOID HV-214-761-2 120V
4	FT0413	1	NIPPLE, 1/2 X 1 3/4 SS
5	FT0414	1	NIPPLE, 1/2 X 3 3/4 SS
6	FT0067	1	BUSHING, C110JO 3/4 X 1/2 CP
7	PV0001	1	VALVE, POP SAFETY
8	LGFA228	1	CONDUIT 1/2" EMT 20.062"
9	FT0398	1	REDUCING COUPLING
10	FT0404	1	ELL, 1/2" STREET CHROME PLTD
11	FT0358	1	CONNECTOR COMPRESSION 1/2"

Figure 13. Quick Disconnect Assembly (SB1997S)

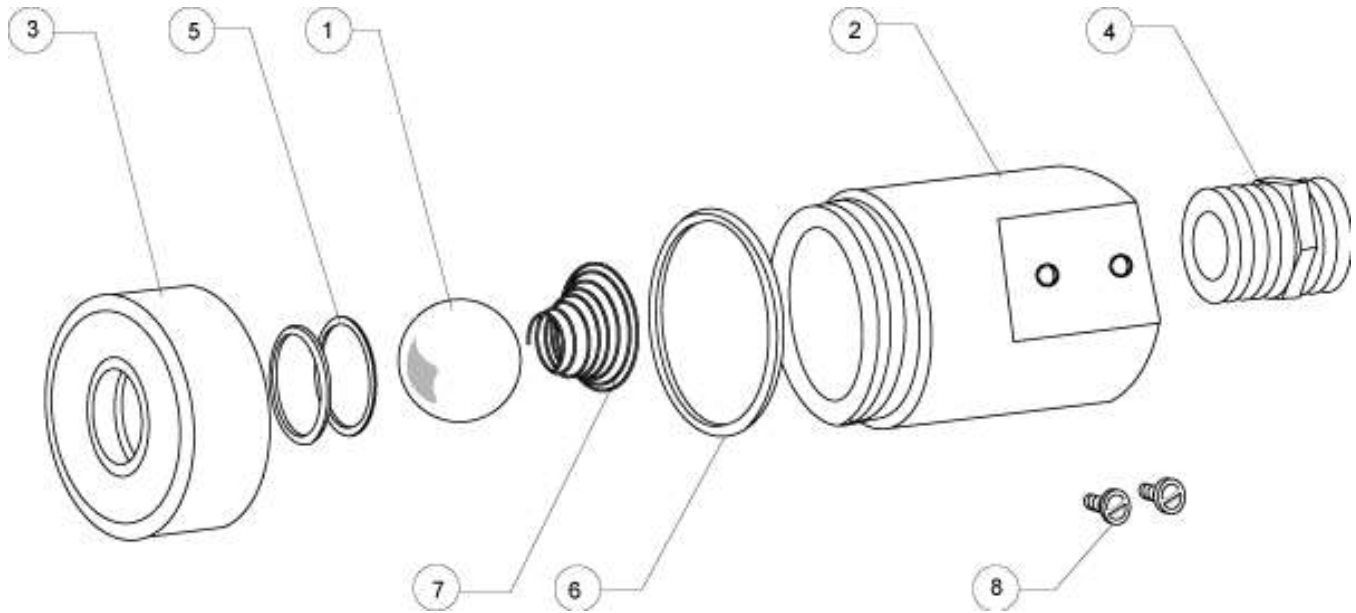

Table 13. Quick Disconnect Assembly (SB1997S) Parts

ITEM #	PART #	QTY	DESCRIPTION
1	B0996	1	BALL, 11/16" STEEL BEARING
2	FT0429	1	QUICK DISCONNECT, PUMP SIDE
3	FT0500	1	QUICK DISCONNECT, VAT SIDE
4	FT0536*	1	COUPLING, 5/8 45° FLARE TO
5	O0013	2	O-RING, FLUOROCARBON V680-70
6	O0014	1	O-RING, PARKER #2-124 LARGE
7	S0138	1	SPRING, FOR QUICK DISCONNECT
8	SCR4531*	2	SCREW, #10 24X3/8" WASHERED

* - Not included with SB1997S

Figure 14. Drain Valve & Plugs (SB1999S)

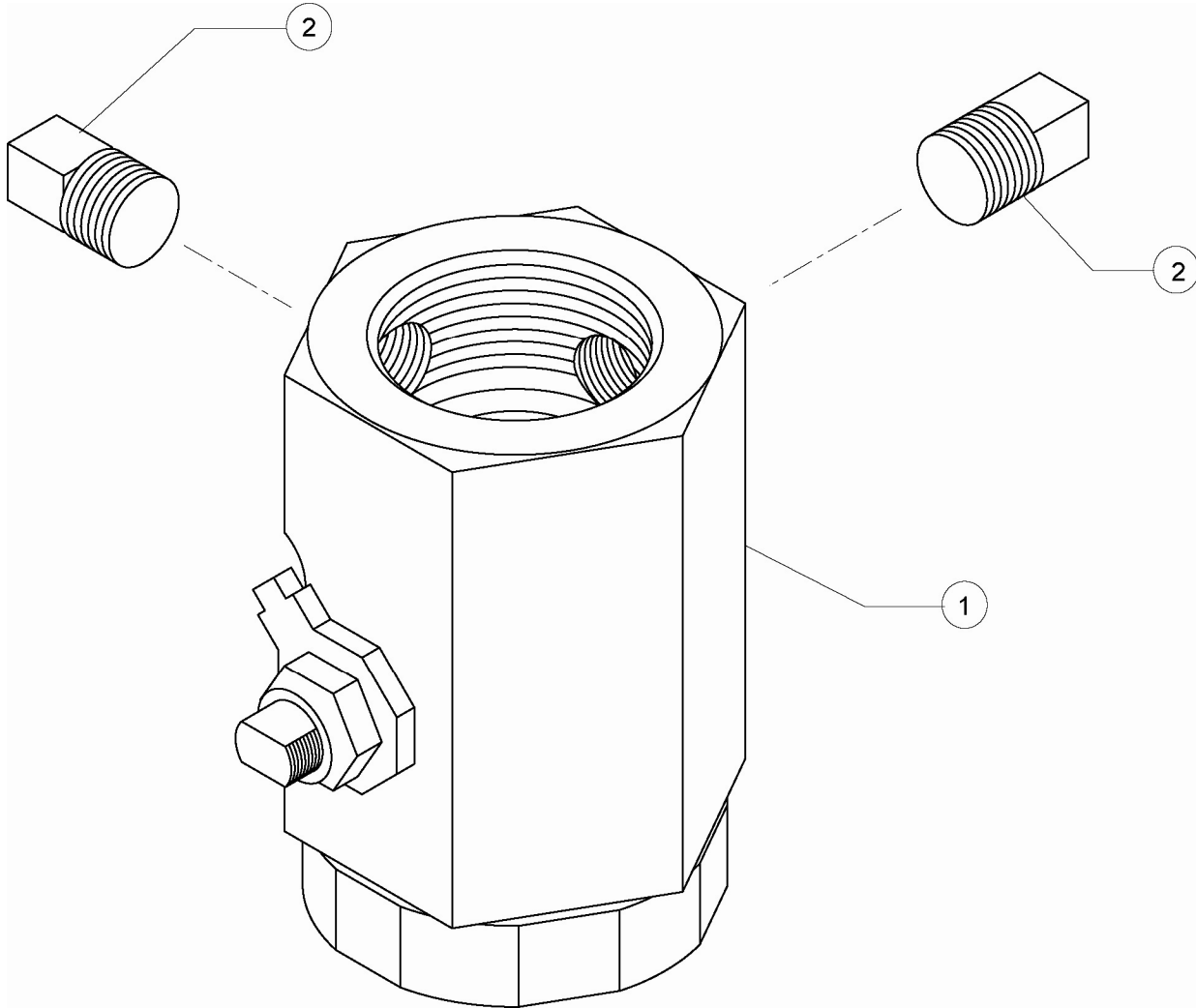

Table 14. Drain Valve & Plugs (SB1999S) Parts

ITEM #	PART #	QTY	DESCRIPTION
1	MB19101000	1	DRAIN VALVE REPLACEMENT
2	FT0243	2	PLUG, 3/8" SQ HEAD PIPE

Accessories

Description	Accessory #	Figure #	Item #
BASKET, LGF	B0108B	Figure 15	1
HANDLE, TEE STYLE LIFT	H0151	Figure 15	2
BRUSH, DRAIN (LONG WHITE)	B0075	Figure 15	3
BRUSH, LONG #5702	B0051	Figure 15	4
BRUSH, POT SCRUBBER, WHITE	B0049	Figure 15	5
BRUSH, SHORT #6175	B0052	Figure 15	6
RESTRAINT	FT0279	Figure 15	7
HOSE 72" GAS	H0048	Figure 15	8
INSULATED MITT 13"	G0052	Figure 15	9

Figure 15. Accessories



1



2



3



4



5



6



7



8



9

Components

Description	Component #	Figure #	Item #
ARM ADJUSTABLE STOP /FKM	A0101	Figure 16	1
CASTER, 2470-DIK-075-R05/22	C0409	Figure 16	2
CASTER, 2477-DIK-075-R05/22	C0410	Figure 16	3
FILTER BAG CLIP FI0007	ST0015	Figure 16	4
FILTER, FKM-F 13.5 X 20.5	FI0007	Figure 16	5
THERMISTER PROBE, 6.85 X 1	T0047	Figure 16	6

Figure 16. Components



1



2



3



4



5



6

Wiring Diagrams

Refer to the table below to find the wiring diagram associated with your unit.

Wiring Diagram	Diagram #	Figure #	Page #
LGF-F 120V/60HZ/1 Phase	SB322901	Figure 17	53
LGF-FC 120V/60HZ/1 Phase	LGFE1034	Figure 18	54
LGF-FC 220V/50HZ/1 Phase	LGFE1038	Figure 19	55
LGF-FC 220V/60HZ/1 Phase	LGFE1041	Figure 20	56
LGF-FC 240V/50HZ/1 Phase	LGFE1036	Figure 21	57

Figure 17. LGF-F 120V/60HZ/1 Phase

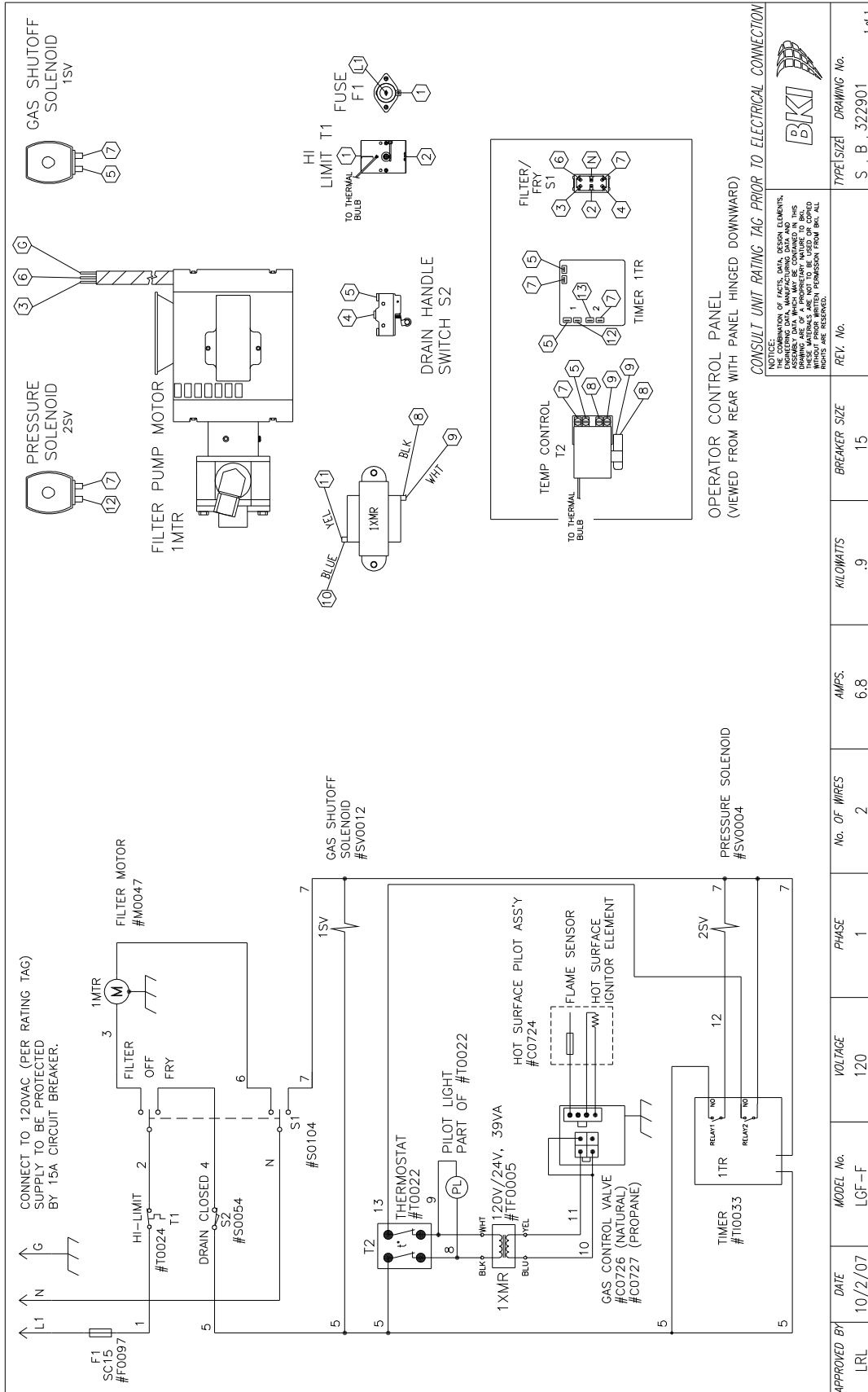

Figure 18. LGF-FC 120V/60HZ/1 Phase

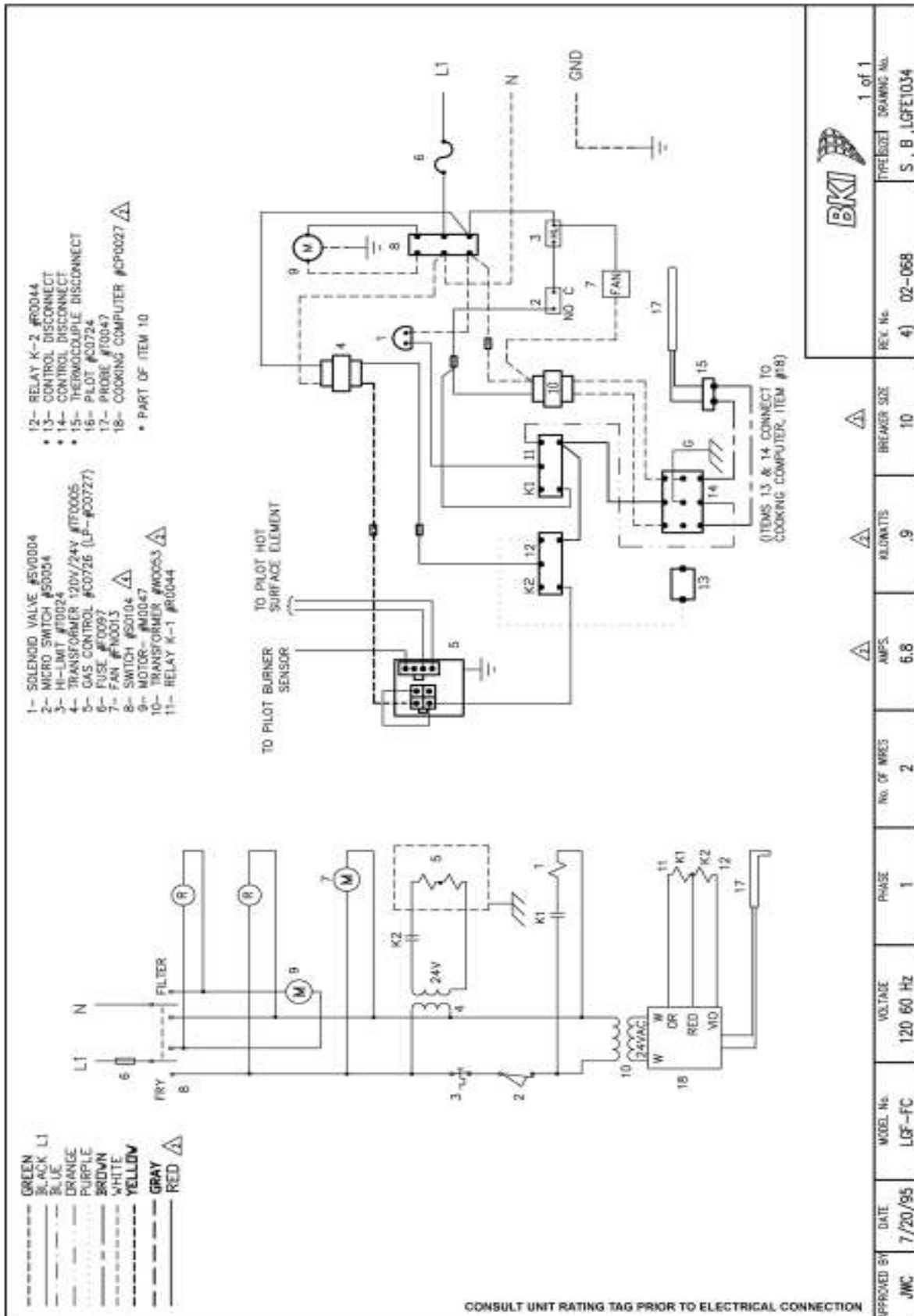
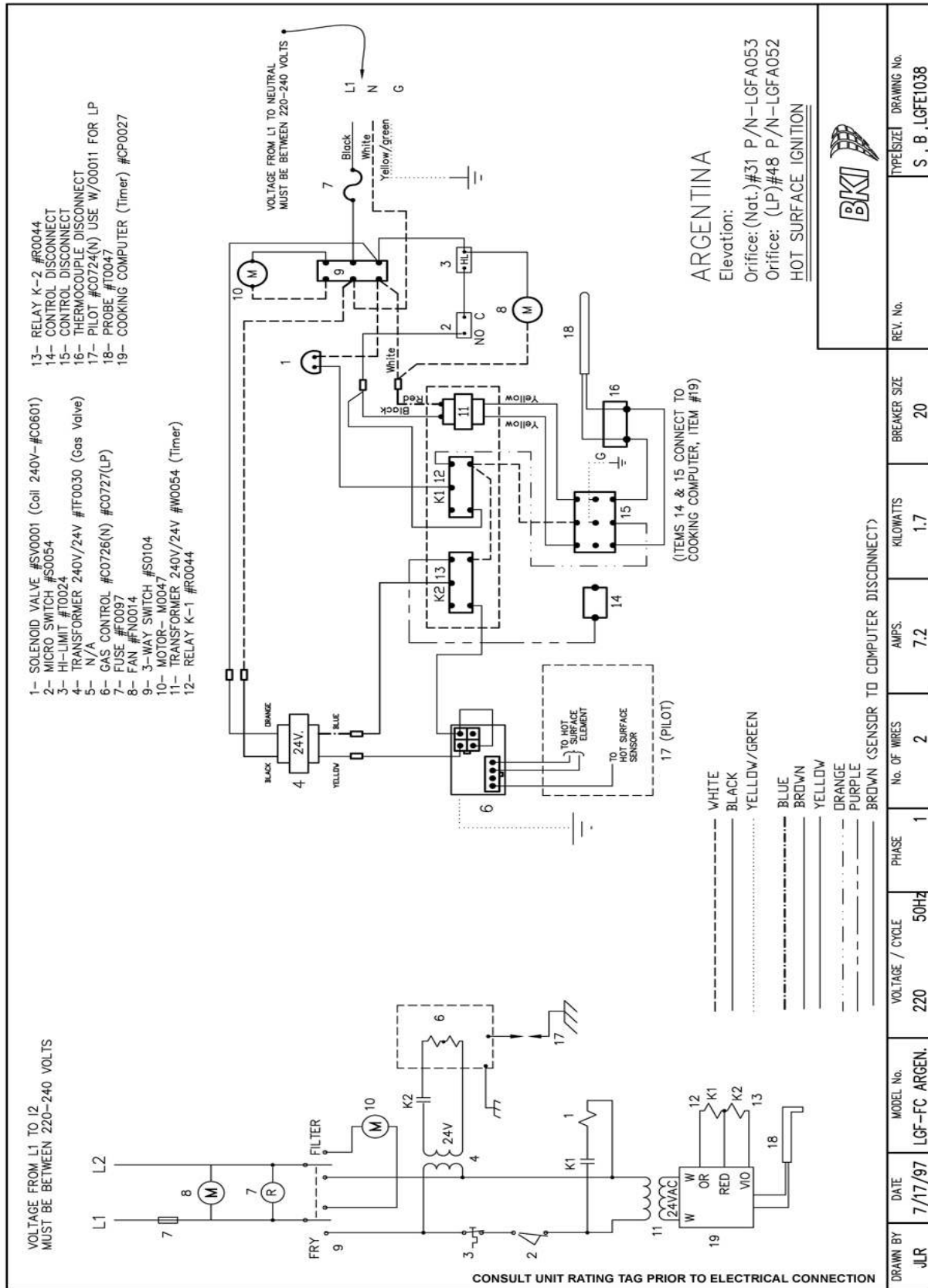

Figure 19. LGF-FC 220V/50HZ/1Ph



TYPE/SIZE	DRAWING No.
S	B_LGFE1038

DRAWN BY	DATE	MODEL No.	VOLTAGE / CYCLE	PHASE	No. OF WIRES	AMPS.	KILOWATTS	BREAKER SIZE	REV. No.
JLR	7/17/97	LGF-FC ARGEN.	220	50Hz	1	2	7.2	20	S

Figure 20. LGF-FC 220V/60HZ/1 Phase

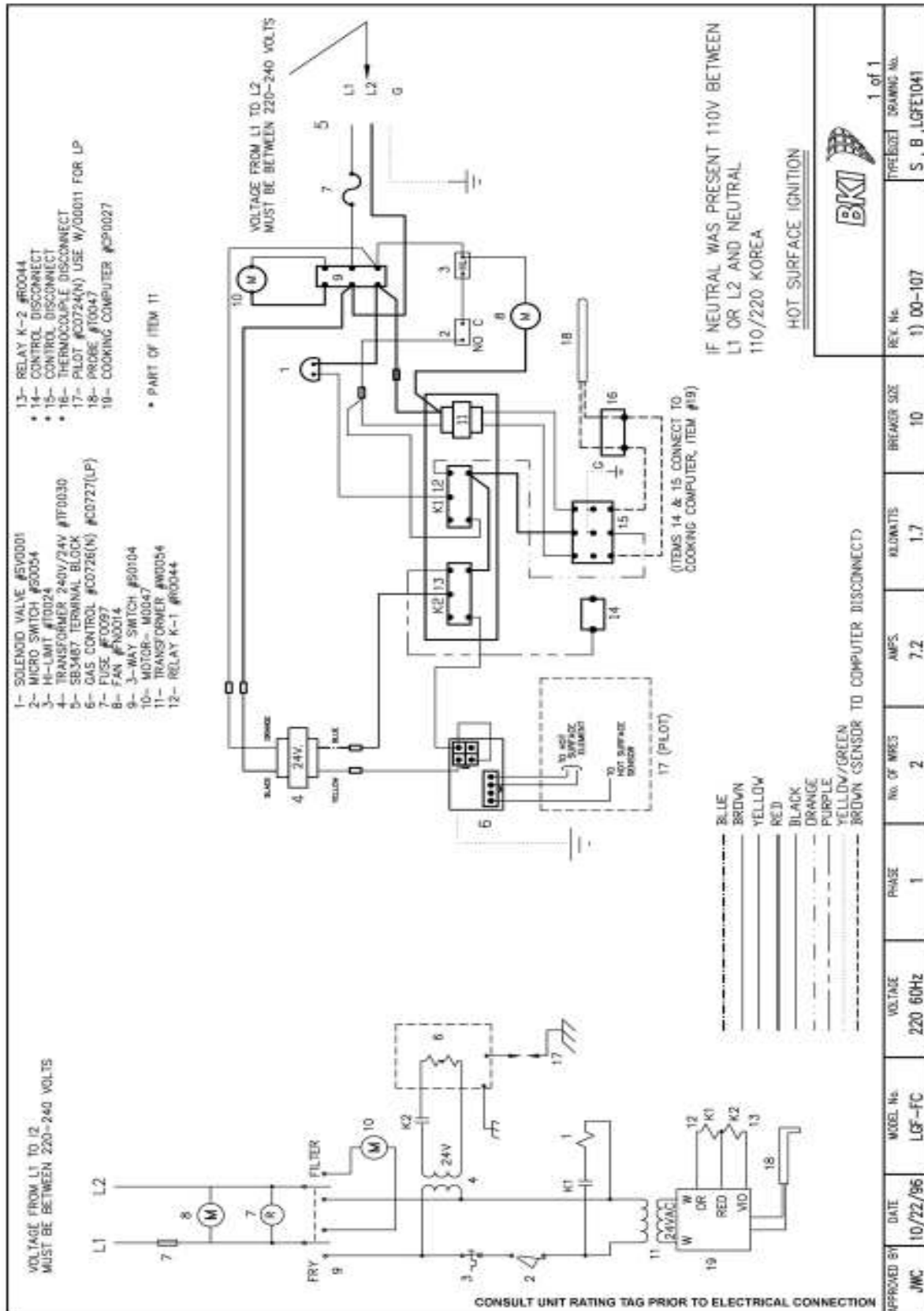
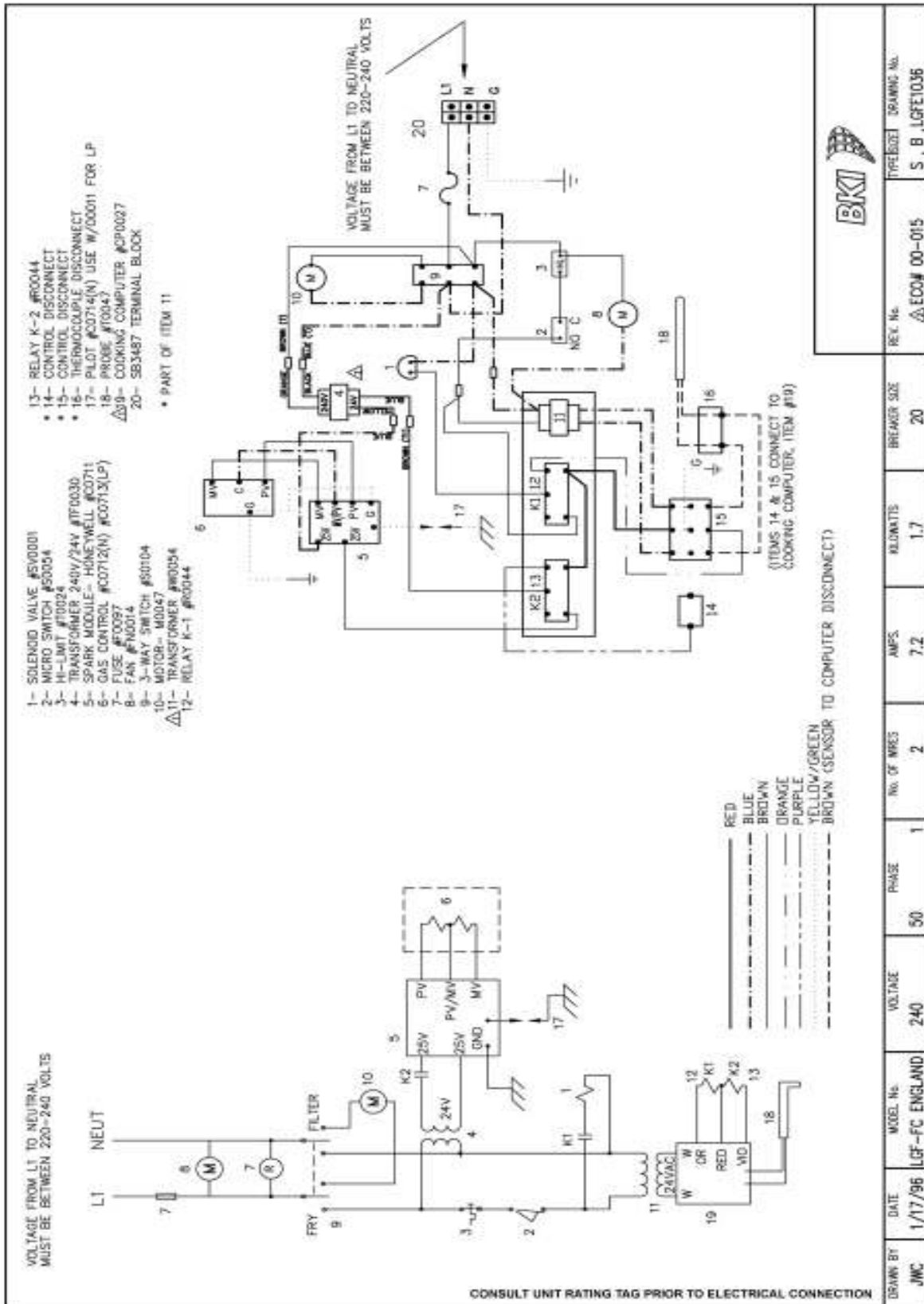

Figure 21. LGF-FC 240V/50HZ/1 Phase





2812 Grandview Dr., Simpsonville, S.C. 29680, USA
<http://www.bkideas.com>
Made and printed in the U.S.A
LI0196/0808

CS-TM-013.01

Revised 3/1/13

REVISION HISTORY

<u>REVISION</u>	<u>DATE</u>	<u>REVISED BY</u>	<u>DESCRIPTION</u>
01	03/01/13	KW	Initial Release-Supersedes all previous releases