

Intake Overview

Clean air is necessary for efficient fuel combustion and for normal engine life. If allowed to enter the engine, airborne contaminants combine with engine oil to form an abrasive compound which may drastically shorten engine life.

On All American Forward Engine, the fresh air intake is located behind the right access panel on the front of the bus. Air enters through a screened duct into the air filter, mounted to the right of the radiator, and accessible from underneath the front bumper.

On All American Rear Engine, the fresh air intake grille is located at the top rear of the right side of the bus, immediately rearward of the rearmost window. Air enters through leuvers in the body panel into a screened duct leading to the air cleaner, which is mounted in the top right of the engine compartment. An optional precleaner (Feature 40170-01) is installed on some All American Rear Engines, immediately behind fresh air intake grille.

Fresh air passes through ductwork leading to the air filter, where airborne dirt, dust and other foreign particles are trapped in the replaceable dry filter element.

Air from the air filter enters a duct leading to the intake side of the engine's turbocharger. The turbocharger contains two turbine chambers which are internally sealed from each other. Exhaust gas passes through the exhaust-side chamber, driving the turbine vanes and shaft at high RPM before passing into the exhaust system. The turbine shaft passes through the body of the turbocharger to the intake chamber, where it drives the compressor vanes, drawing intake air from the air filter, and compressing into the inlet tube of the Charge Air Cooler.

Compressing the air causes it to give off heat. The purpose of the Charge Air System is to remove this heat before the compressed air enters the engine intake manifold. The Charge Air Cooler is a radiator-like component mounted directly to the front of the engine coolant radiator. Although the two radiators are mounted as a unit, they are components of two separate circuits and do not share air or coolant. Ambient air is drawn by the radiator fan through the cooling fins of both coolers. The cooled intake air proceeds from the CAC to the intake manifold, where it enters the engine combustion chambers under compression. This increases engine performance, and reduces emissions due to more efficient burning of the diesel fuel. The Charge Air Cooler is illustrated in the Cooling System chapter.

Air Restriction Indicator

A restriction indicator is mounted in the intake tract between the air filter and the turbo. The restriction indicator is designed to provide a visual warning in the event of overly restricted air intake, as in the case of a clogged air filter element or the presence of debris. The restriction indicator may be fitted with an option to drive a dash-mounted air restriction gauge.

On All American Forward Engine, the air restriction indicator is visible inside the right front access panel, next to the fresh air inlet. On Rear Engine All Americans, the air restriction indicator is visible in the engine compartment, mounted on the side of the duct leading from the air filter housing.



Air Restriction Indicator, Forward Engine



Air Restriction Indicator, Rear Engine

At a vacuum of 25 inches H₂O, the red piston locks, indicating that the air intake tract is too restricted.

During engine operation, the indicator monitors vacuum pressure immediately downstream of the air filter. As vacuum increases, the indicator's red piston becomes visible through the clear portion of the housing indicating that air flow is being restricted by a clogged filter, debris, or other obstruction. The Air Restriction Indicator is variable until the monitored vacuum increases to a measure of 25 inches H₂O. At that measure, the red piston fills the clear portion, and locks in its position. The indicator must then be manually reset by pressing the reset button after the restrictive condition has been corrected.

CAUTION *The Air Restriction Indicator activates only when an air flow restriction has occurred. A normal reading (no red showing) must not be misunderstood as an indication that the air filter is clean, and does not preclude the need for other inspection and maintenance. For example, a leak in the intake will allow damaging debris to enter, but will not be indicated by the Air Restriction Indicator.*

Filter restriction and proper operation of the indicator may be verified by pressing the reset button on the bottom of the indicator. If restriction is occurring, the red indicator will move when the engine is under load. The indicator will lock in position if the monitored vacuum increases to 25 inches H₂O.

It is important to understand that the Air Restriction Indicator does not detect leaks, and will not properly indicate restrictions in a leaking system. Check for leaks in all inlet hoses, tubes and connections. If a leak is found, correct it immediately, using original replacement parts and torquing all clamps.

The Air Restriction Indicator can also be tested using a calibrated vacuum gauge and vacuum pump. Check the full range of the indicator, and verify that the red indicator locks into position at 25 inches H₂O. The Air Restriction Indicator is not repairable, and should be replaced if found to be operating incorrectly.

Intake System Maintenance

Although it is a simple system, diligent maintenance and inspection of the air intake tract is critical. Never run the engine with the air cleaner or its filter element removed. Use only original replacement parts to avoid poor fit and consequent air leakage.

See the Specifications and Scheduled Maintenance chapter for recommended intake system inspection intervals.

CAUTION *The intake system inspection and maintenance intervals indicated in this manual are guidelines which assume normal operating conditions. Appropriate service intervals vary according to operating conditions. In dusty or high humidity environments, more frequent service is required.*

General Inspection

Under normal operating conditions, inspect the Air Restriction Indicator daily (more frequently in dusty high humidity conditions). Inspect the air intake system every 3 months or 5000 miles. Inspect the system for:

- Air Restriction Indicator. If red indicator is visible, replace the air cleaner element, and check the system for debris and other restrictions.
- Clamps. Tighten loose clamps and check for proper fit and seal. Replace if corroded, broken or otherwise damaged.
- Ducts and piping. Inspect for wear, damage, or abrasion.
- Air cleaner element. Replace if soiled, wet, torn, or otherwise damaged. Ensure proper installation and seal.
- Mounting brackets. Check for loose or damaged mounts.
- Charged air system piping. Tighten loose clamps. Check for wear spots and holes in the piping.
- Air compressor inlet lines. Tighten. Check for wear or other damage.

Clamps should be tightened to the following specifications:

Spring-loaded clamps. *Tighten to near full spring compression.*

T-Bolt clamps. *Tighten to 50 in. lbs. (5.6 Nm).*

Worm gear clamps. *Tighten to 38–42 in. lbs. (4.2–4.7 Nm).*

Hose clamps already in service. *Tighten to 10 in. lbs. (1.1 Nm).*

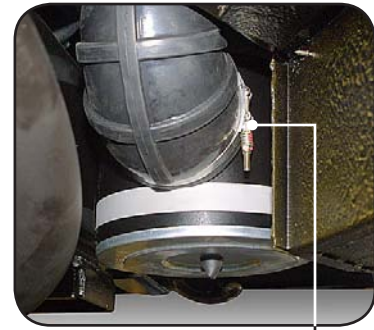

A3FE Air Filter elbow clamp

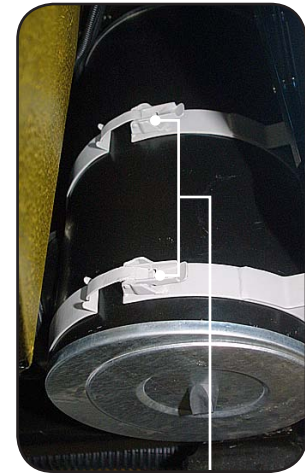

A3FE Air Filter mounting clamps

Air Filter Replacement

Replace the air filter element at least once a year, and whenever the Air Restriction Indicator has been activated (shows red). Other indicators of a dirty air cleaner element include loss of power or excessive exhaust smoke. To replace the air cleaner element:

1. Loosen the spring clamp which secures the intake elbow (FE) or intake hump hose (RE) to the air filter canister. Push the intake elbow or hump off of the filter flange.
2. Release the clasps of the two mounting clamps and remove the filter.
3. On Rear Engine All-American, remove the clamp and intake tube from the top of the filter. Clean the tube and install it on the new filter.
4. Before replacing the element, inspect all clamps, hoses, piping and seals:
 - Inspect inside the intake elbow or hump hose for signs of dust or debris finding its way into the system through leaks. Replace any damaged components allowing the leak, and clean the debris inside the elbow and ducts before installing a new element.
 - If evidence of leaks is found, check the tube between the charged air cooler and the engine intake for contamination. If contamination is found, the charged air cooler should be replaced.
5. Install a new air cleaner element, fully seating its top seal.
6. Assemble removed parts in reverse order of disassembly. Ensure that the intake elbow or hump hose is properly seated all the way around the flange of the filter. All duct connections downstream of the air filter must be air tight.

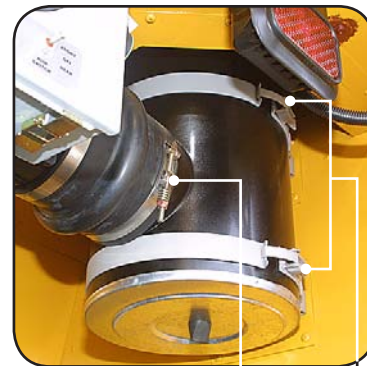

A3RE Air Filter Hump Hose clamp

A3RE Air Filter mounting clamp

Intake Tract: A3RE Precleaner

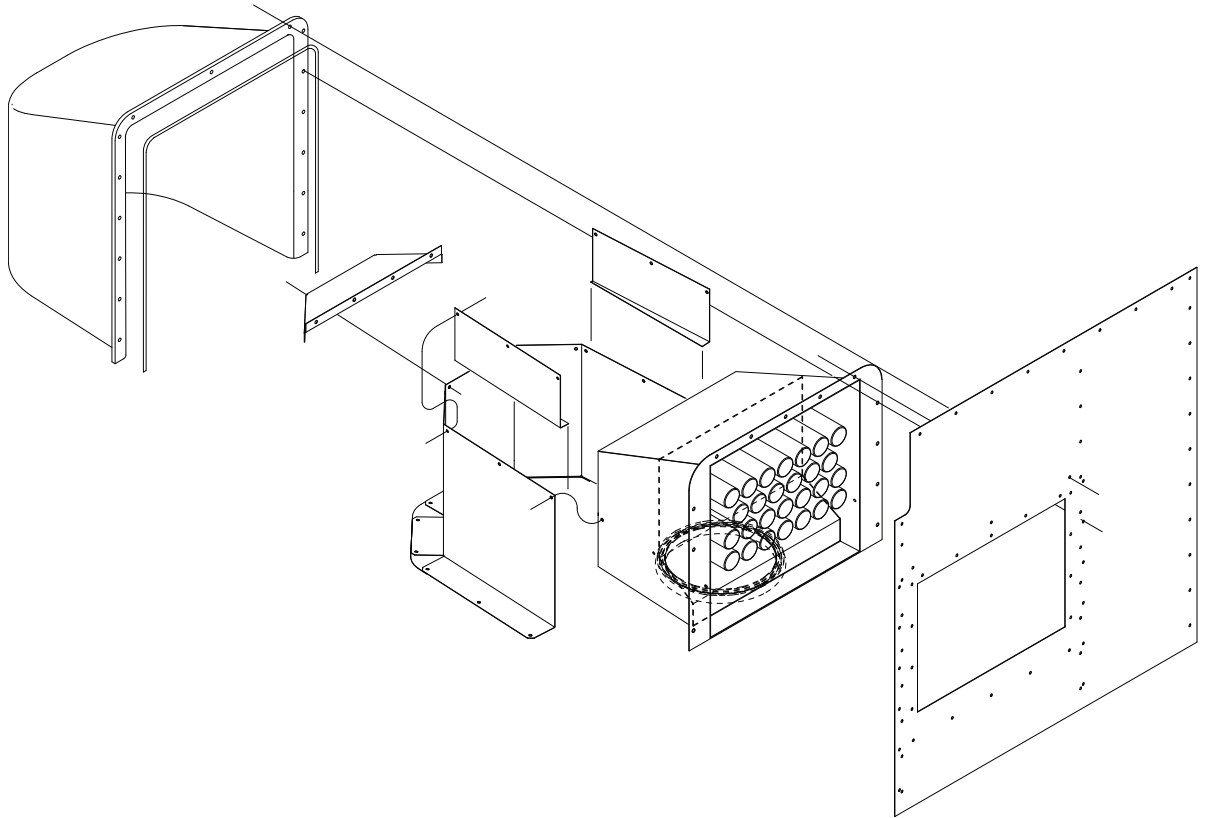

699

0052694c

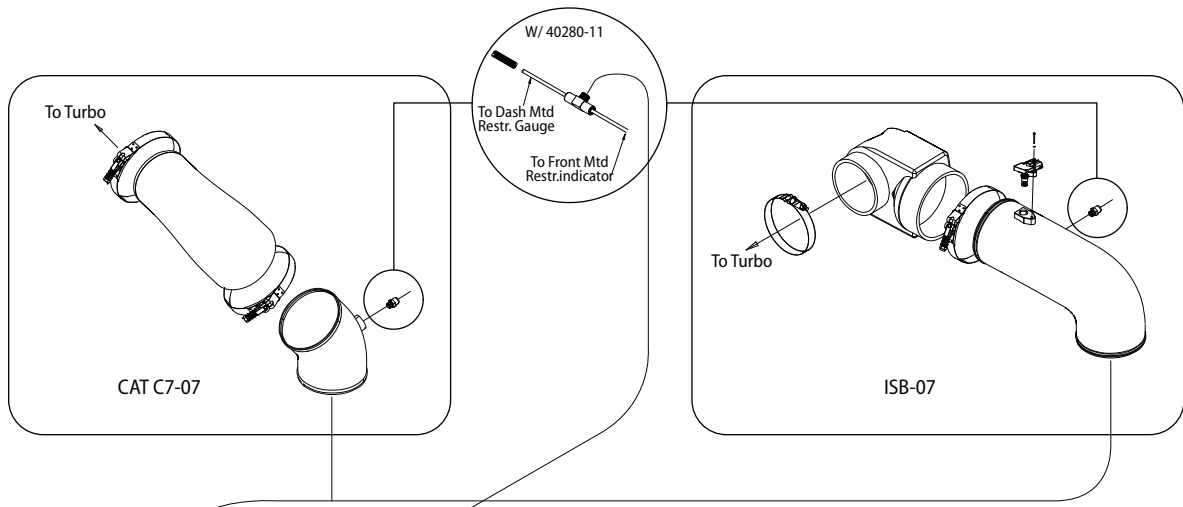

700

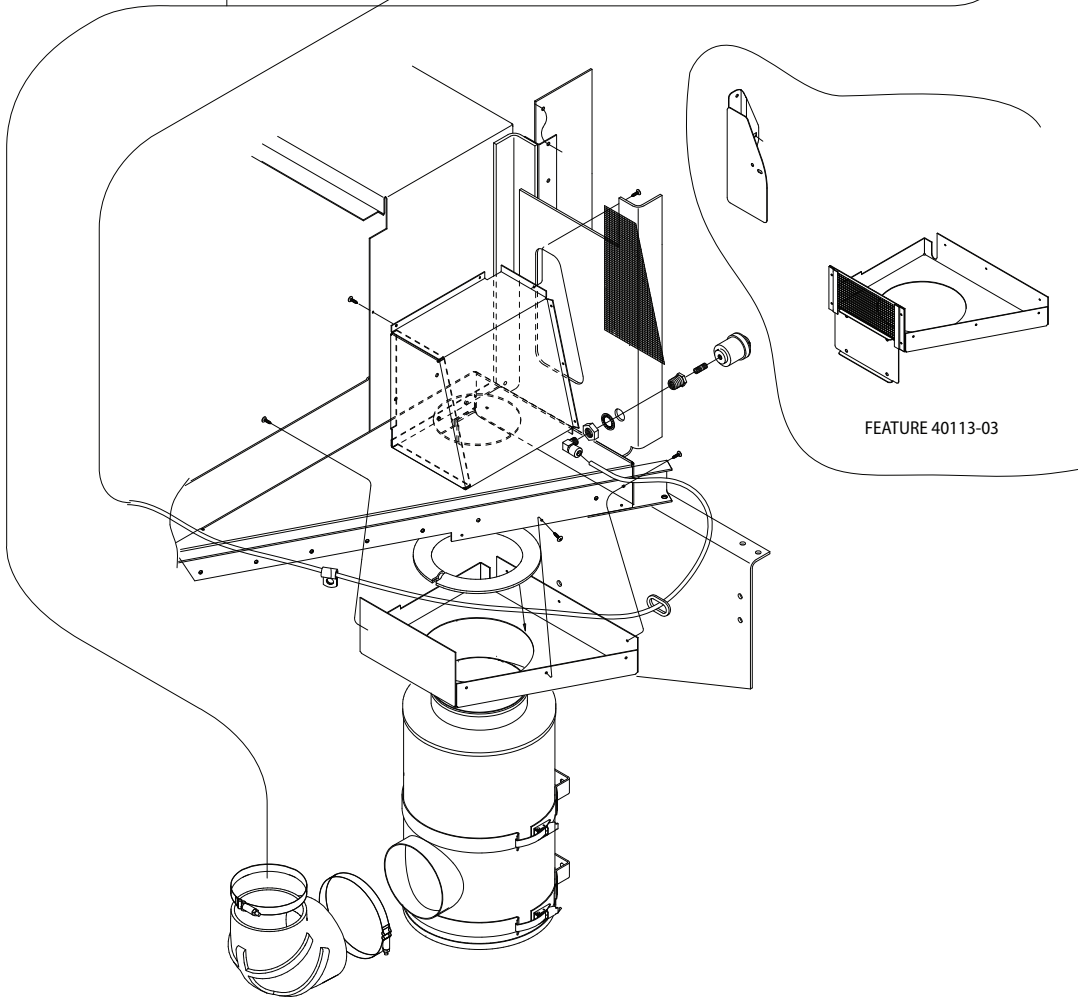

Intake Tract: A3FE With Cat C7 & ISB

0108398D

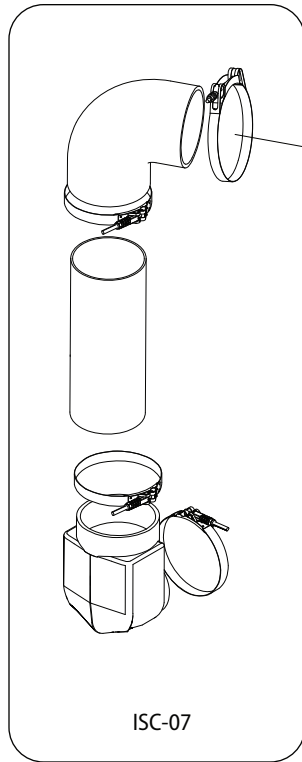
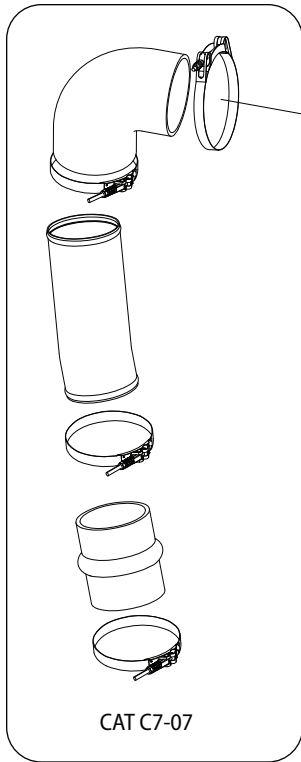

701

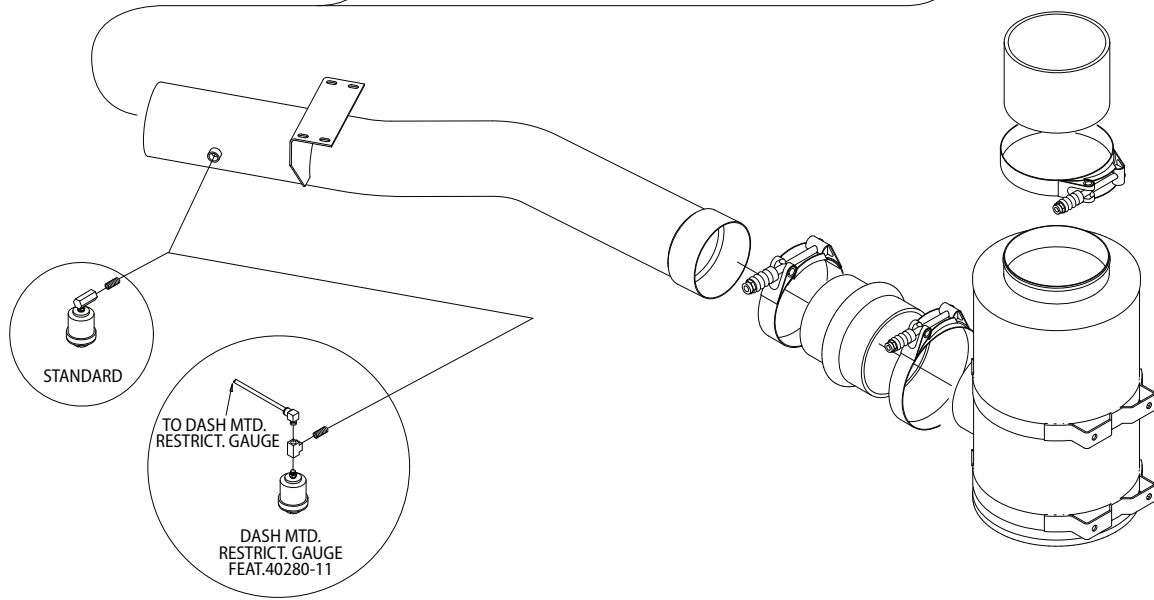

0111836A

Intake Tract: A3RE With Cat C7 & ISC



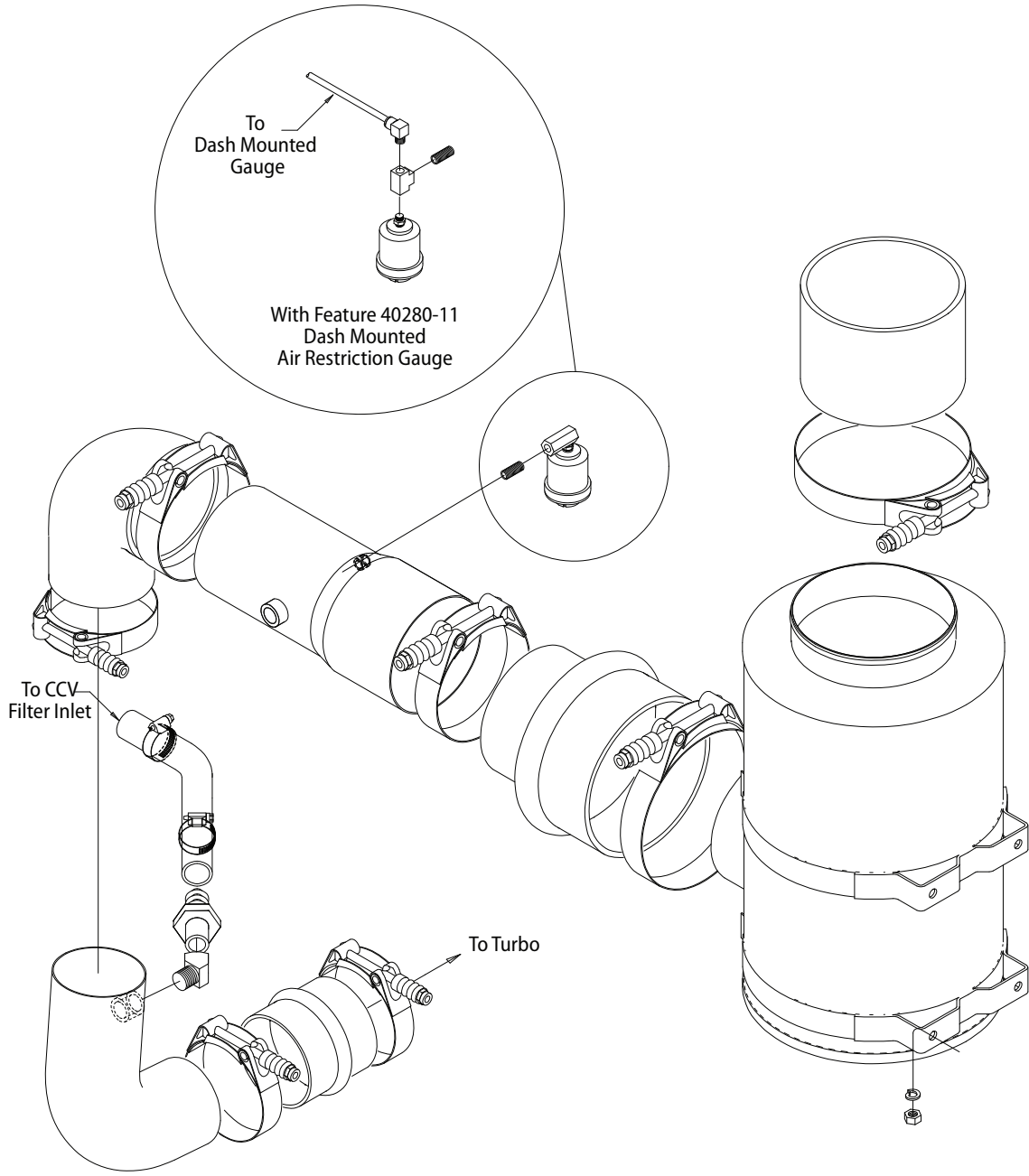

Intake Tract: A3RE With John Deere 8.1

0041893H

INTAKE & EXHAUST



Cummins Regeneration

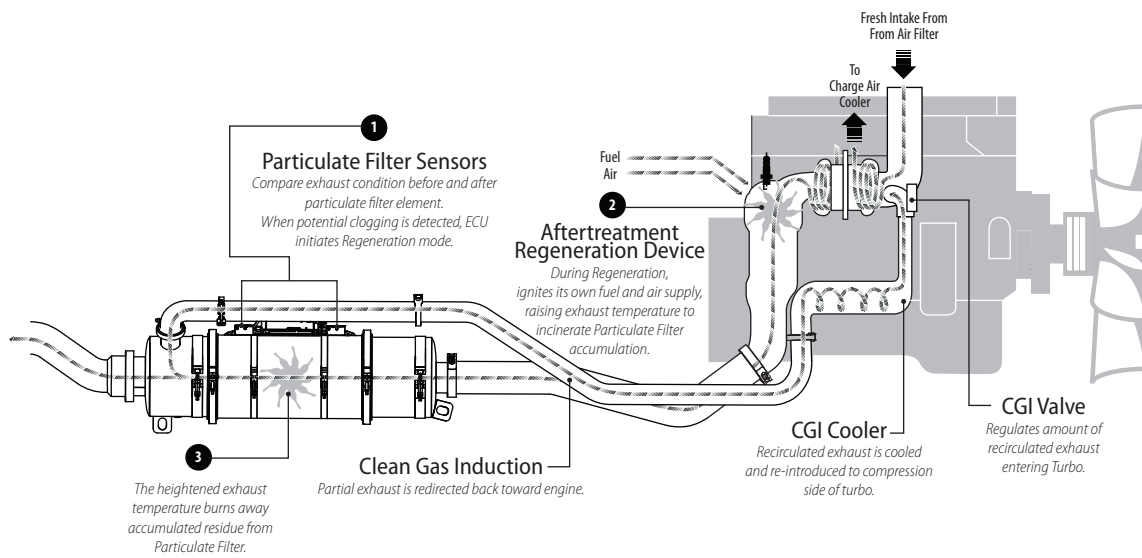
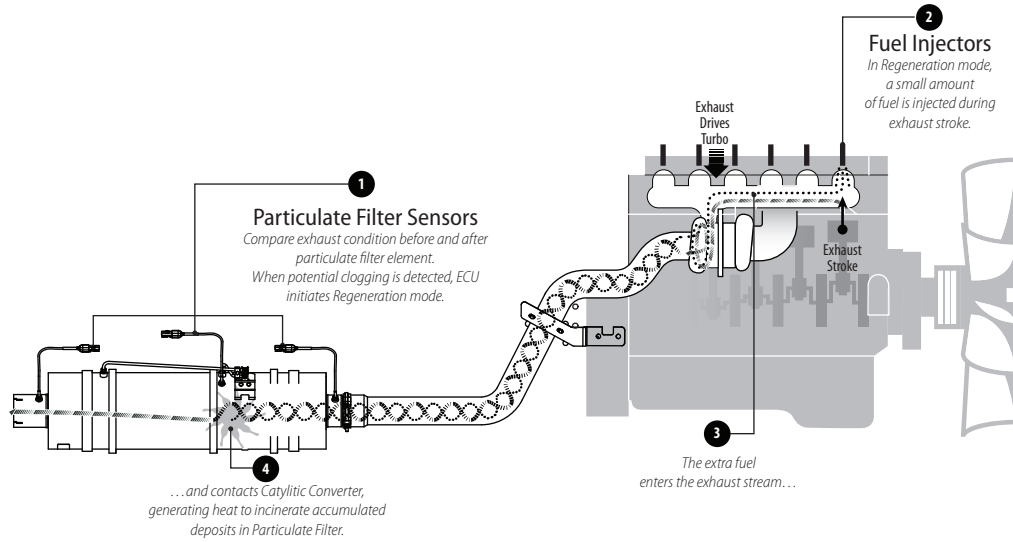

Caterpillar Regeneration



Exhaust System

New federally mandated emission standards affect all buses equipped with 2007 or newer diesel engines. The exhaust systems of both Caterpillar and Cummins engines in Blue Bird buses are *aftertreatment* systems which incorporate *Diesel Particulate Filters* (DPF) instead of ordinary mufflers. These sophisticated exhaust systems reduce emissions by trapping exhaust-borne particulates (soot) in a filter built into the DPF.

Over time, the trapped soot accumulates in the DPF, and must be removed by a process referred to as *regeneration*. Regeneration is conceptually similar to the cleaning mode of a self-cleaning oven in that heat is required to remove the soot. Regeneration converts most of the accumulated soot to carbon dioxide, and leaves behind a small amount of ash. Because of the higher operating temperatures involved, the exhaust system components are now more insulated from other chassis components than in previous years.

The rate at which the soot accumulates is dependent upon multiple conditions including the quality of the diesel fuel, type of engine oil, ambient temperature, engine load, and other factors. Regeneration occurs in three ways:

- Some regeneration occurs “naturally” whenever operating conditions (speed, engine load, etc.) result in exhaust system temperatures high enough to oxidize accumulated soot. Terminology differs between engine manufacturers, but this unassisted regeneration mode can generically be referred to as “passive” regeneration.
- Regeneration can be caused by raising the temperature of the exhaust system. A set of sensors mounted on the DPF assembly enable the Engine Control Module (ECM) to monitor the buildup. The ECM then automatically activates and de-activates a system designed to increase exhaust temperature when the ECM senses that regeneration is needed, and when certain requirements, including a minimum travel speed, are met. Although the specific mechanisms differ, both Caterpillar and Cummins engines are equipped with such systems. This automatic “heat assisted” mode can be generically referred to as “active” regeneration.
- Regeneration can be manually activated by means of a switch. This procedure is generically referred to as “stationary” regeneration, and should only be performed by or under the direction of a qualified service technician, and in a controlled environment to avoid the potential for human injury or fire hazards.

The ECM communicates the need for regeneration to the driver by a set of visual and audible signals in the instrument panel. An additional alert, the High Exhaust System Temperature (HEST) indicator, notifies the driver whenever exhaust system temperature is high due to recent regeneration.

Periodically, the normal ash accumulation which results from the regeneration process must be removed from the DPF, using equipment designed for the purpose at qualified engine service facilities. Refer to the engine manufacturer’s documentation for these service intervals.

CAUTION In 2007 diesel engines, use only diesel fuel labeled *Ultra Low Sulfur*, per the engine manufacturer’s specifications.

In Caterpillar, use oils meeting *API CJ-4* or *Caterpillar ECF-3* compliant. See *Caterpillar Operation and Maintenance Manual SEBU8083-08* for details.

In Cummins, use oils meeting *API CJ-4/SL* and *Cummins Engine Standard CES-20081*. See *Cummins Owners Manual ISB 6.7L CM2150* for details.

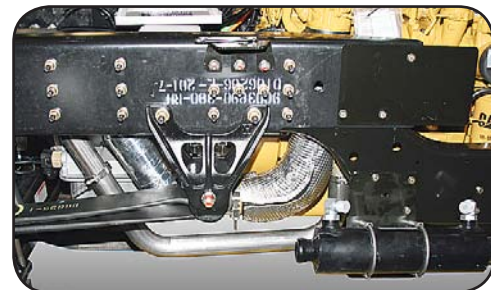

The exhaust systems of 2007 and newer engines incorporate engine-specific Diesel Particulate Filters, which operate at higher temperatures during their Regeneration cycles. The front exhaust pipes are insulated, and heat shields are installed at locations along the exhaust tubing. (Caterpillar shown.)

Engine-Specific Technologies

Although the purpose and general principles of aftertreatment exhaust systems are similar, both the terminology and the mechanisms to perform “active” regeneration differ among engine manufacturers.

Caterpillar and Cummins have also each developed their own technologies for accomplishing and controlling the active regeneration process. The engine-specific ECMs which control the process are different. Differences also exist between engine manufacturers in the construction of the DPF units, the exhaust flow paths, and other related components. It is for these reasons that the service technician must now regard that portion of the exhaust system from the engine to the outlet port of the DPF as part of the engine package itself.

This chapter provides separate conceptual explanations of the Caterpillar and Cummins systems. *However, the service technician must refer to the engine manufacturer's operators' manual and service literature regarding service and maintenance of the 2007 and newer exhaust systems.*

Regeneration Process In Caterpillar Engines

2007 emissions standards-compliant Caterpillar engines incorporate the Caterpillar Regeneration System (CRS). Exhaust leaving the turbo flows through an Aftertreatment Regeneration Device (ARD) mounted on the right side of the engine. The ARD is a chamber equipped with its own fuel injector, air intake, and spark plug.

Caterpillar Passive Regeneration

As the engine runs, exhaust merely passes through the ARD on its way to the exhaust pipe and into the DPF. If the engine's duty cycle generates sufficient heat, some of the soot accumulation is removed, even though the ARD is not activated. This unassisted regeneration mode is called *Passive Regeneration*.

At moderate and continuous speeds or engine load conditions, normal exhaust temperatures may be maintained at a high enough level for Passive Regeneration to “hold its own” against additional accumulation. Under frequent or prolonged moderate-to-heavy operating conditions, Passive Regeneration may even “gain ground” against the accumulation.

Caterpillar Active Regeneration

Accumulation occurs most at low speeds and relatively low temperatures. Frequent stop-and-go and continual low-speed operation typical of some school bus routes may not generate sufficient heat for Passive Regeneration to keep the DPF clear.

Sensors monitor the pressure differential before and after the DPF, and also monitor temperature. The pressure and temperature data is communicated to the ECM. When the readings indicate that the particulate filter is beginning to become restricted, the ECM may signal the system to enter *Active Regeneration* mode.

During Active Regeneration, a small amount of fuel and air is injected into the ARD, and is ignited by its spark plug. This combustion within the ARD raises the temperature of the exhaust flow sufficiently to remove the residue downstream in the DPF. This process occurs automatically and as-needed during normal operation.



Active Regeneration only occurs if DPF accumulation has reached a certain level, and if the bus is moving above a preset speed threshold (20 mph). If the bus is operated long enough (typically 20-30 minutes) at a speed above the Active Regeneration speed threshold, the accumulation clears and Active Regeneration mode stops. If the bus is slowed to below a certain speed threshold while in Active Regeneration mode, the Active Regeneration stops, even if the cleaning process has not completed. If the bus slows or stops while the exhaust system temperature is still high due to recent Active Regeneration, the HEST indicator appears on the driver's instrument panel to notify the driver that the system is hot.

Caterpillar Stationary Regeneration

Active Regeneration removes the accumulation at an increased rate. However, each time the bus slows to below the Active threshold, and each time exhaust temperature drops below that at which Passive Regeneration occurs, accumulation has opportunity to increase.

Therefore, depending upon the operating conditions, there may not be sufficient opportunity or duration for either Passive or Active Regeneration to keep the filter clear, and a *Stationary Regeneration* must eventually be performed.

During Stationary Regeneration, temperatures inside the exhaust can exceed 1200°F. Stationary Regeneration must be performed only in a controlled environment where all reasonable precautions are taken to avoid any hazard that might result from the elevated temperatures. Blue Bird strongly recommends that Stationary Regeneration be performed only by, or under the supervision of, a qualified service technician. Read carefully the section titled **Stationary Regeneration Precautions**.

Stationary Regeneration is initiated by means of a momentary toggle switch. Operating the switch starts a Stationary Regeneration only if certain conditions are true: The ECM must have indicated that regeneration is needed (as indicated by the appearance of the DPF indicator); the bus must be stopped with parking brake on; the engine must be running; and the transmission must be in Neutral.

During a Stationary Regeneration procedure, the process is monitored and controlled by the ECM and CRS. The Stationary Regeneration process continues until the filter is clean, and then stops. The bus may then be returned to normal service. (For more information, see **DPF Regeneration In Blue Bird Buses**.)

Clean Gas Induction in Caterpillar Engines

The exhaust system of the Caterpillar C7 engine also utilizes Clean Gas Induction (CGI). A portion of the exhaust is "recycled" through the engine to help control emissions. Just before the DPF outlet, a portion of the exhaust gases is re-directed back toward the engine through a 2 ½" tube. This inert exhaust enters a CGI Cooler, located on the right side of the engine, below the turbo and forward of the ARD. Enveloped in the engine coolant circuit, the CGI Cooler lowers the temperature of the incoming exhaust. The cooled exhaust flow then re-enters the compressor side of the turbo-charger through an electrically-controlled, hydraulically-actuated mixing valve, and is re-introduced into the intake flow.

WARNING *The aftertreatment regeneration process can cause extremely high exhaust gas temperatures hot enough to ignite or melt common materials, and to burn people.*

Carefully read, understand, and abide by all instructions, warnings, and cautions in the engine manufacturer's operator's manual (and other related engine manufacturer's literature) regarding safe operation when the HEST indicator is on.

Carefully read, understand, and abide by all instructions, warnings, and cautions in the engine manufacturer's operator's manual (and other engine manufacturer's literature) regarding safety conditions when performing Stationary regeneration.

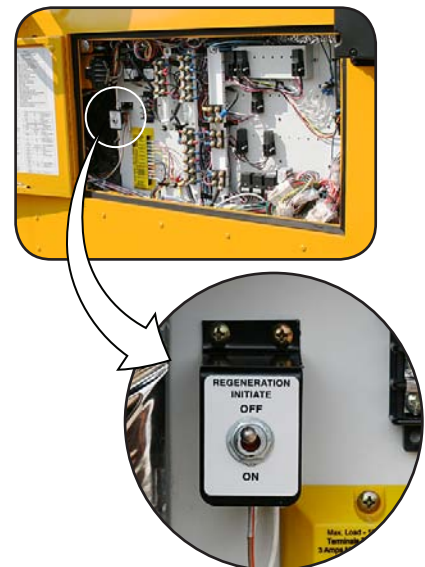

Regeneration switch for use by Service Technicians performing Stationary Regeneration only in a controlled, fire-hazard-free environment.

Regeneration Process In Cummins Engines

2007 emissions standards-compliant Cummins engines incorporate the Cummins Aftertreatment System. When elevation of exhaust temperature is needed to facilitate regeneration, this system utilizes the engine's fuel injectors to inject a small measure of fuel during the exhaust strokes of the engine's cycle.

Cummins Passive Regeneration

When driving at high speeds or with heavy loads, the exhaust system is hot enough to turn soot accumulation inside the DPF into carbon dioxide. Temperatures generated in this mode are comparable to those of pre-2007-standards engines.

At moderate and continuous speeds or engine load conditions, normal exhaust temperatures may be maintained at a high enough level for normal operation to "hold its own" against additional accumulation. At moderate-to-heavy operating conditions, normal exhaust heat may even "gain ground" against the accumulation.

Cummins Active Regeneration

Accumulation occurs most at low speeds and relatively low temperatures. Frequent stop-and-go and continually low-speed operation typical of some school bus routes may not always generate sufficient heat for normal running to keep the particulate filter clear.

Sensors monitor the pressure differential before and after the DPF, and also monitor temperature. The pressure and temperature data is communicated to the ECM. When the pressure / temperature readings indicate that the particulate filter is beginning to become restricted, the ECM may signal the system to enter *Active Regeneration* mode.

During Active Regeneration, a small amount of fuel is injected into the exhaust stream by the engine's fuel injectors during the engine's exhaust stroke. This fuel reacts with the catalytic converter in the DPF, raising the temperature of the exhaust flow sufficiently to remove the residue. This process activates and deactivates automatically and as-needed during normal operation.

Active Regeneration begins only if DPF accumulation has reached a certain level, *and* if the bus is moving above a preset speed threshold (approximately 40 mph). If the bus is operated above the speed threshold long enough, the accumulation clears and Active Regeneration mode stops.

If the bus is slowed to below a certain speed threshold while in Active Regeneration mode, the Active Regeneration stops, even if the cleaning process has not completed. If the bus slows or stops while the exhaust system temperature is still high due to recent Active Regeneration, the HEST indicator appears on the driver's instrument panel to notify the driver that the system is hot.

Cummins Stationary Regeneration

Active Regeneration removes the accumulation at an increased rate. However, each time the bus slows to below the cut-off threshold, and each time exhaust temperature drops to levels insufficient for soot to be cleared, accumulation has opportunity to increase.

Depending upon the operating conditions, there may not be sufficient opportunity or duration for either normal running or Active Regeneration to keep the filter clear, and a Stationary Regeneration must eventually be performed.

During Stationary Regeneration, temperatures inside the exhaust can exceed 1300°F. Stationary Regeneration must be performed in a controlled environment where precautions are taken to avoid any hazard that might result from the elevated temperatures. Blue Bird strongly recommends that Stationary Regeneration be performed only by, or under the supervision of, a qualified service technician. Read carefully the section titled **Stationary Regeneration Precautions**.

Stationary Regeneration is initiated by means of a momentary toggle switch. Operating the switch starts a Stationary Regeneration only if certain conditions are true: The ECM must have indicated that Regeneration is needed (as indicated by appearance of the DPF indicator); the bus must be stopped with parking brake on; the engine must be running; and the transmission must be in Neutral. During a Stationary Regeneration procedure, the process is monitored and controlled by the ECM. Depending upon the severity of the restriction, the engine may or may not raise its idle speed. The Regeneration process continues until the filter is clean, and then stops. The bus may then be returned to normal service. (For more information, see **DPF Regeneration In Blue Bird Buses**.)

Cummins Exhaust Gas Recirculation

In the Cummins ISB engine, a portion of the exhaust is “recycled” through the engine to help control emissions. A device on the engine exhaust system routes a small amount of the exhaust stream through a cooler, mixes it with fresh air, and re-introduces it into the intake stream. This helps lower the temperature during combustion, which reduces the formation of Nitrous Oxides.

WARNING *The aftertreatment regeneration process can cause extremely high exhaust gas temperatures hot enough to ignite or melt common materials, and to burn people.*

Carefully read, understand, and abide by all instructions, warnings, and cautions in the engine manufacturer's operator's manual (and other related engine manufacturer's literature) regarding safe operation when the HEST indicator is on.

Carefully read, understand, and abide by all instructions, warnings, and cautions in the engine manufacturer's operator's manual (and other engine manufacturer's literature) regarding safety conditions when performing Stationary regeneration.

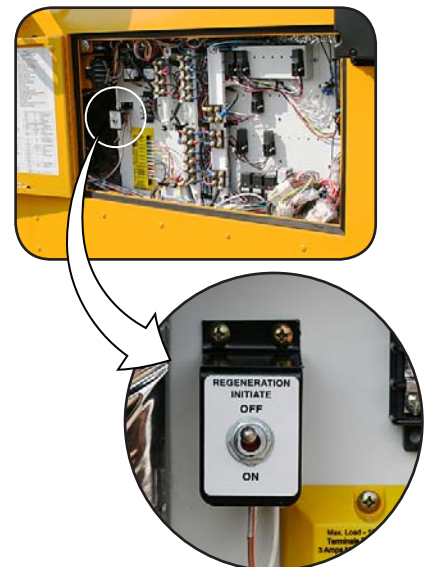

Regeneration switch for use by Service Technicians performing Stationary Regeneration only in a controlled, fire-hazard-free environment.

DPF Regeneration In Blue Bird Buses

As with most new mechanical processes, the introduction of more sophisticated exhaust systems in 2007 emission standards-compliant engines has generated some degree of initial confusion. Engine manufacturers have designed their own methods to accomplish the regeneration (cleaning) of the DPF, and therefore describe the process in somewhat differing terms.

Whether your Blue Bird bus is equipped with a Caterpillar or Cummins engine, neither system is complicated. Nor should the regeneration process be regarded with alarm. Both Drivers and service technicians should be at least conceptually familiar with the regeneration process.

As soot builds up in the DPF filter, the driver is notified in several stages by visual and audible alerts. The alert system is designed to provide reasonable and comfortable fore-warning and adequate opportunity for the needed regeneration. As the need for regeneration becomes more severe, the alerts become increasingly imperative; and the penalty for postponing the needed regeneration also increases.

When the earliest alerts occur, there is typically ample time to complete a route and then have a Stationary Regeneration procedure performed at a proper facility. If early alerts are ignored, and the condition is allowed to worsen, the engine will eventually de-rate automatically, and performance will reduce noticeably. If the condition is allowed to become severe, a Stationary Regeneration may not be possible, and the DPF may require removal and treatment using specialized equipment. Therefore, to minimize disruption of your bus operation, the regeneration-related alerts should be heeded and responded to at their early stages as a matter of routine.

Aftertreatment Terms

The following summarizes some of the terms associated with the exhaust systems of Blue Bird buses equipped with 2007 emission standards compliant engines. Both the driver and technician should become familiar with the following terms:

Aftertreatment. The process of highly filtering engine exhaust in order to reduce emissions, and of purging the exhaust system of accumulated exhaust residue.

DPF (Diesel Particulate Filter). A component in the exhaust system which takes the place of a traditional muffler. A DPF contains a special dissimilar metals filter which traps particulate accumulation (soot), which is then converted to carbon dioxide by the aftertreatment process. The Cummins DPF also contains a catalytic converter.

Regeneration. The process of cleaning accumulated soot from the filtering components inside the DPF. Regeneration occurs at high exhaust system temperatures to turn the soot into carbon dioxide gas. Regeneration can be thought of as conceptually similar to the clean cycle of a self-cleaning oven.

ARD (Aftertreatment Regeneration Device). A component of the Caterpillar Regeneration System, located on the right side of the engine, at the outlet of the turbocharger. The ARD is controlled by the engine's ECM and is activated when regenera-

WARNING Postponing regeneration beyond the early indications may result in the engine being automatically de-rated, and reduction of power while driving.

WARNING The aftertreatment regeneration process can cause extremely high exhaust gas temperatures hot enough to ignite or melt common materials, and to burn people.

Carefully read, understand, and abide by all instructions, warnings, and cautions in the engine manufacturer's operator's manual (and other related engine manufacturer's literature) regarding safe operation when the HEST indicator is on.

Carefully read, understand, and abide by all instructions, warnings, and cautions in the engine manufacturer's operator's manual (and other engine manufacturer's literature) regarding safety conditions when performing Stationary regeneration.



tion needs to occur and the necessary conditions are met. When not in regeneration mode, the ARD is simply a chamber through which the exhaust flows. During regeneration, a charge of fuel and air is ignited in the ARD, and the resulting combustion creates additional heat to facilitate regeneration.

HEST Indicator (High Exhaust System Temperature). An instrument panel indicator which appears when the exhaust temperature is unusually high due to recent regeneration. This is a normal behavior of the aftertreatment system, intended to notify the driver and technician that the exhaust system temperature is high and that caution should be observed around the exhaust system.

DPF Indicator. An instrument panel indicator which displays when particulate accumulation has reached a preset level in the DPF, and regeneration is needed. The bus should either be operated with a more demanding duty cycle until the indicator goes off, or it should be scheduled for a Stationary Regeneration at a service facility.

Levels of Notification

Regeneration—the process which clears soot accumulation in the DPF—occurs automatically as the bus is operated, as long as certain operating conditions (such as minimum speed thresholds) are met. When bus operating conditions do not provide adequate opportunity for the regeneration system to keep the DPF clear, soot begins to accumulate. A system of driver alerts keeps the driver informed of when the exhaust system is in need of regeneration, and of high exhaust temperature associated with regeneration. Several levels of regeneration alerts occur in sequence, each indicating a more imperative warning.

High Exhaust Temperature Notification

The High Exhaust System Temperature (HEST) indicator appears to alert the driver when exhaust temperature is unusually high and that prudent judgement should be applied regarding the proximity of people or combustibles to the exhaust system. For example, the bus should not be parked on a surface of grass or weeds. The conditions under which the HEST indicator appears differ between Caterpillar- and Cummins-equipped buses:

With Caterpillar engine, the HEST indicator appears whenever the exhaust temperature is high (842°F or above), and the bus is either stopped or moving at a slow speed (approximately 5 MPH).

With Cummins engine, the HEST indicator appears whenever the exhaust temperature is high (752°F or above), regardless of moving speed.

The driver should be familiar with and abide by all instructions, warnings, and cautions in the engine manufacturer's operator's manual regarding safe operation when the HEST indicator is on.

- The HEST alert appears in the instrument panel.
- The audible alarm sounds one beep.

HEST Notification



The HEST alert appears in the instrument panel's warning bank.



The audible alert sounds one beep.

Level 1 Regeneration Notification: DPF Indicator Appears

In low-demand operating conditions, it is possible that the regeneration system does not have sufficient opportunity to prevent particulate build-up in the DPF. The ECM senses that accumulation is occurring and that regeneration is needed. The driver is notified as follows:

- The DPF Regeneration alert activates.
- The audible alert sounds one beep.

The above indicates that regeneration of the DPF is needed at the earliest convenience. The regeneration can be accomplished in either of two ways: If practical, the bus could simply be operated for a while at a speed above the automatic regeneration threshold; or the bus could be taken to a suitable location to have a Stationary Regeneration procedure performed.

If the bus is operated at a minimum highway driving speed (20 mph Caterpillar; 40 mph Cummins), the automatic regeneration system will activate. If minimum speed is maintained long enough (usually 20-30 minutes), the automatic regeneration mode can likely reduce the soot sufficiently to cause the DPF Icon to go off.

Therefore, the first appearance of the DPF icon should be perceived by the driver as a normal notification of action that needs to be taken, but not as an emergency situation. Typically, even if the bus route does not afford immediate opportunity for higher-speed operation, there is sufficient time to finish the bus route and return to the bus maintenance shop before the higher level of notification occurs. Exactly how much “warning time” the first appearance of the DPF indicator represents is dependant upon specific operating conditions. However, current data from Cummins suggest that, at this level of notification, the DPF needs to undergo regeneration within the next two to six hours of bus operation. If regeneration does not begin, a more imperative notification will activate.

Level 2 Notification: DPF Indicator Blinks

If the bus continues to be operated without taking the measures indicated by a Level 1 Notification (described above), particulate accumulation continues, and a more imperative notification occurs:

- The DPF Regeneration alert begins to flash.
- The audible alarm sounds continuously.
- The engine may be automatically de-rated.

The above indications should be interpreted as a more imperative alert that the exhaust system is in need of regeneration soon. As soon as practical, the bus should be operated at or above the minimum speed needed to allow automatic regeneration to activate, or a Stationary Regeneration must be performed. Again, situation-specific variables apply. Current data from Cummins suggest that at this level of notification, the DPF needs to be regenerated within the next one to two hours of bus operation. Otherwise, the third level of notification will occur.

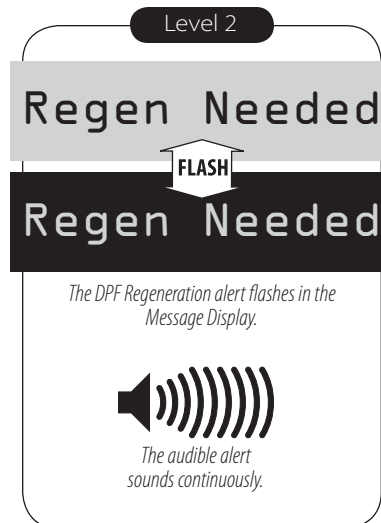
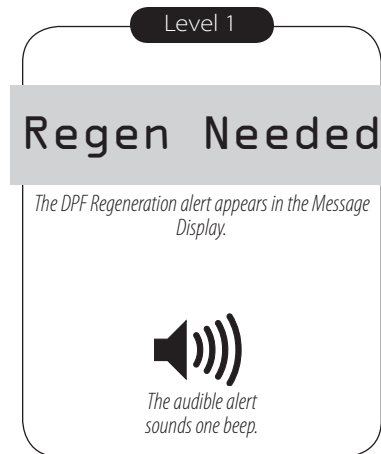



Level 3 Notification: Check Engine Indicator Appears

If the bus continues to be operated without taking the measures indicated by a Level 2 Notification, particulate accumulation worsens. These indicators are activated:

- The DPF Regeneration alert continues to flash.
- The audible alert sounds continuously.
- The engine is automatically de-rated.
- The Check Engine alert appears.

The above indicates that a Manual Regeneration must be performed as soon as possible. Because the engine is automatically de-rated it may not be possible to drive at sufficient speed to cause active regeneration to occur.

With Cummins engine, depending upon the severity of the accumulation, the regeneration switch may not be allowed to initiate a regeneration without use of Cummins’s PC-based diagnostic software, Insite.

Level 4 Notification: Stop Engine Indicator Appears

If the bus continues to be operated without taking the measures indicated by a Level 3 Notification, particulate accumulation reaches a critical level. Engine power is automatically further de-rated by the ECM. The indicators differ slightly between Caterpillar- and Cummins-equipped buses:

Cummins:

- The DPF Regeneration alert deactivates.
- The audible alert sounds continuously.
- The engine is further de-rated.
- The Check Engine alert deactivates.
- The red Stop Engine alert appears.

Caterpillar:

- The DPF Regeneration alert continues to flash.
- The audible alert sounds continuously.
- The engine is further de-rated.
- The Check Engine alert remains on.
- The red Stop Engine alert appears.

The above indicates that accumulation has progressed to critical levels and the bus should be stopped with the engine off as soon as it is safe to do so. The bus should remain shut down until the aftertreatment system has been serviced.

With Cummins engine, the regeneration switch will not be allowed to initiate a regeneration without use of Cummins’s PC-based diagnostic software, Insite.

With Caterpillar engine, depending upon the severity of the accumulation, the regeneration switch may not be allowed to initiate a regeneration without the use of Caterpillar’s PC-based diagnostic software, Electronic Technician.

With either Caterpillar or Cummins engine, removal and cleaning of the DPF using specialized equipment may be required.

Level 3

Regen Needed

FLASH

Regen Needed

The DPF Regeneration alert flashes in the Message Display.

The audible alert sounds continuously.

ENGINE WARN

The Check Engine alert appears in the warning bank..

Level 4, Cummins

The audible alert sounds continuously.

STOP ENGINE

The Stop Engine alert appears in the warning bank.

Level 4, Caterpillar

Regen Needed

FLASH

Regen Needed

The DPF Regeneration alert flashes in the Message Display.

The audible alert sounds continuously.

ENGINE WARN

The Check Engine alert appears in the warning bank..

STOP ENGINE

The Stop Engine alert appears in the warning bank.

Stationary Regeneration Precautions

During active regeneration, the exhaust system can reach extremely high temperatures. Automatic active regeneration, which occurs while driving the bus, is programmed to occur only when the bus is moving at a minimum speed, and it stops when the vehicle slows or stops.

With Caterpillar engine, if the exhaust is still unusually hot from recent regeneration when the bus slows or stops, the HEST indicator appears to remind the driver of the high temperature condition.

With Cummins engine, the HEST indicator appears whenever the high temperature condition exists.

When performing a Stationary Regeneration, the entire process occurs for an extended period while the bus is stopped. It is therefore critical that prudent human safety and fire hazard precautions are followed. Those precautions include:

- Read, understand, and abide by all the precautions pertaining to regeneration procedures in the engine manufacturer's Operator's Manual.
- If at all possible, the Stationary Regeneration procedure should be conducted at a service facility by trained technicians.
- The Driver's first priority is the safety of the passengers. If a Stationary Regeneration must unavoidably be done by the Driver under a qualified technician's direction, alternate transportation should be arranged first, or passengers should be removed under proper supervision to a location away from the bus.
- Select an appropriate location to park the vehicle.
 - Choose a surface that will not burn or melt under high temperature, such as clean concrete or gravel, *not grass or asphalt*.
 - Ensure that nothing that can burn, melt, or explode (gasoline, wood, paper, plastics, fabric, compressed gas containers, hydraulic lines) is near the exhaust outlet. Abide by all instructions, warnings, and cautions in the engine manufacturer's operator's manual regarding safe operation when performing a Stationary Regeneration.
- Park the bus securely.
 - Set the parking brake. Put the transmission in Neutral. Chock the wheels.



- Secure the exhaust area.
 - If bystanders might enter the area, set up barriers to keep people safely away from the exhaust outlet.
 - If the procedure is performed indoors at a service facility, attach an exhaust discharge pipe rated for at least 1500°F.
 - Keep a fire extinguisher nearby.
- Check exhaust system surfaces to confirm that no tools, rags, grease, debris or any other objects are on or near the exhaust system.
- Start the engine.
- Operate the Regeneration Switch to begin the regeneration process.
- Monitor the process. If any unsafe condition occurs, shut off the engine immediately. During the regeneration process, the engine may change speed, and the turbocharger may whistle. When the process is complete, the engine will return to normal idle speed. Exhaust gas and exhaust surface temperatures will remain elevated until they have had time to cool to normal levels.

Exhaust Piping

The exhaust system beyond the DPF is designed to move hot exhaust gases from the engine, underneath and toward the rear of the bus, while preventing contamination of the passenger area. All pipes and connections must be inspected for leaks at least monthly to provide continued safe transport of passengers.

CAUTION *Never work under a bus with the engine running. Never work under a bus until the wheels are chocked, to prevent movement in either direction.*

Although the exact configuration of exhaust pipe and tailpipe sections is dependent upon the wheelbase and body length of the particular bus, the pipe sections, joint clamps and suspension hangers from the particulate trap / muffler assembly are similar. As a general rule, to remove the exhaust system, or any part of it, start at the rear most hanger and work forward.

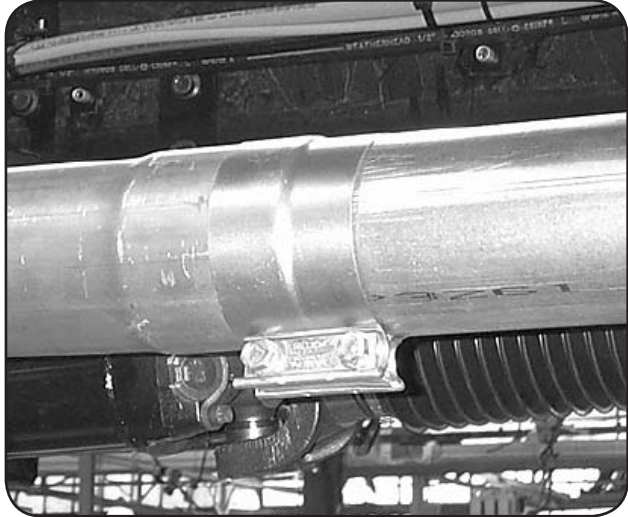

Typical Exhaust Clamp

DPF / Muffler Removal

When removing the DPF / muffler from an All American-Forward Engine, work from the rear fo the bus forward:

1. Start at the rear bumper and loosen all the sections forward until you reach the DPF / muffler.
2. Remove the wideband clamp securing the tailpipe onto the DPF / muffler.
3. With the slack produced by loosening the section clamps rearward, remove the tailpipe section nearest the DPF / muffler.
4. Loosen the nuts at the straps securing the DPF / muffler.
5. Support the DPF / muffler and remove the strap from the hanger.

Typical Exhaust Hanger

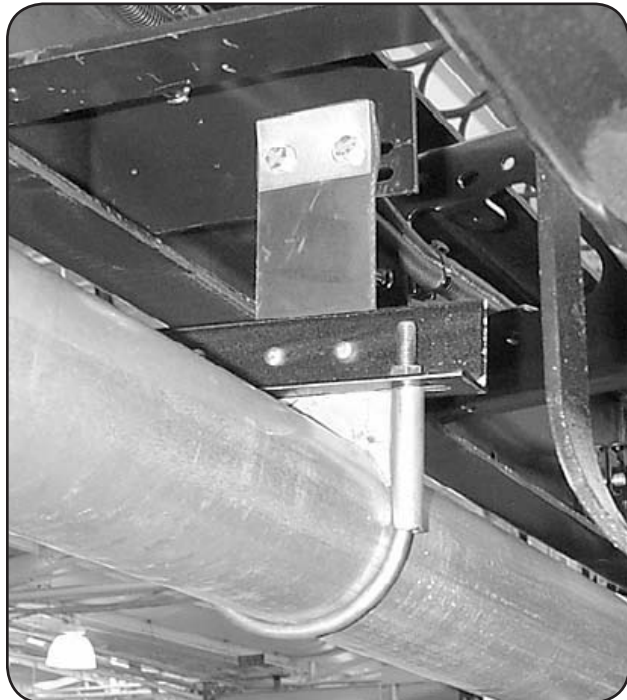

If it is necessary to continue removing exhaust pipe sections, proceed from the DPF / muffler toward the engine as far as necessary.

**DPF / Muffler Reinstallation**

When assembling the exhaust system, start at the forward most section and work toward the rear of the bus. Always use new clamps and hardware.

1. Assemble the exhaust pipe to the DPF / muffler. Leave all connectors loose for final adjustment.
2. Use new wideband clamps and hardware.
3. Tighten the strap holding the DPF / muffler.
4. Continue working toward the rear of the vehicle. Leave all joints loose until the entire tailpipe assembly is in the correct position, and then tighten all the clamps.

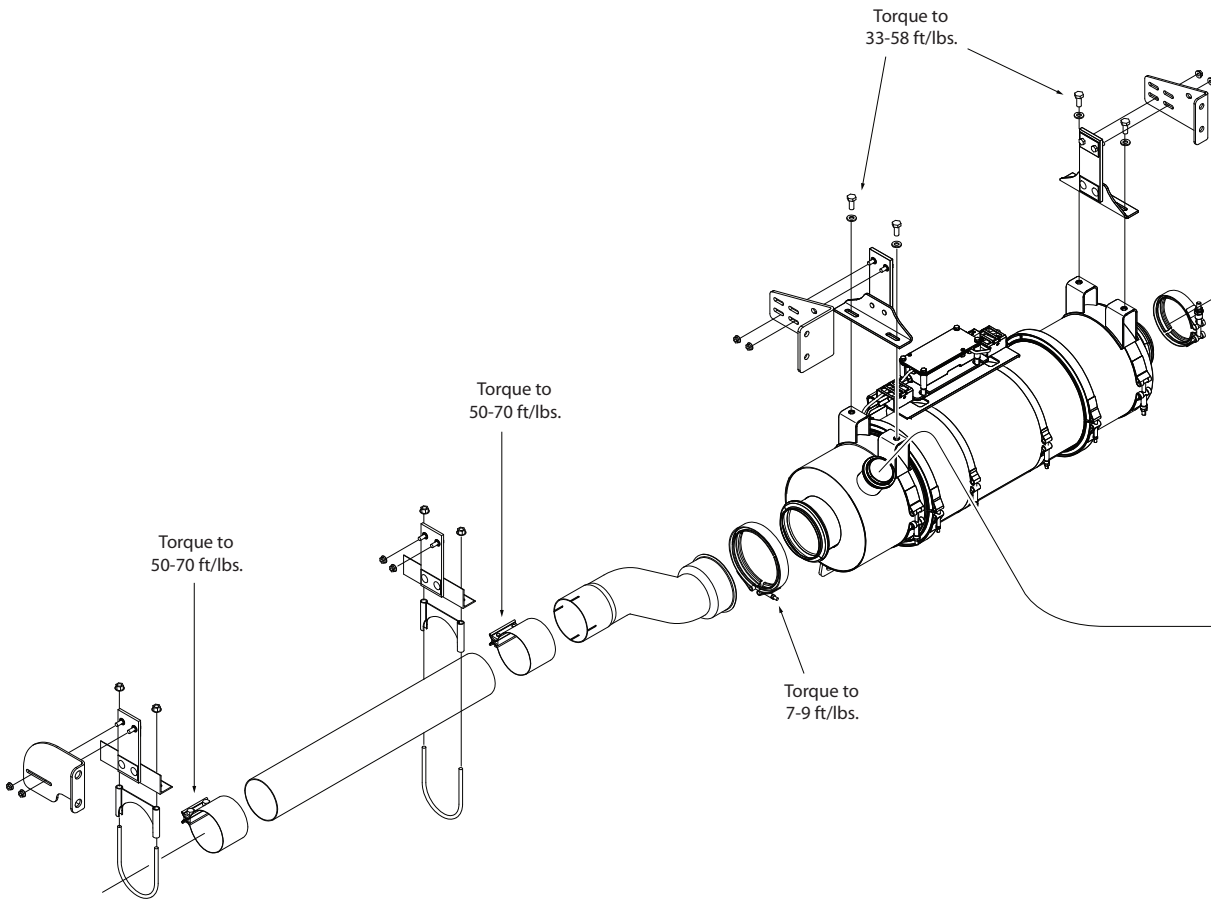

Exhaust, Main: A3FE With Cat C7

0116318B

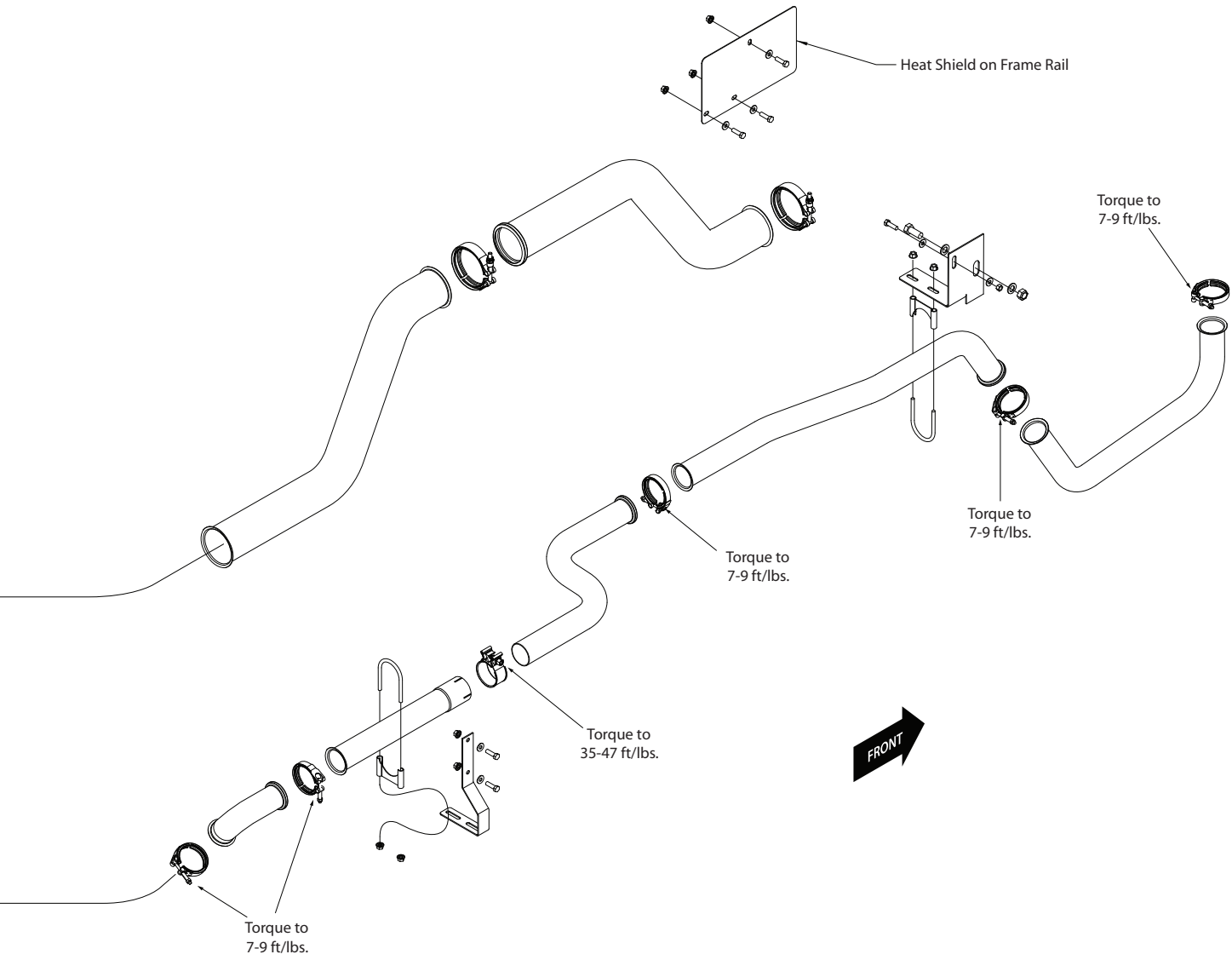

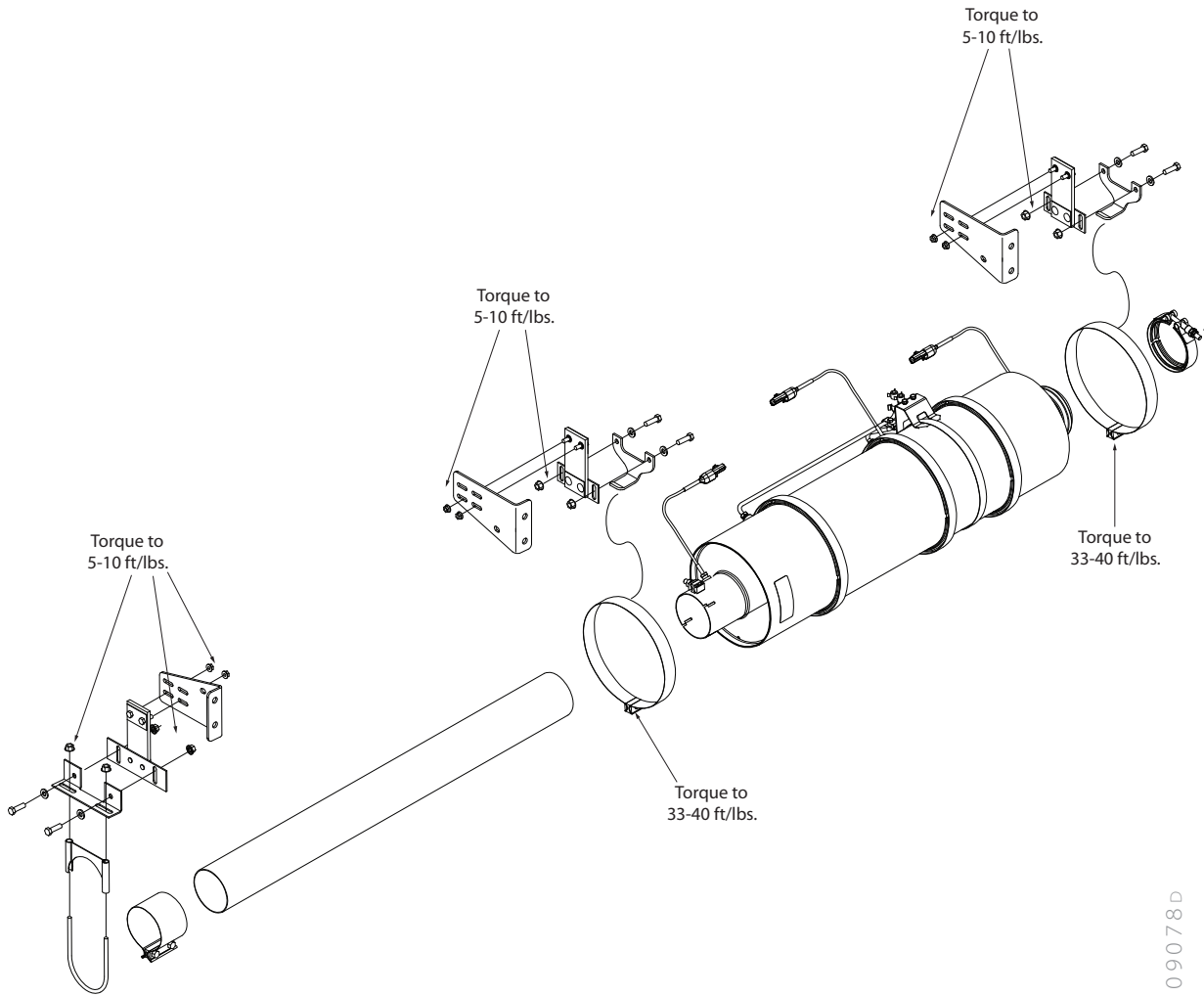

Exhaust, Main: A3FE With Cummins ISB

0109078D

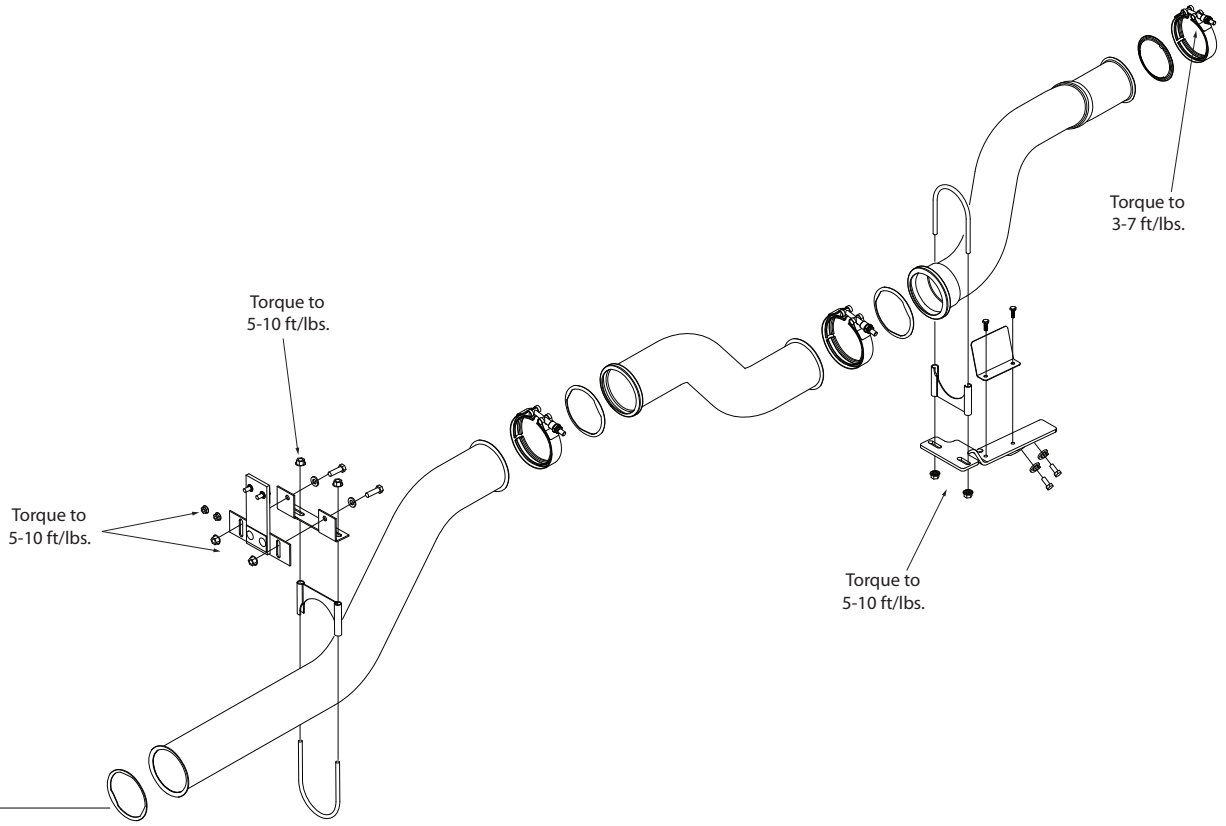

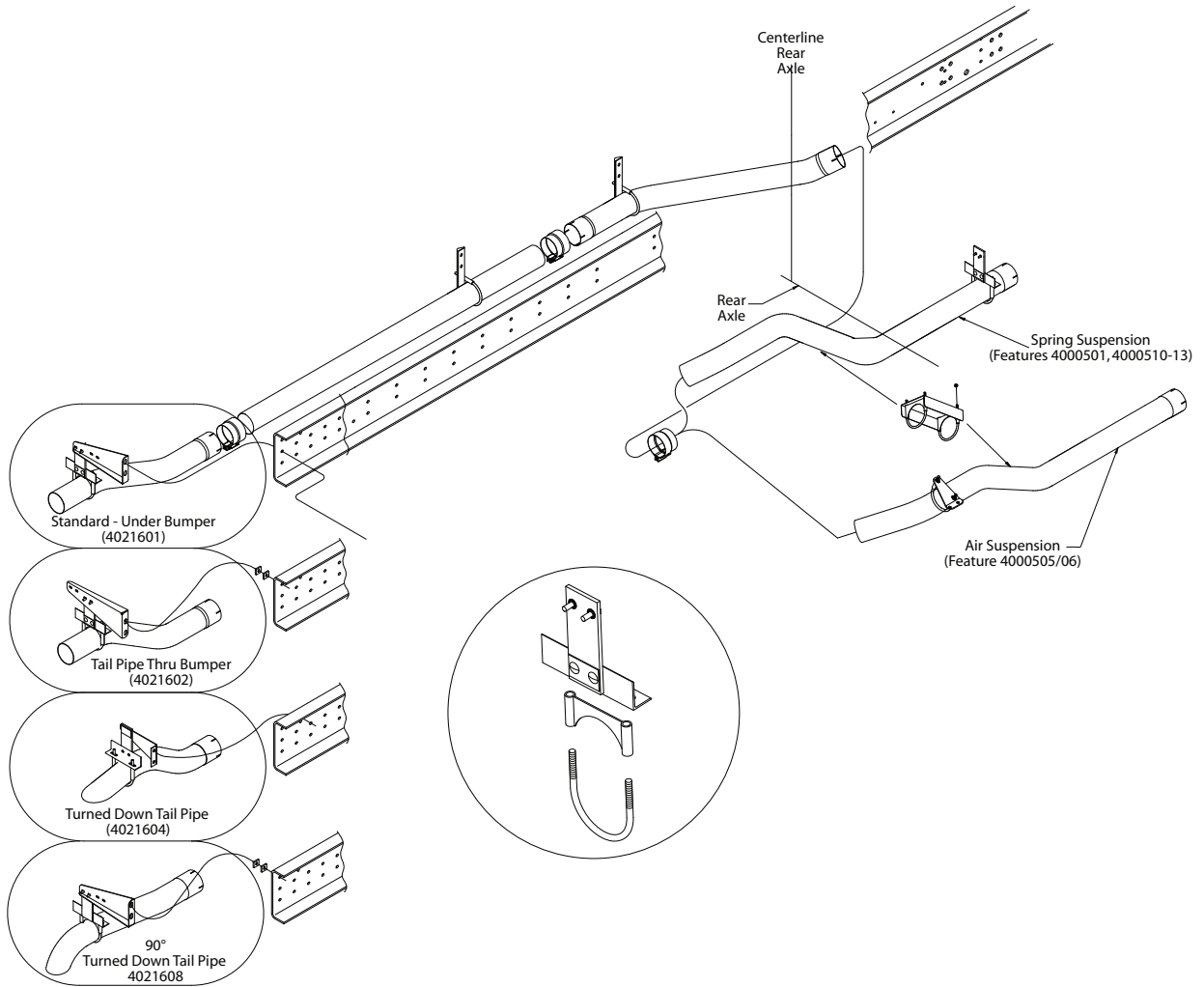

Exhaust, Rear: A3FE

0085324D

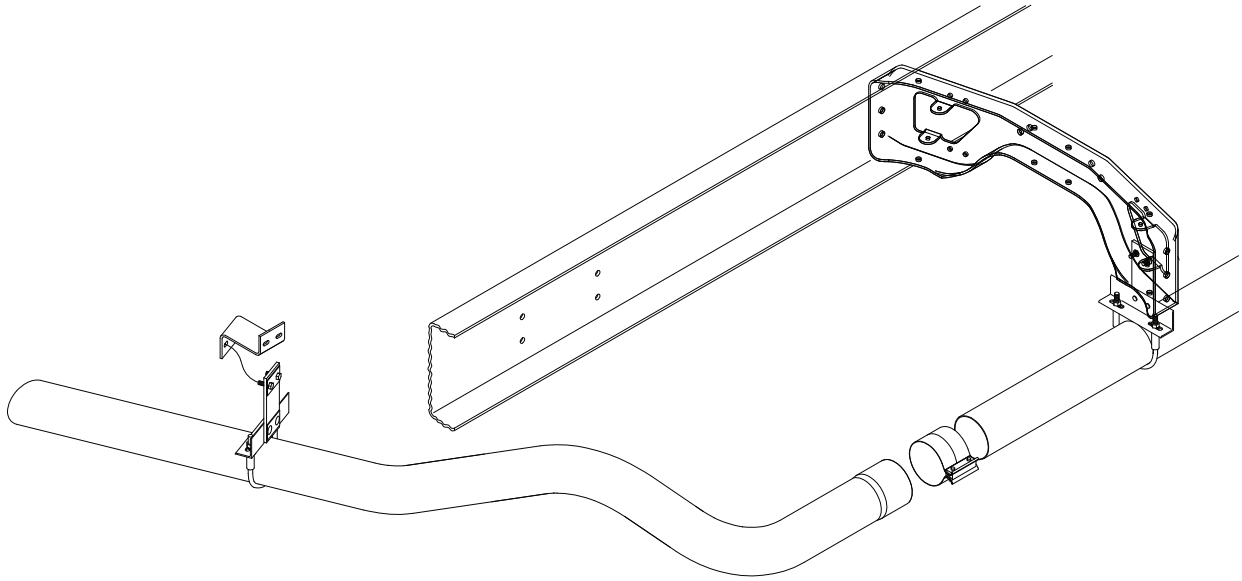

0002632D

Side Exhaust: A3FE

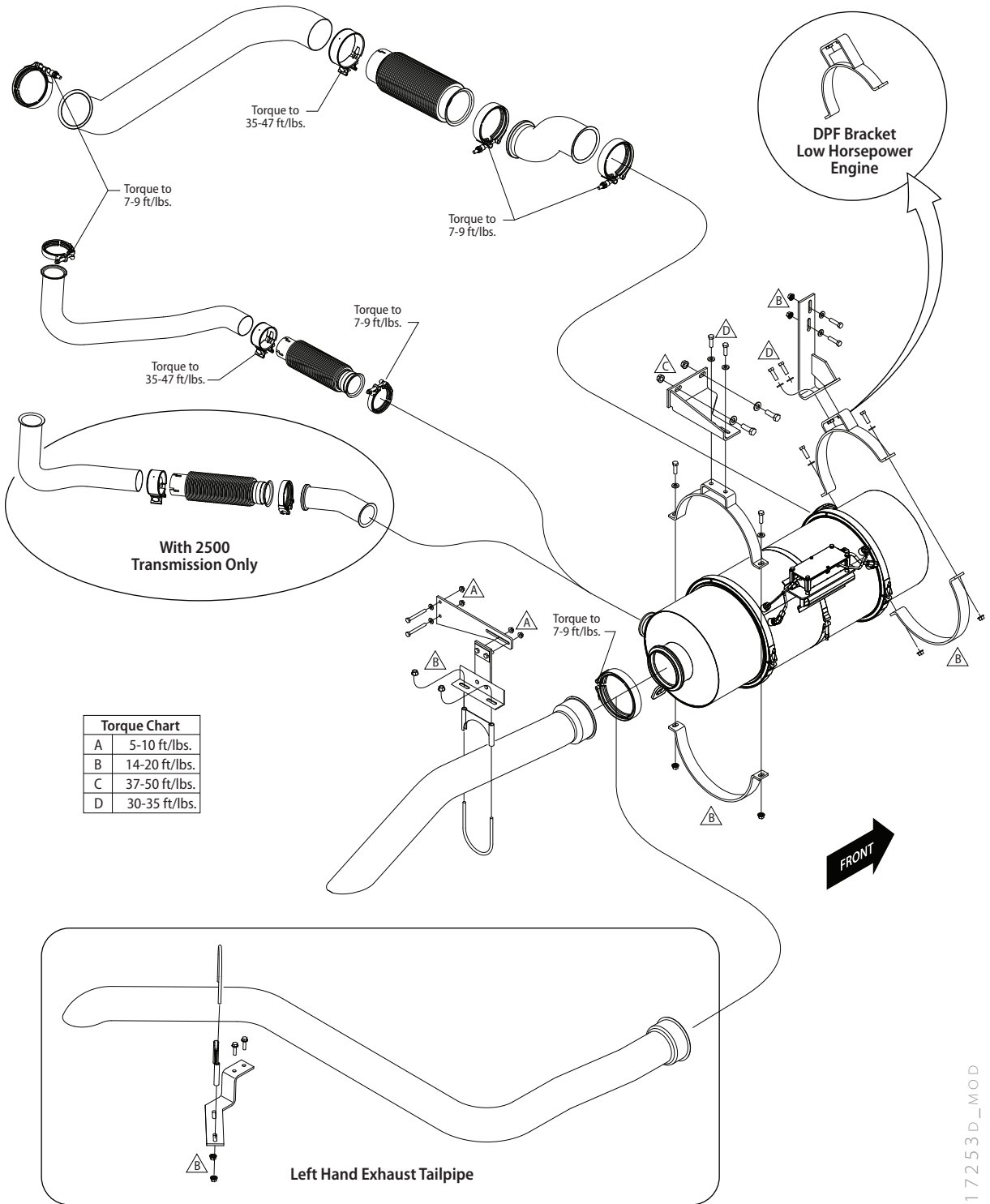

Exhaust: A3RE With Cat C7

0117253D_MOD

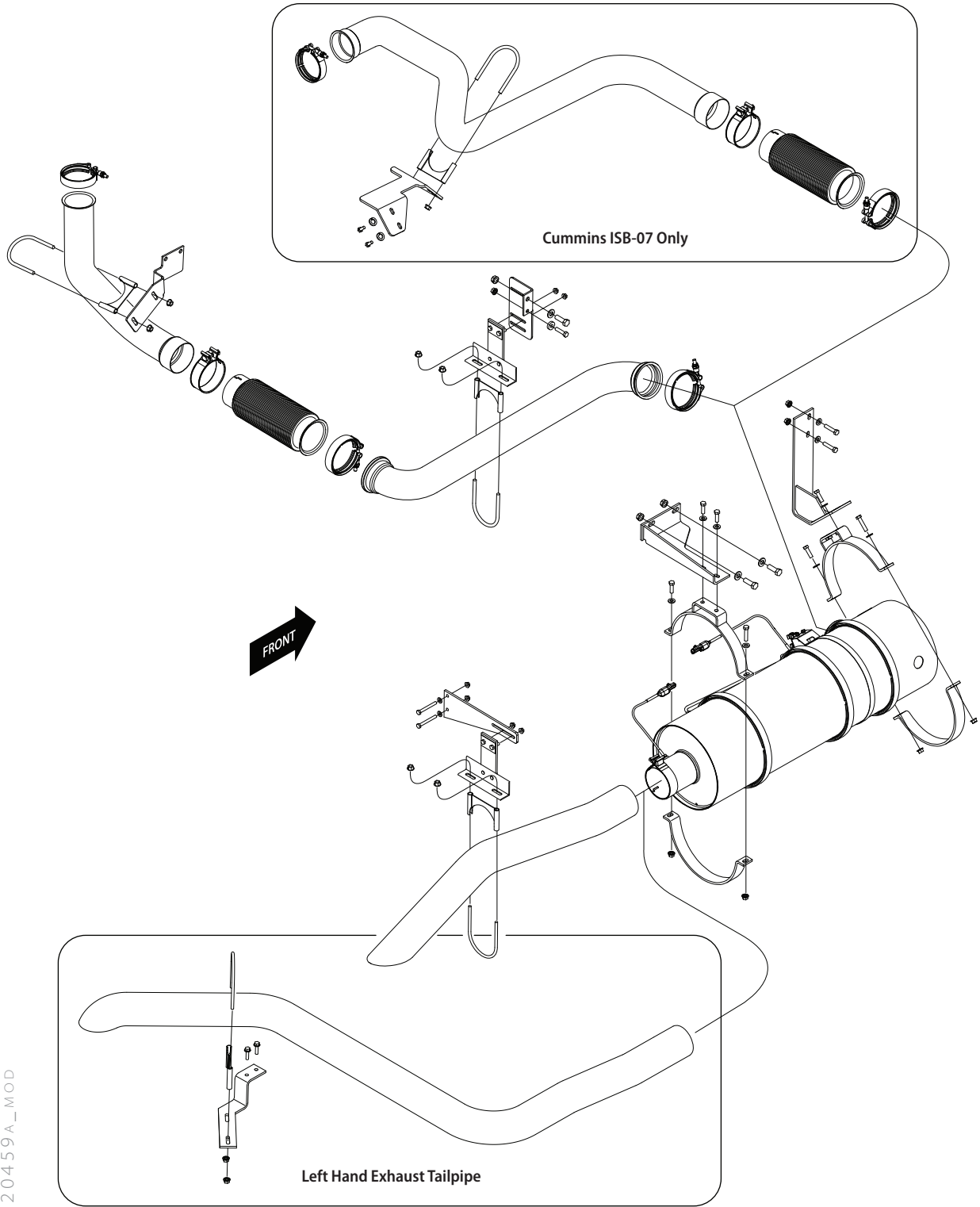

0120459A_MOD

Exhaust: A3RE With Cummins ISC & ISB



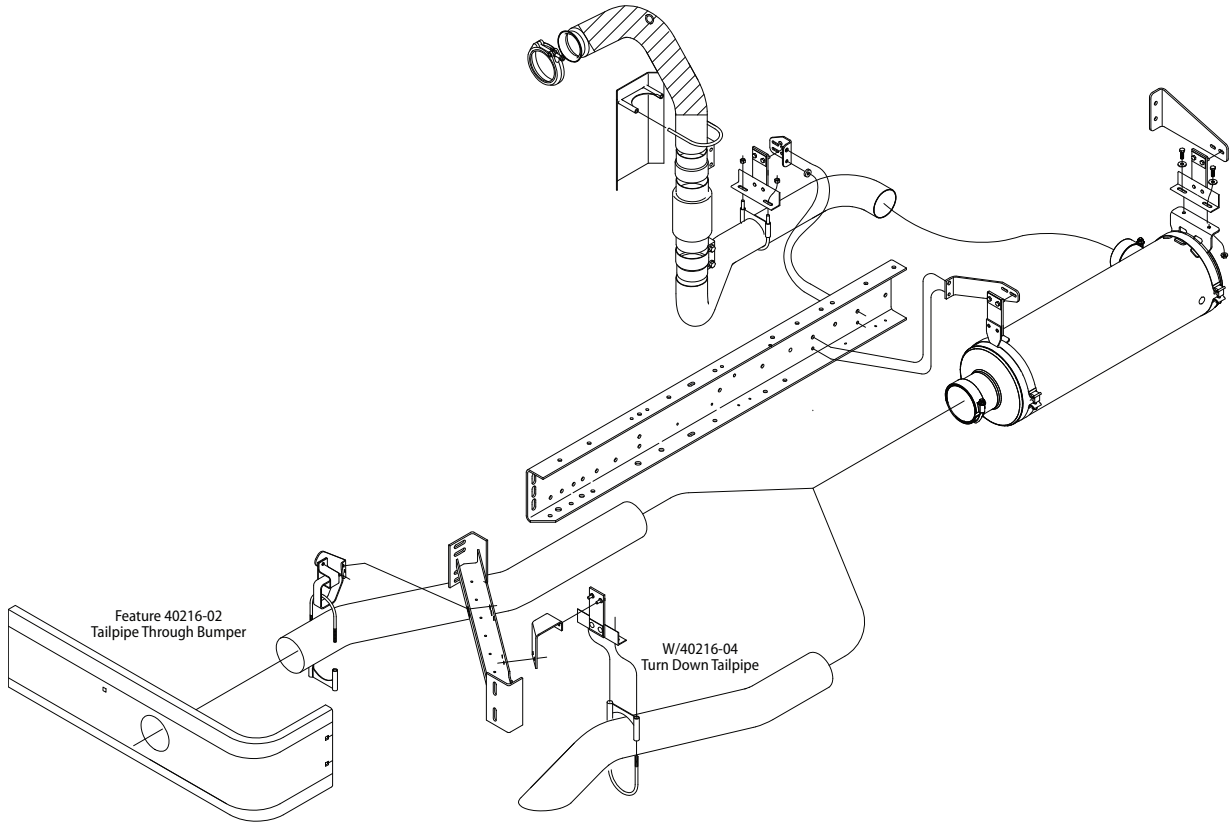

0075175

Exhaust: A3RE With John Deere 8.1