

# Genie®



## Operator's Manual

*with Maintenance Information*

First Edition  
Sixth Printing  
Part No. 72129

### Runabout™

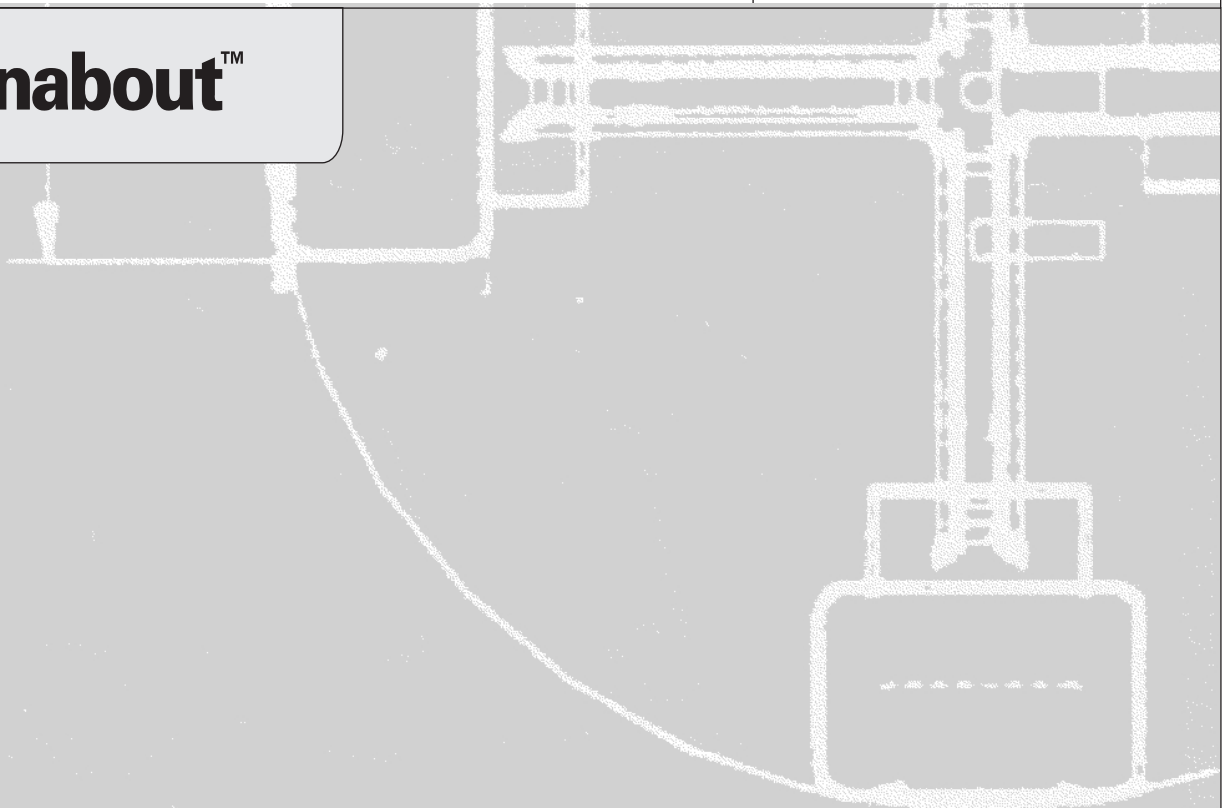

---

## Important

Read, understand and obey these safety rules and operating instructions before operating this machine. Only trained and authorized personnel shall be permitted to operate this machine. This manual should be considered a permanent part of your machine and should remain with the machine at all times. If you have any questions, call Genie Industries.

## Contents

	Page
Safety .....	1
Legend .....	8
Controls .....	9
Pre-operation Inspection .....	11
Maintenance .....	13
Function Tests .....	15
Workplace Inspection .....	21
Operating Instructions .....	22
Transport and Lifting Instructions .....	26
Decals .....	28
Specifications .....	30

## Contact us:

Internet: <http://www.genielift.com>  
 e-mail: [techpub@genieind.com](mailto:techpub@genieind.com)

Copyright © 2000 by Genie Industries

First Edition: Sixth Printing, October 2002

"Genie" is a registered trademark of Genie Industries in the U.S.A. and many other countries. "Runabout" and "GR" are trademarks of Genie Industries.

These machines comply with ANSI/SIA 92.6-1999.

 Printed on recycled paper

Printed in U.S.A.

---

# Safety Rules



---

## Danger

Failure to obey the instructions and safety rules in this manual will result in death or serious injury.

---

## Do Not Operate Unless:

- You learn and practice the principles of safe machine operation contained in this operator's manual.

### 1 Avoid hazardous situations.

**Know and understand the safety rules before going on to the next section.**

2 Always perform a pre-operation inspection.

3 Always perform function tests prior to use.

4 Inspect the workplace.

5 Only use the machine as it was intended.

- You read, understand and obey:

Manufacturer's instructions and safety rules—safety and operator's manuals and machine decals

employer's safety rules and worksite regulations

applicable governmental regulations

- You are properly trained to safely operate the machine.

SAFETY RULES

### Electrocution Hazards

This machine is **not** electrically insulated and will **not** provide protection from contact with or proximity to electrical current.

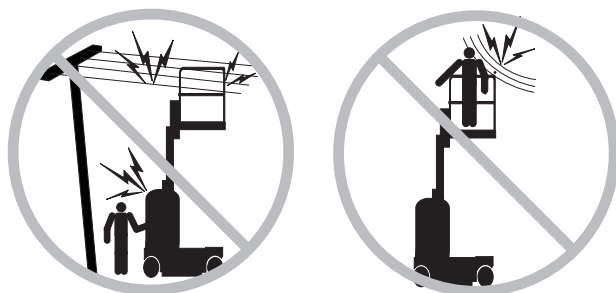

Maintain safe distances from electrical power lines and apparatus in accordance with applicable governmental regulations and the following chart.

Voltage Phase to Phase	Minimum Safe Approach Distance	
	Feet	Meters
0 to 300V	Avoid Contact	
300V to 50KV	10	3.05
50KV to 200KV	15	4.60
200KV to 350KV	20	6.10
350KV to 500KV	25	7.62
500KV to 750KV	35	10.67
750KV to 1000KV	45	13.72

Allow for platform movement, electrical line sway or sag and beware of strong or gusty winds.

Keep away from the machine if it contacts energized power lines. Personnel on the ground or in the platform must not touch or operate the machine until energized power lines are shut off.

Do not operate the machine during lightning or storms.

Do not use the machine as a ground for welding.

### Tip-over Hazards

Occupants and equipment must not exceed the maximum platform capacity or the maximum capacity of the platform extension. Weight in the work station tray is part of the total platform load.

#### Maximum capacity - GR-8 & GR-12

Platform without extension	500 lbs	227 kg
Platform retracted	500 lbs	227 kg
Platform extended - Platform only	250 lbs	113 kg
Platform extended - Extension only	250 lbs	113 kg
Work station tray	50 lbs	22 kg
Fiberglass platform	350 lbs	159 kg
Maximum occupants		1



500 lbs / 227 kg



Extension only  
250 lbs / 113 kg

Platform only  
250 lbs / 113 kg

#### Maximum capacity - GR-15

Platform without extension	350 lbs	159 kg
Platform retracted	350 lbs	159 kg
Platform extended - Platform only	100 lbs	45 kg
Platform extended - Extension only	250 lbs	113 kg
Work station tray	50 lbs	22 kg
Fiberglass platform	350 lb	159 kg
Maximum occupants		1



350 lbs / 159 kg



Extension only  
250 lbs / 113 kg

Platform only  
100 lbs / 45 kg

**SAFETY RULES**

Do not raise the platform unless the machine is on a firm, level surface.

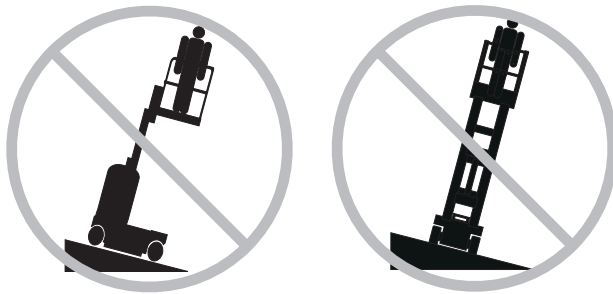

Do not depend on the tilt alarm as a level indicator. The tilt alarm sounds only when the machine is on a slope.

If the tilt alarm sounds:  
Lower the platform immediately. Move the machine to a firm, level surface. If the tilt alarm sounds when the platform is raised, use extreme caution to lower the platform.

Do not alter or disable the limit switches.

Do not drive over 0.5 mph / 0.8 km/h with the platform raised.

Do not operate the machine in strong or gusty winds. Do not increase the surface area of the platform or the load. Increasing the area exposed to the wind will decrease machine stability.

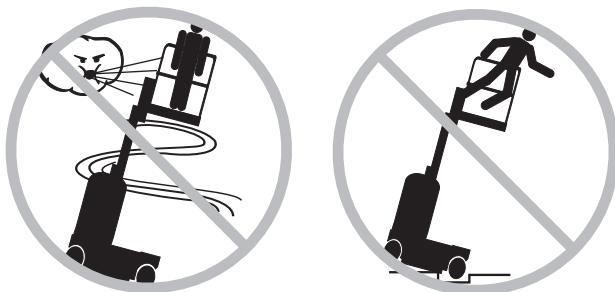

Do not drive the machine on or near uneven terrain, unstable surfaces or other hazardous conditions with the platform raised.

Use extreme care and slow speeds while driving the machine in the stowed position across uneven terrain, debris, unstable or slippery surfaces and near holes and drop-offs.

Do not use the platform controls to free a platform that is caught, snagged or otherwise prevented from normal motion by an adjacent structure. All personnel must be removed from the platform before attempting to free the platform using the ground controls.

Do not push off or pull toward any object outside of the platform.

**Maximum allowable manual force**

ANSI/CSA	100 lbs / 445 N
CE	45 lbs / 200 N



Do not alter or disable machine components that in any way affect safety and stability.

Do not modify or alter an aerial work platform. Mounting attachments for holding tools or other materials onto the platform, toeboards or guard rail system can increase the weight in the platform and the surface area of the platform or the load.

## SAFETY RULES

Do not replace items critical to machine stability with items of different weight or specification.

Do not place or attach fixed or overhanging loads to any part of this machine.

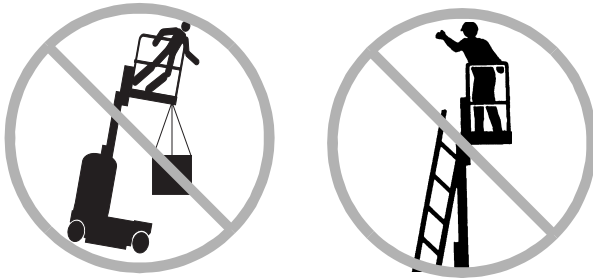

Do not place ladders or scaffolds in the platform or against any part of this machine.

Do not use the machine on a moving or mobile surface or vehicle.

Be sure all tires are in good condition, castle nuts are properly tightened and cotter pins are properly installed.

Do not use batteries that weigh less than the original equipment. Batteries are used as counterweight and are critical to machine stability. Each battery must weigh 62 pounds / 28 kg.

Do not use the machine as a crane.

Do not push the machine or other objects with the platform.

Do not contact adjacent structures with the platform.

Do not tie the platform to adjacent structures.

Do not place loads outside the platform perimeter.

## Fall Hazards



Occupants should wear a safety belt or harness and comply with applicable governmental regulations. Attach lanyard to anchor provided in platform.

Do not sit, stand or climb on the platform guard rails. Maintain a firm footing on the platform floor at all times.



Do not climb down from the platform when raised.

Keep the platform floor clear of debris.

Lower the platform mid-rail bar or close the platform entry gate before operating.

SAFETY RULES

**Collision Hazards**



Be aware of limited sight distance and blind spots when driving or operating.

Be aware of the extended platform position when moving the machine.

It is recommended that operators wear an approved hard hat when operating the machine.

Check the work area for overhead obstructions or other possible hazards.

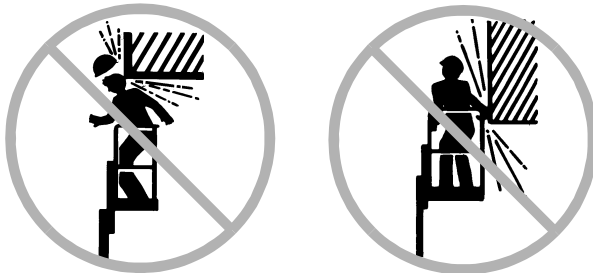

Be aware of crushing hazards when grasping the platform guard rail.

Observe and use the color-coded direction arrows on the platform controls and platform decal plate for drive and steer functions.

No stunt driving or horseplay while operating a machine.

Do not lower the platform unless the area below is clear of personnel and obstructions.

Limit travel speed according to the condition of the ground surface, congestion, slope, location of personnel, and any other factors which may cause collision.

Do not operate a machine in the path of any crane or moving overhead machinery unless the controls of the crane have been locked out and/or precautions have been taken to prevent any potential collision.

**Crushing Hazard**

Use common sense and planning when operating the machine with the controller from the ground. Maintain safe distances between the operator, the machine and fixed objects.

**Component Damage Hazard**

Do not use the machine as a ground for welding.

**Explosion and Fire Hazard**

Do not operate the machine or charge the battery in hazardous locations or locations where potentially flammable or explosive gases or particles may be present.

## SAFETY RULES

## Damaged Machine Hazards

Do not use a damaged or malfunctioning machine.

Conduct a thorough pre-operation inspection of the machine and test all functions before each work shift. Immediately tag and remove from service a damaged or malfunctioning machine.

Be sure all maintenance has been performed as specified in this manual and the appropriate service manual.

Be sure all decals are in place and legible.

Be sure the operator's, safety, and responsibilities manuals are complete, legible and in the storage container located on the platform.

## Bodily Injury Hazard

Do not operate the machine with a hydraulic oil or air leak. An air leak or hydraulic leak can penetrate and/or burn skin.

## Decal Legend

Genie product decals use symbols, color coding and signal words to identify the following:



Safety alert symbol—used to alert personnel to potential personal injury hazards. Obey all safety messages that follow this symbol to avoid possible injury or death.

**▲ DANGER**

Red—used to indicate the presence of an imminently hazardous situation which, if not avoided, will result in death or serious injury.

**▲ WARNING**

Orange—used to indicate the presence of a potentially hazardous situation which, if not avoided, could result in death or serious injury.

**▲ CAUTION**

Yellow with safety alert symbol—used to indicate the presence of a potentially hazardous situation which, if not avoided, may cause minor or moderate injury.

**CAUTION**

Yellow without safety alert symbol—used to indicate the presence of a potentially hazardous situation which, if not avoided, may result in property damage.

**NOTICE**

Green—used to indicate operation or maintenance information.



## SAFETY RULES

## Battery Safety

---

### Burn Hazards

Batteries contain acid. Always wear protective clothing and eyewear when working with batteries.

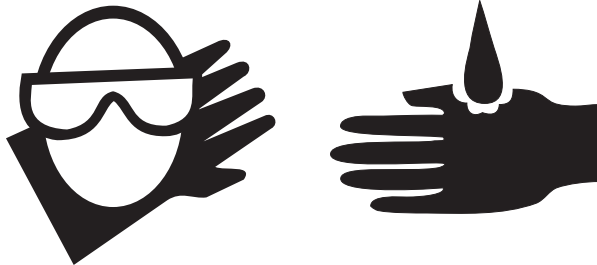

Avoid spilling or contacting battery acid. Neutralize battery acid spills with baking soda and water.

Do not expose the batteries or the charger to water and/or rain during charging.

### Explosion Hazards



Keep sparks, flames and lighted tobacco away from batteries. Batteries emit an explosive gas.

The battery tray should remain open during the entire charging cycle.

Do not contact the battery terminals or the cable clamps with tools that may cause sparks.

### Component Damage Hazard

Do not use any battery charger greater than 24V to charge the batteries.

### Electrocution Hazards



Connect the battery charger to a grounded, AC 3-wire electrical outlet only.

Inspect daily for damaged cord, cables and wires. Replace damaged items before operating.

Avoid electrical shock from contact with battery terminals. Remove all rings, watches and other jewelry.

### Tip-over Hazard

Do not use batteries that weigh less than the original equipment. Batteries are used as counterweight and are critical to machine stability. Each battery must weigh 62 pounds / 28 kg.

### Lifting Hazard

Use the appropriate number of people and proper lifting techniques when lifting batteries.

# Legend

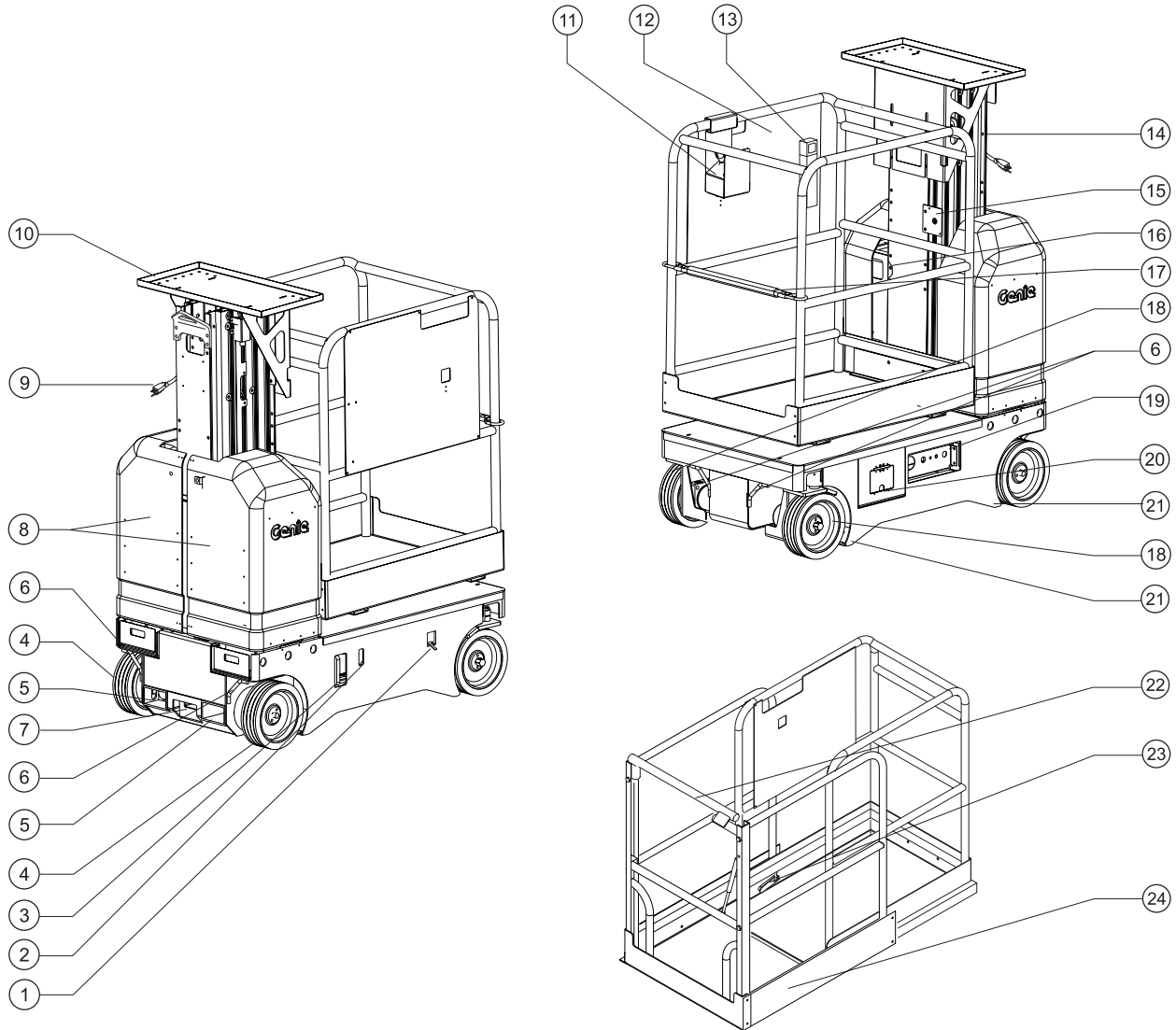

- |  |                             |  |
|--|-----------------------------|--|
| 1 Brake release switch   | 10 Work station tray        | 19 Ground controls   |
| 2 Hydraulic oil level indicator                                      | 11 Platform controls        | 20 Battery charger connection or optional charger/inverter display |
| 3 Battery disconnect   | 12 Decal plate              | 21 Pothole guard (fixed)   |
| 4 Non-steer tire   | 13 Manual storage container | 22 Platform extension entry gate                                   |
| 5 Forklift pocket  | 14 Mast                     | 23 Platform extension release pedal                                |
| 6 Transport tie-down   | 15 GFCI outlet              | 24 Platform extension (option)                                     |
| 7 Manual lowering valve  | 16 Lanyard anchorage        |  |
| 8 Battery covers   | 17 Mid-rail entry bar       |  |
| 9 Power to platform/battery charger connection for optional inverter | 18 Steer tire               |  |

# Controls

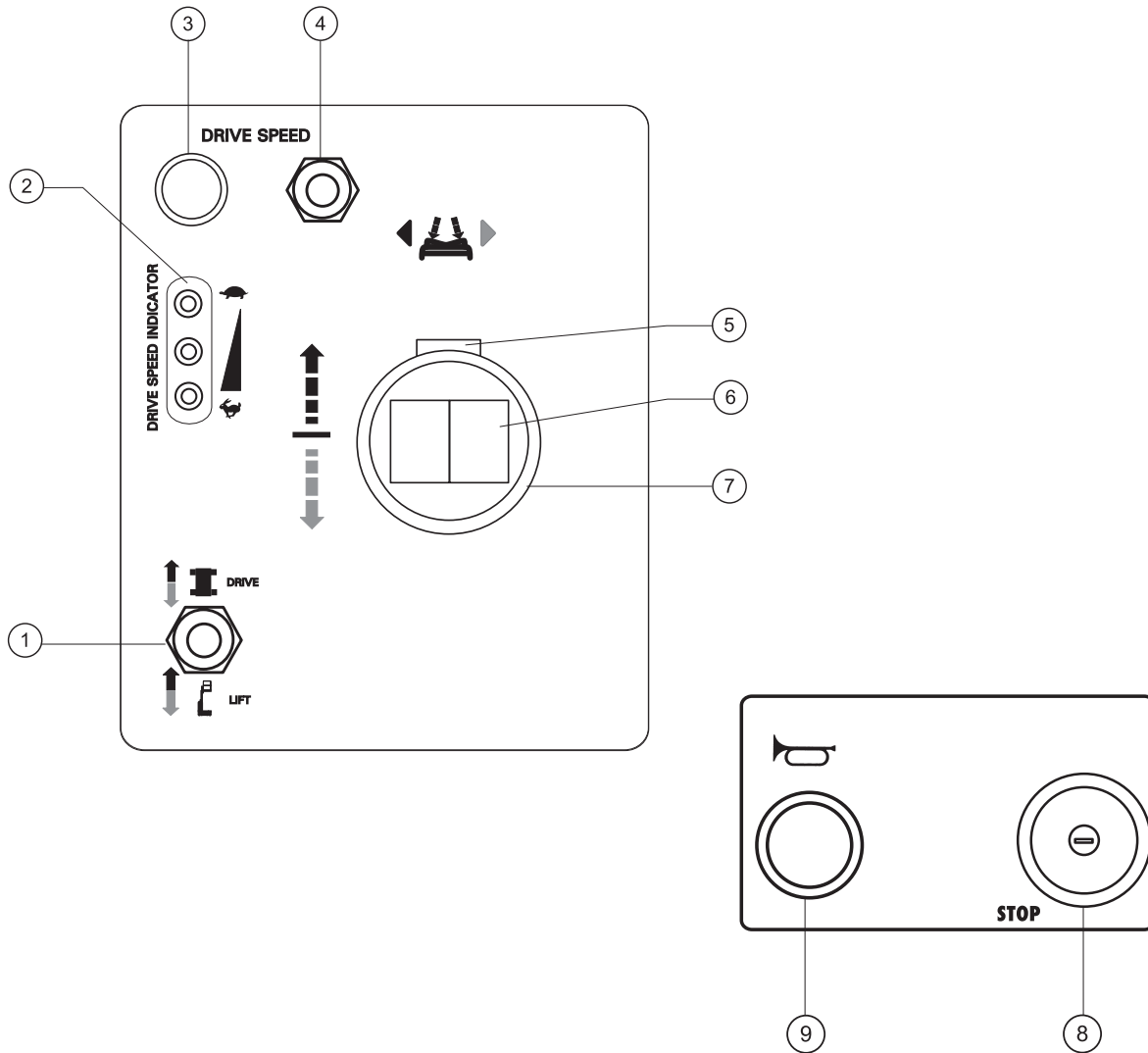

## Joystick Controller

- |  |   |  |
|--|---|--|
| 1 Lift/drive select toggle switch (position may be different on some machines) | 3 Drive speed button (if equipped)        | 6 Thumb rocker for steer function                          |
| 2 Drive speed indicator lights (if equipped)                                   | 4 Drive speed toggle switch (if equipped) | 7 Proportional control handle for lift and drive functions |
|  | 5 Function enable switch                  | 8 Red Emergency Stop button                                |
|  |   | 9 Horn (option)  |

CONTROLS

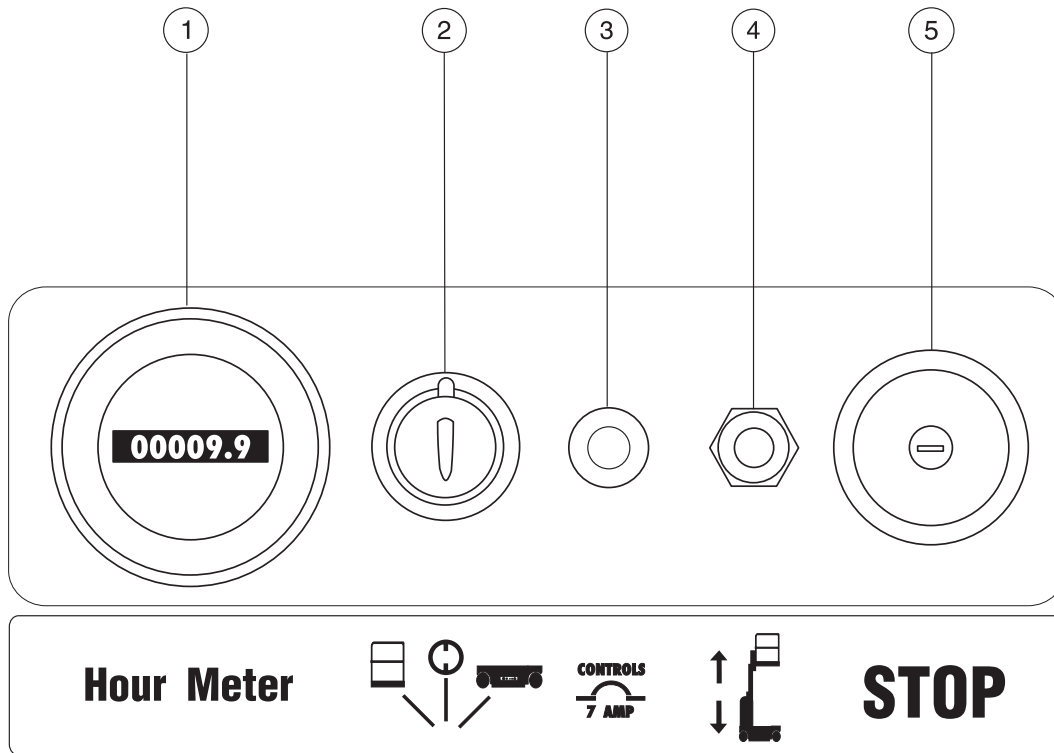

**Ground Control Panel**

- |   |  |   |                                |
|---|--|---|--------------------------------|
| 1 | Hour meter                                   | 4 | Platform up/down toggle switch |
| 2 | Key switch for platform/off/ground selection | 5 | Red Emergency Stop button      |
| 3 | 7 amp breaker for electrical circuits        |   |                                |

# Pre-operation Inspection



---

## Do Not Operate Unless:

- You learn and practice the principles of safe machine operation contained in this operator's manual.

1 Avoid hazardous situations.

**2 Always perform a pre-operation inspection.**

**Know and understand the pre-operation inspection before going on to the next section.**

3 Always perform function tests prior to use.

4 Inspect the workplace.

5 Only use the machine as it was intended.

## Fundamentals

It is the responsibility of the operator to perform a pre-operation inspection and routine maintenance.

The pre-operation inspection is a visual inspection performed by the operator prior to each work shift. The inspection is designed to discover if anything is apparently wrong with a machine before the operator performs the function tests.

The pre-operation inspection also serves to determine if routine maintenance procedures are required. Only routine maintenance items specified in this manual may be performed by the operator.

Refer to the list on the next page and check each of the items and locations for modifications, damage or loose or missing parts.

A damaged or modified machine must never be used. If damage or any variation from factory delivered condition is discovered, the machine must be tagged and removed from service.

Repairs to the machine may only be made by a qualified service technician, according to the manufacturer's specifications. After repairs are completed, the operator must perform a pre-operation inspection again before going on to the function tests.

Scheduled maintenance inspections shall be performed by qualified service technicians, according to the manufacturer's specifications and the requirements listed in the responsibilities manual.

---

## PRE-OPERATION INSPECTION

### Pre-operation Inspection

---

- Be sure that the operator's, safety and responsibilities manuals are complete, legible and in the storage container located on the platform.
- Be sure that all decals are legible and in place. See Decals section.
- Check for hydraulic oil leaks and proper oil level. See Maintenance section.
- Check for battery fluid leaks and proper fluid level. Add distilled water if needed. See Maintenance section.

Check the following components or areas for damage, modifications and improperly installed or missing parts:

- Electrical components, wiring and electrical cables
- Hydraulic power unit, tank, hoses, fittings, cylinders and manifolds
- Battery pack and connections
- Drive motors
- Wear pads
- Tires and wheels
- Limit switches and alarms
- Nuts, bolts and other fasteners
- Platform entry mid-rail bar or gate
- Sequencing cables and pulley
- Platform extension (if equipped)
- Mast columns and counterweight
- Platform control joystick
- Brake release components

Check the entire machine for:

- Cracks in welds or structural components
- Dents or damage to the machine
- Be sure that all structural and other critical components are present and all associated fasteners and pins are in place and properly tightened.

# Maintenance



## Observe and Obey:

- ☑ Only routine maintenance items specified in this manual shall be performed by the operator.
- ☑ Scheduled maintenance inspections shall be completed by qualified service technicians, according to the manufacturer's specifications and the requirements specified in the responsibilities manual.

## Maintenance Symbols Legend

### NOTICE

The following symbols have been used in this manual to help communicate the intent of the instructions. When one or more of the symbols appear at the beginning of a maintenance procedure, it conveys the meaning below.



Indicates that tools will be required to perform this procedure.



Indicates that new parts will be required to perform this procedure.

## Check the Hydraulic Oil Level



Maintaining the hydraulic oil at the proper level is essential to safe machine operation. Improper hydraulic oil levels can damage hydraulic components. Daily checks allow the inspector to identify changes in oil level that might indicate the presence of hydraulic system problems.

- 1 Be sure the platform is fully lowered. Visually inspect the hydraulic oil level through the indicator on the side of the machine.
- ⦿ Result: The hydraulic oil level should be visible.

## MAINTENANCE

## Check the Batteries



Proper battery condition is essential to good engine performance and operational safety. Improper fluid levels or damaged cables and connections can result in component damage and hazardous conditions.

**AWARNING** Electrocutation hazard. Contact with hot or live circuits could result in death or serious injury. Remove all rings, watches and other jewelry.

**AWARNING** Bodily injury hazard. Batteries contain acid. Avoid spilling or contacting battery acid. Neutralize battery acid spills with baking soda and water.

**NOTICE** Perform this test after fully charging the batteries.

- 1 Put on protective clothing and eye wear.
- 2 Be sure that the battery cable connections are tight and free of corrosion.
- 3 Remove the battery vent caps.
- 4 Check the battery acid level. If needed, replenish with distilled water to the bottom of the battery fill tube. Do not overfill.
- 5 Install the vent caps.

## Scheduled Maintenance

Maintenance performed quarterly, annually and every two years must be completed by a person trained and qualified to perform maintenance on this machine according to the procedures found in the service manual for this machine.

Machines that have been out of service for more than three months must receive the quarterly inspection before they are put back into service.



# Function Tests



---

## Do Not Operate Unless:

- You learn and practice the principles of safe machine operation contained in this operator's manual.

- 1 Avoid hazardous situations.
- 2 Always perform a pre-operation inspection.

### **3 Always perform function tests prior to use.**

### **Know and understand the function tests before going on to the next section.**

- 4 Inspect the workplace.
- 5 Only use the machine as it was intended.

## Fundamentals

The function tests are designed to discover any malfunctions before the machine is put into service. The operator must follow the step-by-step instructions to test all machine functions.

A malfunctioning machine must never be used. If malfunctions are discovered, the machine must be tagged and removed from service. Repairs to the machine may only be made by a qualified service technician, according to the manufacturer's specifications.

After repairs are completed, the operator must perform a pre-operation inspection and function tests again before putting the machine into service.

## FUNCTION TESTS

- 1 Select a test area that is firm, level and free of obstruction.
- 2 Be sure the battery pack is connected.

**At the Ground Controls**

- 3 Pull out the platform and ground red Emergency Stop buttons to the on position.
- 4 Turn the key switch to ground control.

**Test Emergency Stop**

- 5 Push in the ground red Emergency Stop button to the off position.
- ⦿ Result: No functions should operate.
- 6 Pull out the red Emergency Stop button to the on position.

**Test the Up/Down Functions**

- 7 Activate the up function.
- ⦿ Result: The platform should raise.
- 8 Activate the down function.
- ⦿ Result: The platform should lower. The descent alarm should sound while the platform is lowering.

**Test Manual Lowering**

- 9 Activate the up function and raise the platform approximately 2 feet / 60 cm.
  - 10 Pull the manual lowering knob located at the back of the machine.
- ⦿ Result: The platform should lower. The descent alarm will not sound.
- 11 Turn the key switch to platform control.

**At the Platform Controls****Test Emergency Stop**

- 12 Push in the platform red Emergency Stop button to the off position.

- ⦿ Result: No functions should operate.

**Test the Horn (if equipped)**

- 13 Pull out the red Emergency Stop button to the on position.

- 14 Push the horn button.

- ⦿ Result: The horn should sound.

**Test the Function Enable Switch**

- 15 Do not hold the function enable switch on the control handle.
- 16 Slowly move the control handle in the direction indicated by the blue arrow, then in the direction indicated by the yellow arrow.

- ⦿ Result: No functions should operate.

**Test the Up/Down Functions**

- 17 Move the lift/drive select switch to the lift position.
  - 18 Press and hold the function enable switch on the control handle.
  - 19 Slowly move the control handle in the direction indicated by the blue arrow.
- ⦿ Result: The platform should raise.
- 20 Release the control handle.
- ⦿ Result: The platform should stop raising.
- 21 Press and hold the function enable switch. Slowly move the control handle in the direction indicated by the yellow arrow.
- ⦿ Result: The platform should lower. The descent alarm should sound while the platform is lowering.

## FUNCTION TESTS

**Test the Steering**

Note: When performing the steer and drive function tests, stand in the platform facing the steer end of the machine.

- 22 Move the lift/drive select switch to the drive position.
- 23 Press and hold the function enable switch on the control handle.
- 24 Press the thumb rocker switch on top of the control handle in the direction indicated by the blue triangle on the control panel.
  - ⦿ Result: The steer wheels should turn in the direction that the blue triangle points on the control panel.
- 25 Press the thumb rocker switch in the direction indicated by the yellow triangle on the control panel.
  - ⦿ Result: The steer wheels should turn in the direction that the yellow triangle points on the control panel.

**Test Drive and Braking**

- 26 Press and hold the function enable switch on the control handle.
- 27 Slowly move the control handle in the direction indicated by the blue arrow on the control panel until the machine begins to move, then return the handle to the center position.
  - ⦿ Result: The machine should move in the direction that the blue arrow points on the control panel, then come to an abrupt stop.
- 28 Slowly move the control handle in the direction indicated by the yellow arrow on the control panel until the machine begins to move, then return the handle to the center position.
  - ⦿ Result: The machine should move in the direction that the yellow arrow points on the control panel, then come to an abrupt stop.

Note: The brakes must be able to hold the machine on any slope it is able to climb.

## FUNCTION TESTS

**Test the Tilt Sensor Operation**

Note: Perform this test from the ground with the platform controller. Do not stand in the platform.

- 29 Move the lift/drive select switch to the lift position.
- 30 Fully lower the platform.
- 31 Place a 2x4 or similar piece of wood in front of each wheel on one side of the machine.
- 32 Move the lift/drive select switch to the drive position.
- 33 Drive the machine up onto both pieces of wood.

**Machines before serial number 1800:**

- ⦿ Result: An alarm should sound.
- 34 Drive the machine off both pieces of wood.

Note: On CE models, the lift function will not operate when the tilt alarm sounds.

Proceed to step 40.

**Machines after serial number 1799:**

- ⦿ Result: An alarm should sound.
- 35 Move the lift/drive select switch to the lift position.

- 36 Raise the platform.
  - ⦿ Result: Before the platform is raised approximately 1 foot / 30 cm, the lift function will stop.
- 37 Move the lift/drive select switch to the drive position.
- 38 Press and hold the function enable switch and slowly move the control handle in the direction indicated by the blue arrow, then in the direction indicated by the yellow arrow.
  - ⦿ Result: The drive function should not work in either direction.
- 39 Lower the platform and drive the machine off both pieces of wood.

## FUNCTION TESTS

**Test Limited Drive Speed**

- 40 Move the lift/drive select switch to the lift position.
- 41 Press and hold the function enable switch. Raise the platform approximately 2 feet / 60 cm from the ground.
- 42 Move the lift/drive selector switch to the drive position.
- 43 Press and hold the function enable switch. Slowly move the control handle to the full drive position.
- ⦿ Result: The maximum achievable drive speed with the platform raised should not exceed 0.7 feet / 20 cm per second.

If the drive speed with the platform raised exceeds 0.7 feet / 20 cm per second, immediately tag and remove the machine from service.

- 44 Press the drive speed switch or the drive speed button until one of the drive speed indicator lights turns off.
- 45 Press and hold the function enable switch. Slowly move the control handle to the full drive position.
- ⦿ Result: The maximum achievable drive speed with the platform raised should be approximately 0.4 feet / 10 cm per second.
- 46 Press the drive speed switch or the drive speed button again until two of the drive speed indicator lights are off.
- 47 Press and hold the function enable switch. Slowly move the control handle to the full drive position.
- ⦿ Result: The maximum achievable drive speed with the platform raised should be approximately 0.2 feet / 6 cm meters per second.

## FUNCTION TESTS

**Test the Platform Extension Limit Switch  
(if equipped)**

Note: This test is only required on GR-15 models with an optional platform extension.

Note: Some GR-15 models are equipped to drive at up to 12 feet / 3.6 m with the platform extended. These models have a limit switch on the back of the platform next to the mast. Before performing this test, determine if your machine is equipped with this limit switch.

**Models with limit switch:** Perform this test with the platform raised approximately 13 feet / 3.9 m.

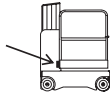

**Models without limit switch:** Perform this test with the platform fully lowered.



- 48 Move the lift/drive select switch to the lift position.
  - 49 Fully lower the platform OR raise the platform to approximately 13 feet / 3.9 m.
  - 50 Step on the platform extension release pedal and extend the platform.
  - 51 Move the lift/drive select switch to the drive position.
  - 52 Slowly move the control handle to the full drive position.
- ⦿ Result: The drive function should not operate.

# Workplace Inspection



---

## Do Not Operate Unless:

- You learn and practice the principles of safe machine operation contained in this operator's manual.

- 1 Avoid hazardous situations.
- 2 Always perform a pre-operation inspection.
- 3 Always perform function tests prior to use.

### 4 Inspect the workplace.

**Know and understand the workplace inspection before going on to the next section.**

- 5 Only use the machine as it was intended.

## Fundamentals

The workplace inspection helps the operator determine if the workplace is suitable for safe machine operation. It should be performed by the operator prior to moving the machine to the workplace.

It is the operator's responsibility to read and remember the workplace hazards, then watch for and avoid them while moving, setting up and operating the machine.

## Workplace Inspection

Be aware of and avoid the following hazardous situations:

- drop-offs or holes
- bumps, floor obstructions or debris
- overhead obstructions and high voltage conductors
- hazardous locations
- inadequate surface support to withstand all load forces imposed by the machine
- wind and weather conditions
- the presence of unauthorized personnel
- other possible unsafe conditions

---

# Operating Instructions



---

## Do Not Operate Unless:

- You learn and practice the principles of safe machine operation contained in this operator's manual.
  - 1 Avoid hazardous situations.
  - 2 Always perform a pre-operation inspection.
  - 3 Always perform function tests prior to use.
  - 4 Inspect the workplace.
  - 5 **Only use the machine as it was intended.**

## Fundamentals

The Operating Instructions section provides instructions for each aspect of machine operation. It is the operator's responsibility to follow all the safety rules and instructions in the operator's, safety and responsibilities manuals.

Using the machine for anything other than lifting personnel and tools to an aerial work site is unsafe and dangerous.

Only trained and authorized personnel should be permitted to operate a machine. If more than one operator is expected to use a machine at different times in the same work shift, they must all be qualified operators and are all expected to follow all safety rules and instructions in the operator's, safety and responsibilities manuals. That means every new operator should perform a pre-operation inspection, function tests, and a workplace inspection before using the machine.



## OPERATING INSTRUCTIONS

## Emergency Stop

Push in the red Emergency Stop button to the off position at the ground or platform controls to stop all machine functions.

Repair any function that operates when either Emergency Stop button is pushed in.

## Operation From Ground

- 1 Turn the key switch to ground control.
- 2 Pull out both ground and platform red Emergency Stop buttons to the on position.
- 3 Be sure the battery pack is connected before operating the machine.

### To Position Platform

- 1 Move the up/down toggle switch according to the markings on the control panel.

Drive and steer functions are not available from the ground controls.

## Operation From Platform

- 1 Turn the key switch to platform control.
- 2 Pull out the ground and platform red Emergency Stop buttons to the on position.
- 3 Be sure the battery pack is connected before operating the machine.

### To Position Platform

- 1 Move the lift/drive select switch to the lift position.
- 2 Press and hold the function enable switch on the control handle.
- 3 Move the control handle according to the markings on the control panel.

### To Steer

- 1 Move the lift/drive select switch to the drive position.
- 2 Press and hold the function enable switch on the control handle.
- 3 Turn the steer wheels with the thumb rocker switch located on the top of the control handle.

### To Drive

- 1 Move the lift/drive select switch to the drive position.
- 2 Press and hold the function enable switch on the control handle.
- 3 Increase speed: Slowly move the control handle off center.

Decrease speed: Slowly move the control handle toward center.

Stop: Return the control handle to center or release the function enable switch.

Use the color-coded direction arrows on the platform controls and on the platform to identify the direction the machine will travel.

Machine travel speed is restricted when the platform is raised.

### To Reduce Drive Speed

The drive controls can operate in three different drive speed modes. When all three lights on the platform control panel are on, the machine is in normal (fastest) drive speed mode. When one light is on, the machine will travel in its slowest drive speed mode.

Press the drive speed switch or push the drive speed button to select the desired drive speed.

---

## OPERATING INSTRUCTIONS

### **To Extend and Retract Platform (if equipped)**

- 1 Step on the platform extension release pedal.
- 2 Grasp the platform guard rails carefully and push to extend the platform.
- 3 Step on the platform extension release pedal and pull the guard rails to retract the platform.

### **Operation From Ground with Controller**

Maintain safe distances between the operator, machine and fixed objects.

Be aware of the direction the machine will travel when using the controller.

### **After Each Use**

- 1 Select a safe parking location—firm level surface, clear of obstruction and traffic.
- 2 Lower the platform.
- 3 Turn the key switch to the off position and remove the key to secure from unauthorized use.
- 4 Chock the wheels.
- 5 Charge the batteries.

### **Inverter Instructions (if equipped)**

The inverter will provide power to the platform when external AC power is removed.

To use the inverter:

- 1 Turn the key switch to platform control.
- 2 Pull out both ground and platform red Emergency Stop buttons to the on position.

The battery charger and external power to platform will function with the key switch in any position.

## OPERATING INSTRUCTIONS



## Battery and Charger Instructions

### Observe and Obey:

- Do not use an external charger or booster battery.
- Charge the battery in a well-ventilated area.
- Use proper AC input voltage for charging as indicated on the machine.
- Use only a Genie authorized battery and charger.

### Dry Battery Filling and Charging Instructions

- 1 Remove the battery vent caps and permanently remove the plastic seal from the battery vent openings.
- 2 Fill each cell with battery acid (electrolyte) until the level is sufficient to cover the plates.

Do not fill to the maximum level until the battery charge cycle is complete. Overfilling can cause the battery acid to overflow during charging. Neutralize battery acid spills with baking soda and water.

- 3 Install the battery vent caps.
- 4 Charge the battery.
- 5 Check the battery acid level when the charging cycle is complete. Replenish with distilled water to the bottom of the fill tube. Do not overfill.

### To Charge Battery

- 1 Be sure the batteries are connected before charging the batteries.
- 2 Open the battery compartment. The compartment should remain open for the entire charging cycle.
- 3 Remove the battery vent caps and check the battery acid level. If necessary, add only enough distilled water to cover the plates. Do not overfill prior to the charge cycle.
- 4 Replace the battery vent caps.
- 5 Connect the battery charger to a grounded AC circuit.

Note: For optional charger/inverter, connect AC power to the plug on the back of the machine.

- 6 Turn the battery charger on (standard charger only).
- 7 The charger will indicate when the battery is fully charged.
- 8 Check the battery acid level when the charging cycle is complete. Replenish with distilled water to the bottom of the fill tube. Do not overfill.

# Transport and Lifting Instructions



## Observe and Obey:

- ☑ Common sense and planning must be applied to control the movement of the machine when lifting it with a crane or forklift.
- ☑ The transport vehicle must be parked on a level surface.
- ☑ The transport vehicle must be secured to prevent rolling while the machine is being loaded.
- ☑ Be sure the vehicle capacity, loading surfaces and chains or straps are sufficient to withstand the machine weight. See the serial plate for the machine weight.
- ☑ The machine must be on a level surface or secured before releasing the brakes.

## Brake Release Operation (if equipped)

- 1 Chock the wheels to prevent the machine from rolling.
- 2 Be sure the winch line is properly secured to the drive chassis tie points and the path is clear of all obstructions.
- 3 Pull the brake release switch to open the brake valve.
- 3 Turn the key switch to platform control.
- 4 Pull out both ground and platform red Emergency Stop buttons to the on position.
- 4 Move the lift/drive selector switch on the platform control panel to the drive position.
- 5 Hold the function enable switch and move the control handle into the drive position to release the brakes.

After the machine is loaded:

- 1 Push in both ground and platform red Emergency Stop buttons to the off position.
- 2 Turn the key switch to the off position.
- 3 Chock the wheels to prevent the machine from rolling.
- 4 Push the brake release switch closed to reset the brakes.

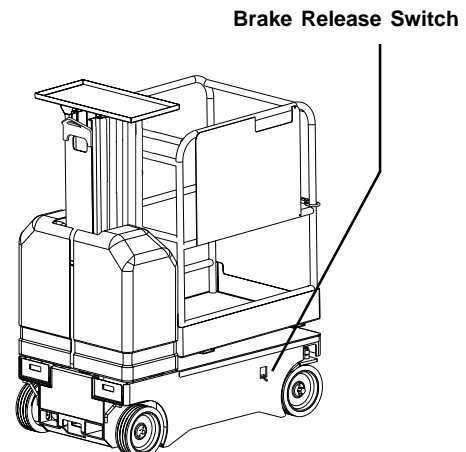

## TRANSPORT AND LIFTING INSTRUCTIONS

## Loading the Machine With a Crane

Use the lifting eye mounted on the rear mast column.

Make sure the mast is fully lowered.

Inspect the machine and remove any loose or unsecured items.

Always place the lifting hook through the lifting eye so that it points away from the machine.



## Securing to Truck or Trailer for Transit

Always chock the machine wheels in preparation for transport.

Turn the key switch to the off position and remove the key before transporting.

Inspect the entire machine for loose or unsecured items.

### Securing the Chassis

Use the tie points on the chassis for anchoring down to the transport surface.

Use chains or straps of ample load capacity.

Use a minimum of 4 chains.

Adjust the rigging to prevent damage to the chains.

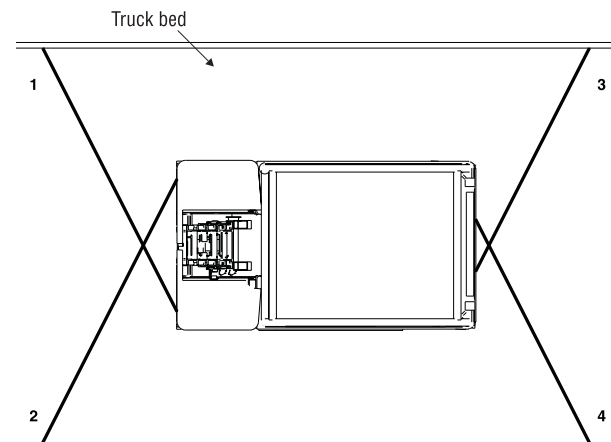

# Decals

## Decal Inspection

Use the pictures on the next page to verify that all decals are legible and in place.

Below is a numerical list with quantities and descriptions.

Part No.	Description	Quantity
28157	Label - Dexron	1
28161	Warning - Crushing Hazard	1
28164	Notice - Hazardous Materials	1
28171	Label - No Smoking	1
28174	Label - Power to Platform, 230V	2
28175	Caution - Compartment Access	1
28235	Label - Power to Platform, 115V	2
28373	Label - Forklift Pocket	2
31060	Danger - Do Not Alter Limit Switch (GR-15 models with extension deck)	1
31071	Warning - Failure to Read Manual	1
31077	Caution - Collision Hazard	1
31508	Notice - Power to Battery Charger	1
37145	Label - Manual Lowering	1
38122	Label - Manual Storage Container	1
38149	Label - Patents	1
40434	Label - Lanyard Anchorage	1
43658	Label - Power to Charger, 230V	1
44736	Danger - Tilt Alarm	1
44980	Label - Power to Charger, 115V	1
46262	Danger - Battery/Charger Safety	1
72086	Label - Lifting Eye	1
72134	Platform Control Panel (Joystick Controller)	1
72135	Ground Control Panel	1
72139	Notice - Operating Instructions - Platform	1

Part No.	Description	Quantity
72140	Notice - Operating Instructions - Ground	1
72141	Danger - General Safety Rules	1
72142	Danger - Electrocutation Hazard	1
72143	Label - Emergency Stop	2
72153	Notice - Max Capacity 500 lbs / 227 kg	1
72155	Notice - Max Capacity 350 lbs / 159 kg	1
72156	Notice - Tire Specifications	4
72158	Notice - Battery Connection Diagram	1
72159	Danger - Tip-over (Batteries)	1
72171	Notice - Max Side Force 100 lbs / 445 N, ANSI & CSA	1
72182	Notice - Side Force/Wind Speed, CE	1
72184	Cosmetic - Genie Runabout	2
72188	Label - Directional Arrows	2
72194	Cosmetic - Genie GR-8	1
72195	Cosmetic - Genie GR-12	1
72196	Cosmetic - Genie GR-15	1
72198	Cosmetic - Genie GR-8 (front)	1
72199	Cosmetic - Genie GR-12 (front)	1
72440	Cosmetic - Genie GR-15 (front)	1
72466	Platform Control Panel (Emergency Stop Button)	1
72832	Danger - Do Not Alter Limit Switch (1 extra on GR-15 models with extension deck)	1
72849	Danger - Brake Release Instructions	1
72850	Notice - Work Tray Capacity	1
72873	Platform Control Panel (Joystick Controller)	1
72892	Label - Brake Release Switch	1
82366	Label - Chevron Rykon	1

DECALS

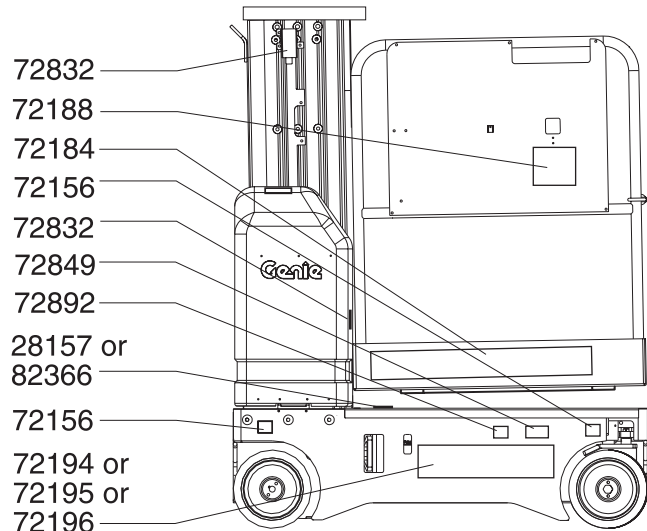

■ Shading indicates decal is hidden from view, i.e., under covers.

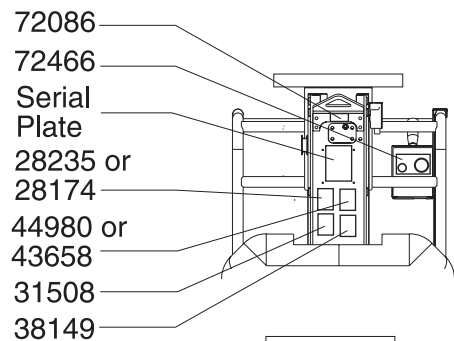
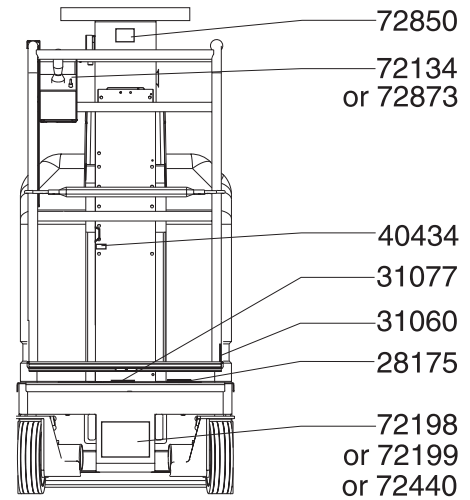

Models with optional inverter

Note: Platform decals may be in different locations on optional fiberglass platform.

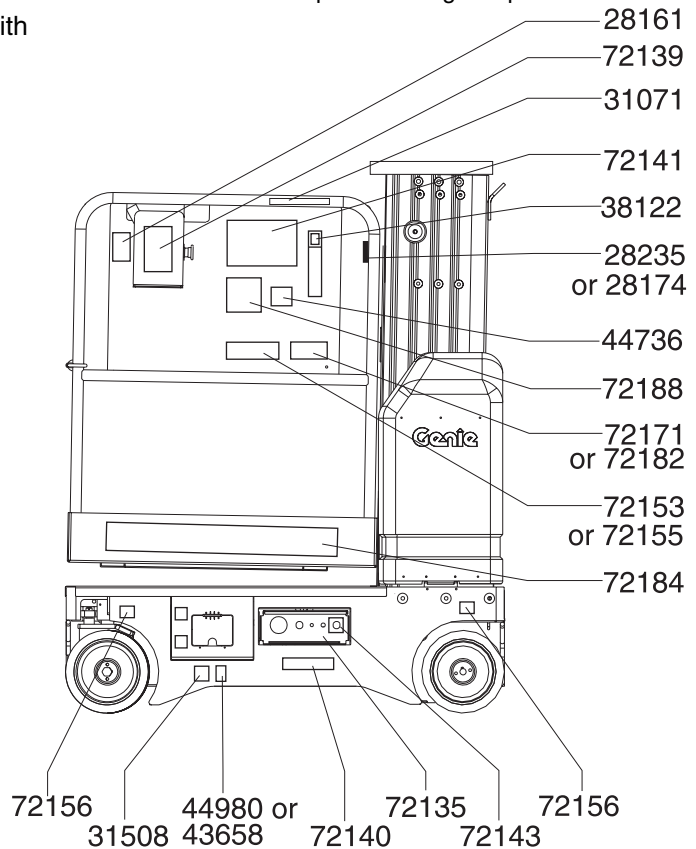
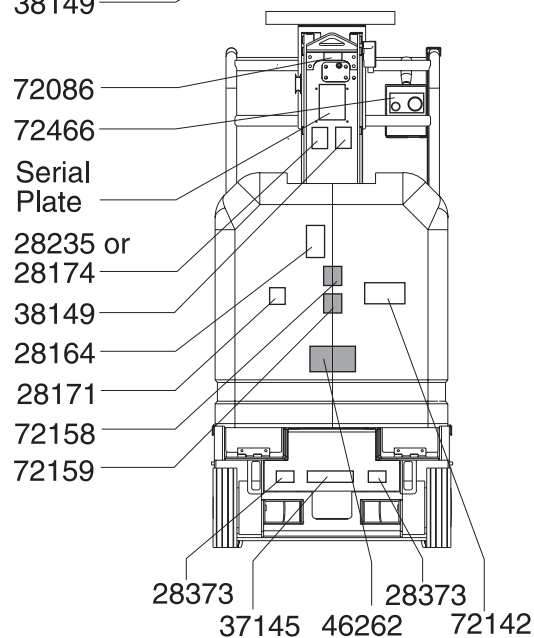

# Specifications

## GR-8

Height, working maximum	14 ft 4 in	4.37 m
Height, platform maximum	8 ft 4 in	2.54 m
Height, stowed maximum including work station tray, ANSI & CSA	68 in	1.73 m
Height, stowed maximum including work station tray, CE	72.5 in	1.84 m
Width	29.5 in	75 cm
Length, stowed	53 in	1.35 m
Length, platform extended	73 in	1.85 m
Maximum load capacity	500 lbs	227 kg
Maximum load capacity, fiberglass platform	350 lbs	159 kg
Turning radius (inside)	6 in	15 cm
Turning radius (outside)	62 in	1.57 m
Weight (Machine weights vary with option configurations)	See Serial Plate	
Gradeability	25%	
Power source	4 Batteries, 6V 225AH	
Controls	Proportional	
Platform dimensions, standard (length x width)	37 in x 29.5 in 94 cm x 75 cm	
Platform dimensions, platform with extension (length x width)	57 in x 29.5 in 1.45 m x 75 cm	
Fiberglass platform	26 x 22 x 43 <sup>1</sup> / <sub>2</sub> in 66 cm x 56 cm x 1.1 m	
AC outlet in platform	standard	
Tire size	10 x 3 x 1 in 25.4 x 7.6 x 2.5 cm	

Standard charger, Domestic	115V AC/60 HZ, 25 amp, 24V DC
----------------------------	-------------------------------

Standard charger, World wide	115V AC/60 HZ, 25 amp, 24V DC OR 230 V AC/50 HZ, 25 amp, 24V DC
------------------------------	--

Standard charger, Europe	230 V AC/50 HZ, 25 amp, 24V DC
--------------------------	--------------------------------

Optional charger/inverter, Domestic	115V AC/60 HZ, 25 amp, 24V DC 1000 Watts
-------------------------------------	---

Optional charger/inverter, World wide	230V AC/50 HZ, 25 amp, 24V DC 1000 Watts
---------------------------------------	---

Airborne noise emissions Maximum sound level at normal operating workstations (A-weighted)	70 dB
---	-------

### Drive speeds

Stowed, maximum	2.5 mph	4.0 km/h
Platform raised, maximum	0.5 mph 40 ft/55 sec	0.8 km/h 12.5 m/55 se

### Floor Loading Information

GVW + Rated Load	1950 lbs	885 kg
Axle load, maximum	1181 lbs	536 kg
Wheel load, maximum	617 lbs	280 kg

Note: Floor loading information is approximate and does not incorporate different option configurations. It should be used only with adequate safety factors.

Continuous improvement of our products is a Genie policy. Product specifications are subject to change without notice or obligation.



SPECIFICATIONS

<b>GR-12</b>		
Height, working maximum	17 ft 9 in	5.41 m
Height, platform maximum	11 ft 9 in	3.58 m
Height, stowed maximum including work station tray, ANSI & CSA	68 in	1.73 m
Height, stowed maximum including work station tray, CE	72.5 in	1.84 m
Width	29.5 in	75 cm
Length, stowed	53 in	1.35m
Length, platform extended	73 in	1.85 m
Maximum load capacity	500 lbs	227 kg
Maximum load capacity, fiberglass platform	350 lbs	159 kg
Turning radius (inside)	6 in	15 cm
Turning radius (outside)	62 in	1.57 m
Weight (Machine weights vary with option configurations)	See Serial Plate	
Gradeability	25%	
Power source	4 Batteries, 6V 225AH	
Controls	Proportional	
Platform dimensions, standard (length x width)	37 in x 29.5 in 94 cm x 75 cm	
Platform dimensions, platform with extension (length x width)	57 in x 29.5 in 1.45 m x 75 cm	
Fiberglass platform	26 x 22 x 43 <sup>1</sup> / <sub>2</sub> in 66 cm x 56 cm x 1.1 m	
AC outlet in platform	standard	
Tire size	10 x 3 x 1 in 25.4 x 7.6 x 2.5 cm	

Standard charger, Domestic	115V AC/60 HZ, 25 amp, 24V DC	
Standard charger, World wide	115V AC/60 HZ, 25 amp, 24V DC OR 230 V AC/50 HZ, 25 amp, 24V DC	
Standard charger, Europe	230 V AC/50 HZ, 25 amp, 24V DC	
Optional charger/inverter, Domestic	115V AC/60 HZ, 25 amp, 24V DC 1000 Watts	
Optional charger/inverter, World wide	230V AC/50 HZ, 25 amp, 24V DC 1000 Watts	
Airborne noise emissions	70 dB	
Maximum sound level at normal operating workstations (A-weighted)		

**Drive speeds**

Stowed, maximum	2.5 mph	4.0 km/h
Platform raised, maximum	0.5 mph 40 ft/55 sec	0.8 km/h 12.5 m/55 se

**Floor Loading Information**

GVW + Rated Load	2150 lbs	975 kg
Axle load, maximum	1331 lbs	604 kg
Wheel load, maximum	767 lbs	348 kg

Note: Floor loading information is approximate and does not incorporate different option configurations. It should be used only with adequate safety factors.

Continuous improvement of our products is a Genie policy. Product specifications are subject to change without notice or obligation.

SPECIFICATIONS

<b>GR-15</b>		
Height, working maximum	21 ft 2 in	6.45 m
Height, platform maximum	15 ft 2 in	4.62 m
Height, stowed maximum including work station tray, ANSI & CSA	68 in	1.73 m
Height, stowed maximum including work station tray, CE	72.5 in	1.84 m
Width	29.5 in	75 cm
Length, stowed	53 in	1.35m
Length, platform extended	73 in	1.85 m
Maximum load capacity	350 lbs	159 kg
Maximum load capacity, fiberglass platform	350 lbs	159 kg
Turning radius (inside)	6 in	15 cm
Turning radius (outside)	62 in	1.57 m
Weight (Machine weights vary with option configurations)	See Serial Plate	
Gradeability	25%	
Power source	4 Batteries, 6V 225AH	
Controls	Proportional	
Platform dimensions, standard (length x width)	37 in x 29.5 in 94 cm x 75 cm	
Platform dimensions, platform with extension (length x width)	57 in x 29.5 in 1.45 m x 75 cm	
Fiberglass platform	26 x 22 x 43 <sup>1</sup> / <sub>2</sub> in 66 cm x 56 cm x 1.1 m	
AC outlet in platform	standard	
Tire size	10 x 3 x 1 in 25.4 x 7.6 x 2.5 cm	

Standard charger, Domestic	115V AC/60 HZ, 25 amp, 24V DC	
Standard charger, World wide	115V AC/60 HZ, 25 amp, 24V DC OR 230 V AC/50 HZ, 25 amp, 24V DC	
Standard charger, Europe	230 V AC/50 HZ, 25 amp, 24V DC	
Optional charger/inverter, Domestic	115V AC/60 HZ, 25 amp, 24V DC 1000 Watts	
Optional charger/inverter, World wide	230V AC/50 HZ, 25 amp, 24V DC 1000 Watts	
Airborne noise emissions	70 dB	
Maximum sound level at normal operating workstations (A-weighted)		

<b>Drive speeds</b>		
Stowed, maximum	2.5 mph	4.0 km/h
Platform raised, maximum	0.5 mph 40 ft/55 sec	0.8 km/h 12.5 m/55 se

<b>Floor Loading Information</b>		
GVW + Rated Load	2500 lbs	1134 kg
Axle load, maximum	1466 lbs	665 kg
Wheel load, maximum	980 lbs	445 kg

Note: Floor loading information is approximate and does not incorporate different option configurations. It should be used only with adequate safety factors.

Continuous improvement of our products is a Genie policy. Product specifications are subject to change without notice or obligation.

---

**Genie Holland**  
**Phone** +31 70 51 78836  
**Fax** +31 70 51 13993

---

**Genie Scandinavia**  
**Phone** +46 31 3409612  
**Fax** +46 31 3409613

---

**Genie France**  
**Phone** +33 (0)2 37 26 09 99  
**Fax** +33 (0)2 37 26 09 98

---

**Genie Ibérica**  
**Phone** +34 93 579 5042  
**Fax** +34 93 579 5059

---

**Genie Germany**  
**Phone** +49 (0)4202 88520  
**Fax** +49 (0)4202 8852-20

---

**Genie U.K.**  
**Phone** +44 (0)1476 584333  
**Fax** +44 (0)1476 584334

---

**Genie Mexico City**  
**Phone** +52 55 5666 5242  
**Fax** +52 55 5666 3241

**Genie North America**  
**Phone** 425.881.1800  
**Toll Free** USA and Canada  
800.536.1800  
**Fax** 425.883.3475

---

**Genie Australia Pty Ltd.**  
**Phone** +61 7 3375 1660  
**Fax** +61 7 3375 1002

---

**Genie China**  
**Phone** +86 21 53852570  
**Fax** +86 21 53852569

---

**Genie Malaysia**  
**Phone** +60 4 228 1235  
**Fax** +60 4 226 6872

---

**Genie Japan**  
**Phone** +81 3 3453 6082  
**Fax** +81 3 3453 6083

---

**Genie Korea**  
**Phone** +82 2 558 7267  
**Fax** +82 2 558 3910

---

**Genie Africa**  
**Phone** +27 11 455 0373  
**Fax** +27 11 455 0355

---

**Genie Latin America**  
**Phone** +55 11 4055 2499  
**Fax** +55 11 4043 1661

Distributed By: