

# OPERATOR'S SAFETY AND SERVICE MANUAL



## MK8 90

This manual covers the following serial numbers  
and higher for each model listed:

MK8-90 ..... 1760001



## RIDE ON TROWELS

**MBW, Inc.**  
250 Hartford Rd • PO Box 440  
Slinger, WI 53086-0440  
Phone: (262) 644-5234  
Fax: (262) 644-5169  
Email: [mbw@mbw.com](mailto:mbw@mbw.com)  
Website: [www.mbw.com](http://www.mbw.com)

**MBW (UK) Ltd.**  
Units 2 & 3 Cochrane Street  
Bolton BL3 6BN, England  
Phone: 01204 387784  
Fax: 01204 387797

L18255 / 08.04.A  
©MBW, Inc. 2004  
Printed in the USA

# TABLE OF CONTENTS

---

<b>Safety Information</b> . . . . .	<b>1</b>	Storage . . . . .	7
Introduction . . . . .	1	Changing Trowel Blades . . . . .	7
Safety Precautions . . . . .	1	Correct attachment of standard blades . . . . .	7
Safety Decals . . . . .	1	Replacing The Battery . . . . .	7
<b>Specifications</b> . . . . .	<b>3</b>	Replacing The Belts . . . . .	8
<b>Operation</b> . . . . .	<b>4</b>	Replacing The Floats . . . . .	8
Introduction . . . . .	4	<b>Service</b> . . . . .	<b>9</b>
Before Starting & Operating . . . . .	4	Torque Chart . . . . .	9
Starting Engine . . . . .	4	Parts Replacement Cycles and Tolerances . . . . .	9
Operating . . . . .	4	<b>Replacement Parts</b> . . . . .	<b>10</b>
Stopping Engine . . . . .	5	Main Assembly . . . . .	11
Stopping in emergency conditions: . . . . .	5	Tank Assemblies . . . . .	12
<b>Maintenance</b> . . . . .	<b>6</b>	Control Assembly . . . . .	13
Maintenance Schedule . . . . .	6	Drive Assembly . . . . .	14
Fluid Levels . . . . .	6	Right Blade and Gearbox Assembly . . . . .	15
Engine Maintenance . . . . .	6	Left Blade and Gearbox Assembly . . . . .	16
Engine Speed . . . . .	6	Engine Assembly . . . . .	17
Cleaning . . . . .	6	Frame Assembly . . . . .	18
Reduction Gear Oil . . . . .	6	Lifting Sling and Cart . . . . .	19
Lifting . . . . .	7	<b>Warranty</b> . . . . .	<b>20</b>



# **WARNING**



## **CALIFORNIA PROPOSITION 65 WARNING**

Engine exhaust and some of its constituents are known in the state of California to cause cancer, birth defects, and other reproductive harm.

# SAFETY INFORMATION

## Introduction



This Safety Alert Symbol is used to call attention to items or operations which may be dangerous to those operating or working with this equipment. The symbol can be found throughout this manual and on the unit. Please read these warnings and cautions, along with all decals, carefully before attempting to operate the unit. Make sure every individual who operates or works with this equipment is familiar with all safety precautions.

### **WARNING**

**GENERAL WARNING.** Indicates information important to the proper operation of the equipment. Failure to observe may result in damage to the equipment and/or severe bodily injury or death.

### **CAUTION**

**GENERAL CAUTION.** Indicates information important to the proper operation of the equipment. Failure to observe may result in damage to the equipment.

## Safety Precautions



**LETHAL EXHAUST GAS:** An internal combustion engine discharges carbon monoxide, a poisonous, odorless, invisible gas. Death or serious illness may result if inhaled. Operate only in an area with proper ventilation. **NEVER OPERATE IN A CONFINED AREA!**



**DANGEROUS FUELS:** Use extreme caution when storing, handling and using fuels, as they are highly volatile and explosive in vapor state. Do not add fuel while engine is running. Stop and cool the engine before adding fuel. **DO NOT SMOKE!**



**SAFETY GUARDS:** It is the owner's responsibility to ensure that all guards and shields are in place and in working order.



**IGNITION SYSTEMS:** Breakerless, magneto, and battery ignition systems can cause severe electrical shocks. Avoid contacting these units or their wiring.



**SAFE DRESS:** Do not wear loose clothing, rings, wristwatches, etc. near machinery.



**NOISE PROTECTION:** Wear OSHA specified hearing protection devices.



**EYE PROTECTION:** Wear OSHA specified eye shields, safety glasses, and sweat bands.



**FOOT PROTECTION:** Wear OSHA specified steel-tipped safety shoes.



**HEAD PROTECTION:** Wear OSHA specified safety helmets.



**DUST PROTECTION:** Wear OSHA specified dust mask or respirator.

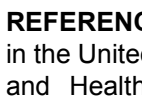

**OPERATOR:** Keep children and bystanders off and away from the equipment.

**REFERENCES:** For details on safety rules and regulations in the United States, contact your local Occupational Safety and Health Administration (OSHA) office. Equipment operated in other countries must be operated and serviced in accordance and compliance with any and all safety requirements of that country. The publication of these safety precautions is done for your information. MBW does not by the publication of these precautions, imply or in any way represent that these are the sum of all dangers present near MBW equipment. If you are operating MBW equipment, it is your responsibility to insure that such operation is in full accordance with all applicable safety requirements and codes. All requirements of the United States Federal Occupational Safety and Health Administration Act must be met when operated in areas that are under the jurisdiction of that United States Department.

## Safety Decals

Carefully read and follow all safety decals. Keep them in good condition. If decals become damaged, replace as required. If repainting the unit, replace all decals. Decals are available from authorized MBW distributors. Order the decal set listed on the following page(s).

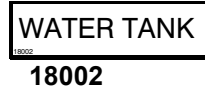
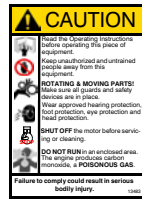

09311 (NOT IN DECAL SET)

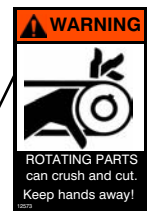
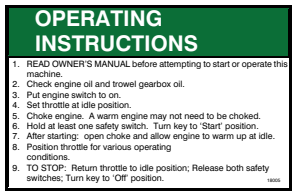

09867 (NOT IN DECAL SET)

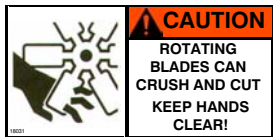
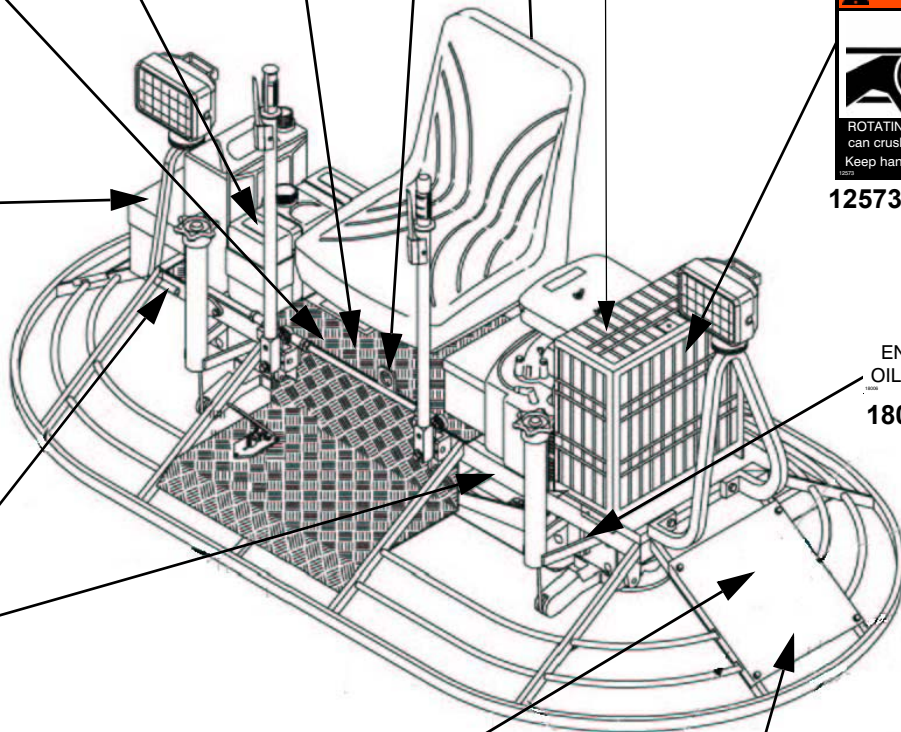

18031



09867 (NOT IN DECAL SET)

**LOWRIDER**  
 POWER TROWEL

18003 (NOT IN DECAL SET)

Safety Decals (Decal Set #18007)

# SPECIFICATIONS

---

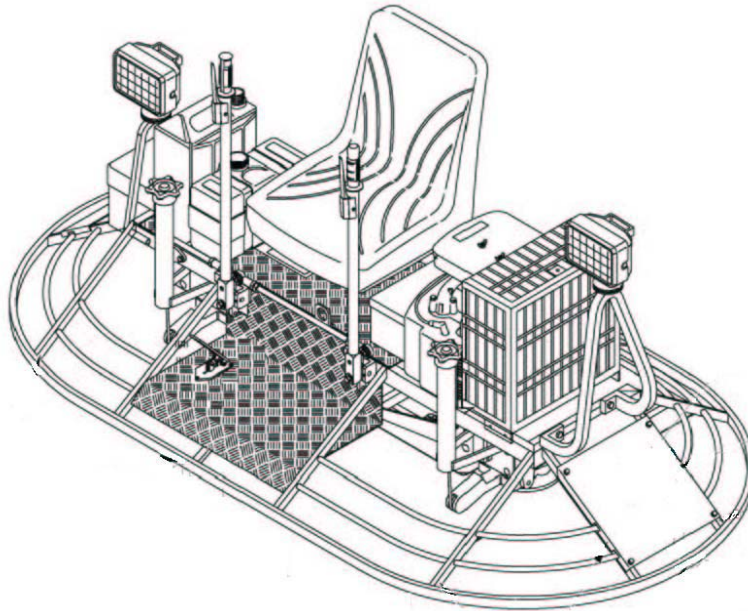

	<b>MK8 90</b>
<b>Dimensions</b>	80.7 x 40.5 x 41in. (2050x1030x1040mm)
<b>Weight</b>	628lbs. (285kg)
<b>Motor</b>	Kohler 20HP
<b>Max Engine RPM</b>	3600 RPM
<b>Min / Max Blade RPM</b>	70 / 125 RPM
<b>Rotor Diameter</b>	35.4in. (900mm)
<b>Max Forward Speed</b>	295 ft./min. (90 m/min.)
<b>Acoustic Level At Drivers Seat</b>	97.1 (dB)
<b>Trowel Path</b>	76in. (1930.4mm)

Specifications subject to change without notice



# OPERATION

---

## Introduction

MBW equipment is intended for use in very severe applications. They are powered by four cycle engines and are available in different sizes and a selection of engines.

This parts manual contains only standard parts. Variations of these parts as well as other special parts are not included. Contact your local MBW distributor for assistance in identifying parts not included in this manual.

## Before Starting & Operating

- **REMEMBER!** It is the owner's responsibility to communicate information on the safe use and proper operation of this unit to the operators.
- Review ALL of the Safety Precautions listed on page 1 of this manual.
- Familiarize yourself with the operation of the machine and confirm that all controls function properly.
- Know how to STOP the machine in case of an emergency.
- Make sure hands, feet, and clothing are at a safe distance from any moving parts.
- **OIL LEVEL** - Check the oil level in the engine. For more information see "Lubrication" under the respective engine's "Owners Manual" or the Maintenance section of this manual.
- **AIR CLEANER** - Check to ensure element is in good condition and properly installed.
- **FUEL SUPPLY** - The engines on MBW equipment require an automotive grade of clean, fresh, unleaded gasoline.
- **FUEL FILTER** - If clogged or damaged, replace.
- Make sure the machine is on a flat surface with a working area of at least 3,000 square feet, and that there is a sufficient area around the machine. (at least 6 ft.)
- See that the blade is inclined by at least 1/2" in order to have better control over the float machine when starting.
- Adjust seat if necessary.
- Make sure the two drive control levers are vertical and adjust if necessary.

## Starting Engine

1. Close the choke. Choking may not be necessary on warm engines.
2. Leave accelerator pedal at idle.
3. Hold one emergency stop lever closed and turn the start key.
4. Open the choke once engine is warm.

## Operating



### CAUTION



**To avoid premature clutch wear it is necessary to accelerate quickly upon start up then back the throttle off to the desired speed after the clutch is fully engaged.**

To drive the machine in the desired direction, there are two control levers. Move the controls slowly and smoothly. To stop the float machine return the control levers to the rest position. The control lever positions and the relevant movements are described on page 5 of this manual.

### Preparing the surface:

Use a mechanical vibrating float or manual float to level the floor surface in order to obtain a well-compacted concrete footing and thus prepare the ideal surface for floating and finishing. The float machine does not improve flatness of a badly floated or uneven floor.

### Floating phase:

The floor is ready for the first pass when the imprint of the shoe heel sinks into the concrete by about 1/8" when walking on it.

On average about 2700-3200 square feet of surface are floated in 10 minutes. Speed varies with conditions.

When the concrete is still fresh, take care not to work continuously on the same spot since, due to the weight of the float machine, you may create an uneven floor surface.

During the floating phase the floats must not chatter on the surface; this might be caused by dirt between the blades and the floats.

### Finishing phase:

When floating has been completed, detach the floats from the blades and clean the cement that has collected during the floating phase off the blades, the spider and the protection rim. Turn the blade-lifting knob clockwise until the blades are inclined by about 1/2" for the first pass; for the

subsequent smoothing operations continue increasing the blade inclination until obtaining the desired finish.

The time between one pass and the next is determined by the temperature and by the amount of water in the concrete. If the concrete has hardened too quickly in some areas, it can be moistened by spraying a small amount of water using the button located on the left control bar in order to obtain the degree of finish desired.

### Stopping Engine

1. Release the accelerator pedal to idle and release the two safety stop levers.
2. Close the fuel valve and remove the start key from the engine.

### Stopping in emergency conditions:

The safety stop levers are connected to two micro switches which cut the electric power to the engine; in case of an emergency, immediately release the levers.



**Always stop the engine before:**

**Adding fuel.**

**Leaving the equipment unattended for any amount of time.**

**Before making any repairs or adjustments to the machine.**

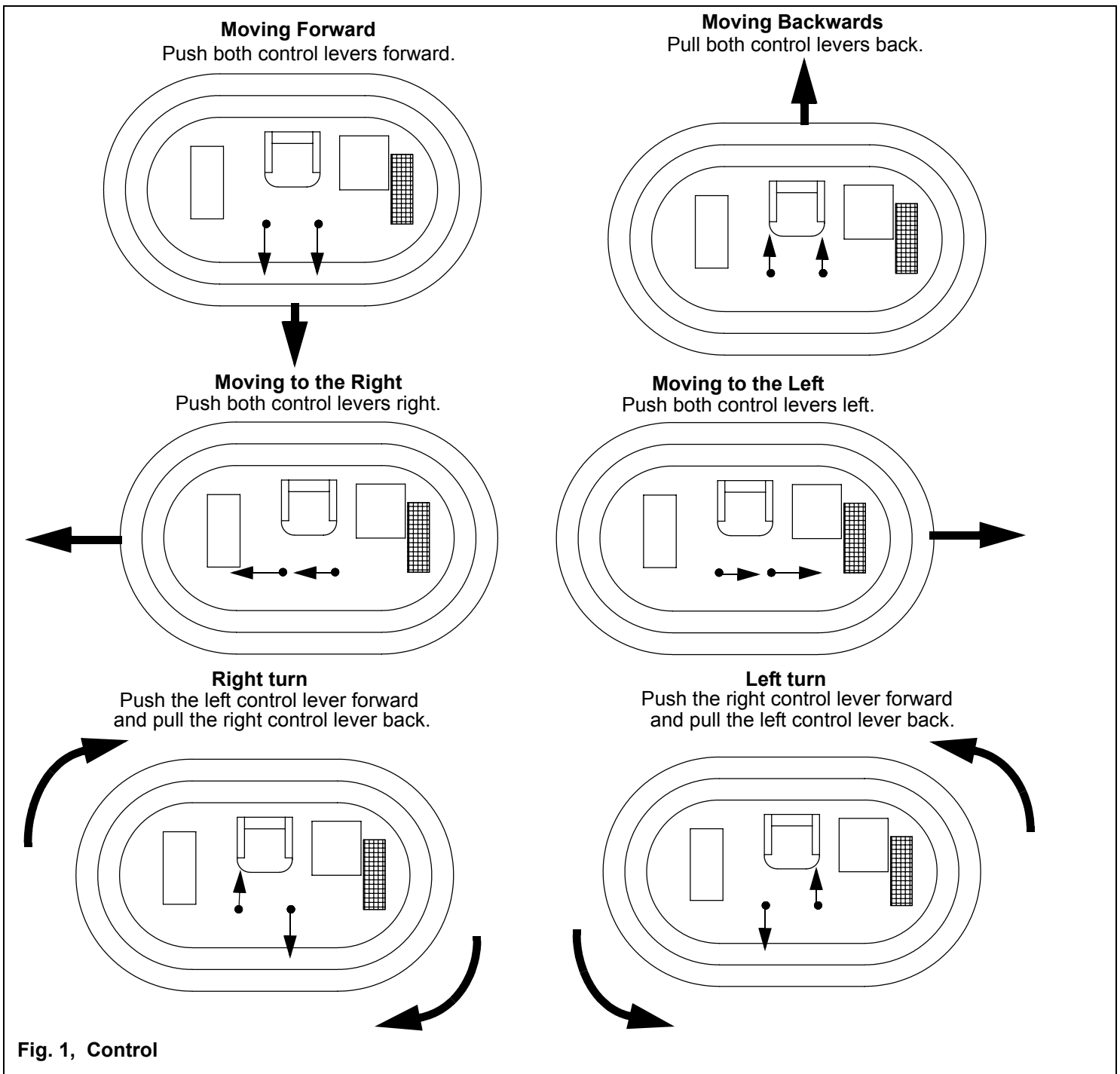

Fig. 1, Control



# MAINTENANCE



## WARNING



Always follow the stopping procedure before servicing or lubricating the unit.

After servicing the unit, replace and fasten all guards, shields, and covers to their original positions before resuming operation.



## CAUTION



Always verify fluid levels and check for leaks after changing fluids.

Do not drain oil onto ground, into open streams, or down sewage drains.

## Maintenance Schedule

SYSTEM	MAINTENANCE	DAILY	WEEKLY	EVERY 100 HOURS	YEARLY
	Clean machine thoroughly	X			
Engine	Refer to engine operator/owner manual	X			
	Clean air filter				X
Drive gear	Check wear and tensioning of belts		X		
	Grease drive shafts		X		
	Check reduction gear oil			X	
	Change gear oil				X
Battery	Check charge		X		
	Check water level			X	
	Clean posts			X	
Hardware	Check and tighten as needed	X			
	Check guard and blade hardware	X			

1. Check all hardware after the first 5 hours of use, then follow the maintenance schedule.

## Fluid Levels

SYSTEM	FLUID VOLUME	RECOMMENDED OIL
Gearbox	52oz	Cylinder/Gear Oil 460
Engine	Refer to engine operator/owner manual	

## Engine Maintenance

Refer to the engine owner's manual for maintenance intervals and procedures.

## Engine Speed

The engine speed is factory preset according to the speeds listed in the Specifications section. Do not tamper with the governor settings. The governor establishes safe operating limits that must not be exceeded.

## Cleaning

Clean the float machine at the end of each working day to prevent the cement from hardening on the machine. Wash the dirty parts with a brush and water. Wet the parts exposed to cement with "stripping" oil (never fuel oil). Do not oil the rubber moving parts (belts, etc.).

## Reduction Gear Oil

### Checking the Oil

1. Make sure machine is off.

2. Locate the sight gage on the outward side of the gearboxes.
3. Oil level should be centered in oil sight gage.

### Replacing the Oil

1. Remove the drain plug, located under the sight gage, and drain oil.
2. Replace drain plug.
3. Remove filler plug, located above sight gage, and fill until the sight gage is half full. Refer to Fluid levels on page 6 for type and quantity.
4. Replace filler plug.

### Lifting



**Never leave the floats attached to the float machine when lifting it more than 3ft. off the ground since it could detach and cause damage to people and things**

To lift the machine from one level to another use a hoisting crane or lift truck of suitable capacity. Weight can be found in Specifications, page 3.

To transport the machine on a truck place the blades in horizontal position using the control knobs; transporting the float machine with the blades inclined may damage the blade tilt system.

### Storage



**Never store the machine with fuel in the tank in places where the fuel vapors might come into contact with flames and/or sparks**

If you know that the machine will not be used for more than one month, drain the fuel from the tank in order to prevent the formation of rubbery deposits, and disconnect the battery.

If storing the machine in places where the temperature might drop to below freezing drain the water tank.

### Changing Trowel Blades



**Trowel blade edges may be sharp when they are worn. Wear protective gloves when handling the blades.**

Always check the state of wear of the blades and if they are damaged or bent, replace them. They must all be replaced at the same time.

1. Clean the machine.
2. Slightly lift the float machine off the ground (about 4").
3. Remove the blades by removing the bolts through arm.

**To replace the metric blades with standard you will need to use a bushing kit.**

4. Use one bushing per blade in hole closest to the spider.
5. Mount the new blades fixing a 5/16" x 1 3/4" bolt in the hole with the bushing and the smallest two of the holes. (You will now be using three bolts instead of two)
6. When the blades have been mounted, reposition the float machine on the ground.

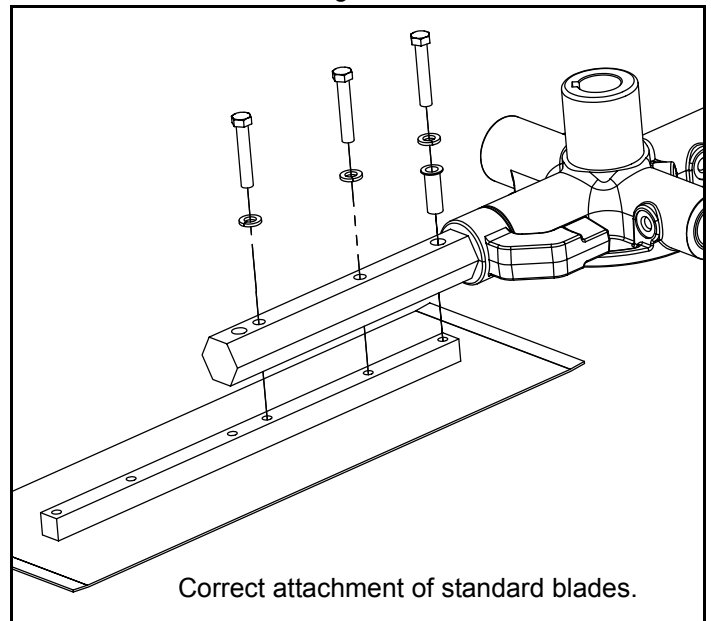

**Correct attachment of standard blades.**

### Replacing The Battery



**Handle the battery with particular care since it contains acid**

1. Remove the battery cover by unhooking the two hooks.
2. Remove the negative cable first.
3. Remove the battery and replace it with one with the same characteristics (45 Ah)

## Replacing The Belts

1. Changing the belts will be easier if the trowel blades are off the ground. This can be done by lifting the machine up and putting blocks under the guard ring to stabilize the unit.
2. Loosen belt tensioner jam nut located by engine oil filter.
3. Back out belt tensioner bolt 1 to 2 inches.
4. Idler bracket should slide back and belts should be loose. If not tap idler bracket back.
5. Remove belts by rolling them off the input sheave one at a time.

### Installing new belts

1. Install the replacement belts onto the clutch one at a time and roll them into their respective groove on the input sheave. Repeat this process for the remaining two belts.
2. Tighten tensioner bolt against idler bracket until belts have approximately  $\frac{1}{4}$  to  $\frac{1}{2}$ " deflection with moderate pressure applied to the back side of belts.

3. Tighten jam nut.
4. After unit is run belt tension should be rechecked and readjusted as needed.

## Replacing The Floats



### CAUTION



**Be careful when installing the floats: one rotor turns clockwise and the other counterclockwise, therefore you need to check that the various components have been properly arranged.**

1. Before mounting the floats, check that the blades are clean. The blades must be placed in horizontal position using the pitch control.
2. Slightly lift the float machine off the ground (about 4").
3. Mount the floats on the blades checking the correct direction of rotation.
4. When the floats have been mounted, reposition the float machine on the ground.

# SERVICE

Assembly and disassembly should be performed by a service technician who has been factory trained on MBW equipment. The unit should be clean and free of debris. Pressure washing before disassembly is recommended.

- Prior to assembly, wash all parts in a suitable cleaner or solvent.
- Check moving parts for wear and failure. Refer to the Replacement section in this manual for tolerance and replacement cycles.
- All shafts and housings should be oiled prior to pressing bearings. Also, ensure that the bearings are pressed square and are seated properly.
- All bearings should be replaced when rebuilding any exciter or gearbox.
- All gaskets and seals should be replaced after any disassembly.

## Torque Chart

SIZE	GRADE 2	GRADE 5	GRADE 8
1/4-20	49 in·lbs	76 in·lbs	9 ft·lbs
1/4-28	56 in·lbs	87 in·lbs	10 ft·lbs
5/16-18	8 ft·lbs	13 ft·lbs	18 ft·lbs
5/16-24	9 ft·lbs	14 ft·lbs	20 ft·lbs
3/8-16	15 ft·lbs	23 ft·lbs	33 ft·lbs
3/8-24	17 ft·lbs	26 ft·lbs	37 ft·lbs
7/16-14	24 ft·lbs	37 ft·lbs	52 ft·lbs
7/16-20	27 ft·lbs	41 ft·lbs	58 ft·lbs
1/2-13	37 ft·lbs	57 ft·lbs	80 ft·lbs
1/2-20	41 ft·lbs	64 ft·lbs	90 ft·lbs
9/16-12	53 ft·lbs	82 ft·lbs	115 ft·lbs
5/8-11	73 ft·lbs	112 ft·lbs	159 ft·lbs
5/8-18	83 ft·lbs	112 ft·lbs	180 ft·lbs
3/4-16	144 ft·lbs	200 ft·lbs	315 ft·lbs
1-8	188 ft·lbs	483 ft·lbs	682 ft·lbs
1-14	210 ft·lbs	541 ft·lbs	764 ft·lbs
1-1/2-6	652 ft·lbs	1462 ft·lbs	2371 ft·lbs
M 6	3 ft·lbs	4 ft·lbs	7 ft·lbs
M 8	6 ft·lbs	10 ft·lbs	18 ft·lbs
M 10	10 ft·lbs	20 ft·lbs	30 ft·lbs

**CONVERSIONS**  
in·lbs x 0.083 = ft·lbs  
ft·lbs x 12 = in·lbs  
ft·lbs x 0.1383 = kg·m  
ft·lbs x 1.3558 = N·m

## Parts Replacement Cycles and Tolerances

<b>Bearings</b>	Replace anytime a bearing is rough, binding, discolored or removed from housing or shaft.
<b>Engine Components</b>	Refer to your engine manufacturer's Owner's Manual.
<b>Hardware</b>	Replace any worn or damaged hardware as needed. Replacement hardware should be grade 5 and zinc plated unless otherwise specified.
<b>Safety Decals</b>	Replace if they become damaged or illegible.
<b>Seals &amp; Gaskets</b>	Replace if a leak is detected and at every overhaul or teardown.
<b>V-Belts</b>	Replace if cracked, torn, or stretched to the point the belt won't tension properly.

# REPLACEMENT PARTS

---

The warranty is stated in this book on page 20. Failure to return the Warranty Registration Card renders the warranty null and void.

MBW has established a network of reputable distributors/dealers with trained mechanics and full facilities for maintenance and rebuilding, and to carry an adequate parts stock in all areas of the country. Their sales engineers are available for professional consultation. If you cannot locate an MBW distributor in your area, contact MBW or one of our Sales Branches listed below.

When ordering replacement parts, be sure to have the following information available:

- Model and Serial Number of machine when ordering MBW parts
- Model and Serial Number of engine when ordering engine parts
- Part Number, Description, and Quantity
- Company Name, Address, Zip Code, and Purchase Order Number
- Preferred method of shipping

**REMEMBER - You own the best! If repairs are needed, use only MBW parts purchased from authorized MBW distributors.**

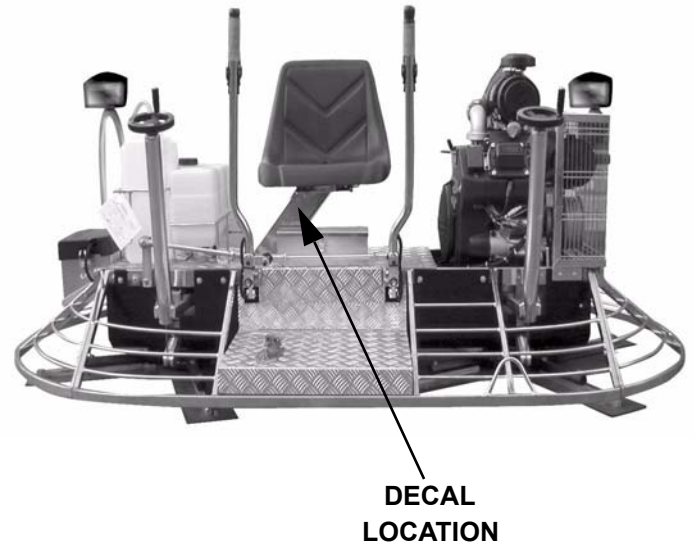

The unit's serial number is located on the side of the seat pedestal.

Write Model Number here

Write Serial Number here

---

## Contact Information

**MBW, Inc.**  
250 Hartford Rd • PO Box 440  
Slinger, WI 53086-0440  
Phone: (262) 644-5234  
Fax: (262) 644-5169  
Email: [mbw@mbw.com](mailto:mbw@mbw.com)  
Website: [www.mbw.com](http://www.mbw.com)

**MBW (UK) Ltd.**  
Units 2 & 3 Cochrane Street  
Bolton BL3 6BN, England  
Phone: 01204 387784  
Fax: 01204 387797

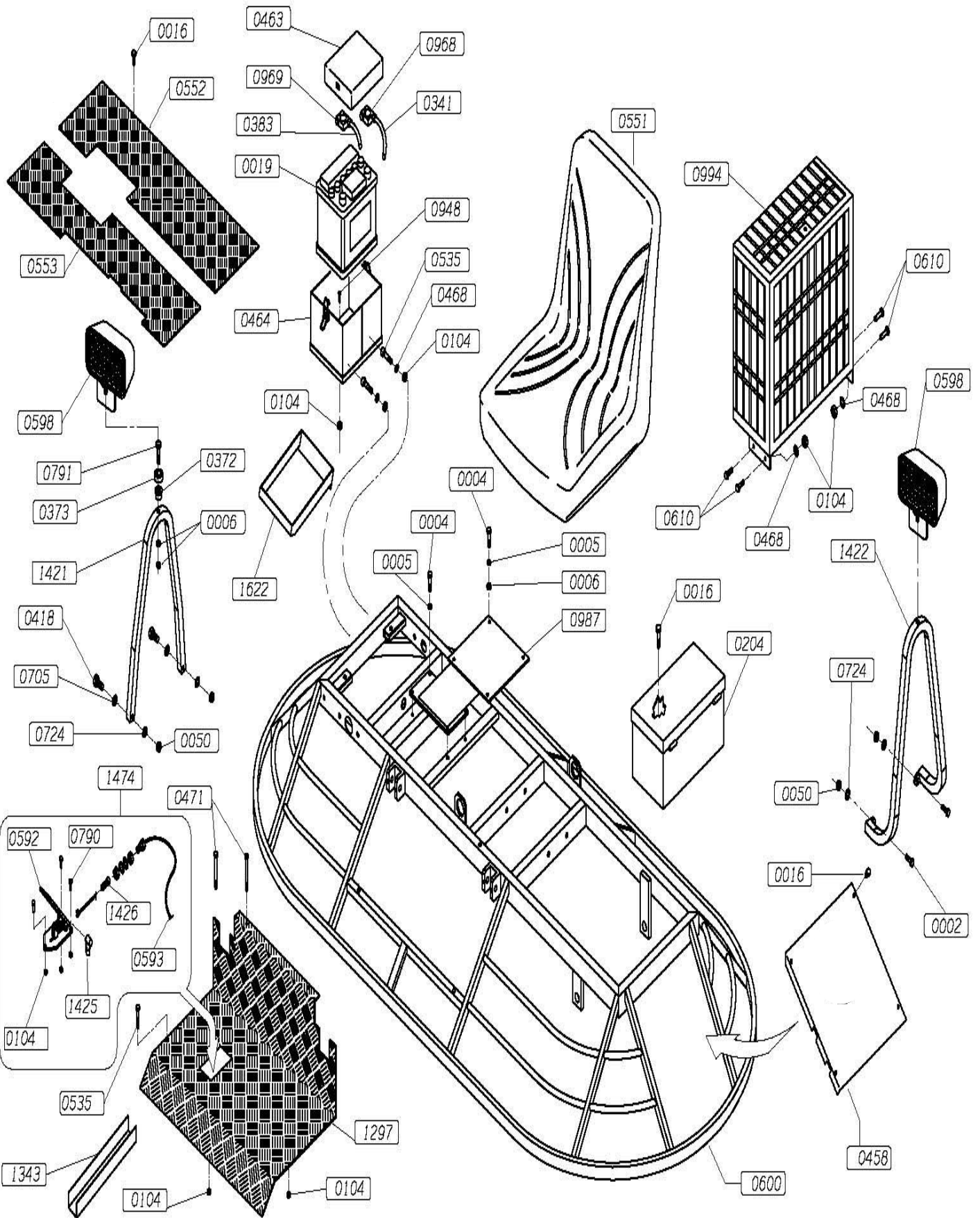

# Main Assembly



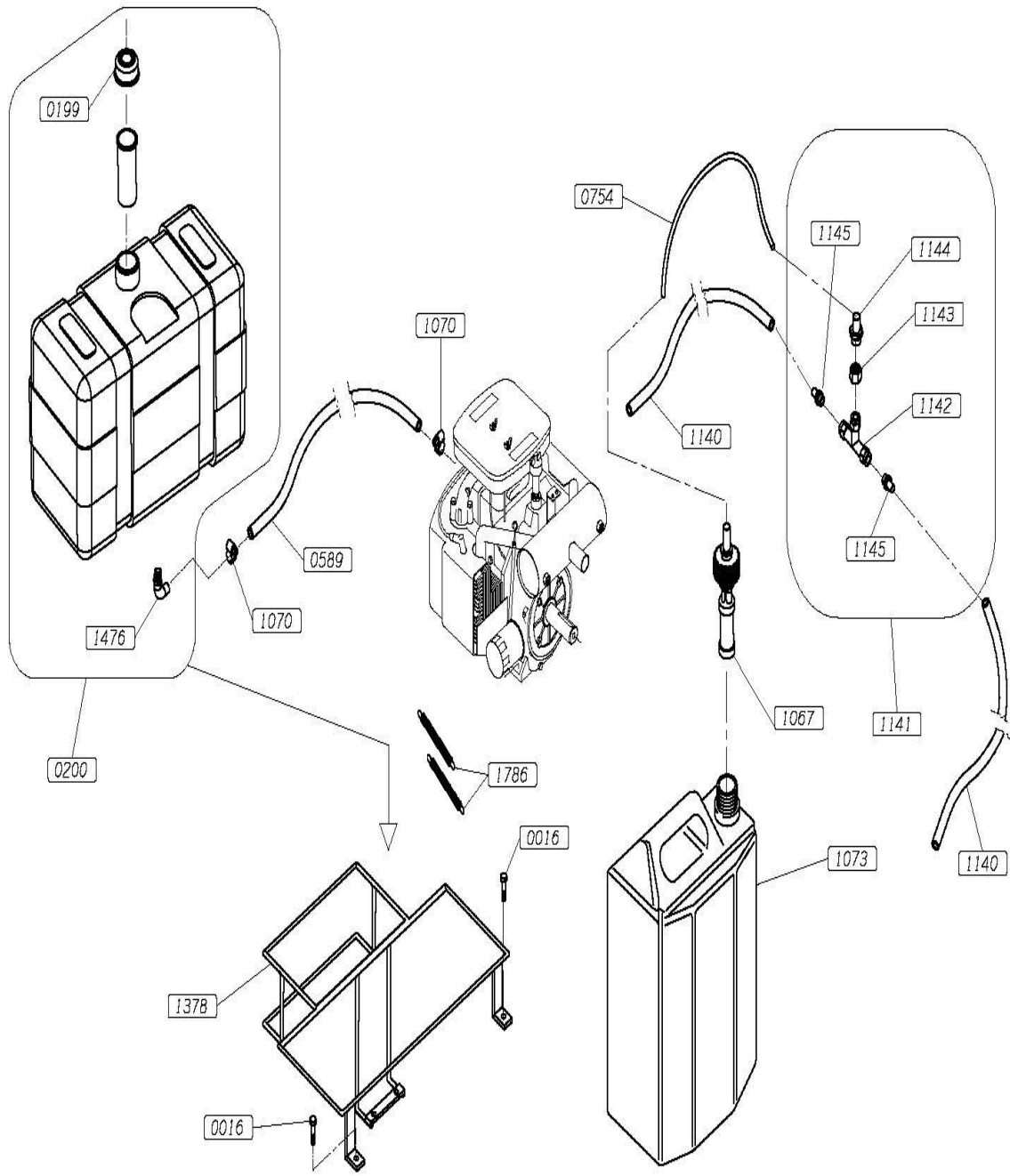

## Tank Assemblies

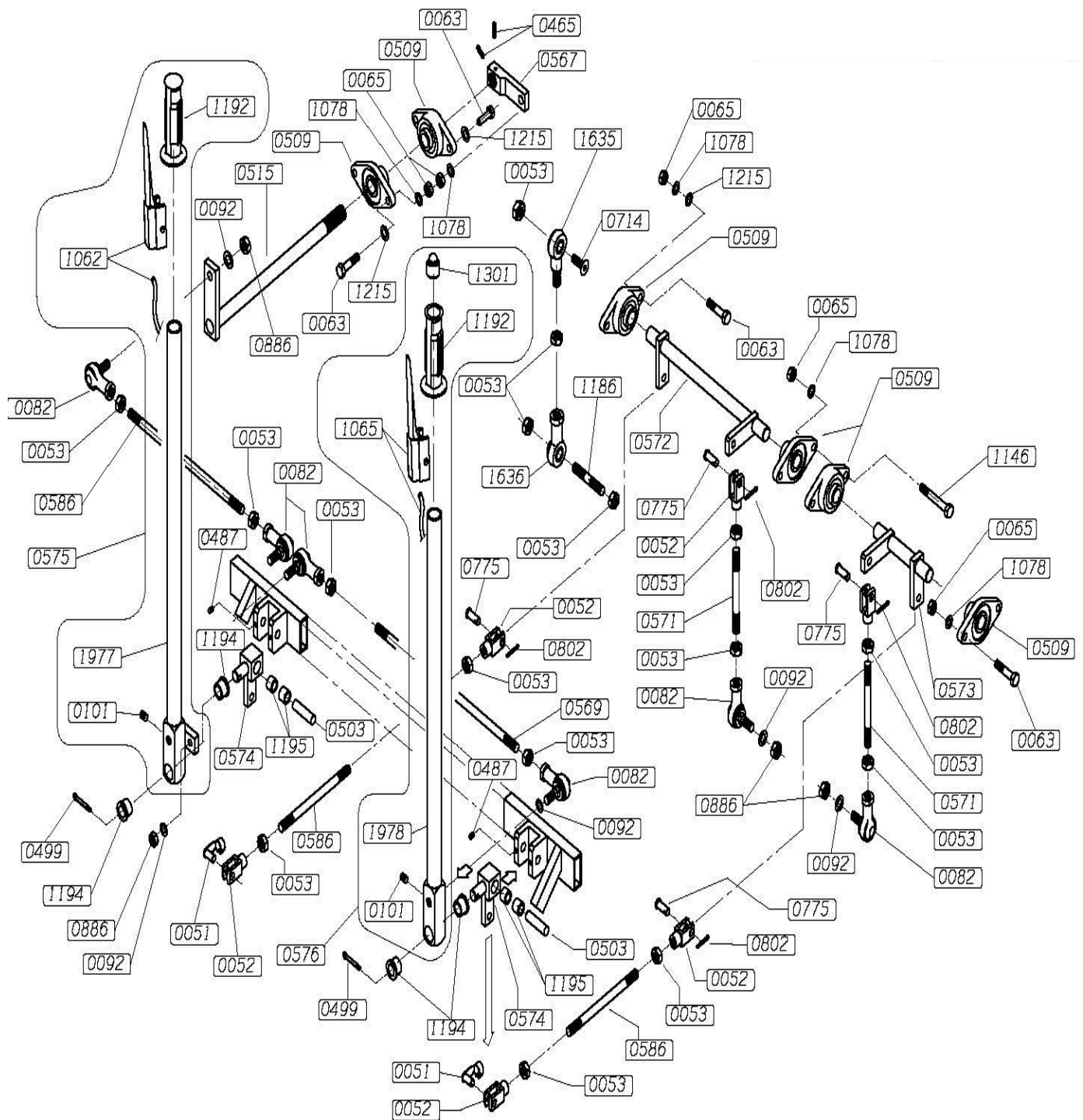

**Control Assembly**

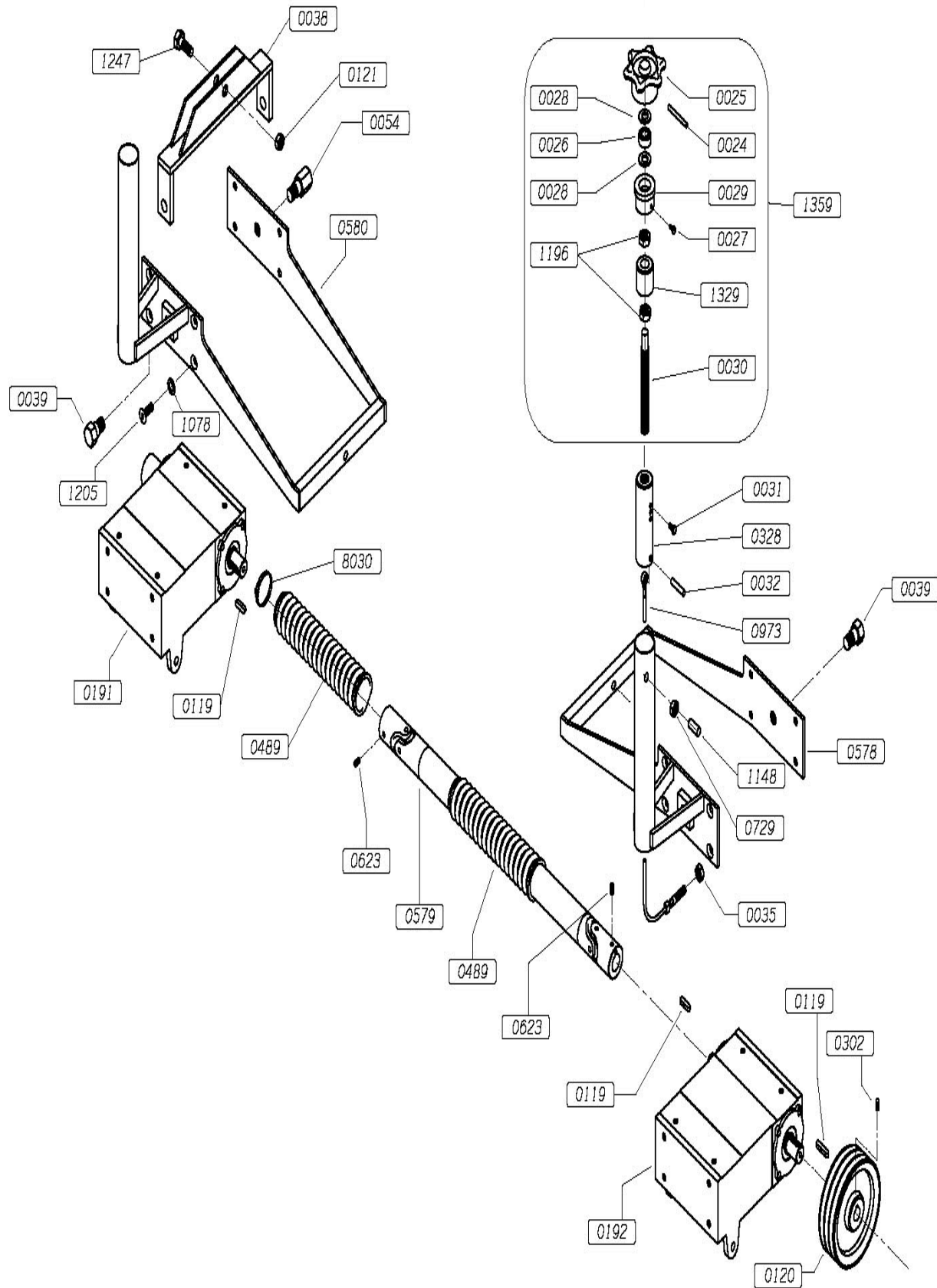

# Drive Assembly

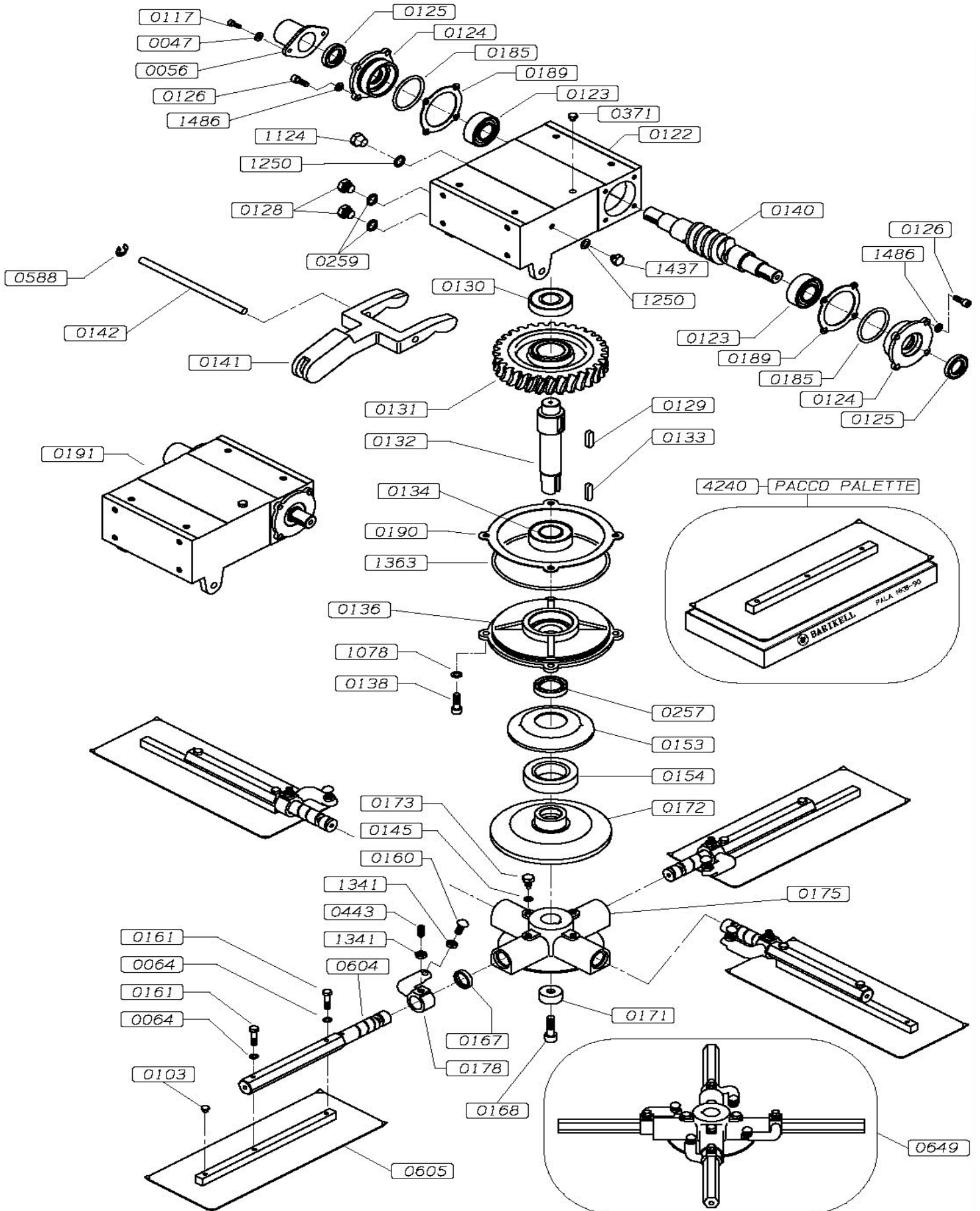

**Right Blade and Gearbox Assembly**

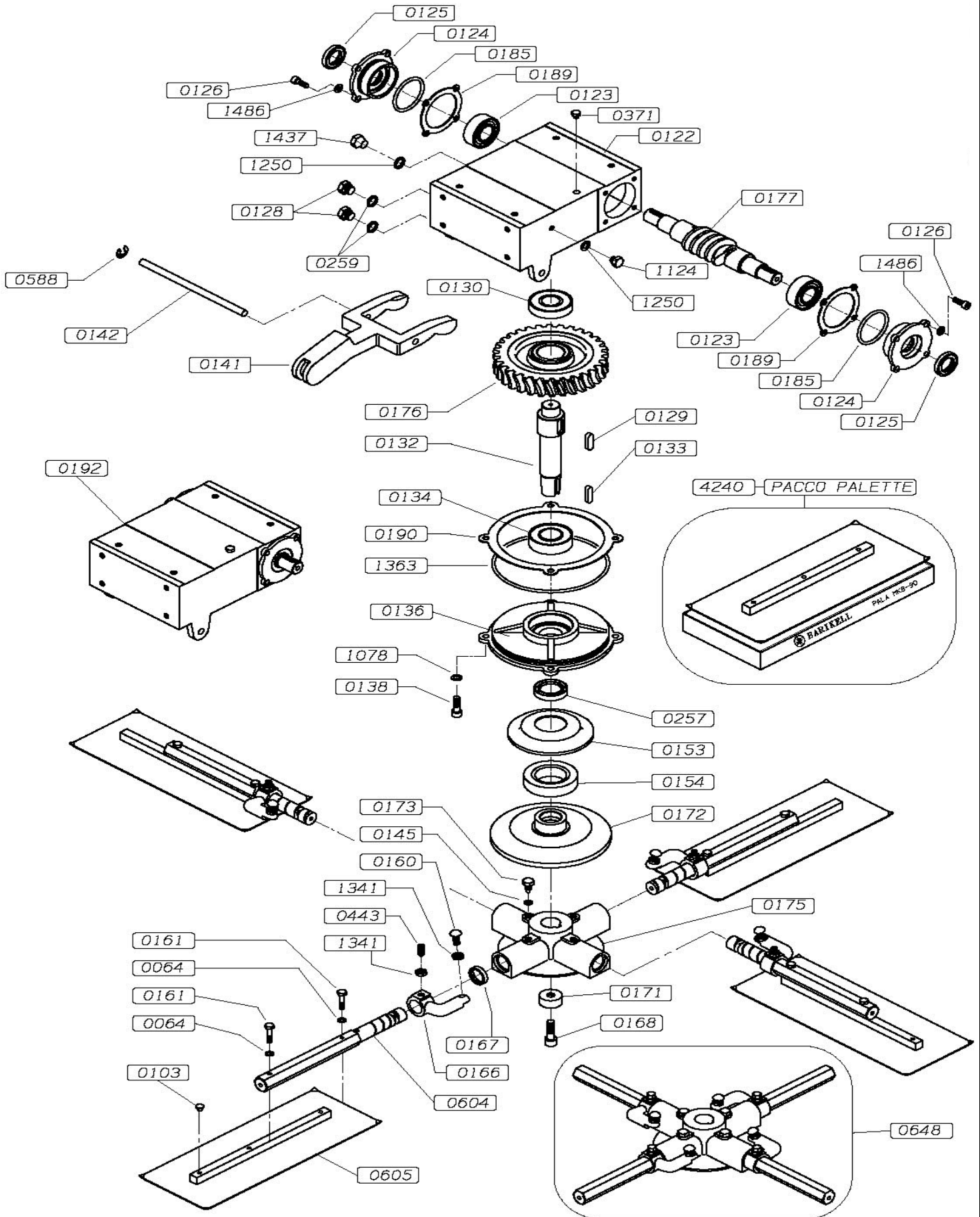

**Left Blade and Gearbox Assembly**

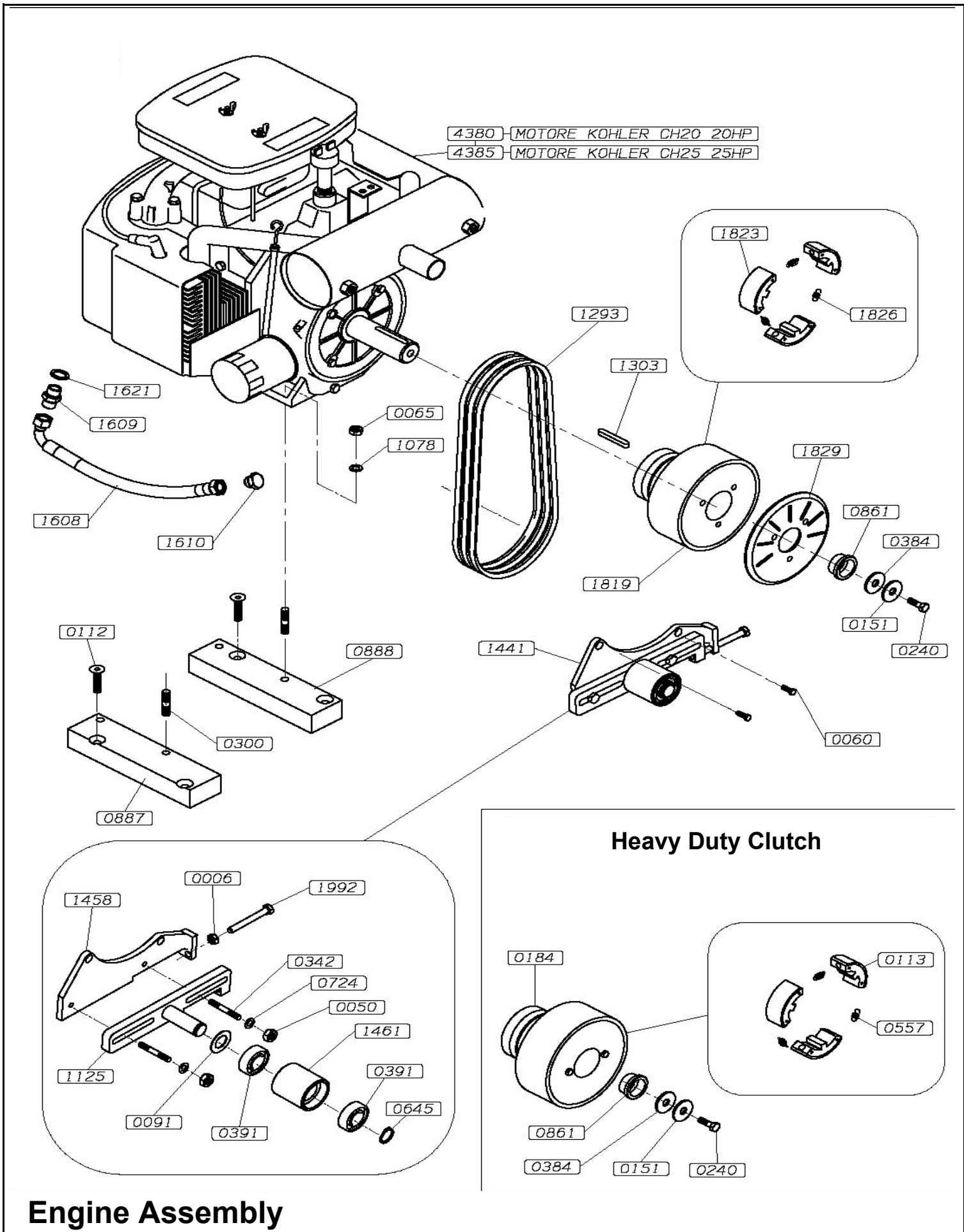



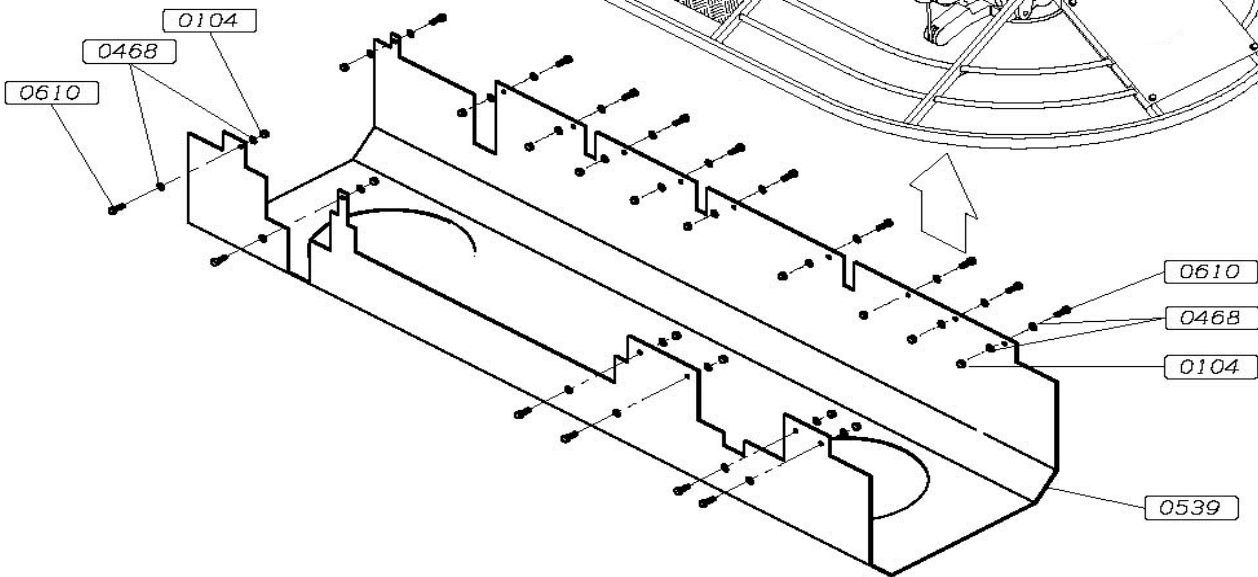
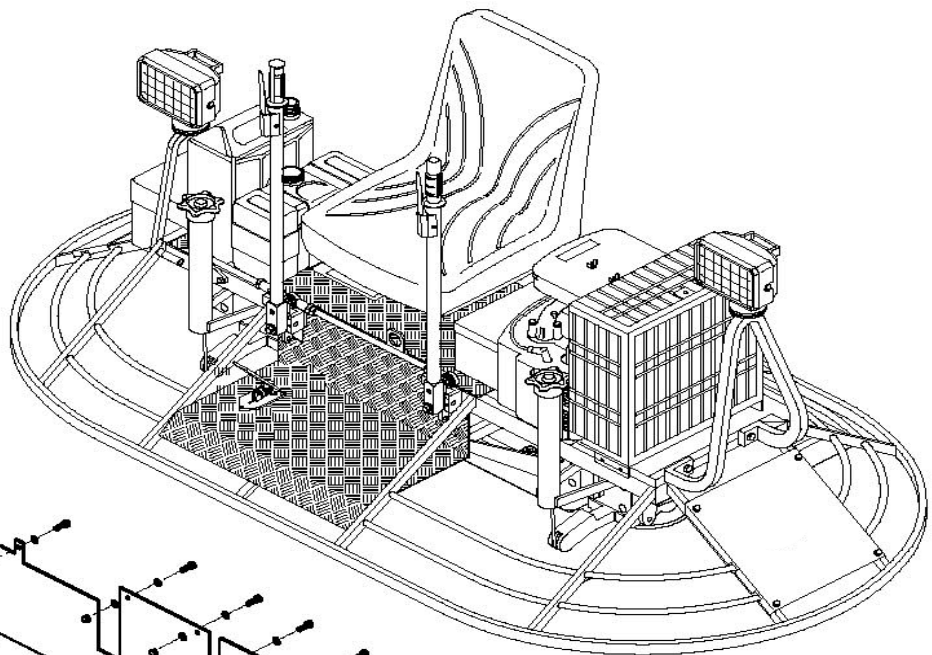

**OPTIONALS**

1631 CROCIERA SX COMPLETA CON INGRASSATORE

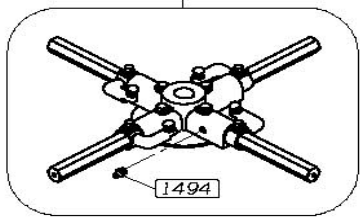

1630 CROCIERA DX COMPLETA CON INGRASSATORE

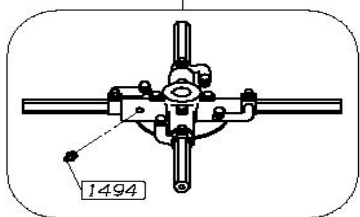

0963 CROCIERA CON INGRASSATORE

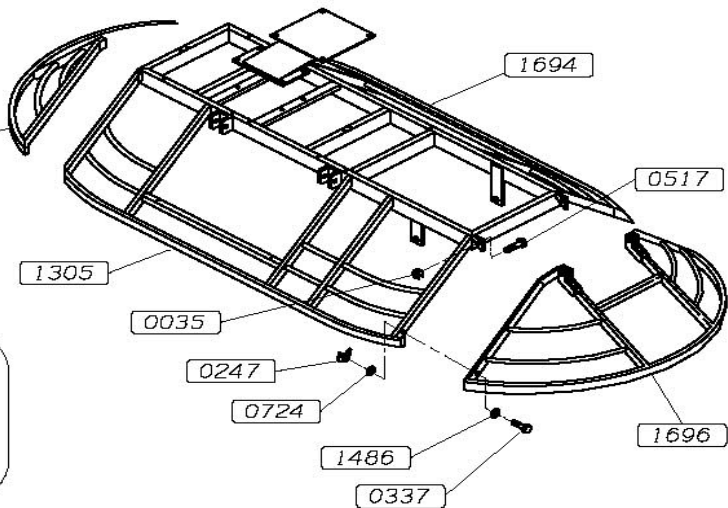
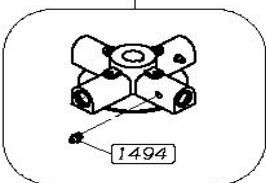

**Frame Assembly**

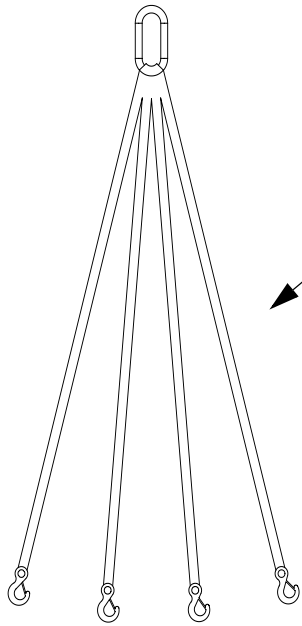

18260  
Lifting Sling

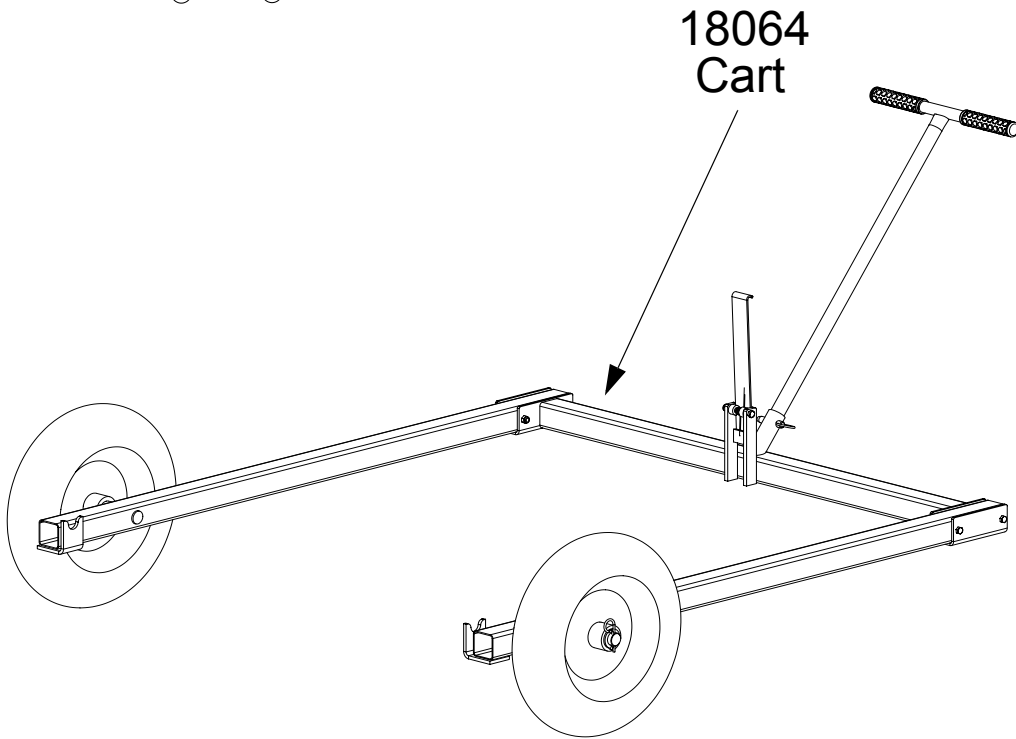

18064  
Cart

## Accessories

# WARRANTY

---

1. **MBW** warrants each new machine against defects in material and workmanship under normal use and service for a period of six (6) months. This warranty commences the first day the machine is sold, assigned to a rental fleet, or otherwise put to first use.
2. The obligation under this warranty is limited to the replacement or repair of parts and/or machine at **MBW** factory branches or at authorized **MBW** distributors.
3. Machines altered or modified without **MBW** written consent voids this warranty. Misuse, negligence, accidents or the operation of machines in any way other than recommended by **MBW** will void this warranty. This warranty shall not apply to machines repaired by other than **MBW** factory branches or authorized **MBW** distributors.
4. This warranty includes labor on all **MBW** products. Labor must be performed at an authorized **MBW** distributor.
5. The cost of transportation and other expenses connected therewith are not covered by this warranty.
6. Written authorization for the return of merchandise under warranty must be obtained from **MBW** or **MBW (UK) Limited**.
7. **MBW** reserves the right to inspect and render final decision on each warranty case.
8. **MBW** reserves the right to improve or make product changes without incurring any obligation to update, refit, or install the same on machines previously sold.
9. **MBW** is not responsible for any liability or damage or injury directly or indirectly from design, material or operation of its products.
10. Warranty card must be returned to **MBW** or **MBW (UK) Limited** within 10 days after purchase, assignment to a rental fleet, or first use. Failure to return warranty card as specified renders the warranty null and void.
11. Requests for warranty must be submitted within 30 days after machine failure to **MBW** or **MBW (UK) Limited**.
12. The foregoing warranty is expressly in lieu of all other warranties, expressed or implied, including the warranties of merchantability and fitness for use, and of all other obligation or liabilities on our part, and we neither assume nor authorize any other person to assume for us any other liability or warranty in connection with the sale or service of any of our products. Likewise, this warranty shall not apply with respect to engines, motors and other component parts produced by other manufactures and used on **MBW** products, but such items shall have such warranties as may be provided by the manufacturer thereof.



**MBW, Inc.**  
250 Hartford Rd • PO Box 440  
Slinger, WI 53086-0440  
Phone: (262) 644-5234  
Fax: (262) 644-5169  
Email: [mbw@mbw.com](mailto:mbw@mbw.com)  
Website: [www.mbw.com](http://www.mbw.com)

**MBW (UK) Ltd.**  
Units 2 & 3 Cochrane Street  
Bolton BL3 6BN, England  
Phone: 01204 387784  
Fax: 01204 387797