

With compliments

Helmut Singer Elektronik

www.helmut-singer.de info@helmut-singer.de

fon +49 241 155 315 fax +49 241 152 066

Feldchen 16-24 D-52070 Aachen Germany

POWER METERS

Power Sensors

Models 8481A/B, 8481H, 8482A/B, 8482H, 8483A, 8484A, 8485A, R/Q 8486A, 11708A

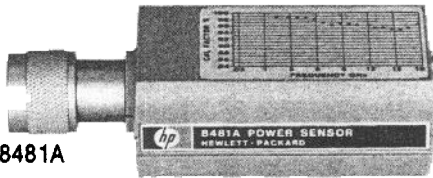

HP 8481A

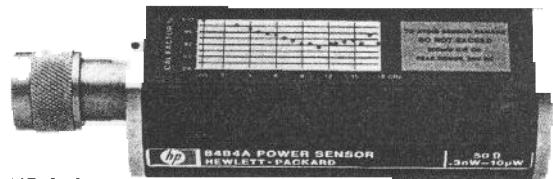

HP 8484A

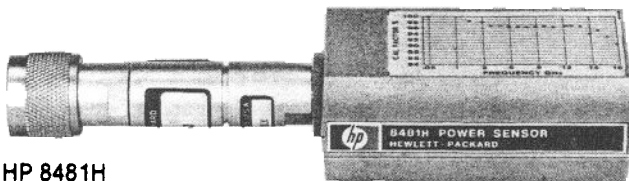

HP 8481H

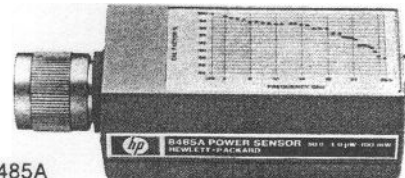

HP 8485A

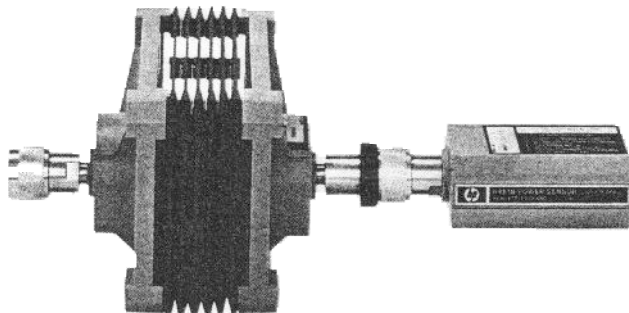

HP 8481B

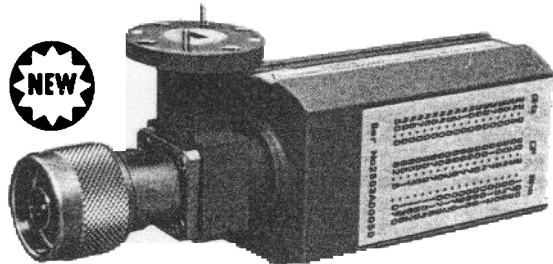

HP Q8486A

HP 8480 Series Power Sensors

The HP 8480 series of Power Sensors have been designed for use with the HP 435B, 436A, and 438A Power Meters. They feature wide frequency and power ranges in addition to very low SWR.

The power measurement range of these sensors is from 0.1 nW to 25 watts. With just three sensors a power measurement range of 114 dB can be achieved.

Wide Frequency Range for Many Applications

Power measurements can be made over a frequency range of 100 kHz to 50 GHz. The six frequency ranges covered with these units are 10 MHz to 18 GHz, 100 kHz to 4.2 GHz, and 50 MHz to 26.5 GHz, in 50 Ω sensors and 100 kHz to 2 GHz, with the 75-ohm sensor, and 26.5 to 40 GHz and 33 to 50 GHz in Waveguide.

Low SWR for Low Measurement Uncertainty

The HP 8481/82/83/85/86 series of sensors use a silicon monolithic thermocouple as the sensing element. The small physical size of the thermocouple enables the sensors to have a very low SWR even at 50 GHz. A low SWR reduces mismatch uncertainty error, typically the largest single source of error in power measurements. The HP 8484A sensor uses a crystal detector for higher sensitivity and low SWR.

Individually Calibrated for More Confidence in Results

Each sensor is individually calibrated, traceable to the National Bureau of Standards. A control on the meter compensates for power sensor Cal Factor at any frequency. A precise automatic network analyzer printout for Cal Factor and reflection coefficient in magnitude and phase is supplied with the HP 8481A/B/H, 8484A, and 8485A. This means you can significantly reduce mismatch uncertainty by calculating the mismatch error.

High Power Sensors to 25 Watts

The HP 8481B and 8482B High Power Sensors both have a power range of 1 mW to 25 watts. The HP 8481B covers a frequency range of 10 MHz to 18 GHz, 100 kHz to 4.2 GHz, and the HP 8482B has a frequency range of 100 kHz to 4.2 GHz.

Previous methods of measuring high power levels usually required adding a separate attenuator in front of a low power sensor. With the HP 8481/82B power sensors, the attenuator and sensor are combined into one unit. This reduces mismatch uncertainty error and improves accuracy by including the attenuator in the measured Calibration Factor curves. In addition, light-weight, heat-dissipating fins on the attenuator prevent burns.

Medium Power Sensors to 3 Watts

The HP 8481H measures power from 100 μ W to 3 watts over a frequency range of 10 MHz to 18 GHz. The HP 8482H measures power from 30 μ W to 3 watts over a frequency range of 100 kHz to 4.2 GHz.

Standard Sensors to 100 mW

The HP 8481A, 8482A, 8483A, and 8485A Power Sensors all measure power over a range of 1 μ W to 100 mW. The HP 8481A is a 50-ohm sensor with a frequency range of 10 MHz to 18 GHz. The HP 8482A is a 50-ohm sensor with a frequency range of 100 kHz to 4.2 GHz. The HP 8485A is a 50-ohm sensor with a frequency range of 50 MHz to 26.5 GHz. The HP 8483A is a 75-ohm sensor and covers a frequency range of 100 kHz to 2 GHz.

High Sensitivity Sensors

The HP 8484A measures power from 0.1 nW to 10 μ W over a frequency range of 10 MHz to 18 GHz. It is furnished with the HP 11708A 50 MHz reference attenuator for precise calibration with 1 mW power meter reference oscillator. Noise and drift have been reduced to less than 5% of full scale on the 300 pW range (only 15 pW) when it is used with the HP 435B power meter. Noise and drift are even less with the HP 436A and 438A power meters.

Millimeter-Wave Power Sensors

The HP R8486A and Q8486A Thermocouple Waveguide Power Sensors measure true, average power from 1 μ W to 100 mW over the frequency ranges of 26.5 to 40 GHz (R-band) and 33 to 50 GHz (Q-band).

HP 8480 Series Specifications

HP Model (Nominal Impedance)	Frequency Range	Power Range	Maximum Power	Power Linearity ²	Maximum SWR (Reflection Coefficient)	Size mm (in.)		RF Connector
						Shipping Weight kg (lb)		
8481A (50 Ω)	10 MHz-18 GHz	1 μW to 100 mW	300 mW avg. 15 W peak 30 W • μs (per pulse)	+10 to +20 dBm ±2, -4%	10 MHz - 30 MHz: 1.40 (0.166) 30 MHz - 50 MHz: 1.18 (0.083) 50 MHz - 2 GHz: 1.10 (0.048) 2 - 12.4 GHz: 1.18 (0.083) 12.4 - 18 GHz: 1.28 (0.123)	30 x 38 x 105 (1.2 x 1.5 x 4.1)	0.5 (1)	N(m)
Option 001						83 x 114 x 248 (3.25 x 4.5 x 9.75)		
8481B (50 Ω)	10 MHz-18 GHz	0-35°C: 1 mW-25W; 35°C-55°C: 1 mW-20 W	0-35°C: 30 W avg. 1 25 W peak 25 W avg.	+35 to +44 dBm ±4%	10 MHz - 2 GHz: 1.10 (0.048) 2-12.4 GHz: 1.18 (0.083) 12.4-18 GHz: 1.28 (0.123)	1.5 (3.2)	500 W • μs (per pulse)	N(m)
			10 MHz-5.8 GHz 500 W peak 5.8-18 GHz 125 W peak			1.5 (3.2)		
			500 W • μs (per pulse)					
8481H (50 Ω)	10 MHz-18 GHz	100 μW to 3W	3.5 W avg. 100 W peak 100W • μs (per pulse)	+25 to +35 dBm ±5%	10 MHz - 8 GHz: 1.20 (0.091) 8-12.4 GHz: 1.25 (0.110) 12.4 - 18 GHz: 1.30 (0.130)	30 x 38 x 149 (1.2 x 1.5 x 5.9)	0.5 (1)	N(m)
8482A (50 Ω)	100 kHz-4.2 GHz	1.0 μW to 100 mW	300 mW avg. 15 W peak 30 W • μs (per pulse)	-10 to +20 dBm -2, -4%	100-300 kHz: 1.60 (0.231) 300 kHz - 1 MHz: 1.20 (0.091) 1 MHz - 2 GHz: 1.10 (0.048) 2-4.2 GHz: 1.30 (0.130)	30 x 38 x 105 (1.2 x 1.5 x 4.1)	0.5 (1)	N(m)
8482B (50 Ω)	100 kHz-4.2 GHz	0-35°C: 1 mW-25 W; 35°C-55°C: 1 mW-20 W	0-35°C: 30 W avg. 1 25 W peak 25 W avg.	+35 to +44 dBm ±4%	100 kHz - 2 GHz: 1.10 (0.048) 2 GHz - 4.2 GHz: 1.18 (0.083)	1.5 (3.2)	500 W peak 500 W • μs (per pulse)	N(m)
			500 W peak			1.5 (3.2)		
			500 W • μs (per pulse)					
8482H (50 Ω)	100 kHz-4.2 GHz	100 μW to 3W	3.5 W avg. 100 W peak 100 W • μs (per pulse)	+25 to +35 dBm ±5%	100 kHz-4.2 GHz: 1.20 (0.091)	30 x 38 x 149 (1.2 x 1.5 x 5.9)	0.5 (1)	N(m)
8483A ³ (75 Ω)	100 kHz-2 GHz	1.0 μW to 100 mW	300 mW avg. 10 W peak 30 W • μs (per pulse)	+10 to +20 dBm +2, -4%	100-600 kHz: 1.80 (0.286) 600 kHz - 2 GHz: 1.18 (0.083)	30 x 38 x 105 (1.2 x 1.5 x 4.1)	0.5 (1)	N(m) 75 Ω
8484A ⁴ (50 Ω)	10 MHz-18 GHz	0.1 nW to 10 μW	200 mW avg. 200 mW peak	-30 to -20 dBm ±1%	10-30 MHz: 1.40 (0.166) 30 MHz - 4 GHz: 1.15 (0.070) 4-10 GHz: 1.20 (0.091) 10-15 GHz: 1.30 (0.130) 15-18 GHz: 1.35 (0.149)	36 x 44 x 133 (1.4 x 1.7 x 5.2)	0.5 (1)	N(m)
8485A (50 Ω)	50 MHz-26.5 GHz	1 μW to 100 mW	300 mW avg. 15 W peak 30 W • μs (per pulse)	+10 to +20 dBm +2, -4%	50 MHz-100 MHz: 1.15 (0.070) 100 MHz-2 GHz: 1.10 (0.048) 2-12.4 GHz: 1.15 (0.070) 12.4-18 GHz: 1.20 (0.091) 18-26.5 GHz: 1.25 (0.111)	30 x 38 x 95 (1.2 x 1.5 x 3.7)	0.5 (1)	APC-3.5(m)
R8486A (Waveguide)	26.5-40 GHz	1 μW to 100 mW	300 mW avg. 15 W peak 30W • μs pulse	+10 to +20 dBm +2, -4%	1.4 (0.167)	30 x 38 x 126 (1.2 x 1.5 x 5.0)	0.4 (0.9)	Waveguide Flange UG-599/U
Q8486A (Waveguide)	33-50 GHz	1 μW to 100 mW	300 mW avg. 15 W peak 30W • μs pulse	+10 to +20 dBm +2, -4%	1.5 6(0.200)	30 x 38 x 126 (1.2 x 1.5 x 5.0)	0.4 (0.9)	Waveguide Flange UG-383/U

¹For pulses greater than 30 W the maximum average power (Pa) is limited by the energy per pulse (E) in W • μs according to Pa = 30-0.02E.

²Negligible deviation except for those power ranges noted.

³Includes HP 1250-0597 adapter from 75 Ω type N to 50 Ω type N for calibration.

⁴The HP 11708A 30 dB attenuator for calibrating against a 0 dBm, 50 MHz power reference is shipped with the HP 8484A.

Uncertainty of Calibration Factor Data for HP 8482A and 8483A

Frequency (MHz)	Sum of Uncertainties (%) ¹				Probable Uncertainties (%) ²			
	HP Model				HP Model			
	8482A	8482B	8482H	8483A	8482A	8482B	8482H	8483A
0.1	±2.3	±5.7	±3.3	±2.6	±1.3	±2.8	±1.6	±1.5
0.3	2.2	5.7	3.2	2.5	1.2	2.8	1.6	1.4
1.0	2.2	5.7	3.2	2.5	1.2	2.8	1.6	1.4
3.0	2.2	5.7	3.2	2.5	1.2	2.8	1.6	1.4
10.0	2.5	5.7	3.5	3.0	1.3	2.8	1.6	1.6
30.0	2.6	5.7	3.6	3.1	1.4	2.8	1.7	1.6
50.0	0(ref)	2.7	0(ref)	0(ref)	0(ref)	2.7	0(ref)	0(ref)
100.0	3.1	5.6	4.1	3.9	1.6	3.3	1.9	2.0
300.0	3.1	5.6	4.1	3.9	1.6	3.3	1.9	2.0
1000.0	2.7	5.7	3.7	3.7	1.4	3.3	1.7	2.0
2000.0	2.7	5.5	3.7	3.9	1.4	3.1	1.7	2.1
4000.0	2.8	5.5	3.8	—	1.5	3.1	1.8	—

Uncertainty of Calibration Factor Data for HP 8481A/B, 8484A 8485A³

Frequency (GHz)	Sum of Uncertainties (%) ¹					Probable Uncertainties (%) ²				
	HP Model					HP Model				
	8481A	8481B	8481H	8484A	8485A	8481A	8481B	8481H	8484A	8485A
0.1	±3.1	±6.4	±4.1	±4.4	—	±1.6	±3.0	±1.9	±1.9	—
2	2.7	5.8	3.7	4.0	±3.6	1.4	3.1	1.7	1.8	±2.1
4	2.8	5.8	3.8	4.1	—	1.5	3.1	1.8	1.8	—
6	2.8	5.8	3.8	4.1	4.0	1.5	3.1	1.8	1.8	2.3
8	3.2	6.0	4.2	4.6	—	1.7	3.2	2.0	2.0	—
10	3.6	6.2	4.6	5.1	4.7	1.9	3.3	2.2	2.2	2.7
12	3.9	7.8	4.9	6.5	—	2.1	4.1	2.4	2.8	—
14	4.8	7.9	5.8	7.4	5.6	2.6	4.1	2.8	3.2	3.2
16	5.2	8.0	6.2	7.8	—	2.9	4.2	3.0	3.4	—
18	5.8	8.3	6.8	8.4	5.9	3.2	4.3	3.4	3.7	3.6
22	—	—	—	—	6.8	—	—	—	—	3.7
26.5	—	—	—	—	7.3	—	—	—	—	4.0

¹Includes uncertainty of reference standard and transfer uncertainty. Directly traceable to NBS.

²Square root of sum of the individual uncertainties squared (RSS).

³For R/Q8486A uncertainty data see the data sheet (5953-6482).

With compliments

Helmut Singer Elektronik

www.helmut-singer.de info@helmut-singer.de
fon +49 241 155 315 fax +49 241 152 066
Feldchen 16-24 D-52070 Aachen Germany

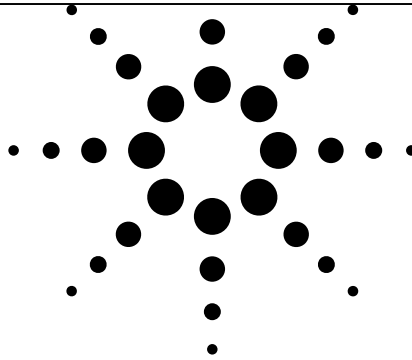

**Agilent
EPM Series Power Meters
E-Series and 8480 Series Power Sensors**

Data Sheet

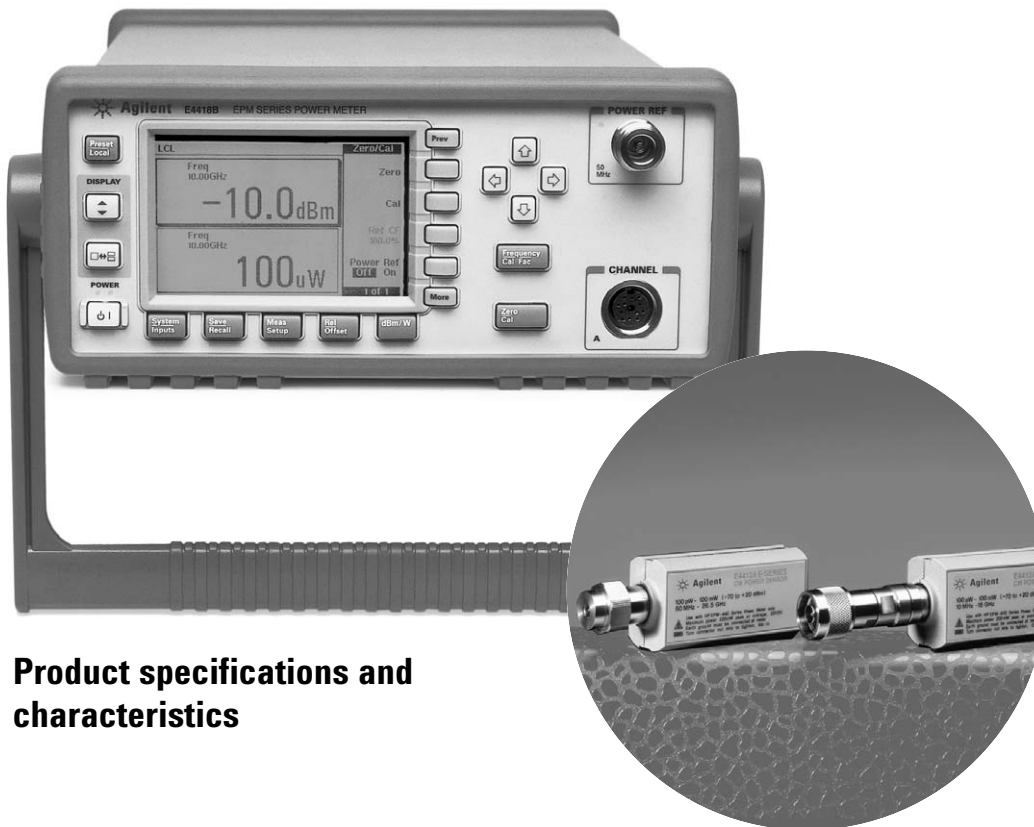

**Product specifications and
characteristics**

EPM series E4418B and E4419B power meters

Specifications

Specifications describe the instrument's warranted performance and apply after a 30 minute warm-up. These specifications are valid over its operating/environmental range unless otherwise stated and after performing a zero and calibration procedure.

Supplemental characteristics

Supplemental characteristics (shown in italics) are intended to provide additional information, useful in applying the instrument by giving typical (expected), but not warranted performance parameters. These characteristics are shown in italics or labeled as *typical*, *nominal* or *approximate*.

For information on measurement uncertainty calculations, refer to Application Note 64-1C, *Fundamentals of RF and Microwave Power Measurements*, literature number 5965-6380E.

Frequency range: 9 kHz to 110 GHz, sensor dependent

Power range: -70 dBm to +44 dBm (100 pW to 25 W), sensor dependent.

Power sensors: Compatible with all 8480 series and E-series sensors

Single sensor dynamic range: 90 dB maximum (E-series sensors), 50 dB maximum (8480 series sensors).

Display units:

Absolute: Watts or dBm.
Relative: Percent or dB.

Display resolution: Selectable resolution of 1.0, 0.1, 0.01, and 0.001 dB in Log mode, or 1 to 4 digits in linear mode.

Default resolution: 0.01 dB in log

mode, 3 digits in linear mode.

Accuracy

Instrumentation

Absolute: ± 0.02 dB (log) or $\pm 0.5\%$ (linear). Please add the corresponding power sensor linearity percentage from tables 7 and 10 (for the E-series sensors) and table 15 (for the 8480 series sensors).

Relative: ± 0.04 dB (Log) or $\pm 1.0\%$ (linear). Please add the corresponding power sensor linearity percentage from table 16 (for the 8480 series sensors).

Zero set (digital settability of zero):

sensor dependent (refer to table 1). For E-series sensors, this specification applies to a ZERO performed when the sensor input is not connected to the POWER REF.

Power reference

Power output: 1.00 mW (0.0 dBm).

Factory set to $\pm 0.4\%$ traceable to the National Physical Laboratory (NPL), UK¹.

Accuracy: For two years:

$\pm 0.5\%$ ($23 \pm 3^\circ\text{C}$)
 $\pm 0.6\%$ ($25 \pm 10^\circ\text{C}$)
 $\pm 0.9\%$ (0 to 55°C)

Frequency: 50 MHz nominal

SWR: 1.06 maximum
(1.08 maximum for Option 003)

Connector type: Type N (f), 50 $\frac{1}{2}$

Table 1

Model	ZERO SET
8481A, 8482A, 8483A, 8485A, 8487A, R8486A, Q8486A,	± 50 nW
8481B, 8482B	± 50 μ W
8481D, 8485D, 8487D	± 20 pW
8481H, 8482H	± 5 μ W
R8486D, Q8486D	± 30 pW
V8486A, W8486A	± 200 nW
E4412A, E4413A	± 50 pW
E9300A, E9301A, E9304A ²	± 500 pW
E9300B, E9301B ²	± 500 nW
E9300H, E9301H ²	± 5 nW

1. National metrology institutes of member states of the Metre Convention, such as the National Institute of Standards and Technology in the USA, are signatories to the Comité International des Poids et Mesures Mutual Recognition Arrangement. Further information is available from the Bureau International des Poids et Mesures, at <http://www.bipm.fr/>

2. Specification applies to the low power path 15% to 75% relative humidity.

Supplemental characteristics

Power reference

Frequency: 50 MHz nominal.

SWR: 1.05 maximum.

Connector: Type N (f), 50 ½.

Measurement speed

Three measurement speed modes, over the GPIB, are available as shown, along with the typical maximum measurement speed for each mode.

With the E4418B power meter

Normal: 20 readings/second

x2: 40 readings/second

Fast: 200 readings/second

With the E4419B, the measurement speed is reduced, for example, with both channels in FAST mode, the typical maximum measurement speed is 100 readings/second.

Fast mode is for E-series sensors only.

Maximum measurement speed is obtained using binary output and in free run trigger mode.

Zero drift of sensors: Sensor dependent, refer to table 2. For E9300 sensors, refer to table 12 for complete data.

Table 2

Model	Zero drift ¹	Measurement noise ²
8481A, 8482A, 8483A, 8485A, 8487A, R8486A, Q8486A	< ±10 nW	< 110 nW
8481B, 8482B	< ±10 µW	< 110 µW
8481D, 8485D, 8487D	< ±4 pW	< 45 pW
8481H, 8482H	< ±1µW	< 10 µW
R8486D, Q8486D	< ±6 pW	< 65 pW
V8486A, W8486A	< ±40 nW	< 450 nW
E4412A, E4413A	< ±15 pW	< 70 pW
E9300A, E9301A, E9304A ³	< ±150 pW	< 700 pW
E9300B, E9301B ³	< ±150 nW	< 700 nW
E9300H, E9301H ³	< ±1.5 nW	< 7 nW

1. Within 1 hour after zero set, at a constant temperature, after a 24-hour warm-up of the power meter.
2. The number of averages at 16 for normal mode and 32 for x2 mode, at a constant temperature, measured over a one minute interval and two standard deviations. For E-series sensors, the measurement noise is measured within the low range. Refer to the relevant sensor manual for further information.
3. Specification applies to the low power path, 15% to 75% relative humidity.

Measurement noise: Sensor dependent, refer to table 2 and table 3. For E9300 sensors, refer to table 12.

Example:

8481D power sensor, normal mode, number of averages = 4.

Effects of averaging on noise: Averaging over 1 to 1024 readings is available for reducing noise. Table 2 provides the measurement noise for a particular sensor with the number of averages set at 16 (for normal mode) and 32 (for x2 mode). Use the noise multiplier, for the appropriate mode (normal or x2) and number of averages, to determine the total measurement noise value.

Measurement noise calculation:

(< 45 pW x 2.75) = < 121 pW.

Table 3

Number of averages	1	2	4	8	16	32	64	128	256	512	1024
Noise multiplier (normal mode)	5.5	3.89	2.75	1.94	1	0.85	0.61	0.49	0.34	0.24	0.17
Noise multiplier (x2 mode)	6.5	4.6	3.25	2.3	1.63	1	0.72	0.57	0.41	0.29	0.2

With compliments

Helmut Singer Elektronik

www.helmut-singer.de info@helmut-singer.de
 fon +49 241 155 315 fax +49 241 152 066
 Feldchen 16-24 D-52070 Aachen Germany

EPM series E4418B and E4419B power meters

Settling time ¹

For 8480 series sensors:

Manual filter, 10 dB decreasing power step.

Table 4

Number of averages	1	2	4	8	16	32	64	128	256	512	1024
Settling time(s) (normal mode)	0.15	0.2	0.3	0.5	1.1	1.9	3.4	6.6	13	27	57
Settling time(s) (x2 modes)	0.15	0.18	0.22	0.35	0.55	1.1	1.9	3.5	6.9	14.5	33

Auto filter, default resolution, 10 dB decreasing power step (normal and x2 modes):

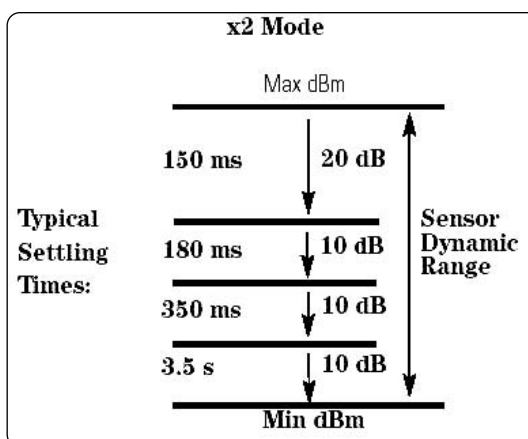
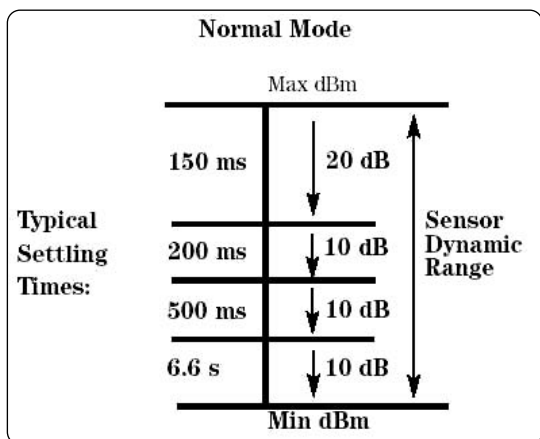

For E-series sensors:

In **FAST** mode (using free run trigger), within the range ± 50 dBm to +17 dBm, for a 10 dB decreasing power step, the settling time is:

E4418B: 10 ms²

E4419B: 20 ms²

Table 5. Manual filter, 10 dB decreasing power step (not across the range switch point)

Number of averages	1	2	4	8	16	32	64	128	256	512	1024
Settling time(s) (Normal mode)	0.07	0.12	0.21	0.4	1	1.8	3.3	6.5	13	27	57
Settling time(s)	0.04	0.07	0.12	0.21	0.4	1	1.8	3.4	6.8	14.2	32

1. Settling time: 0 to 99% settled readings over the GPIB

2. When a power step crosses through the sensor's auto-range switch point, add 25 mS. Refer to the relevant sensor manual for switch point information.

For E4412A and E4413A sensors
 Auto filter, default resolution, 10 dB
 decreasing power step (not across the
 range switch point)

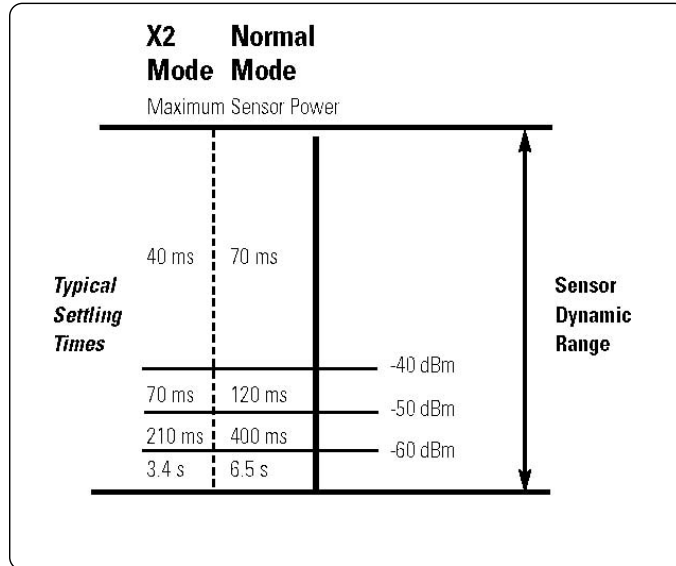

For E-series E9300A sensors

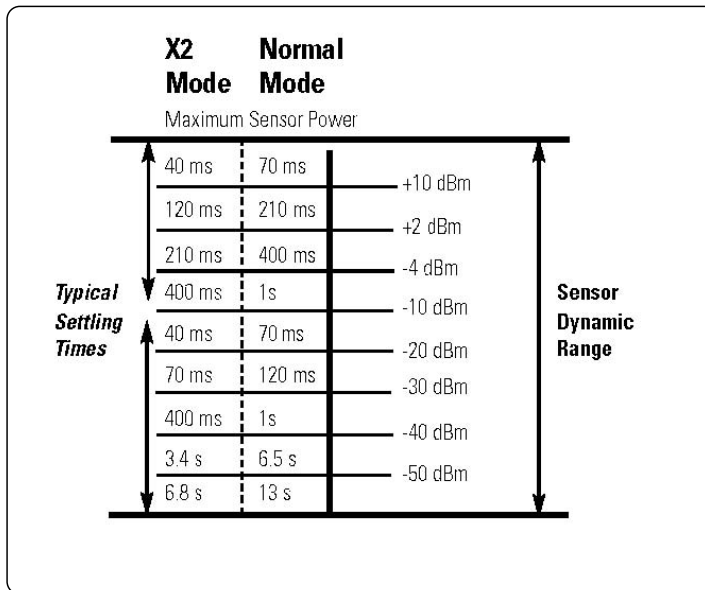

For E-series E9300B and H sensors

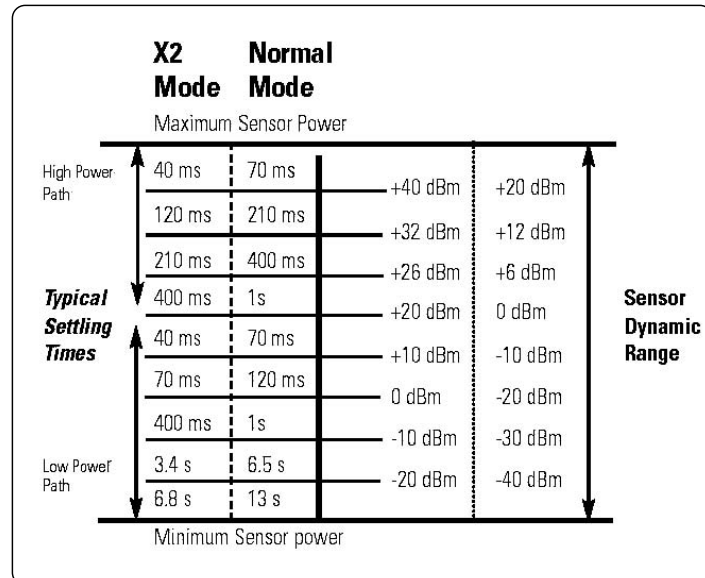

Power meter functions

Accessed by key entry: either hardkeys, or softkey menu, and programmable.

Zero: Zeros the meter. (Power reference calibrator is switched off during zeroing.)

Cal: Calibrates the meter using internal (power reference calibrator) or external source. Reference cal factor settable from 1% to 150%, in 0.1% increments.

Frequency: Entered frequency range is used to interpolate the calibration factors table.

Range: 1 kHz to 999.9 GHz, settable in 1 kHz steps.

Cal factor: Sets the calibration Factor for the meter. Range: 1% to 150%, in 0.1% increments.

Relative: Displays all successive measurements relative to the last displayed value.

Offset: Allows power measurements to be offset by ± 100 dB to +100 dB, settable in 0.001dB increments, to compensate for external loss or gain.

Save/recall: Store up to 10 instrument states via the save/recall menu.

dBm/W: Selectable units of either Watts or dBm in absolute power; or percent or dB for relative measurements.

Filter (averaging): Selectable from 1 to 1024. Auto-averaging provides automatic noise compensation.

Duty cycle: Duty cycle values between 0.001% to 99.999%, in 0.001% increments, can be entered to display a peak power representation of measured power. The following equation is used to calculate the displayed peak power value: peak power = measured power/dutycycle.

Sensor cal tables: Selects cal factor versus frequency tables corresponding to specified sensors (8480 series only).

Limits: High and low limits can be set in the range ± 150.000 dBm to ± 230.000 dBm, in 0.001 dBm increments.

Preset default values: dBm mode, rel off, power reference off, duty cycle off, offset off, frequency 50 MHz, AUTO average, free run, AUTO range (for E-series sensors).

Display: Selectable single and split screen formats are available. A quasi-analog display is available for peaking measurements. The dual channel power meter can simultaneously display any two configurations of A, B, A/B, B/A, A-B, B-A and relative.

General characteristics

Rear panel connectors

Recorder outputs: Analog 0 to 1 Volt, 1 k $\frac{1}{2}$ output impedance, BNC connector. E4419B recorder outputs are dedicated to channel A and channel B.

Remote input/output: A TTL logic level is output when the measurement exceeds a predetermined limit. TTL inputs are provided to initiate zero and calibration cycles. RJ-45 series shielded modular jack assembly connector. TTL Output: high = 4.8V max; low = 0.2V max TTL

Input: high = 3.5V min, 5V max; low = 1V max, -0.3V min.

GPIB: Allows communication with an external controller.

RS-232/442: Allows communication with an external RS-232 or RS-422 controller. Male/plug 9 position D-subminiature connector

Ground: Binding post, accepts 4 mm plug or bare-wire connection.

Line power

Input voltage range: 85 to 264 VAC, automatic selection.

Input frequency range: 50 to 440 Hz.

Power requirement: approximately 50 VA (14 Watts) for E4418B and E4419B.

With compliments

Helmut Singer Elektronik

www.helmut-singer.de info@helmut-singer.de
fon +49 241 155 315 fax +49 241 152 066
Feldchen 16-24 D-52070 Aachen Germany

Battery Option 001 operational characteristics¹

The following information describes characteristic performance based at a temperature of 25°C unless otherwise noted.

Typical operating time: up to 3.5 hours with LED backlight on; up to 5.5 hours with LED backlight off (E4418B power meter).

Charge time: 2 hours to charge fully from an empty state; 50 minutes charging enables 1 hour of operation with LED backlight on; 35 minutes charging enables 1hr operation with LED backlight off. Power meter is operational whilst charging.

Service life: (to 70% of initial capacity at 25°C): 450 charge/discharge cycles

Chemistry: nickel metal hydride

Weight: 1kg

Environmental characteristics

General conditions: Complies with the requirements of the EMC Directive 89/336/EEC. This includes Generic Immunity Standard EN 50082- 1: 1992 and Radiated Interference Standard EN 55011: 1991/CISPR11:1990, Group 1 - Class A.

Operating environment

Temperature: 0°C to 55°C.

Maximum humidity: 95% at 40°C (non- condensing).

Minimum humidity: 15% at 40°C (non- condensing).

Maximum altitude: 3000 meters (9840 feet).

Storage conditions

Storage temperature: -20°C to +70°C.

Non-operating maximum humidity: 90% at 65°C (non- condensing).

Non-operating maximum altitude: 15240 meters (50,000 feet).

General

Dimensions: The following dimensions exclude front and rear protrusions.

212.6 mm W x 88.5 mm H x 348.3 mm D
(8.5 in x 3.5 in x 13.7 in)

Weight

Net: E4418B: 4.0 kg (8.8 lb).

E4419B: 4.1 kg (9.0 lb).

Shipping:

E4418B: 7.9 kg (17.4 lb).

E4419B: 8.0 kg (17.6 lb).

Remote programming

Interface: GBIB interface operates to IEEE 488.2. RS- 232 and RS- 422 serial interface supplied as standard.

Command language: SCPI standard interface commands. 436A and 437B code compatible (E4418B only); 438A code compatible (E4419B only).

GPIO compatibility: SH1, AH1, T6, TE0, L4, LE0, SR1, RL1, PP1, DC1, DT1, C0.

Non-volatile memory

Battery: Lithium polycarbon Monoflouride, approximate lifetime 5 years at 25°C.

Safety

Conforms to the following product specifications:

EN61010-1: 1993/IEC 1010- 1: 1990 +A1/CSA C22.2 No. 1010- 1: 1993

EN60825-1: 1994/IEC 825- 1: 1993 Class 1 Low Voltage Directive 72/23/EEC

Accessories supplied

Power sensor cable

11730A: E4418B has one 1.5 meter (5 ft) sensor cable. E4419B has two 1.5 meter (5 ft) sensor cables.

Power cord: One 2.4 meter (7.5 ft) cable. Power plug matches destination requirements.

1. Characteristics describe product performance that is useful in the application of the product, but is not covered by the product warranty.

EPM series power meters

E4418B: Single channel EPM series power meter

E4419B: Dual channel EPM series power meter

Options available

Power

Option E441xB-001: Mains power and internal rechargeable battery

Connectors

Option E441xB-002: Parallel rear panel sensor input connector(s) and front panel reference calibrator connector

Option E441xB-003: Parallel rear panel sensor input connectors and rear panel reference calibrator connector

Calibration documentation

Option E441xB-A6J: ANSI Z540 compliant calibration test data including measurement uncertainties

Option E441xB-1A7: ISO17025 compliant calibration test data including measurement uncertainties

Documentation

A hard copy and CD version of the English language User's Guide and Programming Guide is provided with the EPM power meter as standard. A selection can be made to delete the hard copy

Option E441xB-0B0: Delete manual set

Additional documentation

Selections can be made for the localization of the User's Guide, and an English language Service Manual

Option E441xB-915: English language Service Manual

Option E441xB-916: English language manual set (hard copy Users Guide and Programming Guide)

Option E441xB-ABD: German localization (hard copy Users Guide and English Programming Guide)

Option E441xB-ABE: Spanish localization (hard copy Users Guide and English Programming Guide)

Option E441xB-ABF: French localization (hard copy Users Guide and English Programming Guide)

Option E441xB-ABJ: Japanese localization (hard copy Users Guide and English Programming Guide)

Cables

Option E441xB-004: Delete power sensor cable

Additional cables

11730A: Power sensor and SNS noise source cable, length 1.5 meters (5 ft)

11730B: Power sensor and SNS noise source cable, length 3 meters (10 ft)

11730C: Power sensor and SNS noise source cable, length 6.1 meters (20 ft)

11730D: Power sensor cable, length 15.2 meters (50 ft)

11730E: Power sensor cable, length 30.5 meters (100 ft)

11730F: Power sensor cable, length 61 meters (200 ft)

Accessories

Option E441xB-908: Rackmount kit (one instrument)

Option E441xB-909: Rackmount kit (two instruments)

34131A: Transit case for half-rack 2U high instruments

34141A: Yellow soft carry/operating case

34161A: Accessory pouch

E9287A¹: Spare battery pack for the EPM power meter

Complementary equipment

11683A: Range calibrator

Verifies the accuracy and linearity of the EPM series power meters. Outputs corresponding to meter readings of 3, 10, 30, 100 and 300 μ W and 1, 3, 10, 30 and 100 mW are provided. Calibration uncertainty is $\pm 0.25\%$ on all ranges.

Service options

Warranty

Included with each EPM series power meter² is a standard 12 month return to Agilent warranty and service plan. For an extension of the initial warranty and service plan to 3 years, order the option below.

R-51B-001-3C: Return-to-Agilent warranty and service plan

Calibration³

For 3 years, order 36 months of the appropriate calibration plan shown below.

R-50C-001-3: Standard calibration plan

R-50C-021-3 Z540 calibration plan

The E-series and 8480 series power sensors have a 12 months return to Agilent warranty and service plan. For more information, contact your local sales and service office.

1. Only for EPM series power meter with Option E441xB-001 installed.
2. For Option E441xB-001, the 36 month warranty does not apply to the E9287A battery pack.
3. Options not available in all countries.

With compliments

Helmut Singer Elektronik

www.helmut-singer.de info@helmut-singer.de
fon +49 241 155 315 fax +49 241 152 066
Feldchen 16-24 D-52070 Aachen Germany

E-series power sensor specifications

The E-series of power sensors have their calibration factors stored in EEPROM and operate over a wide dynamic range. They are designed for use with the EPM series of power meters and two classes of sensors are available:

¥ CW power sensors (E4412A and E4413A).

¥ Average power sensors (E9300 sensors).

E-series CW power sensor specifications

Wide dynamic range CW sensors: 100 pW to 100 mW (-70 dBm to +20 dBm)

Table 6

Model	Frequency range	Maximum SWR	Maximum power	Connector type
E4412A	10 MHz – 18 GHz	*10 MHz to 30 MHz: 1.12	200 mW (+23 dBm)	Type-N (m)
		30 MHz to 2 GHz:1.15		
		2 GHz to 6 GHz:1.17		
		6 GHz to 11 GHz:1.2		
E4413A	50 MHz – 26.5 GHz	11 GHz to 18 GHz:1.27	200 mW (+23 dBm)	APC-3.5mm (m)
		50 MHz to 100 MHz: 1.21		
		100 MHz to 8 GHz:1.19		
		8 GHz to 18 GHz:1.21		
		18 GHz to 26.5 GHz:1.26		

* Applies to sensors with serial prefix US 3848 or greater

Power linearity

Table 7

Power	Temperature (25°C ±5°C)	Temperature (0° to 55°C)
100 pW to 10 mW (-70 dBm to +10 dBm)	±3 %	±7 %
10 mW to 100 mW (+10 dBm to +20 dBm)	±4.5%	±10%

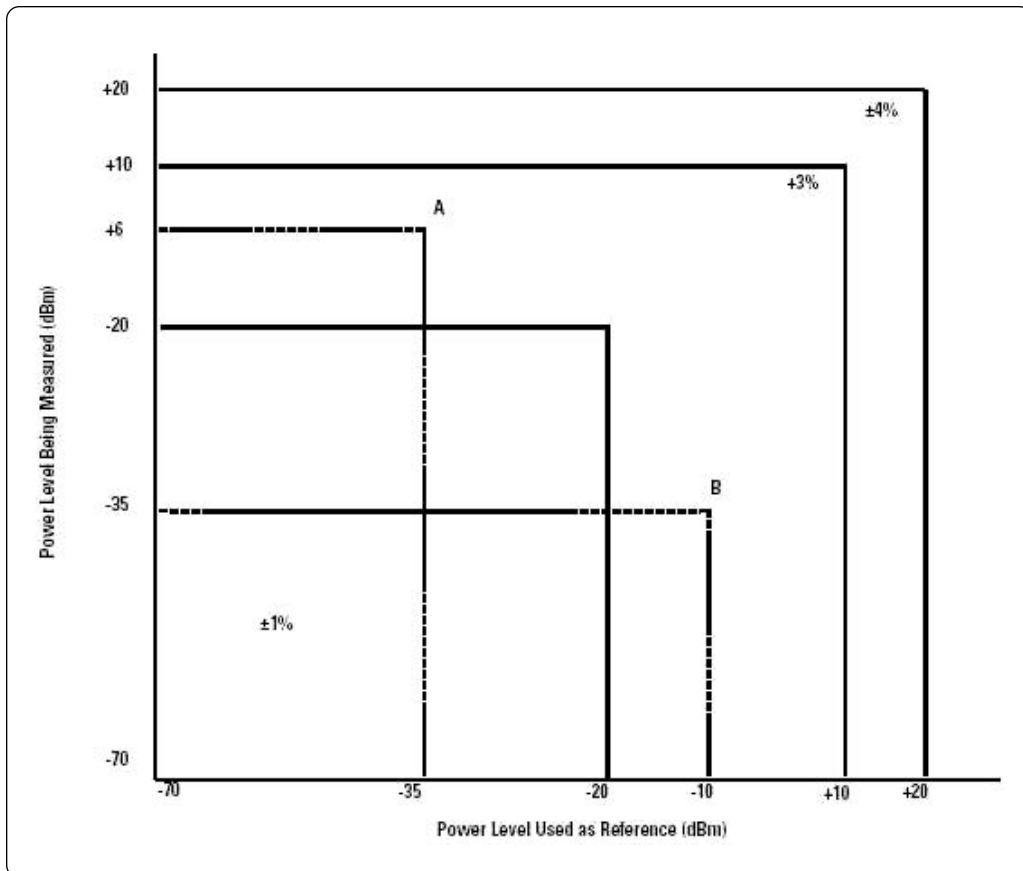

Figure 1 : Relative mode power measurement linearity with EPM series power meter/E-series CW power sensor at 25°C ± 5°C (typical)

The chart in figure 1 shows the typical uncertainty in making a relative power measurement, using the same power meter channel and the same power sensor to obtain the reference and the measured values. Example A illustrates a relative gain (amplifier measurement). Example B illustrates a relative loss (insertion loss measurement). This chart assumes negligible change in frequency and mismatch occur when transitioning from the power level used as the reference to the power level being measured.

Example A:

$P = 10(P)/10 \times 1 \text{ mW}$
 $P = 10 \text{ 6}/10 \times 1 \text{ mW}$
 $P = 3.98 \text{ mW}$
 $3\% \times 3.98 \text{ mW} = 119.4 \text{ }\mu\text{W}$
 (where P = power in Watts, and (P) = power in dBm)

Example B:

$P = 10 (P)/10 \times 1 \text{ mW}$
 $P = 10 - 35/10 \times 1 \text{ mW}$
 $P = 316 \text{ nW}$
 $3\% \times 316 \text{ nW} = 9.48 \text{ nW}$

General

Dimensions:

E4412A:
 130 mm L x 38 mm W x 30 mm H
 (5.1 in x 1.5 in x 1.2 in)

E4413A:
 102 mm L x 38 mm W x 30 mm H
 (4 in x 1.5 in x 1.2 in)

Weight:

E4412A: 0.18 kg (0.4 lb).
 E4413A: 0.18 kg (0.4 lb).

Calibration factor (CF) and reflection coefficient (Rho)

Calibration factor and reflection coefficient data are provided at 1 GHz increments on a data sheet included with the power sensor. This data is unique to each sensor. If you have more than one sensor, match the serial number on the data sheet with the serial number on the power sensor you are using. The CF corrects for the frequency response of the sensor. The EPM power meter automatically reads the CF data stored in the sensor and uses it to make the corrections. For power levels greater than 0 dBm, add 0.5%/dB to the calibration factor uncertainty specification.

Reflection coefficient (Rho) relates to the SWR according to the following formula: $SWR = 1 + Rho/1 - Rho$

Maximum uncertainties of the CF data are listed in table 8a, for the E4412A power sensor, and table 8b for the E4413A power sensor. The uncertainty analysis for the calibration of the sensors was done in accordance with the ISO/TAG4 Guide. The uncertainty data reported on the calibration certificate is the expanded uncertainty with a 95% confidence level and a coverage factor of 2.

Table 8a. E4412A calibration factor uncertainty at 1 mW (0 dBm)

Frequency	Uncertainty (%)
10 MHz	1.8
30 MHz	1.8
50 MHz	Reference
100 MHz	1.8
1.0 GHz	1.8
2.0 GHz	2.4
4.0 GHz	2.4
6.0 GHz	2.4
8.0 GHz	2.4
10.0 GHz	2.4
11.0 GHz	2.4
12.0 GHz	2.4
14.0 GHz	2.4
16.0 GHz	2.6
18.0 GHz	2.6

Table 8b. E4413A calibration factor uncertainty at 1 mW (0 dBm)

Frequency	Uncertainty (%)
50 MHz	Reference
100 MHz	1.8
1.0 GHz	1.8
2.0 GHz	2.4
4.0 GHz	2.4
6.0 GHz	2.4
8.0 GHz	2.4
10.0 GHz	2.6
11.0 GHz	2.6
12.0 GHz	2.8
14.0 GHz	2.8
16.0 GHz	2.8
17.0 GHz	2.8
18.0 GHz	2.8
20.0 GHz	3
22.0 GHz	3
24.0 GHz	3
26.0 GHz	3
28.0 GHz	3

With compliments
Helmut Singer Elektronik
 www.helmut-singer.de info@helmut-singer.de
 fon +49 241 155 315 fax +49 241 152 066
 Feldchen 16-24 D-52070 Aachen Germany

E-series E9300 average power sensor specifications

The E-series E9300 wide dynamic range, average power sensors are designed for use with the EPM family of power meters. These specifications are valid ONLY after proper calibration of the power meter and apply for CW signals unless otherwise stated.

Specifications apply over the temperature range 0°C to 55°C unless otherwise stated, and specifications quoted over the temperature range 25°C ±10°C, conform to the standard environmental test conditions as defined in TIA/EIA/IS-97-A and TIA/EIA/IS-98-A [1].

The E-series E9300 power sensors have two independent measurement paths (high and low power paths):

High power path: -10 to +20 dBm ("A" suffix sensors), +20 to +44 dBm ("B" suffix sensors) and 0 to +30 dBm ("H" suffix sensors).

Low power path: -60 to -10 dBm ("A" suffix sensors), -30 to +20 dBm ("B" suffix sensors) and -50 to 0 dBm ("H" suffix sensors).

Some specifications are detailed for an individual measurement path.

Table 9
Wide dynamic range (-60 to +20 dBm) sensors

Model	Frequency range	Maximum SWR (25°C ± 10°C)	Maximum SWR (0 – 55°C)	Maximum power	Connector type
E9300B	10 MHz – 18.0 GHz	10 MHz to 30 MHz: 1.15 30 MHz to 2 GHz: 1.13 2 GHz to 14 GHz: 1.19 14 GHz to 16 GHz: 1.22 16 GHz to 18 GHz: 1.26	10 MHz to 30 MHz: 1.21 30 MHz to 2 GHz: 1.15 2 GHz to 14 GHz: 1.20 14 GHz to 16 GHz: 1.23 16 GHz to 18 GHz: 1.27	+25 dBm average; +33 dBm peak (< 10 µsec)	Type-N (m)
E9301A	10 MHz – 6.0 GHz	10 MHz to 30 GHz: 1.15 30 MHz to 2 GHz: 1.13 2 GHz to 14 GHz: 1.19	10 MHz to 30 MHz: 1.21 30 MHz to 2 GHz: 1.15 2 GHz to 14 GHz: 1.20	+25 dBm average; +33 dBm peak (< 10 µsec)	Type-N (m)
E9304A	9 kHz – 6.0 GHz	9 kHz to 2 GHz: 1.13 2 GHz to 6 GHz: 1.19	9 kHz to 2 GHz: 1.15 2 GHz to 6 GHz: 1.20	+25 dBm average; +33 dBm peak (< 10 µsec)	Type-N (m)

Wide dynamic range (-30 to +44 dBm) sensors

Model	Frequency range	Maximum SWR (25°C ± 10°C)	Maximum SWR (0 – 55°C)	Maximum power	Connector type
E9300B	10 MHz – 18.0 GHz	10 MHz to 8 GHz: 1.12 8 to 12.4 GHz: 1.17 12.4 to 18 GHz: 1.24	10 MHz to 8 GHz: 1.14 8 to 12.4 GHz: 1.18 12.4 to 18 GHz: 1.25	0 – 35°C: 30 W avg 35 – 55°C: 25 W avg < 6 GHz: 500 W pk > 6 GHz: 125 W pk 500 W-mS per pulse	Type-N (m)
E9301B	10 MHz – 6.0 GHz	10 MHz to 6 GHz: 1.12	10 MHz to 6 GHz: 1.14	0 – 35°C: 30 W avg 35 – 55°C: 25 W avg < 6 GHz: 500 W pk 500 W-mS per pulse	Type-N (m)

Wide dynamic range (-50 to +30 dBm) sensors

Model	Frequency range	Maximum SWR (25°C ± 10°C)	Maximum SWR (0 – 55°C)	Maximum power	Connector type
E9300H	10 MHz – 18.0 GHz	10 MHz to 8 GHz: 1.15 8 to 12.4 GHz: 1.25 12.4 to 18 GHz: 1.28	10 MHz to 8 GHz: 1.17 8 to 12.4 GHz: 1.26 12.4 to 18 GHz: 1.29	3.16 W avg 100 W pk 100 W-µS per pulse	Type-N (m)
E9301H	10 MHz – 6.0 GHz	10 MHz to 6 GHz: 1.15	10 MHz to 6 GHz: 1.17	3.16 W avg 100 W pk 100 W-µS per pulse	Type-N (m)

Typical SWR, 10 MHz to 18 GHz, (25°C ± 10°C) for E9300A and E9301A sensors

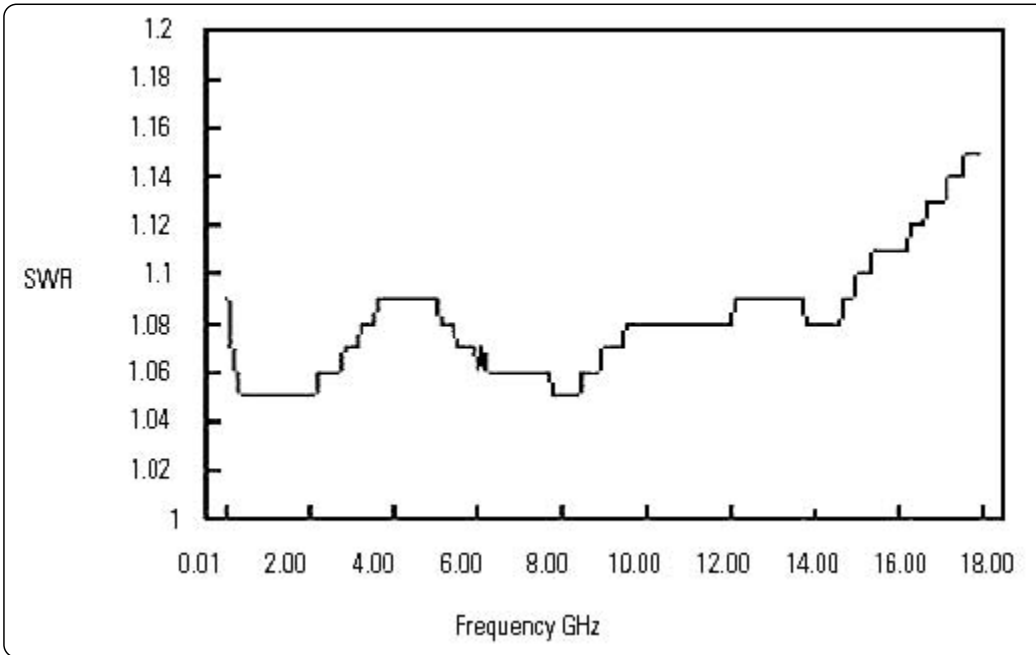

Typical SWR, 9kHz to 6 GHz, (25°C ± 10°C) for E9304A sensors

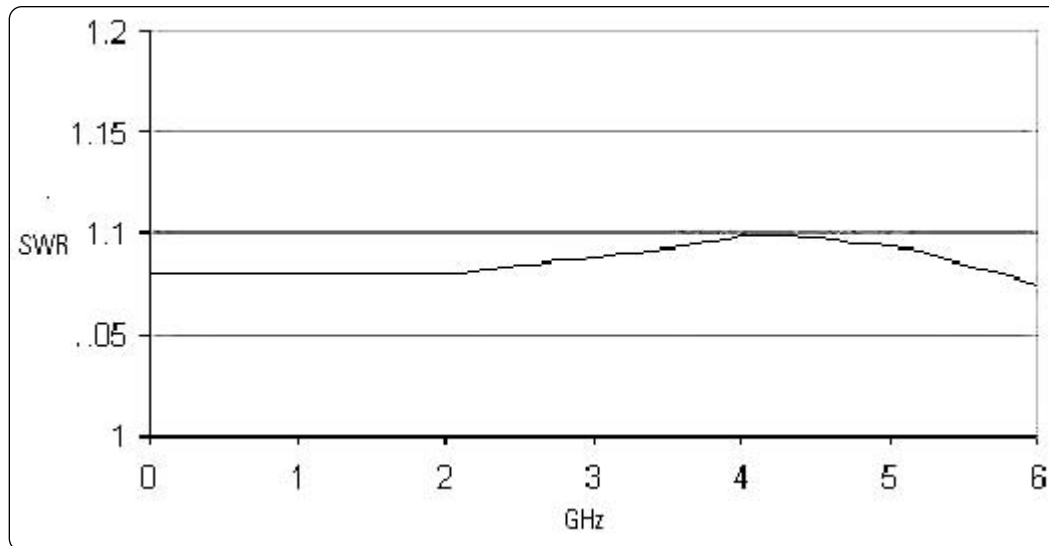

With compliments

Helmut Singer Elektronik

www.helmut-singer.de info@helmut-singer.de

fon +49 241 155 315 fax +49 241 152 066

Feldchen 16-24 D-52070 Aachen Germany

Typical SWR, 10 MHz to 18 GHz, (25°C ± 10°C) for E9300B and E9301B sensors

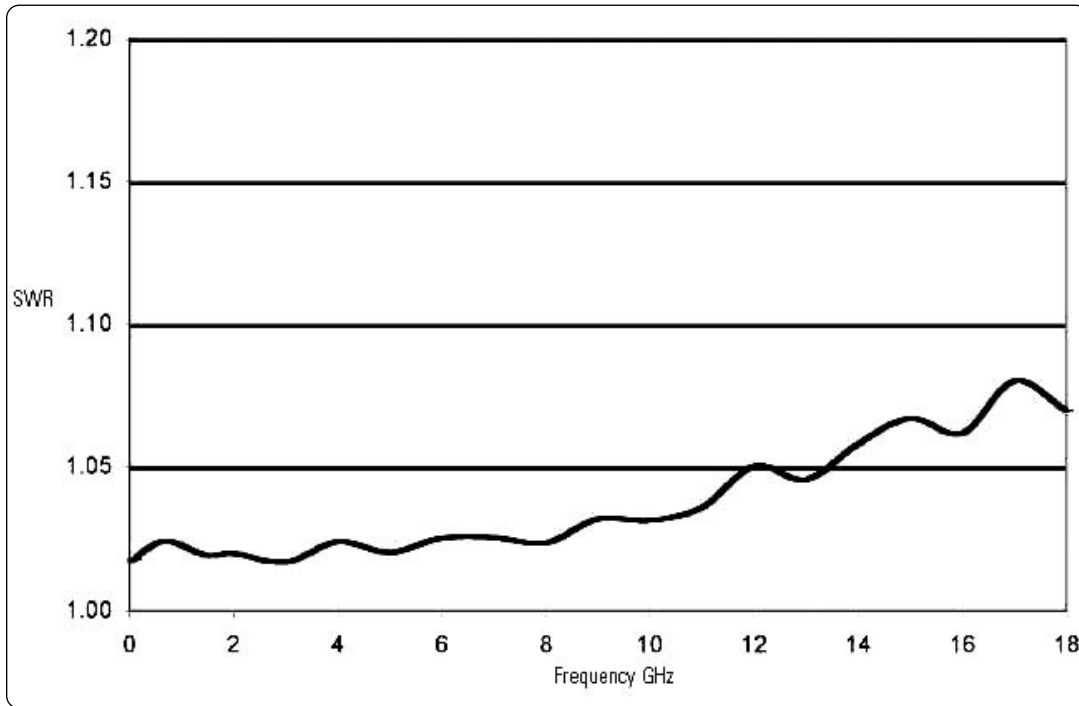

Typical SWR, 10 MHz to 18 GHz, (25°C ± 10°C) for E9300H and E9301H sensors

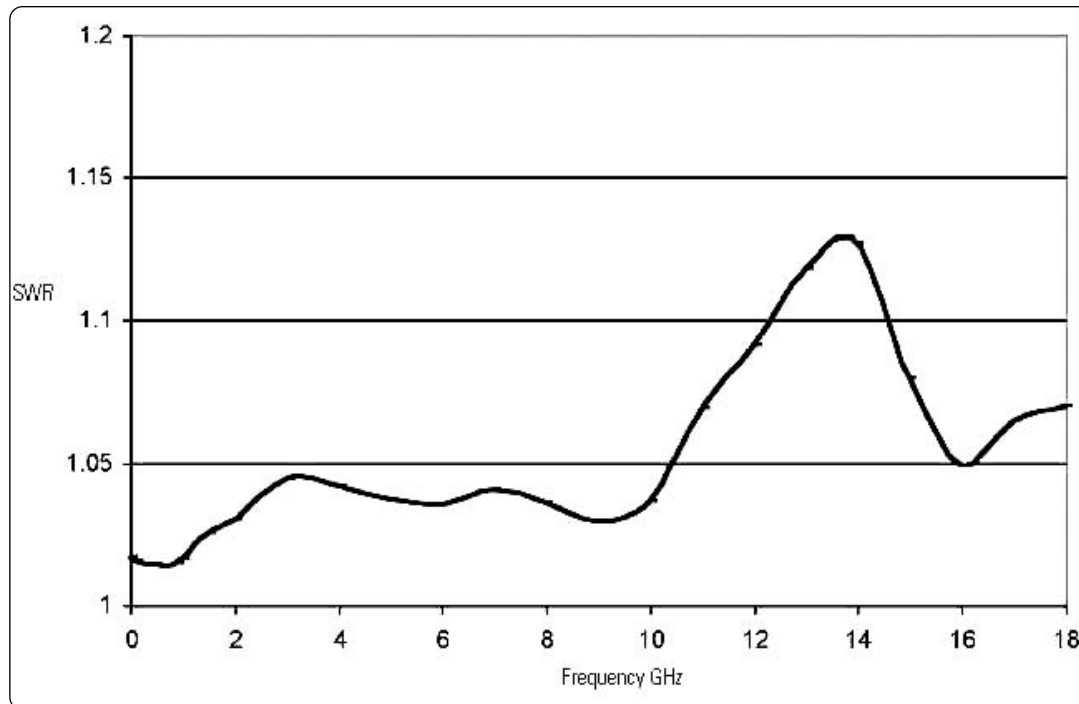

E-series E9300 average power sensors

Table 10. Power linearity (after zero and cal at ambient environmental conditions)

Sensor	Power	Linearity (25°C ± 10°C)	Linearity (0 – 55°C)
E9300A, E9301A, E9304A	-60 to -10 dBm	±3.0%	±3.5%
	-10 to 0 dBm	±2.5%	±3.0%
	0 to +20 dBm	±2.0%	±2.5%
E9300B, E9301B	-30 to +20 dBm	±3.5%	±4.0%
	+20 to +30 dBm	±3.0%	±3.5%
	+30 to +44 dBm	±2.5%	±3.0%
E9300H, E9301H	-50 to 0 dBm	±4.0%	±5.0%
	0 to +10 dBm	±3.5%	±4.0%
	+10 to +30 dBm	±3.0%	±3.5%

Typical E9300A/01A/04A Power Linearity at 25°C, after zero and calibration, with associated measurement uncertainty

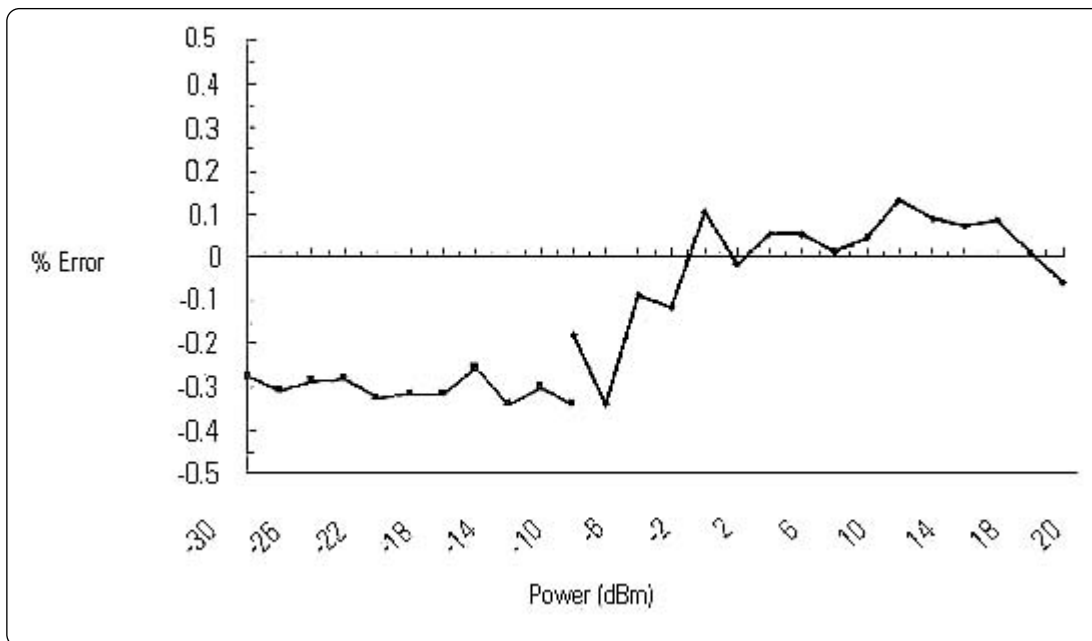

Power range	-30 to -20 dBm	-20 to -10 dBm	-10 to 0 dBm	0 to +10 dBm	+10 to +20 dBm
Measurement uncertainty	±0.9%	±0.8%	±0.65%	±0.55%	±0.45%

With compliments

Helmut Singer Elektronik

www.helmut-singer.de info@helmut-singer.de
 fon +49 241 155 315 fax +49 241 152 066
 Feldchen 16-24 D-52070 Aachen Germany

E-series E9300 average power sensors

Typical E9300B/01B power linearity at 25°C, after zero and calibration, with associated measurement uncertainty

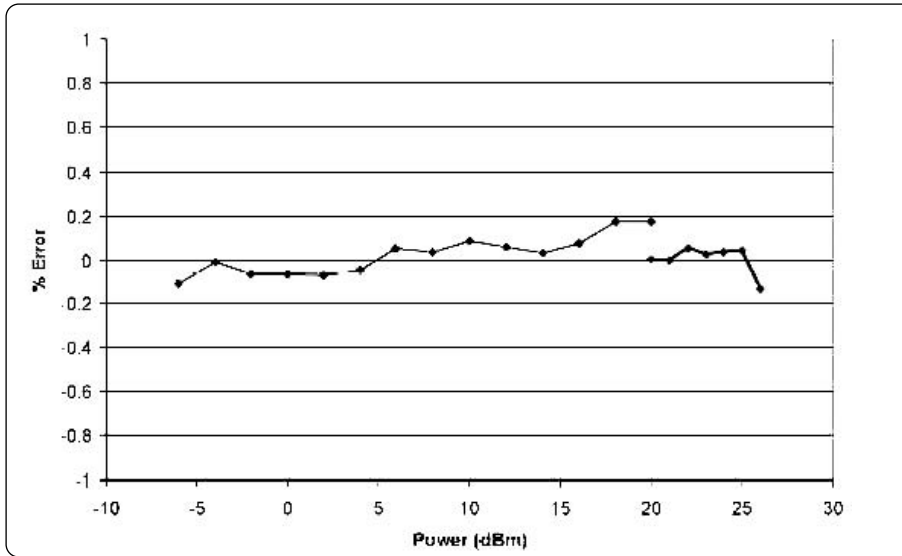

Power range	-6 to 0 dBm	0 to +10 dBm	+10 to +20 dBm	+20 to +26 dBm
Measurement uncertainty	± 0.65%	± 0.55%	± 0.45%	± 0.31%

Typical E9300H/01H power linearity at 25°C, after zero and calibration, with associated measurement uncertainty

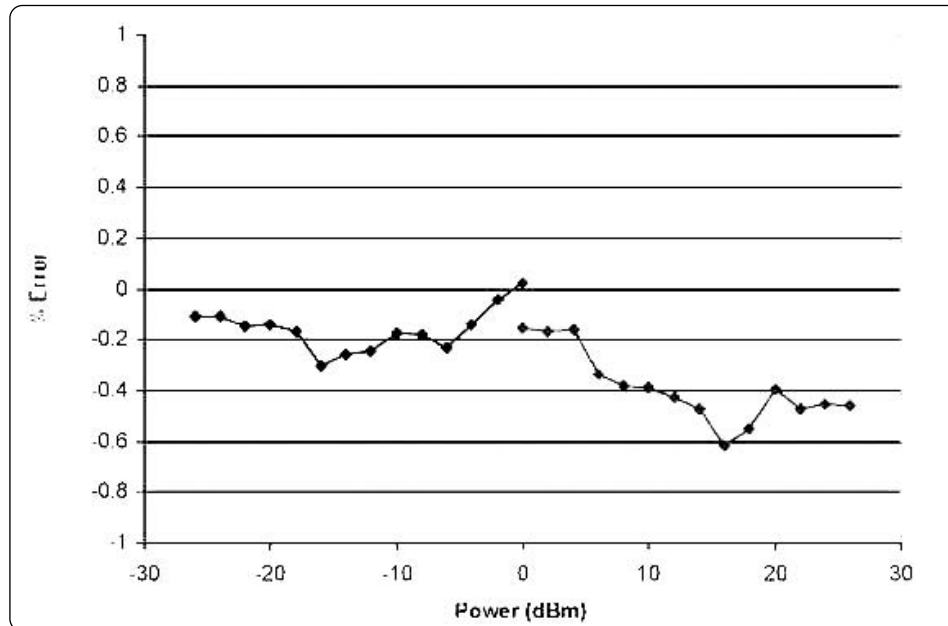

Power range	-26 to -20 dBm	-20 to -10 dBm	-10 to 0 dBm	0 to +10 dBm	+10 to +20 dBm	+20 to +26 dBm
Measurement uncertainty	± 0.9%	± 0.8%	± 0.65%	± 0.55%	± 0.45%	± 0.31%

Note: If the temperature changes after calibration and you choose not to re-calibrate the sensor, the following additional power linearity error should be added to the linearity specs in table 10: the typical maximum additional power linearity error due to temperature change after calibration, for small changes in temperature, is $\pm 0.15\%/^{\circ}\text{C}$ (valid after zeroing the sensor).

For large changes in temperature, refer to Table 11.

Typical maximum additional power linearity error due to temperature change after calibration at 25°C for any change in temperature (valid after zeroing the sensor)

Table 11

Sensor	Power	Additional power linearity error (25°C ± 10°C)	Additional power linearity error (0 – 55°C)
E9300A, E9301A, E9304A	-60 to -10 dBm	±1.5%	±2.0%
	-10 to 0 dBm	±1.5%	±2.5%
	0 to +20 dBm	±1.5%	±2.0%
E9300B, E9301B	-30 to +20 dBm	±1.5%	±2.0%
	+20 to +30 dBm	±1.5%	±2.5%
	+30 to +44 dBm	±1.5%	±2.0%
E9300H, E9301H	-50 to 0 dBm	±1.5%	±2.0%
	0 to +10 dBm	±1.5%	±2.5%
	+10 to 30 dBm	±1.5%	±2.0%

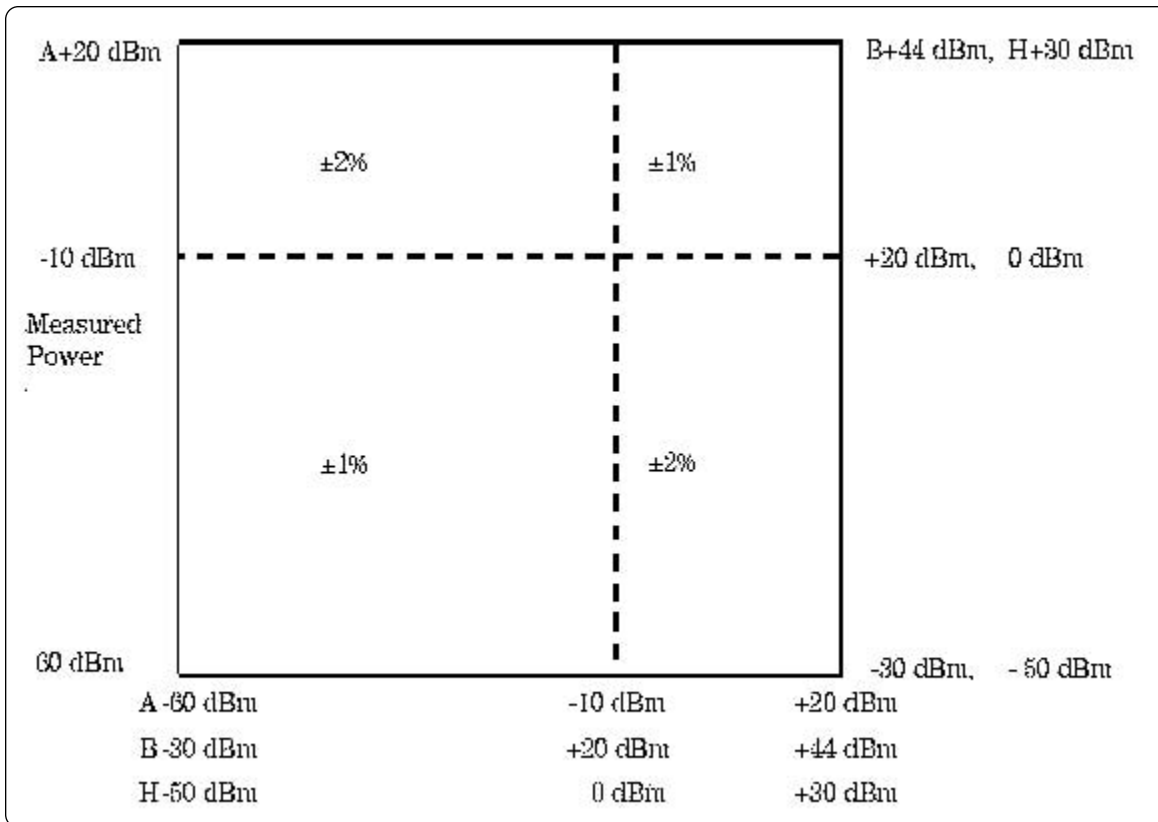

Figure 2. Relative mode power measurement linearity with an EPM series power meter, at 25°C ±10°C (typical)

Figure 2 shows the typical uncertainty in making a relative power measurement, using the same power meter channel and same power sensor to obtain the reference and the measured values, and assumes that negligible change in frequency and mismatch error occur when transitioning from the power level used as the reference to the power level being measured.

With compliments
Helmut Singer Elektronik
 www.helmut-singer.de info@helmut-singer.de
 fon +49 241 155 315 fax +49 241 152 066
 Feldchen 16-24 D-52070 Aachen Germany

E-series E9300 average power sensors

Switch point data

The E9300 power sensors have two paths, a low power path covers: -60 to -10 dBm (0A suffix sensors), -30 to +20 dBm (0B suffix sensors), and -50 to 0 dBm (0H suffix sensors). The high power path covers: -10 to +20 dBm (0A suffix sensors), +20 to +44 dBm (0B suffix sensors), and 0 to +30 dBm (0H suffix sensors). The power meter automatically selects the proper power level path. To avoid unnecessary switching when the power level is near the switch point, switching point hysteresis has been added.

E9300 0A suffix sensors example: hysteresis causes the low power path to remain selected until approximately -9.5 dBm as the power level is increased, above this power the high power path will be selected. The high power path will remain selected until approximately -10.5 dBm is reached as the signal level decreases, below this power the low power path will be selected.

Switching point linearity: *Typically*
 $\pm 0.5\%$ (± 0.02 dB)

Switching point hysteresis: *0.5 dB typical*

Table 12. E9300A, E9301A, and E9304A sensors zero and measurement noise

Conditions ¹	Zero set	Zero drift ²	Measurement noise ³
Low power path (15% to 75% RH)	500 pW	150 pW	700 pW
Low power path (75% to 95% RH)	500 pW	4,000 pW	700 pW
High power path (15% to 75% RH)	500 nW	150 nW	500 nW
High power path (75% to 95% RH)	500 nW	3 nW	500 nW

E9300B and E9301B sensors

Conditions ¹	Zero set	Zero drift ²	Measurement noise ³
Low power path (15% to 75% RH)	500 nW	150 nW	700 nW
Low power path (75% to 95% RH)	500 nW	4 μ W	700 nW
High power path (15% to 75% RH)	500 μ W	150 μ W	500 μ W
High power path (75% to 95% RH)	500 μ W	3 mW	500 μ W

E9300H and E9301H sensors

Conditions ¹	Zero set	Zero drift ²	Measurement noise ³
Low power path (15% to 75% RH)	5 nW	1.5 nW	7 nW
Low power path (75% to 95% RH)	5 nW	40 nW	7 nW
High power path (15% to 75% RH)	5 μ W	1.5 μ W	5 μ W
High power path (75% to 95% RH)	5 μ W	30 μ W	5 μ W

1. RH is the abbreviation for relative humidity.
2. Within 1 hour after zero set, at a constant temperature, after a 24-hour warm-up of the power meter with power sensor connected.
3. The number of averages at 16 for normal mode and 32 for x2 mode, at a constant temperature, measured over a one minute interval and two standard deviations.

With compliments

Helmut Singer Elektronik

www.helmut-singer.de info@helmut-singer.de
 fon +49 241 155 315 fax +49 241 152 066
 Feldchen 16-24 D-52070 Aachen Germany

Calibration factor (CF) and reflection coefficient (Rho)

Calibration factor and reflection coefficient data are provided at frequency intervals on a data sheet included with the power sensor. This data is unique to each sensor. If you have more than one sensor, match the serial number on the data sheet with the serial number on the power sensor you are using. The CF corrects for the frequency response of the sensor. The EPM series power meter automatically reads the CF data stored in the sensor and uses it to make the corrections.

Reflection coefficient (Rho) relates to the SWR according to the following formula:

$$SWR = (1 + \text{Rho}) / (1 - \text{Rho})$$

Maximum uncertainties of the CF data are listed in tables 13A and 13B. As the E-series E9300 power sensors have two independent measurement paths (high and low power paths), there are two calibration factor uncertainty tables. The uncertainty analysis for the calibration of the sensors was done in accordance with the ISO Guide. The uncertainty data reported on the calibration certificate is the expanded uncertainty with a 95% confidence level and a coverage factor of 2.

General

Dimensions: Length 130 mm, width 38 mm, height 30 mm

Weight: 0.18 kg (0.4 lbs)

References:

[1] TIA is the Telecommunications Industry Association; EIA is the Electronic Industries Association. TIA/EIA/IS-97-A is the recommended minimum performance standards for base stations supporting dual-mode wideband spread spectrum cellular mobile stations. TIA/EIA/IS-98-A is the recommended minimum performance standards for dual-mode wideband spread spectrum cellular mobile stations.

Table 13A. Calibration factor uncertainties (low power path)

Frequency	Uncertainty (%) (25°C +10°C)	Uncertainty (%) (0° to 55°C)
10 MHz to 30 MHz	± 1.8%	±2.2%
30 MHz to 500 MHz (E9304A: 9kHz to 500MHz)	±1.6%	±2.0%
500 MHz to 1.2 GHz	±1.8%	±2.5%
1.2 GHz to 6 GHz	±1.7%	±2.0%
6 GHz to 14 GHz	±1.8%	
14 GHz to 18 GHz ± 2.0 %	±2.0%	±2.2%

Table 13B Calibration factor uncertainties (high power path)

Frequency	Uncertainty (%) (25°C +10°C)	Uncertainty (%) (0° to 55°C)
10 MHz to 30 MHz	±2.1%	±4.0%
30 MHz to 500 MHz (E9304A: 9kHz to 500MHz)	±1.8%	±3.0%
500 MHz to 1.2 GHz	±2.3%	±4.0%
1.2 GHz to 6 GHz	±1.8%	±2.1%
6 GHz to 14 GHz	±1.9%	±2.3%
14 GHz to 18 GHz	±2.2%	±3.3%

8480 series power sensors (with EPM series power meters)

The 8480 series power sensors are designed for use with the 435B, 436A, 437B, 438A, 70100A, E1416A and now the E4418B and E4419B power meters. These thermocouple and diode power sensors provide extraordinary accuracy, stability, and SWR over a wide range of frequencies (100 kHz to 110 GHz) and power levels - 70 dBm to +44 dBm).

Table 14. Typical Root sum of squares (rss) uncertainty on the calibration factor data printed on the power sensor

Freq (MHz)	8482A	8482B	8482H	8483A
0.1	1.3	2.8	1.6	1.5
0.3	1.2	2.8	1.6	1.4
1	1.2	2.8	1.6	1.4
3	1.2	2.8	1.6	1.4
10	1.3	2.8	1.6	1.6
30	1.4	2.8	1.7	1.6
50	0 (ref)	2.7	0 (ref)	0 (ref)
100	1.6	3.3	1.9	2
300	1.6	3.3	1.9	2
1000	1.4	3.3	1.7	2
2000	1.4	3.3	1.7	2.1
4000	1.5	3.1	1.8	-

Freq (GHz)	8481A	8481B	8481H	8481D	8485A	8385D	8487A	8487D
1	1.6	3	1.9	1.9	1.6	1.8	1.6	2
2	1.4	3.1	1.7	1.8	1.6	1.8	1.6	2
4	1.5	3.1	1.8	1.8	1.7	1.8	1.6	2
6	1.5	3.1	1.8	1.8	1.8	2.1	1.7	2.3
8	1.7	3.2	2	2	1.9	2.2	1.8	2.3
10	1.9	3.3	2.2	2.2	2	2.1	1.8	2.3
12	2.1	4.1	2.4	2.8	2	2.2	1.9	2.3
14	2.6	4.1	2.8	3.2	2.2	2.2	2.1	2.8
16	2.9	4.2	3	3.4	2.3	2.5	2.2	2.8
18	3.2	4.3	3.1	3.7	2	2.6	2.3	2.8
22	-	-	-	-	2.1	2	1.8	2.8
26.5	-	-	-	-	2.1	2.3	2.1	2.8

Freq (GHz)	R8486A	Q8486A	R8486D	Q8486D	8487A	8487D
26.5	2.2	-	3	-	2.1	2.8
28	2.4	-	3.2	-	2.3	3
30	2.5	-	3	-	2.1	3
33	2.1	2.8	3	4.2	2.3	3
34.5	2.1	2.8	3	4.2	2.1	3
37	2.2	2.8	3	4.2	2.3	3
40	2.2	2.9	3	4.2	2.6	3
42	-	3.9	-	4.9	3.2	2.9
44	-	3.9	-	5.1	3.6	2.9
46	-	3.9	-	5.5	4.1	3.1
48	-	4.9	-	5.8	4.5	4.5
50	-	5.3	-	6.2	5	4.5

With compliments

Helmut Singer Elektronik

www.helmut-singer.de info@helmut-singer.de
fon +49 241 155 315 fax +49 241 152 066
Feldchen 16-24 D-52070 Aachen Germany

8480 series sensors (with EPM series power meters)

Table 15

25 Watt sensors, 1 mW to 25 W (0 dBm to +44 dBm)

Model	Frequency range	Maximum SWR	Power linearity ¹	Maximum power	Connector type	Weight
8481B	10 MHz to 18 GHz	10 MHz to 2 GHz: 1.10 2 GHz to 12.4 GHz: 1.18 12.4 GHz to 18 GHz: 1.28	+35 dBm to + 44 dBm: (±4%)	0°C to 350°C: 30W avg ² 35°C to 550°C: 25W avg 0.01 to 5.8 GHz: 500W pk 5.8 to 18 GHz: 125 W pk 500 W,µs per pulse	Type - N(m)	Net: 0.8 kg (1.75 lb) Shipping: 1.5 kg (3.25 lb)
8482B	100 kHz to 4.2 GHz	100 kHz to 2 GHz: 1.10 2 GHz to 4.2 GHz: 1.18	+35 dBm to + 44 dBm: (±4%)	0°C to 350°C: 30W avg ² 35°C to 550°C: 25W avg 0.01 to 5.8 GHz: 500W pk 5.8 to 18 GHz: 125 W pk 500 W - µs per pulse	Type - N(m)	Net: 0.8 kg (1.75 lb) Shipping: 1.5 kg (3.25 lb)

3 Watt sensors, 100 µW to 3 W (–10 dBm to +35 dBm)

Model	Frequency range	Maximum SWR	Power linearity (1)	Maximum power	Connector type	Weight
8481H	10 MHz to 18 GHz	10 MHz to 8 GHz: 1.20 8 GHz to 12.4 GHz: 1.25 12.4 GHz to 18 GHz: 1.30	+25 dBm to + 35 dBm: (±5%)	3.5 W avg, 100 W pk 100 W,µs per pulse	Type - N (m)	Net: 0.2 kg (0.38 lb) Shipping: 0.5 kg (1.0 lb)
8482H	100 kHz to 4.2 GHz	100 kHz to 4.2 GHz: 1.20	+25 dBm to + 35 dBm: (±5%)	3.5 W avg, 100 W pk 100 W,µs per pulse	Type - N (m)	Net: 0.2 kg (0.38 lb) Shipping: 0.5 kg (1.0 lb)

100 mW sensors, 1 µW to 100 mW (–30 dBm to +20 dBm)

Model	Frequency range	Maximum SWR	Power linearity (1)	Maximum power	Connector type	Weight
8485A	50 MHz to 26.5 GHz	50 MHz to 100 MHz: 1.15 100 MHz to 2 GHz: 1.10 2 GHz to 12.4 GHz: 1.15 12.4 GHz to 18 GHz: 1.20 18 GHz to 26.5 GHz: 1.25	+10 dBm to + 20 dBm: (±3%)	300 mW avg, 15 W pk 30 W,µs per pulse	APC - 3.5mm(m)	Net: 0.2 kg (.38 lb) Shipping: 0.5 kg (1.0 lb)
Option 8485A-033	50 MHz to 33 GHz	26.5 GHz to 33 GHz: 1.40	+10 dBm to + 20 dBm: (±3%)	300 mW avg, 15 W pk 30 W,µs per pulse	APC - 3.5mm(m)	Net: 0.2 kg (.38 lb) Shipping: 0.5 kg (1.0 lb)
8481A	10 MHz to 18 GHz	10 MHz to 30 MHz: 1.40 30 MHz to 50 MHz: 1.18 50 MHz to 2 GHz: 1.10 2 GHz to 12.4 GHz: 1.18 12.4 GHz to 18 GHz: 1.28	+10 dBm to + 20 dBm: (±3%)	300 mW avg, 15 W pk 30 W,µs per pulse	Type - N (m)	Net: 0.2 kg (0.38 lb) Shipping: 0.5 kg (1.0 lb)
8482A	100 kHz to 4.2 GHz	100 kHz to 300 kHz: 1.60 300 kHz to 1 MHz: 1.20 1 MHz to 2 GHz: 1.10 2 GHz to 4.2 GHz: 1.30	+10 dBm to + 20 dBm: (±3%) 30 W,µs per pulse	300 mW avg, 15 W pk	Type - N (m)	Net: 0.2 kg (0.38 lb) Shipping: 0.5 kg (1.0 lb)
8483A (75 ohm)	100 kHz to 2 GHz	100 kHz to 600 kHz: 1.80 600 kHz to 2 GHz: 1.18	+10 dBm to + 20 dBm: (±3%)	300 mW avg, 10 W pk	Type - N (m) (75 ohm)	Net: 0.2 kg (0.38 lb) Shipping: 0.5 kg (1.0 lb)
R8486A	26.5 GHz to 40 GHz	26.5 GHz to 40 GHz: 1.40	+10 dBm to + 20 dBm: (±3%)	300 mW avg, 15 W pk 30 W,µs per pulse	Waveguide flange UG-599/U	Net: 0.26 kg (0.53 lb) Shipping: .66 kg (1.3 lb)
Q8486A	33 GHz to 50 GHz	33 GHz to 50 GHz: 1.50	+10 dBm to + 20 dBm: (±3%)	300 mW avg, 15 W pk 30 W,µs per pulse	Waveguide flange UG-383/U	Net: 0.26 kg (0.53 lb) Shipping: .66 kg (1.3 lb)
V8486A	50 GHz to 75 GHz	50 GHz to 75 GHz: 1.06	+10 dBm to + 20 dBm: (±2%) -30 dBm to + 10 dBm: (±1%)	200 mW avg, 40 W pk (10,µs per pulse, 0.5% duty cycle)	Waveguide flange UG-385/U	Net: 0.4 kg (0.9 lb) Shipping: 1 kg (2.1 lb)
W8486A	75 GHz to 110 GHz	75 GHz to 110 GHz: 1.08	(±2%)	200 mW avg, 40 W pk (10,µs per pulse, 0.5% duty cycle)	Waveguide flange UG-387/U	Net: 0.4 kg (0.9 lb) Shipping: 1 kg (2.1 lb)
8487A	50 MHz to 50 GHz	50 MHz to 100 MHz: 1.15 100 MHz to 2 GHz: 1.10 2 GHz to 12.4 GHz: 1.15 12.4 GHz to 18 GHz: 1.20 18 GHz to 26.5 GHz: 1.25 26.5 GHz to 40 GHz: 1.30 40 GHz to 50 GHz: 1.50	+10 dBm to + 20 dBm: (±3%)	300 mW avg, 15 W pk 30 W,µs per pulse	2.4 mm (m)	Net: 0.14 kg (.28 lb) Shipping: 0.5 kg (1.0 lb)

1. Negligible deviation except for those power ranges noted.

2. For pulses greater than 30 W, the maximum average power (P_a) is limited by the energy per pulse (E) in W,µs according to $P_a = 30-0.02 E$.

8480 series sensors (with EPM series power meters)

High sensitivity sensors, 100 pW to 10 μW (–70 dBm to –20 dBm)

Model	Frequency range	Maximum SWR	Power linearity ¹	Maximum power	Connector type	Weight
8481D ³	10 MHz to 18 GHz	10 MHz to 30 MHz: 1.40 30 MHz to 3 GHz: 1.15 4 GHz to 10 GHz: 1.20 10 GHz to 15 GHz: 1.30 15 GHz to 18 GHz: 1.50	-30 dBm to -20 dBm: (±1%)	100 mW avg, 100 m W pk	Type - N (m)	Net: 0.16 kg (0.37 lb) Shipping: 0.9 kg (2.0 lb)
8485D ³	50 MHz to 26.5 GHz	0.05 GHz to 0.1 GHz: 1.19 0.1 GHz to 4 GHz: 1.15 4 GHz to 12 GHz: 1.19 12 GHz to 18 GHz: 1.25 18 GHz to 26.5 GHz: 1.29	-30 dBm to -20 dBm: (±2%)	100 mW avg, 100 m W pk	APC - 3.5mm (m)	Net: 0.2 kg (.38 lb) Shipping: 0.5 kg (1.0 lb)
Option 8485D-033	50 MHz to 33 GHz	26.5 GHz to 33 GHz: 1.35	-30 dBm to -20 dBm: (±2%)	100 mW avg, 100 m W pk	APC - 3.5mm (m)	Net: 0.2 kg (.38 lb) Shipping: 0.5 kg (1.0 lb)
8487D ³	50 kHz to 50 GHz	0.05 GHz to 0.1 GHz: 1.19 0.1 GHz to 4 GHz: 1.15 2 GHz to 12.4 GHz: 1.20 12.4 GHz to 18 GHz: 1.29 18 GHz to 34 GHz: 1.37 34 GHz to 40 GHz: 1.61 40 GHz to 50 GHz: 1.89	-30 dBm to -20 dBm: (±2%)	100 mW avg, 100 m W pk 30 W.μs per pulse	2.4 mm (m)	Net: 0.2 kg (0.38 lb) Shipping: 0.5 kg (1.0 lb)
R8486D ³	26.5 GHz to 40 GHz	26.5 GHz to 40 GHz: 1.40	-30 dBm to -25 dBm: (±3%) -25 dBm to -20 dBm: (±5%)	100 mW avg, or pk 40 V dc max	Waveguide flange UG-599/U	Net: 0.26 kg (0.53 lb) Shipping: .66 kg (1.3 lb)
Q8486D ³	33 GHz to 50 GHz	33 GHz to 50 GHz: 1.40	-30 dBm to 25 dBm: (±3%) -25 dBm to -20 dBm: (±5%)	100 mW avg, or pk 40 V dc max	Waveguide flange UG-383/U	Net: 0.26 kg (0.53 lb) Shipping: 0.66 kg (1.3 lb)

1. Negligible deviation except for those power ranges noted.
2. For pulses greater than 30 W, the maximum average power (P_a) is limited by the energy per pulse (E) in W.μs according to $P_a = 30 \cdot 0.02 E$.
3. Includes 11708A 30 dB attenuator for calibrating against 0 dBm, 50 MHz power reference. The 11708A is factory set to 30 dB ±0.05 dB at 50 MHz, traceable to NIST. SWR < 1.05 at 50 MHz.

With compliments

Helmut Singer Elektronik

www.helmut-singer.de info@helmut-singer.de
fon +49 241 155 315 fax +49 241 152 066
Feldchen 16-24 D-52070 Aachen Germany



Agilent Email Updates

www.agilent.com/find/emailupdates

Get the latest information on the products and applications you select.



Agilent Direct

www.agilent.com/find/agilentdirect

Quickly choose and use your test equipment solutions with confidence.



www.agilent.com/find/open

Agilent Open simplifies the process of connecting and programming test systems to help engineers design, validate and manufacture electronic products. Agilent offers open connectivity for a broad range of system-ready instruments, open industry software, PC-standard I/O and global support, which are combined to more easily integrate test system development.

www.agilent.com

Agilent Technologies' Test and Measurement Support, Services, and Assistance

Agilent Technologies aims to maximize the value you receive, while minimizing your risk and problems. We strive to ensure that you get the test and measurement capabilities you paid for and obtain the support you need. Our extensive support resources and services can help you choose the right Agilent products for your applications and apply them successfully. Every instrument and system we sell has a global warranty. Two concepts underlie Agilent's overall support policy: "Our Promise" and "Your Advantage."

Our Promise

Our Promise means your Agilent test and measurement equipment will meet its advertised performance and functionality. When you are choosing new equipment, we will help you with product information, including realistic performance specifications and practical recommendations from experienced test engineers. When you receive your new Agilent equipment, we can help verify that it works properly and help with initial product operation.

Your Advantage

Your Advantage means that Agilent offers a wide range of additional expert test and measurement services, which you can purchase according to your unique technical and business needs. Solve problems efficiently and gain a competitive edge by contracting with us for calibration, extra-cost upgrades, out-of-warranty repairs, and onsite education and training, as well as design, system integration, project management, and other professional engineering services. Experienced Agilent engineers and technicians worldwide can help you maximize your productivity, optimize the return on investment of your Agilent instruments and systems, and obtain dependable measurement accuracy for the life of those products.

United States:

(tel) 800 829 4444
(fax) 800 829 4433

Canada:

(tel) 877 894 4414
(fax) 800 746 4866

China:

(tel) 800 810 0189
(fax) 800 820 2816

Europe:

(tel) 31 20 547 2111

Japan:

(tel) (81) 426 56 7832
(fax) (81) 426 56 7840

Korea:

(tel) (080) 769 0800
(fax) (080) 769 0900

Latin America:

(tel) (305) 269 7500

Taiwan:

(tel) 0800 047 866
(fax) 0800 286 331

Other Asia Pacific

Countries:

(tel) (65) 6375 8100
(fax) (65) 6755 0042

Email: tm_ap@agilent.com

Contacts revised: 09/26/05

For more information on Agilent Technologies' products, applications or services, please contact your local Agilent office. The complete list is available at:

www.agilent.com/find/contactus

Product specifications and descriptions in this document subject to change without notice.

© Agilent Technologies, Inc. 2002, 2005, 2006

Printed in USA, June 4, 2006

5965-6382E

With compliments

Helmut Singer Elektronik

www.helmut-singer.de info@helmut-singer.de

fon +49 241 155 315 fax +49 241 152 066

Feldchen 16-24 D-52070 Aachen Germany