



# HYDROMATIC®

## 118 SYSTEM

### Sump Pump Hide-Away Basin Package

V-A1/118 Hide-Away System Includes:

- V-A1, 115V Automatic Submersible Sump Pump
- Polyethylene water box with cover, schedule 40 PVC nipple and swing check valve

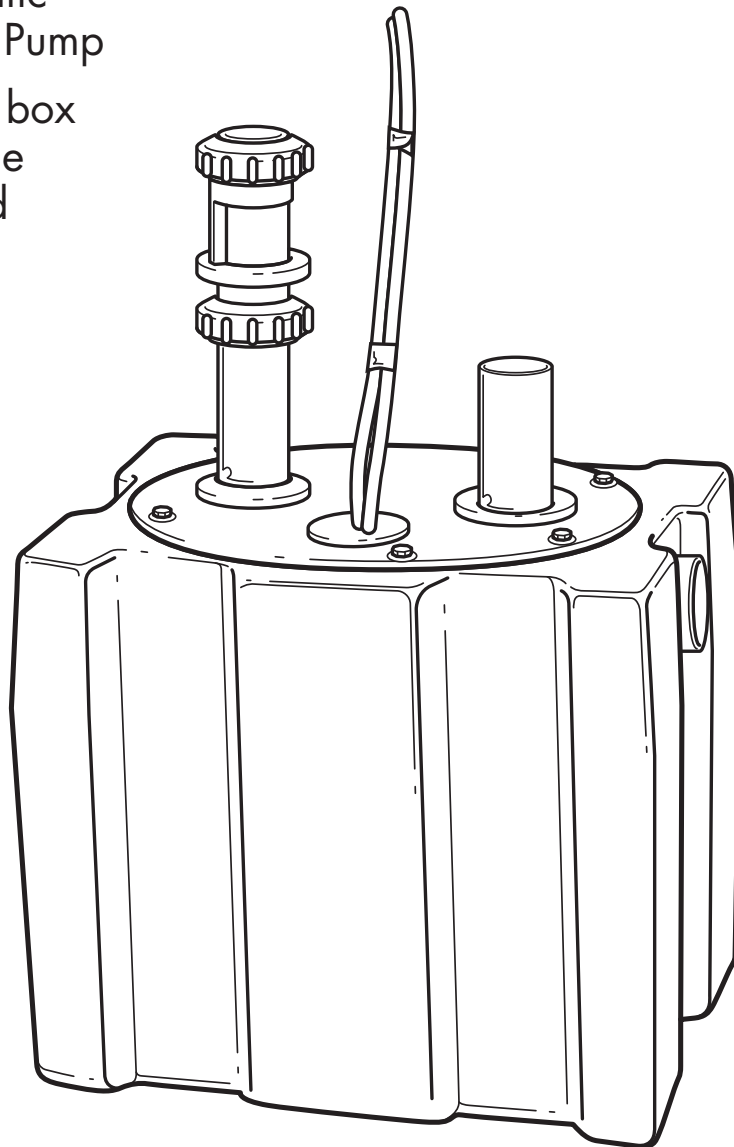

NOTE! To the installer: Please make sure you provide this manual to the owner of the pumping equipment or to the responsible party who maintains the system.



**Pentair**  
**Water™**

## General Information

Thank you for purchasing your Hydromatic® product. To help ensure years of trouble-free operation, please read the following manual carefully.

### Before Operation:

Read the following instructions carefully. Reasonable care and safe methods should be practiced. Check local codes and requirements before installation.

### Attention:

This manual contains important information for the safe use of this product. Read this manual completely before using this product and refer to it often for continued safe product use. **DO NOT THROW AWAY OR LOSE THIS MANUAL.** Keep it in a safe place so that you may refer to it often.

### Warning:

Before handling these pumps and controls, always disconnect the power first. Do not smoke or use sparkable electrical devices or flames in a septic (gaseous) or possible septic sump.

## Pump Warning

Warranty void if product is modified, drilled, painted, or altered in any way; if used to pump hot water, or to pump liquids other than water (such as but not limited to chemicals, fertilizers, flammable liquids, herbicides, mud, tar, cement, wood chips); or otherwise abused.

The model 118 Hide-Away Basin System is specially designed for pumping wastewater from laundry trays, washing machines, wet bars,

water softeners, dehumidifiers, etc. This pump system installs above floor level, no need to dig a sump! This pump system cannot be used for laundry/dishwasher applications in a commercial or industrial environment.

## Installation Instructions

Diagram 1 shows the various connections that must be made for proper installation and operation. This is only a guide; actual installation may vary depending on the particular situation.

### Inlet:

A 1-1/2" inlet is provided on the 118 Hide-Away Basin System. One method of hookup is to use a 1-1/2" PVC MIP adapter or a 1-1/2" PVC MIP marvel connection (or a similar type of connection). You may use a 1-1/2" extension tailpiece or 1-1/2" PVC pipe; it depends on the type of fittings used on the basin inlet. The P-Trap should be installed once the appropriate connections are made on the basin inlet. Once these fittings are installed the rest of the piping may be plumbed.

### Vent:

Provision has been made for a 2" vent to allow maximum volume for any application and proper operation of pump. The vent may be reduced to no less than 1-1/4". Venting is essential for proper pump operation and should not be omitted. The 118 Hide-Away Basin System may be vented into an existing vent stack or use a BOCA in-line vent. Check local codes.

### Discharge:

Do not restrict discharge line below 1-1/4". A check valve **MUST** be installed to prevent backflow of water after each cycle. If you are using 1-1/2" or 1-1/4" PVC pipe on the discharge line, a Hydromatic CV-170 check valve is recommended. Once check valve has been installed, plumb the discharge line into an existing drain line.

### Basin:

Hydromatic's 118 Hide-Away Basin System includes a corrosion-resistant polypropylene tank with a gasket cover.

## System Maintenance

### Caution:

Always disconnect pump from the electrical power source before doing any maintenance. Your sink pump system is manufactured for easy maintenance. Each unit is individually factory-tested to ensure proper adjustment and operation. If unit fails to operate properly, carefully read instructions again to make sure correct procedure has been followed.

## Electrical Information

**WARNING!** Risk of electrical shock. This pump is supplied with a grounding conductor and grounding type attachment plug. To reduce risk of electrical shock, connect only to a properly grounded grounding-type receptacle. This pump has not been investigated for use in swimming pool areas.

**DO NOT WORK ON PUMP UNTIL POWER IS UNPLUGGED.**

DO NOT cut off ground pin or use an adapter fitting. DO NOT use an extension cord. The pump power cord should be connected to a separately fused, grounded 115 volt line with a minimum capacity of 15 amps. NEVER touch the pump when it is connected to electrical power.

The receptacle should be located at least 4 feet above floor level. When wiring this pump follow all local electrical and safety codes and ordinances as well as the most recent National Electrical Code. N.E.C., ANSI/NFPA 70 - 2001.

# 118 Parts List

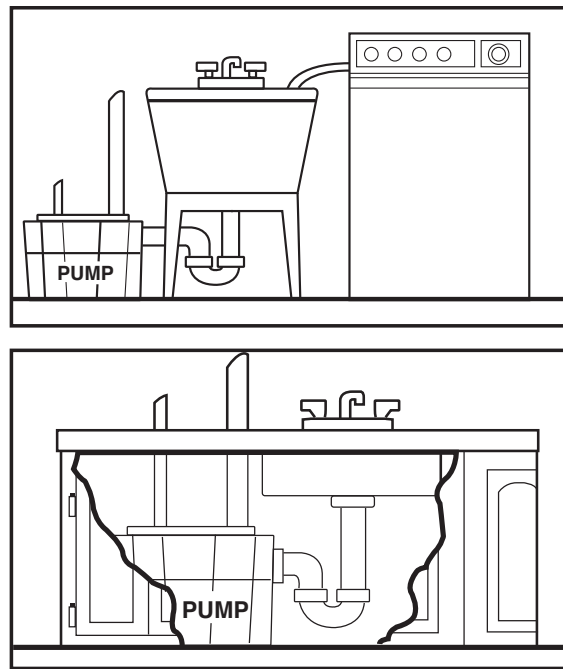
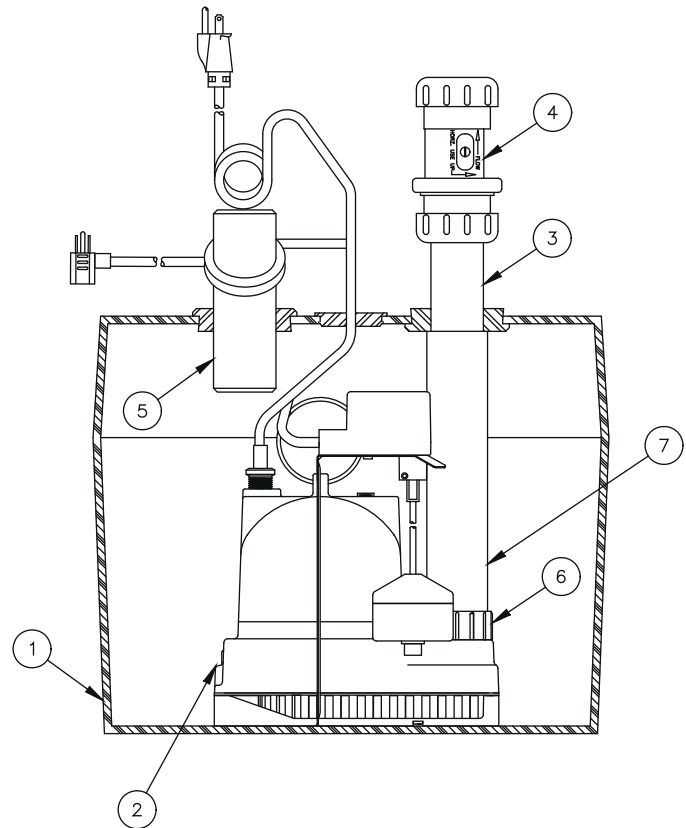
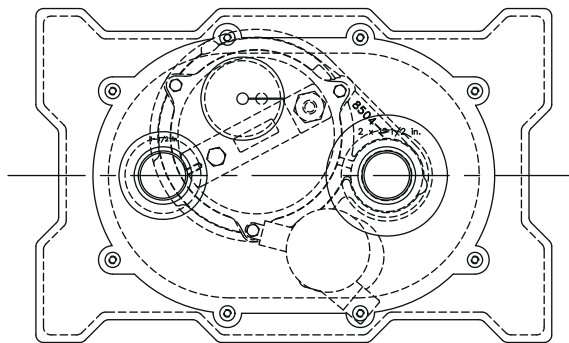

Diagram 1



Ref. No.	Description	Part No.	Qty.
1	POLY BASIN SUMP BOX	113972-004-1	1
2	V-A1 DUMP PUMP W/10' CORD	252249-000-7	1
3	PIPE 1-1/2" PVC SCHEDULE 40, 15-1/4" LG.	312138-006-3	1
4	PVC CHECK VALVE	413254-001-1	1
5	PIPE 1-1/2" PVC SCHEDULE 40, 6" LG.	512138-003-3	1
6	MALE ADAPTER	614070-000-1	1
7	PIPE 2" PVC SCHEDULE 40, 8-1/2" LG.	712173-006-3	1
	LITERATURE MAN. V SERIES	85625-361-1	1
	LITERATURE - INSTALLATION & SERVICE	95625-440-1	1

## WARRANTY

Hydromatic® warrants to the original purchaser of each Hydromatic product(s) that any part thereof that proves to be defective in material or workmanship within one year from date of installation or 18 months from manufacture date, whichever comes first, will be replaced at no charge with a new or remanufactured part, F.O.B. factory. Purchaser shall assume all responsibility and expense from removal, reinstallation and freight. Any item(s) designated as manufactured by others shall be covered only by the express warranty of the manufacturer thereof. This warranty does not apply to damage resulting from accident, alteration, design, misuse or abuse. The pump must be installed, operated and maintained in accordance with the published instructions of the appropriate Installation & Service Manual.

All dual seal non-clogs and 3–5 HP grinders must have seal failure and heat sensors attached and functional for Warranty to be in effect. If a seal failure should occur, Hydromatic will cover only the lower seal and labor thereof. Labor is based on Authorized Service Center contract allowance. If the heat sensor is not attached and functional, Warranty is void. If the seal failure sensor is not attached and functional, Warranty is void.

If the material furnished to the Buyer shall fail to conform to this contract or to any of the terms of this written warranty, Hydromatic shall replace such nonconforming material at the original point of delivery and shall furnish instruction for its disposition. Any transportation charges involved in such disposition shall be for the Buyer's account. The Buyer's exclusive and sole remedy on account or in respect of the furnishing of material that does not conform to this contract or to this written warranty, shall be to secure replacement thereof as aforesaid. Hydromatic shall not in any event be liable for the cost of any labor expended on any such material or for any incidental or consequential damages to anyone by reason of the fact that such material does not conform to this contract or to this written warranty.

ALL IMPLIED WARRANTIES, INCLUDING THE IMPLIED WARRANTY OF MERCHANTABILITY AND THE IMPLIED WARRANTY OF FITNESS FOR A PARTICULAR PURPOSE, ARE DISCLAIMED TO THE SAME EXTENT AS THE EXPRESS WARRANTY CONTAINED HEREIN. Some states do not allow limitations on how long an implied warranty lasts, so the above limitation may not apply to you.

MANUFACTURER EXPRESSLY DISCLAIMS AND EXCLUDES ANY LIABILITY FOR CONSEQUENTIAL OR INCIDENTAL DAMAGES FOR BREACH OF ANY EXPRESS OR IMPLIED WARRANTY ARISING IN CONNECTION WITH THIS PRODUCT, INCLUDING WITHOUT LIMITATION, WHETHER IN TORT, NEGLIGENCE, STRICT LIABILITY CONTRACT OR OTHERWISE. Some states do not allow the exclusion or limitation of incidental or consequential damages, so the above limitation or exclusion may not apply to you. This warranty gives you specific legal rights, and you may also have other rights which vary from state to state.

– Your Authorized Local Distributor –



**HYDROMATIC®**

Pentair Water

**USA**

740 East 9th Street, Ashland, Ohio 44805  
Tel: 419-289-3042 Fax: 419-281-4087

[www.hydromatic.com](http://www.hydromatic.com)

**CANADA**

269 Trillium Drive, Kitchener, Ontario, Canada N2G 4W5  
Tel: 519-896-2163 Fax: 519-896-6337