



# INSTRUCTIONS

-J04539

REV. 2008-09-19

## BANK ANGLE SENSOR SWITCH KIT

### GENERAL

#### Kit Number

88115-09

#### Models

This kit must be installed on **2009 and later** FL Touring Models being fitted with a TLE or TLE-Ultra Sidecar Kit.

This kit can also be used as a replacement on those same models already equipped with a TLE or TLE-Ultra Sidecar Kit.

Early 2009 models may not have the correct battery box for the sidecar installation. The battery box must have the inscription "Sidecar Tip Sensor" molded into the right front side of the battery box.

#### Additional Parts Required

Early 2009 FL Touring models will require the Battery Tray Kit (66281-09A) to use the Bank Angle Sensor when installing the TLE or TLE-Ultra Sidecar Kit.

Following installation of the Bank Angle Sensor Switch, the DIGITAL TECHNICIAN® II and Data Link must be used to program the security module (TSM/TSSM/HFSM) for sidecar (with gravity activated bank angle sensor) application.

### ⚠ WARNING

**Failure to properly configure the TSM/TSSM/HFSM can cause engine to shutdown which could lead to loss of control and death or serious injury. (00581b)**

If the security module is not configured and calibrated after the sidecar and bank angle sensor has been installed, the motorcycle will operate in solo mode, and the engine may shut down when the vehicle takes a sharp corner. Additionally, the turn signals may cancel prematurely when navigating rough conditions (i.e. potholes, bumps, etc.).

#### Kit Contents

See Figure 2 and Table 1.

### INSTALLATION

#### NOTE

*If equipped with the optional "Harley-Davidson Smart Security System", verify that the security status lamp in the speedometer face is **not** flashing (security system disarmed) before proceeding.*

### ⚠ WARNING

**To prevent accidental vehicle start-up, which could cause death or serious injury, remove main fuse before proceeding. (00251b)**

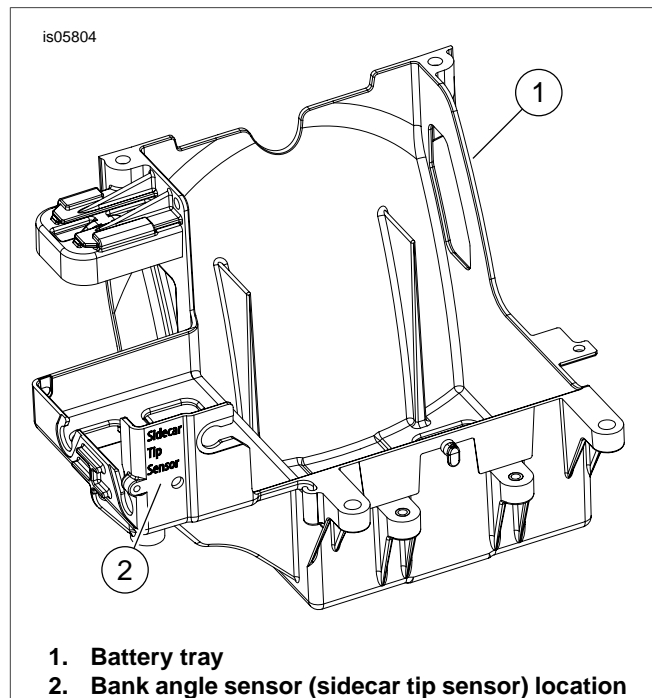

Figure 1. Battery Tray for Bank Angle Sensor

1. See Figure 1. Remove the right-side cover. If the battery tray (1) **does not** have the inscription "Sidecar Tip Sensor" as shown in Figure 1 you must purchase and install the Battery Tray Kit (66281-09A) before installing the sidecar.
2. Remove the left-side saddlebag according to the instructions in the Service Manual. Remove the left-side cover and disconnect the main fuse.
3. Where you removed the right-side cover, disconnect the gray twelve-way socket housing from the security module. Plug it into the twelve-way pin housing on the bank angle sensor harness from the kit.
4. Plug the gray twelve-way socket housing from the bank angle sensor harness into the security module.
5. Plug the three-way socket housing from the bank angle sensor harness into the bank angle sensor switch.
6. Install the bank angle sensor switch to the right front corner of the battery tray with the screw from the kit.
7. Refer to the Service Manual and follow the instructions given to install the right-side cover, tucking any excess wires under the cover. Install the main fuse, left-side cover and saddlebag per the instructions in the Service Manual.

**NOTES**

If the Bank Angle Switch is actuated by tilting, the ignition circuit is disabled. The Bank Angle Switch may be reset by turning the ignition switch OFF for five seconds, then ON.

**Whenever the sidecar is removed, the Bank Angle Switch kit should be removed and the security module should be**

switched back to solo vehicle operation by a Harley-Davidson dealer.

Instructions for installing or removing the Bank Angle Switch Kit, and procedures for configuring the security module are given in the Sidecar Service Manual, Part Number 99485-xx.

**SERVICE PARTS**

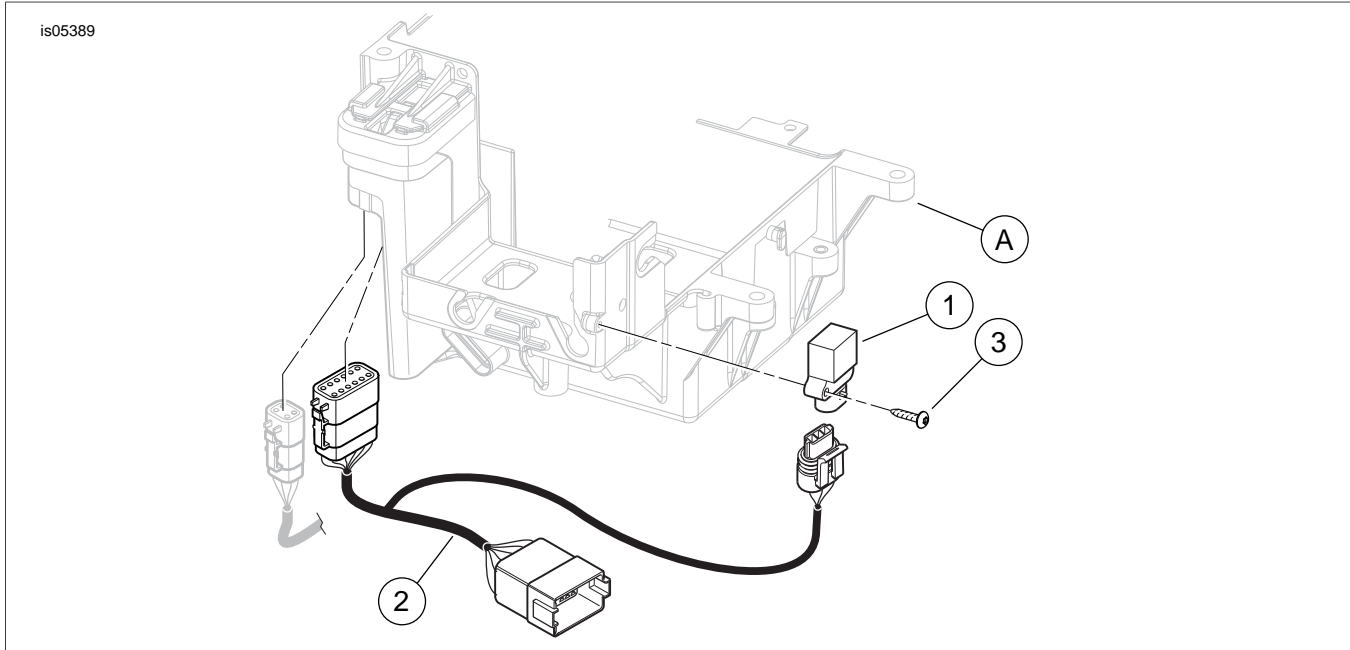

**Figure 2. Service Parts, Bank Angle Sensor Switch Kit**

**Table 1. Service Parts Table**

Item	Description (Quantity)	Part Number
1	Switch, bank angle sensor	32495-98
2	Harness, bank angle sensor	88104-09
3	Screw, self-tapping	4790
<b>Items mentioned in text, but not included in kit:</b>		
A	Battery tray	