



INSTRUCTIONS

-J02622

REV. 2005-05-12

CHROME TOUR-PAK LID TRIM KIT

GENERAL

Kit Number

53936-03

Models

This kit fits 1993-2005 Touring models equipped with a King or Chopped Tour-Pak (except 100th Anniversary Two-tone versions.) This kit does not fit with Mini Tour-Pak Lid Rack (part number 53100-96) or previously installed Tour-Pak Lid Organizer (part number 53249-01A).

NOTE

A Service Manual for your model motorcycle is available from a Harley-Davidson Dealer.

Kit Contents

See Figure 4 and Table 1.

INSTALLATION

1. Obtain template from this kit and carefully cut around the outer line. Measure the 1 inch reference line to be sure of correct scale.
2. See Figure 1. Carefully place template in recessed area of Tour-Pak and align the template with the 3 surrounding ridges (forming the recess). Center template by measuring equal distances from side of template to left and right ridges and at top corners. Tape the template to the Tour-Pak in the centered location.
3. Use a scribe or similar tool to carefully mark the exact center of each of the five trim mounting holes on the template. Press hard enough that marking will penetrate paper and will also mark the Tour-Pak surface.
4. Place a piece of masking tape at each of the marked holes and copy the scribe marks made in the last step to the masking tape.

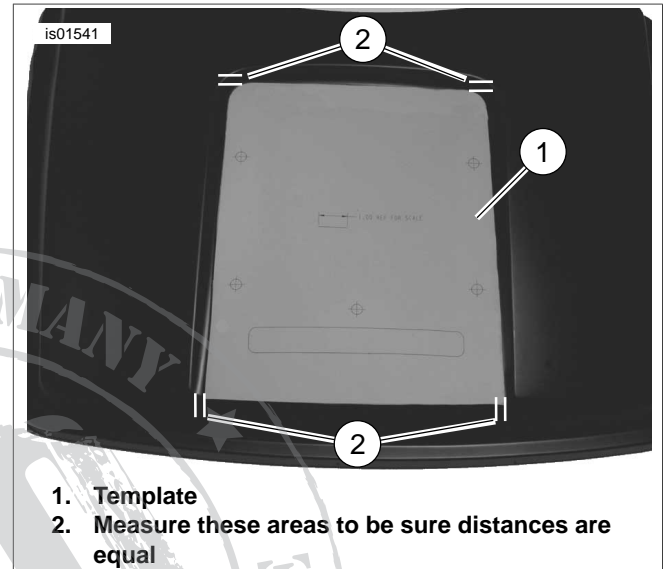

Figure 1. Center of Template

NOTE

Apply masking tape to the Tour-Pak cover at the five points where you will be drilling the trim mounting holes. The tape will serve as a marker for drilling as well as to keep the fiberglass surface from chipping or splintering during the drilling process.

NOTE

Remove all belongings from within the Tour-Pak to avoid possible contact with the moving drill bit during the following drilling procedures.

5. Drill starter holes using a 1/16 inch drill bit. Using a 3/8 (.375) inch drill bit, drill the finished holes. Remove the masking tape pieces.
6. See Figure 4. Obtain the Tour-Pak lid trim piece (4) and five of the rubber washers (3) from kit. At each of the mounting studs on the trim piece, carefully fit a rubber washer onto the stud end.

NOTE

The rubber washers are sized specifically to surround the stud with a seal-tight fit. Make sure washers are placed correctly at each of the mounting studs.

7. Open and lift up the lid of the Tour-Pak. Place the chrome lid trim piece onto the lid carefully aligning each of the mounting studs (with washers) with each of the drilled holes.

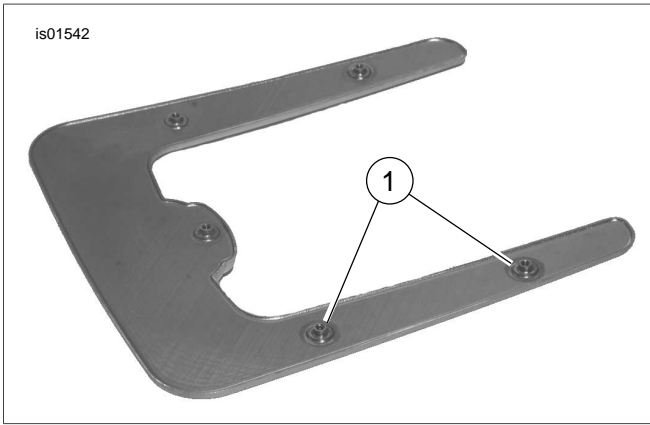

Figure 2. Trim Piece Mounting Studs

8. See Figure 3. Obtain a rubber washer (3), #10 metal washer (2) and self-tapping mounting screw (1) from kit. Install the metal washer followed by the rubber washer onto the self-tapping screw.
9. While holding the lid trim with one hand, hold screwdriver as straight and as parallel to the mounting stud as possible and tighten the self-tapping screw until the lid trim piece begins to draw up tight, then stop. Repeat Steps 8 and 9 for the remaining screws and washers.
10. Return to all five screws and tighten evenly and securely, but do NOT overtighten.

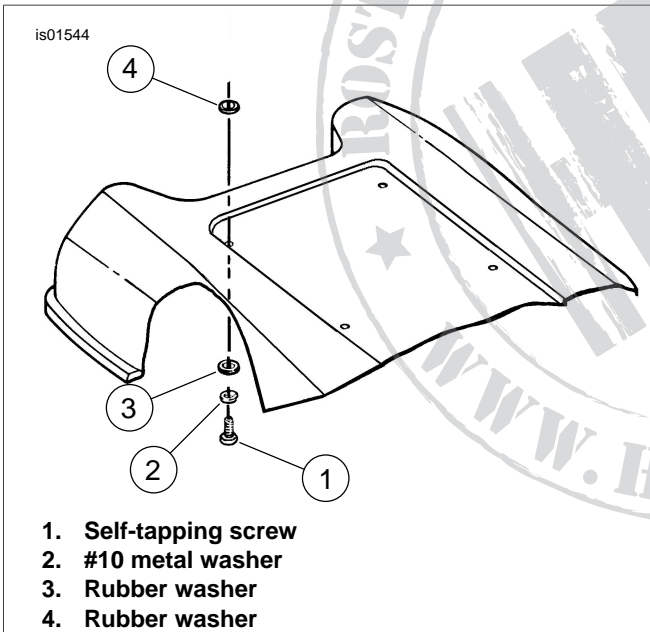

Figure 3. Lid Trim Kit Drill and Hardware Locations

SERVICE PARTS

See Figure 4 and Table 1.

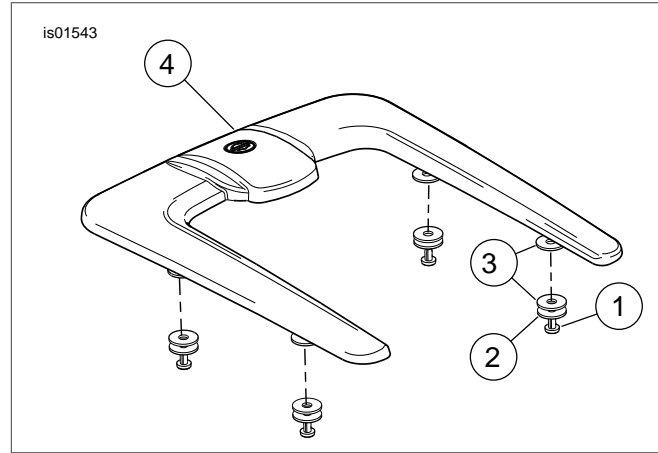

Figure 4. Service Parts: Chrome Tour-Pak Lid Trim Kit

Table 1. Service Parts

Item	Description (Quantity)	Part Number
1	Screw, panhead, Torx #10-24 (5)	4194
2	Washer, #10 (wide) (5)	6831
3	Washer, EPDM (10)	57964-97
4	Lid, Tour-Pak, chrome trim	Not Sold Separately
5	Template (not shown)	53937-03