

TOSHIBA

FILE NO. A10-9507

SERVICE MANUAL

AIR-CONDITIONER SPLIT WALL TYPE

RAV-M241A-E (Combination with RAS-13EK)

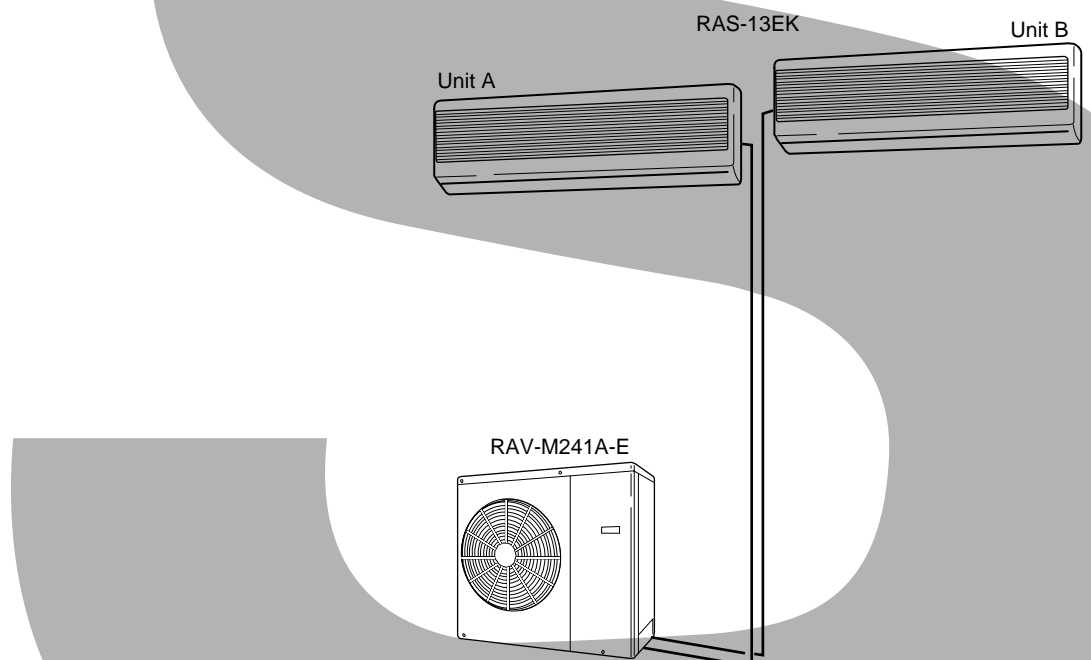

PRINTED IN JAPAN Jan, 1996 ©

|

CONTENTS

1. SPECIFICATIONS	3
2. CONSTRUCTION VIEWS	5
2-1. Outdoor Unit	5
3. WIRING DIAGRAM	6
4. SPECIFICATIONS OF ELECTRICAL PARTS	7
5. REFRIGERANT PIPING DIAGRAM	8
5-1. Refrigerant Piping	9
6. UNIT INSTALLATION	10
6-1. Service Space	10
7. TROUBLESHOOTING CHART FOR RAS-13EK/RAV-M241A-E	11
7-1. What to be Prechecked First	11
7-2. Primary Judgement of Trouble Sources	12
7-3. Troubleshooting Flowcharts	16
7-4. Test Points on the PC Board and List of Voltage Values	19
7-5. How to Check the Remote Control (Including the Indoor PC Board)	20
7-6. PC Board Layout	23
8. EXPLODED VIEWS AND PARTS LIST	24

1. SPECIFICATIONS

Item		Model	RAV-M241A-E
			2 indoor unit
Operation	Unit		A
	*1	BTU/h	12000
Cooling capacity		kcal/h	6000
	*1	BTU/h	24000
		kW	7.0
Power source		Phase	1
		V	220-240
		Hz	50
Power consumption	Cooling	kW	2.4
Power factor	Cooling	%	97
Running current	Cooling	A	10.8
Starting current	Cooling	A	68
Operating noise (SPL*)		dB (A)	53
Refrigerant	Name of refrigerant		R-22
		Charge volume	kg
Refrigerant control			Capillary tube
Interconnection pipe		Gas side size	mm (in.)
		Coupler style	Flare
		Liquid side size	mm (in.)
		Coupler style	Flare
		Standard length	m (ft)
		Maximum length (of one way)	*2 m (ft)
		Minimum length	m (ft)
Maximum height		Indoor unit higher	m (ft)
		Outdoor unit higher	m (ft)
INDOOR UNIT Model			RAS-13EK, SERVICE DATA FILE NO. A00-9502
OUTDOOR UNIT Model			RAV-M241A-E
Dimensions		Height	mm (ft-in.)
		Width	mm (ft-in.)
		Depth	mm (ft-in.)
Net weight			kg (lbs)
Condenser type			Finned tube
Condenser fan type			Propeller fan
Fan motor output		W	63
Compressor		Model	PH160X2-4L
		Output	W
Protective device			Fuse Inner overload relay

*SPL: Sound Pressure Level

Specifications are subject to change without notice.

Note 1:

- Cooling capacity is based on the following temperature conditions.

Evaporator air inlet temperature	27°C DB (80°F DB)
	19.5°C WB (67°F WB)
Condenser air inlet temperature	35°C DB (95°F DB)

Note 2:

- These mean equivalent length.

Note 3:

- Operating range of the units

	Evaporator air inlet temperature	Condenser air inlet temperature
Maximum	32°C DB, 22.5°C WB (95°F DB, 73°F WB)	43°C DB (109°F DB)
Minimum	21°C DB, 15.5°C WB (70°F DB, 60°F WB)	21°C DB (70°F DB)

Remark:

- Be sure to refer to the service manual file No. A00-9502 for the indoor unit RAS-13EK to be connected.

2. CONSTRUCTION VIEWS

2-1. Outdoor Unit

RAV-M241A-E

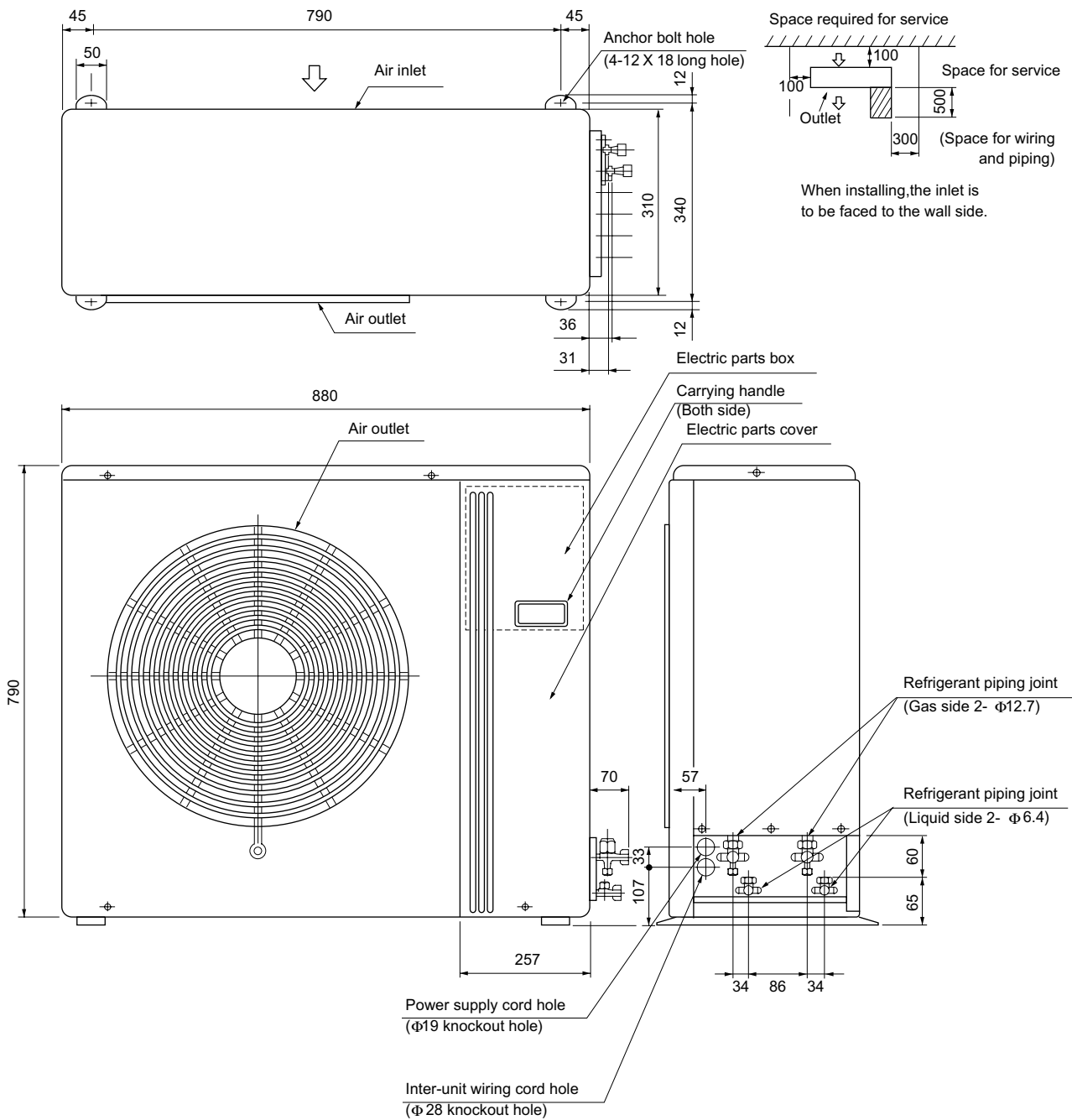

Fig. 2-1

3. WIRING DIAGRAM

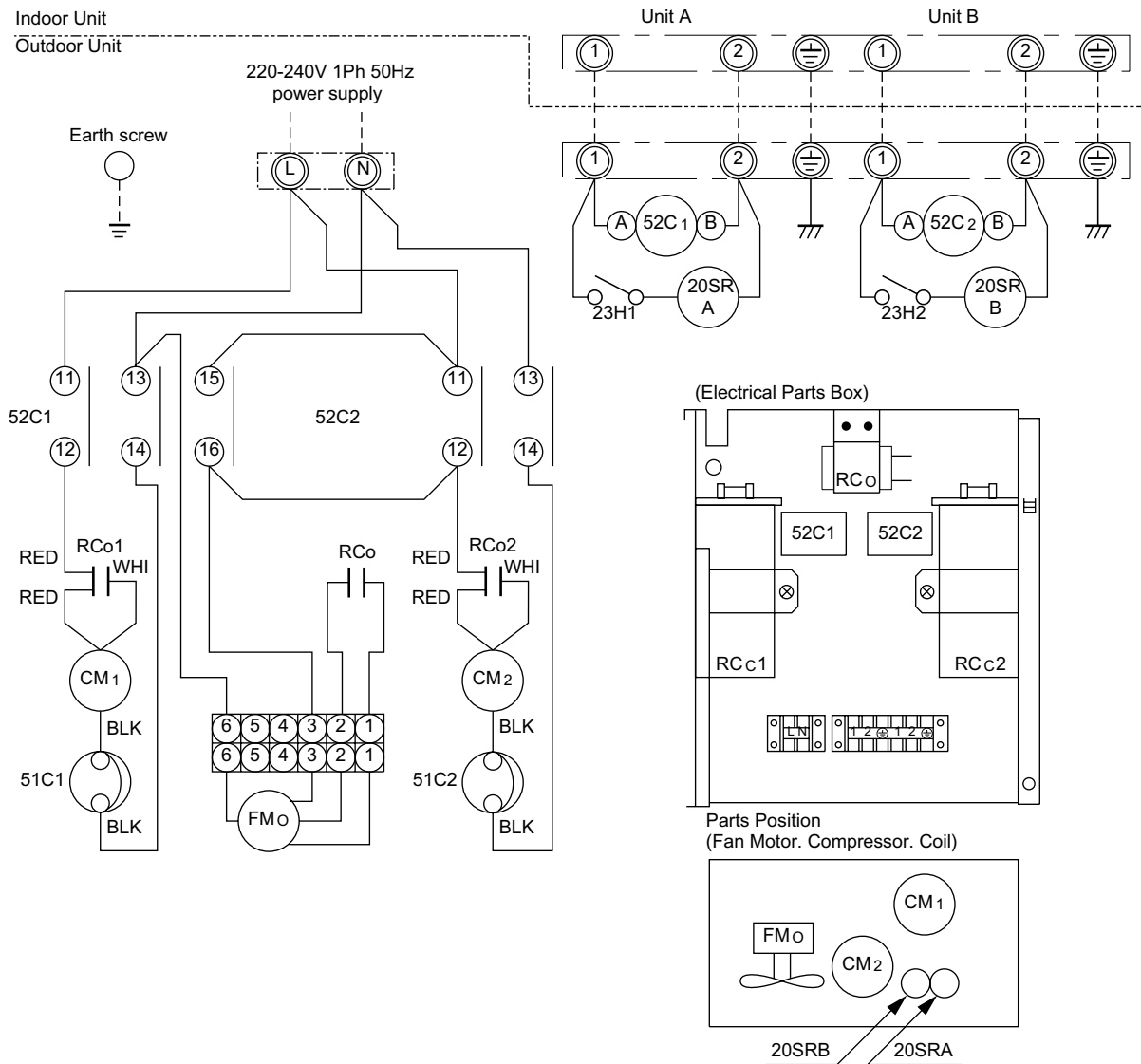

Fig. 3-1

Symbol	Name	Symbol	Name
CM1, 2	Compressor	51C1, 2	Overload relay
FMO	Fan motor	52C1, 2	Magnetic contactor
RCc1, 2	Running capacitor (Compressor)	20SRA, B	Solenoid coil
RCo	Running capacitor (Fan motor)	23H1, 2	Thermostat

⊙ Shows terminal block and figures show terminal numbers.

Broken lines show wiring at site.

Don't operate the units with the magnetic contactor pushed.

4. SPECIFICATIONS OF ELECTRICAL PARTS

Parts name	Type	Specifications
Compressor 1, 2	PH160X2-4L	Output 1.1 kW, 2 pole, 1 ϕ , 220-240V, 50 Hz Winding resistance: Main coil 2.2 Ω , Aux. coil 3.8 Ω
Fan motor	STF-200-63B	Output 63W, 6 pole, 1 ϕ , 220-240V, 50 Hz
Magnetic contactor	VC20FA	AC 240V
Capacitor	MT-40MP356W	For compressor 1, 2, AC 400V, 35 μ F
	EAG45M355UF1	For fan motor, AC 450V, 3.5 μ F
Solenoid coil (2-way valve)	NEV AC240	AC 220-240V
Bimetal thermostat	CS-12	110°C ON, 95°C OFF

5. REFRIGERANT PIPING DIAGRAM

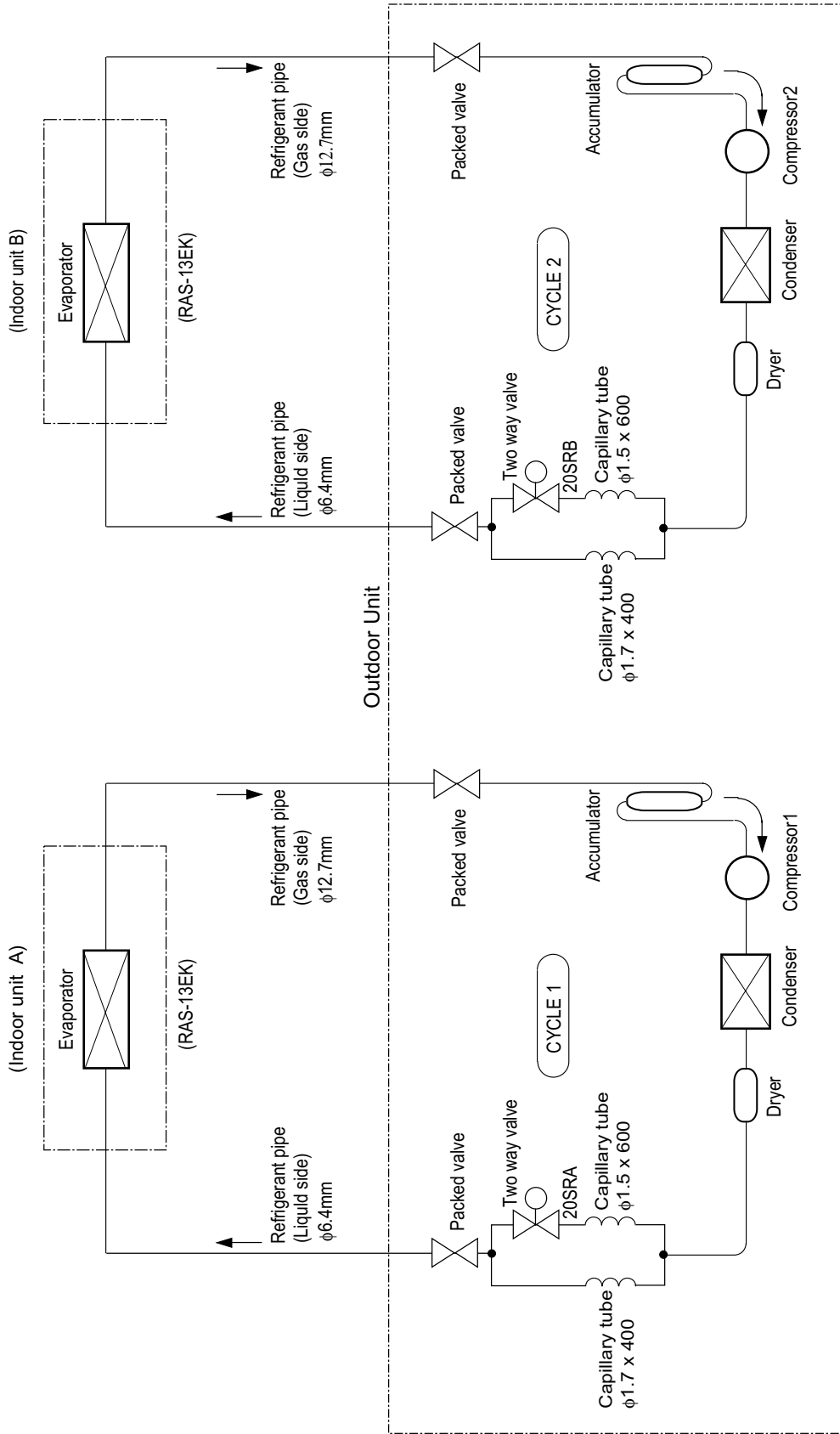

Fig. 5-1

5-1. Refrigerant Piping

5-1-1. Permissible Piping Length and Head

The minimum inter-unit refrigerant piping length shall be 2m.

Limit the number of bends in the refrigerant piping to 10 or less.

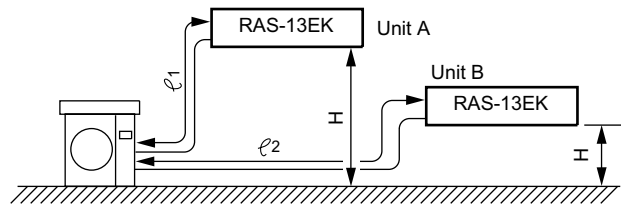

Fig. 5-2

Table 5-1

Model	Connectable indoor unit number	Permissible piping length (l_1 , l_2)	Permissible piping head (H)	Remarks
RAS-13EK	2	15m	5m	Fig. 5-2

5-1-2. Piping Material and Sizes

Table 5-2

Piping material		Phosphate deoxidized copper seamless pipes for air conditioners
Model		RAS-13EK
Piping size (mm)	Larger	12.7
	Smaller	6.4

5-1-3. Air Purging

- Subject the refrigerant tube of outdoor and indoor units to air purge with a vacuum pump.
- Do not carry out this air purge by using the refrigerant filled in the outdoor unit.
- To handle valves, a 5 mm hexagon wrench is needed.

5-1-4. Refrigerant Pipe Connecting Position

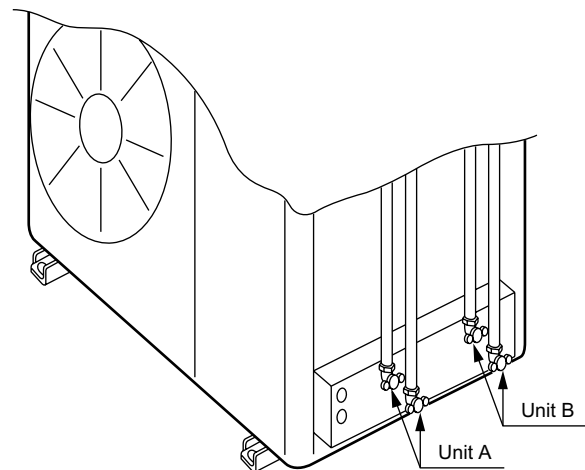

Fig. 5-3

5-1-5. Additional Refrigerant Quantities

Table 5-2

Model	RAV-M241A-E
Addition per meter	No need

6. UNIT INSTALLATION

6-1. Service Space

Ensure that there is sufficient space around the outdoor unit for installation and servicing.

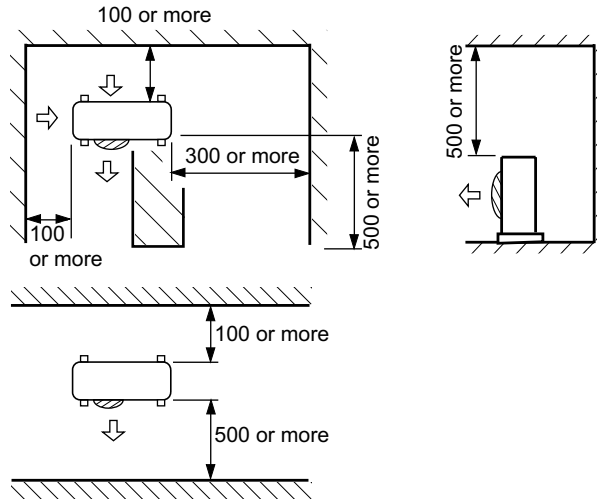

Fig. 6-1

- Do not install in a place that can increase the vibration and amplify the noise level of the units.
- Be sure to fix the outdoor unit with four (4) M10 anchor bolts according to foundation drawings below.

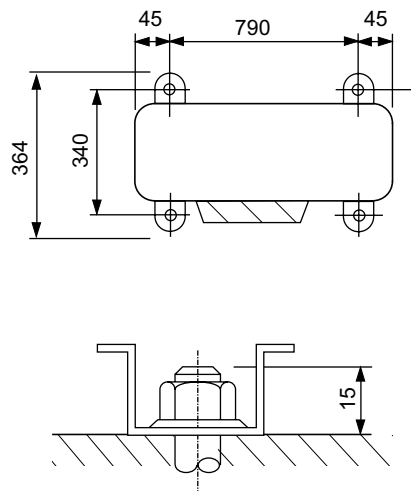

Fig. 6-2

7. TROUBLESHOOTING CHART FOR RAS-13EK/RAV-M241A-E

Troubleshooting Procedures:

- Following details of “What to be prechecked first”, make sure of the basic items.
- When there is no trouble corresponding to above, check in detail the faulty parts following “How to judge faulty parts by symptoms” later.

7-1. What to be Prechecked First

7-1-1. Power Supply Voltage

The power supply voltage must be from AC 198V to 264V. If the power voltage is not within this range, the air-conditioner may not work normally.

7-1-2. Incorrect Cable Connection between Indoor and Outdoor Units.

The indoor unit is connected to the outdoor unit with 3 cables. Make certain that the terminals of indoor and outdoor connectors have been connected properly by the same numbers. If not connected as specified, the outdoor unit won't operate normally.

7-1-3. Operations not Regarded as Failure (program operation)

In terms of the control of air-conditioner, the operations shown in Table 7-1 are made as a program operation incorporated in a microcomputer. If a claim is made about the operation, check it corresponds to the contents in the table. If it does, it is an indispensable operation for the control and maintenance of the air-conditioner but not a failure of the units.

- **Operations which are not Deemed Trouble**

Table 7-1

Operation of air-conditioner	Description
When the POWER plug of the indoor unit is inserted, the OPERATION lamp flashes.	The OPERATION lamp flashes, indicating that power is turned on. If this happens, press the START/STOP button once, and flash will stop. Power failure also causes the same lamp to flash.
Room temperature is in the range under which the compressor is turned on, but the compressor will not start.	The compressor will not start while the compressor restart prevention timer (three-minute timer) is actuated. This applies also when power is turned on.
Fan speed remains unchanged when the fan speed button is operated in the dry operation.	Fan speed is fixed at Low in the dry operation.
Room temperature is in the range under which the compressor is turned off, but the compressor will not stop.	The compressor will not stop while the compressor on-hold timer (two-minute timer) is actuated.
The compressor will not switch on or off even when the thermostat control is operated in the dry operation.	In the dry operation, the compressor goes on and off at regular intervals, independent of the thermostat control.

7-2. Primary Judgement of Trouble Sources

7-2-1. Role of Indoor Unit Controller

The indoor unit controller receives the operation commands from the remote control and assumes the following functions.

- Measurement of the draft air temperature of the indoor heat exchanger by using the temperature sensor (T_A)
- Louver motor control
- Control of the indoor fan motor operation
- Control of the LED display
- Control of the outdoor unit compressor and the outdoor fan motor.

7-2-2. Display of Abnormalities and Judgement of the Abnormal Spots

The indoor unit of this machine observes the operation condition of the air conditioner and displays the contents of the self-diagnosis as block displays on the display panel of the indoor unit.

Table 7-2

Block display	Check code	Self-diagnosis	Check code
OPERATION display flashing (1 Hz)	–	Power failure (When power is on)	–
OPERATION display flashing (5 Hz)	00	Temperature sensor (T _A) short/break	0C
OPERATION display flashing (5 Hz)	00	Heat exchanger sensor (T _C) short/break	0d
OPERATION display flashing (5 Hz)	00	Indoor fan lock, abnormality of indoor fan, IC03, D15 short/break	11
OPERATION display flashing (5 Hz)	00	Indoor PC board failure	12
OPERATION and TIMER display flashing (5 Hz)	01	• Thermal fuse is blown (Indoor fan motor is overheat)	04
OPERATION, TIMER and FAN ONLY display flashing (5 Hz)	03	• Gas shortage, other refrigerant cycle trouble • Heat exchanger sensor open/short/break • Overload relay trouble	09
OPERATION, TIMER and FAN ONLY display flashing (5 Hz)	03	Compressor trouble	1d

(1) Judgement from defective operation or abnormal operation

Table 7-3

System	Check		Primary judgement
No reaction on remote control operation	Turn off the power once, turn it on again and try to operate the remote control again.	Remote control is not possible.	The indoor part (including the remote control) is defective.
		Remote control is possible.	O.K.
The outdoor fan does not rotate	The compressor operates.		The outdoor part is defective (outdoor fan motor)
	The compressor does not operate.		The inside part is defective.

(2) Self-diagnosis with remote controller

With the indoor unit controller, self-diagnosis of protective circuit action can be done by turning the remote controller operation into service mode, operating the remote controller, observing the remote controller indicators and checking whether OPERATION lamp flashes (5 Hz).

Note:

- To perform this self-diagnosis, the remote controller with the service code of 43069666 is required.

<How to select remote controller operation mode>

1) Selecting service mode

Push the switch button provided on rear bottom of the wireless remote controller with a tip of pencil for more than 3 seconds. Make sure the setting temperature “**□□**” is displayed on the display and other display is turned off.

2) Selecting ordinary mode

Push the all clear button (ACL) on the rear bottom of the wireless remote controller by a tip of pencil for more than 3 seconds. Make sure the operation mode display, wind volume display, clock display and setting temperature display are turned on and “ : ” of the clock display is blinking.

<Cautions when doing service>

- 1) After completion of servicing, always push the all clear (ACL) button to return the operation mode to the normal mode.
- 2) After completion of servicing by the check code, turn off the power once and then turn on the power to reset memorized contents of the microcomputer to the initial status.

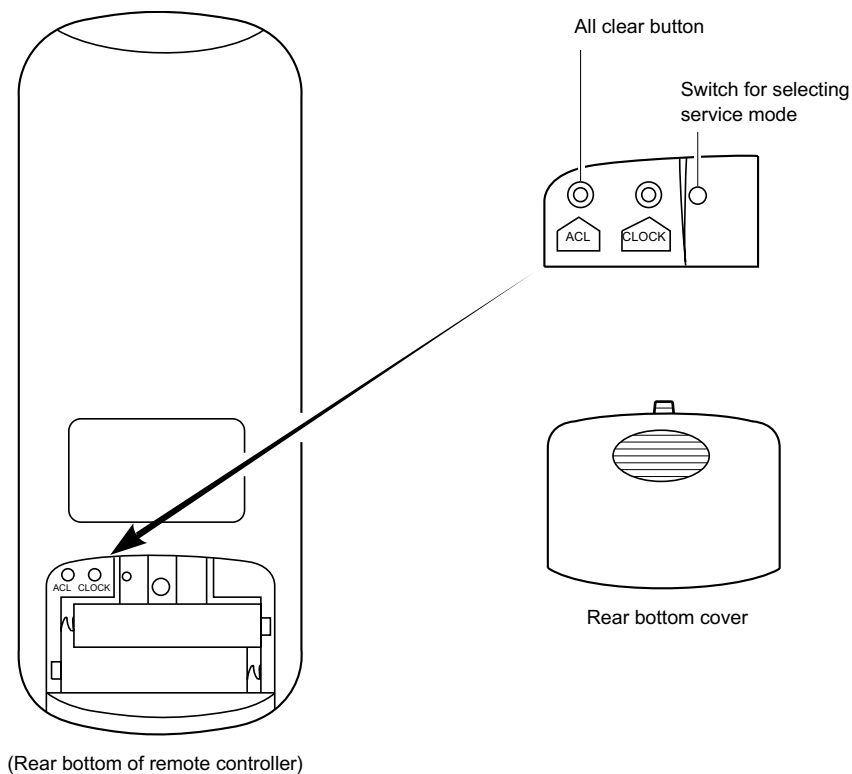



Fig. 7-1

<Self-diagnosis by check codes>

1) The self-diagnosis by the check codes is conducted under the block displays of item B-E.

2) Remote control key operation under the service mode is conducted by ON/OFF or TEMP. The remote control display by each key operation is varied as shown below. Two digit number is displayed in a hexadecimal number.

Table 7-4

Operating key	Indication after operation
ON/OFF	“00”
TEMP.  (Up)	1 is added to data before operation. (Example) “02” → “03”
TEMP.  (Down)	1 is subtracted from data before operation. (Example) “02” → “01”
“AUTO” LOUVER	10 is subtracted from data before operation. (Example) “02” → “12”
“SET” LOUVER	Data before operation is directly transferred. (Example) “02” → “02”

3) The self-diagnosis by the check codes is conducted with procedures shown below.

- a) Enter the service mode and make sure the off timer display of the remote control shows “00”.
- b) Operate the “ON/OFF” key and make sure the timer lamp on the display section is blinking (5 Hz).
- c) At the same time, also make sure the OPERATION lamp is also blinking. This shows that the protection circuit on the indoor PC board is working.



- d) Operate the TEMP.  key and make sure the remote control display shows “01” and blinking of the OPERATION lamp. If the operation lamp is blinking, it shows the protection circuits for connecting cable is working or thermal fuse is blown.
- e) In the same way, operate the TEMP.  key so that the display is increased one by one to continue checks by the self-diagnosis as shown is the next table. From “00” up to “03” check operations of protection circuits for each block, and “04” to “0F” check operations of the typical protection circuits.

Table 7-5

Block level		Diagnosis function				Judgement and action
Check code	Block	Check code	Symptom	Air conditioner status	Condition	
00	Indoor PC board	00	Thermo sensor short/break.	Continued operation	Indicated when detected abnormal.	<ul style="list-style-type: none"> • Check thermo sensor. • If it is OK, check PC board. (Around sensor circuit)
		02	Heat exchanger sensor short/break.	Continued operation	Indicated when detected abnormal.	<ul style="list-style-type: none"> • Check heat exchanger sensor. • If it is OK, check PC board. (Around sensor circuit)
		11	Indoor fan lock, abnormality of indoor fan.	All off.	Indicated when detected abnormal.	<ul style="list-style-type: none"> • Check motor. • Replace PC board, if the same failure occurs, after the motor check.
		12	Abnormality of other indoor unit PC board.	Continued operation	Indicated when detected abnormal.	Replace PC board.
01	Cable connection/ Thermal fuse	04	Wrong wiring or disconnection of connective cable.	All off.	Indicated when detected abnormal.	<ul style="list-style-type: none"> • Check flat cable correct if wiring is wrong. • If it is OK, check PC board.
			<ul style="list-style-type: none"> • Thermal fuse cut off. • Indoor fan lock, abnormality of indoor fan. 	All off.	Indicated when detected abnormal.	<ul style="list-style-type: none"> • Check thermal fuse. • If it is OK, check motor. • If motor is OK, check PC board.
03	Refrigerant system	09	<ul style="list-style-type: none"> • Gas shortage. (gas leak) • Other refrigerant cycle trouble. • Heat exchanger sensor off/break/short. • Overload relay break 	All off.	Indicated when detected abnormal.	<ul style="list-style-type: none"> • Check gas quantity. (Check gas leakage) • If it is OK, check heat exchanger sensor. • If heat exchanger sensor is OK, check overload relay. • If overload relay is OK, check refrigerant cycle. • If refrigerant cycle is OK, check PC board.
			12	Compressor break down.	All off.	Indicated when detected abnormal.

7-3. Troubleshooting Flowcharts

7-3-1. Power cannot be Turned on (No Operation at All)

<Preliminary checks>

- (1) Is the supply voltage normal?
- (2) Is the connection to the AC output O.K.?
- (3) Are the connection of the primary side and the secondary side of the power transformer inserted into the PC board?
- (4) Is the FUSE (F01) blown?

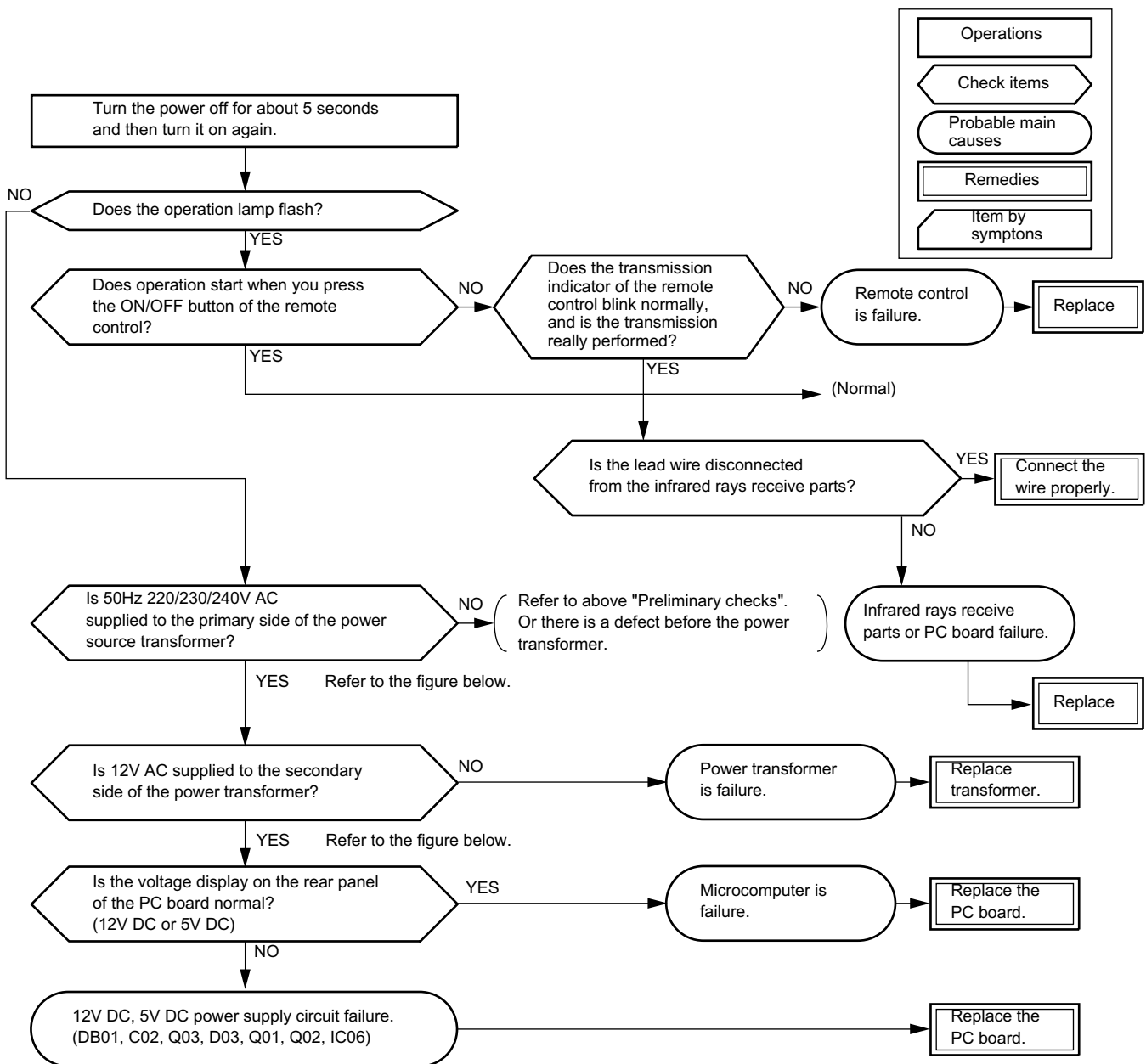

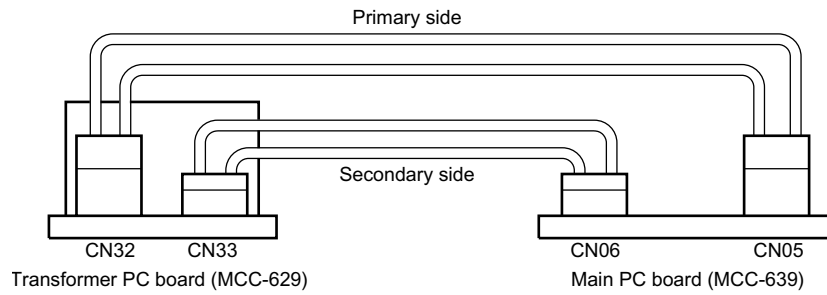
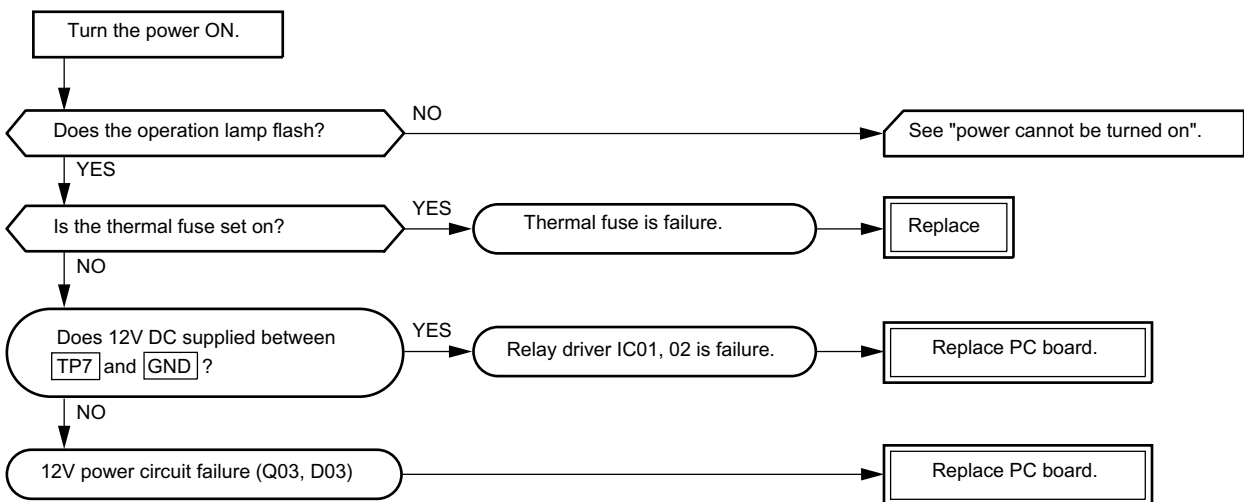

Fig. 7-2

7-3-2. Power Relay RY01 does not Operate.

Louver is not controlled automatically.



Note:

- When wiring to the thermal fuse has been broken, the TIMER lamp and OPERATION lamp will flash with 5 Hz.

7-3-3. Only the Indoor Fan does not Operate.

<Preliminary checks>

Does it neither work in COOL or FAN ONLY operation?

< Check procedure >

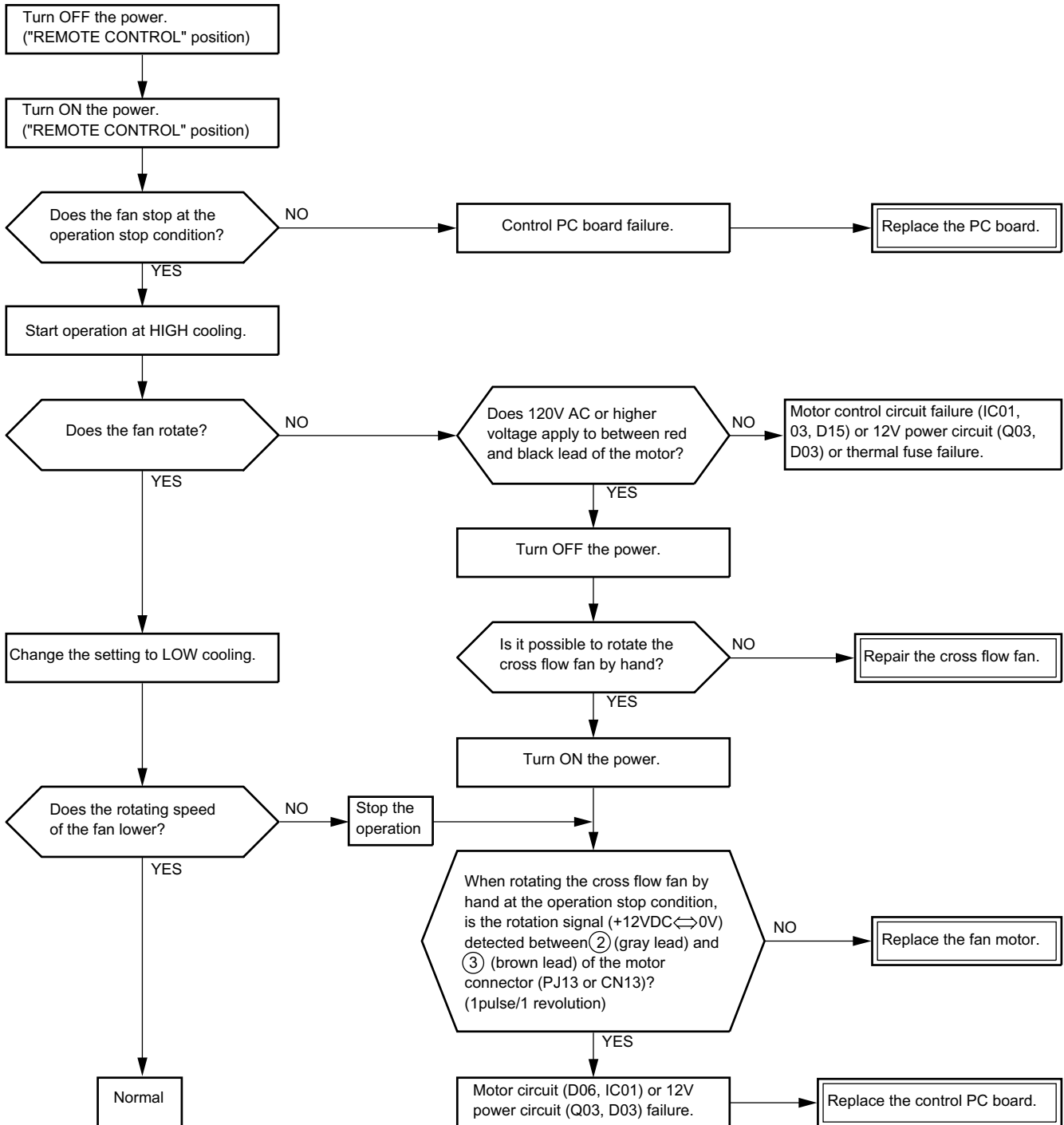

7-3-4. Compressor does not Operate.

< Preliminary checks >

- (1) Is the temperature set on the remote control higher than the room temperature in cool operation?
- (2) Is contact of the crossing wiring O.K.?

< Check procedure >

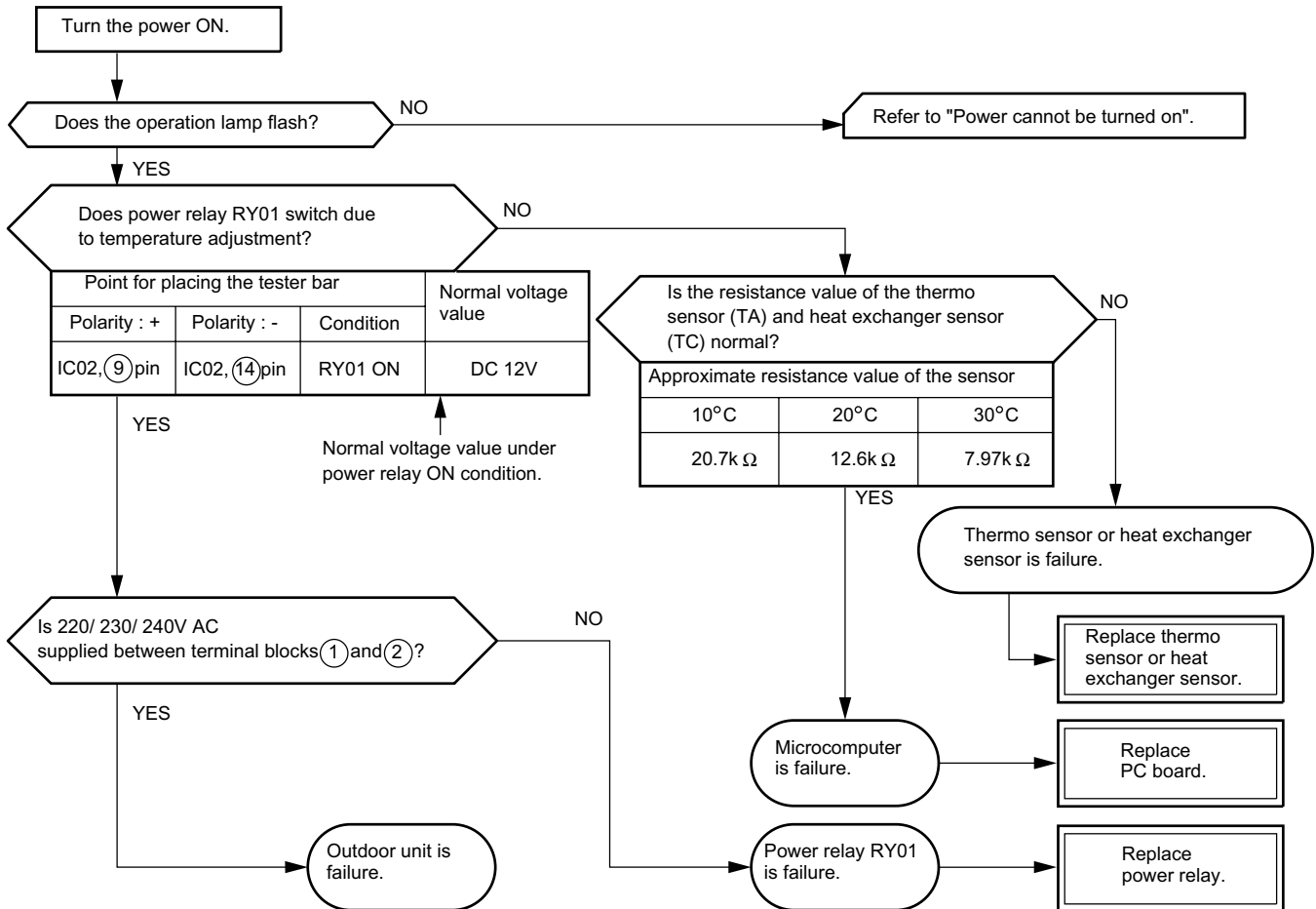

7-4. Test Points on the PC Board and List of Voltage Values

The test points (TP) are indicated on the rear of the PC board.

The voltage values on the test points for defect diagnosis items are listed below.

Table 7-6

Defect diagnosis item	Point for placing the tester bar			Normal voltage value
	Polarity (+)	Polarity (-)	Condition	
Does the power relay (RY01) switch?	IC02, 9 pin	IC02, 14 pin	When relay RY01 is ON.	12V DC (When relay is ON.)
Is the voltage of the secondary side of the transformer O.K.?	TP3	TP4	-	No load: 14 ± 2V With load: 12 ± 2V (Primary voltage is about 230V)
Is the voltage of the primary side of the transformer O.K.?	TP1	TP2	-	220-240V AC
Are both PTH terminals 5V AC or less?	Either end of PTH		-	5V AC or less: normal 5V AC or more: abnormal

7-5. How to Check the Remote Control (Including the Indoor PC Board)

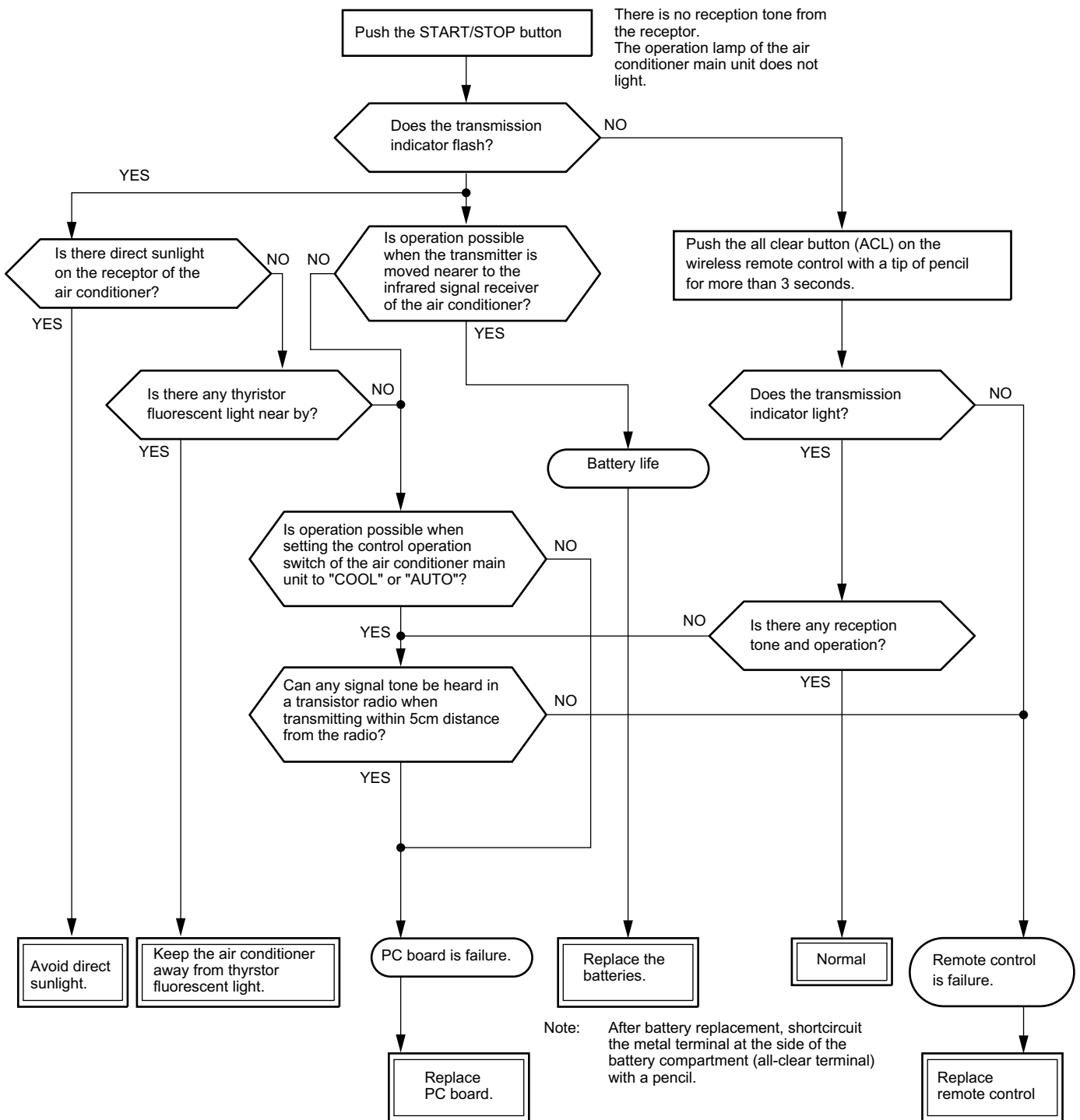

7-5-1. How to Check the PC Board

(1) Operating precautions

- 1) When removing the front panel or the PC board, be sure to disconnect the power plug from the AC outlet.
- 2) When removing the PC board, hold the edge of the PC board and do not apply force to the parts.
- 3) When connecting or disconnecting the connectors on the PC board, hold the whole housing. Do not pull at the lead wire.

(2) Inspection procedures

- 1) When a PC board is judged to be failure, check for disconnection, burning, or discoloration of the copper foil pattern or this PC board.

- 2) The PC board consists of the following 4 parts:

a. Main PC board part:

Power relay, indoor fan motor drive circuit and control circuit, C.P.U. and peripheral circuits, buzzer drive circuit and buzzer.

b. Infrared rays receive parts:

Infrared rays receiving circuit

c. Display: LED

d. Switch PC board:

Wireless-control, TEMPORARY switch

e. Buzzer PC board: Buzzer

f. Transformer PC board: Transformer

Check the defects of the PC board following the list below.

(3) Checking procedure

Table 7-7

Procedure	Check point (Symptom)	Trouble cause
<ul style="list-style-type: none"> • Disconnect the power plug from the AC outlet and remove the PC board assembly from the electronic parts base. • Remove the flat cable from the terminal plate. 	Is the fuse blown?	<ul style="list-style-type: none"> • Application of shock voltage • Short-circuit of the indoor fan motor
<ul style="list-style-type: none"> • Turn the power ON. • If the OPERATION lamp flash (0.5 sec. ON, 0.5 sec. OFF), steps 1 – 3 in the right column are not necessary. 	Check power supply voltage.	
	1. Between pins 1 and 3 of CN05 (220 – 240V AC)	• Defective power cord, power switch, fuse or line filter, or wrong wiring
	2. Between pins 1 and 3 of CN06 (12V AC)	• Defective power transformer
	3. Between TP6 (+5V) and GND (5V AC)	• Defective power circuit or short-circuited load
	4. Between TP7 (+12V) and GND (12V DC)	• Same as above
	5. Between TP8 (+12V) and GND (12V DC)	• Thermal fuse operation
Push the START/STOP button once to set in operation mode. (Do not set to the fan only or on-timer mode.)	Check power supply voltage.	
	1. Power relay coil voltage (12V DC) IC02, 9 pin and IC02, 14 pin	• Relay coil cable is broken, relay driver (IC181) is defective.
	2. Between terminals 1 and 2	• Relay contact is defective, SL connector is defective.
Start operation by using the anti-restart timer.	<ol style="list-style-type: none"> 1. All LEDs of the OPERATION lamp, the TIMER lamp, FAN ONLY lamp, ECONO. and AUTO lamp light up. 2. After 3 seconds, normal display does not appear. 	• Display is failure or defect in the 9P housing assembly.

Procedure	Check point (Symptom)	Trouble cause
Push the START/STOP button once to set in operation mode. 1. Setting the anti-restart timer 2. Cooling operation 3. Fan speed: AUTO 4. Set the temperature sufficiently lower than the room temperature. 5. Continuous operation	1. The compressor does not operate.	• The temperature of the indoor heat exchange unit is extremely low.
	2. The OPERATION lamp flashes.	• Defective control PC board.
Connect the motor connector to "MOTOR" and turn the power ON. Start operation as follows: 1. Set the operation mode to "FAN ONLY". 2. Set the fan speed to "HIGH". 3. Continuous operation	1. There is a voltage of 120V or more between the red and black motor connector leads.	• Indoor fan motor is failure.
	2. The motor does not rotate. (But the key operation of the remote control is accepted.)	• Contact of the motor connector is defective.
	3. Motor rotates but vibrates hard.	• Main PC board is failure.

Table 7-8 Approximate value of the sensor (thermistor) resistance (TA, TC)

Sensor \ Temperature	0°C	10°C	20°C	25°C	30°C
Thermo Sensor	35.8	20.7	12.6	10.0	7.92

(= kΩ)

7-5-2. How to Reduce the Operation Time of the Anti-restart Timer

- Drill 2 holes on the rear of the wireless remote control unit.
Attach the diode (1S1555 or equivalent) to the rivet inside the unit.
- Push the START/STOP button to start operation with the diode attached.

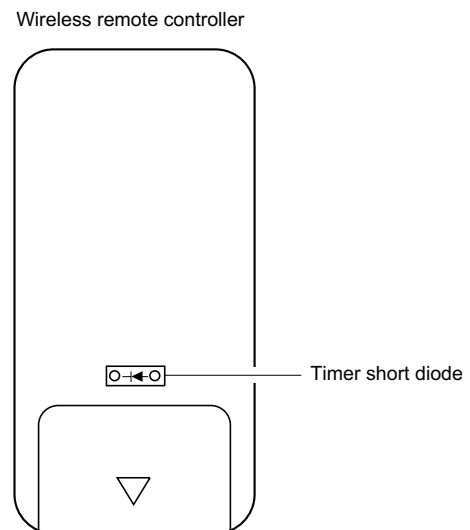

Fig. 7-3

7-6. PC Board Layout

Top view

Bottom view

8. EXPLODED VIEWS AND PARTS LIST

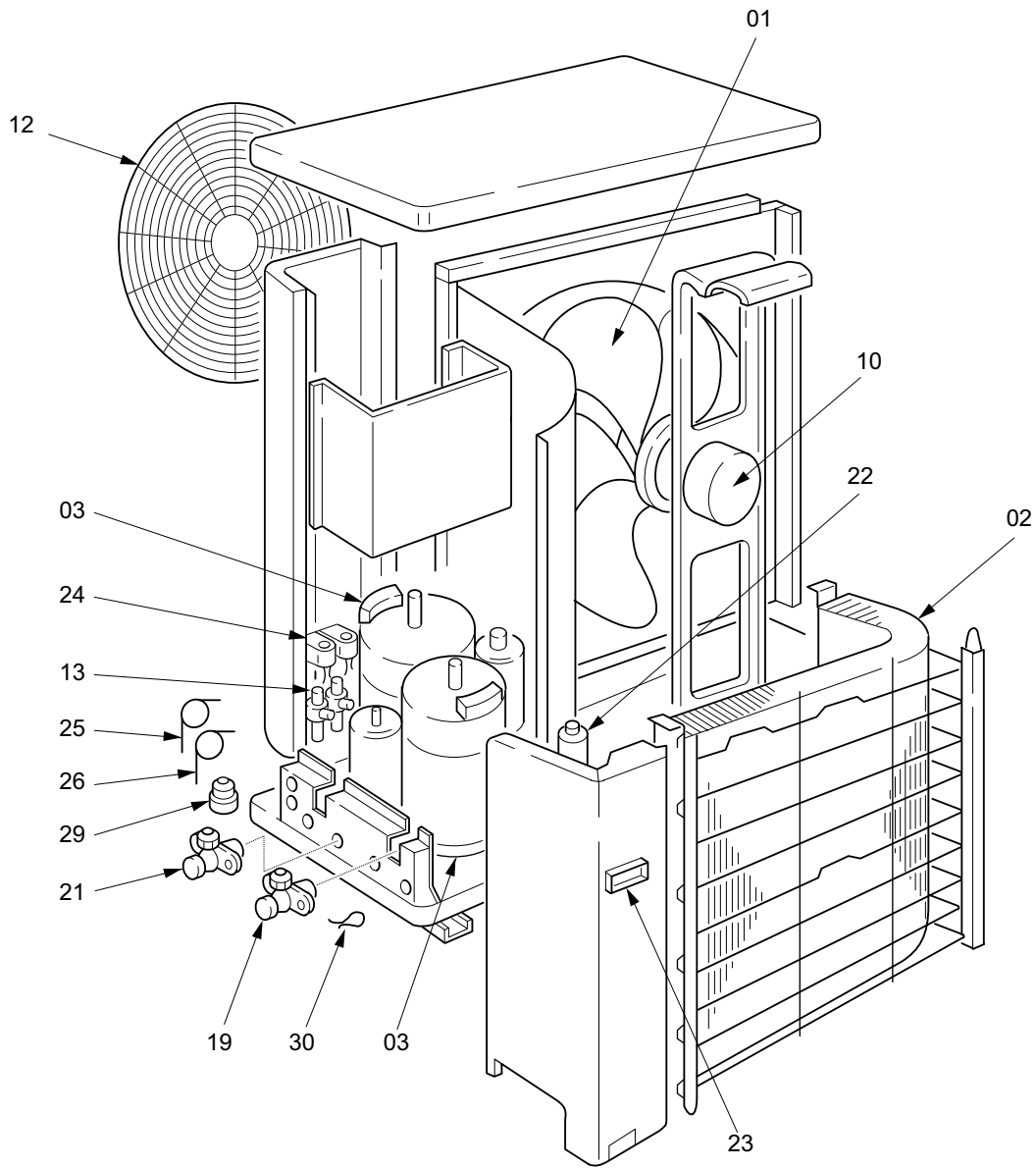

Location No.	Part No.	Description
01	43120168	Fan, Propeller
02	43143701	Condenser
03	43041728	Compressor, AC 220/240V, 50 Hz, PH160X2-4L
10	43121636	Motor, Fan, STF-200-63B
12	43191494	Guard, Fan
13	43046151	Valve, 2 Way
19	43046232	Packed Valve, 12.7

Location No.	Part No.	Description
21	43046228	Packed Valve, 6.35
22	43145103	Dryer
23	43119390	Hanger
24	43146443	Solenoid Coil
25	43047492	Capillary Tube, 1.7 Dia
26	43047491	Capillary Tube, 1.5 Dia
29	43049625	Cushion, Rubber
30	43066988	Holder, OL-Relay

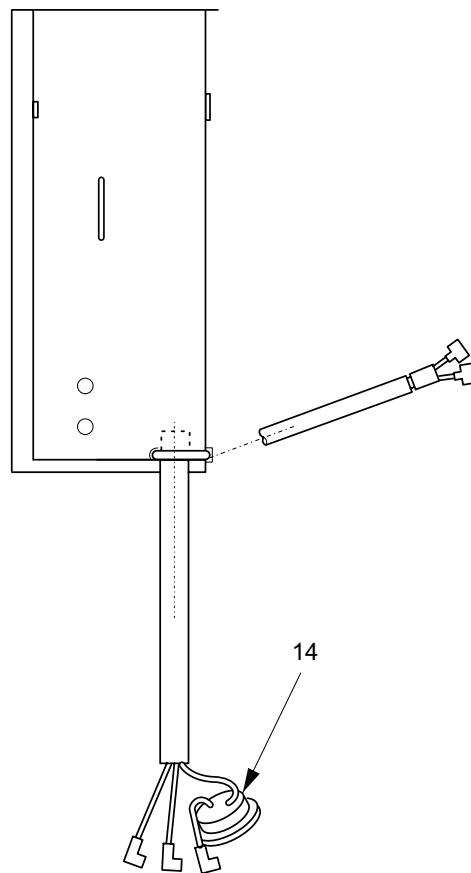
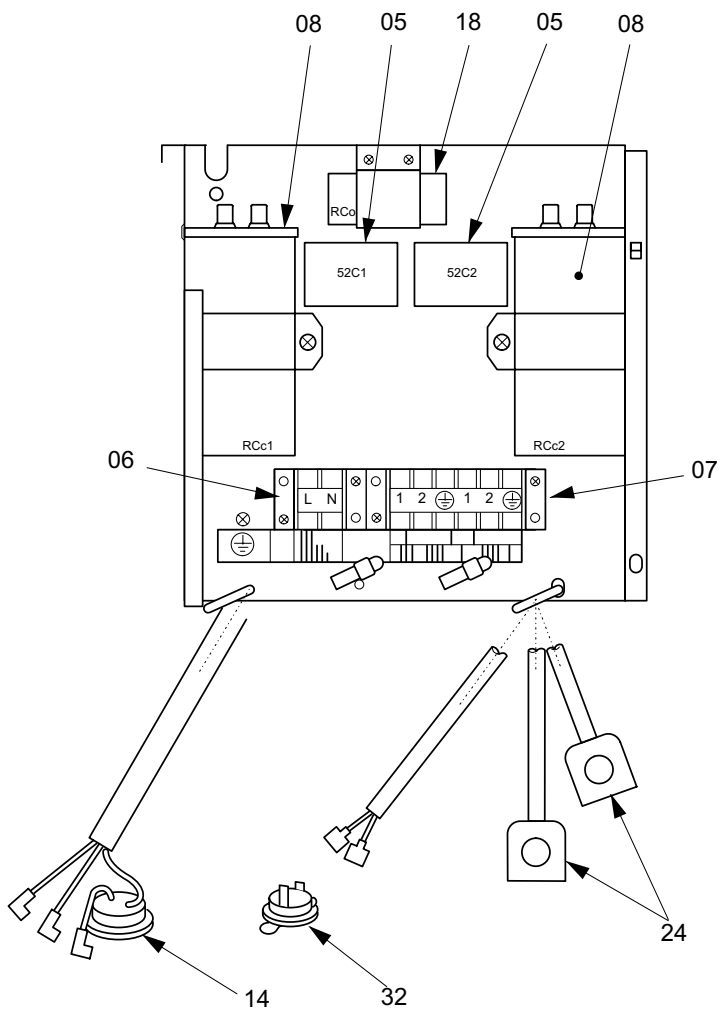

Location No.	Part No.	Description
05	43154139	Switch, Magnet
06	43160479	Terminal, Block, 2P
07	43160480	Terminal, Block, 6P
08	43055354	Capacitor, Plastic Film, 35MFD, 400V

Location No.	Part No.	Description
14	43054380	Relay, Overload
18	43155146	Capacitor, Electrolytic
24	43146443	Solenoid Coil
32	43150220	Bimetal Thermostat

MEMO

MEMO

TOSHIBA CORPORATION

1-1, SHIBAURA 1- CHOME, MINATO - KU, TOKYO 105 - 01, JAPAN