

SP-04.01 – FEBR. '04

MV-MVH 50

**START UP DELAY PC
BOARD RETROFIT KIT**

For the last version of the MV 50 (from S.N. 1233) it's now available a retrofit kit, to be installed on units in the field, that allows a two hours pre-start warm up of the compressor crankcase every time the machine is reconnected to the power line.

The New Start Up Delay PC Board Retrofit Kit is available under P/N CM 81453884 and consists off:

| | | |
|-------------------------|-----|-------------|
| Start Up Delay PC Board | P/N | CM 33580173 |
| By-pass Switch | P/N | CM 33400046 |
| Metal bracket | | |
| Warning Label | | |

The By-Pass switch allows to by pass the 2 hours pre-heating just moving it in ON position. It **MUST** be done **ONLY** by service technician as he **MUST** assure first, that compressor crankcase is at correct temperature.

We strongly recommend to retrofit in the field all the MV 50's equipped with the latest version of PC Board (from S.N. 1233) in order to avoid any possible compressor mechanical problem due to the compression/pumping of refrigerant in liquid state.

Attached we are pleased to sent you the Installation Instruction.

SCOTSMAN SERVICE TECHNICIANS

STARTING DELAY BOARD: ASSEMBLY KIT

SCHEDA RITARDO AVVIAMENTO: KIT DI MONTAGGIO

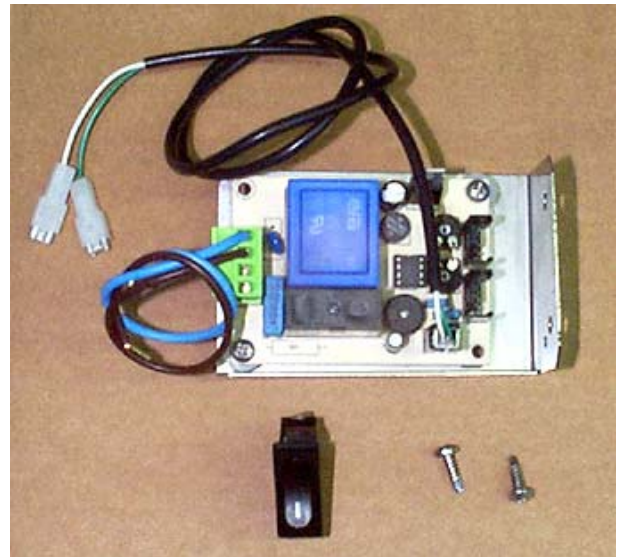

- ◆ Off-delay switch bracket
Staffa dell'interruttore di fine ritardo
- ◆ Starting delay board
Scheda ritardo avviamento
- ◆ Off-delay switch
Interruttore di fine ritardo
- ◆ Adhesive labels
Etichette adesive

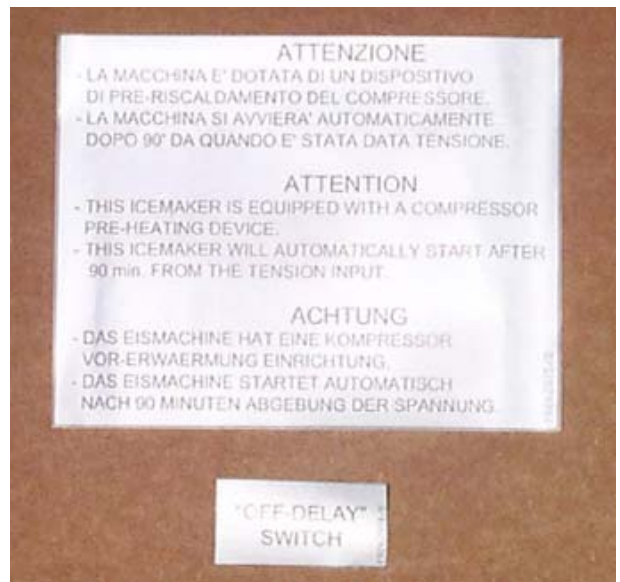

INTRODUCTION - *PREMESSA*

This kit is carried out for 500 kg modular icemakers and can be installed in the models with or without pre-heating switch.

Questo kit è previsto per i produttori di ghiaccio modulari da 500 kg e può essere installato nei modelli con o senza interruttore di pre-riscaldamento.

ASSEMBLY INSTRUCTIONS

- 1) a) **Models with pre-heating switch:** replace the pre-heating switch with the off-delay switch

NOTE: the disconnected cables of the pre-heating switch (“L1” terminal and main electronic board) **must not** be connected to the new switch (see point 3))

b) **Models without pre-heating switch:** drill the connections support as enclosed drawing code 71503476.0 (picture n° 1). Assemble the off-delay switch to the bracket and fix the whole to the connections support by the screws

- 2) Drill the electric box (compressor side) as enclosed drawing code 71510330.0 (picture n° 2)

- 3) Wire the starting delay board as enclosed electric diagram code :

• a) **models with pre-heating switch:** remove the pre-heating switch cable from the “L1” terminal

b) **models without pre-heating switch:** disconnect the main electronic board cable from the “L1” terminal

• connect the blue and brown cables of the delay board connector to the “N” and “L1” terminals (picture n° 3)

• connect the main electronic board cable to the delay board connector (picture n° 3)

• connect the black cable of the delay board to the off-delay switch (picture n° 4)

- 4) Fix the delay board to the electric box by the screws (picture n° 5)

- 5) Apply the labels “OFF-DELAY SWITCH” and “ATTENTION” near the switch and at the back of the machine (picture n° 6)

NOTE: remove the old labels relative to the pre-heating switch

ISTRUZIONI DI MONTAGGIO

- 1) a) **Modelli con interr. di pre-riscaldamento:** sostituire l'interruttore di pre-riscaldamento con l'interruttore di fine ritardo

NOTA: i cavi scollegati dell'interruttore di pre-riscaldamento (morsetto “L1” e scheda elettronica principale) **non** vanno collegati al nuovo interruttore (vedere punto 3))

b) **Modelli senza interr. di pre-riscaldamento:** forare il supporto attacchi come da disegno allegato cod. 71503476.0 (foto n° 1). Montare il pulsante di fine ritardo sulla staffa e fissare il tutto al supporto attacchi mediante le viti

- 2) Forare la scatola cablaggio (lato compressore) come da disegno allegato cod. 71510330.0 (foto n° 2)

- 3) Cablare la scheda ritardo avviamento come da schema elettrico allegato cod. 71510329.0:

• a) **modelli con interr. di pre-riscaldamento:** rimuovere il cavo dell'interruttore di pre-riscaldamento dal morsetto “L1”

b) **modelli senza interr. di pre-riscaldamento:** scollegare il cavo della scheda elettronica principale dal morsetto “L1”

• collegare i cavi blu e marrone del connettore verde della scheda ritardo rispettivamente ai morsetti “N” e “L1” (foto n° 3)

• collegare il cavo della scheda elettronica principale al connettore verde della scheda ritardo (foto n° 3)

• collegare il cavo nero della scheda ritardo all'interruttore di fine ritardo (foto n° 4)

- 4) Fissare la scheda ritardo alla scatola cablaggio mediante le viti (foto n° 5)

- 5) Applicare le etichette “OFF-DELAY SWITCH” e “ATTENZIONE” rispettivamente in prossimità dell'interruttore e sul retro della macchina (foto n° 6)

NOTA: rimuovere le vecchie etichette relative all'interruttore di pre-riscaldamento

Picture (Foto) n° 1

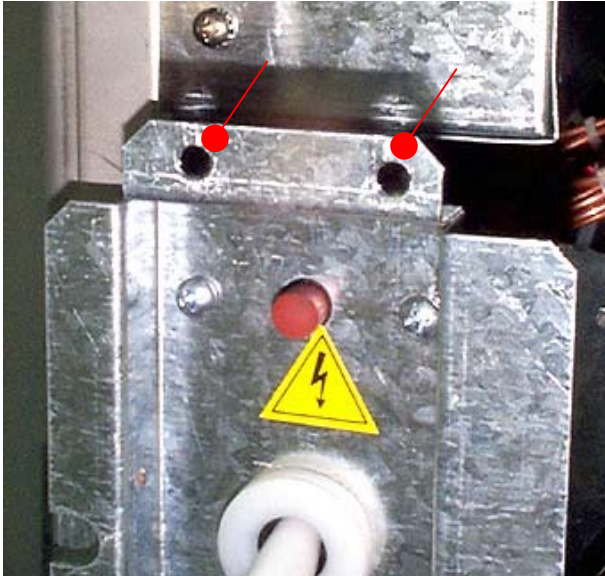

Picture (Foto) n° 2

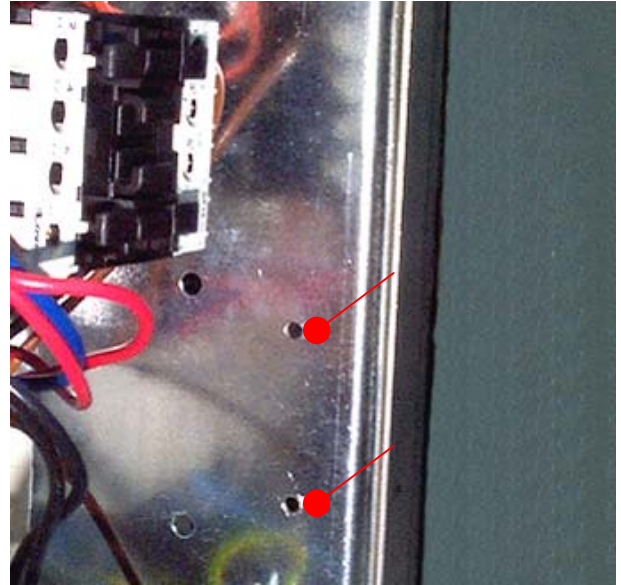

Picture (Foto) n° 3

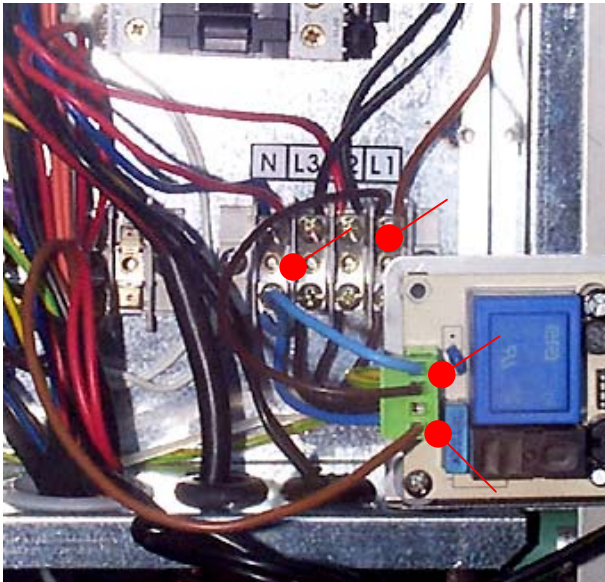

Picture (Foto) n° 4

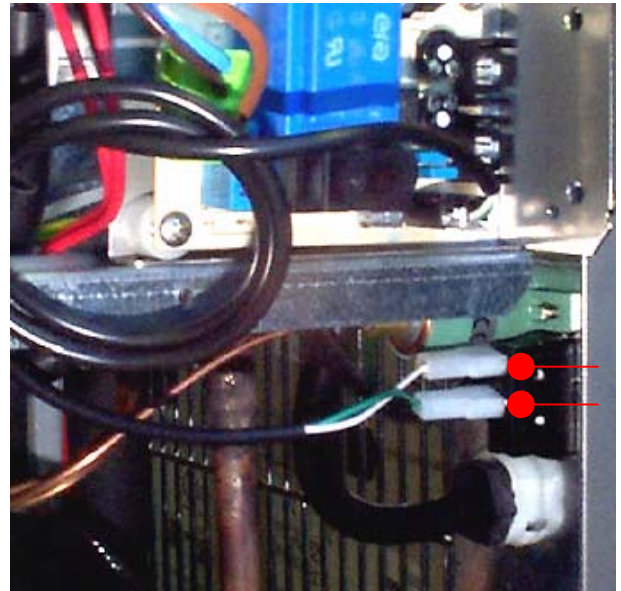

Picture (Foto) n° 5

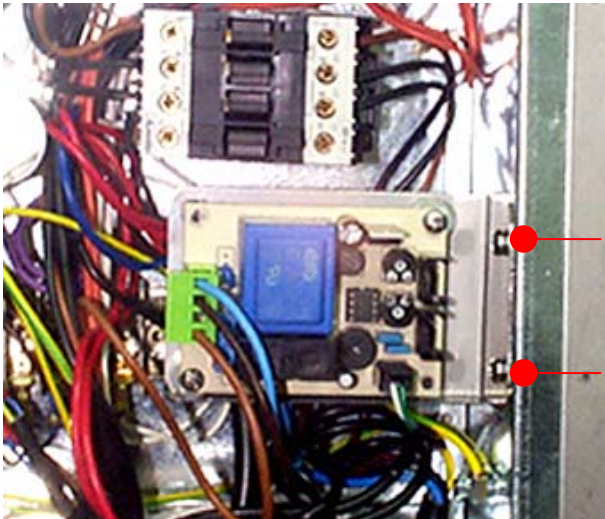

Picture (Foto) n° 6



CONNECTIONS SUPPORT / SUPPORTO ATTACCHI

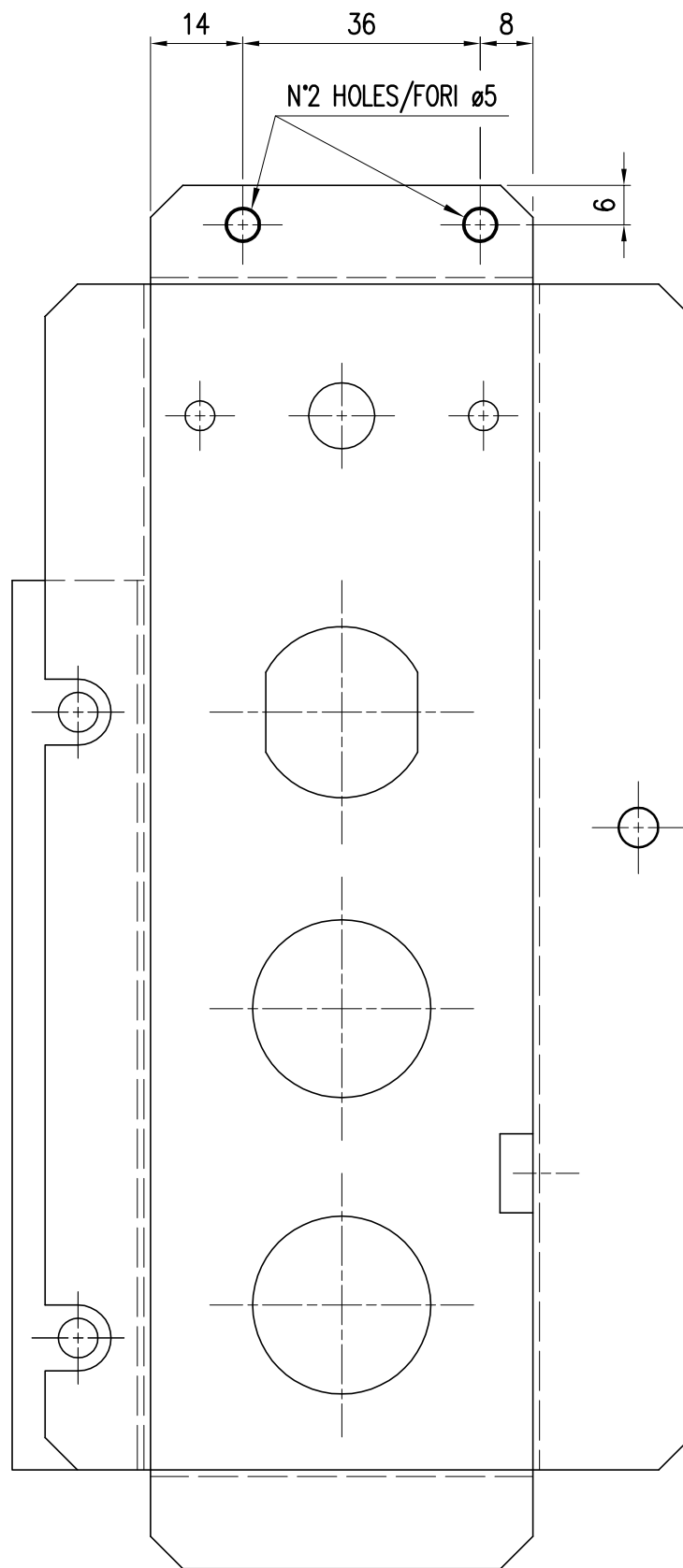

U.C ELECTRICAL BOX / SCATOLA CABLAGGIO U.C.

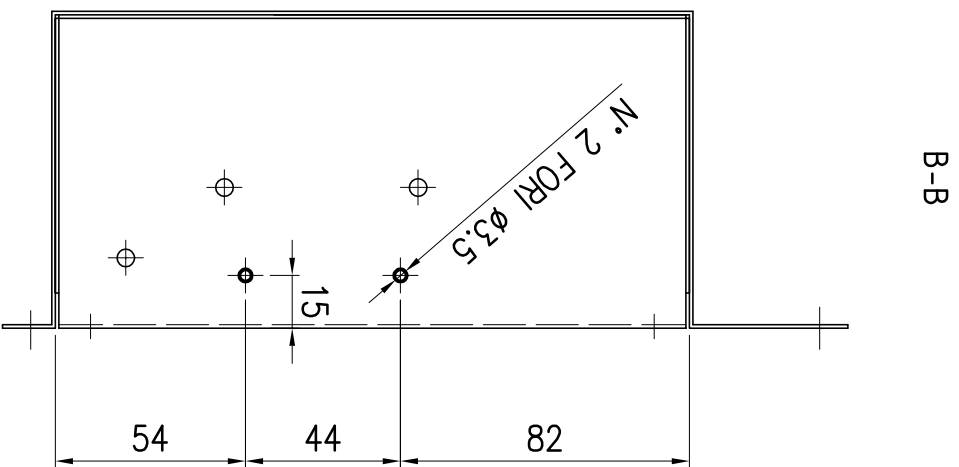
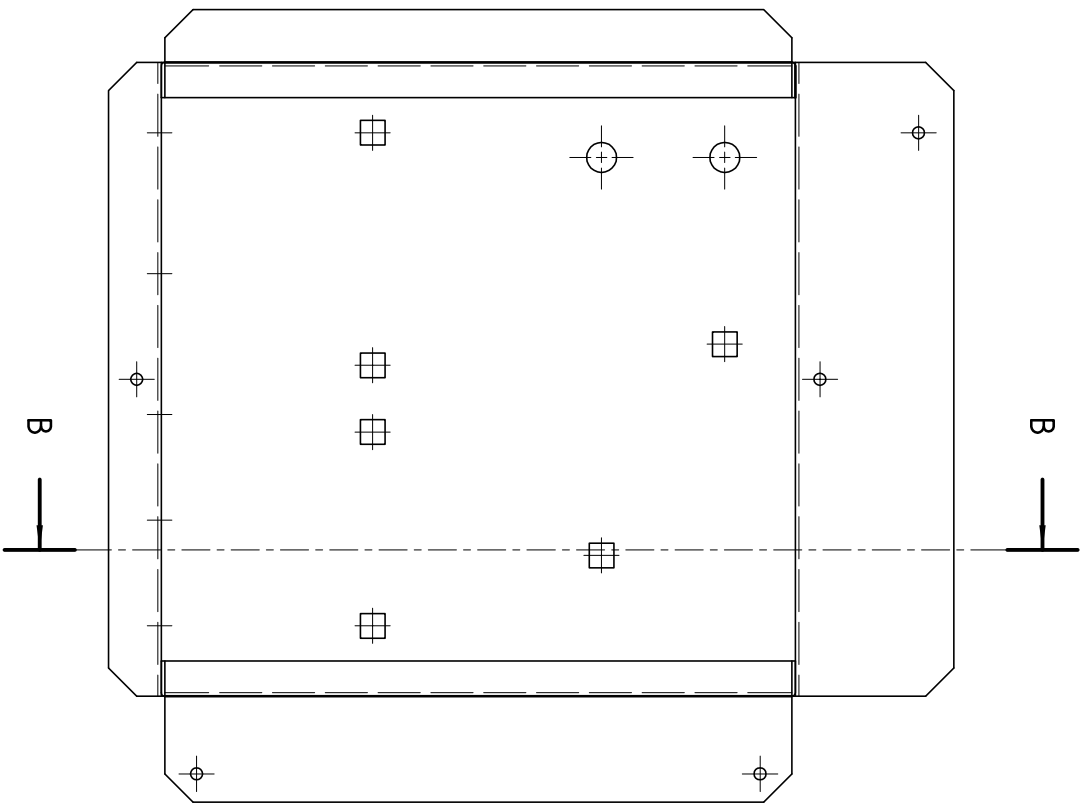

START DELAY ELECTRONIC BOARD CONNECTION DIAGRAM

SCHEMA COLLEGAMENTO SCHEDA ELETTRONICA RITARDO AVVIAMENTO

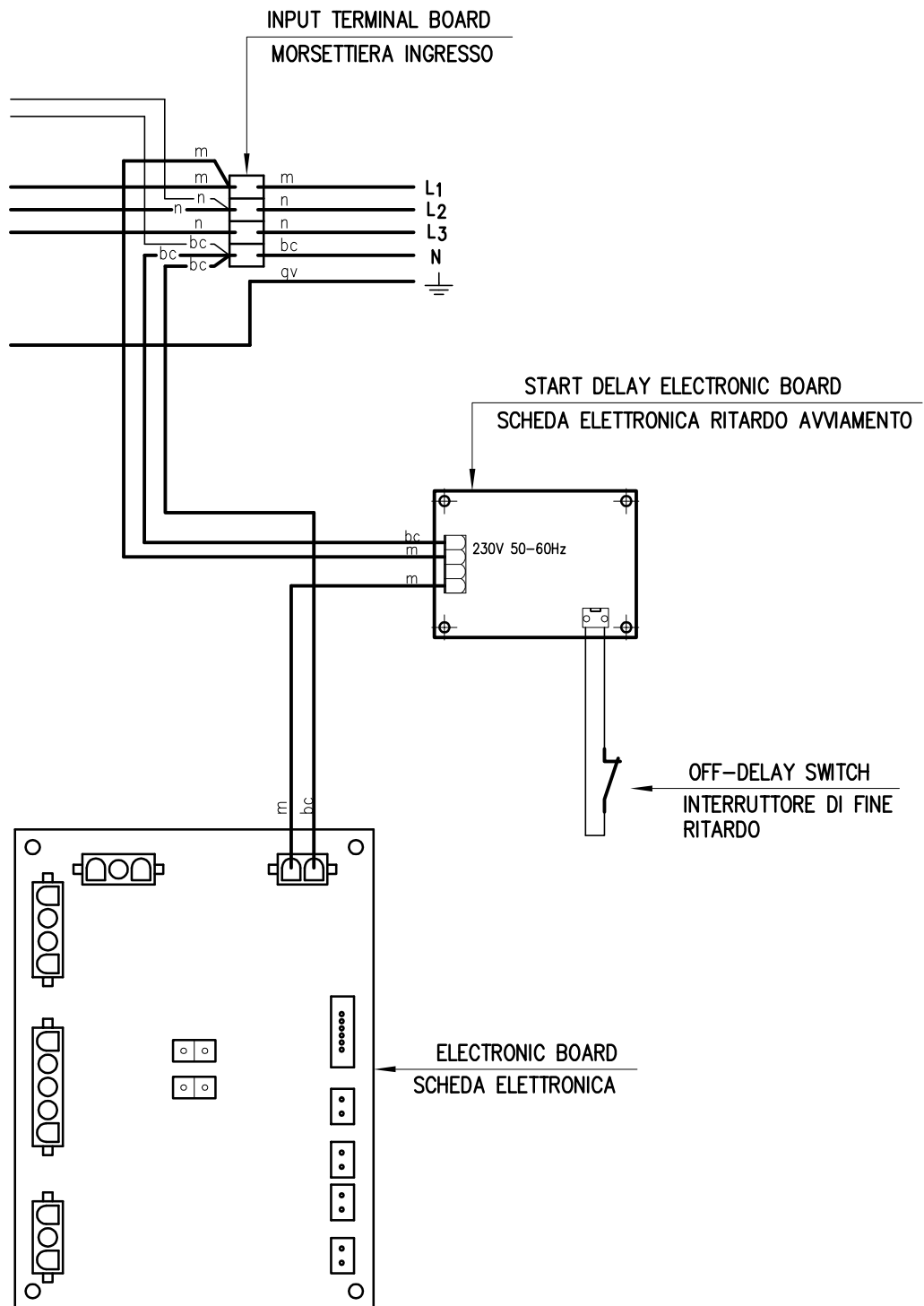

SP-04.02 – MARCH '04

AF 80

NEW LOCATION OF THE OPTICAL ICE LEVEL CONTROL

Starting from AF 80 s.n. 03260, the Optical Ice Level Control has been moved from the upper side of the plastic ice spout into the storage bin, just above the outlet of the plastic ice spout (see photo).



This modification increased the capacity of the storage bin by 5-6 kgs.

The installation of the Optical Ice Level Control on the new location has required a small modification on the upper side of the storage bin mold as well as the use on a new S.S. bracket P/N 724373 00.

NEW RELEASES

SP-04.03 – JUNE '04

AF 80

NEW OPTICAL ICE LEVEL CONTROL BRACKET KIT

As written on the previous Service Bulletin SP-04.03, the Optical Ice Level Control has been relocated in a different place inside the storage bin so to increase the level of the stored ice by 5-6 kgs.

Now, a new Retrofit Kit is available in order to modify, if needed, the machines in the field.

The new Optical Ice Level Control Bracket Retrofit Kit is available under **Part Number 060616 00** and it consists of the parts shown on the bottom photo.



NEW ICE LEVEL CONTROL BRACKET KIT

The metal bracket must be secured to the upper front side of the spout opening of the storage bin as detailed on the following photos after have drilled three holes as per attached drawing.



POSIZIONE DEI FORI PER KIT STAFFA ANCORAGGIO LETTORI OTTICI

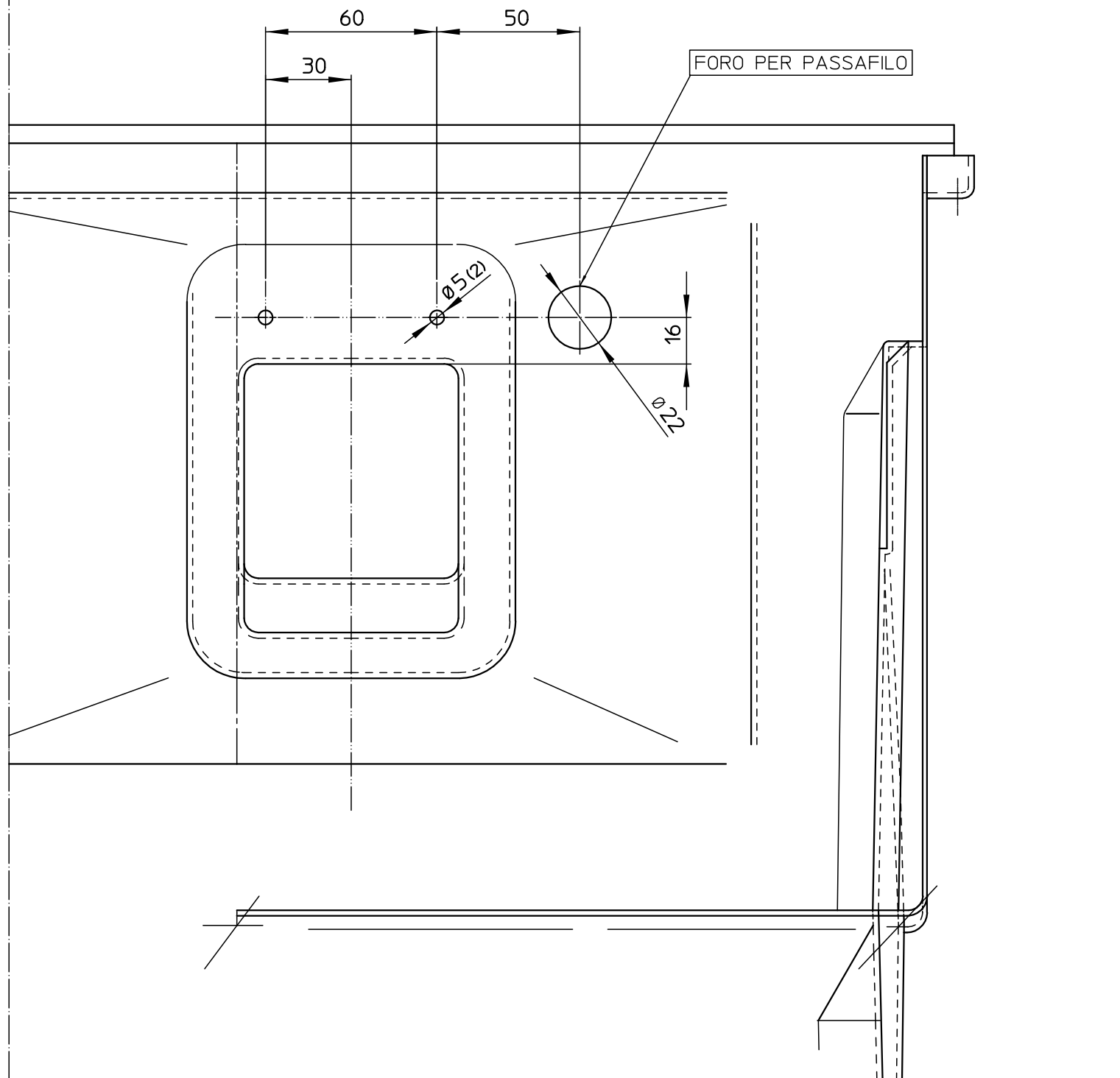

SP-04.04 – JUNE ‘04

MAR SERIES

NEW PLASTIC SPOUT

Starting from the following serial numbers:

| | | |
|---------------|------|------|
| MAR 71 SPLIT | S.N. | 1223 |
| MAR 101 SPLIT | | 2943 |
| MAR 121 SPLIT | | 1277 |
| MAR 55 | | 1707 |
| MAR 75 | | 1199 |
| MAR 105 | | 2654 |

The previous plastic ice spout P/N 660478 00 has been replaced with a new type as shown on the attached drawing (item 8) and available under **Part Number 660723 00**.

The new plastic spout is NOT exchangeable with former.

Shortly the same modification will be released for the remaining units i.e:

MAR 201 SPLIT
MAR 301 SPLIT

MAR 125
MAR 205
MAR 305

NEW PLASTIC SPOUTS

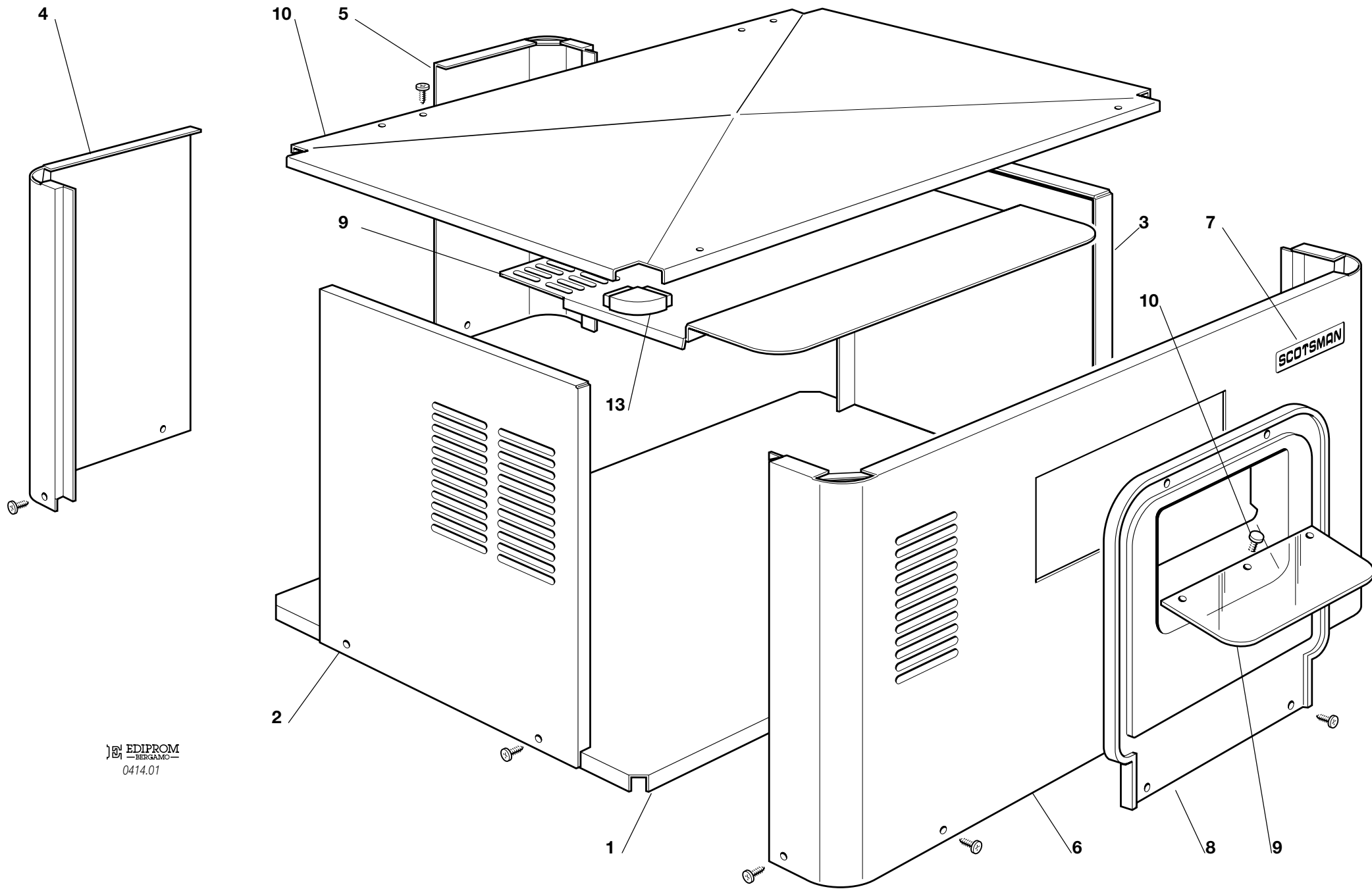

EDIPROM
BERGAMO
0414.01

SP-04.05 – JUNE '04

MC 45 – WATER COOLED

NEW COPPER WATER TUBES

Starting from the serial number 23599, the plastic water tubes connecting the water cooled condenser to the water inlet and outlet fittings have been replaced with copper tubes as shown on the here below photos.

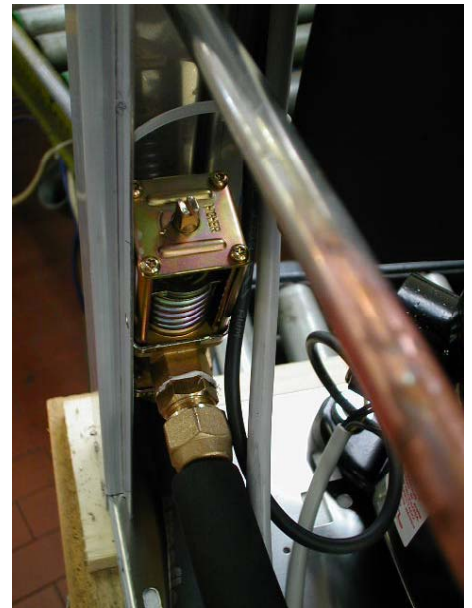
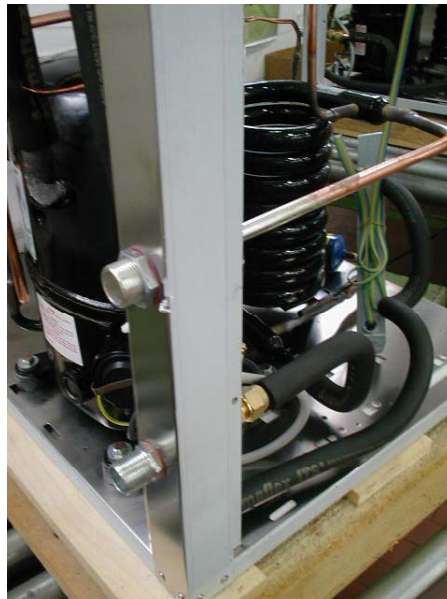

The Part Numbers of the new components are:

| | | |
|--------------------------|-----|-----------|
| 3/4 water inlet fitting | P/N | 733204 00 |
| Fiber washer (inlet) | | 400031 01 |
| Nut (inlet) | | 400085 02 |
| 1/2" male flared fitting | | 733208 02 |
| Water regulating valve | | 620111 00 |
| 3/4 water outlet fitting | | 733205 04 |
| Fiber washer (outlet) | | 400052 00 |
| Nut (outlet) | | 400053 00 |

Shortly the same modification will be implemented also on MC 15 and MC 1210.

NEW RELEASE

SP-04.06 – JUNE ‘04

MF 82-102

NEW GEAR MOTOR ASSY

Starting from the following serial numbers:

| | | |
|---------------|-------------|--------------|
| MF 82 | S.N. | 03776 |
| MF 102 | | 01126 |

the previous gear motor and gear reducer has been replaced with a new bigger one, see bottom photos, in order to assure it a longer last.



**NEW
MOTOR
REPLACEMENT**

The new Gear Motor Assy (**gear reducer + gear motor already assembled** - Bonfiglioli VF/W49/110) is available under **Part Number 620480 00** while **the Drive Motor only** under Part Nbr **620480 01**.

As we are receiving the gear reduce with the drive motor already assembled from supplier with this new type of gear motor it's NOT possible to have ONLY the Gear Reducer as on the former verison.

The new Gear Motor Assy can be installed on former version of MF 82-102 with small modification on the unit base (new position of the four securing holes) as detailed on the attached drawing.

To modify the old MF 82-102 a **Gear Motor Assy Retrofit Kit** will be available shortly under **Part Nbr 060615 00** that will include all the necessary parts for the conversion i.e.:

| | | |
|-------------------|-----|-----------|
| Gear motor assy | P/N | 620480 00 |
| Output shaft | | 704255 00 |
| Plastic drip tray | | 660764 00 |
| Metal key (2 pcs) | | 460043 00 |

As soon as we'll run out of stock with the old Zambello gear reducer, we'll automatically supply the new Gear Motor Assy Retrofit Kit.

From the same serial numbers a sequence phase relay P/N has been added on the control box electrically connected in series with the gear reducer drive motor.



In case of wrong rotation the sequence phase relay trip OFF immediately the operation of the drive motor. If so two phases MUST be inverted on unit plug.

Attached please find the drawing showing the new location of the securing holes of the S.S. unit base.

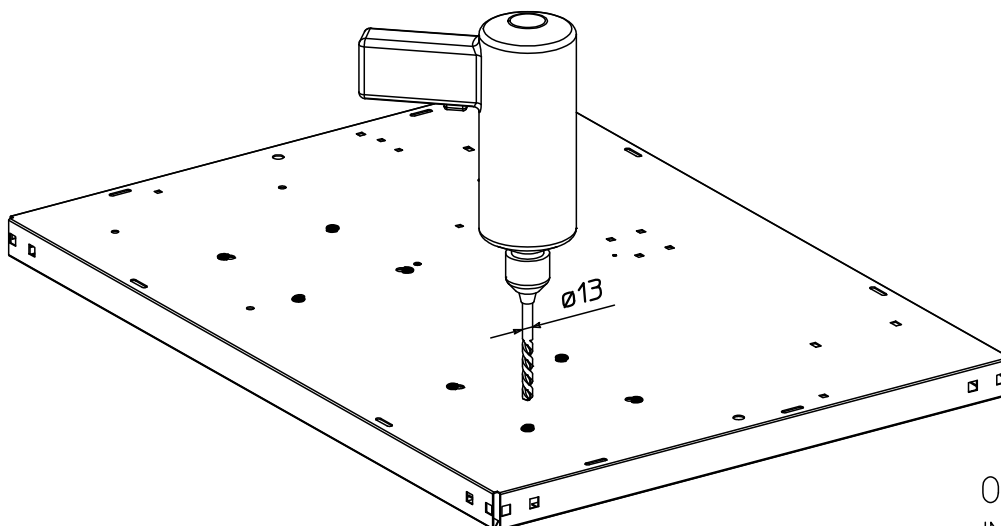
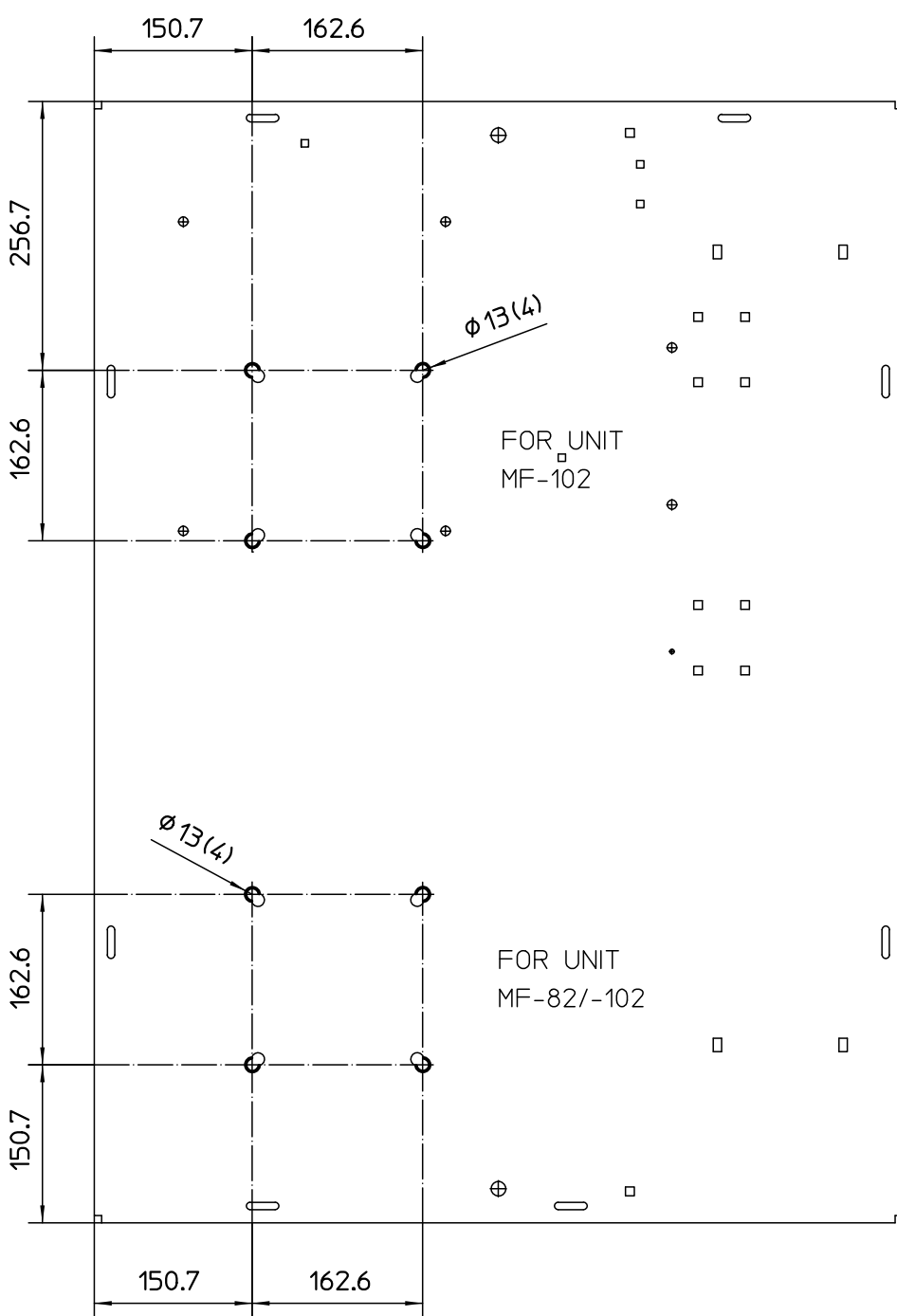

SP-04.07 – JULY '04

AF-MF

PC BOARDS

As detailed on the Service Manual of our AF and MF Flaker Series, the jumper J1 is used to energize the whole electrical parts of the machine during the earth leak test performed at the end of the assembly line.

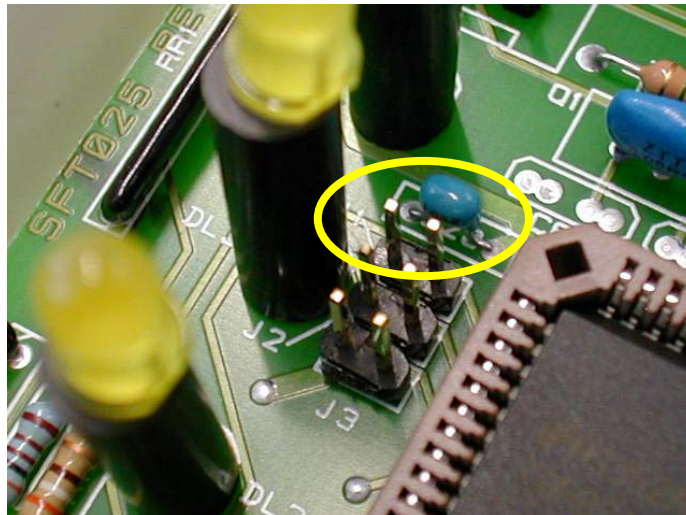

In case the two contacts of this jumper are connected together, the machine remain in operation for maximum 5 minutes without noticing any possible alarm condition.

At the end of the 5 minutes the PC Board trip OFF the operation of the entire machine with the blinking of all PC Board yellow and red leds.

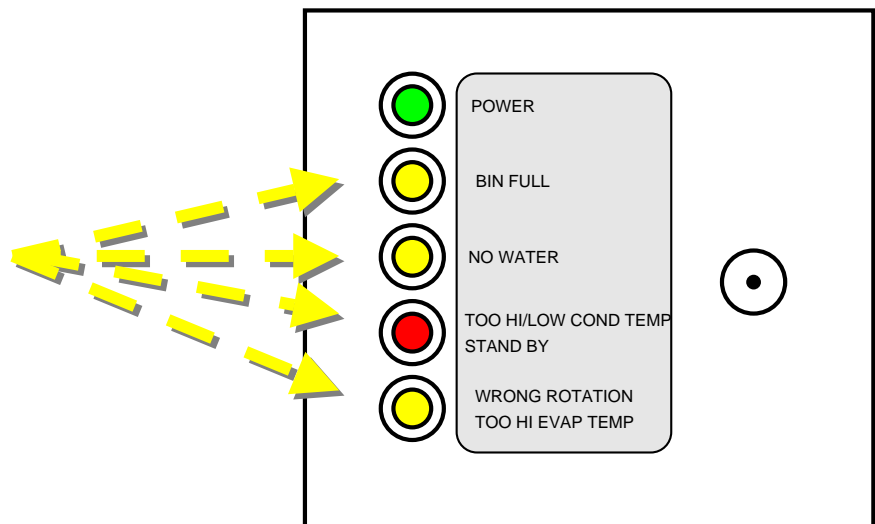

NEW
MACHINE
SERIES

SP-04.08 – JULY '04

MAR 55-75-105-125

MAR 71-101-121 SPLIT

NEW TEFLON CHUTE

Starting from the following serial nbrs:

| | | |
|---------|------|-------|
| MAR 55 | S.N. | 01716 |
| MAR 75 | | 01207 |
| MAR 105 | | 02662 |
| MAR 125 | | 01218 |

| | | |
|---------------|------|-------|
| MAR 71 SPLIT | S.N. | 01230 |
| MAR 101 SPLIT | | 02955 |
| MAR 121 SPLIT | | 01278 |

the former plexiglass chute has been replaced with a new one in teflon in order to assure a better sliding of the scale ice as shown on below photo.



Few machines equipped with the new teflon ice chute have been in operation since months reporting us a much lower accumulation of ice around the plastic buttons used to hold the chute on the S.S. scraping blade.

**NEW
TEFLON
ICE
CHUTE**

Together with the new teflon ice chute we have take the opportunity to modify also the holding buttons moving to new smaller ones.

The new part numbers are:

| | | |
|------------------|-----|-----------|
| Teflon ice chute | P/N | 741120 01 |
| Plastic button | | 650871 00 |

A retrofit kit P/N 060618 00, consisting of the above listed parts plus a S.S. spacer for the new smaller plastic buttons will be available soon as service parts.

For the installation of the S.S. spacer it is necessary to use some Loctite to be sure of the correct contact as shown on the bottom photo.



As soon as we'll run out of stock of former plexiglass ice chutes, the new retrofit kit will be supplied.

Shortly the same modification will be made also on bigger MAR units i.e. MAR 201-205-301-305.

SP-04.09 – JULY '04

AF SERIES – TC 180

MF 22 – MF 30

**NEW GEAR REDUCER
PLASTIC DRIP TRAY**

Starting from the following serial nbrs:

| | | |
|--------|------|-------|
| AF 80 | S.N. | 03486 |
| AF 100 | | 25368 |
| AF 200 | | 02109 |
| AF 20 | | 11893 |
| AF 30 | | 09351 |
| MF 22 | S.N. | 02495 |
| MF 30 | | 14738 |
| TC 180 | S.N. | 02489 |

the previous gear reducer metal drip tray has been replaced with a new plastic one of different shape and equipped with an overflow located below the output shaft oil seal level, as detailed on the bottom photos.

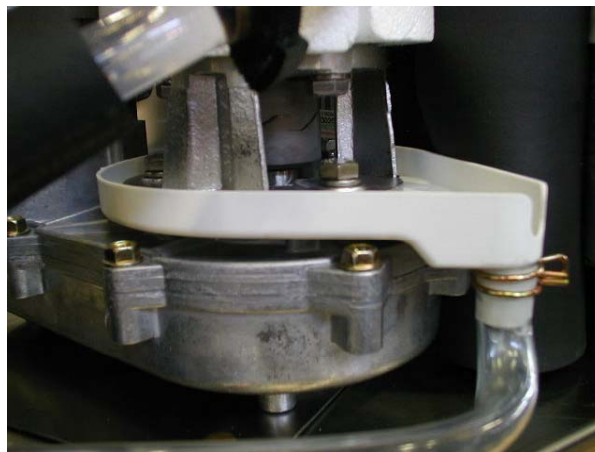

The new plastic drip tray is available under P/N 660756 00 and it's exchangeable with former one with partial modification of the plastic drain hose.

Shortly the same modification will be introduced also on MF 41-51-52-62 and MFE 61.

**NEW
MACHINE
SERIES**

SP-04.10 – SEPT '04

CD 40

**NEW GREY DISPENSER
FRAME AND FRONT LINERS**

Starting from the CD 40 serial nbr 3356, the Dispenser Frame as well as the four Front Plastic Liners have been changed in their color moving from Blue to Grey so to better match the grey color of the cabinet/panels as shown on the here below photo.



The new grey plastic parts are available under the following part numbers:

| | | |
|-----------------------|-----|-------------|
| Dispenser Frame Assy | P/N | CM 81409161 |
| Front Plastic Liner | | CM 25620336 |
| Grey Dispensing Label | | CM 19262586 |

In addition, a Dispenser Frame assy & Front Liners Kit, to up to dated the old blue versions, is available under P/N CM 81409163.

NEW RELEASE

SP-04.11 – SEPT '04

MAR 201-301-205-305

NEW PLASTIC SPOUT

As done in June with the smaller series of the MAR machines, also the larger one has been modified in the plastic spout.

Starting from the following serial numbers:

| | | |
|---------------|------|------|
| MAR 201 SPLIT | S.N. | 2453 |
| MAR 301 SPLIT | | 2662 |
| MAR 205 | | 2483 |
| MAR 305 | | 1276 |

the previous plastic ice spout P/N 660478 01 has been replaced with a new type available under **Part Nbr 660724 00**.

This new plastic spout is NOT exchangeable with the former one.

The use of the new plastic spout required some small/minor modifications of the back panel.

New back panel, Part Nbr 784503 07, is exchangeable with the former one but NOT the contrary.

NEW PLASTIC SPOUTS

SP-04.12 – SEPT ‘04

MAR 201-301-205-305

NEW TEFLON CHUTE

As already done with the smaller series of the MAR machines, also on the larger one is now used a teflon chute in place of former plaxiglass type.

The new teflon chute, that assures a better sliding of the scale ice, has been installed starting from the following serial numbers:

| | | |
|---------------|------|------|
| MAR 201 SPLIT | S.N. | 2453 |
| MAR 301 SPLIT | | 2662 |

| | | |
|---------|--|------|
| MAR 205 | | 2483 |
| MAR 305 | | 1276 |

The new teflon chute P/N 741120 00, perfectly exchangeable with the former one, it's secured to the scraping blade by means of the same plastic plugs used till now P/N 650595 00.

SCOTSMAN ICE MACHINES

SP-04.13 – OCT '04

MAR SERIES

NEW CASTING IRON PULLEYS

Starting from the following serial numbers:

| | | |
|---------|------|------|
| MAR 55 | S.N. | 1732 |
| MAR 75 | | 1215 |
| MAR 105 | | 2678 |
| MAR 125 | | 1227 |
| MAR 205 | | 2585 |
| MAR 305 | | 1278 |

| | | |
|---------------|------|------|
| MAR 71 SPLIT | S.N. | 1251 |
| MAR 101 SPLIT | | 1979 |
| MAR 121 SPLIT | | 1303 |
| MAR 201 SPLIT | | 2456 |
| MAR 301 SPLIT | | 2671 |

the former aluminum pulleys have been replaced with new casting iron ones as shown on the here below photo.

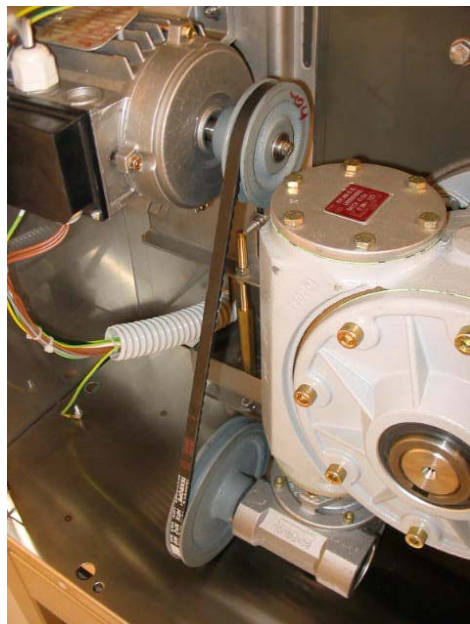

NEW
MACHINE
SERIES

As new drive motor pulley in casting iron has only one groove and no more two as former aluminum one, with all MARs, except MAR 125 and MAR 121 Split, a second drive motor pulley (larger diameter) is standard supplied with the machine secured to the bottom of the evaporator base (see photo below).

This larger pulley must be used in place of the standard one when end user needs thin ice rather than thick ice.



In order to assure a better contact between V belt and the groove of drive motor pulley (when small diameters are used) the former V belt Z section has been replaced with a new toothed one (XPZ section).

On the bottom chart you can find the part nbrs of new casting iron pulleys as well as new XPZ V belts.

| | Drive motor pulley thick ice | Drive motor pulley thin ice | Gear reducer pulley | XPZ V belt |
|--------------------|-------------------------------------|------------------------------------|----------------------------|-------------------|
| MAR 55 | 650879 01 | 650879 03 | 650879 10 | 650878 00 |
| MAR 71/75 | 650879 02 | 650879 03 | 650879 10 | 650878 00 |
| MAR 101/105 | 650879 05 | 650879 09 | 650879 10 | 650878 01 |
| MAR 121/125 | 650879 07 | XXXXX | 650879 10 | 650878 01 |
| MAR 201/205 | 650879 00 | 650879 04 | 650879 08 | 650878 01 |
| MAR 301/305 | 650879 05 | 650879 09 | 650879 08 | 650878 02 |

SP-04.14 – OCT '04

MC 15 – WATER COOLED

NEW COPPER WATER TUBES

As already done on June '04 with MC 45's, also on models MC 15 the former plastic tubes, connecting the water cooled condenser to the water inlet and outlet fittings, have been replaced with copper ones.

The modification, on the water cooled system, starts from MC 15 **Serial Nbr. 16666**.

The part nbrs, of new components, are the same of the ones used on MC 45 i.e.:

| | | |
|------------------------|-----|-----------|
| ¾ water inlet fitting | P/N | 733204 00 |
| Fiber washer (inlet) | | 400031 01 |
| Nut (inlet) | | 400085 02 |
| ½" male flared fitting | | 733208 02 |
| Water regulating valve | | 620111 00 |
| ¾ water outlet fitting | | 733205 04 |
| Fiber washer (outlet) | | 400052 00 |
| Nut (outlet) | | 400053 00 |

NEW
SERIES
ICE
MACHINE

SP-04.15 – OCT '04

MAR SERIES

PLASTIC SPOUT COVER

As you certainly know, from now on, all MAR units (Compact and Split) will be standard supplied with the new plastic spout cover available under Accessory Code Numbers:

COVERMARS0000 **MAR 55-75-105-125 – MAR SPLIT 71-101-121**
COVERMARL0000 **MAR 205- 305 – MAR SPLIT 201- 301**

In case of need of the same as spare part the Part Nbrs of Cover only and its Inspection Panel are:

| | | |
|---------------------------|------------|------------------|
| COVER ONLY - SMALL | P/N | 660723 01 |
| COVER ONLY - LARGE | | 660724 01 |
| INSPECTION PANEL | | 660742 00 |

As detailed on below photo.



NEW
SERIES
ICE
MACHINE