

marco



POURING PERFECTION

Marco Beverage Systems Ltd.

INSTRUCTIONS FOR MODELS

ECOBOILER ECOSMART PB10

(P/N: 1000677, 1000678)

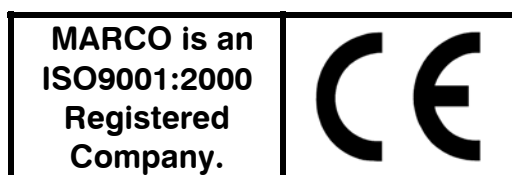

Water pressure : 5 - 50 psi (min.-max.)35 - 345 kPa (min.-max.)

Marco Beverage Systems Limited. 63d Heather Road, Sandyford Industrial Estate, Dublin 18.	Marco Beverage Systems Limited. Shire House, Strixton Manor, Strixton, Wellingborough, Northants, NN29 7PA
Ireland Tel: +353 (0)1 295 2674 Ireland Fax: +353 (0)1 295 3715 email: sales@marco.ie www.marco.ie	UK Tel: +44 (0)2072 744 577 UK Fax: +44 (0)2079 788 141 email: sales@marco-bev.co.uk www.marco-bev.co.uk

SAFETY:

- This appliance must be earthed. If the moulded plug supplied is not used then ensure that the green/yellow cable is connected to a suitable earth.
- Risk of flooding. The hose supplied with this unit is non-toxic food quality tested to 190psi. However, a hose is not a permanent connection. It is, therefore, advisable to switch off boiler and close the stopcock valve when boiler is not in use, e.g. overnight, weekends etc.
- Risk of scalding. Beware of accidentally operating the water drawoff tap or push button especially when cleaning the front of the boiler.
- The utmost care has been taken in the manufacture and testing of this unit. Failure to install, maintain and / or operate this boiler according to the manufacturer's instructions may result in conditions that can cause injury or damage to property. If in any doubt about the serviceability of the boiler always contact the manufacturer or your own supplier for advice.
- This appliance is not intended for use by persons (including children) with reduced physical, sensory, or mental capabilities, or lack of experience and knowledge, unless they have been given supervision or instruction concerning use of the appliance by a person responsible for their safety.
- Children should be supervised to ensure that they do not play with the appliance
- In the event any wires are damaged, such wires can only be replaced by experts or professional afterservice staff from the manufacturer, afterservice department or similar function departments

INSTALLATION DETAILS:

Electrical installation:

- Electrical specification: 2.8kW-230V-50Hz
- A moulded 13A plug is factory fitted. A suitable 13A outlet is all that is required.

Plumbing installation procedure:

- Mains water pressure required (limits): 5-50psi (35-345kPa)
- Fit a stop Valve on a cold water line and attach a 3/4" BSP male fitting,
- (e.g. 3/4" x 1/2" 311 or washing machine type stop valve).
- Connect straight tailpiece of the hose to the stop valve fitting. Make sure that the pre-attached sealing washer is fitted.
- Turn on the water to flush any impurities, dust etc from the inlet hose and water pipe. Allow several gallons through.
- Connect right-angled tailpiece of the hose to the inlet valve of the boiler (again 3/4" BSP). Make sure the sealing washer is fitted here also.
- Turn on water and check for leaks.

Operating boiler for the first time:

- Check that all installation procedures have been carried out.
- Ensure water valve is on.
- Plug boiler into 13A socket and press power button on the front of the machine marked 'Power'. Refer to Figure 1.
- The "power on" light will glow green and the machine will fill to a safe level, above the elements, before heating. The display will show the current water temperature and the status "Filling..."
- The "Ready/Status" light will cycle two red flashes while the machine is filling to the safe level.
- After this amount of water has heated to about 96°C the boiler will draw more water in until the temperature drops by 1 or 2 degrees. The boiler will then heat again. This heat fill cycle continues until the boiler is full.
- While filling, the "Ready/Status" light will remain blank.
- The "Ready/Status" light will glow green when the machine is both full and up to normal operating temperature. For 10L machines allow approx 30 minutes.

- The boiler is now ready for use – the display will show the Water Temperature and the status “READY”.
- The Boiler may now be used to dispense Hot Water to the preset factory settings.
 - 94°C
 - Push and Hold operation
 - Continuous flow – no pulsing
 - Auto heat Fill Mode.

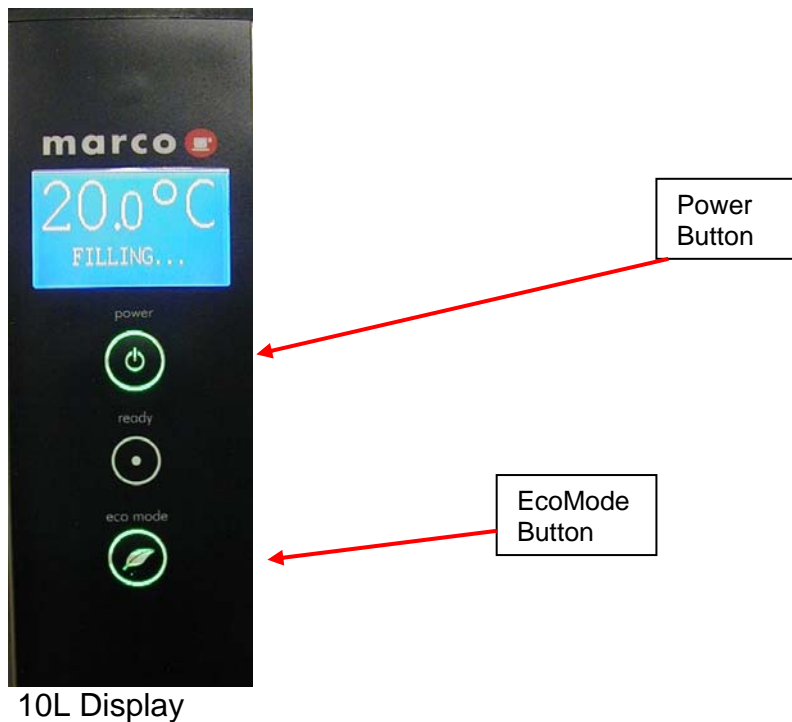

Figure 1: Machine User Interface

NOTE: Because the boiler is electronically controlled no priming is necessary. The element cannot switch on until a safe level of water is reached.

EcoSmart Features :

The EcoSmart Ecoboiler has many settable features which gives the operator great flexibility in choosing how the unit will operate. The following explains how the various features may be changed and their function.

There are 2 Menus in the EcoSmart Boiler

- 1 is to set the Boiler User settings and
- 1 is to set the Service/Maintenance parameters

HOW TO SETUP AN EcoSMART:

Smart Boiler (software 1.1) Display main screen description

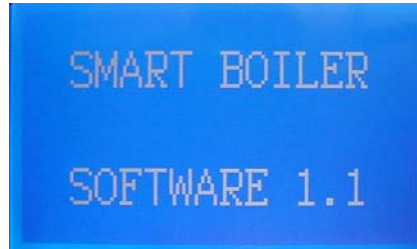

welcome screen

- The welcome screen will appear after any reset of the machine (e.g. power-up, changing setup values).
- It will show the actual software version.
- After few seconds the display will show the main screen:

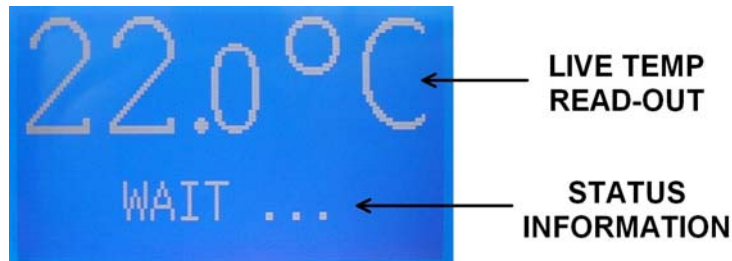

main screen

- Top part of the display always shows live read-out of the tank temperature (0.5°C accuracy).
- Bottom part shows current machine status.

Entering Setup Mode

- To enter setup mode press **power** and **eco** buttons on the front panel at the same time.
- The display will show "USER SETUP" message:







- Release the buttons now to enter the user setup mode.
- To enter advanced settings keep the buttons pressed until the display shows "SERVICE SETUP" message and release them.



- In both setup modes use front panel buttons to navigate the settings:
 - **power** button to scroll through the functions,
 - **eco** button to increase set value (press and hold for auto-repeat).

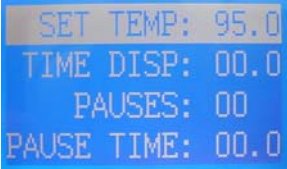
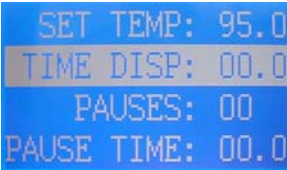





USER SET UP OPTIONS:

User Setup

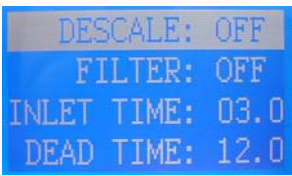
Screen view	Description	Default value
	Sets new tank temperature. Range: 60 – 99.5 °C Resolution: 0.5 °C	95.0
	Sets dispense time. Range: 0 – 99.9 seconds Resolution: 0.1 second For PUSH & HOLD mode set to 0 (default).	00.0
	Sets number of pauses during time dispense. Range: 0 – 20 If machine set as PUSH & HOLD then number of pauses has no impact on dispense.	00
	Sets pause time (same for each of the pauses). Range: 0 – 20.0 seconds Resolution: 0.1 second If machine set as PUSH & HOLD then time of pause has no impact on dispense.	00.0
	Press the eco button to save all the values and reset the machine.	-

SERVICE SETUP OPTIONS::

Service Setup

Screen view	Description	Default value
	<p>Sets and shows remaining weeks before de-scaling is needed (“DESCALE TANK” message on the screen).</p> <p>Setting it to OFF will disable the function.</p> <p>Range: 1 – 60 weeks</p>	OFF
	<p>Sets and shows remaining litres of water before filter change is needed (“CHANGE FILTER” message on the screen).</p> <p>Setting it to OFF will disable the function.</p> <p>Range: 100 – 9900 litres</p>	OFF
	<p>Sets the time for which the inlet opens every time the machine needs water. It minimises temperature fluctuations. The value should be picked to allow 0.5 - 1°C cooling after water intake and depends on the tank size and element power. This is a factory setting and should only be changed by trained personnel.</p> <p>Range: 0 – 20.0 seconds</p> <p>Resolution: 0.1 second</p>	3.0
	<p>Sets the time at which machine waits for the water too cool down after water intake. Measured from the beginning of the water intake. The value depends on tank size and element power. This is a factory setting and should only be changed by trained personnel.</p> <p>Range: 0 – 60.0 seconds</p> <p>Resolution: 0.5 second</p>	12.0
	<p>Sets the mode the machine works in:</p> <ul style="list-style-type: none"> • HEAT FILL (default – minimises temperature fluctuations), • CONT FILL (continuous fill – makes sure the tank is always full but temperature may vary), • COOL FILL (allows cooling but reduces tank size by using ECO mode), • MANUAL (manual filling). • See further explanations pg 8 	HEAT FILL
	<p>Press the eco button to save all the values and reset the machine.</p>	-

DISPLAY INFORMATION DESCRIPTIONS:

Status	Description
BOILER OFF	Machine off. Display backlight off but temperature read-out still working.
FILLING ...	Water level below low level probe. Machine is filling automatically. Status LED – 2 red blinks.
FILL THE TANK	Water level below low level probe. Machine has to be refilled manually (shown only in MANUAL mode). Status LED – 2 red blinks.
WAIT ...	Water is being heated. Dispense valve disabled.
BOILER READY	Water is up to the temperature and can be used. Note that this only means that the tank is heated and not that it is full. Status LED – green.
DISPENSE	Water is being dispensed. If machine is set to time dispense – there will also be a progress bar drawn underneath. Dispense can always be cancelled by clicking the dispense button again.
COOLING ...	Machine was set by the user to a lower temperature than the current tank temperature and is trying to cool down by taking in more cold water. This process may take between 20 seconds to a few minutes depending on tank size and temperature difference. Works only in COOL FILL mode.
DISPENSE WATER TO COOL THE TANK	Machine can not take more cold water to cool the tank because it is full. Water needs to be dispensed to allow room for more cold water to come in and finish cooling process.
DESCALE TANK	Descal timer elapsed. Time to descale the tank.
CHANGE FILTER	Litres output exceeds set value. Time to change the water filter.
CHECK LOW PROBE	Low water level probe broken (disconnected). Machine detects high level probe signal but can not detect low level one. Filling is disabled. Status LED – 1 red flash.
THERMISTOR S/C	Temperature sensor (thermistor) is short circuited. Dispense and heater disabled. Status LED – 3 red flashes.
ELEMENT FAILURE	Heating element is broken. Error is triggered when after 20 minutes of heating and not taking in water temperature in the tank fails to increase. Dispense is disabled. Status LED – 4 flashes.
THERMISTOR O/C	Temperature sensor (thermistor) is disconnected. Dispense and heater disabled. Status LED – 5 red flashes.
LOW PRESSURE	Incoming water pressure too low. The error will be reset after water supply restores. All boiler functions are active. Status LED – 6 flashes.
COMM ERROR	Display board lost communication with boiler PCB (can not receive serial data about temperature and probes). All actions cancelled.

Modes of Operations [Service setup setting 5]:

Modes of OPERATION - This boiler can operate in 3 different modes.
HEAT FILL – Standard operation the boiler will take in water until the temperature in the tank drops, the inlet will close and the heating element is activated. When the temperature reaches the set temperature the inlet will reopen to take in more water. This cycle will continue until the Tank is Full. This mode is used to ensure that the water temperature is controlled within set values.

CONTINUOUS MODE – In this mode the boiler will take in water and activate the element until the tank is full and the temperature has reached the set temperature. Typically used in high demand situations where the temperature stability is not primary concern.

COOL Mode – In this mode the temperature can be adjusted up or down [function 1.] while in operation. Depending on the water level in the tank selecting a lower temperature will cause either a message to “DISPENSE WATER TO COOL THE TANK” or will automatically take in cooler water to reduce the temperature to the new set temperature. In applications where selecting different temperatures frequently is required this Cool Mode is best selected.

Note in the Cool Mode this boiler will operate as a 5 ltr and not as a 10 ltr unit.

MANUAL FILL – if the boiler is not plumbed into a water supply the operator must select Manual Fill mode for best operation of the boiler. In this mode the water is added manually by the operator.

ECO Mode Operation:

Note In the COOL FILL mode [see Service setup setting 5] the ECO Mode is automatically selected.

- All ECO Boilers use high grade insulation and it is applied to give a significant energy usage improvement over a standard water boiler.
- The 10L ECO Boiler variants also incorporate a ½ tank ‘ECO mode’ function.
- To enable the ‘ECO Mode’ press the button located below the ‘Ready’ indicator so that the leaf symbol illuminates green.
- This mode saves energy by mimimising the energy wasted during machine down-time.
- NOTE: The ECO mode is most effective in installations where the machine has a regular ‘off’ period.
- To achieve the most benefit from the energy saving ‘ECO Mode’ on your ECO boiler unit (10L variants only), the following method should be employed:
 - Towards the end of the boilers operating period for a given day, switch the machine to ECO Mode. Whilst maintaing water at 96°C, the machine tank will slowly drop to half full, where it will remain.
 - At the end of the machines operating period it should the be turned ‘off’.
 - During the ‘off’ period as there is less water in the tank there will be less energy lost to the surrounding environment resulting in an energy saving.
- To disable simply press the ‘ECO Mode’ button again so that the leaf symbol is not illuminated

TROUBLESHOOTING:

The Ready/Status light signals various errors or problems. A cycle of red flashes indicates an error. The number of flashes in a cycle corresponds to the symptom in the table below:

Status/Diagnostic light guide:

No of flashes	Symptom	Action required
2	Water level below elements. Normal when machine first fills.	Check water pressure , if this is OK then call service agent.
3	Temperature sensor failure (o/c)	Call service agent
4	Water not heating	Call service agent
5	Temperature sensor failure (s/c)	Call service agent
6	Machine not filling	Check water pressure, if OK then call service agent.

MAINTENANCE:

This machine has been designed to give many years of trouble free service. The only regular maintenance required is occasional de-scaling.

Descaling Procedure:

- Isolate machine from power supply.
- Isolate machine from water supply.
- ALLOW TO COOL COMPLETELY!
- Drain water from machine.
- Remove all lids.
- Remove as much scale as possible by hand, paying particular attention to level probes (White plastic with steel tab). Be very careful not to damage any attachments.
- Use ScaleKleen, Marco part No. 8000270 or similar. Follow instructions carefully.
- Thoroughly clean and flush the machine before re-use.
- Follow installation and first time operation instructions.

CLEANING:

The exterior of these machines may be cleaned with a damp cloth and a light detergent. Do not use abrasive cloths or creams, as this will spoil the finish of the machine. Do not use a water jet or spray.

NB: Beware of accidentally operating the draw off tap or push button when cleaning the front of the machine.

LIMESCALE:

In common with all water boiler manufacturers, service calls resulting from limescale are not covered by warranty. Fitting a scale reducer is recommended, especially in hard water areas. This can reduce the build-up of scale but may not stop it altogether. The frequency that descaling is required depends on the local water supply; hard water areas need more attention. Descaling of the machine should ideally be carried out by qualified service personnel.

ACCESS TO INTERNAL COMPONENTS:

Removal

Any maintenance work on any EcoBoiler product should **ONLY** be conducted by a trained service engineer.

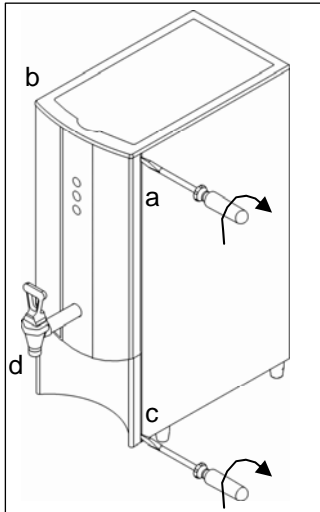

1. Disconnect the machine from the electrical supply.
2. Allow to cool sufficiently.
3. The metal upper and lower front panels are clipped to the main body.
4. Insert flat headed screwdriver at the four locations indicated on the picture and rotate to separate the panels.
Note:- There is no need to 'lever' the screwdriver - a small rotation is all that is required.

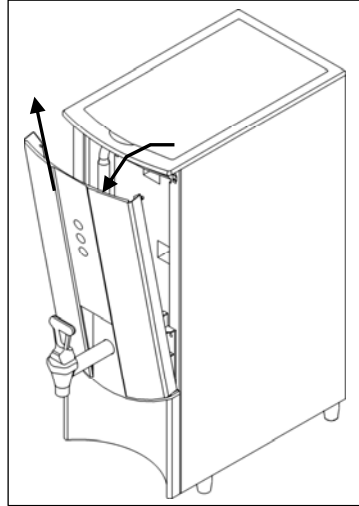

5. To remove the upper front panel, rotate the top of the panel forward and lift.

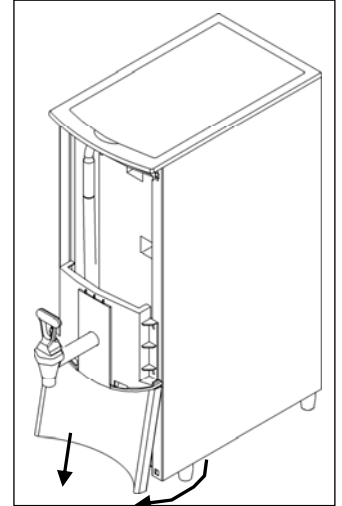

6. To remove the lower front panel, rotate the bottom of the panel forwards and slide downwards.

Model show EcoBoiler PB10 for illustrations purposes

Assembly

To re-attach the front panels, complete the removal actions in steps 5 & 6 in reverse order. Ensure that the panel clips are securely fastened.

Intentionally Blank

Intentionally Blank