

Falk™ TRUE HOLD® Low Speed Backstops

The Greater the Torque, the Tighter the Hold (English–Inch/Metric)



Falk™ TRUE HOLD® Low Speed Backstops Never Let Safety Slip

Anytime you're moving materials up grade, you have the potential for trouble. Should the electric power fail, a motor fail or someone trip the emergency cable, the results can be disastrous. . . for employees and for equipment. That's why operations the world over, rely on Falk™ TRUE HOLD® Backstops and their instant-response, no-slip mechanism to help put a stop to trouble before it can start. Size-for-size TRUE HOLD Backstops provide more system holding power than any other backstop. Plus, Long-life designs and our ability to engineer and manufacture complete, integrated drive packages, assure that you get the ideal system for your needs, whether it's a single, tandem, or multiple backstop configuration. Now, that's confidence. . . that's TRUE HOLD.



Benefits/Features Falk TRUE HOLD - NRT Style

Long Lasting

Our unique double lip, dual seal system assures long life, includes splash oil circulation, factory packed grease cavity, contamination proof oil sight glass, and Airmax® breather.

Rexnord Drives System Expertise

Assistance with proper selection for your specific application whether single, tandem, or multiple drives.

For virtually any application where materials need to be moved up steep grades, including inclined conveyors, high angle conveyors, bucket elevators used in mining, grain, power generation, cement and aggregates. TRUE HOLD NRT backstops with torque rating to 747,000 ft-lb (1,012,185 Nm).

Increased Life

Their oversized, heavy duty cylindrical rollers have a wide contact area and the rolling action minimizes wear and increases performance, life, and reliability.

No Slip

The instant response, fail safe roller/ramp stopping mechanism prevents reverse rotation and eliminates the potential for slippage protecting man, machine, and your entire investment.

Available

Stock bore sizes available in 1 week or less with our premium breakdown service. (See Page 4.)

The Falk NRT backstops are furnished with the best available lubrication and lubrication sealing system in the industry. Two double-lip seals on both sides of the backstop assure positive lube retention. The external seal grease purge feature combined with the Airmax breather prevent contamination of the generous oil supply from particulate matter and from moisture laden air.



Factory Warranty*— We're so confident in the performance and reliability of these backstops that we're backing the fully featured NRT series with the best standard warranty in the business. Our full, 3-year Heavy-Duty Warranty provides "shaft-to-shaft" protection on all Falk components – including bearings and seals (warranty extends for years from date of shipment). It's an industry first. . . and one more powerful reason why Rexnord is your ultimate bottom-line value.

★ NRT series are provided with one year warranty.



Our Falk TRUE HOLD Backstop line consists of two configurations to suit your backstopping needs!

Falk TRUE HOLD **NRT** utilizes the field-proven, roller-ramp principle.

Where Used —

High Torques, Large Bores, Fully Featured

How it Works —

Backstopping: The inner cam, which is keyed to the shaft, is stopped by a spring activated wedging action, forcing rollers into an angular opening between the inner cam ramps and outer race.

Over-Running: While in the over-running mode, the robust, precision ground cylindrical rollers are centrifugally pushed against the stationary outer race of the NRT backstop. This centrifugal force causes the rollers to roll (versus skid or slide) against the forged steel, outer race extending the service life.

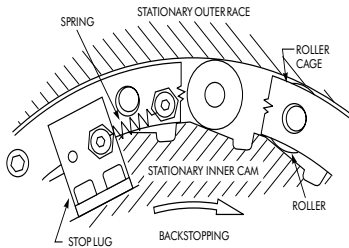

Falk TRUE HOLD **NRTH** utilizes a sprag design for preventing reverse rotation.

Where Used —

Lower Torques, Smaller Bores, Higher Speeds

How it Works —

Backstopping: The inner race, which is keyed to the shaft, utilizes spring positioning sprags into a wedged position between the inner and outer race, preventing the load from rotating backwards.

Over-Running: Sprags are held in place by a cage providing equal separation to ensure no binding occurs while the backstop is in an over-running condition.

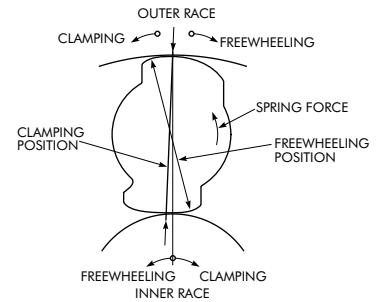

The graph below illustrates the maximum speed and torque for both the NRT and NRTH style backstops.

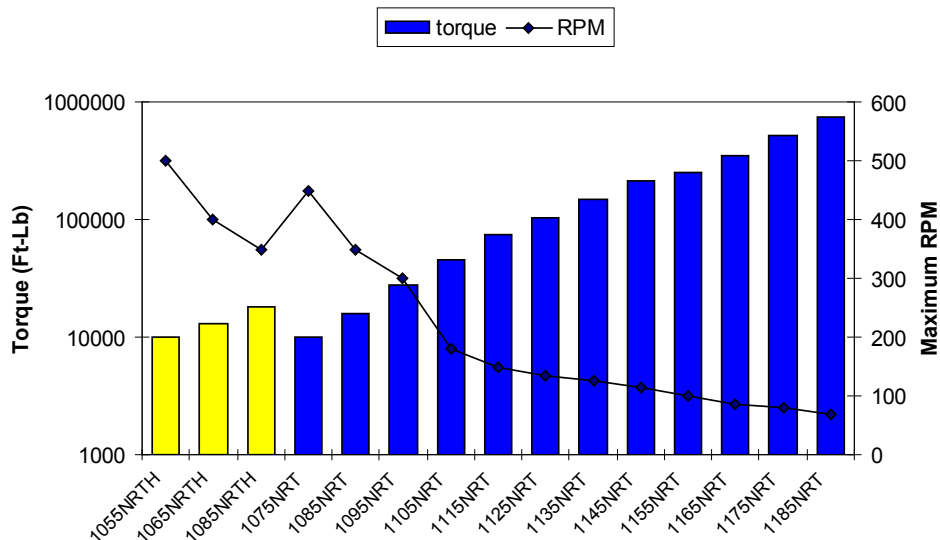

How to Order

The following information along with selection information from Pages 6 thru 8 is required to order a backstop:

- Type of torque used to select (Motor, Brake, or Lift)
- Torque arm mounting position (see Pages 10-13)
- Overrunning rotation
- Number of retaining collars

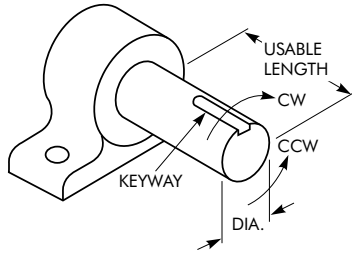

System Characteristics — Supply any information about the system to which the Falk NRT or NRTH backstop is being applied that would affect the selection of the backstop (or holdback); for example, “Are there any torque limiting devices with the motors? Is material feed restricted in any way to prevent overload of the material handling system? Will the system produce overloads that could exceed the motor’s stall torque capacity?”

NRT / NRTH Backstop Order Information Required (or previous Falk M.O. Number)

	Size
	Quantity
	Backstop Rotation (CW or CCW)
	Shaft Diameter and Tolerance (mm or inches)
	Available Shaft Length (mm or inches)
	Kwy _____ x _____ (mm or inches)
	Torque Arm Position in Degrees (See illustrations on Pages 10 - 13)
	If Non-Std Torque Arm, advise 'N' dim. Pages 12 & 13 (inches or mm)
	Power (Indicate kW or Hp, Lift, Demand, or Motor)
	RPM of Shaft that Backstop is Mounted upon
	% Motor Stall Torque or Max Overload Torque
	% Stall Torque
	Number of Retaining Collars

NOTE: Provide information above, plus a drive layout schematic for multiple pulley applications.

Stock Bore Size

NRT SIZE	Inch	Metric
1075	3.4375	100
1075	3.9375	
1085	4.4375	130
1085	4.9375	
1095	4.9375	150
1095	5.4375	
1105	5.9375	200
1105	6.9375	
1115	6.9375	220
1115	7.4375	
1115	7.9375	
1115	8.000	
1115	8.4375	
1125	8.5000	240
1125	8.9375	
1125	9.0000	
1135	10.5000	260
1145		300
1155		350

The bore sizes listed above can ship from stock in one week.

Metric Backstops — supplied with E7 bore and D10 keyway assuming m6 shaft diameter and h9 keyway (ISO tolerance specification).

Inch Backstops — supplied with H7 bore assuming h6 shaft (ANSI tolerance specification). Backstop key and keyway tolerance per FDN 430-152 assuming shaft keyway per ANSI B17.1.

Selection Guide 561-110, February 2009

Table of Contents

Comparison of NRT & NRTH	3
Stock Bore Sizes.	4
How to Order	4
Basic Information.	5
How to Select Falk NRT & NRTH Backstops	6 – 7
Common Drive Arrangements.	8
Load Sharing.	9
Dimensions	10 – 13
Backstop Operation	14 – 15
Service Parts	16
Engineering Recommendations	17 – 21
Competitive Interchangeability Chart	22-23
Backstop Selection Procedure Definitions.	24
NRT Test Protocol.	25
Typical Applications	26
Accessories	27

Basic Information

Safety Notes

Install and operate Rexnord products in conformance with applicable local and national safety codes and per Rexnord installation manuals which are available upon request. Suitable guards for rotating members may be purchased from Rexnord as optional accessories. Refer to your local Rexnord District Office for complete details.

WARNING: *Lock out power source and remove all external loads from gear drive before servicing drive or accessories. Locking out the power source and removing the load will reduce the possibility of an unexpected motion or reaction in the system.*

People Conveying Equipment — Selection of Rexnord products for applications whose primary purpose is the transportation of people is not approved. This includes such applications as freight or passenger elevators, escalators, man lifts, work lift platforms, and ski tows and ski lifts.

If the primary purpose of the application is material conveyance and occasionally people are transported, the Rexnord warranty may remain in effect provided the design load conditions are not exceeded and certification to the appropriate safety codes and load conditions has been obtained by the system designer or end user from the appropriate enforcement authorities.

Lubricants — Refer to Manuals 568-101, 568-102, 568-104, and 568-110 for a listing of transmission fluids, oils, and greases that meet Rexnord specifications.

Stored or Inactive Backstops — Backstops, Sizes 1075-1185NRT are shipped without lubricant, with one ounce of Motorstor* vapor phase rust inhibitor in the backstop that protects the internal parts against rust for a period of six months.

If the backstop (Sizes 1075-1185) is to be stored or inactive for more than six months, add lubricant and Motorstor* as recommended in the service manual for every additional six month period. Indoor storage or a suitable covering is recommended.

Backstop, Size 1045NRTH, Style B, is shipped with grease. If stored, once every two months, inner race should be rotated by hand to lubricate rotating elements.

Backstops, Sizes 1055NRTH, 1065NRTH, and 1085NRTH, Style B, are shipped from the factory filled to the proper level with oil. If stored, rotate inner hub every two months to lubricate rotating elements.

Backstops, Sizes 1055 and 1065NRTH, Style C, are prelubricated and require no further maintenance of the working mechanism.

If the backstop is to remain inoperative for extended periods of time, remove the load before shutting down. Refer to service manual for complete instructions.

* Product of the Daubert Chemical Company, Chicago, IL

Copyright 1979, 2009, Rexnord Industries, LLC. All Rights Reserved. Litho in U.S.A. Airmax, Rexnord, and TRUE HOLD are registered trademarks. Falk and Magnum Seal are trademarks of Rexnord. Viton is a registered trademark of the DuPont Co. The contents of this selection guide are subject to change without notice or obligation. Information contained herein should be confirmed before placing orders.

How to Select Falk TRUE HOLD NRT & NRTH Backstops — Imperial

(Refer to Page 24 for explanation of terms and Page 4 for How to Order)

1. Determine Drive Arrangements from Page 8.

2. Determine System Torque.

Fig. 1 — Single motor, Single backstop arrangements.

Fig. 2 — Tandem motor, single backstop arrangements.

Fig. 3 — Tandem motor, tandem backstop arrangements.

Figs. 4 and 5 — Refer these arrangements to Factory for selection.

Combine the horsepower from both motors for Fig. 2 and Fig. 3.

$$\text{System Torque} = \frac{5250 \text{ (MHP or BHP or LHP)}}{\text{rpm (rev/min)}}$$

MHP — Motor Nameplate HP

BHP — Brake HP (Calculated Load). Use only if more than 75% of motor rating.

LHP * — Lift HP (Calculated Power to Lift the Load Vertically. Use only if more than 75% of motor rating.)

* LHP can be calculated as follows:

$$\frac{\text{Short Tons Per Hour (TPH)} \times \text{Lift in Feet}}{990}$$

3. Determine Required Backstop Torque.

* Required Backstop Torque =

$$\frac{\text{System Torque} \times \text{Motor Maximum Torque (Stall or Breakdown Torque) \blacktriangle}}{150\%}$$

* For Figure 3 — Tandem motor, tandem backstop arrangements, select each backstop to hold 60% of the total Required Backstop Torque.

▲ Use whichever is greater.

- From Pages 10 thru 12, select backstop with a torque rating equal to or greater than the required torque rating determined above.
- Check the maximum bore, Pages 10 thru 12. If a larger bore is required, select the next larger size or turn the headshaft down.
- Check the maximum overrunning speed from Pages 10 thru 12. Refer to the Factory for higher speeds.
- Check backstop reaction force at torque arm stirrup, Table 4, Page 20.
- Backstop and torque arm dimensions are listed on Pages 10 thru 12; allow space for installation.
- Only use keys furnished by the Factory.

If the backstop is mounted on the double ended extension of the drive shaft, check shaft stresses and use dual path (safety lock) couplings or a minimum 2.0 service factor on the combined horsepower for the coupling on the NRT side.

Indexing requirements must be referred to the Factory for selection.

4. NRTH Style B and NRTH Style C backstops are rated for more than 1,000,000 cycles of backstopping.

NRT Backstops are rated for 100,000 backstopping cycles.

If your application needs more than 100,000 load cycles, refer application to the Factory for selection.

Engineered Selection Method for Inclined Conveyors — It is possible to fine tune the selection and possibly consider the selection of a smaller size backstop, if detailed loading and conveyor profile information is furnished.

The following data is necessary:

- Power to lift the load (vertical)
- Power to move empty belt (friction)
- Power to move loaded belt horizontally (friction)

We can calculate these values if the following data is provided:

- Conveyor length (L) — feet
- Belt speed — fpm
- Short tons per hour — tph
- Total lift (H) — feet
- Belt width — inches
- Material weight — lb/ft
- Pulley rpm (rev/min) or diameter — feet

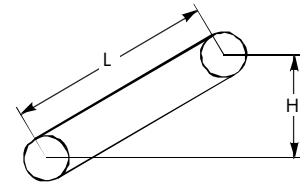

Selection Example

The selection example, below, show the benefits gained from obtaining the required information to select by brake or lift torque vs motor torque.

Figure 1 — Single motor, single backstop arrangements

Figure 2 — Tandem motor, single backstop arrangements — Select backstop to hold the **entire** system torque.

Figure 1 — Single motor, single backstop arrangements.

Steep Slope Conveyor	
200 Motor HP	
180 Brake HP	
150 Lift HP	
200% Stall	
68 rpm (rev/min)	
4.9375 Dia	
Motor HP and Stall % Known	
$\frac{200 \text{ MHP} \times 5250}{68 \text{ RPM}} \times \frac{200\%}{150\%} =$	
20,588 lb-ft Motor Torque	
Size 1095 NRT	
Brake HP Known	
$\frac{180 \text{ BHP} \times 5250}{68 \text{ RPM}} \times \frac{200\%}{150\%} =$	
18,529 lb-ft Brake Torque	
Size 1095 NRT	
Lift HP Known	
$\frac{150 \text{ LHP} \times 5250}{68 \text{ RPM}} \times \frac{200\%}{150\%} =$	
15,441 lb-ft Lift Torque	
Size 1085 NRT	

How to Select Falk TRUE HOLD NRT & NRTH Backstops — Metric

(Refer to Page 24 for explanation of terms and Page 4 for How to Order)

1. Determine Drive Arrangements from Page 8.

2. Determine System Torque.

- Fig. 1 — Single motor, Single backstop arrangements.
- Fig. 2 — Tandem motor, single backstop arrangements.
- Fig. 3 — Tandem motor, tandem backstop arrangements.
- Figs. 4 and 5 — Refer these arrangements to Factory for selection.

Combine the kilowatts from both motors for Fig. 2 and Fig. 3.

$$\text{System Torque} = \frac{9550 \text{ MkW or BkW or LkW}}{\text{rpm (rev/min)}}$$

MkW — Motor(s) Nameplate kW

BkW — Brake kW (Calculated Load). Use only if more than 75% of motor rating.

LkW * — Lift kW (Calculated Power to Lift the Load Vertically. Use only if more than 75% of motor rating.)

* LkW can be calculated as follows:

$$\frac{\text{Metric Tons per Hour (TPH)} \times \text{Lift in Meters}}{5150}$$

3. Determine Required Backstop Torque.

* Required Backstop Torque =

$$\frac{\text{System Torque} \times \text{Motor Maximum Torque (Stall or Breakdown Torque)} \blacktriangle}{150\%}$$

* For Figure 3 — Tandem motor, tandem backstop arrangements, select each backstop to hold 60% of the total Required Backstop Torque.

▲ Use whichever is greater.

- A. From Page 10,11 or 13 select backstop with a torque rating equal to or greater than the required torque rating determined above.
- B. Check the maximum bore, Page 10,11 or 13. If a larger bore is required, select the next larger size or turn the headshaft down.
- C. Check the maximum overrunning speed from Page 10,11 or 13. Refer to the Factory for higher speeds.
- D. Check backstop reaction force at torque arm stirrup, Table 4, Page 20.
- E. Backstop and torque arm dimensions are listed on Page 10,11 or 13; allow space for installation.
- F. Only use keys furnished by the Factory.

If the backstop is mounted on the double ended extension of the drive shaft, check shaft stresses and use dual path (safety lock) couplings or a minimum 2.0 service factor on the combined horsepower for the coupling on the NRT side.

Indexing requirements must be referred to the Factory for selection.

4. NRTH Style B and NRTH Style C backstops are rated for more than 1,000,000 cycles of backstopping.

NRT Backstops are rated for 100,000 backstopping cycles. If your application needs more than 100,000 load cycles, refer application to the Factory for selection.

Engineered Selection Method for Inclined Conveyors — It is possible to fine tune the selection and possibly consider the selection of a smaller size backstop, if detailed loading and conveyor profile information is furnished.

The following data is necessary:

- Power to lift the load (vertical)
- Power to move empty belt (friction)
- Power to move loaded belt horizontally (friction)

We can calculate these values if the following data is provided:

- Conveyor length (L) — meters
- Belt speed — (mpm)
- Metric tons per hour — TPH
- Total lift (H) — meters
- Belt width — millimeters
- Material weight — Kg/M
- Pulley rpm (rev/min) or diameter — meters

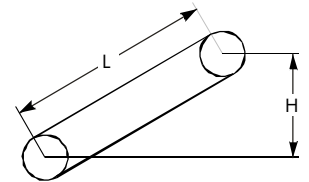

Selection Example

The selection examples below show the benefits gained from obtaining the required information to select by brake or lift torque vs motor torque.

Steep Slope Conveyor	
150 Motor kW	
135 Brake kW	
115 Lift kW	
200% Stall	
68 rpm (rev/min)	
125 mm Dia	
Motor kW and Stall % Known	
$\frac{150 \text{ MkW} \times 9550}{68 \text{ RPM}} \times \frac{200\%}{150\%} =$	
28,088 Nm Motor Torque	
Size 1095 NRT	
Brake kW Known	
$\frac{135 \text{ BkW} \times 9550}{68 \text{ RPM}} \times \frac{200\%}{150\%} =$	
25,279 Nm Brake Torque	
Size 1095 NRT	
Lift kW Known	
$\frac{115 \text{ LkW} \times 9550}{68 \text{ RPM}} \times \frac{200\%}{150\%} =$	
21,534 Nm Lift Torque	
Size 1085 NRT	

Common Drive Arrangements

Figure 1 — Single motor, single backstop arrangements

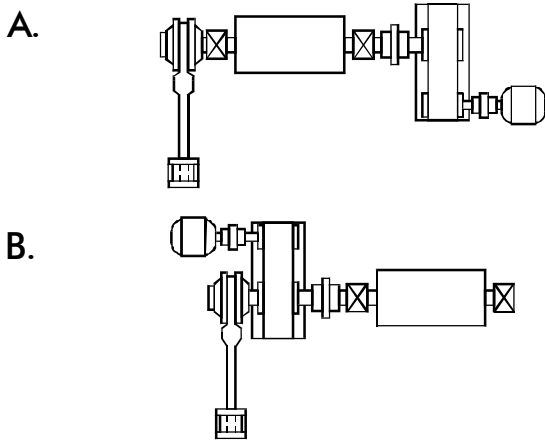

Figure 2 — Tandem motor, single backstop arrangements – Select backstop to hold the *entire* system torque.

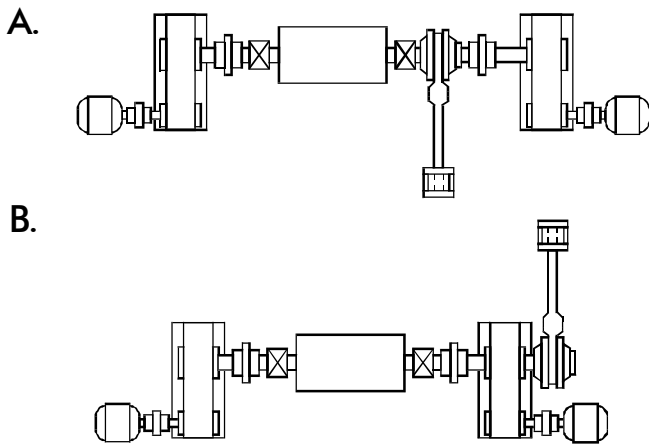
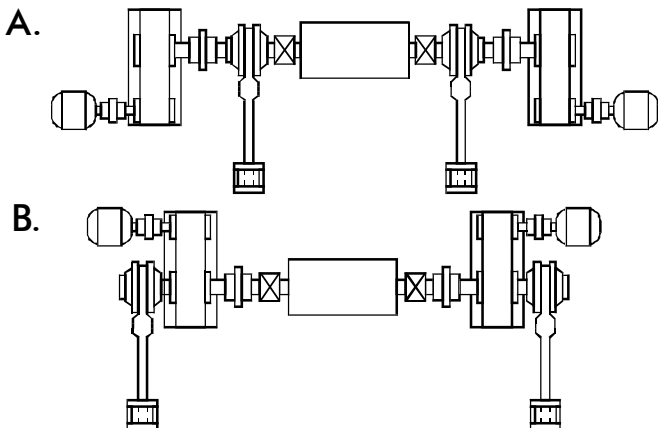

Figure 3 — Tandem motor, tandem backstop, single pulley arrangements – Select each backstop to hold 60% of total system backstop torque.



For drive arrangements shown in Figures 4 & 5, Engineered Selections, Indexing applications, Vertical applications or for drive arrangements not shown, refer to Factory for selection.

We will select a backstop for you if you furnish the following information:

- Drive arrangement
- Motor nameplate hp (kW)
- Motor maximum torque as % of nameplate
- Headshaft rpm (rev/min), diameter, diameter tolerance, length and key dimensions
- Duty cycle

If available, the following information when furnished may make it possible to select a smaller size backstop:

- Brake (BkW)
- Lift hp (LkW)

Figure 4 — Tandem motor, tandem backstop, dual pulley arrangement – Refer to the Factory for selection.

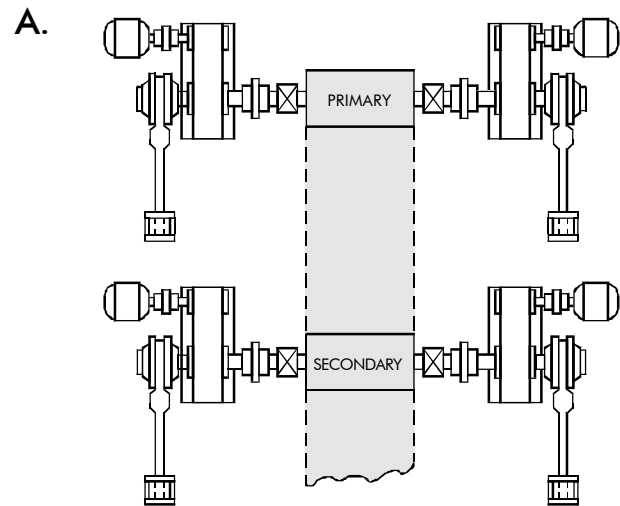
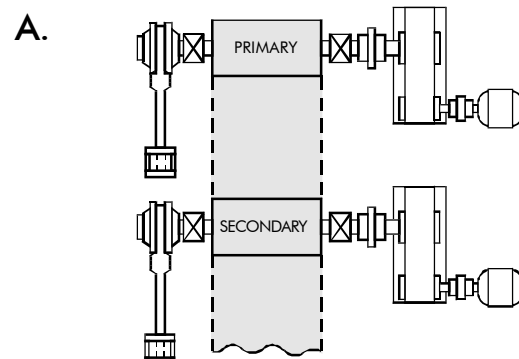

Figure 5 — Dual motor, dual backstop, dual pulley arrangement – Refer to the Factory for selection.



Load Sharing

HYDRAULIC LOAD SHARING SYSTEMS FOR LOW SPEED BACKSTOPS ON HIGH CAPACITY MATERIAL HANDLING SYSTEMS.

Hydraulic Load Sharing Systems have been used successfully on high capacity, multi-drive material handling systems to assure a balanced load on each backstop. A simple hydraulic power unit (with accumulator, pressure switch, and pressure gauges) maintains system pressure in a pre-determined range to meet the backstopping requirements of the material handling system.

Typical installations are dual pulley/quad drive installations employing motors of 1000 HP (750 kW) or larger. The Hydraulic Load Sharing System not only balances the load on each backstop, it also extends the capability of the NRT Backstop range by eliminating the need to assume 'unbalanced load distribution' in the selection process due to variances in system backlash and component stiffness.

The design of the Hydraulic Load Sharing Backstopping Systems utilizes NRTs of equal capacity mounted on pulleys of equal diameter. Hydraulic cylinders of equal cylinder area are placed at equal distances from the centerline of each pulley under their respective NRT torque arms.

A hydraulic charge pump delivers system oil pressure to hydraulic piping that is interconnected. The oil pressure in the interconnected hydraulic piping is equal so the pistons are subjected to equal pressure. Equal pressure applied to hydraulic cylinders with equal cylinder area, creates an equal amount of force to each torque arm. Equal force on the torque arms at equal distances from the centerline of the pulleys produces equal backstopping torque at each pulley. Therefore, you achieve balanced loading. Rexnord Geared Products Group also has the experience and expertise to select and apply Gear Drive Systems with mechanical load sharing backstops. Contact Rexnord for assistance.

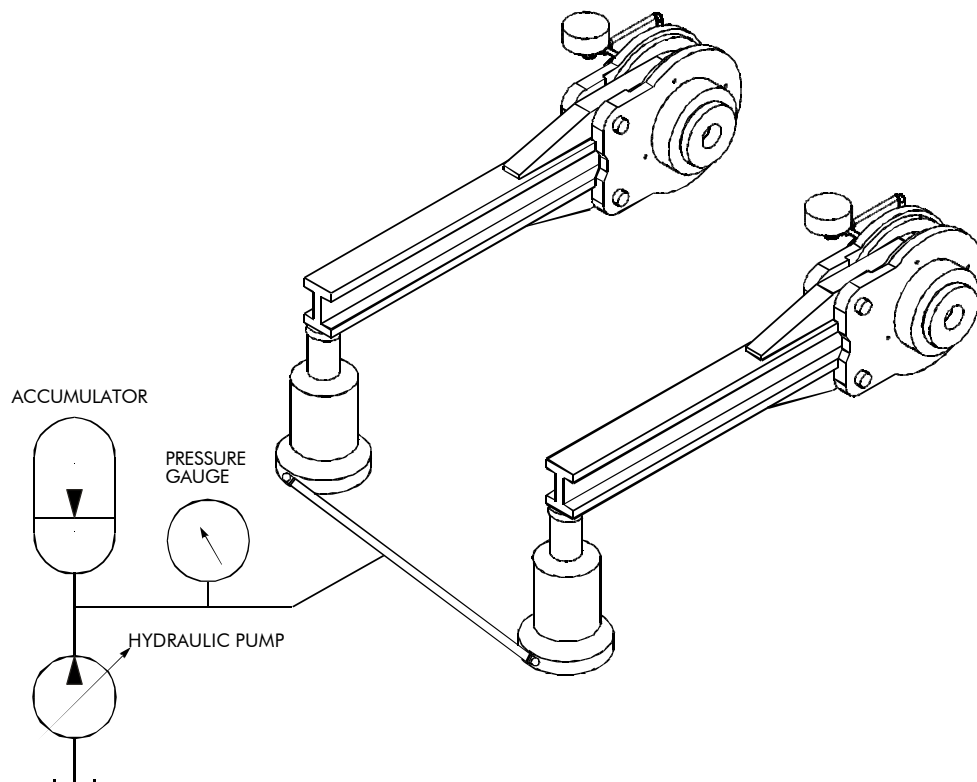

Type NRTH – Style B (L.S. Applications) – Dimensions — Inches & Millimeters

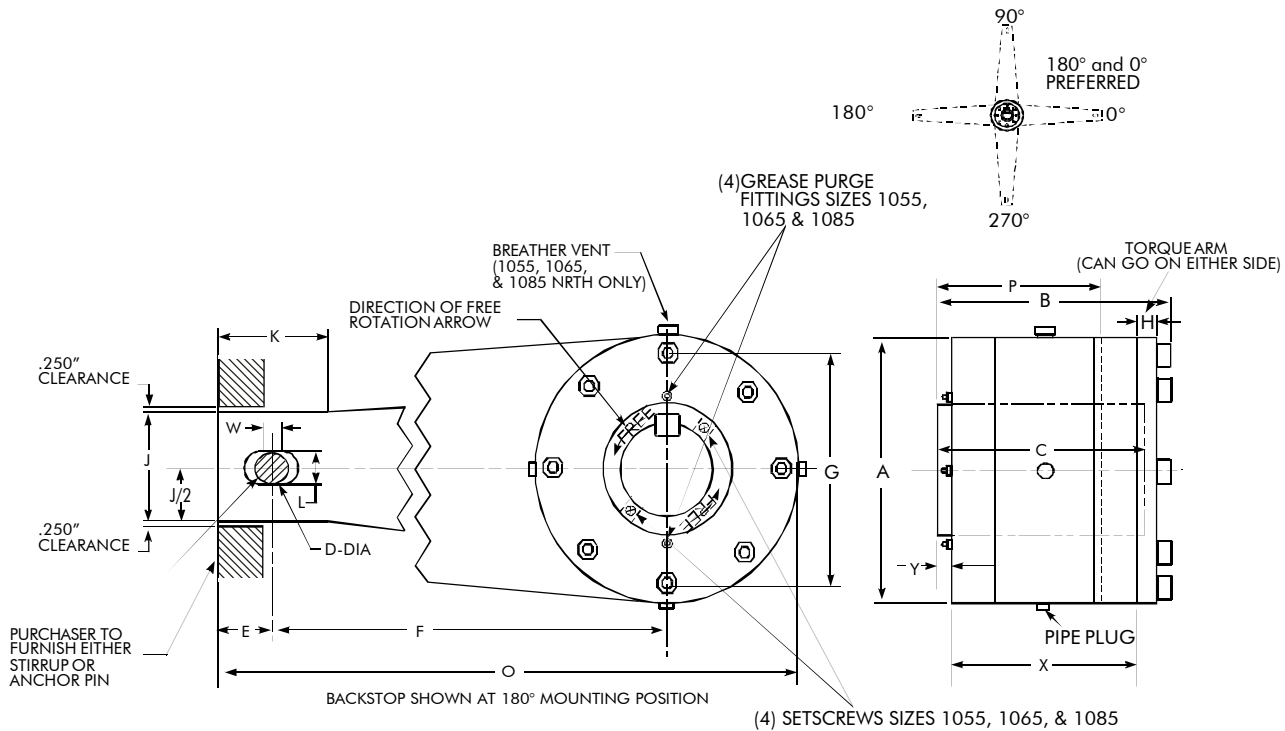

Dimensions — Inches

Backstop Size	Torque Rating lb-ft	Max rpm	Bore ★		A	B	C■	D◆	E	F	G	H	J	K	L	W	X	Y	O	P●	Torque Arm Fasteners †	Wt ‡ lb
			Min	Max																		
1045*	2,100	1,800	1.75	2.50	6.50	4.19	3.50	0.656	1.25	7.00	5.75	0.375	2.50	1.50	0.78	0.72	3.38	0.06	11.50	2.62	(8) 3/8-24 X 1.0" LG	29
1055*	10,000	500	1.75	3.75	9.75	8.14	7.50	1.125	2.00	36.00	8.50	0.625	4.00	4.00	1.25	0.63	6.53	0.48	42.88	5.50	(8) 1/2-20 X 2.0" LG	157
1065*	13,000	400	2.50	4.50	10.50	8.64	8.00	1.125	2.00	36.00	9.25	0.625	4.00	4.00	1.25	0.63	7.03	0.48	43.25	5.88	(8) 1/2-20 X 2.0" LG	190
1085*	18,000	350	3.94	5.44	12.00	8.52	7.63	1.250	3.00	51.00	10.00	0.750	6.00	10.00	N/A	N/A	6.63	0.50	60.00	5.88	(10) 5/8-18 X 1.75" LG	260

Dimensions — Millimeters

Backstop Size	Torque Rating Nm	Max rpm	Bore ★		A	B	C■	D◆	E	F	G	H	J	K	L	W	X	Y	O	P●	Torque Arm Fasteners †	Wt ‡ kg
			Min	Max																		
1045*	2,847	1,800	44	64	165	106	89	17	32	178	146	10	64	38	20	18	86	2	292	67	(8) 3/8-24 X 1.0" LG	13.2
1055*	13,557	500	44	95	248	207	191	29	51	914	216	16	102	102	32	16	166	12	1089	140	(8) 1/2-20 X 2.0" LG	71.2
1065*	17,625	400	64	114	267	219	203	29	51	914	235	16	102	102	32	16	179	12	1099	149	(8) 1/2-20 X 2.0" LG	86.1
1085*	24,403	350	100	140	305	216	194	32	76	1295	254	19	152	254	N/A	N/A	168	13	1524	149	(10) 5/8-18 X 1.75" LG	118.2

★ Key is furnished by the Factory.

† Fasteners are Hex Socket Head Cap Screws, Grade 8

‡ Weight shown is for backstop with minimum bore.

● Minimum shaft engagement for backstop support.

■ Length through hub.

◆ 1085NRTH – Hole for lifting purposes only.

* 1045NRTH backstops are shipped with lubriplate AERO NLGI#1/Grease Lubricant. 1045NRTH backstops require a keeper plate or retaining collars for axial retention.

♣ 1055, 1065, and 1085NRTH backstops are shipped with lubricant (DEXRON). 1055, 1065, and 1085NRTH backstops are furnished with four(4) radial holes and setscrews in the inner cam for axial retention on the shaft.

Mounting Positions — The backstop rotational axis must be horizontal within 5°.

The backstop and torque arm may be mounted at any desired angle. Horizontal or near horizontal mounting of the torque arm provides maximum bearing life.

Purchaser — The purchaser is responsible for assembling the backstop, air vent, and torque arm. A 125 micro inch (3.2 micro meters), or finer, shaft finish is recommended.

NOTE: Electronic drawings are available from our Website: http://pt.rexnord.com/customer_support/drawings

Type NRTH – Style C (H.S. Applications) – Dimensions — Inches & Millimeters

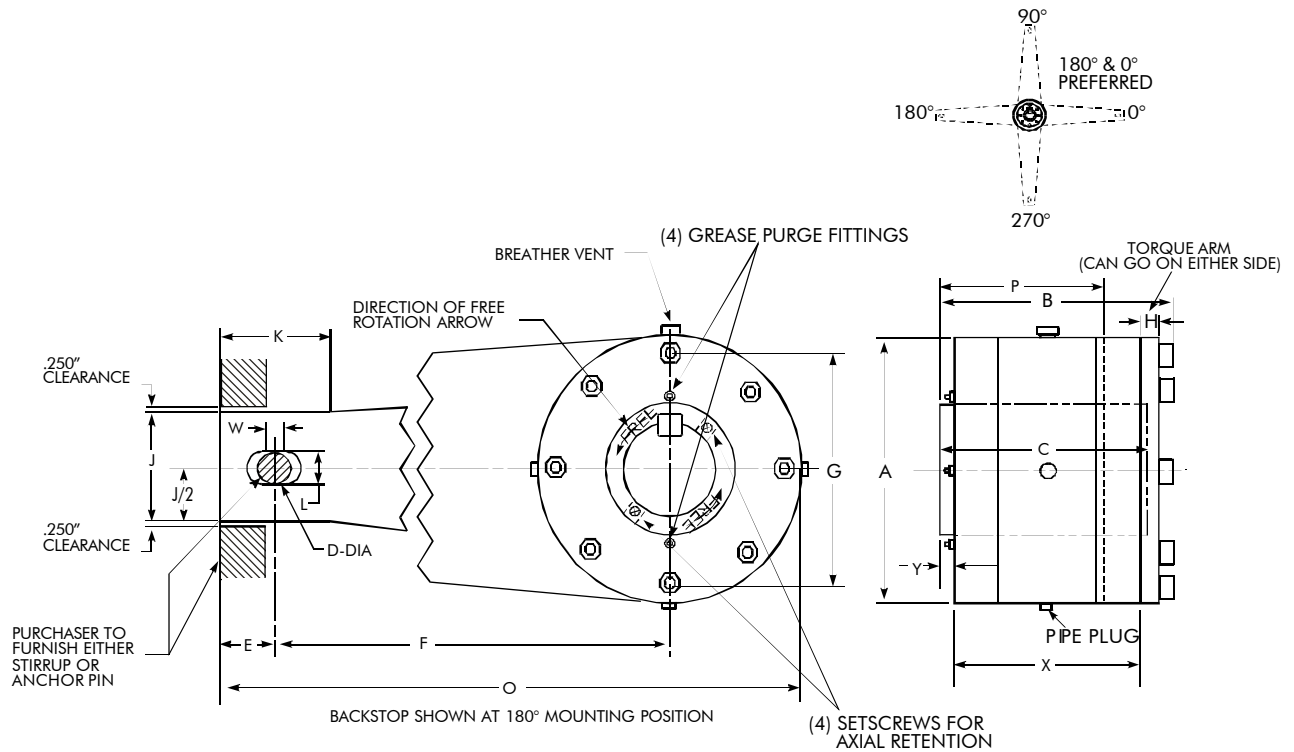

Dimensions — Inches

Backstop Size	Torque lb-ft	Speed Range		Bore *		A	B	C	D	E	F	G	H	J	K	L	W	X	Y	O	P	Torque Arm Fasteners †	Wt ‡ lb
		Min	Max	Min	Max																		
1055*	4,400	320	2,100	1.75	3.75	9.75	8.14	7.50	1.125	2.00	36.00	8.50	0.625	4.00	4.00	1.25	0.63	6.53	0.48	42.88	5.50	(8) 1/2-20 X 2.0" LG	157
1065*	8,400	250	1,800	2.50	4.50	10.50	8.64	8.00	1.125	2.00	36.00	9.25	0.625	4.00	4.00	1.25	0.63	7.03	0.48	43.25	5.88	(8) 1/2-20 X 2.0" LG	190

Dimensions — Millimeters

Backstop Size	Torque Nm	Speed Range		Bore *		A	B	C	D	E	F	G	H	J	K	L	W	X	Y	O	P	Torque Arm Fasteners †	Wt ‡ kg
		Min	Max	Min	Max																		
1055*	5,965	320	2,100	44	98	248	207	191	29	51	914	216	16	102	102	32	16	166	12	1,089	140	(8) 1/2-20 X 2.0" LG	71.2
1065*	11,388	250	1,800	64	115	267	219	203	29	51	914	235	16	102	102	32	16	179	12	1,099	149	(8) 1/2-20 X 2.0" LG	86.1

* Key is furnished by the Factory.

† Fasteners are Hex Socket Head Cap Screws, Grade 8.

‡ Weight shown is for backstop with minimum bore.

● Minimum shaft engagement for backstop support.

■ Length through hub.

* Style C size 1055 and 1065NRTH backstops are shipped permanently lubricated, no additional lubrication or re-lubrication is required. Grease fittings for optional purging of seals are provided.

Mounting Positions — The backstop rotational axis must be horizontal within 5°.

The backstop and torque arm may be mounted at any desired angle. Horizontal or near horizontal mounting of the torque arm provides maximum bearing life.

Purchaser — The purchaser is responsible for assembling the backstop, air vent, and torque arm. A 125 micro inch (3.2 micro meters), or finer, shaft finish is recommended.

NOTE: Electronic drawings are available from our Website: http://pt.rexnord.com/customer_support/drawings

Type NRT Dimensions — Inches

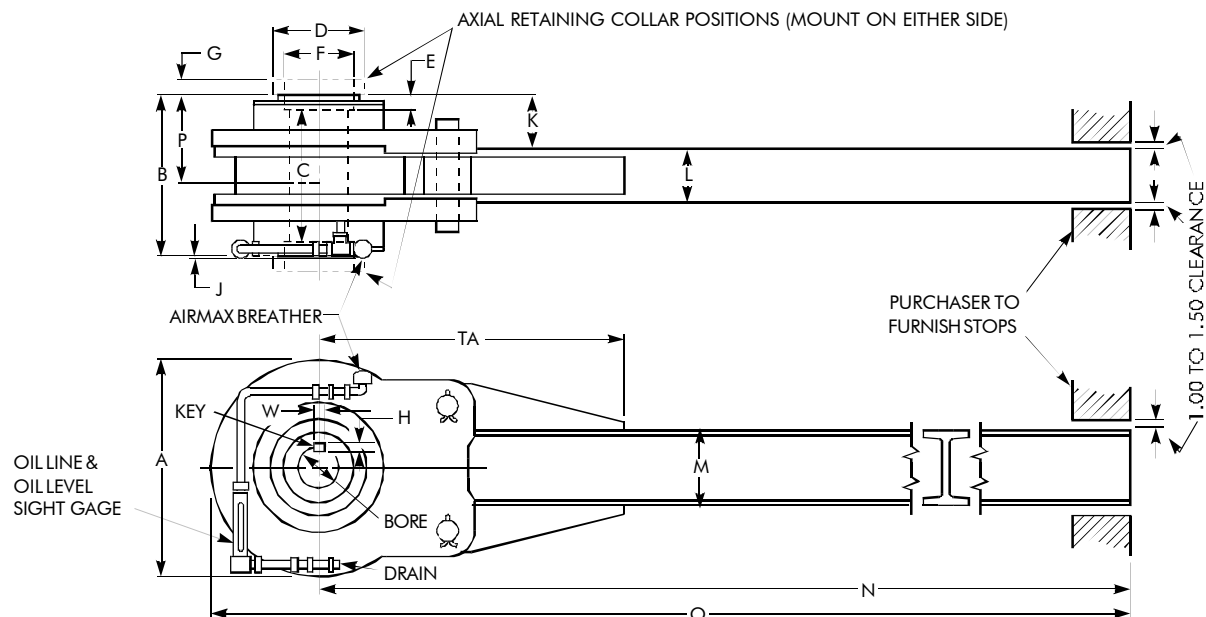

For Bore and Keyway Sizes and Tolerances, Refer to Pages 18 thru 20

BACKSTOP SIZE ★	Torque Rating (lb-ft)	Max † Over-running Speed (rpm)	Bore ‡		A	B	C	D	E	F □	G ■	J Max	K	L	M	N	O	P ■	TA Max	Wt-lb •
			Min	Max																
1075NRT	10,000	450	1.94	3.94	11.6	8.4	7.6	5.00♦	.40	3.96	.70	2.40	2.8	2.8	4.0	36.0	41.8	6.2	15.87	155
1085NRT	16,000	350	2.94	5.19	14.1	8.4	7.6	6.50*	.40	5.21	.70*	3.62	2.6	3.0	5.0	48.0	55.1	6.2	24.62	270
1095NRT	28,000	300	3.44	5.50	15.4	10.6	9.8	7.20	.40	5.91	.80♥	3.20	3.5	3.6	6.0	54.0	61.7	8.1	25.70	390
1105NRT	45,000	180	4.94	7.44	19.3	10.6	9.8	9.20▲	.40	8.50	1.00▲	2.70	3.2	4.1	8.0	66.0	75.7	8.1	25.40	620
1115NRT	75,000	150	5.94	8.44	21.5	11.6	10.6	10.50♣	.50	9.25	1.24	3.00	3.5	4.6	10.0	72.0	82.8	9.0	27.39	870
1125NRT	105,000	135	7.25	9.00	24.5	12.2	11.2	12.12	.50	11.00	1.24	3.16	3.6	5.0	12.0	78.0	90.3	9.6	29.60	1130
1135NRT	150,000	125	8.50	10.50	27.0	14.0	13.0	13.60	.50	10.52	1.24	2.60	4.3	5.5	12.0	82.0	95.5	11.4	32.59	1460
1145NRT	212,000	115	9.00	12.00	31.0	14.0	13.0	14.94	.50	12.02	1.24	1.62	4.2	5.6	15.0	88.0	103.5	11.4	36.90	1880
1155NRT	249,000	100	10.50	13.25	35.0	14.3	13.3	17.40	.50	13.27	1.50	1.94	4.1	6.0	18.0	94.0	111.5	11.5	42.15	2670
1165NRT	346,000	85	12.50	15.50	37.2	16.6	15.6	19.80	.50	15.52	2.00	2.54	4.8	6.3	20.0	100.0	118.6	13.8	60.85	3120
1175NRT	519,000	80	13.50	17.50	43.6	17.4	16.4	23.00	.50	17.52	2.00	2.60	5.1	7.3	24.0	120.0	141.8	14.3	51.08	4800
1185NRT	747,000	70	15.50	20.00	50.0	18.0	17.0	24.90	.50	20.02	2.00	2.44	4.0	10.1	27.2	120.0	145.0	14.7	52.15	6625

★ Dimensions are for reference only and are subject to change without notice unless certified.

† Refer to the Factory for higher maximum overrunning speeds.

‡ Key is furnished by the Factory.

• Weight shown is for backstop with minimum bore and without oil.

■ Dimension P is minimum required shaft engagement; see Table 1 for minimum key engagement (Shaft and key stresses). Dimension G is the retaining collar thickness for one collar. Size 1075 bores over 3.50", Size 1085 bores over 4.75", and Size 1115 bores over 8.00" require two collars (one on each side) or one collar with a step in the shaft. Check usable shaft length if two (2) collars are used.

Mounting Positions — The backstop rotational axis must be horizontal within 5°.

The backstop and torque arm may be mounted at any desired angle, but the position must be specified to permit furnishing of oil lines to suit the mounting. Horizontal or near horizontal mounting of the torque arm provides maximum bearing life.

♦ Size 1075 with bores over 3.4375", D = 6.50".

* Size 1085 with bores over 4.75", D = 7.20", G = .80".

▲ Size 1105 with bores over 6.9375", D = 10.50", G = 1.24".

♣ Size 1115 with bores over 8.00", D = 12.12".

□ Counterbore is for manufacturing.

Purchaser — The purchaser is responsible for assembling the backstop retaining collar (when furnished), oil line, oil level sight gauge, air vent, and for furnishing the oil and the torque arm stirrup per the Rexnord service manual. A 125 micro inch, or finer, shaft finish is recommended. MOUNT IN ANY POSITION

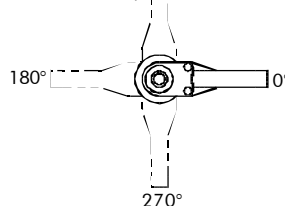

NOTE: Electronic drawings are available from our Website: http://pt.rexnord.com/customer_support/drawings

Type NRT Dimensions — Millimeters

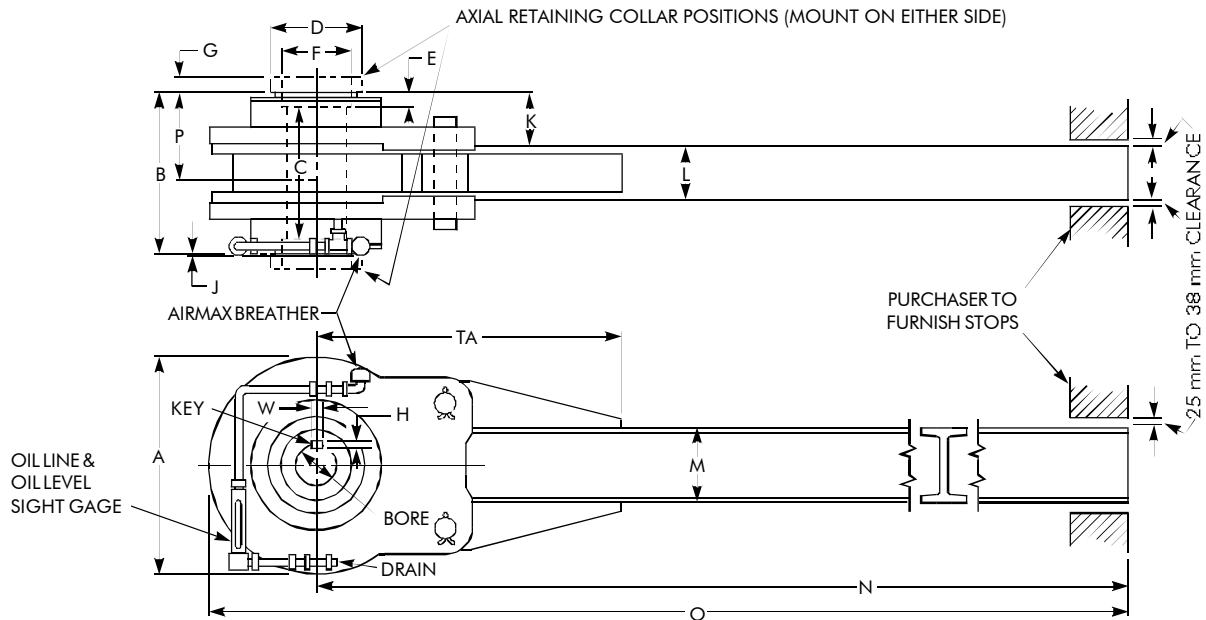

For Bore and Keyway Sizes and Tolerances, Refer to Pages 18 thru 20

BACKSTOP SIZE ★	Torque Rating (Nm)	Max † Over-running Speed (rpm)	Bore ‡		A	B	C	D	E	F □	G ■	J Max	K	L	M	N	O	P ■	TA Max	Wt-kg●
			Min	Max																
1075NRT	13 550	450	50	100	295	213	193	127 ◆	10	101	18	61	71	71	102	914	1062	158	403	70
1085NRT	21 680	350	75	130	358	213	193	165 ★	10	132	18 ★	92	66	76	127	1219	1400	158	625	122
1095NRT	37 940	300	85	150	391	269	249	183 ♥	10	150	20 ▼	81	89	91	152	1372	1567	206	653	177
1105NRT	60 975	180	125	200	490	269	249	234 ▲	10	216	25 ▲	69	81	104	203	1676	1923	206	645	281
1115NRT	101 625	150	150	225	546	295	269	267 ♣	13	235	32	76	89	117	254	1829	2103	229	696	395
1125NRT	142 275	135	185	240	622	310	284	308 ⊙	13	279	32	80	91	127	305	1981	2294	244	752	513
1135NRT	203 250	125	215	270	686	356	330	345	13	267	32	66	109	140	305	2083	2426	290	828	662
1145NRT	287 260	115	225	300	787	356	330	379	13	305	32	41	107	142	381	2235	2629	290	937	853
1155NRT	337 395	100	265	350	889	363	338	442	13	337	38	49	104	152	457	2388	2832	292	1071	1211
1165NRT	468 830	85	320	405	945	422	396	503	13	394	51	65	122	160	508	2540	3012	351	1546	1415
1175NRT	703 245	80	345	465	1107	442	417	584	13	445	51	66	130	185	610	3048	3602	363	1297	2177
1185NRT	1 012 185	70	390	510	1270	457	432	632	13	509	51	62	102	257	691	3048	3683	373	1325	3005

★ Dimensions are for reference only and are subject to change without notice unless certified.

† Refer to the Factory for higher maximum overrunning speeds.

‡ Backstops are provided with standard metric keys and keyways per ISO 773 and DIN 6885-1 Standard D10 clearance fit.

● Weight shown is for backstop with minimum bore and without oil.

■ Dimension P is minimum required shaft engagement; see Table 1 for minimum key engagement (Shaft and key stresses). Dimension G is the retaining collar thickness for one collar. Size 1075 bores over 90 mm, Size 1085 bores over 121 mm, Size 1095 over 140 mm, Size 1105 bores over 180 mm, Size 1115

bores over 205 mm, and Size 1125 bores over 230 mm" require two collars (one on each side) or one collar with a step in the shaft. Check usable shaft length if two (2) collars are used.

◆ Size 1075 with bores over 90 mm, D = 165 mm.

★ Size 1085 with bores over 120 mm, D = 183 mm, G = 20 mm.

♥ Size 1095 with bores over 135 mm, D = 234 mm, G = 25 mm.

▼ Size 1105 with bores over 175 mm, D = 267 mm, G = 32 mm.

♣ Size 1115 with bores over 200 mm D = 308 mm.

⊙ Size 1125 with bores over 230 mm, D = 345 mm.

□ Counterbore is for manufacturing.

Mounting Positions — The backstop rotational axis must be horizontal within 5°.

The backstop and torque arm may be mounted at any desired angle, but the position must be specified to permit furnishing of oil lines to suit the mounting. Horizontal or near horizontal mounting of the torque arm provides maximum bearing life.

Purchaser — The purchaser is responsible for assembling the backstop retaining collar (when furnished), oil line, oil level sight gauge, air vent, and for furnishing the oil and the torque arm stirrup per the Rexnord service manual. A 3.2 micro meter, or finer, shaft finish is recommended.

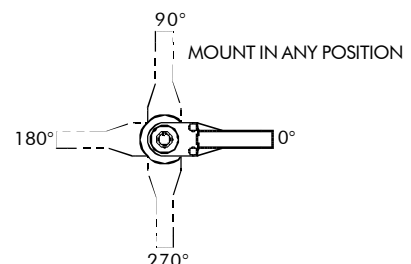

NOTE: Electronic drawings are available from our Website: http://pt.rexnord.com/customer_support/drawings

Backstop Operation — NRT

Overrunning

Figure 6 — For most of its operating life a backstop is in the overrunning mode of operation.

The rollers, roller cage, and stop lugs rotate with the inner cam as a unit since they are connected by the energizing springs.

The outer race does not rotate since it is bolted to the end covers, which are held by the backstop torque arm.

While overrunning, the rollers roll on the outer race and slide on the inner cam ramps. Friction and centrifugal force tend to lift the rollers off the cam, minimizing contact and wear (Figure 7).

Figure 6

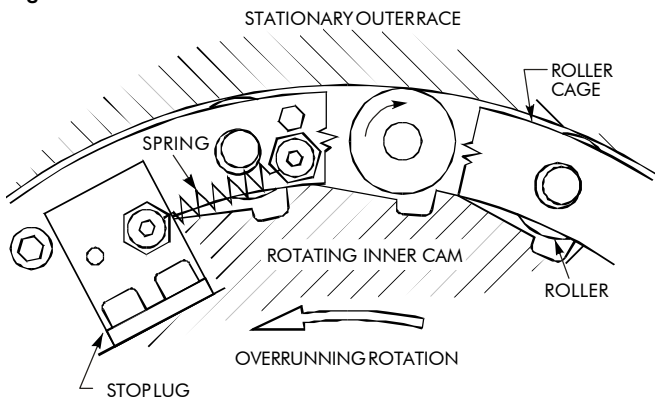
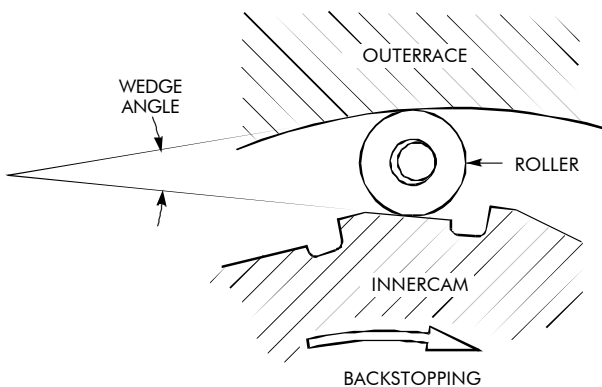

Figure 8



The energizing springs stretch during overrunning to provide tension to the roller cage assembly (Figure 6). This tension keeps the rollers ready for instantaneous backstopping engagement and minimizes the relative rotation of the roller cage to the inner cam.

The stop lugs axially position the roller cage assembly on the inner cam. They also prevent the roller cage from rotating too far which would cause the rollers to strike the upright side of the adjacent ramp. Maximum relative rotation of the roller cage assembly and inner cam during overrunning is between .040" (1,02 mm) and .100" (2,04 mm), depending on size, as limited by the stop lugs.

Backstopping

Figure 8 — As the rotating shaft stops and attempts to reverse, the inner cam is instantly stopped by the wedging action of the rollers in the annular openings between the cam ramps and outer race.

From the outer race the backstopping torque is carried through the end covers to the torque arm and the adjoining superstructure.

Figure 9 — All rollers are engaged simultaneously since they are positioned by the spring loaded roller cage.

Load division between the rollers is assured by machining accuracy of the inner cam ramps, rollers, roller cage, and outer race.

Figure 7

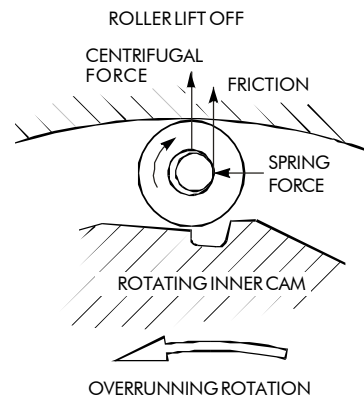
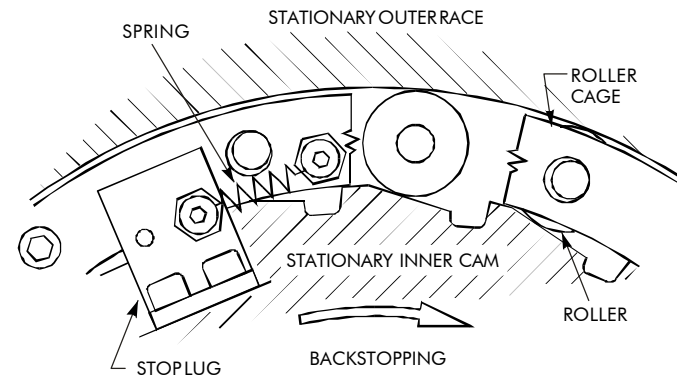

Figure 9



As additional backstopping torque is applied to the inner cam, the rollers will tend to move deeper into the wedging position, thereby increasing the resistance to slippage.

Relative rotational movement between initial backstopping engagement at no load to backstopping at full catalog rating is approximately $1\frac{1}{2}^{\circ}$ to 3° .

The torque capacity of the backstop is based on the tangential friction resistance force at the outer race developed by the compressive force between the inner cam ramps, rollers, and outer race.

The maximum torque capacity of the backstop is limited by the Hertzian contact stress at inner cam/roller and roller/outer race contact points, bending strength of torque arm, and hoop stress of outer race.

Backstop Operation — NRT Styles B and C

The NRT styles B and C backstops are a new addition to the Rexnord line of backstops. These backstops operate on the proven principal of sprag technology, which has been around since the mid 1950's. The sprag technology has advanced over the years with improvements in materials and heat treatment processes.

NRT Style B

The NRT Style B backstops are designed for lower operating speed applications. The design features three primary components: a cylindrical inner race, a cylindrical outer race, and a sprag cage consisting of a full complement of individually tensioned sprags.

The proprietary geometry of the sprags allows for the one-way operation of the backstop (see illustration). During normal operation of the backstop, the inner race rotates in the free direction while the outer race remains stationary. During an attempted reversal of the backstop, torque is instantly transmitted from the inner race, through the sprags, to the outer race, which is held stationary with a torque arm. The features of the backstops are zero backlash, large bore capacity, large torque capacity and grease purge cavities on sizes 1055, 1065, and 1085.

NOTE: If all the upgraded features of the NRT style backstop are not required, then consider the 1055, 1065, and 1085 NRT Style B backstops as a less expensive alternative to the NRT backstop design.

(1055, 1065, and 1085 ONLY)

Figure 10

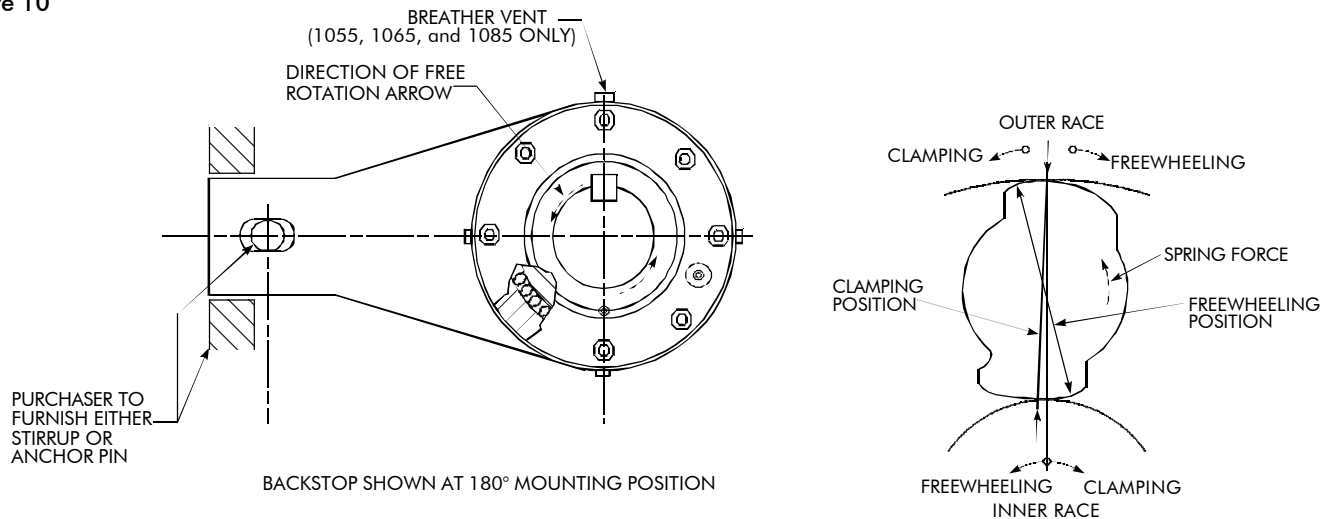

NRT Style C

The NRT Style C backstops are offered in sizes 1055 and 1065, and are designed for a higher operating speed than the Style B. The centrifugal lift-off sprag is a feature exclusive to the NRT Style C design in the NRT family of Rexnord backstops. This feature incorporates a special sprag design with an offset center of gravity. During overrunning, centrifugal force F_c causes the individually tensioned sprags to lift off the outer race, thereby allowing the

sprags to operate without wear (Figure 11). When the overrunning speed of the backstop has reduced sufficiently so that the centrifugal force is less than the spring force, the sprags will return to their contact positions and stand ready to transmit torque without backlash (Figure 12). Special features are increased service life, reduced heat generated, high overrunning speeds, and sealed for life design (minimum maintenance).

Figure 11 OVERRUNNING (LIFT OFF)

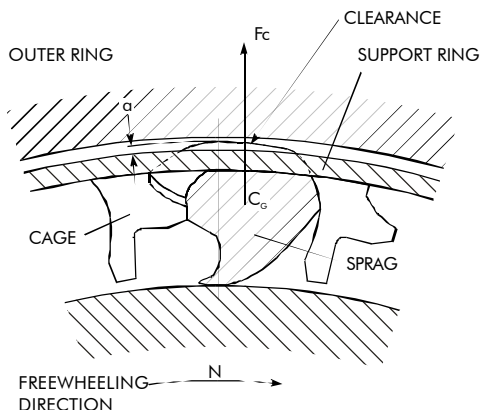
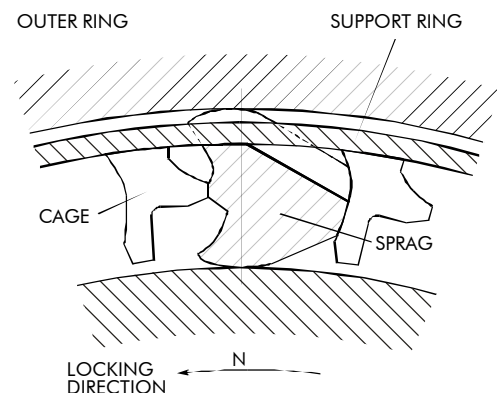

Figure 12 BACKSTOPPING



Service Parts (Type NRT Backstops)

INTRODUCTION — Give complete data shown on the backstop nameplate and name of parts required. Complete data will assure receipt of the correct parts.

COVER GASKETS — When end covers are removed to replace oil seals, order new cover gaskets to prevent oil leakage.

Type NRT — Backstop Parts

Part Description
Lubrication Assembly ★
Air Vent Assembly
Oil Level Gauge
Torque Arm
Bearing (each)
Oil Seal (each)
Cover Fasteners (set) †
Cover Gasket (each)

★ Assembly shown includes sight gauge, air vent and all piping, tees, and elbows required.

† Cover fastener; two sets are required per backstop.

PART DESCRIPTIONS

1. End Cover
2. Gasket
3. Bearing
4. Outer Seal
5. Inner Seal
6. Rollers

7. Roller Cage End Rings (2)
8. Inner Cam
9. Outer Race
10. Labyrinth Shroud
(Not available on all sizes)

11. Optional Axial Retaining Collar
12. Stop Lug

13. Roller Cage Fasteners
14. Rotation Direction Plate
15. End Cover Fasteners
16. Torque Arm
17. Torque Arm Pin

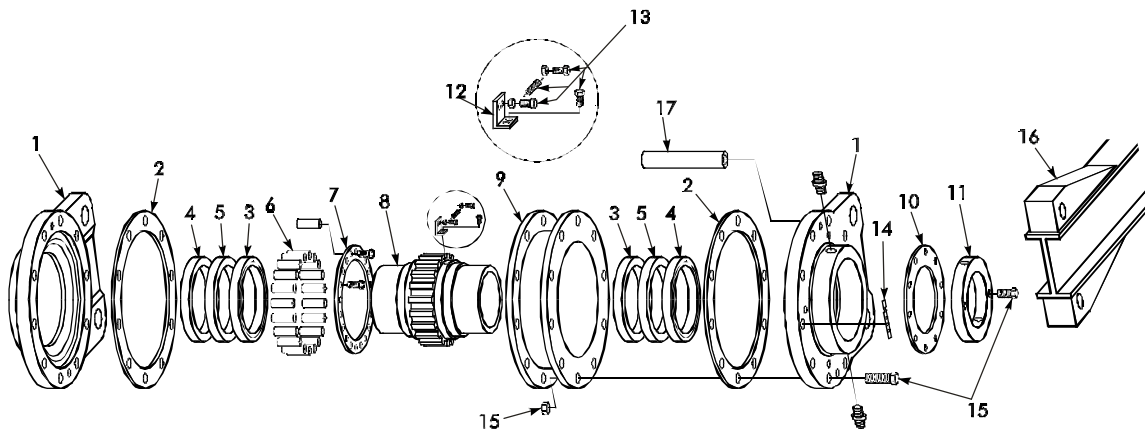

Dismantling, Repair, & Parts Replacement

WARNING: DO NOT attempt to service or remove backstop before removing load.

An important part of the Falk NRT backstop manufacturing process is the full load and overrunning testing with specially instrumented equipment. Consequently, return NRT backstops to Rexnord for repair and full load testing.

Except for replacement of oil seals (Service Manual 568-130), NRT backstops should not be dismantled or repaired in the field. If seals are to be replaced, it is important that the cam and roller assemblies not be removed from the outer race. Removal will void applicable warranties.

When writing to Rexnord Service Parts Department concerning required service, state nature of problem and give complete data from backstop nameplate, M. O. number, size, date, etc.

Contact: Gear.ServiceParts@rexnord.com

Engineering Recommendations

Backstop Applications — Falk NRT and NRTH backstops are designed to prevent reverse rotation in applications such as inclined conveyors, bucket elevators, fans, rotary pumps, and kilns. If local safety codes permit, the backstop may be used as a backup for a brake on those applications, but NOT in people conveying systems such as elevators, manlifts, ski tows or ski lifts, Also DO NOT use the backstop as a substitute for a brake.

Indexing — Falk NRT and NRTH Backstops can be used for indexing service, provided there is one complete revolution of the backstop between backstopping cycles. Refer application data to the Factory for selection.

Safety Standards — The backstop and normal associated equipment (shaft, pulleys, etc.) involve moving parts; therefore, consult local, state, OSHA, and ANSI safety codes for proper guarding of revolving parts and possible pinch points. (A pinch point occurs at the contact point between the backstop torque arm and support, and between the torque arm and stirrup.)

Chemical Atmospheres — The backstop may be damaged if exposed to certain types of chemicals or vapors; for example, potash dust, chlorine gas, carbon tetrachloride, etc. These materials may cause deterioration of the seals or aluminum roller cage rings.

Operating Temperature — Enclosure of the backstop may cause overheating. Provide adequate ventilation. Backstop operating temperatures, at maximum overrunning speed, may reach 200°F (93°C). Determine the effect of this temperature on the driven equipment and provide cooling if necessary.

If a backstop operates in the sun at ambient temperatures over 100°F (38°C), then special measures should be taken to protect the backstop from solar energy. This protection can consist of a canopy over the backstop or reflective paint on the backstop. If neither is possible, a cooling device such as a fan may be required to prevent the sump temperature from exceeding the allowable maximum of 200°F (93°C).

Keys & Keyways — Keys used with NRT and NRTH backstops are furnished by the Factory. Keys are either mild steel, cold drawn 1045 steel or heat treated alloy steel (310-350 HB). Use only those keys provided by the Factory (see Table 1).

Do not use sled runner type keyway. It may induce undue forces on backstop.

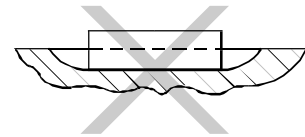

Engineering Recommendations

Table 1 — Shaft and Keyway Dimensions — Inches *

BACKSTOP SIZE	Nominal Shaft Diameter (Over–Thru)	Shaft Keyway		Backstop Keyway		Key			
		Width	Depth	Width	Depth	Width x Height	Key Length Furnished	Minimum Key Engagement	Key ★ Material †
1045NRTH	1.3750 -2.2500	0.500	0.250	0.500	0.250	0.500 X 0.500	3.500	2.625	3
	2.2500 -2.5000	0.625	0.313	0.625	0.125	0.625 X 0.438	3.500	2.625	3
1055NRTH	1.7500 -2.2500	0.500	0.250	0.500	0.250	0.500 X 0.500	7.500	5.500	3
	2.2500 -2.7500	0.625	0.313	0.625	0.313	0.625 X 0.625	7.500	5.500	3
	2.7500 -3.2500	0.750	0.375	0.750	0.375	0.750 X 0.750	7.500	5.500	3
	3.2500 -3.3750	0.875	0.438	0.875	0.438	0.875 X 0.875	7.500	5.500	3
1065NRTH	2.5000 -2.7500	0.625	0.313	0.625	0.313	0.625 X 0.625	8.000	5.875	3
	2.7500 -3.2500	0.750	0.375	0.750	0.375	0.750 X 0.750	8.000	5.875	3
	3.2500 -3.7500	0.875	0.438	0.875	0.438	0.875 X 0.875	8.000	5.875	3
	3.7500 -4.0000	1.000	0.500	1.000	0.500	1.000 X 1.000	8.000	5.875	3
	4.0000 -4.5000	1.000	0.500	1.000	0.250	1.000 X 0.750	8.000	5.875	3
1085NRTH	3.9375 -4.5000	1.000	0.500	1.000	0.500	1.000 X 1.000	7.625	5.875	3
	4.5000 -4.7500	1.250	0.625	1.250	0.625	1.250 X 1.250	7.625	5.875	3
	4.7500 -5.4375	1.250	0.625	1.250	0.313	1.250 X 0.938	7.625	5.875	3
1075NRT	1.9375	.500	.250	.500	.250	.500 x .500	7.25	7.25	2
	1.9375 -2.2500	.500	.250	.500	.250	.500 x .500	7.25	7.25	2
	2.2500 -2.7500	.625	.313	.625	.313	.625 x .625	6.00	6.00	2
	2.7500 -3.2500	.750	.375	.750	.375	.750 x .750	7.00	5.50	1
	3.2500 -3.5625	.875	.438	.875	.438	.875 x .875	5.50	4.00	1
	3.5625 -3.7500	.875	.313	.875	.323	.875 x .625	7.25	5.00	1
	3.7500 -3.9375	1.000	.500	1.000	.250	1.000 x .750	7.00	5.00	1
1085NRT	2.9375	.750	.375	.750	.375	.750 x .750	7.00	6.50	2
	2.9375 -3.2500	.750	.375	.750	.375	.750 x .750	7.00	6.50	2
	3.2500 -3.7500	.875	.438	.875	.438	.875 x .875	5.50	5.00	2
	3.7500 -4.5000	1.000	.500	1.000	.500	1.000 x 1.000	7.00	5.00	1
	4.5000 -4.7500	1.250	.625	1.250	.625	1.250 x 1.250	7.00	3.50	1
	4.7500 -5.1875	1.250	.625	1.250	.250	1.250 x .8750	7.00	7.00	1
1095NRT	3.4375	.875	.438	.875	.438	.875 x .875	9.00	8.00	2
	3.4375 -3.7500	.875	.438	.875	.438	.875 x .875	9.00	8.00	2
	3.7500 -4.5000	1.000	.500	1.000	.500	1.000 x 1.000	9.00	8.50	1
	4.5000 -5.0000	1.250	.625	1.250	.625	1.250 x 1.250	7.00	6.00	1
1105NRT	5.0000 -5.5000	1.250	.625	1.250	.500	1.250 x 1.125	7.00	6.50	1
	4.9375	1.250	.625	1.250	.625	1.250 x 1.250	7.00	6.50	2
	4.9375 -5.5000	1.250	.625	1.250	.625	1.250 x 1.250	7.00	6.50	2
	5.5000 -6.5000	1.500	.750	1.500	.750	1.500 x 1.500	8.00	6.50	1
1115NRT	6.5000 -7.4375	1.750	.750	1.750	.750	1.750 x 1.500	9.00	5.50	1
	5.9375	1.500	.750	1.500	.750	1.500 x 1.500	8.00	7.50	2
	5.9375 -6.5000	1.500	.750	1.500	.750	1.500 x 1.500	8.00	7.50	2
	6.5000 -7.5000	1.750	.750	1.750	.750	1.750 x 1.500	9.00	9.00	1
	7.5000 -8.0000	2.000	.750	2.000	.750	2.000 x 1.500	9.00	8.00	1
1125NRT	8.0000 -8.4375	2.000	.750	2.000	.500	2.000 x 1.250	10.50	10.50	1
	7.2500	1.750	.750	1.750	.750	1.750 x 1.500	11.00	11.00	1
	7.2500 -7.5000	1.750	.750	1.750	.750	1.750 x 1.500	11.00	11.00	1
1135NRT	7.5000 -9.0000	2.000	.750	2.000	.750	2.000 x 1.500	11.00	10.50	1
	8.5000	2.000	.750	2.000	.750	2.000 x 1.500	11.00	10.00	2
	8.5000 -9.0000	2.000	.750	2.000	.750	2.000 x 1.500	11.00	10.00	2
1145NRT	9.0000 -10.5000	2.500	.875	2.500	.875	2.500 x 1.750	12.00	9.50	1
	9.0000	2.000	.750	2.000	.750	2.000 x 1.500	13.00	13.00	2
	9.0000 -11.0000	2.500	.875	2.500	.875	2.500 x 1.750	12.00	11.50	2
1155NRT	11.0000 -12.0000	3.000	1.000	3.000	1.000	3.000 x 2.000	13.00	11.00	1
	10.5000	2.500	1.250	2.500	1.250	2.500 x 2.500	12.00	11.00	2
	10.5000 -11.0000	2.500	1.250	2.500	1.250	2.500 x 2.500	12.00	11.00	2
	11.0000 -13.0000	3.000	1.000	3.000	1.000	3.000 x 2.000	13.00	13.00	2
1165NRT	13.0000 -13.2500	3.500	1.250	3.500	1.250	3.500 x 2.500	12.00	9.00	2
	12.5000	3.000	1.000	3.000	1.000	3.000 x 2.000	15.50	12.00	2
	12.5000 -13.0000	3.000	1.000	3.000	1.000	3.000 x 2.000	15.50	12.00	2
	13.0000 -15.0000	3.500	1.250	3.500	1.250	3.500 x 2.500	12.00	12.00	2
1175NRT	15.0000 -15.5000	4.000	1.500	4.000	1.500	4.000 x 3.000	13.00	9.00	2
	13.5000	3.500	1.250	3.500	1.250	3.500 x 2.500	16.00	15.50	2
	13.5000 -15.0000	3.500	1.250	3.500	1.250	3.500 x 2.500	16.00	15.50	2
1185NRT	15.0000 -17.5000	4.000	1.500	4.000	1.500	4.000 x 3.000	17.00	13.50	2
	15.5000	4.000	1.500	4.000	1.500	4.000 x 3.000	17.00	13.50	2
	15.5000 -18.0000	4.000	1.500	4.000	1.500	4.000 x 3.000	17.00	13.50	2
1185NRT	18.0000 -20.0000	5.000	1.750	5.000	1.750	5.000 x 3.500	14.00	13.50	2
	18.0000	5.000	1.750	5.000	1.750	5.000 x 3.500	14.00	13.50	2

★ Keys are furnished by the Factory to suit shaft and backstop keyways. Keys are either cold drawn 1045 or heat treated alloy steel (310 - 350 HB). Only use keys furnished by the Factory. Shaft keyway depth tolerance of -.000" -.010" is recommended.

† Number 1 keys are cold drawn 1045 steel, Number 2 keys are heat treated alloy steel (310 - 350 HB) , and Number 3 keys are Mild Steel.

* Backstop supplied with H7 bore assuming h6 shaft (ANSI tolerance specification). Backstop key and keyway tolerance per FDN 430-152 assuming shaft keyway per ANSI B17.1.

Engineering Recommendations

Table 1A — Shaft and Keyway Dimensions — Millimeters *

BACKSTOP SIZE	Nominal Shaft Diameter (Over-Thru)	Shaft Keyway		Backstop Keyway		Key			
		Width	Depth	Width	Depth	Width x Height	Key Length Furnished	Minimum Key Engagement	Key ★ Material ‡
1045NRTH	45 -50	14.0	5.5	14.0	3.8	14 X 9	88.9	66.7	3
	50 -58	16.0	6.0	16.0	4.3	16 X 10	88.9	66.7	3
	58 -60	18.0	7.0	18.0	2.3	18 X 9	88.9	66.7	3
1055NRTH	45 -50	14.0	5.5	14.0	3.8	14 X 9	190.5	139.7	3
	50 -58	16.0	6.0	16.0	4.3	16 X 10	190.5	139.7	3
	58 -65	18.0	7.0	18.0	4.4	18 X 11	190.5	139.7	3
	65 -75	20.0	7.5	20.0	4.9	20 X 12	190.5	139.7	3
	75 -85	22.0	9.0	22.0	5.4	22 X 14	190.5	139.7	3
	85 -95	25.0	9.0	25.0	5.4	25 X 14	190.5	139.7	3
	95 -98	28.0	10.0	28.0	3.2	28 X 13	190.5	139.7	3
1065NRTH	65 -75	20.0	7.5	20.0	4.9	20 X 12	203.2	149.2	3
	75 -85	22.0	9.0	22.0	5.4	22 X 14	203.2	149.2	3
	85 -95	25.0	9.0	25.0	5.4	25 X 14	203.2	149.2	3
	95 -110	28.0	10.0	28.0	6.4	28 X 16	203.2	149.2	3
	110 -115	32.0	11.0	32.0	3.5	32 X 14	203.2	149.2	3
1085NRTH	100 -110	28.0	10.0	28.0	6.4	28 X 16	193.7	149.2	3
	110 -130	32.0	11.0	32.0	7.4	32 X 18	193.7	149.2	3
	130 -140	36.0	12.0	36.0	3.8	36 X 15	193.7	149.2	3
1075NRT	50	14.0	5.5	14.0	3.8	14 X 9	210	210	2
	50 - 58	16.0	6.0	16.0	4.3	16 X 10	210	210	2
	58 - 65	18.0	7.0	18.0	4.4	18 X 11	210	210	2
	65 - 75	20.0	7.5	20.0	4.9	20 X 12	200	185	2
	75 - 85	22.0	9.0	22.0	5.4	22 X 14	180	160	2
	85 - 95	25.0	9.0	25.0	5.4	25 X 14	150	140	2
	95 - 100	28.0	10.0	28.0	3.2	28 X 13	180	140	2
1085NRT	75	20.0	7.5	20.0	4.9	20 X 12	210	210	2
	75 - 85	22.0	9.0	22.0	5.4	22 X 14	210	210	2
	85 - 95	25.0	9.0	25.0	5.4	25 X 14	210	210	2
	95 - 110	28.0	10.0	28.0	6.4	28 X 16	180	170	2
	110 - 130	32.0	11.0	32.0	7.4	32 X 18	150	120	2
1095NRT	85	22.0	9.0	22.0	5.4	22 X 14	265	265	2
	85 - 95	25.0	9.0	25.0	5.4	25 X 14	265	265	2
	95 - 110	28.0	10.0	28.0	6.4	28 X 16	265	265	2
	110 - 130	32.0	11.0	32.0	7.4	32 X 18	230	225	2
	130 - 150	36.0	12.0	36.0	7.4	36 X 19	180	160	2
1105NRT	120 - 130	32.0	11.0	32.0	7.4	32 X 18	265	265	2
	130 - 150	36.0	12.0	36.0	8.4	36 X 20	265	265	2
	150 - 170	40.0	13.0	40.0	9.4	40 X 22	220	210	2
	170 - 200	45.0	15.0	45.0	10.4	45 X 25	170	165	2
1115NRT	150	36.0	12.0	36.0	8.4	36 X 20	290	290	2
	150 - 170	40.0	13.0	40.0	9.4	40 X 22	290	290	2
	170 - 200	45.0	15.0	45.0	10.4	45 X 25	290	280	2
	200 - 225	50.0	17.0	50.0	11.4	50 X 28	220	220	2
1125NRT	180 - 200	45.0	15.0	45.0	10.4	45 X 25	305	305	2
	200 - 230	50.0	17.0	50.0	11.4	50 X 28	305	305	2
	230 - 240	56.0	20.0	56.0	12.4	56 X 32	280	250	2
1135NRT	210 - 230	50.0	17.0	50.0	11.4	50 X 28	350	350	2
	230 - 260	56.0	20.0	56.0	12.4	56 X 32	350	350	2
	260 - 280	63.0	20.0	63.0	12.4	63 X 32	330	315	2
1145NRT	220 - 230	50.0	17.0	50.0	11.4	50 X 28	350	350	2
	230 - 260	56.0	20.0	56.0	12.4	56 X 32	350	350	2
	260 - 290	63.0	20.0	63.0	12.4	63 X 32	350	350	2
	290 - 300	70.0	22.0	70.0	14.4	70 X 36	350	340	2
1155NRT	260 - 290	63.0	20.0	63.0	12.4	63 X 32	360	360	2
	290 - 330	70.0	22.0	70.0	14.4	70 X 36	360	360	2
	330 - 350	80.0	25.0	80.0	15.4	80 X 40	360	330	2

★ Keys are furnished by the Factory to suit shaft and backstop keyways. Keys are either cold drawn 1045 or heat treated alloy steel (310 - 350 HB). Only use keys furnished by the Factory. Shaft keyway depth tolerance of -.000 -.025mm is recommended.

‡ Number 1 keys are cold drawn 1045 steel, Number 2 keys are heat treated alloy steel (310 - 350 HB), and Number 3 keys are Mild Steel.

* Backstops supplied with E7 bore and D10keyway assuming m6 shaft diameter and h9 keyway (ISO tolerance specification).

Engineering Recommendations

Table 2 — Backstop-Shaft Fits — Inch

Nominal Diameter (From-Incl.)	Nominal Shaft Tolerance	Nominal Bore Diameter Tolerance	Bore-Shaft Clearance ★
1.2500 – 1.5000	+ .0000, – .0005	+ .0005, + .0015	.0005 – .0020
1.5000 – 2.9375	+ .0000, – .0010	+ .0005, + .0015	.0005 – .0025
3.0000 – 7.9375	+ .0000, – .0010	+ .0010, + .0025	.0010 – .0035
8.0000 – 11.9375	+ .0000, – .0010	+ .0015, + .0035	.0015 – .0045
12.0000 – 14.9375	+ .0000, – .0010	+ .0020, + .0045	.0020 – .0055
15.0000 – 20.0000	+ .0000, – .0020	+ .0020, + .0045	.0020 – .0065

★ A 125 micro inch (or finer) shaft finish and clearance fit specified above are recommended.

Table 3 — Metric Bores for Backstops

Nominal Diameter over – to (mm)	Nominal Shaft Tolerance (mm)●	Nominal Bore Tolerance (mm) †	Bore-Shaft Clearance Min-Max (mm)
30 – 50 k6	.002 / .018	.025 / .050	.007 – .048
50 – 80 m6	.011 / .030	.060 / .090	.030 – .079
80 – 120 m6	.013 / .035	.072 / .107	.037 – .094
120 – 180 m6	.015 / .040	.085 / .125	.045 – .110
180 – 250 m6	.017 / .046	.100 / .146	.054 – .129
250 – 315 m6	.020 / .052	.110 / .162	.058 – .142
315 – 400 m6	.021 / .057	.125 / .182	.068 – .161
400 – 500 m6	.023 / .063	.135 / .198	.072 – .175

● Shaft diameters from 30 – 50 mm are k6 tolerance and shaft diameters over 50 – 500 mm are m6 tolerance.

† Bore diameters from 30 – 50 mm are F7 tolerance and bore diameters over 50 mm to 500 mm are E7 tolerance

A 3.2 micro meter (or finer) shaft finish is recommended. For shaft tolerances other than those listed in the table, consult Factory for bore tolerance. (Specify your shaft tolerance.)

Table 4 — Backstop Reaction Force at Torque Arm Stirrup (Inch & Metric)

BACKSTOP SIZE	Catalog Torque Rating		N Torque Arm Length (See drawing on next page.)		.9N +/- .5" (12.7 mm)		Torque Arm Reaction Force ‡	
	lb-ft	Nm	in	mm	in	mm	lb	N
1045NRTH-B	2,100	2 847	7.00	178	6.30	160	6,000	26 688
1055NRTH-B	10,000	13 557	36.00	914	32.40	823	5,556	24 711
1055NRTH-C	4,400	5 965	36.00	914	32.40	823	2,444	10 873
1065NRTH-B	13,000	17 625	36.00	914	32.40	823	7,222	32 124
1065NRTH-C	8,400	11 388	36.00	914	32.40	823	4,667	20 757
1085NRTH-B	18,000	24,403	51.00	1295	45.90	1 166	7,059	31 398
1075NRT	10,000	13 600	36.00	914	32.50	825	5,550	24 700
1085NRT	16,000	21 700	48.00	1 219	43.00	1 095	6,700	29 800
1095NRT	28,000	38 000	54.00	1 372	48.50	1 235	10,500	46 700
1105NRT	45,000	61 000	66.00	1 676	59.50	1 510	13,600	60 500
1115NRT	75,000	102 000	72.00	1 829	65.00	1 645	20,800	92 550
1125NRT	105,000	142 000	78.00	1 981	70.00	1 785	27,000	120 100
1135NRT	150,000	203 000	82.00	2 083	74.00	1 875	36,500	162 400
1145NRT	212,000	287 000	88.00	2 235	79.00	2 010	48,300	214 850
1155NRT	249,000	338 000	94.00	2 386	84.50	2 150	53,300	237 100
1165NRT	346,000	469 000	100.00	2 540	90.00	2 285	69,200	307 850
1175NRT	519,000	704 000	120.00	3 048	108.00	2 745	86,500	384 850
1185NRT	747,000	1 013 000	120.00	3 048	108.00	2 745	124,500	553 800

‡ Reaction force is based on .9N torque arm length and 1.5 catalog rating:

$$\text{Force (lb)} = \frac{1.50 \times \text{Catalog Torque Rating (lb-ft)} \times 12 \text{ (in per ft)}}{.9N \text{ (in)}}$$

$$\text{Force((N)} = \frac{1.50 \times \text{Catalog Torque Rating} \times 1000 \text{ (mm per m)}}{.9N \text{ (mm)}}$$

For reduced length torque arms substitute actual N dimension in formula.

Engineering Recommendations

Backstop Mounting Positions — The supporting shaft must be horizontal within 5° for NRTH and NRT backstops. The backstop torque arm assembly may be rotated to any angular position, but the position must be specified by the purchaser to permit Rexnord to furnish oil lines to suit the mounting for Type NRT.

The symmetrical backstop design permits turning the backstop end for end to provide either direction of shaft rotation. The backstop overrunning (or free rotation) direction is indicated by a rotation arrow on each side of the backstop.

For NRT backstops, the purchaser is responsible for mounting the backstop retaining collar, oil line, oil level sight gauge, and air vent, and for furnishing the oil and the torque arm stirrup per the Rexnord service manual.

Torque Arm Stirrups — Locate torque arm stirrup at .9N as illustrated at right. Design the stirrup to withstand the Torque Arm Reaction Force listed in Table 4. If the stirrup must be located closer, design the stirrup to withstand the force developed by the actual torque applied to the backstop. Use the following formula to determine the force.

$$\text{Actual Reaction Force} = \frac{\text{Drive Pulley Peak Torque}}{\text{Actual Application Dimension } N}$$

The torque arm must be free to move within the stirrup. Provide clearance on three sides as shown at right. DO NOT restrict torque arm movement by welding or securing to any supporting structure.

Locate the torque arm support surface parallel ($\pm 1/2^\circ$) to the axis of the shaft on which the backstop is mounted.

A boot or hood is recommended for all positions of the torque arm to prevent accumulation of material around the torque arm stirrup. This also provides a guard against a possible pinch point. DO NOT restrict movement of the torque arm.

Grease Purged Seals — The option of adding grease is the purchaser's. Adding grease to the outer cavity seal is NOT RECOMMENDED if grease could contaminate the material being processed as in the food and drug industries. The company adds grease between the inner and outer seals for NRT backstops. DO NOT purge this inner cavity in the field.

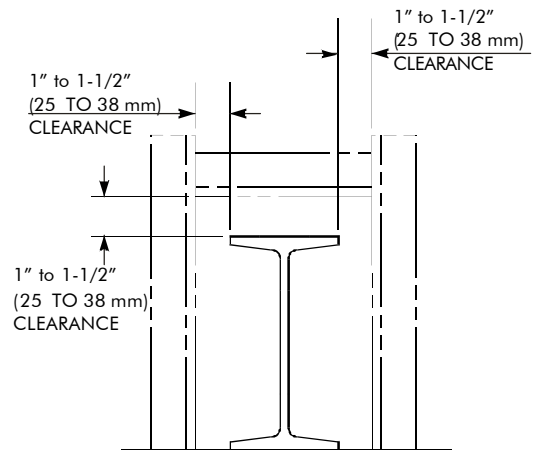
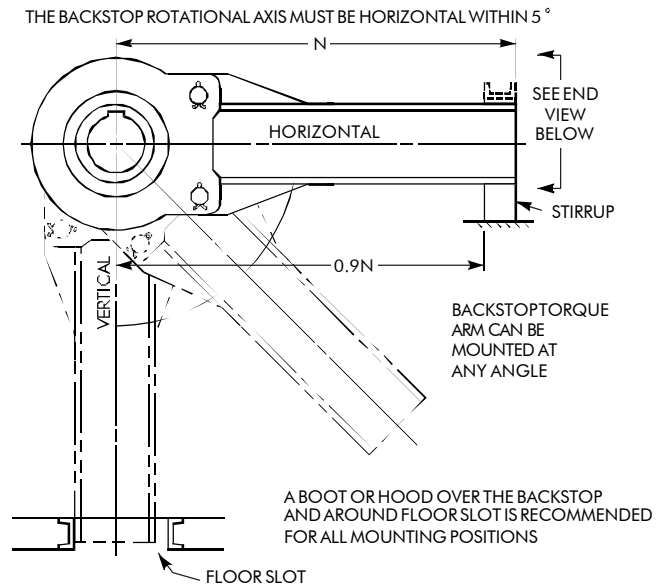

END VIEW

Falk Type NRT & NRTH Backstop Interchangeability Chart

Torque Rating lb-ft	REXNORD/FALK™ ★ NRTH & NRT						ALTRA INDUSTRIAL MOTION® (formerly MARLAND®) TYPE BC, BC-M, & BC-MA						ALTRA INDUSTRIAL MOTION® (formerly FORMSPRAG®) TYPE LLH-S & LLH-R					
	SIZE	Bore Range		Outside Dia	Width w/o Axial Retention	Wt lb	SIZE	Bore Range		Outside Dia	Width w/o Axial Retention	Wt lb	SIZE	Bore Range		Outside Dia	Width w/o Axial Retention	Wt lb
		Min	Max					Min	Max					Min	Max			
1,808
2,100
2,250
3,000	1045NRTHB	1.75	2.50	6.50	4.19	29
3,333	3MA/2M/200	2.44	2.94	8.2	5.3	100
4,000	700S	1.88	3.25	7.1	6.4	160
4,342
4,400	1055NRTHC	1.75	3.75	9.75	8.02	157
5,000
5,788	6MA/4M/275	2.94	3.69	9.8	6.3	150
6,000
6,500
6,666
6,800	750S	2.25	3.44	8.0	7.4	215
7,960
8,400	1065NRTHC	2.50	4.50	10.50	8.52	190
10,000	1055NRTHB	1.75	3.75	9.75	8.02	157
	1075NRT	1.94	3.94	11.6	8.4	155
11,500	800S	2.63	4.44	10.0	7.6	325
11,577
11,667
12,000	12MA/8M/350	3.94	4.50	11.5	6.5	220
13,000	1065NRTHB	2.50	4.50	10.50	8.64	190
16,000	1085NRT	2.94	5.19	14.1	8.4	270
18,000	1085NRTHB	3.94	5.44	12.00	8.52	260	18MA/12M/425	4.44	5.44	13.5	7.1	330	900S	3.63	5.44	10.0	8.0	570
18,100
19,000
20,833
27,000	27MA/18M/500	5.68	6.50	15.0	8.4	450	1027S	4.94	7.00	15.0	8.2	750
27,083
27,485
28,000	1095NRT	3.44	5.50	15.4	10.6	390
30,000
36,165
45,000	1105NRT	4.94	7.44	19.3	10.6	620	45MA/30M/550	5.94	7.00	17.5	8.8	600	1051S	4.94	7.00	15.0	9.5	800
45,833
63,000	63MA/42M/600	6.94	8.00	19.6	9.3	830	1250R	5.25	8.00	19.6	9.3	830
65,000	1250S	6.75	9.00	20.0	9.8	1,400
65,100
66,667
75,000	1115NRT	5.94	8.44	21.5	11.6	870
90,000	90MA/60M/700	8.00	9.00	23.0	10.5	1,130	1300S/1300R	7.94/5.75	10.0/9.00	21.5/23.0	9.8/10.5	1,700/1,130
90,410
92,500
105,000	1125NRT	7.25	9.00	24.5	12.2	1,130
130,190
135,000	135MA/90M/800	6.75	10.00	25.8	11.8	1,500	1375S/1375R	8.94/6.75	11.0/10.50	24.5/25.7	9.8/11.75	2,200/1,500
145,833
150,000	1135NRT	8.50	10.50	27.0	14.0	1,460	180MA/120M/900	7.25	11.75	30.3	12.6	2,100	2000R	7.25	11.75	30.3	12.6	2,100
180,000
195,290
200,000	2000S	10.94	13.25	30.0	10.4	3,200
208,333
212,000	1145NRT	9.00	12.00	31.0	14.0	1,880
231,460
240,000	240MA/160M/1000	8.25	14.00	34.5	16.0	2,700	2400R	8.75	14.0	34.5	16.0	2,700
249,000	1155NRT	10.50	13.25	35.0	14.3	2,670
250,000
265,000
300,000	300MA	8.25	14.0	34.5	17.0	3,800	2400S	13.00	15.50	36.0	10.6	4,200
316,667
346,000	1165NRT	12.50	15.50	37.2	16.6	3,120
375,000	375MA/250MA/1150	10.25	18.00	41.0	18.7	6,000	3500S/3500R	13.44/10.25	20.0/18.06	38.0/41.0	14.0/18.75	5,050/6,000
376,100
416,667
506,300
519,000	1175NRT	13.50	17.50	43.6	17.4	4,800
540,000	540MA	15.25	21.00	47.0	22.5	9,000	5000R	15.25	21.00	47.0	22.5	9,000
700,000
720,000	720MA	15.25	21.00	47.0	23.5	10,000	5000S	13.44	20.00	38.0	14.8	5,930
747,000	1185NRT	15.50	20.00	50.0	18.0	6,625	5500R	15.25	21.00	47.00	23.5	10,000

★ All have Nitrile Seals up to 225°.

Backstop Selection Procedure Definitions

Application Terms

**Brake hp (BHP)
Brake kW (BkW)**

The calculated load required to operate the equipment. For conveyors, brake hp (kW) is based on the horsepower (kilowatts) required to overcome friction, and the horsepower (kilowatts) required to lift the load vertically.

Drive Pulley

A pulley mounted on the headshaft which supplies power to move conveyor belt.

**Lift hp (LHP)
Lift kW(LkW)**

Horsepower (kilowatts) required to lift the load vertically.

**Motor hp (MHP)
Motor kW (MkW)**

Motor nameplate rating.

Motor Starting Torque

Torque that the motor is capable of supplying at zero rpm (rev./min.) for approximately 15 seconds in a design B motor or 6 seconds in a design C motor to start equipment. Also called locked rotor torque.

Motor Stall Torque

Torque required to stop motor rotor from operating and is generally caused by overload conditions.

Motor Breakdown Torque

Maximum torque the motor produces (at about 75% of speed).

Drive Pulley hp (kW)

Horsepower (kilowatts) supplied to drive pulley.

Single Pulley Drive

One drive pulley provides all power to conveyor.

Tandem Motor Drive

Two motors driving one drive pulley drive.

Tandem Pulley Drive

Two pulleys are used to power conveyor, but are driven by one motor through a dual output drive arrangement. This is not commonly used today.

Dual Pulley Drive

Two pulleys are used to power conveyor and each pulley is driven by a separate motor(s).

Headshaft

Shaft on which drive pulley is mounted.

Indexing

Continuous cyclic or periodic applications of the backstop as encountered in the conversion of reciprocating or oscillating motion into intermittent linear motion.

Jogging

Stop/start movement with jerking or jolting motion.

Backstop Terms

Backstop Rating

Catalog torque rating.

Backstop load

Load applied to the backstop.

Backstop operation

Engagement of backstop rollers and outer race.

Tandem Backstops

Two backstops on the same drive pulley.

Dual Backstops

Two backstops on the same conveyor, but each on separate drive pulley.

Rexnord Tests Every Falk NRT Before Shipment

TRUE HOLD Low Speed Backstops are Full-Load Tested for Faultless Performance!!



REXNORD
PRECISION. POWER. PERFORMANCE.

Falk – A Rexnord Industries, LLC Company
NRT Backstop Test Report

Backstop Size _____ M.O. Number _____

Full – Load Tests

Cold Temperature
At each of 8 separate rotational positions, 45 degrees apart, the backstop was subjected to full-load reversals and functioned properly.

Hot Temperature
After spin test completion and attaining the temperature rise listed above, 8 full-load reversals were applied, as stated above, and the backstop functioned properly.

Spin Testing
After full-load testing in the "Cold" condition, the backstop listed above was run in the over-running direction for 30 minutes and the following performance parameters were evaluated:

_____ Test Speed
_____ Operating Temperature Rise
_____ Seal Functioning
_____ Noise Check
_____ Drag Torque

Falk certifies that this backstop, sold to _____ has successfully passed

And shipped to _____
full-load test _____ lb-ft.
Test Date _____ Testing Technician _____

Test protocol calls for full rating load tests and full maximum rating speed test on each NRT.

Test certificates available upon request.

NRT INDUSTRY APPLICATIONS



AGGREGATE

NRT mounted on headshaft on Primary Crusher Out-feed conveyor from quarry to stockpile



CEMENT

NRT on headshaft of Clinker Bucket Elevator



COAL

NRT headshaft mounted on clean coal stockpile belt conveyor



COAL

NRT (one of two units) reducer LS shaft mounted on triple 1000kW drift conveyor handling coal



COPPER

NRT headshaft mounted on secondary crusher out-feed conveyor



COPPER

NRT headshaft mounted on plant in-feed conveyor

REXNORD OFFERS ACCESSORIES TO MEET YOUR NEEDS

RETAINING COLLARS



SHAFT GUARDS



KEEPER PLATE ASSEMBLIES



AIRMAX BREATHERS



World Class Customer Service

For more than 100 years, the dedicated people of Rexnord have delivered excellence in quality and service to our customers around the globe. Rexnord is a trusted name when it comes to providing skillfully engineered products that improve productivity and efficiency for industrial applications worldwide. We are committed to exceeding customer expectations in every area of our business: product design, application engineering, operations, and customer service.

Because of our customer focus, we are able to thoroughly understand the needs of your business and have the resources available to work closely with you to reduce maintenance costs, eliminate redundant inventories and prevent equipment down time.

Rexnord represents the most comprehensive portfolio of power transmission and conveying components in the world with the brands you know and trust.

AirMax, TRUE HOLD, and Rexnord are registered trademarks of Rexnord Industries, LLC. Falk is a trademark of Rexnord. All rights reserved.

WORLDWIDE CUSTOMER SERVICE

AUSTRALIA

Rexnord Australia Pty. Ltd.
Picton, New South Wales
Phone: 61-2-4677-3811
Fax: 61-2-4677-3812

Falk-Rexnord Australia Pty Ltd
Broadmeadow New South Wales
Phone: 61-2-4962-8000
Fax: 61-2-4962-8001

BRAZIL

Rexnord Correntes Ltda.
Sao Leopoldo - RS
Phone: 55-51-579-8022
Fax: 55-51-579-8029

CANADA

Rexnord Canada Ltd.
Scarborough, Ontario
Phone: 1-416-297-6868
Fax: 1-416-297-6873

CHINA

Rexnord China
Shanghai, China
Phone: 86-21-62701942
Fax: 86-21-62701943

EUROPE

Rexnord NV/SA
Mechelen, Belgium
Phone: 32-15-443881
Fax: 32-15-443860

LATIN AMERICA

Rexnord International
Milwaukee, Wisconsin
Phone: 1-414-643-2366
Fax: 1-414-643-3222
E-mail: international1@rexnord.com

MEXICO

Rexnord S. A. de C. V.
Mexico DF, Mexico
Phone: 52-55-9140-3500
Fax: 52-55-9140-3550

SINGAPORE

Rexnord International, Inc.
Singapore City, Singapore
Phone: 65-6338-5622
Fax: 65-6338-5422

UNITED STATES

Customer Service
Phone: 866-Rexnord
(866-739-6673)
E-mail: rexnordcs(state)@rexnord.com
Example: rexnordcsohio@rexnord.com

ALL COUNTRIES NOT LISTED ABOVE

Rexnord International
Milwaukee, Wisconsin
Phone: 1-414-643-2366
Fax: 1-414-643-3222
E-mail: international2@rexnord.com

