



# SPARC Enterprise™ T5120 and T5220 Servers Product Notes

---

Copyright 2010 Sun Microsystems, Inc., 4150 Network Circle, Santa Clara, California 95054, U.S.A. and FUJITSU LIMITED, 1-1, Kamikodanaka 4-chome, Nakahara-ku, Kawasaki-shi, Kanagawa-ken 211-8588, Japan. All rights reserved.

Sun Microsystems, Inc. and Fujitsu Limited each own or control intellectual property rights relating to products and technology described in this document, and such products, technology and this document are protected by copyright laws, patents and other intellectual property laws and international treaties. The intellectual property rights of Sun Microsystems, Inc. and Fujitsu Limited in such products, technology and this document include, without limitation, one or more of the United States patents listed at <http://www.sun.com/patents> and one or more additional patents or patent applications in the United States or other countries.

This document and the product and technology to which it pertains are distributed under licenses restricting their use, copying, distribution, and decompilation. No part of such product or technology, or of this document, may be reproduced in any form by any means without prior written authorization of Fujitsu Limited and Sun Microsystems, Inc., and their applicable licensors, if any. The furnishing of this document to you does not give you any rights or licenses, express or implied, with respect to the product or technology to which it pertains, and this document does not contain or represent any commitment of any kind on the part of Fujitsu Limited or Sun Microsystems, Inc., or any affiliate of either of them.

This document and the product and technology described in this document may incorporate third-party intellectual property copyrighted by and/or licensed from suppliers to Fujitsu Limited and/or Sun Microsystems, Inc., including software and font technology.

Per the terms of the GPL or LGPL, a copy of the source code governed by the GPL or LGPL, as applicable, is available upon request by the End User. Please contact Fujitsu Limited or Sun Microsystems, Inc.

This distribution may include materials developed by third parties.

Parts of the product may be derived from Berkeley BSD systems, licensed from the University of California. UNIX is a registered trademark in the U.S. and in other countries, exclusively licensed through X/Open Company, Ltd.

Sun, Sun Microsystems, the Sun logo, Java, Netra, Solaris, Sun Ray, AnswerBook2, docs.sun.com, OpenBoot, and Sun Fire are trademarks or registered trademarks of Sun Microsystems, Inc., or its subsidiaries, in the U.S. and other countries.

Fujitsu and the Fujitsu logo are registered trademarks of Fujitsu Limited.

All SPARC trademarks are used under license and are registered trademarks of SPARC International, Inc. in the U.S. and other countries. Products bearing SPARC trademarks are based upon architecture developed by Sun Microsystems, Inc.

SPARC64 is a trademark of SPARC International, Inc., used under license by Fujitsu Microelectronics, Inc. and Fujitsu Limited.

The OPEN LOOK and Sun™ Graphical User Interface was developed by Sun Microsystems, Inc. for its users and licensees. Sun acknowledges the pioneering efforts of Xerox in researching and developing the concept of visual or graphical user interfaces for the computer industry. Sun holds a non-exclusive license from Xerox to the Xerox Graphical User Interface, which license also covers Sun's licensees who implement OPEN LOOK GUIs and otherwise comply with Sun's written license agreements.

United States Government Rights - Commercial use. U.S. Government users are subject to the standard government user license agreements of Sun Microsystems, Inc. and Fujitsu Limited and the applicable provisions of the FAR and its supplements.

Disclaimer: The only warranties granted by Fujitsu Limited, Sun Microsystems, Inc. or any affiliate of either of them in connection with this document or any product or technology described herein are those expressly set forth in the license agreement pursuant to which the product or technology is provided. EXCEPT AS EXPRESSLY SET FORTH IN SUCH AGREEMENT, FUJITSU LIMITED, SUN MICROSYSTEMS, INC. AND THEIR AFFILIATES MAKE NO REPRESENTATIONS OR WARRANTIES OF ANY KIND (EXPRESS OR IMPLIED) REGARDING SUCH PRODUCT OR TECHNOLOGY OR THIS DOCUMENT, WHICH ARE ALL PROVIDED AS IS, AND ALL EXPRESS OR IMPLIED CONDITIONS, REPRESENTATIONS AND WARRANTIES, INCLUDING WITHOUT LIMITATION ANY IMPLIED WARRANTY OF MERCHANTABILITY, FITNESS FOR A PARTICULAR PURPOSE OR NON-INFRINGEMENT, ARE DISCLAIMED, EXCEPT TO THE EXTENT THAT SUCH DISCLAIMERS ARE HELD TO BE LEGALLY INVALID. Unless otherwise expressly set forth in such agreement, to the extent allowed by applicable law, in no event shall Fujitsu Limited, Sun Microsystems, Inc. or any of their affiliates have any liability to any third party under any legal theory for any loss of revenues or profits, loss of use or data, or business interruptions, or for any indirect, special, incidental or consequential damages, even if advised of the possibility of such damages.

DOCUMENTATION IS PROVIDED "AS IS" AND ALL EXPRESS OR IMPLIED CONDITIONS, REPRESENTATIONS AND WARRANTIES, INCLUDING ANY IMPLIED WARRANTY OF MERCHANTABILITY, FITNESS FOR A PARTICULAR PURPOSE OR NON-INFRINGEMENT, ARE DISCLAIMED, EXCEPT TO THE EXTENT THAT SUCH DISCLAIMERS ARE HELD TO BE LEGALLY INVALID.



Copyright 2010 Sun Microsystems, Inc., 4150 Network Circle, Santa Clara, California 95054, U.S.A. et FUJITSU LIMITED, 1-1, Kamikodanaka 4-chome, Nakahara-ku, Kawasaki-shi, Kanagawa-ken 211-8588, Japon. Tous droits réservés.

Entrée et revue tecnica fournies par Fujitsu Limited sur des parties de ce matériel.

Sun Microsystems, Inc. et Fujitsu Limited détiennent et contrôlent toutes deux des droits de propriété intellectuelle relatifs aux produits et technologies décrits dans ce document. De même, ces produits, technologies et ce document sont protégés par des lois sur le copyright, des brevets, d'autres lois sur la propriété intellectuelle et des traités internationaux. Les droits de propriété intellectuelle de Sun Microsystems, Inc. et Fujitsu Limited concernant ces produits, ces technologies et ce document comprennent, sans que cette liste soit exhaustive, un ou plusieurs des brevets déposés aux États-Unis et indiqués à l'adresse <http://www.sun.com/patents> de même qu'un ou plusieurs brevets ou applications brevetées supplémentaires aux États-Unis et dans d'autres pays.

Ce document, le produit et les technologies afférents sont exclusivement distribués avec des licences qui en restreignent l'utilisation, la copie, la distribution et la décompilation. Aucune partie de ce produit, de ces technologies ou de ce document ne peut être reproduite sous quelque forme que ce soit, par quelque moyen que ce soit, sans l'autorisation écrite préalable de Fujitsu Limited et de Sun Microsystems, Inc., et de leurs éventuels bailleurs de licence. Ce document, bien qu'il vous ait été fourni, ne vous confère aucun droit et aucune licence, expresses ou tacites, concernant le produit ou la technologie auxquels il se rapporte. Par ailleurs, il ne contient ni ne représente aucun engagement, de quelque type que ce soit, de la part de Fujitsu Limited ou de Sun Microsystems, Inc., ou des sociétés affiliées.

Ce document, et le produit et les technologies qu'il décrit, peuvent inclure des droits de propriété intellectuelle de parties tierces protégés par copyright et/ou cédés sous licence par des fournisseurs à Fujitsu Limited et/ou Sun Microsystems, Inc., y compris des logiciels et des technologies relatives aux polices de caractères.

Par limites du GPL ou du LGPL, une copie du code source régi par le GPL ou LGPL, comme applicable, est sur demande vers la fin utilisateur disponible; veuillez contacter Fujitsu Limited ou Sun Microsystems, Inc.

Cette distribution peut comprendre des composants développés par des tierces parties.

Des parties de ce produit pourront être dérivées des systèmes Berkeley BSD licenciés par l'Université de Californie. UNIX est une marque déposée aux États-Unis et dans d'autres pays et dans d'autres pays et licenciée exclusivement par X/Open Company, Ltd.

Sun, Sun Microsystems, le logo Sun, Java, Netra, Solaris, Sun Ray, Answerbook2, docs.sun.com, OpenBoot, et Sun Fire sont des marques de fabrique ou des marques déposées de Sun Microsystems, Inc., ou ses filiales, aux États-Unis et dans d'autres pays.

Fujitsu et le logo Fujitsu sont des marques déposées de Fujitsu Limited.

Toutes les marques SPARC sont utilisées sous licence et sont des marques de fabrique ou des marques déposées de SPARC International, Inc. aux États-Unis et dans d'autres pays. Les produits portant les marques SPARC sont basés sur une architecture développée par Sun Microsystems, Inc.

SPARC64 est une marques déposée de SPARC International, Inc., utilisée sous le permis par Fujitsu Microelectronics, Inc. et Fujitsu Limited.

L'interface d'utilisation graphique OPEN LOOK et Sun™ a été développée par Sun Microsystems, Inc. pour ses utilisateurs et licenciés. Sun reconnaît les efforts de pionniers de Xerox pour la recherche et le développement du concept des interfaces d'utilisation visuelle ou graphique pour l'industrie de l'informatique. Sun détient une licence non exclusive de Xerox sur l'interface d'utilisation graphique Xerox, cette licence couvrant également les licenciés de Sun qui mettent en place l'interface d'utilisation graphique OPEN LOOK et qui, en outre, se conforment aux licences écrites de Sun.

Droits du gouvernement américain - logiciel commercial. Les utilisateurs du gouvernement américain sont soumis aux contrats de licence standard de Sun Microsystems, Inc. et de Fujitsu Limited ainsi qu'aux clauses applicables stipulées dans le FAR et ses suppléments.

Avis de non-responsabilité: les seules garanties octroyées par Fujitsu Limited, Sun Microsystems, Inc. ou toute société affiliée de l'une ou l'autre entité en rapport avec ce document ou tout produit ou toute technologie décrit(e) dans les présentes correspondent aux garanties expressément stipulées dans le contrat de licence régissant le produit ou la technologie fourni(e). SAUF MENTION CONTRAIRE EXPRESSÉMENT STIPULÉE DANS CE CONTRAT, FUJITSU LIMITED, SUN MICROSYSTEMS, INC. ET LES SOCIÉTÉS AFFILIÉES REJETTENT TOUTE REPRÉSENTATION OU TOUTE GARANTIE, QUELLE QU'EN SOIT LA NATURE (EXPRESSE OU IMPLICITE) CONCERNANT CE PRODUIT, CETTE TECHNOLOGIE OU CE DOCUMENT, LESQUELS SONT FOURNIS EN L'ÉTAT. EN OUTRE, TOUTES LES CONDITIONS, REPRÉSENTATIONS ET GARANTIES EXPRESSES OU TACITES, Y COMPRIS NOTAMMENT TOUTE GARANTIE IMPLICITE RELATIVE À LA QUALITÉ MARCHANDE, À L'APTITUDE À UNE UTILISATION PARTICULIÈRE OU À L'ABSENCE DE CONTREFAÇON, SONT EXCLUES, DANS LA MESURE AUTORISÉE PAR LA LOI APPLICABLE. Sauf mention contraire expressément stipulée dans ce contrat, dans la mesure autorisée par la loi applicable, en aucun cas Fujitsu Limited, Sun Microsystems, Inc. ou l'une de leurs filiales ne sauraient être tenues responsables envers une quelconque partie tierce, sous quelque théorie juridique que ce soit, de tout manque à gagner ou de perte de profit, de problèmes d'utilisation ou de perte de données, ou d'interruptions d'activités, ou de tout dommage indirect, spécial, secondaire ou consécutif, même si ces entités ont été préalablement informées d'une telle éventualité.

LA DOCUMENTATION EST FOURNIE "EN L'ÉTAT" ET TOUTES AUTRES CONDITIONS, DECLARATIONS ET GARANTIES EXPRESSES OU TACITES SONT FORMELLEMENT EXCLUES, DANS LA MESURE AUTORISÉE PAR LA LOI APPLICABLE, Y COMPRIS NOTAMMENT TOUTE GARANTIE IMPLICITE RELATIVE A LA QUALITE MARCHANDE, A L'APTITUDE A UNE UTILISATION PARTICULIERE OU A L'ABSENCE DE CONTREFAÇON.



# Contents

---

<b>Preface</b>	<b>xi</b>
<b>1. New Information About the SPARC Enterprise T5120 and T5220 Servers</b>	<b>1</b>
New Information About Known Issues	1
Firmware, ILOM, POST, and SP Issues	2
After the Power Cord Removal/Insert, an Error Message May Appear during the POST	2
Solaris OS Issues	4
Boot Drive May Report “drive type unknown” for Solaris format Command (CR 6886514)	4
New Information About Documentation Errata	12
<i>Integrated Lights Out Manager (ILOM) 3.0 CLI Procedures Guide</i>	12
Erroneous Description about Collecting SP Data	12
<i>Integrated Lights Out Manager 3.0 Web Interface Procedures Guide</i>	12
Erroneous Description about Collecting SP Data	12
<b>2. Important Information About the SPARC Enterprise T5120 and T5220 Servers</b>	<b>15</b>
Notes on DVD Drive and Discs	15
Supported Versions of the OS and Firmware	16
Solaris OS and Firmware Requirements for Certain Features	17
System Firmware	17

Preinstalled Software	18
Solaris 10 OS and Solaris Live Upgrade	19
Additional Software Available for Your Server – Cool Tools	19
Logical Domains	20
Supported Sun Explorer Utility Version	20
Sun Studio C, C++ & Fortran Compilers and Tools	21
Mandatory Patch Information	22
Mandatory Patches for the Solaris 10 8/07 OS	22
Mandatory Patches for the Solaris 10 5/08 OS	22
Mandatory Patches for the Solaris 10 10/08 OS	23
Mandatory Patches for the Solaris 10 5/09 OS	23
▼ To Download Patches	23
Patches for Option Cards	23
Installing the 4Gbps Fibre Channel card	24
General Functionality Issues and Limitations	24
Cryptographic Function	24
RAID Function	24
Cable Management Arm	25
Express Rail Rackmounting Kit	25
SSD (Solid State Drive)	25
SAS RAID Internal HBA Card	25
Processor Identification	25
Notes on the Use of 200V Power Supply	26
<b>3. Known Issues</b>	<b>27</b>
Hardware and Mechanical Issues	28
Ethernet Interface Related Issues	31
Temporary PCIe Link Failure During Boot Causes a Fatal Error Later (CR 6553515)	31

Errors Are Generated When 100Mb/Full With Forced Speed/Duplex Is Set in e1000g.conf (CR 6555486)	32
Firmware, ILOM, POST, and SP Issues	33
Problem When the PCIe Link Fails to Train as x8 (CR 6556505)	43
▼ To Identify the Problem	44
▼ To Correct the Problem	44
Communication Channel Between the Primary Domain and the Service Processor (SP) Might Hang (CR 6583567)	45
▼ To Recover From a Domain Crash	45
Resetting the SP Produces Extraneous Warning Messages (CR 6585292)	46
Error Messages from the Ultra320 SCSI Card	47
Erroneous Power Supply Faults (CR 6614432)	47
A Built-In Fan May be Erroneously Detected as a Failure (CR 6636098)	48
After a Host Power-On Instruction is Executed from ILOM, the POST May Not Start, and Processing May Not Go to OS Boot Processing or the ok Prompt (CR 6752910)	49
For DC Input Power Models, /PS0/AC_POK Is Displayed (CR 6815369)	50
According to the IPMI PET Warning and SNMP Trap Warning Settings in the Warning Rule Settings, Warning Message Creation may not be Possible Depending on the Event Type (CR 6746677)	51
In the Logical Domains Environment, After the Host Reset Operation, Host May Be Reset Again (CR 6836426)	52
The ILOM Network Configuration Cannot Be Set (CR 6835854, 6779753)	53
An Error is Registered with the showfaults Command When Running POST, But POST Ends Normally (CR 11210193)	54
The ok Prompt is Not Displayed After POST Ends (CR 11215994)	55
Solaris OS Issues	56
Sun Explorer May Fail to Collect the ILOM Data (Tx000) (CR 6718841)	59
Notes on Installing Solaris 10 8/07 OS and Solaris 10 5/08 OS	60
LDoms Related Issues	62

#### 4. Documentation Errata 63

- SPARC Enterprise T5120 and T5220 Servers Site Planning Guide* 63
  - Error on page 2 in "Minimum Clearance for Service Access" 63
  - Incorrect Values for the 1.6 GHz SpecJBB Test 66
  - Incorrect Idle Input Power Values 67
- SPARC Enterprise T5120 and T5220 Servers Installation Guide* 68
  - Verify Proper Seating of Preinstalled PCIe/XAUI Cards 68
- SPARC Enterprise T5120 and T5220 Servers Service Manual* 68
  - Erroneous Description in the Section "Disconnect Power Cords From the Server" 68
  - Erroneous Description in the Section "Removing the Air Duct" on page 101 69
  - Erroneous Description in "Fan Module Configurations for SPARC Enterprise T5220 Servers (8- and 16-Disk Capable)" 70
  - Unnecessary Procedure in "Install the Hard Drive Cage" 70
  - Incorrect FRU Name is Specified in the TABLE: Motherboard Components (SPARC Enterprise T5120 Servers) 70
  - Incorrect FRU Name is Specified in the TABLE: Motherboard Components (SPARC Enterprise T5220 Servers) 71
- SPARC Enterprise T5120 and T5220 Servers Administration Guide* 71
  - Notes on the "SPARC Enterprise T5x20 Device Tree" 71
- Integrated Lights Out Manager 2.0 User's Guide* 71
  - Incorrect ILOM Command Related to IP Address Assignment 71
  - The Command in the Section "Edit an SNMP User Account Using the CLI" on Page 195 is Incorrect 72
- Integrated Lights Out Manager 2.0 Supplement for the SPARC Enterprise T5120 and T5220 Servers* 72
  - Points of Concern about the Connection of ILOM (CR 6806789) 72
  - About ALOM CMT Shell Command 72
- Integrated Lights Out Manager (ILOM) 3.0 CLI Procedures Guide* 73



	Erroneous Description in "Collect SP Data to Diagnose System Problems" (CR 6806800)	73
	Erroneous Default Value for /SP/clients/dns	73
	<i>Integrated Lights Out Manager 3.0 Supplement for SPARC Enterprise T5120 and T5220 Servers</i>	74
	Notes on "ILOM Information Stored on the SCC"	74
<b>A.</b>	<b>Fixed Issues</b>	<b>75</b>
	Hardware and Mechanical Issues	75
	L2 Cache Errors Might Generate an Erroneous Memory Fault (CR 6592272)	76
	Ethernet Interface Related Issues	77
	Using modunload While the nxge Port Is Running, Could Cause a System Panic (CR 6551509)	78
	▼ To Unplumb the Interfaces Prior to Unloading the Driver	79
	Jumbo Frames Throughput of nxge Drops to 30 Mbps Due to Packet Dropping (CR 6554478)	80
	▼ To Set the MTU Size to 8172	81
	Setting Properties for nxge Devices Might Fail (CR 6561389)	82
	Server Might Panic in nxge_start When dupb Fails (CR 6567838)	82
	▼ To Disable Jumbo Frames	82
	▼ To Set the MTU to a Smaller Size	83
	Firmware, ILOM, POST, and SP Issues	84
	SP Serial Line Terminal Server break Command Does Not Work (CR 6577528)	100
	The showfaults Command Shows the Motherboard as Faulty Instead of the DIMM (CR 6582853)	101
	The uadmin 2 0 and reboot Commands Read Old Bootmode Settings (CR 6585340)	102
	Domain ETM and LDC Deadlock When Transmit Queue Full (CR 6594506)	103
	Spurious PIU Errors (CR 6598381)	106

Diagnostic Routine That Runs at Startup (IBIST) Might Accidentally Disconnect the MCU (CR 6618773)	107
MCU Might Be Disconnected in DIMM Module Failure (CR 6656116)	108
When the <code>showenvironment</code> Command is Executed in a Sixteen-Disk Capable Server, Even Though the Hard Disk is Mounted in Slot #8, "NOT PRESENT" is Output. (CR 6772707)	109
For DC Input Power Models, the Output From the <code>showpower -v</code> Command May Differ Between <code>/SYS/PS0</code> And <code>/SYS/PS1</code> (CR 6802433)	111
In the Output From the <code>prtdiag</code> Command, Warnings May Be Displayed (CR 6821325)	112
During the Power-On Self-Test, the Diagnostic Process May Terminate Halfway (CR 6835860)	113
On the DC Input Power Model, the "Environmental Status" and Some Part of the "FRU Status" Information Is Not Displayed (CR 6853843)	114
When the Service Processor Is Initialized, ILOM May Fail to Start With an Error Message Displayed (CR 6856163)	115
After the SCC Module Replacement, a Connection to the ILOM Network May Fail (CR 6857271)	117
Solaris OS Issues	118
Servers Might Experience Panics Generated From the PCIe Root Complex (CR 6555956)	122
Information Missing From <code>prtpicl</code> and <code>prtdiag</code> Commands (CR 6586624)	123
Booting the Solaris OS From an External USB DVD-ROM Drive Could Cause a Panic (CR 6588452)	124
The <code>prtdiag -v</code> Command Has Formatting Issues (CR 6587389)	125
PSH Events Are no Longer Transported (CR 6594506)	125
LDOms Related Issues	128

# Preface

---

These product notes contain late-breaking information about the SPARC Enterprise™ T5120 and T5220 servers hardware, software, or documentation errata that became known after the documentation set was published.

- [“Support for the SPARC Enterprise T5120 and T5220 Servers” on page xi](#)
- [“Fujitsu Welcomes Your Comments” on page xii](#)

---

## Support for the SPARC Enterprise T5120 and T5220 Servers

### Technical Support

If you have any technical questions or issues that are not addressed in the SPARC Enterprise T5120 or T5220 servers documentation, contact a sales representative or a certified service engineer.

### Downloading Documentation

Instructions for installing, administering, and using your servers are provided in the SPARC Enterprise T5120 and T5220 servers documentation sets. The entire documentation set is available for download from the following web site:

Global Site

<http://www.fujitsu.com/sparcenterprise/manual/>

North American Site

<https://download.computers.us.fujitsu.com/>

Japanese Site

<http://primeserver.fujitsu.com/sparcenterprise/manual/>

---

**Note** – Information in these product notes supersedes the information in the SPARC Enterprise T5120 and T5220 documentation sets.

---

## Fujitsu Welcomes Your Comments

If you have any comments or requests regarding this document, or if you find any unclear statements in the document, please state your points specifically on the form at the following URL.

For Users in U.S.A., Canada, and Mexico:

[http://www.computers.us.fujitsu.com/www/support\\_servers.shtml?support/servers](http://www.computers.us.fujitsu.com/www/support_servers.shtml?support/servers)

For Users in Other Countries:

SPARC Enterprise contact

[http://www.fujitsu.com/global/contact/computing/sparce\\_index.html](http://www.fujitsu.com/global/contact/computing/sparce_index.html)

# New Information About the SPARC Enterprise T5120 and T5220 Servers

---

This chapter describes new information about the SPARC Enterprise™ T5120 and T5220 servers that was not documented in the previous edition of the *SPARC Enterprise T5120 and T5220 Servers Product Notes*.

The following sections are included in this chapter:

- [“New Information About Known Issues” on page 1](#)-- This section describes technical issues that were identified after the previous edition was published.
- [“New Information About Documentation Errata” on page 12](#)-- This section describes documentation errors that were identified after the previous edition was published.

Information that was documented in the previous edition of this document is provided in the following locations:

- [Chapter 2](#) contains important information about the T5120 and T5220 servers.
  - [Chapter 3](#) describes technical issues.
  - [Chapter 4](#) describes documentation issues.
- 

## New Information About Known Issues

This section describes issues that were discovered since the previous edition of these product notes was published.

# Firmware, ILOM, POST, and SP Issues

**TABLE 1-1** Firmware, ILOM, POST, and SP Issues

CR	Description	Workaround
6722602 6663105	When connected to OS console via ILOM, input or display to console may not be enabled. And at this time, output from OS to console may fail.	<b>Note - Fixed in System Firmware 7.2.2.e or later.</b> After the system stop, disconnect the power cord and then reconnect the power cord.
6913388	The ILOM event log may not be in the Solaris OS system log output (/var/adm/messages). ILOM login event example: Nov 7 14:13:03 xxxxxx SC Alert: [ID 178418 daemon.notice] Audit   minor: admin : Open Session : object = /session/type : value = shell : success Nov 7 14:13:04 xxxxxx SC Alert: [ID 434268 daemon.notice] Audit   minor: admin : Close Session : object = /session/type : value = shell : success	None. Perform the ILOM reset operation. If not recovered, shut down the system and then remove and insert the power cord. ILOM reset operation example: Log in to ILOM and execute the following command. [In case of ILOM command mode] -> reset /SP Are you sure you want to reset /SP (y/n)? y [In case of ALOM CMT compatible shell] sc> resetsc Are you sure you want to reset the SC [y/n]? y
n/a	After you remove/insert the power cord and while POST is running, the “/SYS/XXXXX prom is unreadable or corrupted” message may appear and stop at ok prompt. For details, see <a href="#">“After the Power Cord Removal/Insert, an Error Message May Appear during the POST” on page 2.</a>	Take 180 or more seconds for each of the intervals between the system power-off and the power cord removal, and between the removal and insertion of the power cord.

## After the Power Cord Removal/Insert, an Error Message May Appear during the POST

After you remove/insert the power cord and while POST is running, the “/SYS/XXXXX prom is unreadable or corrupted” message may appear and stop at ok prompt.

### Message example:

```
Chassis | major: Host has been powered on
0:0:0>
0:0:0>SPARC-Enterprise[™] T5120/T5220 POST 4.30.6 2009/12/01 13:08

/export/delivery/delivery/4.30/4.30.6/post4.30.6-micro/Niagara/huron/integrated
(root)
0:0:0>Copyright 2009 Sun Microsystems, Inc. All rights reserved
0:0:0>POST enabling CMP 0 threads: ffffffff.fffffff
0:0:0>VBSC mode is: 00000000.00000001
0:0:0>VBSC level is: 00000000.00000001
0:0:0>VBSC selecting Normal mode, MAX Testing.
0:0:0>VBSC setting verbosity level 2
0:0:0>Basic Memory Tests....Done
0:0:0>Test Memory....Done
0:0:0>Setup POST Mailbox ....Done
0:0:0>Master CPU Tests Basic....Done
0:0:0>Init MMU.....
Fault | critical: SP detected fault at time Mon Jan 18 08:45:10 2010. /SYS/PADCRD
prom is unreadable or corrupted
0:0:0>NCU Setup and PIU link train....Done
0:0:0>L2 Tests....Done
0:0:0>Extended CPU Tests....Done
0:0:0>Scrub Memory....Done
0:0:0>SPU CWQ Tests...Done
0:0:0>MAU Tests...Done
0:0:0>Network Interface Unit Tests....Done
0:0:0>Functional CPU Tests....Done
0:0:0>Extended Memory Tests....Done
2010-01-18 08:46:50.299 0:0:0>INFO:
2010-01-18 08:46:50.302 0:0:0> POST Passed all devices.
2010-01-18 08:46:50.307 0:0:0>POST:      Return to VBSC.
2010-01-18 08:46:50.310 0:0:0>Master set ACK for vbsc runpost command and spin...
Chassis | major: Host is running

SPARC Enterprise T5220, No Keyboard
Copyright 2009 Sun Microsystems, Inc. All rights reserved.
OpenBoot 4.30.6, 8064 MB memory available, Serial #85367270.
Ethernet address 0:21:28:16:99:e6, Host ID: 851699e6.

{0} ok
```

This event occurs in case you power off the system and remove the power cord in a short period of time, or in case you remove and insert the power cord in a short period of time. When the above time period is too short, the ILOM internal process does not complete normally.

When this event occurred, perform the following procedure. After you restored using this procedure, you do not need to replace the component.

**1. Turn off the power to the system.**

- Power-off operation example -

[In case of ALOM CMT compatible shell]

```
sc> poweroff -y
```

[In case of ILOM mode]

```
-> stop -script /SYS
```

**2. Wait for 180 or more seconds.**

**3. Remove the power cord.**

**4. Wait for 180 or more seconds.**

**5. Insert the power cord.**

Workaround: Take 180 or more seconds for each of the intervals between the system power-off and the power cord removal, and between the removal and insertion of the power cord.

## Solaris OS Issues

### Boot Drive May Report “drive type unknown” for Solaris format Command (CR 6886514)

This issue is resolved with Solaris patch ID 124630-32 or later.

During a period extending from mid-September to early October 2009 (approximately 3 weeks) a patch was preinstalled on some SPARC Enterprise T5120 and T5220 servers, which introduced a latent bug into those systems. The bug is described as “latent” because it is activated only when the Solaris format command is used. Otherwise, the bug has no effect on system behavior or performance.

When a system administrator or other user with root (/) privileges enters the format command on a system containing this bug, the boot drive will report “drive type unknown”. This fault condition presents two problems for the administrator:

- The administrator will be unable to access unused portions of the boot drive because of the unknown drive type error.
- The presence of mounted partitions blocks use of the format utility’s auto configure feature. Attempts to bypass this restriction by booting from the network or removable media could put the system in an unbootable state.



The Workaround section below describes a procedure you can use to recover from this “drive type unknown” fault mode without the risks associated with the network and media boot methods.

Workaround: The sequence of steps shown in CODE EXAMPLE 1 must be followed exactly as shown. To simplify tracking of the procedure, the steps are organized into nine sections:

1. **Determine whether or not the system’s boot device is affected.**
2. **Shut server down and restart in single user mode with the root filesystem mounted read only.**
3. **Mount the `tmpfs` /`tmp` filesystem to provide a working area.**
4. **Capture the boot drive’s existing `vtoc` in a file stored in /`tmp`.**
5. **Make a copy of the `fmthard` utility for use in the /`tmp` work area.**
6. **Set and export the `NOINUSE_CHECK` variable to allow the `format` command full access to the boot drive.**
7. **Run the `format` utility to restore the drive’s “type”.**
8. **Use the `fmthard` command and stored information to complete the recovery.**
9. **Verify the success of the recovery.**

**CODE EXAMPLE 1-1** Procedure for Recovering a Boot Drive’s “drive type”

1. Determine if the boot drive is affected:

```
root@host-1 # uname -a
SunOS host-1 5.10 Generic_141414-10 sun4v sparc SUNW,SPARC-Enterprise-T5220
root@host-1 # mount -p | head -1
/dev/dsk/c0t0d0s0 - / ufs - no rw,intr,largefiles,logging,xattr,onerror=
panic
root@host-1 # format c0t0d0s0 <===== boot device determined previously
/dev/dsk/c0t0d0s0 is currently mounted on /. Please see umount(1M).
/dev/dsk/c0t0d0s1 is currently used by swap. Please see swap(1M).

FORMAT MENU:
disk      - select a disk
type      - select (define) a disk type
partition - select (define) a partition table
```

**CODE EXAMPLE 1-1** Procedure for Recovering a Boot Drive's "drive type"

```
format - format and analyze the disk
repair - repair a defective sector
label - write label to the disk
analyze - surface analysis
defect - defect list management
backup - search for backup labels
verify - read and display labels
save - save new disk/partition definitions
inquiry - show vendor, product and revision
volname - set 8-character volume name The jumpstart install process
!cmd> - execute <cmd>, then return
quit
format> disk
```

The jumpstart install process

AVAILABLE DISK SELECTIONS:

```
0. c0t0d0 <drive type unknown> <===== problem indication
   /pci@0/pci@0/pci@2/scsi@0/sd@0,0
```

Specify disk (enter its number)[0]: **^C** <===== quit with <ctrl>C

```
format> quit
```

```
root@host-1 #
```

2. Shut the server down; then bring it up in single user mode with root filesystem mounted read only.

```
root@host-1 # init 0
```

```
Oct 20 16:26:56 host-1 syslogd: going down on signal 15
```

```
svc.startd: The system is down.
```

```
syncing file systems... done
```

```
Program terminated
```

```
SPARC Enterprise T5220, No Keyboard
```

```
Copyright 2009 Sun Microsystems, Inc. All rights reserved.
```

```
OpenBoot 4.30.4, 3968 MB memory available, Serial #xxxxxxxx.
```

```
Ethernet address xx:xx:xx:xx:xx:xx, Host ID: xxxxxxxx.
```

```
{0} ok boot -m milestone=none
```

```
Boot device: /pci@0/pci@0/pci@2/scsi@0/disk@0,0:a File and args: -m
milestone=none
```

```
SunOS Release 5.10 Version Generic_141414-10 64-bit
```

```
Copyright 1983-2009 Sun Microsystems, Inc. All rights reserved.
```

```
Use is subject to license terms.
```

```
Booting to milestone "none".
```

**CODE EXAMPLE 1-1** Procedure for Recovering a Boot Drive's "drive type"

```
Requesting System Maintenance Mode
(See /lib/svc/share/README for more information.)
Console login service(s) cannot run

Root password for system maintenance (control-d to bypass): <===== login
single user mode
single-user privilege assigned to /dev/console.
Entering System Maintenance Mode

Oct 20 18:06:11 su: ' su root ' succeeded for root on /dev/console
Sun Microsystems Inc.SunOS 5.10GenericJanuary 2005
Sourcing ../profile-EIS.....
```

3. Mount the tmpfs /tmp filesystem to provide a working area.

```
root@ # mount -F tmpfs /tmp
root@ # cd /tmp
```

4. Capture the boot drive's existing vtoc in a file stored in /tmp. Use the raw device of the boot device determined at the beginning -- i.e., use /dev/rdisk/c?t?d?s? not /dev/dsk/c?t?d?s?

```
root@ # prtvtoc /dev/rdisk/c0t0d0s0 > /tmp/vtoc <=====boot disk vtoc saved
in /tmp/vtoc
```

5. Make a copy of the fmthard utility for use in the /tmp work area.

```
root@ # cp /usr/sbin/fmthard /tmp
```

6. Set and export the NOINUSE\_CHECK variable:

```
root@ # setenv NOINUSE_CHECK=1
root@ # export NOINUSE_CHECK
```

7. Run the format utility to restore the drive's "type".

```
root@ # format
Searching for disks...done
```

AVAILABLE DISK SELECTIONS:

```
0. c0t0d0 <drive type unknown> <===== drive type unknown is the issue
/pci@0/pci@0/pci@2/scsi@0/sd@0,0
Specify disk (enter its number): 0
```

**CODE EXAMPLE 1-1** Procedure for Recovering a Boot Drive's "drive type"

```
Format will now present the following menu, choose 0. Auto configure
```

```
AVAILABLE DRIVE TYPES:
```

- 0. Auto configure
- 1. Quantum ProDrive 80S
- 2. Quantum ProDrive 105S
- [...]
- 17. Zip 250
- 18. Peerless 10GB
- 19. other

```
Specify disk type (enter its number): 0
```

```
c0t0d0: configured with capacity of 68.35GB <===== drive type corrected  
<SUN72G cyl 14087 alt 2 hd 24 sec 424> <===== drive type corrected  
selecting c0t0d0  
[disk formatted]
```

Following Auto configure, the correct drive value should be reported.

```
FORMAT MENU:
```

- disk - select a disk
- type - select (define) a disk type
- partition - select (define) a partition table
- current - describe the current disk
- format - format and analyze the disk
- repair - repair a defective sector
- label - write label to the disk
- analyze - surface analysis
- defect - defect list management
- backup - search for backup labels
- verify - read and display labels
- save - save new disk/partition definitions
- inquiry - show vendor, product and revision
- volname - set 8-character volume name The jumpstart install process
- !<cmd> - execute <cmd>, then return
- quit

```
format> label
```

```
Ready to label disk, continue? y
```

```
format> quit
```

```
root@ #
```

**CODE EXAMPLE 1-1** Procedure for Recovering a Boot Drive's "drive type"

8. Use the `fmthard` command and stored information to complete the recovery.

```
root@ # /tmp/fmthard -s /tmp/vtoc /dev/rdisk/c0t0d0s0 <=== raw boot device
      used to capture vtoc.
fmthard: New volume table of contents now in place.
root@ #
```

9. Verify the success of the recovery.

```
root@ # format
Searching for disks...done
```

AVAILABLE DISK SELECTIONS:

```
0. c0t0d0 <SUN72G cyl 14087 alt 2 hd 24 sec 424>
   /pci@0/pci@0/pci@2/scsi@0/sd@0,0
Specify disk (enter its number): 0
selecting c0t0d0
[disk formatted]
```

FORMAT MENU:

```
disk      - select a disk
type      - select (define) a disk type
partition - select (define) a partition table
current   - describe the current disk
format    - format and analyze the disk
repair    - repair a defective sector
label     - write label to the disk
analyze   - surface analysis
defect    - defect list management
backup    - search for backup labels
verify    - read and display labels
save      - save new disk/partition definitions
inquiry   - show vendor, product and revision
volname   - set 8-character volume name The jumpstart install process
!<cmd>    - execute <cmd>, then return
quit
```

```
format> partition
```

PARTITION MENU:

```
0      - change ' 0 ' partition
1      - change ' 1 ' partition
2      - change ' 2 ' partition
3      - change ' 3 ' partition
4      - change ' 4 ' partition
```

**CODE EXAMPLE 1-1** Procedure for Recovering a Boot Drive's "drive type"

```
5      - change ' 5 ' partition
6      - change ' 6 ' partition
7      - change ' 7 ' partition
select - select a predefined table
modify - modify a predefined partition table
name   - name the current table
print  - display the current table
label  - write partition map and label to the disk
!<cmd> - execute <cmd>, then return
quit

partition> print
Current partition table (original):
Total disk cylinders available: 14087 + 2 (reserved cylinders)

Part Tag      Flag  Cylinders      Size      Blocks
0  root       wm    825 - 3298    12.00GB  (2474/0/0)    25175424
1  swap       wu    0 - 824      4.00GB   (825/0/0)     8395200
2  backup     wm    0 - 14086    68.35GB  (14087/0/0)   143349312
3  unassigned wm    3299 - 5772  12.00GB  (2474/0/0)    25175424
4  unassigned wu    0           0         (0/0/0)       0
5  unassigned wu    0           0         (0/0/0)       0
6  unassigned wu    0           0         (0/0/0)       0
7  nassigned  wu    0           0         (0/0/0)       0

partition> quit

FORMAT MENU:
disk      - select a disk
type      - select (define) a disk type
partition - select (define) a partition table
current   - describe the current disk
format    - format and analyze the disk
repair    - repair a defective sector
label     - write label to the disk
analyze   - surface analysis
defect    - defect list management
backup    - search for backup labels
verify    - read and display labels
save      - save new disk/partition definitions
inquiry   - show vendor, product and revision
volname   - set 8-character volume name The jumpstart install process
!<cmd>    - execute <cmd>, then return
quit

format> disk
```

**CODE EXAMPLE 1-1** Procedure for Recovering a Boot Drive's "drive type"

```
AVAILABLE DISK SELECTIONS:
  0. c0t0d0 <SUN72G cyl 14087 alt 2 hd 24 sec 424>
     /pci@0/pci@0/pci@2/scsi@0/sd@0,0
Specify disk (enter its number)[0]:
selecting c0t0d0
[disk formatted]
format> quit
```

The drive type recovery is complete, reboot the server:

```
root@ # reboot
syncing file systems... done
rebooting...
Resetting...
#
SPARC Enterprise T5220, No Keyboard
Copyright 2009 Sun Microsystems, Inc. All rights reserved.
OpenBoot 4.30.4, 3968 MB memory available, Serial #xxxxxxx.
Ethernet address xx:xx:xx:xx:xx:xx, Host ID: xxxxxxxx.
B
oot device: /pci@0/pci@0/pci@2/scsi@0/disk@0,0:a File and args:
SunOS Release 5.10 Version Generic_141414-10 64-bit
Copyright 1983-2009 Sun Microsystems, Inc. All rights reserved.
Use is subject to license terms.
Hostname: host-1
The / file system (/dev/rdisk/c0t0d0s0) is being checked.
Reading ZFS config: done.
host-1 console login:
```

---

# New Information About Documentation Errata

This section describes documentation errors that were discovered since the previous edition of the Product Notes was published.

## *Integrated Lights Out Manager (ILOM) 3.0 CLI Procedures Guide*

### Erroneous Description about Collecting SP Data

The following description in the section "Collect SP Data to Diagnose System Problems" on page 88 includes incorrect information.

Variable	Option	Description
<i>data</i>	<code>full</code>	Specifies that all data is to be collected ("full" collection). <b>Note</b> - Using this option may reset the running host.

On the SPARC Enterprise T-series servers, when you specified the `full` option, the host in execution will not be reset. While the host is executing, you can specify the `full` option.

## *Integrated Lights Out Manager 3.0 Web Interface Procedures Guide*

### Erroneous Description about Collecting SP Data

The following description in the section "Collect SP Data to Diagnose System Problems" on page 79 includes incorrect information.

3. Select the desired Data Set: `Normal`, `Full`, or `Custom`.

- **Normal** – Specifies that ILOM, operating system, and hardware information is collected.



- **Full** – Specifies that all data is to be collected. Selecting Full might reset the system.
- **Custom** – Allows you to choose one or more of the following data sets:
  - ILOM Data
  - Hardware Data
  - Basic OS Data
  - Diagnostic Data

On the SPARC Enterprise T-series servers, when you specified the `full` option, the host in execution will not be reset. While the host is executing, you can specify the `full` option.



## Important Information About the SPARC Enterprise T5120 and T5220 Servers

---

This chapter describes important information about the SPARC Enterprise T5120 and T5220 servers.

The following sections are included:

- “Notes on DVD Drive and Discs” on page 15
- “Supported Versions of the OS and Firmware” on page 16
- “Solaris OS and Firmware Requirements for Certain Features” on page 17
- “Preinstalled Software” on page 18
- “Mandatory Patch Information” on page 22
- “General Functionality Issues and Limitations” on page 24
- “Processor Identification” on page 25
- “Notes on the Use of 200V Power Supply” on page 26

---

### Notes on DVD Drive and Discs

See the “Notes on DVD Drive and Discs in SPARC Enterprise” on the website below before using the CD/DVD discs in the standard DVD drive mounted in this server.

<http://www.fujitsu.com/sparcenterprise/manual/>

---

# Supported Versions of the OS and Firmware

[TABLE 2-1](#) lists the versions of Solaris OS and system firmware supported for SPARC Enterprise T5120 and T5220 servers.

Your server is preinstalled with the latest supported OS, patches and firmware. If you decide to install some other supported version, be certain to also install the patches required by that version. For information on OS patch requirements, see [“Mandatory Patch Information” on page 22](#).

---

**Note** – If you install an OS over the preinstalled OS (even if it is the same version) you will overwrite the supplementary software that was preinstalled at the factory. See [“Preinstalled Software” on page 18](#) for more information on this additional preinstalled software.

---

---

**Note** – Some optional features require certain versions of the OS and System Firmware. See [“Solaris OS and Firmware Requirements for Certain Features” on page 17](#).

---

**TABLE 2-1** Supported Versions of the OS and Firmware

---

Supported Versions	
<b>OS</b>	Solaris 10 8/07 OS plus mandatory patches - Minimum supported OS Solaris 10 5/08 OS plus patches Solaris 10 10/08 OS Solaris 10 5/09 OS Solaris 10 10/09 OS - Latest supported OS
<b>Firmware</b>	System Firmware 7.0.9 - Minimum supported System Firmware System Firmware 7.2.7.b - Latest supported version (as of March 2010)

---

---

**Note** – When installing the Solaris 10 8/07 OS or Solaris 10 5/08 OS on a server equipped with a USB SATA DVD drive, see [“Notes on Installing Solaris 10 8/07 OS and Solaris 10 5/08 OS” on page 60](#).

---

---

# Solaris OS and Firmware Requirements for Certain Features

The following table identifies the minimum OS and firmware versions required to support certain features.

**TABLE 2-2** Minimum OS and Firmware Version Requirements for Certain Features

Feature	Minimum Firmware Version	Minimum OS Version
Mixed memory configurations*	7.1.6.d	N/A
Systems using the External I/O Expansion Unit	7.1.6.d	Solaris 10 10/08 OS
Systems operating with DC power supplies	7.1.6.j	Solaris 10 10/08 OS
8 disk-capable T5120 servers	7.1.6.j	N/A
16 disk-capable T5220 servers	7.1.6.j	N/A
1.6 GHz processors	7.2.2.e	N/A
ILOM 3.0 firmware	7.2.2.e	N/A
LDoms 1.2 †	-	-
LDoms 1.3 †	-	-

\* When installing the following optional FB-DIMMs into servers running with system firmware older than 7.1.6.d, you need to update the firmware to 7.1.6.d or later.  
- Optional FB-DIMMs: 'SESX2A2\_(1GBx2)' or 'SESX2B2\_(2GBx2)'  
Make sure that all FB-DIMMs in the server have the same capacity. For details, contact your service engineer.

† For minimum firmware version, minimum OS version, and mandatory patches when using LDoms software, see the *Logical Domains Guide*.

---

**Note** – To benefit from the accumulated features, enhancements, and fixes, upgrade your system firmware to the most recent version available.

---

## System Firmware

The System Firmware controls various aspects of the host and the service processor. The System Firmware comprises the following individual firmware components:

- Integrated Lights Out Manager (ILOM) firmwares
- OpenBoot™ firmware

- POST firmware
- Hypervisor firmware
- VBSC firmware

System Firmware updates are available from the following web site as patch releases.

<http://www.fujitsu.com/global/services/computing/server/sparcenterprise/downloads/firmware/>

When you update the System Firmware, all of the individual firmware components are updated. You cannot update firmware components individually. Refer to the *SPARC Enterprise T5120 and T5220 Servers Installation Guide* for more information about updating the server firmware.

---

## Preinstalled Software

This section describes the following:

- Preinstalled software (TABLE 2-3) that is ready to use.

**TABLE 2-3** Preinstalled Software

Software	Location	Function
Solaris 10 5/09 OS	The root (/) partition is installed on Slice 0. The core OS is on Slice 3, serving as a Live Upgrade alternate boot environment (ABE).	Operating system and alternate boot environment. See “Solaris 10 OS and Solaris Live Upgrade” on page 19.
CMT Tools 1.0	/opt/SUNWspro/extra/bin	Sun Studio Developer Tools
Cool Tools GCC v. 4.0.4	/opt/gcc and /opt/SUNW0scgfss	GCC compiler for SPARC systems. See “Additional Software Available for Your Server – Cool Tools” on page 19.
LDoms Manager	/opt/SUNWldm	Manages Logical Domains.
LDoms MIB	/opt/SUNWldmib	LDoms Management Information Base.
Sun Studio 12 Developer Tools	/opt/SUNWspro/extra/bin /opt/SUNWspro	Sun Studio Developer Tools. See “Sun Studio C, C++ & Fortran Compilers and Tools” on page 21.

---

**Note** – Previously, the Sun Java Enterprise System software package was placed in the `/var/spool/stage/JES5/Solaris_sparc` directory at the factory. This is no longer the case. If you want to install the Sun Java Enterprise System software, download it from: <http://www.sun.com/software/javaenterprisesystem>.

---

## Solaris 10 OS and Solaris Live Upgrade

The Solaris 10 OS is completely installed on your system, including everything installed by the “Entire Distribution plus OEM support” option. This software includes all the locales supported by this Solaris release. In addition, some patches are preinstalled on your server. See “[Mandatory Patch Information](#)” on page 22.

---

**Note** – Some software that is provided in the Solaris OS media kit has not been installed on your system. If you want to use the additional software, obtain the full media kit for this Solaris release and install software from the included discs. Order the appropriate media kit for the version preinstalled on your system.

---

Your server is configured with a `liveupgrade` partition on Slice 3 that contains a duplicate of the Solaris OS (core only). The `liveupgrade` partition is known as an alternate boot environment (ABE). This technology enables the Solaris OS to run normally during an upgrade or normal maintenance on an inactive boot environment.

For more information about Solaris Live Upgrade, go to:

<http://www.sun.com/software/solaris/liveupgrade>

## Additional Software Available for Your Server – Cool Tools

Cool Tools provide a collection of freely available tools that enable fast and efficient development and deployment of optimally configured software solutions on CoolThreads™ servers. These tools significantly improve performance and time-to-market development for applications running on these servers.

An overview of the Cool Tools and full documentation is available at:

<http://www.sun.com/servers/coolthreads/overview/cooltools.jsp>

Not all of the Cool Tools listed on the Cool Tools web page are preloaded on your server. Refer to information at the Cool Tools web site for additional tools you can download and install on these servers.

## Logical Domains

A logical domain is a discrete logical grouping with its own operating system, resources, and identity within a single computer system. Each logical domain can be created, destroyed, reconfigured, and rebooted independently, without requiring a power cycle of the server. You can run a variety of applications software in different logical domains and keep them independent for performance and security purposes.

Using Logical Domains (LDoms) increases your server usage, efficiency, and return on investment, and also reduces your server footprint. The LDoms Manager software creates and manages logical domains, and maps logical domains to physical resources.

---

**Note** – The LDoms MIB must be configured before you can use it. A README file with configuration instructions is located in the LDoms MIB installation directory, `/opt/ldoms_mib`.

---

For more information on LDoms, go to:

<http://www.fujitsu.com/global/services/computing/server/sparcenterprise/products/software/ldoms/>

## Supported Sun Explorer Utility Version

Sun Explorer is a diagnostic data collection tool. The tool comprises shell scripts and a few binary executables. Sun Explorer runs on the Solaris OS.

The SPARC Enterprise T5120 and T5220 servers are supported by the Sun Explorer 5.10 (or later) data collection utility, but are not supported by earlier releases of the utility. Determine whether an earlier version of the Sun Explorer product has been installed on your system by typing the following:

```
# pkginfo -l SUNWexplo
```

If an earlier version exists, uninstall it and install version 5.10, or later. For information on how to get the Sun Explorer Utility, please contact a certified service engineer.



# Sun Studio C, C++ & Fortran Compilers and Tools

Sun Studio delivers high performance by optimizing C, C++, and Fortran compilers for the Solaris OS on multicore systems.

For an overview and documentation, go to:

<http://developers.sun.com/sunstudio/index.jsp>

---

# Mandatory Patch Information

Patches are available at:

Global Site

<http://www.fujitsu.com/global/support/software/security/products-s/patch-info/>

Japanese Site

<http://software.fujitsu.com/jp/security/products-others/unix/>

North American Site

<https://download.computers.us.fujitsu.com/>

Before contacting support, ensure that all mandatory patches are installed on your server. In addition to applying the periodic PTF, check the above web site on a regular basis for the availability of new patches.

## Mandatory Patches for the Solaris 10 8/07 OS

[TABLE 2-4](#) lists the mandatory patch that is needed for servers running the Solaris 10 8/07 OS. This patch was installed along with the OS at the factory. If you reinstall the server with the Solaris 10 8/07 OS, you must reinstall this patch.

**TABLE 2-4** Mandatory Patch for Servers Installed with the Solaris 10 8/07 OS

Patch IDs	Description	Fixes Provided
127127-11 or later	SunOS 5.10: kernel patch	Includes the following fixes: <ul style="list-style-type: none"><li>• CR 6590132: System panics (n2cp alignment error) in IPsec testing</li><li>• Issues regarding data integrity in the nxge driver as reported by Sun Alert ID 103076</li><li>• CR 6568352: IPsec performance does not scale using hardware crypto providers</li></ul>

To determine if a patch is present, see [“To Download Patches” on page 23](#).

## Mandatory Patches for the Solaris 10 5/08 OS

There are no mandatory patches for the Solaris 10 5/08 OS at this time.

## Mandatory Patches for the Solaris 10 10/08 OS

There are no mandatory patches for the Solaris 10 10/08 OS at this time.

## Mandatory Patches for the Solaris 10 5/09 OS

There are no mandatory patches for the Solaris 10 5/09 OS at this time.

### ▼ To Download Patches

**1. Determine whether the patches have been installed on your system.**

For example, use the `showrev` command for each patch number:

```
# showrev -p | grep "Patch: 127753"
```

- If you see patch information listed for the queried patch, and the dash extension (the last two digits) matches or exceeds the required version, your system has the proper patches already installed and no further action is required.

For example, if patch 127127-11 or later is installed, your system has the required version of this patch.

- If you do not see patch information listed for the queried patch, or if the dash extension precedes the required version, go to [Step 2](#).

For example, if 127127-09 is displayed you must download and install the patch.

The last two digits of the patch ID represent the revision of the patch.

**2. Access the above-mentioned web site to download the patches.**

**3. Follow the installation instructions provided in a specific patch's README file.**

## Patches for Option Cards

If you add option cards to your server, refer to the documentation and README files for each card to determine if additional patches are needed.

## Installing the 4Gbps Fibre Channel card

Once you install the 4Gbps Fibre Channel card (SE0X7F11X, SE0X7F12X), the patch indicated below is required. Access the above-mentioned web site to download the patch. Follow the installation instructions provided in the README file for the patch.

Optional cards

- Single-channel 4Gbps Fibre Channel card (SE0X7F11X)
- Dual-channel 4Gbps Fibre Channel card (SE0X7F12X)

Required patch

- FUJITSU PCI Fibre Channel 4.0: 914583-04 or later

---

## General Functionality Issues and Limitations

This section describes general issues known to exist at this release of the SPARC Enterprise T5120 and T5220 servers.

### Cryptographic Function

The IPsec capability of the on-chip cryptographic accelerator in the UltraSPARC T2 multicore processor is a mechanism that cannot be used unless the IPsec activation package has been installed. As the IPsec activation package is presently not supported by Fujitsu, the IPsec function cannot be used in Fujitsu-brand servers.

### RAID Function

A hardware RAID function is provided as standard in SPARC Enterprise T5120 and T5220 servers. However, with regard to data protection, reliability, and serviceability, Fujitsu does not support this function.

Fujitsu recommends use of software RAID functions for internal disks as specified below:

- PRIMECLUSTER GDS
- Solaris Volume Manager (attached to Solaris OS)

## Cable Management Arm

The SPARC Enterprise T5120 server does not support the cable management arm (CMA).

The following restrictions apply when using a CMA on SPARC Enterprise T5220 servers:

- The maximum capacity of the CMA is as follows:
  - AC input power model : 2 AC cables and 6 RJ45 cables
  - DC input power model : 6 DC cables and 6 RJ45 cables
- Optical fiber cables cannot be accommodated in the CMA. Route the cables through the free space on top of the CMA.
- Cables with a cable core (such as SCSI cables) cannot be accommodated in the CMA. Route the cables through the free space on top of the CMA.

Moreover, if it hampers to install optional products that are subject to the following structural restriction, first uninstall and remove the CMA.

- Cables with large connectors (such as for an XVR-300 or SAS card) must be connected to the top PCIe slot.

## Express Rail Rackmounting Kit

Installing the servers with the express rail rackmounting kit is not supported.

## SSD (Solid State Drive)

SSD (Solid State Drive) is not currently supported.

## SAS RAID Internal HBA Card

SAS RAID Internal HBA Card is not currently supported.

---

## Processor Identification

Processor IDs might not start at 0, and might not be contiguous.

Different platforms and platforms of the same model might have different processor IDs for identical configurations. For example, on UltraSPARC® T1 CPU based platforms, the processor IDs start with processor ID 0 but other platforms, including those based on the UltraSPARC T2 CPU, might not have a processor ID 0. The Solaris `psrinfo` command might display output similar to the following for platforms based on the UltraSPARC T2 processor:

8	on-line	since 09/18/2007 21:26:25
9	on-line	since 09/18/2007 21:26:30
16	on-line	since 09/18/2007 21:26:30
17	on-line	since 09/18/2007 21:26:30

The processor IDs might have significance if you are running LDoms. The processor IDs exported to a guest domain on a platform running multiple guest domains with a virtual machine manager might represent a virtual abstraction. Within each guest domain, each processor ID visible to the software will be a unique integer value.

Software running in different guest domains on the same physical machine might see the same or different sets of virtual processor IDs. If the server is running LDoms, the virtual processor IDs and physical processor IDs are never the same. For information about the mapping between virtual and physical CPU numbers, refer to the latest *Logical Domains (LDoms) Administration Guide*.

Processor IDs are unique integer values in the domain where the software is running. The integer value fits in the type `processorid_t`. Also refer to the `p_online(2)` man page.

---

## Notes on the Use of 200V Power Supply

For the servers that have the B-type plug, confirm that a 15A overcurrent protection device is available outside the server. If one is not available, prepare an external 15A overcurrent protection that can be achieved by means of no-fuse breakers (NFBs) or fuses. The B-type plug refers to plugs other than grounding-type ones with two parallel blades, such as the NEMA L6-30, L6-20, L6-15, and L5-15.

For details of the power cord type for your server, contact your authorized service engineer.

## Known Issues

---

This chapter describes known issues about the SPARC Enterprise T5120 and T5220 servers.

The following sections are included:

- [“Hardware and Mechanical Issues”](#) on page 28
- [“Ethernet Interface Related Issues”](#) on page 31
- [“Firmware, ILOM, POST, and SP Issues”](#) on page 33
- [“Solaris OS Issues”](#) on page 56
- [“LDDoms Related Issues”](#) on page 62

---

**Note** – For the issues already fixed in the latest version of Solaris OS or System Firmware, see [Appendix A](#). For the latest version to be supported, see [“Supported Versions of the OS and Firmware”](#) on page 16.

---

---

# Hardware and Mechanical Issues

**TABLE 3-1** lists the late-breaking hardware and mechanical issues. Additional information for some of the issues is provided after the table.

**TABLE 3-1** Hardware and Mechanical Issues

CR	Description	Workaround
n/a	Hot-swapping fan modules requires careful fan removal.	When removing a fan module, hold the adjacent fan module in place to avoid unintentionally dislodging the adjacent fan module.
n/a	All disk LEDs blink simultaneously about every 16 seconds when a RAID volume is created.	Be aware that the blinking LEDs are a normal condition.
6550166 6667545	Components on the motherboard are hot to the touch.	When replacing components in the system chassis, wait for components to cool down, approximately one minute, prior to performing service actions.
6574127 6480945	If a hard drive fails in RAID 0 or RAID 1 configurations, error messages might not be displayed on the console or in the log files.	<p>If you encounter failed disks in RAID 0 or RAID 1 configurations, and you see the following scenario, the disk drive should be replaced:</p> <ul style="list-style-type: none"><li>• The Fault LED is lit on a disk drive that is part of a RAID0 or RAID1 volume.</li><li>• The error condition can be displayed remotely by running the <code>showenvironment</code> command on the service processor.</li><li>• The hard drive that has the Fault LED illuminated displays a status of <code>Failed</code> and the service indicator is set to <code>ON</code>.</li></ul> <p>Replace the disk drive with the lit Fault LED.</p>
6616232	<p>Power supply fan faults are not automatically cleared.</p> <p>If a fault is detected for a power supply fan, and the fan returns to normal operation, the fault indication is not automatically cleared.</p>	Power cycle the power supply that has the fan fault to clear the fault.
6674290	In the SPARC Enterprise T5220 server, if a XAUI card and a PCIe card are installed on the same riser assembly, the XAUI card might fail POST and be disabled when the server boots.	If possible, do not install any PCIe cards in the same riser assembly as a XAUI card.



**TABLE 3-1** Hardware and Mechanical Issues (*Continued*)

CR	Description	Workaround
n/a	When the system is initialized, firmware is loaded and occupies approximately 128 MB to 352 MB of the host memory. The banner and other software utilities report an amount of memory minus the amount of memory that is occupied by firmware.	When viewing the amount of memory in the banner, be aware that the banner reports the amount less what is used by the firmware.
n/a	An RJ45 cable may sometimes be difficult to disconnect from an RJ45 port of an Ethernet card mounted in the SPARC Enterprise T5120.	In this event, disconnect the cable while keeping the RJ45 cable connector tab depressed, such as with a plastic card.
(Bug ID 6581309)	To use the XVR-300 as a console of the SPARC Enterprise T5xx0, patch 137111-01 or later must be applied. If the patch is applied after the OBP variable has been changed to use the XVR-300 as the console, console output will revert to the default ILOM console during the Solaris boot sequence.	To use the XVR-300 as a console, apply patch 137111-01 or later to the Solaris OS before changing the OBP variable. Alternatively, install the Solaris OS (or reinstall it) with ILOM set as the console used, and then apply the patch. No GUI can be used during that time. After the patch has been applied, the XVR-300 can be used as the console as soon as the OBP variable is changed.
6706976	At write to CD/DVD media, there may be cases where the writing speed may not reach the maximum speed supported by the CD/DVD drive. Even if the maximum operation is not reached, there are no problems in the processing for writing to the CD/DVD media.	Use the media as is.
6840287	When a server is power cycled with DVD media installed, the message "Device is gone" will be displayed approximately 30 minutes after the OS is booted up.	Ignore the message.
6857080	Systems with firmware version 7.2.2.x have low fan speed (5000 rpms). The low fan speed condition can result in SC Alerts that warn of the low fan speed.	Ensure that the air flowing into the server is within the ambient temperature specification.
n/a	The On/Standby portion of the service label contains an error. It says to press and hold the On/Standby button for "5 seconds". It should say "4 seconds".	<b>Note</b> - This error appears on the service labels on all SPARC Enterprise T5120 and T5220 server configurations.
n/a	Some service labels show an extra fan module in step 2 of the four-step fan board diagram. The extra fan is on the right half of FanBD0.	<b>Note</b> - This error appears on the service label for SPARC Enterprise T5120 servers with 4-disk capable backplanes.

**TABLE 3-1** Hardware and Mechanical Issues (*Continued*)

<b>CR</b>	<b>Description</b>	<b>Workaround</b>
n/a	On service labels that show the locations of PCIe and XAUI slots, the XAUI callouts are wrong. They should point to the lower slots.	<b>Note</b> - This error appears on the service labels for SPARC Enterprise T5220 servers.
n/a	The FM Status Indicator portion of the service label has an erroneous statement. Where it says, "In front of FM on FanBD" it should say, "on top of FM".	<b>Note</b> - This error appears on the service labels for SPARC Enterprise T5220 servers.
n/a	The drawing showing the cable management arm being rotated represents the wrong server model. It should show the SPARC Enterprise T5220 server.	<b>Note</b> - This error appears on the service labels for SPARC Enterprise T5220 servers.
n/a	The Fan Module Configuration portion of the service label is wrong. It should show fan modules in location FANBD1, FM1.	<b>Note</b> - This error appears on the service labels for SPARC Enterprise T5220 servers with 16-disk capable backplanes.
n/a	The shapes of anti-tilt legs shown on service labels may be different, depending on racks.	<b>Note</b> - This error appears on the service labels on all SPARC Enterprise T5120 and T5220 servers.

# Ethernet Interface Related Issues

TABLE 3-2 lists the late-breaking Ethernet related issues. Additional information for some of the issues is provided after the table.

TABLE 3-2 Ethernet Related Issues

CR	Description	Workaround
6553515	<p>If a temporary PCIe network link failure occurs during boot or any time later, the system could fail.</p> <p>If the link is up and working again before the firmware gets control, the error is a problem in firmware handling the leftover status. For an example of the error, see <a href="#">“Temporary PCIe Link Failure During Boot Causes a Fatal Error Later (CR 6553515)”</a> on page 31.</p>	<p>If the system fails to boot because of this problem, try booting again.</p>
6606950	<p>There is an important <code>/etc/system</code> setting for 10 Gb Ethernet performance.</p> <p>Note - The preinstalled Solaris OS has the correct entry in the <code>/etc/system</code> file.</p>	<p>If you reinstall the Solaris OS, you must add the following line to the <code>/etc/system</code> file:</p> <pre>set ip:ip_soft_rings_cnt=16</pre> <p>This <code>/etc/system</code> setting ensures optimum performance for 10 Gb Ethernet interfaces.</p>

## Temporary PCIe Link Failure During Boot Causes a Fatal Error Later (CR 6553515)

If a temporary PCIe link failure occurs during boot or any time later, the system could fail. If the link is up and working again before the firmware gets control, the error is a problem in firmware handling the leftover status. The following is an example of the error message:

```
{0} ok 4000 dload users/bog/rustn2obp_0502
Boot device:
/pci@0/pci@0/pci@1/pci@0/pci@2/network@0:,users|bog|rustn2obp_0502 File
and args:
FATAL: /pci@0/pci@0/pci@1/pci@0/pci@2/network@0: Last Trap: Non-
Resumable Error
TL: 1
%TL:1 %TT:7f %TPC:f0238978 %TnPC:f023897c
%TSTATE:820001600 %CWP:0
```

```

%PSTATE:16 AG:0 IE:1 PRIV:1 AM:0 PEF:1 RED:0 MM:0 TLE:0 CLE:0 MG:0 IG:0
%ASI:20 %CCR:8 XCC:nzvc ICC:Nzvc
%TL:2 %TT:3f %TPC:f024327c %TnPC:f0243280
%TSTATE:14414000400 %CWP:0
%PSTATE:4 AG:0 IE:0 PRIV:1 AM:0 PEF:0 RED:0 MM:0 TLE:0 CLE:0 MG:0 IG:0
%ASI:14 %CCR:44 XCC:nZvc ICC:nZvc
Normal          GL=1
0:              0              0
1:              f0200000        0
2:              f0200000        0
3:              fff78000        0
4:              fec320fc        3ffe60000
5:              f02833e4        3ffe60000
6:              fee826c8        3ffe60600
7:              fee817d8        f02432bc
%PC f0238978 %nPC f023897c
%TBA f0200000 %CCR 8200016 XCC:nzvc ICC:nZvc
{0} ok

```

Workaround: If the system fails to boot because of this problem, retry booting.

## Ierrs Are Generated When 100Mb/Full With Forced Speed/Duplex Is Set in e1000g.conf (CR 6555486)

As a result of research, it turned out that this problem had never happened on the condition which we informed before.

It is the case that this problem happens when e1000g sets Auto-negotiaion:off and its link partner sets Auto-negotiation:on, which is specified in IEEE802.3.

Therefore the same problem can be seen on the other drivers than e1000g when it does the same setting.

The following setting is also available on e1000g driver.

- Auto-negotiation : off
- speed : 100Mbps
- Duplex : Full

But we suggest Auto-negotiation be set to "on" because this problem frequently occurs when users who set Auto-negotiation:off to e1000g forget to set Auto-negotiation:off to link partner.

---

# Firmware, ILOM, POST, and SP Issues

TABLE 3-3 lists the late-breaking issues for the firmware, ILOM (including ALOM compatibility CLI), POST, and service processor (SP). Additional information for some of the issues is provided following the table.

TABLE 3-3 Firmware, ILOM, POST, and SP Issues

CR	Description	Workaround
6237994	Registration with DMI could fail with an <code>err=831</code> message.	Disable DMI service at the startup. For example: <pre>% mv /etc/rc3.d/S77dmi /etc/rc3.d/_S77dmi</pre>
6510082	For users familiar with ALOM CMT and using the ALOM CMT compatibility CLI, the help for the <code>consolehistory</code> command displays both a boot and a run option. Both options result in the same output because ILOM makes no distinction between the run and boot buffers.	
6556505	The PCIe link might fail to train as x8. This problem might occur during a power on or reset sequence where the I/O bridge (PCIe root complex) of the UltraSPARC T2 CPU does not properly train the PCIe interface.	For workaround procedures, see “ <a href="#">Problem When the PCIe Link Fails to Train as x8 (CR 6556505)</a> ” on page 43.
6568750	Scripts that log into the SP might timeout after 60 seconds. If this error occurs, the following error message is displayed: <pre>Logging out after 60 seconds.</pre> Note - This error is not seen during normal login, only when logging in with a script.	If you use scripts to log into the SP, be aware of this issue.
6573354	The method for clearing POST results (displayed with the <code>showfaults</code> command) has changed. After POST runs, <code>showfaults</code> displays the status. The only way to clear the status is to enter the <code>setdefaults</code> command. For users familiar with ALOM CMT, the previous way to clear the status was to enter the <code>resetsc</code> command.	To clear POST results, use the ALOM CMT compatibility <code>setdefaults</code> command.
6583567	A communication channel between the primary domain and the service processor (SP) could hang and disable communication over the channel.	See “ <a href="#">Communication Channel Between the Primary Domain and the Service Processor (SP) Might Hang (CR 6583567)</a> ” on page 45.

**TABLE 3-3** Firmware, ILOM, POST, and SP Issues (Continued)

CR	Description	Workaround
6585114	During automated testing, the SP could encounter problems with <code>useradd</code> and <code>usershow</code> commands, followed by the failure of all login attempts.	AC power cycle the system.
6585292	Some extraneous and misleading warning messages are displayed in the output of the ILOM <code>reset /SP</code> command and of the ALOM CMT compatibility <code>resetsc</code> command. For an except of the misleading messages, see <a href="#">“Resetting the SP Produces Extraneous Warning Messages (CR 6585292)”</a> on page 46.	Ignore the extraneous warning messages.
6595955	If a component is not physically present on a system (such as the fan module), the status field in the <code>prtdiag -v</code> (Environmental Status Section) output shows no value and is blank.	
6596430	If the socketed EEPROM (SCC) is replaced, the SP does not always read some SP properties from the new EEPROM. If the SP configuration variable <code>sc_backupuserdata</code> is set to <code>false</code> , the following user configuration values are not backed up to the socketed EEPROM: <code>if_emailalerts</code> , <code>mgt_mailhost</code> , <code>mgt_mailalert</code> , <code>sc_customerinfo</code> , <code>sc_powerondelay</code> , <code>sc_powerstatememory</code> , <code>sc_backupuserdata</code>	Manually copy the user settings before replacing the motherboard in a motherboard swap scenario. After the swap is complete, manually set the user parameters.
6596594	Changed OpenBoot NVRAM parameters do not take affect after a <code>resetsc</code> . If the service processor is reset while the control domain is at the <code>ok</code> prompt, OpenBoot PROM will permanently lose its ability to store nonvolatile LDOMs variables or security keys until the host has been reset. Guest domains are not affected by this problem. Attempts to update LDOMs variables or security keys results in the following warning messages: WARNING: Unable to update LDOM Variable WARNING: Unable to store Security key	After changing variables, reset the control domain using the <code>reset-all</code> command.

**TABLE 3-3** Firmware, ILOM, POST, and SP Issues (Continued)

CR	Description	Workaround
6599333	The ASR database does not support disabling XAUI devices. When a XAUI device is disabled (with ILOM CLI <code>set NACname component_state=disabled</code> , or with the ALOM CMT compatibility <code>disablecomponent</code> command) or due to failures detected by POST, the corresponding network device is still available in the OpenBoot firmware.	
6613212	Though you set <code>user-reset</code> or <code>all-reset</code> to <code>/Host/diag/trigger</code> and execute <code>reset</code> by using the <code>reset /SYS</code> command, POST fails to be executed.	Add <code>"all-resets"</code> or <code>"power-on-reset"</code> to <code>/HOST/diag/trigger</code> .
6614432	Erroneous power supply faults might be displayed. For an example, see <a href="#">"Erroneous Power Supply Faults (CR 6614432)" on page 47</a> . Some servers report a low AC line input voltage fault when the input voltage is in the range of 90V to 94V AC. This threshold is incorrect and should not indicate an AC input fault until the voltage drops below 90V AC.	Ensure that both server power supplies are operating. When both power supplies are operating, the server will remain powered on during and after erroneous faults.
6614568	In ILOM mode, though you send the break request to OS, you cannot obtain the <code>ok</code> prompt. -> <code>set /HOST send_break_action=break</code> Set <code>'send_break_action'</code> to <code>'break'</code>  At this time, the following message appears on the OS console; but none of the options can obtain the <code>ok</code> prompt. # Debugging requested; hardware watchdog suspended. c)ontinue, s)ync, r)eset?	None. When the <code>auto-boot?</code> parameter is set to <code>false</code> , <code>ok</code> prompt can be displayed by selecting <code>s</code> or <code>r</code> . Selecting <code>c</code> returns you to the Solaris OS. However, when the <code>auto-boot?</code> parameter is set to <code>true</code> , none of the options can obtain the <code>ok</code> prompt. For the details, see the section <i>"OpenBoot ok Prompt"</i> in the <i>SPARC Enterprise T5120 and T5220 Servers Administration Guide</i> .
6624705	When a component set disable by using "Component Management" of BUI, on the screen of an ALOM mode log-in user, a message appears which supposed to be shown when the command executed from CLI. Fault   critical: SP detected fault at time Wed Jul 18 09:37:15 2007. <code>/SYS/MB/GBE1 Disabled by CLI action.</code>	None.

**TABLE 3-3** Firmware, ILOM, POST, and SP Issues (Continued)

CR	Description	Workaround
6627396	If you keep on continuously executing the command in the service processor that you logged in, the return of command slows down. Or errors might occur.	If ILOM has been used at least once, log out from ILOM. When problems arise, AC power-cycle the system.
6628377	Though you disable the TTYA by using the ILOM command, it doesn't turn disable and you can log in to OS.	None.
6662997	If you change any firmware variables (such as <code>auto-boot?</code> ), keep a record of your changes. In the event of a motherboard replacement, most of the SP variables will become the default values. The service manual indicates that moving the SCC module to the new motherboard will preserve customized variables, but this is not true because not all variables are stored in the SCC module. The following variables are stored in the SCC module, and will be preserved when the SCC module is moved to a replacement motherboard: <ul style="list-style-type: none"> <li>• Host ID</li> <li>• Mac addresses</li> </ul> All other variable values will become default values.	Keep a record of any firmware variables that are modified. In the event that the motherboard is replaced, use your record of customized variables to manually modify the firmware variables on the new motherboard.
6636098	If a built-in fan is erroneously detected as a failure and reported as such to the Enhanced Support Facility software or Server System Manager software, an error message is displayed: For an example of the errors, see <a href="#">“A Built-In Fan May be Erroneously Detected as a Failure (CR 6636098)”</a> on page 48.	<b>Note - Enhanced Support Facility patch 914604-04.</b> Since these messages do not have an effect on your system behavior, ignore these messages.
6723410	If you repeat in sequence a login to the service processor, executing a command, and logging out, logout may fail.	If this problem occurs, terminate the login session on the client from which you have accessed the service processor.



**TABLE 3-3** Firmware, ILOM, POST, and SP Issues (Continued)

CR	Description	Workaround
6760139	ILOM firmware and OpenBoot PROM (OBP) setting information may not be inherited during motherboard replacement.	If an ILOM firmware initialization has been performed or any of the firmware settings have been changed, follow the procedure below to save the latest ILOM firmware setting information. After replacing the motherboard, set the saved setting information again. (Procedure for saving ILOM firmware setting information) 1) Log in to ILOM, execute the following commands, and save the displayed results: -> <b>show /SP -level all -o table</b> -> <b>show /SYS -o table</b> -> <b>show /HOST -level all -o table</b> 2) Log in to the ALOM CMT compatibility shell, execute the following command, and save the displayed results: sc> <b>showsc</b>
6762635	One of the following messages may be output while a POST (self-diagnostics test) is in progress, and POST processing may not be completed. Also, a transition to OpenBoot PROM (OBP) may occur. Message examples: Fault Sensor VMEML_POK at /SYS/MB deasserted Fault Sensor VCORE_POK at /SYS/MB deasserted Fault Sensor VMEMR_POK at /SYS/MB deasserted	(Recovery procedure) Disconnect and then reconnect the power cable.
6761778	The following error message may be displayed: Message example: picld[154]: [ID 276222 daemon.error] PICL snmpplugin: sunPlatSensorClass 0 unsupported (row=388)	Ignore this message.

**TABLE 3-3** Firmware, ILOM, POST, and SP Issues (Continued)

CR	Description	Workaround
6752910	<p>After a host power-on instruction is executed from ILOM, the POST (self-diagnostics test) may not start, and processing may not go to OS boot processing or the <code>ok</code> prompt for OpenBoot PROM (OBP).</p> <p>For details, see <a href="#">“After a Host Power-On Instruction is Executed from ILOM, the POST May Not Start, and Processing May Not Go to OS Boot Processing or the <code>ok</code> Prompt (CR 6752910)”</a> on page 49.</p>	<p>After turning off the power to the host, wait at least three minutes before turning it on again.</p>
6726663	<p>In ILOM mode, or through access to the ILOM Web, it may be possible to change the system time when the system is powered on.</p>	<p>In ILOM mode, be sure not to change the properties displayed below at power on so as not to change the system time directly or enable NTP services.</p> <pre>-&gt; <b>show /SP/clock</b>  /SP/clock Targets:  Properties:   datetime = Wed Dec  3 06:22:48 2008   usentpserver = disabled  Commands:   cd   set   show  -&gt;</pre>
n/a	<p>The following error message may be output during POST. Since the error has no impact on system operation, you can ignore the message.</p> <pre>0:0:0&gt;Begin: Block Mem Test 0:0:0&gt;Block Mem Test 00000000. 02000000- &gt;00000008. 00000000 0:0:0&gt;          FBR Error Tally Branch <u>3</u> = <u>2</u>  _ = Indefinite value</pre>	None.

**TABLE 3-3** Firmware, ILOM, POST, and SP Issues (Continued)

CR	Description	Workaround
6815369	For DC input power models, /PS0/AC_POK and /PS0/DC_POK identify sensors in the power supply units. /PS0/AC_POK does not represent an AC power supply unit. For examples, see <a href="#">“For DC Input Power Models, /PS0/AC_POK Is Displayed (CR 6815369)”</a> on page 50.	None.
6746677	According to the IPMI PET warning and SNMP trap warning settings in the warning rule settings, warning message creation may not be possible depending on the event type, irrespective of the warning level. All generated events can be confirmed with show /SP/logs/event/list or showlogs.	None. See <a href="#">“According to the IPMI PET Warning and SNMP Trap Warning Settings in the Warning Rule Settings, Warning Message Creation may not be Possible Depending on the Event Type (CR 6746677)”</a> on page 51.
6806268	The flashupdate (ALOM CMT command) with the -v option doesn't display the details of the execution result.  The -v option exists to maintain compatibility with the earlier ALOM. The -v option specified doesn't affect the system firmware download and update. The result shows no details and will be the same as the execution result without the option.	None.
6823561	In the back up and restore functions of ILOM settings, you cannot set "https" to the protocol for data transfer (transfer_method property).  Example: -> set dump_uri= https://ipaddress/directory/filename set: Unable to transfer image, please check URI	None. Use other protocols (tftp, ftp, sftp, scp, http).
6830397	In ILOM3.0, you cannot set "service" to the /HOST/diag mode property or the diag_mode property of the ALOM CMT compatible shell. If you set, it is displayed as "unknown."	None. The following settings offer the POST diagnosis in a mode equivalent to the "service."  /HOST/diag mode = normal /HOST diag level = max /HOST verbosity = max

**TABLE 3-3** Firmware, ILOM, POST, and SP Issues (Continued)

CR	Description	Workaround
6829248	The alert rule configuration using the SNMP trap fails in the filtering of alert levels. When you select the minor or any upper levels, alerts of all levels will be notified to the SNMP trap.	None.
6836426	In the Logical Domains environment, after the host reset operation, host may be reset again. For the example, see <a href="#">“In the Logical Domains Environment, After the Host Reset Operation, Host May Be Reset Again (CR 6836426)”</a> on page 52.	None. The second reset has no impact on the system.
6835863	During the execution of SunVTS, there may be the following warning message on the OS console and the system log output. Message example: WARNING: ldc_close: (0xc) unregister failed, 11	None. This message has no impact on the system and can be safely ignored.
6835866	During the execution of SunVTS for SPARC Enterprise T5220 Server, there may be an event log output to show that the total power consumption sensor (/SYS/VPS) detected an excess of the power consumption over the threshold value.  IPMI  major : "ID = 21 : 04/26/2009 : 08:04:11 : Power Unit : /SYS/VPS : Upper Critical going high : reading 1262.60 > threshold 1109.20 Watts"  IPMI  minor : "ID = 22 : 04/26/2009 : 08:04:17 : Power Unit : /SYS/VPS : Upper Critical going low : reading 761.10 < threshold 1109.20 Watts"	None. This is not a problem as far as the excess power consumption has been restored to the normal value.
6835854 6779753	In case that the NET-MGT port of ILOM has not been connected with the LAN cable and the network gateway is not set, the ILOM network configuration cannot be set. For the output example, see <a href="#">“The ILOM Network Configuration Cannot Be Set (CR 6835854, 6779753)”</a> on page 53.	None. Connect the LAN cable to the NET-MGT port of ILOM and then set the network configuration.

**TABLE 3-3** Firmware, ILOM, POST, and SP Issues (Continued)

CR	Description	Workaround
6853383	On SPARC Enterprise T5220 Server, after the Solaris OS panic occurred and while collecting the OS panic core dump, the ILOM watchdog timer occasionally detects it as an error and may reset the system. In this case, the OS panic core dump is not collected.	None.
6858772	snmpd can sometimes become unresponsive during the creation of snmpv3 users. This will result in a core dump.	None.
6856315	Using show /SP/user/adminusr password returns show: Invalid command syntax. It should return "*****".	None.
n/a	As of System firmware 7.1.6.d, the following type of message might be displayed on the console and in the logs: Chassis   major: Hot insertion of /SYS/MB/CMP0/P0 or SC Alert: [ID 639621 daemon.error] SC unretrieved msg: [Chassis   major: Hot insertion of /SYS/MB/CMP0/P3]  Chassis   major: Hot removal of HDD3 or SC Alert: [ID 677427 daemon.error] SC unretrieved msg: [Chassis   major: Hot removal of HDD3]	Be aware that these messages are not necessarily error messages.  Messages referring to hot-insertions of CPUs or messages referring to hot-insertions/removals of a nonexistent device are displayed at power on if the system has had a firmware upgrade or system component change. Once the components have been identified, no subsequent messages are displayed unless ILOM detects a change in the system configuration or if hardware failure occurs.
6902381	When an AC cable is connected to the server, or when the server is powered on, all LEDs (or all LEDs on the right side) on the front panel may light up. This problem affects only the LED display; it does not affect system operation. Moreover, entering one of the ILOM status confirmation commands (such as the showenvironment command) will display the status of the system correctly.	None. If this problem occurs, power off the host, reconnect the AC cable to the system, and power on the host again.

**TABLE 3-3** Firmware, ILOM, POST, and SP Issues (Continued)

CR	Description	Workaround
11210193	<p>If an error occurs during POST execution, "Fault Sensor VCORE_POK at /SYS/MB deasserted" may be registered when the <code>showfaults</code> ALOM CMT compatibility command is used for status confirmation. However, POST will still end normally in this case.</p> <p>For an example, see <a href="#">"An Error is Registered with the <code>showfaults</code> Command When Running POST, But POST Ends Normally (CR 11210193)" on page 54.</a></p>	None. If this problem occurs, use the <code>resetsc</code> ALOM CMT compatibility command to clear the log and reset the LED display.
11215994	In rare circumstances, the <code>ok</code> prompt may not be displayed normally after POST execution ends.	See <a href="#">"The <code>ok</code> Prompt is Not Displayed After POST Ends (CR 11215994)" on page 55.</a>
6739633	<p>When the host is off, any <code>prepare_to_remove</code> operation for the component selected in the ILOM Web interface (System Information tab -&gt; Components tab) may cause the radio button of the component to disappear.</p> <p>In the "Ready to Remove Status" column, "NotReady" changes to "Ready (No Power)" for the component, but "Return to Service" cannot be performed for the component because the radio button is no longer displayed.</p>	<p>Make the following setting from the CLI:</p> <ul style="list-style-type: none"> <li><code>set /SYS/(selected-component) return_to_service_action=true</code></li> </ul>
6738510	Specifying the <code>-t</code> option in certain commands ( <code>create</code> , <code>delete</code> , <code>exit</code> , <code>load</code> , <code>reset</code> , <code>set</code> , <code>start</code> , <code>stop</code> , <code>version</code> ) may cause a forced logout from the ILOM CLI.	None.
6739602	<p>If the <code>logdetail</code> property in <code>/SP/clients/activedirectory</code> is set to a value other than "none," the following authentication error message may be displayed even if ActiveDirectory is set to disabled (state = disabled):</p> <pre>sc&gt; ActDir   critical: (ActDir) authentication status: auth-ERROR</pre>	If ActiveDirectory is set to disabled, ignore the message.
6837115	On the ILOM Web interface, when you change the "Alert Management" settings from "Level: minor" and "Type: IPMI PET" to "Type: SNMP Trap" the level setting changes to "disable." The level must be set again.	None.

**TABLE 3-3** Firmware, ILOM, POST, and SP Issues (Continued)

CR	Description	Workaround
6765542	While the external I/O expansion unit is being powered on, when you power off/on the server, the SNMP information of the external I/O expansion unit may fail to be obtained. It can be recovered by removal/insert of the power cord of the external I/O expansion unit and power-off/on of the server.	None.
6881020	When you set /HOST bootfailrecovery to powercycle, powercycle (host power-off/on) fails to be executed.	None.
6883269	After downgrading the system firmware from 7.2.x to 7.1.x, "Condition" of the I_USB0 and I_USB1 may be displayed as "fail" in the output of <code>prtdiag -v</code> command. It can be recovered by removal/insert of the power cords. Output Example: Voltage indicators: ----- Location    Indicator    Condition ----- SYS/MB      VCORE_POK    ok SYS/MB      VMEML_POK    ok SYS/MB      VMEMR_POK    ok SYS/MB      I_USB0       fail    <- SYS/MB      I_USB1       fail    <-	None.

## Problem When the PCIe Link Fails to Train as x8 (CR 6556505)

The system could encounter a problem during a power-on or reset sequence where the I/O bridge (PCIe root complex) of the UltraSPARC T2 CPU does not train at all or trains at a lane width less than 8, and no error or fault is generated to indicate to the user this problem has been encountered.

## ▼ To Identify the Problem

Though no error or fault is reported, it is easy to identify because no PCIe I/O devices will be available to the system. If you power on the system, or reset the domain and try and boot from a disk or network device, and you get an error similar to the following:

```
{0} ok boot disk
Boot device: /pci@0/pci@0/pci@2/scsi@0/disk@0  File and args:
ERROR: boot-read fail

Can't locate boot device

{0} ok
```

1. **At the ok prompt, issue the show-devs command.**
2. **Check the output to for PCIe devices.**  
If no PCIe devices are displayed, the server has encountered this problem.

---

**Note** – All PCIe devices begin with the path /pci@0/pci@0.

---

## ▼ To Correct the Problem

1. **Take down all domains and power off the system.**
2. **Run power-on-self-test (POST) to identify whether this is a persistent failure or not.**

To enable POST, use the `setsc` (an ALOM CMT compatibility CLI command) and configure POST to run at max level.

For example:

```
sc> setsc diag_mode normal
sc> setsc diag_level max
```

3. **Power on the system.**  
POST tests the CPU, memory, and I/O subsystems. If the problem is persistent, POST will fail the PCIe root complex test and disable the /SYS/MB/PCIE component.
4. **If POST detects the problem, replace the motherboard.**



# Communication Channel Between the Primary Domain and the Service Processor (SP) Might Hang (CR 6583567)

Rarely, a communication channel between the primary domain and the SP might hang and disable communication over the channel.

Workarounds:

- If the channel is used by a primary domain service or application other than the fault management daemon (`fmd`), for example the LDoms Manager `ldmd`, you might see warning or error messages concerning communication failures. In this case, the channel can be brought back up by restarting the affected service or application.
- If the channel is the one used by `fmd`, there are no warning or error messages. `fmd` will not receive ereports, and diagnosis of the errors does not occur.
- If the channel is the one used by the Solaris OS to communicate with the SP, you could see warning or error messages regarding failure to obtain the PRI, failure to access ASR data, or failure to set LDoms variables or failure in SNMP communication. In this case, the channel can be brought back up by resetting the SP. If the SP is reset, restart the `fmd` on the primary domain. If resetting the SP fails to bring the channel back up, then it might also be necessary to reboot the primary domain.
- If a domain crashes or a service spontaneously restarts without any associated fault messages, you must recover as follows to minimize potential loss of error telemetry.

## ▼ To Recover From a Domain Crash

1. **Restart `fmd` on the primary domain.**
2. **Wait 30 seconds.**
3. **Reset the SP with either of the following commands:**

```
-> reset /SP [ILOM CLI]  
OR  
sc> resetsc -y [ALOM CMT compatibility CLI]
```

4. **Restart `fmd` on the primary domain.**

Enter the following command from the Solaris OS:

```
# svcadm restart svc:/system/fmd:default
```

## Resetting the SP Produces Extraneous Warning Messages (CR 6585292)

The following excerpt shows the extraneous messages that should be ignored.

```
sc> resetsc [similar messages are also displayed for the reset /SP command]
...
Linux version 2.4.22 (kbellew@sanpen-rh4-0) (gcc version 3.3.4) #2 Wed
Jul 18 19:25:18 PDT 2007 r21410
Loading modules: fpga Warning: loading
/lib/modules/2.4.22/misc/fpga/fpga.o will taint the kernel: non-GPL
license - Proprietary
  See http://www.tux.org/lkml/#export-tainted for information about
tainted modules
...
Module fpga loaded, with warnings
fpga_flash Warning: loading
/lib/modules/2.4.22/misc/fpga_flash/fpga_flash.o will taint the kernel:
no license
  See http://www.tux.org/lkml/#export-tainted for information about
tainted modules
Module fpga_flash loaded, with warnings
immap Warning: loading /lib/modules/2.4.22/misc/immap/immap.o will taint
the kernel: no license
Refer to: http://www.tux.org/lkml/#export-tainted for information about
tainted modules
Module immap loaded, with warnings
...
EXT3-fs warning: maximal mount count reached, running e2fsck is
recommended
EXT3 FS 2.4-0.9.19, 19 August 2002 on tffs(100,1), internal journal
EXT3-fs: mounted filesystem with ordered data mode.
kjournald starting. Commit interval 5 seconds
EXT3-fs warning: maximal mount count reached, running e2fsck is
recommended
...
ipt_recent v0.3.1: ... < ... >. http://snowman.net/projects/ipt\_recent/
arp_tables: (C) 2002
802.1Q VLAN Support v1.8 ... < ... >
All bugs added by ...
```

## Error Messages from the Ultra320 SCSI Card

At the time of boot from a device connected with the dual-channel Ultra320 SCSI Card (SE0X7SC2F, SE0X7SC2X), the following messages may be displayed. Since these messages do not have an effect on your system behavior, ignore these messages.

```
SCSI command timeout occurred
SCSI interrupts not occur
```

## Erroneous Power Supply Faults (CR 6614432)

Some SPARC Enterprise T5120 servers report a low AC line input voltage fault when the input voltage is in the range of 90V to 94V AC. This is not the correct threshold and should not indicate an AC input fault until the voltage drops below 90V AC.

Example of erroneous fault messages:

```
sc> showlogs

Oct 09 14:13:17: Chassis |major   : "Host is running"
Oct 09 14:36:10: IPMI    |minor   : "ID = 264 : 10/09/2007 : 14:36:10 : Power
Supply : /PS1/DC_POK : State Deasserted"
Oct 09 14:36:11: IPMI    |minor   : "ID = 265 : 10/09/2007 : 14:36:11 : Power
Supply : /PS1/AC_POK : State Deasserted"
Oct 09 14:36:14: IPMI    |minor   : "ID = 266 : 10/09/2007 : 14:36:14 : Power
Supply : /PS1/FAIL  : State Asserted"
```

**Workaround:** Make sure that both server power supplies are operating. When both power supplies are operating, the server will remain powered on during and after erroneous faults.

## A Built-In Fan May be Erroneously Detected as a Failure (CR 6636098)

If a built-in fan is erroneously detected as a failure and reported as such to the Enhanced Support Facility software or Server System Manager software, the following message is displayed:

Message Example of Enhanced Support Facility:

```
FJSVmadm:A:FANBD0/FM0/F0/TACH:FJSVmadm:Detected failure on the fan
-----
(location of a built-in fan. Results may vary.)
```

Message Example of Server System Manager:

```
SSMAPL:A::FJSVapplg::status was changed. (component:"FANBD0/FM0" from "normal"
to "fatal")
-----
(location of a built-in fan. Results may vary.)
```

However, entering one of the ILOM status confirmation commands (such as the `showenvironment` command) will display the status of the system correctly. When the actual faulty in a built-in fan is detected, the following sample message is displayed.

Otherwise a built-in fan is erroneously detected as a failure and the message below is not displayed.

```
sc> showfaults
Last POST Run: Fri May 16 14:27:39 2008

Post Status: Passed all devices
ID FRU Fault
1 /SYS/FANBD0/FM0 SP detected fault: TACH at /SYS/FANBD0/FM0/F0 has
exceeded low non-recoverable threshold.
```

Workaround: Since these messages do not have an effect on your system behavior, ignore these messages. For the Enhanced Support Facility, this problem is also resolved by applying the Enhanced Support Facility Patch 914604-04. For Server System Manager, no workaround is available.

## After a Host Power-On Instruction is Executed from ILOM, the POST May Not Start, and Processing May Not Go to OS Boot Processing or the ok Prompt (CR 6752910)

After a host power-on instruction is executed from ILOM, the POST (self-diagnostics test) may not start, and processing may not go to OS boot processing or the ok Prompt for OpenBoot PROM (OBP).

[ILOM command interface operation example]

```
-> start /SYS
-> start /SP/console
Are you sure you want to start /SP/console (y/n)? y
Serial console started. To stop, type #.
```

[ALOM CMT compatibility shell operation example]

```
sc> poweron
sc> console
Enter #. to return to ALOM.
```

Nothing is displayed on the OS console. Entering the escape character "#" restores the ILOM prompt. The result of the Domain Status may vary. No power-on log item has been recorded in the event log.

showplatform command and showlogs command domain status reference example:

```
sc> showplatform
SUNW,SPARC-Enterprise-T5120

Domain Status
-----
S0      Powered off * Domain Status : "Powered on", "Powered off", "OpenBoot
initializing", "Unknown" etc.
sc>

sc> showlogs -p p

Log entries since Sep 29 12:45:39
-----
Sep 29 12:45:39: Chassis |major   : "Host has been powered on"
Sep 29 12:49:28: Chassis |major   : "Host is running"
Sep 29 12:49:43: Chassis |critical: "Host has been powered off"
```

```

Sep 29 12:50:47: Chassis |major    : "Host has been powered on"
Sep 29 12:54:35: Chassis |major    : "Host is running"
Sep 29 12:54:51: Chassis |critical: "Host has been powered off" * There is no
"Host has been powered on." log entry after this.
sc>

```

## For DC Input Power Models, /PS0/AC\_POK Is Displayed (CR 6815369)

For DC input power models, /PS0/AC\_POK and /PS0/DC\_POK identify sensors in the power supply units. /PS0/AC\_POK does not represent an AC power supply unit.

For example, the following event log is collected when the DC power cable is disconnected or reconnected:

[When the DC power cable is disconnected]

```

IPMI |minor    : "ID = 1cec : 02/06/2009 : 04:00:26 : Power Supply
: /PS0/AC_POK : State Deasserted" <-- (*)
IPMI |minor    : "ID = 1ced : 02/06/2009 : 04:00:26 : Power Supply
: /PS0/DC_POK : State Deasserted"
IPMI |minor    : "ID = 1cee : 02/06/2009 : 04:00:26 : Power Supply
: /PS0/FAIL  : State Asserted"

```

[When the DC power cable is reconnected]

```

IPMI |minor    : "ID = 1cef : 02/06/2009 : 04:00:59 : Power Supply
: /PS0/AC_POK : State Asserted" <-- (*)
IPMI |minor    : "ID = 1cf0 : 02/06/2009 : 04:00:59 : Power Supply
: /PS0/DC_POK : State Asserted"
IPMI |minor    : "ID = 1cf1 : 02/06/2009 : 04:00:59 : Power Supply
: /PS0/FAIL  : State Deasserted"

```

Workaround: None

## According to the IPMI PET Warning and SNMP Trap Warning Settings in the Warning Rule Settings, Warning Message Creation may not be Possible Depending on the Event Type (CR 6746677)

According to the IPMI PET warning and SNMP trap warning settings in the warning rule settings, warning message creation may not be possible depending on the event type, irrespective of the warning level.

Execution example:

- "/SYS/MB/component name Disabled by CLI action." or "/SYS/MB/component name Disabled by user" (critical) is reported with an IPMI PET warning when a component is disabled by the `set /SYS/component-name component_state=disabled` command or `disablecomponent` command, respectively.
- "Host has been powered on" (major) is not reported with an IPMI PET warning or SNMP trap warning when the power to the host is turned on.
- "/SYS/MB/FT\* has exceeded low non-recoverable threshold." (critical) is not reported when the fan speed of a built-in fan falls below the threshold value.
- "ERROR: POST errors detected" (major) is not reported with an IPMI PET warning or SNMP trap warning when an error is detected in a POST (self-diagnostics test).

## In the Logical Domains Environment, After the Host Reset Operation, Host May Be Reset Again (CR 6836426)

In the Logical Domains environment, after the host reset operation, host may be reset again.

Example:

```
sc> reset -c -y
Reset | major: Reset of /SYS initiated by alom.
Reset | major: Reset of /SYS by alom succeeded.
Performing reset on the system

Enter #. to return to ALOM.

SPARC Enterprise T5220, No Keyboard
Copyright 2009 Sun Microsystems, Inc. All rights reserved.
OpenBoot 4.30.2.build_06***PROTOTYPE BUILD***, 2048 MB memory
available, Serial #XXXXXXX.
Ethernet address XX:XX:XX:XX:XX:XX, Host ID: XXXXXXXX.
:
:
host1 console login: Chassis | critical: Host has been reset
:
SPARC Enterprise T5220, No Keyboard
Copyright 2009 Sun Microsystems, Inc. All rights reserved.
OpenBoot 4.30.2.build_06***PROTOTYPE BUILD***, 2048 MB memory
available, Serial #XXXXXXXXX.
Ethernet address XX:XX:XX:XX:XX:XX, Host ID: XXXXXXXX.
:
:
host1 console login:
```

Workaround: None. The second reset has no impact on the system.



## The ILOM Network Configuration Cannot Be Set (CR 6835854, 6779753)

In case that the NET-MGT port of ILOM has not been connected with the LAN cable and the network gateway is not set, the ILOM network configuration cannot be set.

Output example when the settings cannot be applied:

```
-> set /SP/network/ pendingipdiscovery=static
Set 'pendingipdiscovery' to 'static'

-> set /SP/network/ pendingipaddress=192.9.200.33
Set 'pendingipaddress' to '192.9.200.33'

-> set /SP/network/ pendingipnetmask=255.255.255.0
Set 'pendingipnetmask' to '255.255.255.0'

-> set /SP/network/ commitpending=true
set: Unable to get network management property

->
-> show /SP/network/ -d properties
/SP/network
Properties:
    commitpending = (Cannot show property)
    dhcp_server_ip = none
    ipaddress = (none)
    ipdiscovery = (none)
    ipgateway = (none)
    ipnetmask = (none)
    macaddress = (none)
    pendingipaddress = 192.9.200.33
    pendingipdiscovery = static
    pendingipgateway = (none)
    pendingipnetmask = 255.255.255.0
    state = disabled
```

Workaround: None. Connect the LAN cable to the NET-MGT port of ILOM and then set the network configuration.

## An Error is Registered with the showfaults Command When Running POST, But POST Ends Normally (CR 11210193)

If an error occurs during POST execution, "Fault Sensor VCORE\_POK at /SYS/MB deasserted" may be registered when the showfaults ALOM CMT compatibility command is used for status confirmation. However, POST will still end normally in this case.

```
sc> showfaults -v
Last POST Run: Sun Apr 20 17:53:36 2008

Post Status: Passed all devices
  ID Time           FRU      Class  Fault
  1 Apr 19 06:41:14 /SYS/MB      SP detected fault: Fault Sensor
VCORE_POK at /SYS/MB
deasserted
sc>
```

Workaround: None. If this problem occurs, use the resetsc ALOM CMT compatibility command to clear the log and reset the LED display.

## The ok Prompt is Not Displayed After POST Ends (CR 11215994)

In rare circumstances, the ok prompt may not be displayed normally after POST execution ends.

Workaround: If this problem occurs, use the `showfaults -v ALOM CMT` compatibility command to confirm the status of POST. When the "Last POST Run" displays the date and time of the POST currently executed and "POST Status" shows "Passed all devices," this indicates that the POST completed normally. Execute the `resetsc ALOM CMT` compatibility command, and then execute the `poweroff` and `poweron` ALOM CMT compatibility commands, in this order.

```
2008-04-29 17:10:35.407 0:0:0>.....
2008-04-29 17:10:57.749 0:0:0>End   : Block Mem Test
2008-04-29 17:10:57.757 0:0:0>INFO:
2008-04-29 17:10:57.766 0:0:0> POST Passed all devices.
2008-04-29 17:10:57.783 0:0:0>POST:      Return to VBSC.
2008-04-29 17:10:57.795 0:0:0>Master set ACK for vbosc runpost
command and spin...
/
sc>
sc> showfaults -v
Last POST Run: Tue Apr 29 17:10:58 2008

Post Status: Passed all devices
No failures found in System
sc>
```

---

# Solaris OS Issues

[TABLE 3-4](#) lists the late-breaking issues related to the running the Solaris OS on the SPARC Enterprise T5120 and T5220 servers. Additional information for some of the issues is provided following the table.

---

**Note** – Additionally, more general Solaris OS late-breaking issues are described in the Solaris 10 Release Notes.

---

**TABLE 3-4** Solaris OS Issues

CR	Description	Workaround
6519290	Large amounts of I/O on swap devices might cause the system to appear hangup by overwelling the I/O system.	The amount of I/O required may be generated through a number of ways: memory shortage, heavy use of /tmp etc. Set the following to /etc/system and then reboot the Solaris OS. set maxfastscan=0x2000
6564180	The Solaris OS locator command does not work on this server.	Instead, use either the ILOM or ALOM CMT compatibility locator command as follows: <ul style="list-style-type: none"><li>• From the ILOM CLI: -&gt; <b>show /SYS/LOCATE/</b> -&gt; <b>show /SYS/LOCATE/ value=off</b> -&gt; <b>show /SYS/LOCATE/ value=on</b></li><li>• From the ALOM CMT compatibility CLI: sc&gt; <b>showlocator</b> sc&gt; <b>setlocator on</b> sc&gt; <b>setlocator off</b></li></ul>
6587380	The Solaris prtdiag -v command displays non-voltage information in the voltage indicator section.	Be aware that the voltage and nonvoltage information (such as PS0/TEMP_FAULT) is accurate and represents the current condition of the components.

---

**TABLE 3-4** Solaris OS Issues (*Continued*)

CR	Description	Workaround
6373437 (6588499)	<p>A Solaris OS shutdown might hang and result in fewer system services.</p> <p>Rarely, a shutdown performed immediately after the Solaris OS boots might cause the system to hang because some system services are attempting to stop while others are still in the process of starting. The hang occurs with a message similar to the following:</p> <pre>svc.startd: The system is coming down. Please wait svc.startd: 74 system services are now being stopped</pre>	<p>Reboot the system by dropping to the service processor (SP). Then power cycle the host system using one of the following methods:</p> <ul style="list-style-type: none"> <li>• From the ILOM CLI: <ul style="list-style-type: none"> <li>-&gt; <b>stop /SYS</b></li> <li>-&gt; <b>start /SYS</b></li> </ul> </li> <li>• From the ALOM CMT compatibility CLI: <pre>sc&gt; <b>poweroff</b> sc&gt; <b>poweron</b> sc&gt; <b>powercycle</b></pre> </li> </ul>
6607315	<p>The login prompt resets five seconds after the Solaris OS boots.</p> <p>This only occurs when using a local keyboard as the input device (<code>input-device=keyboard</code>). This issue does not occur with the virtual-console.</p>	Use the virtual console as the input device.
n/a	The output of the <code>raidctl -h</code> command and the <code>raidctl</code> man page display some unsupported features.	The SPARC Enterprise T5120 and T5220 servers currently only support RAID 0 and RAID 1 for the o-board SAS disk controller. The <code>raidctl</code> utility can be used to create and delete RAID 0 & RAID 1 volumes. Refer to the <i>SPARC Enterprise T5120 and T5220 Servers Administration Guide</i> for supported RAID information.
6617544	The <code>prtdiag</code> command doesn't display the <code>fjgi</code> information of Fujitsu-manufactured card	None.
6617549	In times such as PSU failure, OS outputs the message; however, the last one character is not displayed.	None.
6722640	<p>Messages similar to the following might be displayed during boot. You might not be able to get some sensor information when using SNMP.</p> <pre>picld[xxx]: PICL snmpplugin: sunPlatSensorClass 0 unsupported</pre>	This problem has no effect on your server when not using SNMP.
6718841	Sun Explorer may fail to collect the ILOM data (Tx000). If failed, it may take more than 30 minutes to return an error.	<p>You can collect the ILOM data (Tx000) in another way.</p> <p>For details, see <a href="#">“Sun Explorer May Fail to Collect the ILOM Data (Tx000) (CR 6718841)” on page 59.</a></p>

**TABLE 3-4** Solaris OS Issues (*Continued*)

CR	Description	Workaround
6836653	<p>USB SATA DVD drive is not supported for the following versions of the Solaris OS:</p> <ul style="list-style-type: none"><li>• Solaris 10 8/07 OS</li><li>• Solaris 10 5/08 OS</li></ul> <p><b>Note</b> - USB SATA DVD drive is supported for the later versions of the Solaris 10 OS, beginning with Solaris 10 10/08 OS.</p>	<p>To install Solaris 10 8/07 OS or Solaris 10 5/08 OS on a server equipped with a USB SATA DVD drive, install the OS from the install server and apply the mandatory patches, the latest periodic PTF, and the latest recommended security patches.</p> <p>For the installation procedures, see <a href="#">“Notes on Installing Solaris 10 8/07 OS and Solaris 10 5/08 OS”</a> on page 60.</p> <p>For servers shipped after September 2009, the USB SATA DVD drive unit has been mounted. Confirm whether a USB SATA DVD drive unit is mounted on your server by using either of the following methods.</p> <ul style="list-style-type: none"><li>• Confirm that the "SATA DVD" mark appears on the front side of the DVD drive.</li><li>• Confirm that specific part numbers are displayed in the output for the following ILOM/ALOM commands.</li></ul> <p>[Confirm by using ILOM command]</p> <p>Confirm whether either of the following part numbers is displayed in the output from <code>ls /SYS/PADCRD</code> command.</p> <pre>fru_part_number = 5413512 or fru_part_number = 5413513</pre> <p>[Confirm by using ALOM command]</p> <p>Confirm whether either of the following part numbers is displayed in the output from <code>showfru /SYS/PADCRD</code> command.</p> <pre>/Partner_Part_NumberR/Partner_Part_Nu mber: CF005413512REVxx or /Partner_Part_NumberR/Partner_Part_Nu mber: CF005413513REVxx</pre>

# Sun Explorer May Fail to Collect the ILOM Data (Tx000) (CR 6718841)

Sun Explorer may fail to collect the ILOM data (Tx000).  
If failed, it may take more than 30 minutes to return an error.

Workaround: You can collect the ILOM data (Tx000) in another way.

## 1. Specify the option as follows.

```
# /opt/SUNWexplo/bin/explorer -w !Tx000
```

## 2. Confirm the version of ILOM.

Depending on the version of ILOM, the data collection method varies.

### ■ How to check the version

- ILOM mode

```
-> version  
SP firmware 3.0.3.20.c  
      ~ <-- ILOM3.0  
SP firmware build number: 45383  
SP firmware date: Tue Jun  2 15:38:58 PDT 2009  
SP filesystem version: 0.1.22  
  
->
```

- ALOM mode

```
sc> showsc version  
SP firmware version: 3.0.3.20.c  
      ~ <-- ILOM3.0  
  
sc>
```

## 3. Collect the ILOM data (Tx000).

### ■ In ILOM 3.0 or later

In the Integrated Lights Out Manager (ILOM) 3.0 Concepts Guide, refer to the "Collect SP Data to Diagnose System Problems" section to collect the SP data information.

### ■ In ILOM 2.x or earlier

Collect the ILOM and ALOM data and supply it to service engineers along with the Sun Explorer output.

#### a. Collect the following data on ILOM.

```
show /SP/users
show /SP/users/admin
show /HOST
```

**b. Create an ALOM compatible user and collect the following data on ALOM.**

```
consolehistory -v
showcomponent
showdate
showenvironment
showfaults -v
showfru
showhost
showkeyswitch
showlogs -v -g 0 -p p

shownetwork
showplatform -v
showsc
showsc version -v
showusers
```

**c. Reset ILOM.**

```
-> reset /SP
Are you sure you want to reset /SP (y/n)? y
Performing hard reset on /SP
```

## Notes on Installing Solaris 10 8/07 OS and Solaris 10 5/08 OS

USB SATA DVD drive is not supported for the Solaris 10 8/07 OS and Solaris 10 5/08 OS.

To install Solaris 10 8/07 OS or Solaris 10 5/08 OS on a server equipped with a USB SATA DVD drive, install the OS from the install server and apply the mandatory patches, the latest periodic PTF, and the latest recommended security patches.



The procedure is shown below.

### 1. Create an install image on the install server.

Example:

This example assumes the DVD medium has been mounted to '/cdmnt'.

```
# mkdir -p /export/home/dvd
# cd /cdmnt/Solaris_10/Tools
# ./setup_install_server /export/home/dvd
# share |grep /export/home/dvd
# share -F nfs -o ro,anon=0 -d "install server directory" /export/home/dvd
# svcs -l svc:/network/nfs/server:default
# svcadm enable svc:/network/nfs/server
# shareall
# cd /
# eject cdrom
```

### 2. Install the OS from the install server.

### 3. Apply the latest periodic PTF and the latest recommended security patches.

The mandatory patches which are described in the [“Mandatory Patch Information” on page 22](#) are collected into the periodic PTF R08111 or later. From the viewpoint of preventive maintenance, apply the latest periodic PTF and the latest recommended security patches.

To apply the minimum mandatory patches only, apply the patches in the following order.

- In case of Solaris 10 8/07 OS

```
# LANG=C;export LANG
# patchadd 119254-51
# patchadd 125891-01
# patchadd 127755-01
# patchadd 127127-11
```

- In case of Solaris 10 5/08 OS

There are no mandatory patches.

### 4. Restart the OS.

```
# shutdown -i6 -g0 -y
```

---

# LDoms Related Issues

[TABLE 3-5](#) lists the late-breaking LDoms related issues. Additional information for some of the issues is provided following the table.

**TABLE 3-5** LDoms Related Issues

<b>CR</b>	<b>Description</b>	<b>Workaround</b>
6540368	In Logical Domains 1.0.1 software, there are a few cases where variable updates do not persist.	For more information, refer to the <i>Logical Domains (LDoms) 1.0.1 Release Notes</i> .
6597815	XAUI and CPU resources added after initial LDoms Setup are not available to LDoms Manager.	When you add CPU or XAUI resources to a server configured to use logical domains, you must revert to the factory default configuration to allow the LDoms Manager software to allocate those resources to guest domains.

## Documentation Errata

---

This chapter describes known errors and corrections to the SPARC Enterprise T5120 and T5220 server documentation.

- ["SPARC Enterprise T5120 and T5220 Servers Site Planning Guide"](#) on page 63
- ["SPARC Enterprise T5120 and T5220 Servers Installation Guide"](#) on page 68
- ["SPARC Enterprise T5120 and T5220 Servers Service Manual"](#) on page 68
- ["SPARC Enterprise T5120 and T5220 Servers Administration Guide"](#) on page 71
- ["Integrated Lights Out Manager 2.0 User's Guide"](#) on page 71
- ["Integrated Lights Out Manager 2.0 Supplement for the SPARC Enterprise T5120 and T5220 Servers"](#) on page 72
- ["Integrated Lights Out Manager \(ILOM\) 3.0 CLI Procedures Guide"](#) on page 73
- ["Integrated Lights Out Manager 3.0 Supplement for SPARC Enterprise T5120 and T5220 Servers"](#) on page 74

---

### *SPARC Enterprise T5120 and T5220 Servers Site Planning Guide*

#### Error on page 2 in "Minimum Clearance for Service Access"

The text in "Minimum Clearance for Service Access" on page 2 contains an error.

The correct text is as follows:

The SPARC Enterprise T5120/T5220 servers require physical access from the top for maintenance. Therefore, a stepladder may be required depending on which rack the server is installed in. And it may be necessary to remove the server from the rack depending on the component to be replaced.

The minimum clearance for service access varies depending on whether a stepladder is used. Secure an appropriate clearance for service access before starting maintenance.

This section shows the minimum clearance for service access premised on the standard maintenance work of our company. If this minimum clearance cannot be secured, contact our field engineer.

No stepladder is required if this server is installed at the 20U level or lower. A stepladder is required if it is installed at the 21U level or higher. [FIGURE 1](#) shows the minimum clearance for service access required for either server.

**FIGURE 1** Minimum Clearance for Service Access

1. If the server is installed at the 20U level or lower (\*1): (\*1 Judged based on the level of the equipment top)

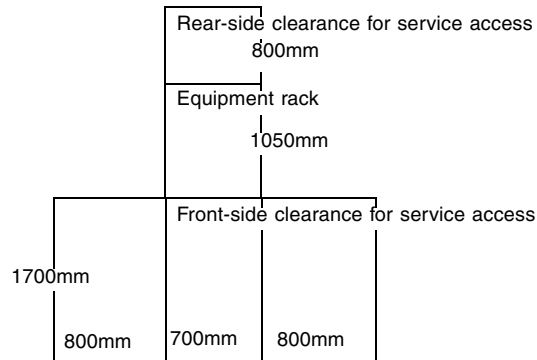

2. If the server is installed at a level between 21U and 40U (\*1): (\*1 Judged based on the level of the equipment top)

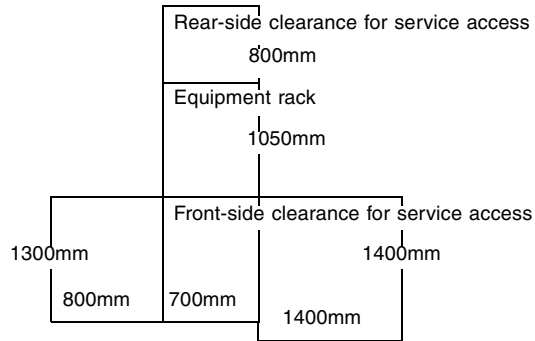

## Incorrect Values for the 1.6 GHz SpecJBB Test

Tables 5, 7, and 8 of the Site Planning Guide contain incorrect values for the peak input power when running SpecJBB in a system with 1.6 GHz CPUs and a maximum memory, HDD, and PCIe card configuration. The following tables provide the correct values.

Table 5: SPARC Enterprise T5120 Server (4-Disk Capable) Power Specifications

<b>Maximum Server Configuration Specifications</b>				
<b>8 core, 1.6 GHz processor, with sixteen 4 GB FBDIMMs, 4 HDDs, 3 PCIe I/O cards</b>				
	Incorrect Value (AC Input)	Correct Value (AC Input)	Incorrect Value (DC Input)	Correct Value (DC Input)
Peak input power running SpecJBB	615.3 W	624.3W	574.7 W	583.1W

Table 7: SPARC Enterprise T5220 Server (8-Disk Capable) Power Specifications

<b>Maximum Server Configuration Specifications</b>				
<b>8 core, 1.6 GHz processor, with sixteen 4 GB FBDIMMs, 8HDDs, 6 PCIe I/O cards</b>				
	Incorrect Value (AC Input)	Correct Value (AC Input)	Incorrect Value (DC Input)	Correct Value (DC Input)
Peak input power running SpecJBB	807.4 W	814.4W	754.1 W	760.7W

Table 8: SPARC Enterprise T5220 Server (16-Disk Capable) Power Specifications

<b>Maximum Server Configuration Specifications</b>				
<b>8 core, 1.6 GHz processor, with sixteen 4 GB FBDIMMs, 16 HDDs, 6 PCIe I/O cards</b>				
	Incorrect Value (AC Input)	Correct Value (AC Input)	Incorrect Value (DC Input)	Correct Value (DC Input)
Peak input power running SpecJBB	901.5 W	908.5W	842.0 W	848.6W

## Incorrect Idle Input Power Values

Four tables in the *SPARC Enterprise T5120 and T5220 Site Planning Guide* contain incorrect values for the idle input power. The following four tables show the correct information for those tables:

Table 5: SPARC Enterprise T5120 Server (4-Disk Capable) Power Specifications

---

<b>Minimum Server Configuration Specifications</b>				
<b>4 core, 1.2 GHz processor, with four 1 GB FBDIMMs, no HDDs, no PCIe I/O cards</b>				
	Incorrect Value (AC Input)	Correct Value (AC Input)	Incorrect Value (DC Input)	Correct Value (DC Input)
Idle input power	187.0 W	179.0 W	174.7 W	167.2 W

---

Table 6: SPARC Enterprise T5120 Server (8-Disk Capable) Power Specifications

---

<b>Minimum Server Configuration Specifications</b>				
<b>4 core, 1.2 GHz processor, with four 1 GB FBDIMMs, no HDDs, no PCIe I/O cards</b>				
	Incorrect Value (AC Input)	Correct Value (AC Input)	Incorrect Value (DC Input)	Correct Value (DC Input)
Idle input power	187.0 W	179.0 W	174.7 W	167.2 W

---

Table 7: SPARC Enterprise T5220 Server (8-Disk Capable) Power Specifications

---

<b>Minimum Server Configuration Specifications</b>				
<b>4 core, 1.2 GHz processor, with four 1 GB FBDIMMs, no HDDs, no PCIe I/O cards</b>				
	Incorrect Value (AC Input)	Correct Value (AC Input)	Incorrect Value (DC Input)	Correct Value (DC Input)
Idle input power	194.0 W	186.0 W	181.2 W	173.7 W

---

Table 8: SPARC Enterprise T5220 Server (16-Disk Capable) Power Specifications

---

<b>Minimum Server Configuration Specifications</b>				
<b>4 core, 1.2 GHz processor, with four 1 GB FBDIMMs, no HDDs, no PCIe I/O cards</b>				
	Incorrect Value (AC Input)	Correct Value (AC Input)	Incorrect Value (DC Input)	Correct Value (DC Input)
Idle input power	194.0 W	186.0 W	181.2 W	173.7 W

---

---

## *SPARC Enterprise T5120 and T5220 Servers Installation Guide*

This manual includes descriptions using the cable management arm (CMA); however, the SPARC Enterprise T5120 server doesn't support the cable management arm.

### Verify Proper Seating of Preinstalled PCIe/XAUI Cards

The server installation procedure should include instructions for verifying that any preinstalled PCIe and/or XAUI cards and their risers have not worked loose during shipping. This procedure should also include instructions for verifying that internal cables are properly routed and that their connections are secure.

Workaround: When installing a newly arrived server that has preinstalled PCIe and/or XAUI cards, open it and verify that the cards and their risers are securely seated. Also verify that the internal cables are correctly routed and securely connected. Refer to the *SPARC Enterprise T5120 and T5220 Servers Service Manual* for information about the PCIe/XAUI cards and their risers as well as information about internal cable routing.

---

## *SPARC Enterprise T5120 and T5220 Servers Service Manual*

### Erroneous Description in the Section "Disconnect Power Cords From the Server"

The following description in the section "Disconnect Power Cords From the Server" is incorrect.

- Unplug all power cords from the server.



---

**Caution** – Because 3.3v standby power is always present in the system, you must unplug the power cords before accessing any cold-serviceable components.

---



The correct information is as follows:

- For AC models – Unplug all power cords from the server.
- For DC models – Turn off the power at the power source circuit breaker.



---

**Caution** – When power is applied to the server (even when the host is powered off) the 3.3v standby power is present in the system, so you must remove power before accessing any cold-serviceable components.

---

## Erroneous Description in the Section "Removing the Air Duct" on page 101

The following description in the section "Removing the Air Duct" on page 101 is incorrect.

3. (SPARC Enterprise T5120 server; 8 drive-capable) Disconnect and stow the hard drive data cable.
  - d. Route the hard drive data cable over the fan module and along the air duct.
  - e. Plug the data cable into J6401 on the motherboard.

The correct information is as follows:

3. (SPARC Enterprise T5120 server, 8-HDD model) Disconnect and stow the hard drive data cable.
  - a. Unplug the hard drive data cable from J6401 on the motherboard.
  - b. Remove the hard drive data cable from its seat on the CPU air duct.
  - c. Place the hard drive cable end out of the way of the air duct.

## Erroneous Description in "Fan Module Configurations for SPARC Enterprise T5220 Servers (8- and 16-Disk Capable)"

The description in the section "Fan Module Configurations for SPARC Enterprise T5220 Servers (8- and 16-Disk Capable)" is incorrect. The fan module configurations are different between 8-disk capable and 16-disk capable servers. The correct configurations are as follows:

**TABLE:** SPARC Enterprise T5220 (8 Hard Drive Capable) Fan Module Locations and FRU Names

(Empty)	(Empty)	(Empty)
/SYS/FANBD0/FM0	/SYS/FANBD0/FM1	/SYS/FANBD0/FM2
Front of system		

**TABLE:** SPARC Enterprise T5220 (16 Hard Drive Capable) Fan Module Locations and FRU Names

(Empty)	/SYS/FANBD1/FM1	(Empty)
/SYS/FANBD0/FM0	/SYS/FANBD0/FM1	/SYS/FANBD0/FM2
Front of system		

## Unnecessary Procedure in "Install the Hard Drive Cage"

The following procedure in "Install the Hard Drive Cage" is unnecessary and can be ignored.

### 3. (SPARC Enterprise T5120 server, 8 disk-capable) Remove fan FM1.

## Incorrect FRU Name is Specified in the TABLE: Motherboard Components (SPARC Enterprise T5120 Servers)

The FRU Name of /SYS/MB/SC/SCC\_NVRAM should be /SYS/MB/SCC\_NVRAM.

## Incorrect FRU Name is Specified in the TABLE: Motherboard Components (SPARC Enterprise T5220 Servers)

The FRU Name of /SYS/MB/SC/SCC\_NVRAM should be  
/SYS/MB/SCC\_NVRAM.

---

## *SPARC Enterprise T5120 and T5220 Servers Administration Guide*

### Notes on the "SPARC Enterprise T5x20 Device Tree"

The device tree of the DVD drive indicated on page 39 is not supported for the servers shipped after September 2009. The correct tree is as follows:

- For the servers shipped after September 2009

```
/pci@0/pci@0/pci@1/pci@0/pci@1/pci@0/usb@0,2/hub@4/device@4/storage@  
0/disk
```

---

## *Integrated Lights Out Manager 2.0 User's Guide*

### Incorrect ILOM Command Related to IP Address Assignment

The ILOM commands indicated on page 23 and page 28 include erroneous information.

```
setpendingipdiscovery= should be set pendingipdiscovery=.
```

## The Command in the Section "Edit an SNMP User Account Using the CLI" on Page 195 is Incorrect

The following command described is incorrect.

```
edit /SP/services/snmp/users/username authenticationpassword=  
password
```

To edit an SNMP v3 user account, type the following command:

```
set /SP/services/snmp/users/username authenticationpassword=  
password
```

---

## *Integrated Lights Out Manager 2.0 Supplement for the SPARC Enterprise T5120 and T5220 Servers*

### Points of Concern about the Connection of ILOM (CR 6806789)

On the SPARC Enterprise T5120 and T5220 servers, ILOM supports a maximum of 5 active sessions, including serial, Secure Shell (SSH), and web interface sessions.

### About ALOM CMT Shell Command

This manual focuses on the basic usage of the ALOM CMT compatibility shell command. For details of the ALOM CMT shell command, see "Advanced Lights Out Management (ALOM) CMT v1.x Guide" (C120-E386).

---

# Integrated Lights Out Manager (iLOM) 3.0 CLI Procedures Guide

## Erroneous Description in "Collect SP Data to Diagnose System Problems" (CR 6806800)

The following description in the section "Collect SP Data to Diagnose System Problems" on page 88 includes incorrect information.

Variable	Option	Description
<i>URI</i>	Any valid target directory location	Specifies the URI of the target directory. The URI format is as follows: <code>protocol://username:password@host/directory</code> Where protocol can be one of these transfer methods: SFTP, TFTP, or FTP. For example, to store the snapshot information in the directory named <code>data</code> on the host, define the <i>URI</i> as follows: <code>ftp://joe:mypasswd@host_ip_address/data</code> The directory <code>data</code> is relative to the user's login, so the directory would probably be <code>/home/joe/data</code> .

Service Snapshot utility does not support the SP data collection using TFTP.

## Erroneous Default Value for `/SP/clients/dns`

The default value for `/SP/clients/dns` indicated on page 29 and page 144 is incorrect. The correct value is "enabled."

---

# *Integrated Lights Out Manager 3.0 Supplement for SPARC Enterprise T5120 and T5220 Servers*

## Notes on "ILOM Information Stored on the SCC"

When transferring the SCC to the replacement server, keep the following note in mind.

---

**Note** – If the ILOM versions are different between the failed server and the replacement server, the settings on the SCC(NVRAM) will be ignored or overwritten. If the ILOM versions are the same, the settings will be retained.

---

## Fixed Issues

This appendix describes the fixed issues concerning the SPARC Enterprise T5120 and T5220 servers. You can avoid the issues by using the latest version of Solaris OS, System Firmware, or other software. For details on the fix, see the "workaround" in each table.

- ["Hardware and Mechanical Issues" on page 75](#)
- ["Ethernet Interface Related Issues" on page 77](#)
- ["Firmware, ILOM, POST, and SP Issues" on page 84](#)
- ["Solaris OS Issues" on page 118](#)
- ["LDoms Related Issues" on page 128](#)

---

## Hardware and Mechanical Issues

[TABLE A-1](#) lists the hardware and mechanical issues that have been fixed.

**TABLE A-1** Fixed Hardware and Mechanical Issues

CR	Description	Workaround
6592272	An uncorrectable L2 writeback error might generate a memory fault message (SUN4V-8000-E2) to the console.	<p><b>Note - Fixed in the Solaris 10 5/08 OS (and later) and in the Solaris 10 8/07 OS with patch ID 127127-11 or later installed.</b></p> <p>See <a href="#">"L2 Cache Errors Might Generate an Erroneous Memory Fault (CR 6592272)" on page 76.</a></p> <p>You can also upgrade the OS or install the patch to avoid encountering this issue.</p>

**TABLE A-1** Fixed Hardware and Mechanical Issues (*Continued*)

CR	Description	Workaround
6616209 6617012	A power supply fan failure might not generate a fault.  Note - This issue only applies to fan failures in power supply 0. A fan failure in power supply 1 will generate a fault.	<b>Note - Fixed in System Firmware 7.0.9 or later.</b> To ensure continuous operation during a possible power supply fan fault, ensure that both power supplies are connected to two separate power circuits.

## L2 Cache Errors Might Generate an Erroneous Memory Fault (CR 6592272)

This issue is resolved for servers running the Solaris 10 5/08 OS and later. If you are running Solaris 10 8/07, you can fix this issue with patch ID 127127-11 or later.

In earlier versions, the issue shows up after an uncorrectable L2 writeback error. A bogus memory fault message (SUN4V-8000-E2) might be reported to the console. Example:

```
SUNW-MSG-ID: SUN4V-8000-E2, TYPE: Fault, VER: 1, SEVERITY: Critical
EVENT-TIME: Wed Sep  5 18:49:35 EDT 2007
PLATFORM: SUNW,SPARC-Enterprise-T5220, CSN: -, HOSTNAME: wgs48-100
SOURCE: cpumem-diagnosis, REV: 1.6
EVENT-ID: 59bf6418-5dcb-c1b0-b06a-f26fa18e4ee7
DESC: The number of errors associated with this memory module has
exceeded acceptable levels. Refer to http://sun.com/msg/SUN4V-
8000-E2
for more information.
AUTO-RESPONSE: Pages of memory associated with this memory module
are
being removed from service as errors are reported.
IMPACT: Total system memory capacity will be reduced as pages are
retired.
```

Workaround: Use `fmddump -eV -u uuid` with the UUID from the console message to determine if the memory error is bogus. For example:

```
# fmddump -eV -u 59bf6418-5dcb-c1b0-b06a-f26fa18e4ee7 | grep dram-esr
dram-esr = 0x1000000000008221
```

If the dram-esr is 0x1000000000008221, this CR 6592272 has been encountered, and the memory error can be ignored. No memory component replacement is necessary. Use `fmadm repair uuid` to repair the bogus memory error.



If the `dram-esr` is different, schedule a repair procedure to replace the affected memory module. Use `fmddump -v -u event_id` to identify the module.

---

## Ethernet Interface Related Issues

TABLE A-2 lists the Ethernet related issues that have been fixed.

**TABLE A-2** Fixed Ethernet Related Issues

CR	Description	Workaround
6551509	If you run <code>modunload</code> while the <code>nxge</code> port is running, a system panic might occur.	<p><b>Note - Fixed in the Solaris 10 5/08 OS (and later) and in the Solaris 10 8/07 OS with patch ID 127127-11 or later installed.</b></p> <p>Unplumb the interfaces prior to unloading the driver. See <a href="#">“Using modunload While the nxge Port Is Running, Could Cause a System Panic (CR 6551509)”</a> on page 78.</p> <p>You can also upgrade the OS or install the patch to avoid encountering this issue.</p>
6554478	Receiving Jumbo Frames might drop the Ethernet interface to 30 Mbps due to packet dropping.	<p><b>Note - Fixed in the Solaris 10 5/08 OS (and later) and in the Solaris 10 8/07 OS with patch ID 127127-11 or later installed.</b></p> <p>Set the MTU size to 8172 as described in <a href="#">“Jumbo Frames Throughput of nxge Drops to 30 Mbps Due to Packet Dropping (CR 6554478)”</a> on page 80.</p> <p>You can also upgrade the OS or install the patch to avoid encountering this issue.</p>
6561389	Setting properties for the network interface unit (NIU) <code>nxge</code> devices could fail. For an example of the failure, see <a href="#">“Setting Properties for nxge Devices Might Fail (CR 6561389)”</a> on page 82.	<p><b>Note - Fixed in the Solaris 10 5/08 OS (and later) and in the Solaris 10 8/07 OS with patch ID 127127-11 or later installed.</b></p> <p>Use the global declaration without the device path in the <code>nxge.conf</code> file. For example, add the following line to the <code>nxge.conf</code> file:</p> <pre>accept_jumbo = 1;</pre> <p>You can also upgrade the OS or install the patch to avoid encountering this issue.</p>

**TABLE A-2** Fixed Ethernet Related Issues (*Continued*)

CR	Description	Workaround
6567838	<p>The server might panic in <code>nxge_start</code> when the <code>dupb</code> fails.</p> <p>If Jumbo Frames are enabled, the system might panic as a result of a NULL pointer reference. This scenario is only possible when frame sizes are larger than 4076. Jumbo Frames with MTU=9194 do not experience this problem.</p> <p>Note - This scenario is rare, and only occurs with frame sizes larger than 4076.</p>	<p><b>Note - Fixed in the Solaris 10 5/08 OS (and later) and in the Solaris 10 8/07 OS with patch ID 127127-11 or later installed.</b></p> <p>Disable the use of Jumbo Frames, but be aware that doing so impacts system performance. You should only apply the workarounds if your server is experiencing this problem. For details on this workaround, see <a href="#">“Server Might Panic in <code>nxge_start</code> When <code>dupb</code> Fails (CR 6567838)” on page 82.</a></p> <p>You can also upgrade the OS or install the patch to avoid encountering this issue.</p>
6599334	<p>XAUI interfaces might not be disabled when they should be disabled.</p> <p>Normally, when a CPU network interface unit (NIU) is disabled (either through POST detected faults or manually), the corresponding XAUI interface (if one is installed) should also be disabled, but that does not happen.</p>	<p><b>Note - Fixed in System Firmware 7.1.6.d or later.</b></p> <p>You can also update the System Firmware to the latest version to avoid encountering this issue.</p>
6599105	<p>Jumbo does not work for packets larger than 8144 bytes when <code>bcopy</code> is forced.</p>	<p><b>Note - Fixed in the Solaris 10 5/08 OS (and later) and in the Solaris 10 8/07 OS with patch ID 127127-11 or later installed.</b></p> <p>You can also upgrade the OS or install the patch to avoid encountering this issue.</p>

## Using `modunload` While the `nxge` Port Is Running, Could Cause a System Panic (CR 6551509)

This issue is resolved for servers running the Solaris 10 5/08 OS and later. If you are running Solaris 10 8/07, you can fix this issue with patch ID 127127-11 or later.

If you run the `modunload` command on the `nxge` driver while it is running, the system could panic. Due to an issue in the `nxge` driver, it is possible, though very unlikely, that the `nxge` driver could cause a panic during a system reboot. This panic occurs if the system is still transferring substantial amounts of network data over an `nxge` interface while the system is shutting down. It is very unlikely that this condition will occur in normal circumstances.

The panic message is `mutex_enter: bad mutex, ...`

The panic stack will include the two `nxge` driver functions `nxge_freeb()` and `nxge_post_page()`.

If such a panic occurs, the system will recover, and continue to reboot normally. The system, including the `nxge` interfaces, will come back up with no further panics.

Workaround: Unplumb the interfaces prior to unloading the driver.

## ▼ To Unplumb the Interfaces Prior to Unloading the Driver

It is usually not necessary to unload a driver from a running kernel. In those rare cases where it might be called for, you must unplumb all driver instances prior to unloading the driver.

1. Find out which `nxge` instances are plumbed (active) using the `ifconfig` command:

```
# ifconfig -a
lo0: flags=2001000849<UP,LOOPBACK,RUNNING,MULTICAST,IPv4,VIRTUAL>
mtu 8232 index 1
  inet 127.0.0.1 netmask ff000000
bge0: flags=201000843<UP,BROADCAST,RUNNING,MULTICAST,IPv4,CoS>
mtu 1500 index 2
  inet 129.153.54.82 netmask ffffffff broadcast 129.153.54.255
  ether 0:14:4f:2a:9f:6a
nxge2: flags=201000843<UP,BROADCAST,RUNNING,MULTICAST,IPv4,CoS>
mtu 1500 index 19
  inet 129.153.54.175 netmask ffffffff broadcast 129.153.54.255
  ether 0:14:4f:6c:85:aa
nxge3: flags=201000803<UP,BROADCAST,MULTICAST,IPv4,CoS> mtu 1500
index 20
  inet 129.153.54.171 netmask ffffffff broadcast 129.153.54.255
  ether 0:14:4f:6c:85:ab
```

2. Unplumb each active port (each port named `nxge` plus an instance number, for example, `nxge2`, `nxge3`, ...). Example:

```
# ifconfig nxge2 unplumb
# ifconfig nxge3 unplumb
```

3. Run `ifconfig -a` again to verify that there are no active `nxge` interfaces.  
Example:

```
# ifconfig -a
lo0: flags=2001000849<UP,LOOPBACK,RUNNING,MULTICAST,IPv4,VIRTUAL>
mtu 8232 index 1
  inet 127.0.0.1 netmask ff000000
bge0: flags=201000843<UP,BROADCAST,RUNNING,MULTICAST,IPv4,CoS>
mtu 1500 index 2
  inet 129.153.54.82 netmask ffffffff broadcast 129.153.54.255
  ether 0:14:4f:2a:9f:6a
```

It is now safe to unload the `nxge` driver.

## Jumbo Frames Throughput of `nxge` Drops to 30 Mbps Due to Packet Dropping (CR 6554478)

This issue is resolved for servers running the Solaris 10 5/08 OS and later. If you are running Solaris 10 8/07, you can fix this issue with patch ID 127127-11 or later.

Receive-side performance of the `nxge` driver drops significantly if the following two conditions are true:

- Jumbo Frames are enabled because the following line is present and not commented out in the `nxge.conf` file:

```
accept_jumbo=1
```

The `nxge.conf` file is in the `/platform/sun4v/kernel/drv` directory on `sun4v` systems, and it is in the `/platform/sun4u/kernel/drv` directory on `sun4u` systems.

- Maximum Transmission Unit (MTU) is set to a value larger than 8172. When Jumbo Frames are enabled, the MTU size defaults to 9194.

---

**Note** – Refer to the *Sun Quad GbE UTP x8 PCIe ExpressModule User's Guide*, the *Sun Dual 10GbE XFP PCIe ExpressModule User's Guide*, the *Sun x8 Express Dual 10 Gigabit Ethernet Fiber XFP Low Profile Adapter User's Guide*, or the *Sun x8 Express Quad Gigabit Ethernet UTP Low Profile Adapter User's Guide* for details.

---

## ▼ To Set the MTU Size to 8172

If Jumbo Frames are enabled, use this procedure to set the MTU to a value of 8172. This procedure uses *port1* as an example.

1. **Edit or create an `/etc/hosts` file and add the following line in it:**

```
99.99.9.1 nxge-port1
```

Where *nxge-port1* is the name you give to the interface, and *99.99.9.1* is the IP address you want to assign to the interface.

2. **Edit or create a `/etc/hostname.nxge1` file and place the following two lines in it:**

```
nxge-port1  
nxge-port1 mtu 8172
```

3. **If you want the system to set the netmask to a special value automatically, add the following line in the `/etc/netmasks` file (using netmask *FFFFFF00* as an example):**

```
99.99.9.1 255.255.255.0
```

4. **Reboot the system.**

In this example, the `nxge1` interface is automatically plumbed with IP address `99.99.9.1`, MTU value `8172` and netmask `ffffff00`.

5. **Type `ifconfig -a` to confirm the configuration:**

```
# ifconfig -a  
nxge1: flags=1201000802<BROADCAST,MULTICAST,IPv4,CoS,FIXEDMTU>  
mtu 8172 index 3  
inet 99.99.9.1 netmask fffffff0 broadcast 99.255.255.255  
ether 0:14:4f:6c:88:5
```

If you want to set parameters permanently for other interfaces, create `/etc/hostname.nxge0`, `/etc/hostname.nxge2` and `/etc/hostname.nxge3` similarly, and add the name IP-address pairs to the same `/etc/hosts` file. Also add their netmasks to the same `/etc/netmasks` file.

## Setting Properties for nxge Devices Might Fail (CR 6561389)

This issue is resolved for servers running the Solaris 10 5/08 OS and later. If you are running Solaris 10 8/07, you can fix this issue with patch ID 127127-11 or later.

Setting a property for an nxge device node might not work correctly. The following is an example:

```
name="SUNW,niusl" parent="/niu@80" unit-address="0" accept_jumbo=1;
name="SUNW,niusl" parent="/niu@80" unit-address="1" accept_jumbo=1;
Entries from /etc/path_to_inst:
/niu@80" 0 niumx
/niu@80/network@0" 0 nxge
/niu@80/network@1 1 nxge
Entries from /etc/driver_aliases:
niumx "SUNW,niumx
nxge "SUNW,niusl
```

Workaround: Use the global declaration without the device path in the `nxge.conf` file. For example, add the following line to the `nxge.conf` file.

```
accept_jumbo = 1;
```

## Server Might Panic in nxge\_start When dupb Fails (CR 6567838)

This issue is resolved for servers running the Solaris 10 5/08 OS and later. If you are running Solaris 10 8/07, you can fix this issue with patch ID 127127-11 or later.

If Jumbo Frames are enabled, it is possible for the system to panic as a result of a NULL pointer reference. This scenario is only possible when frame sizes are larger than 4076. Jumbo Frames with MTU=9194 do not experience this problem.

Workaround: Disable Jumbo Frames or use a smaller MTU size as described in the following procedures.

### ▼ To Disable Jumbo Frames

Disabling Jumbo Frames or using Jumbo Frames with a smaller MTU impacts system performance. Only perform the following steps if the system panics due to Jumbo Frames.

1. **Edit the `/platform/sun4v/kernel/drv/nxge.conf` file, and ensure that any line with `accept_jumbo=1`; is commented out.**
2. **Ensure that there is no `set nxge:nxge_jumbo_enable=1` in the `/etc/system` file.**

## ▼ To Set the MTU to a Smaller Size

If you want to use Jumbo Frames, you can use this workaround instead of disabling Jumbo Frames. This procedure sets the MTU to a value equal to or smaller than 4076, using `port1` as an example.

---

**Note** – By following these steps, the MTU values are permanent. As an alternative, you can run the command `ifconfig nxgeX mtu 4076` (where `X` is the instance number), but the MTU value will change back to the default one after a reboot.

---

1. **Edit or create an `/etc/hosts` file and add the following line in it:**

```
99.99.9.1    nxge-port1
```

Where `nxge-port1` is the name you assign to the interface. `99.99.9.1` is the IP address you want to assign to the interface.

2. **Create an `/etc/hostname.nxge1` file and place the following two lines in it:**

```
nxge-port1
nxge-port1 mtu 4076
```

# Firmware, ILOM, POST, and SP Issues

TABLE A-3 lists the firmware, ILOM, POST, and SP issues that have been fixed.

TABLE A-3 Fixed Firmware, ILOM, POST, and SP Issues

CR	Description	Workaround
6541482	<p>POST always starts on the lowest available strand even when that strand is disabled.</p> <p>If processor strand 0 of the first available physical core has been marked disabled (as seen in the list of disabled devices in the output of the <code>showcomponent</code> command), a new master strand is selected by the initialization process, and the disabled strand is taken offline. But the system initialization and execution of power-on-self-test (POST) occurs using the disabled processor strand, because power on and reset execution always starts on strand 0 of the first available physical core.</p> <p>When this situation happens, the system might fail to run the diagnostics and the system might fail in an unpredictable manner. The system might not start the required firmware and software components as a result.</p>	<p><b>Note - Fixed in System Firmware 7.1.6.d or later.</b></p> <p>If strand 0 of the first physical core is known to be good, then it can be enabled by using the <code>enablecomponent</code> ALOM CMT compatibility command followed by power-on reset of the system (<code>poweroff</code> followed by <code>poweron</code> ALOM CMT compatibility commands).</p> <p>If strand 0 of the first physical core is known to be bad, there is no workaround. The motherboard must be replaced.</p> <p>You can also update the System Firmware to the latest version to avoid encountering this issue.</p>
6549028	<p>The <code>netsc_commit</code> command might cause the system to hang.</p> <p>Through a serial connection, the network might not be visible.</p>	<p><b>Note - Fixed in System Firmware 7.1.6.d or later.</b></p> <p>Reboot the system.</p> <p>If rebooting fails to reset the SP, AC power cycle the system to recover the SP. Be aware that you will lose active domains.</p> <p>You can also update the System Firmware to the latest version to avoid encountering this issue.</p>
6583392 (6571886)	<p>POST might encounter intermittent POST PIU0 link train errors during a power cycle test.</p>	<p><b>Note - Fixed in System Firmware 7.1.6.d or later.</b></p> <p>Power cycle the system as follows (example uses the ALOM CMT compatibility CLI):</p> <pre>sc&gt; poweroff -fy sc&gt; clearasrdb sc&gt; poweron -c</pre> <p>You can also update the System Firmware to the latest version to avoid encountering this issue.</p>



**TABLE A-3** Fixed Firmware, ILOM, POST, and SP Issues (*Continued*)

CR	Description	Workaround
6577528	<p>A terminal server <code>break</code> command does not work on the SP serial port.</p> <p>If you use Telnet to connect to the SP serial line with a terminal server (such as the Cisco ASM series) and try to send a break to the Solaris host, the <code>break</code> command does not work and is ignored by the SP. For a sample output, see <a href="#">“SP Serial Line Terminal Server <code>break</code> Command Does Not Work (CR 6577528)”</a> on page 100.</p>	<p><b>Note - Fixed in System Firmware 7.1.6.d or later.</b></p> <p>Use the <code>break</code> commands from the SP (either the ILOM or ALOM CMT compatibility commands) to send a break to the Solaris host.</p> <p>Refer to the <i>Integrated Lights Out Management (ILOM) Supplement for SPARC Enterprise T5120 and T5220 Servers</i> for details.</p> <p>You can also update the System Firmware to the latest version to avoid encountering this issue.</p>
6579390	<p>After disabling a DIMM, the OpenBoot PROM banner does not show a decrease in the amount of memory.</p>	<p><b>Note - Fixed in System Firmware 7.2.2.e or later.</b></p> <p>If you manually disable any CPU or memory resource with the ASR commands while the host is powered on, you must power cycle the host to complete the disabling of the resource.</p> <p>After the power cycle, the resource will be disabled, and the proper information will be displayed in the banner.</p>
6581309	<p>Console behavior is inconsistent when a graphics device and keyboard are specified for console use.</p> <p>This behavior occurs when the OpenBoot variables <code>input-device</code> and <code>output-device</code> are set to anything other than the default value of <code>virtual-console</code>.</p> <p>If the control domain is set this way, some console messages are sent to the graphics console and others are sent to the virtual console. This situation results in incomplete information on both consoles. In addition, when the system is halted, or a break is sent to the console, control is passed to the virtual console, which requires keyboard input over the virtual console. As a result, the graphics console appears to hang.</p>	<p><b>Note - Fixed in Solaris patch ID 137111-01 or later.</b></p> <p>If the graphics console appears hung, connect to the virtual console from the system processor to provide the required input. Press Return on the virtual console keyboard once to see the output on the virtual console. If this workaround does not work, contact your service engineer.</p> <p>To prevent the problem, perform one of the following workarounds:</p> <ul style="list-style-type: none"> <li>• Install patch ID 137111-01 (or higher).</li> <li>• Use only the virtual console. Ensure that the default value of <code>virtual-console</code> is set for both the <code>input-device</code> and <code>output-device</code> variables.</li> </ul>
6582340	<p>When you are connected to the virtual console and you enter the escape character sequence (<code>. #</code>) to enter the SP CLI, the following two error messages might display before reaching the CLI prompt:</p> <pre>read: Connection reset by peer Write to vbsc: Illegal seek</pre> <p>This situation occurs when there is a lot of output through the console, and implies that the console is in use when it is not.</p>	<p><b>Note - Fixed in System Firmware 7.2.2.e or later.</b></p> <p>If you are refused write access when you initiate a connection to the host with the <code>console</code> command, enter <code>console -f</code> (the force option) to get read and write access.</p>

**TABLE A-3** Fixed Firmware, ILOM, POST, and SP Issues (Continued)

CR	Description	Workaround
6582853	The <code>showfaults</code> ALOM CMT compatibility command reports the motherboard as faulty instead of the actual faulty DIMM or PCIe card.	<p><b>Note - Fixed in System Firmware 7.1.6.d or later.</b></p> <p>Use the fault management utilities that are described in the Predictive Self-Healing (PSH) Knowledge Articles located at: <a href="http://www.sun.com/msg/MSGID">http://www.sun.com/msg/MSGID</a> (MSGID is the PSH Message ID.)</p> <p>For more information see “<a href="#">The showfaults Command Shows the Motherboard as Faulty Instead of the DIMM (CR 6582853)</a>” on page 101.</p> <p>You can also update the System Firmware to the latest version to avoid encountering this issue.</p>
6585340	The <code>uadmin 2 0</code> and <code>reboot</code> commands read old bootmode settings.	<p><b>Note - Fixed in System Firmware 7.1.6.d or later.</b></p> <p>See “<a href="#">The uadmin 2 0 and reboot Commands Read Old Bootmode Settings (CR 6585340)</a>” on page 102.</p> <p>You can also update the System Firmware to the latest version to avoid encountering this issue.</p>
6587869	Using the <code>consolehistory -e</code> command with a value greater than 1000 might result in the SP becoming unusable.	<p><b>Note - Fixed in System Firmware 7.1.6.d or later.</b></p> <p>To see the entire <code>consolehistory</code> log, use the <code>-v</code> option.</p> <p>If you need to recover from problems related to running the <code>consolehistory</code> command with more than 1000 lines, reboot the SP.</p> <p>You can also update the System Firmware to the latest version to avoid encountering this issue.</p>
6587919	The first time that <code>show /SYS</code> is executed after a power on, (none) is displayed for the product name.	<p><b>Note - Fixed in System Firmware 7.1.6.d or later.</b></p> <p>Use the <code>show /SYS</code> command again and the product name is displayed.</p> <p>You can also update the System Firmware to the latest version to avoid encountering this issue.</p>
6588999	When you connect to the ILOM CLI with SSH and the SP is reset, you might see an error message similar to the following: Performing hard reset on /SP failed reset: Transport error - check errno for transport error	<p><b>Note - Fixed in System Firmware 7.1.6.d or later.</b></p> <p>This error can be ignored. The command actually succeeds and the SP is reset. When the SP resets, you lose the SSH connection to the SP.</p> <p>You can also update the System Firmware to the latest version to avoid encountering this issue.</p>

**TABLE A-3** Fixed Firmware, ILOM, POST, and SP Issues (Continued)

CR	Description	Workaround
6589043	<p>If there are fewer than 21 entries in the event log, the <code>showlogs</code> command displays none of the events.</p> <p>This situation is known to occur in the following scenarios:</p> <ul style="list-style-type: none"> <li>• After a fresh installation of the system (out-of-box), the service processor (SP) event log is very likely to have fewer than 21 entries.</li> <li>• After you clear the SP event log with the browser interface (BI), or ILOM CLI, the ALOM CMT compatibility CLI <code>showlogs</code> command displays no new events until at least 21 new events are logged.</li> </ul>	<p><b>Note - Fixed in System Firmware 7.1.6.d or later.</b></p> <p>Use the <code>showlogs -v</code> option to display the logs. After 21 or more events are logged in the log file, you can revert back to using <code>showlogs</code> with no options.</p> <p>You can also update the System Firmware to the latest version to avoid encountering this issue.</p>
6591367	<p>You cannot obtain the system DIMM FRU information with the <code>ipmitool</code> utility.</p>	<p><b>Note - Fixed in System Firmware 7.1.6.d or later.</b></p> <p>Obtain the DIMM FRU information using the SP ALOM CMT compatibility CLI (with the <code>showfru</code> command) or the SP ILOM CLI (with the <code>show fru-name</code> command). Refer to the <i>Integrated Lights Out Management (ILOM) Supplement for SPARC Enterprise T5120 and T5220 Servers</i> for details.</p> <p>You can also update the System Firmware to the latest version to avoid encountering this issue.</p>
6593547	<p>An erroneous watchdog reset error might occur. If this error occurs, the system will not complete the boot sequence. You might see the following error in either the I/O or the Control domain when attempting to boot and the <code>boot</code> sequence will be aborted:</p> <pre>"ERROR: Last Trap: Watchdog Reset".</pre>	<p><b>Note - Fixed in System Firmware 7.1.6.d or later.</b></p> <p>The error is erroneous and can be ignored. Type <b>boot</b> at the <code>ok</code> prompt to proceed.</p> <p>You can also update the System Firmware to the latest version to avoid encountering this issue.</p>
6593801	<p>When all platform identity checks fail, system power on should be disabled. If enough of the FRUs are corrupted, the system cannot determine its identity, which makes certain components nonoperational and could crash the server.</p>	<p><b>Note - Fixed in System Firmware 7.1.3.d or later.</b></p>
6594506	<p>Domain ETM and LDC Deadlock When Transmit Queue Full</p> <p>For examples, see <a href="#">“Domain ETM and LDC Deadlock When Transmit Queue Full (CR 6594506)” on page 103.</a></p>	<p><b>Note - Fixed in Solaris patch ID 125369-12 or later.</b></p> <p>See <a href="#">“Domain ETM and LDC Deadlock When Transmit Queue Full (CR 6594506)” on page 103.</a></p>

**TABLE A-3** Fixed Firmware, ILOM, POST, and SP Issues (Continued)

CR	Description	Workaround
6598381	In rare circumstances, the PCIe interface unit (PIU) might issue a spurious error interrupt. For examples, see <a href="#">“Spurious PIU Errors (CR 6598381)” on page 106</a> .	<b>Note - Fixed in System Firmware 7.1.6.d or later.</b> These events are harmless and can be ignored. You can also update the System Firmware to the latest version to avoid encountering this issue.
6611700 (6601900)	When the OpenBoot PROM is set to <code>input-device=keyboard</code> , you might see the following warning message when the system host is powered on or reset: No keyboard support found A U.S. keyboard will work properly. International keyboards (French, German, and so on) might behave as U.S. keyboards.	<b>Note - Fixed in System Firmware 7.1.6.d or later.</b> Do not use USB keyboards. Instead, use a virtual console by setting the <code>input-device</code> variable to <code>virtual-console</code> . You can also update the System Firmware to the latest version to avoid encountering this issue.
6602913	IPMI power off or power cycle operations might fail.	<b>Note - Fixed in System Firmware 7.1.6.d or later.</b> Repeat the IPMI power off, or power-cycle operation, or use one of the other available interfaces to perform this operation. You can also update the System Firmware to the latest version to avoid encountering this issue.
6604305	During system initialization, memory might not be detected, and the following error is reported: ERROR: MB/CMP0/BR3/CH0/D0 must be populated. Rarely, the probing of DIMMs fails due to ILOM simultaneously updating DIMM information. When the DIMM probing fails, the host either boots with a reduced memory configuration, or fails to boot. This situation is not likely to happen when the service processor (SP) is reset, because the DIMMs are probed before ILOM starts dynamic <code>fruid</code> updates. This issue is most likely to occur when the host is being repeatedly powered on and off without resetting the SP.	<b>Note - Fixed in System Firmware 7.1.6.d or later.</b> Power off the host, reset the SP, and power on the host. You can also update the System Firmware to the latest version to avoid encountering this issue.
6612687	Repeated attempts to show or set the serial port properties of the host port might cause the ILOM CLI to hang and become unresponsive.	<b>Note - Fixed in System Firmware 7.0.9 or later.</b> Do not configure the host serial port properties from the service processor. Instead, set the properties from the Solaris OS. If the ILOM CLI hangs, you must reset the system by power cycling the AC power.

**TABLE A-3** Fixed Firmware, ILOM, POST, and SP Issues (*Continued*)

CR	Description	Workaround
6615884 (6614576)	The help message is incorrect in the ILOM BI. The informational text displayed on the Configuration Serial Port tab in the ILOM BI refers to a DB-9 connector, but the message should refer to the RJ-45 connector.	<b>Note - Fixed in System Firmware 7.0.9 or later.</b> Be aware of this discrepancy.
6616693	When the information obtained by using IPMI, the information such as the "Product Part Number" of the server is not displayed correctly.	<b>Note - Fixed in System Firmware 7.0.9 or later.</b> Log in to ILOM and refer to the information such as /SYS.
6618773	A diagnostic routine that runs at startup (IBIST) might disconnect the memory controller unit (MCU), resulting in errors. For an example of the errors, see <a href="#">"Diagnostic Routine That Runs at Startup (IBIST) Might Accidentally Disconnect the MCU (CR 6618773)" on page 107.</a>	<b>Note - Fixed in System Firmware 7.1.0.g or later.</b> Install Patch 127580-04 or later, and update the System Firmware to version 7.0.9 or later.
6622444	In the mirroring configuration of the system volume disk using the PRIMECLUSTER GDS, when an error occurred while reading the boot block of boot disk, the boot path does not switch. At this time, the following message appears and the process returns to the ok prompt. Boot load failed. The file just loaded does not appear to be executable. {0} ok	<b>Note - Fixed in System Firmware 7.0.9 or later.</b> When the process returned to the ok prompt, reexecute the boot command to start the OS.
6623454	Despite the change of SSH setting from "Disable" to "Enable" by using the "SSH Server" tab of BUI, it is displayed as "Disable."	<b>Note - Fixed in System Firmware 7.2.2.e or later.</b> The SSH setting has been changed to "Enable." Use the Refresh function of BUI.
6624658	Unless the system is stopped from the service processor, the system will be automatically powered on at the next AC power-on even if the HOST_LAST_POWER_STATE in /SP/policy is set to "enabled". The same applies if the HOST_AUTO_POWER_ON property is set to enabled but the system has not been stopped from the service processor.	<b>Note - Fixed in System Firmware 7.1.3.d or later.</b> To stop the system, use the command on the service processor. Moreover, when setting the HOST_AUTO_POWER_ON property to "enabled", also set the HOST_POWER_ON_DELAY property to "enabled".
6624699	Despite the change of Role to Administrator/Operator by using "Active Directory" of BUI, Role is displayed as blank.	<b>Note - Fixed in System Firmware 7.2.2.e or later.</b> Log in to ILOM and check the defaultrole property of /SP/clients/activedirectory.

**TABLE A-3** Fixed Firmware, ILOM, POST, and SP Issues (Continued)

CR	Description	Workaround
6643177	<p>If an attempt is made to power on the system with <code>poweron</code> ALOM CMT compatibility commands, power-on may fail with the following message displayed:</p> <pre>sc&gt; poweron Host poweron failed. poweron error: Internal error  sc&gt; poweron Error reading keyswitch value</pre>	<p><b>Note - Fixed in System Firmware 7.1.0.g or later.</b> None.</p>
6676309 6667409	<p>When using NTP services under Solaris OS, time correction with NTP may fail, and a time delay may occur.</p>	<p><b>Note - Fixed in System Firmware 7.1.3.d or later.</b> Alternatively, if the firmware is not updated, add the appropriate one of the commands below to the settings in the <code>/etc/system</code> file and restart Solaris OS.</p> <p>If the NTP correction mode is set to <code>slew</code> mode</p> <ul style="list-style-type: none"> <li>• and the processor speed is 1.2 GHz: <code>set sys_tick_freq=1165379275</code></li> <li>• and the processor speed is 1.4 GHz: <code>set sys_tick_freq=1415103392</code></li> </ul>
6610861 6613564	<p>The prompt and character sequence for dropping to the u-boot state is inconsistent with previous platforms.</p> <p>When the service processor is booting, pressing a key during the 5-second interval while the prompt <code>Hit any key to stop autoboot</code> is displayed causes the service processor boot sequence to stop and a u-boot prompt is displayed.</p>	<p><b>Note - Fixed in System Firmware 7.1.6.d or later.</b> Type the <code>boot</code> command to resume the service processor boot sequence. You can also update the System Firmware to the latest version to avoid encountering this issue.</p>
6656116	<p>If the DIMM module fails, the MCU will be disconnected, and an error message might be output to the console.</p> <p>For an example of the message, see <a href="#">“MCU Might Be Disconnected in DIMM Module Failure (CR 6656116)” on page 108</a>.</p>	<p><b>Note - Fixed in System Firmware 7.2.2.e or later.</b> Identify and replace the faulty DIMM module.</p>

**TABLE A-3** Fixed Firmware, ILOM, POST, and SP Issues (Continued)

CR	Description	Workaround
6654695	<p>The following message is displayed when the <code>clear_fault_action</code> property of the <code>/SYS</code> object is set to true, but no processing is executed:</p> <p>Message example:            Set <code>clear_fault_action</code> to true</p> <p>The <code>/SYS</code> object <code>clear_fault_action</code> property has been corrected in System Firmware 7.1.3.d or later.</p>	<p><b>Note - Fixed in System Firmware 7.1.3.d or later.</b></p> <p>Clear the error by using the FRU name provided by the <code>show /SP/faultmgmt</code> command.</p>
6768806	<p>An attempt to read the properties of the power supply unit (PSU) may be unsuccessful and cause the ILOM session to terminate.</p> <pre>-&gt; show -level all -o table /SYS/PSO Target        Property        Value -----+-----+----- Connection to XXX.XXX.XXX.XXX closed. %</pre>	<p><b>Note - Fixed in System Firmware 7.2.2.e or later.</b></p> <p>None.</p> <p>It is, however, possible to check the PSU properties with the <code>showfru</code> command of the ALOM CMT compatibility shell.</p>
6784525	<p>In a sixteen-disk capable server, the "Ready-to-Remove LED" does not go on when hard disks mounted in slots #8 to #15 are hot replaced.</p>	<p><b>Note - Fixed in System Firmware 7.2.2.e or later.</b></p> <p>Instead of using the "Ready-to-Remove LED," use the execution result of the <code>cfgadm -l</code> command. If the status becomes unconfigured, hot replacement is enabled.</p> <p>- Confirmation example -</p> <pre># cfgadm -l c1::dsk/c1t1d0 Ap_Id      Type  Receptacle Occupant   Condition c1::dsk/c1t1d0  disk  connected unconfigured  unknown #</pre>
6772707	<p>When the <code>showenvironment</code> command of the ALOM CMT compatibility shell is executed in a sixteen-disk capable server, even though the hard disk is mounted in slot #8, "NOT PRESENT" is output.</p> <p>For examples, see "When the <code>showenvironment</code> Command is Executed in a Sixteen-Disk Capable Server, Even Though the Hard Disk is Mounted in Slot #8, "NOT PRESENT" is Output. (CR 6772707)" on page 109.</p>	<p><b>Note - Fixed in System Firmware 7.2.2.e or later.</b></p> <p>The status can be confirmed from the ok prompt by using the <code>probe-scsi-all</code> command.</p> <p>For examples, see "When the <code>showenvironment</code> Command is Executed in a Sixteen-Disk Capable Server, Even Though the Hard Disk is Mounted in Slot #8, "NOT PRESENT" is Output. (CR 6772707)" on page 109.</p>

**TABLE A-3** Fixed Firmware, ILOM, POST, and SP Issues (Continued)

CR	Description	Workaround
6692478	Failures may occur in ILOM functions such as user account management if a prohibited character like "#", "+", or ":" is used for the first character of an ILOM user account.	<p><b>Note - Fixed in System Firmware 7.2.2.e or later.</b></p> <p>None.</p> <p>When the user account can be deleted, the ILOM can be recovered by deleting the user account. When the user can not be deleted, reset the ILOM configuration to factory defaults to recover the ILOM.</p> <p>For the details about procedures and valid characters for ILOM user accounts, see the "Integrated Lights Out Manager 2.0 User's Guide."</p>
6781815	<p>After the ILOM reset or the power cable removal and insertion, when the server powered on, Solaris OS startup at the ok prompt of OBP (OpenBoot PROM) using the boot command may fail.</p> <p>Error output example:</p> <pre data-bbox="212 736 658 852">{0} ok boot ERROR: All device paths in boot- device have failed. (*) {0} ok</pre> <p>It cannot refer to the device paths that configured in the OBP environmental variable boot-device and fails to start Solaris OS.</p>	<p><b>Note - Fixed in System Firmware 7.2.2.e or later.</b></p> <p>After the ILOM reset or the power cable removal and insertion, when you power on the server, check the OBP environmental variable. Especially, in case the OBP environmental variable use-nvramrc? has been set to true, it is necessary in advance of starting the OS to see the ok prompt and check that use-nvramrc? has been set to true and then execute the boot command.</p> <p>Confirmation example:</p> <pre data-bbox="729 857 1115 939">{0} ok printenv use-nvramrc? use-nvramrc? = true {0} ok</pre>
6782508	The /SP/powermgmt/policy property has been disabled.	<p><b>Note - Fixed in System Firmware 7.2.2.e or later.</b></p> <p>To /SP/powermgmt/policy, the following properties have become available.</p> <ul style="list-style-type: none"> <li>- Performance</li> </ul> <p>The system is allowed to use all the power that is available.</p> <ul style="list-style-type: none"> <li>- Elastic</li> </ul> <p>The system power usage is adapted to the current utilization level. For example, power up or down just enough system components to keep relative utilization at 70% at all times, even if workload fluctuates.</p> <p>This property is enabled only in the logical domain (LDom) environment.</p> <p>In case you are not in the logical domain (LDom) environment, or in case that the logical domain (LDom) configuration is the factory-default, the property setting is available but cannot utilize its power consumption control function.</p>



**TABLE A-3** Fixed Firmware, ILOM, POST, and SP Issues (Continued)

CR	Description	Workaround
6802433	For DC input power models, the INPUT limit value included in the output from the <code>showpower -v</code> command may differ between <code>/SYS/PS0</code> and <code>/SYS/PS1</code> . The <code>/SYS/PS1</code> value is correct. For examples, see <a href="#">“For DC Input Power Models, the Output From the showpower -v Command May Differ Between /SYS/PS0 And /SYS/PS1 (CR 6802433)”</a> on page 111.	<b>Note - Fixed in System Firmware 7.2.2.e or later.</b> None. Ignore this issue because it is only a display error.
6801248	For DC input power models, the following event log might be repeatedly collected when the power to the system is turned on: [Sample output from the <code>showlogs</code> command] Chassis minor:"Error getting status DC volt for PS0" Chassis minor:"Error getting status DC volt for PS1" Chassis minor:"Error getting status DC volt for PS0" Chassis minor:"Error getting status DC volt for PS0"	<b>Note - Fixed in System Firmware 7.2.2.e or later.</b> None. Ignore this event log.
6819987	For DC input power models, the following event log might be repeatedly collected: [Sample output from the <code>showlogs</code> command] IPMI  minor : "ID = 20a : 03/11/2009 : 02:31:48 : Current : /PS0/CUR_FAULT : State Asserted" IPMI  minor : "ID = 20b : 03/11/2009 : 02:31:51 : Temperature : /PS0/TEMP_FAULT : State Asserted" IPMI  minor : "ID = 20c : 03/11/2009 : 02:31:54 : Current : /PS0/CUR_FAULT : State Deasserted" IPMI  minor : "ID = 20d : 03/11/2009 : 02:31:57 : Temperature : /PS0/TEMP_FAULT : State Deasserted"	<b>Note - Fixed in System Firmware 7.2.2.e or later.</b> None. If the Service Required, Overtemp, and Power Supply Service Required LEDs on the server are off, ignore the event log items. If one of these LEDs is on, indicating that a power supply problem or temperature-related problem has occurred, correct the problem.
6821325	In the output from the <code>prtdiag</code> command, warnings may be displayed for input voltage sensors ( <code>V_IN_MAIN</code> ) on power supply units. For examples, see <a href="#">“In the Output From the prtdiag Command, Warnings May Be Displayed (CR 6821325)”</a> on page 112.	<b>Note - Fixed in System Firmware 7.2.7.b or later.</b> None. Ignore this issue because it is only a display error.

**TABLE A-3** Fixed Firmware, ILOM, POST, and SP Issues (Continued)

CR	Description	Workaround
6586305	Using the SP <code>setdate</code> command (ALOM compatibility shell) after having configured non-default logical domains can cause the date on non-default domains to change.	<p><b>Note - Fixed in System Firmware 7.2.2.e or later.</b></p> <p>Use the <code>setdate</code> command to configure the date on the SP before configuring and saving logical domain configurations.</p> <p>If you use <code>setdate</code> after non-default logical domain configurations have been saved, each non-default domain must be booted to Solaris and the date corrected. (See <code>date(1)</code> or <code>ntpdate(1M)</code>.)</p>
6733632	When the ILOM <code>show -level all /SYS</code> command is executed, information under <code>/SYS/MB/SP</code> is not displayed.  When <code>show -level all /SYS/MB</code> is executed, information under <code>/SYS/MB/SP</code> is not displayed either.	<p><b>Note - Fixed in System Firmware 7.2.2.e or later.</b></p> <p>Use the <code>show /SYS/MB/SP</code> command.</p>
6757022	Resetting the service processor while the host is powered on can cause the host to crash.	<p><b>Note - Fixed in System Firmware 7.2.2.e or later.</b></p> <p>Do not reset the service processor while the system is powered on. If you encounter this issue, power cycle the server.</p>
6654395	If the LDoms Manager is active on a host machine, do not reset the service processor while the host machine is powered on. If the service processor is reset while the system power is active, the machine must be power-cycled before the LDoms Manager can start properly.	<p><b>Note - Fixed in System Firmware 7.1.0.g or later.</b></p>
6613209	When moving the SCC chip from one system to another, if the value of <code>/HOST/diag trigger</code> (or <code>diag_trigger</code> ) has two values (such as <code>power-on-reset error-reset</code> ), the values are restored incorrectly from the SCC chip to the new system. The values will be restored without a space separating them (for example, <code>power-on-reseterror-reset</code> ). This situation will result in POST not being run when the host is reset.	<p><b>Note - Fixed in System Firmware 7.1.3.d or later.</b></p> <p>When moving an SCC chip from one system to another, verify that the values of <code>/HOST/diag trigger</code> are correct. If the values are not correct, set them to the desired value.</p>
6639312	The <code>/SYS/MB/CMPx</code> components have a <code>fault_state</code> property and a <code>clear_fault_action</code> property. These components should not have these properties since they are not FRUs, and cannot be faulted or have their fault state cleared.  However, if a <code>/SYS/MB/CMPx</code> component fails, that <code>fault_state</code> property of the <code>/SYS/MB</code> target will be updated correctly.	<p><b>Note - Fixed in System Firmware 7.1.0.g or later.</b></p> <p>Ignore the <code>fault_state</code> and <code>clear_fault_action</code> properties of the <code>/SYS/MB/CMPx</code> targets. Use the <code>fault_state</code> and <code>clear_fault_action</code> property of <code>/SYS/MB</code>.</p>

**TABLE A-3** Fixed Firmware, ILOM, POST, and SP Issues (Continued)

CR	Description	Workaround
6694475	<p>It is impossible to use options of the <code>showfru</code> command on the ALOM CMT compatibility shell. All information will be displayed regardless of the option specified.</p> <pre>showfru [-g lines] [-s -d] [FRU]</pre> <ul style="list-style-type: none"><li>-g: Only the specified line</li><li>-s: Only static information</li><li>-d: Only dynamic information</li></ul>	<p><b>Note - Fixed in System Firmware 7.1.6.d or later.</b></p> <p>None</p>
6694693	<p>ILOM allows only two privileges: Administrator and Operator. Therefore, the following text about the ALOM CMT <code>userperm</code> command in the manual is inappropriate.</p> <p>If one of [c], [u], [a], and [r] is set, Administrator authority will be in effect. If nothing is specified, Operator authority will be in effect.</p> <p><i>&lt;Integrated Lights Out Manager 2.0 Supplement&gt;</i></p> <pre>userperm [username] [c][u][a][r]</pre>	<p><b>Note - Fixed in System Firmware 7.2.2.e or later.</b></p> <p>None</p>
6738989	<p>The SNMP tab of the ILOM Web interface does not have an item for setting <code>engineid</code>.</p>	<p><b>Note - Fixed in System Firmware 7.2.2.e or later.</b></p> <p>Use the “<code>set /SP/services/snmp engineid=(value)</code>” command from the CLI to set <code>engineid</code>.</p>
6729474	<p>-The <code>powercycle</code> command of the ILOM browser interface does not secure sufficient time for normal power-off of the system and may fail to complete powercycle.</p>	<p><b>Note - Fixed in System Firmware 7.2.2.e or later.</b></p> <p>None.</p>

**TABLE A-3** Fixed Firmware, ILOM, POST, and SP Issues (Continued)

CR	Description	Workaround
6731227	<p>Two circumstances can cause a logical domain to hang when reassigning I/O branches from the primary domain (control domain) to a guest domain (I/O domain):</p> <p><b>Case 1</b> - If you remove an I/O branch from the logical domain configuration of the primary domain and then add the same I/O branch back to the primary domain, upon reboot the system might come back up without any I/O, the system might hang in OpenBoot, or the entire I/O branch and the associated I/O devices might be absent from the primary domain. For example, the following actions performed in the sequence shown might lead to the primary domain hanging in OpenBoot:</p> <ol style="list-style-type: none"> <li>1. <code>ldm rm-io pci@500 primary</code> (Remove pci@500 from the configuration)</li> <li>2. <code>ldm rm-io pci@600 primary</code> (Remove pci@600 from the configuration)</li> <li>3. <code>ldm add-io pci@500 primary</code> (Add pci@500 back to the configuration)</li> <li>4. <code>ldm add-config config_name</code> (Save new configuration to SP)</li> <li>5. clean shutdown and power cycle</li> </ol> <p><b>Case2</b> - If the you assign I/O branches to guest domains in any order except in numerical order, one or more of the guest domains will be unable to start. For example, the following actions performed in the sequence shown might lead to one or more guest domains hanging when they are started:</p> <ol style="list-style-type: none"> <li>1. <code>ldm add-io pci@600 guestA</code></li> <li>2. <code>ldm add-io pci@500 guestB</code></li> <li>3. <code>ldm add-io pci@700 guestC</code></li> </ol>	<p><b>Note - Fixed in System Firmware 7.2.2.e or later.</b> Both situations can be avoided by following these guidelines:</p> <p><b>Case 1</b> - Do not remove an I/O branch from the primary domain and then immediately add it back to the primary domain.</p> <p><b>Case 2</b> - Be certain to add the I/O branches to the guest domains in numerical order.</p> <p>Example #1: The primary domain is using pci@400 (onboard disks/USB/DVD and slots PCIE0 and PCIE1), and you want to assign pci@500, pci@600, and pci@700 to three guests. Do the following:</p> <ol style="list-style-type: none"> <li>1. <code>ldm add-io pci@500 guestB</code></li> <li>2. <code>ldm add-io pci@600 guestA</code></li> <li>3. <code>ldm add-io pci@700 guestC</code></li> </ol> <p>Example #2: The primary domain is using pci@500 (onboard 1Gb/sec and 10Gb/sec network, slots PCIE4, PCIE5, XAUI0, XAUI1), and you want to assign pci@400, pci@600, and pci@700 to three guests. Do the following:</p> <ol style="list-style-type: none"> <li>1. <code>ldm add-io pci@400 guestB</code></li> <li>2. <code>ldm add-io pci@600 guestA</code></li> <li>3. <code>ldm add-io pci@700 guestC</code></li> </ol> <p>If you encounter this hang, you can recover by booting the system with either a prior working configuration or with the factory default configuration.</p> <p>The system can be booted to an earlier working configuration or in the factory default configuration by executing following sequence of commands in the ALOM CLI on the service processor (SP):</p> <ol style="list-style-type: none"> <li>1. <code>sc&gt; bootmode config="name_of_config"</code></li> <li>2. <code>sc&gt; poweron</code></li> <li>3. <code>sc&gt; poweroff</code></li> </ol> <p>The <i>name_of_config</i> is the working configuration saved on the service processor. If no such configurations exists on the service processor, use "factory-default" as the name of the configuration.</p> <p><b>Note</b> - If the "factory-default" configuration is used in the above procedure then you must reconfigure all of the guest domains and the primary domain.</p>

**TABLE A-3** Fixed Firmware, ILOM, POST, and SP Issues (*Continued*)

CR	Description	Workaround
6730610	<p>In certain circumstances you might encounter these error messages when powering on T5120/T5220 servers:</p> <pre>Chassis   major: Jul 27 16:40:17 ERROR: dt_allocprop: prop == NULL: Not enough memory to expand MD for new property fwd  Chassis   major: Jul 27 16:40:17 ERROR: dt_allocnode: Not enough memory to expand MD for new node mblock  Chassis   critical: Jul 27 16:41:55 FATAL: The Service Processor software has taken a FATAL configuration error,  Chassis   critical: the HOST Process cannot be started.  Chassis   critical: Please examine the logs to determine the reason for failure and then  Chassis   critical: reset the Service Processor</pre> <p>This error is encountered when there is a large difference between the amount of memory on the different CMP and memory modules. For example, this could happen if the memory on CMP0+MEM0 added up to 128 Gbytes, but the memory on CMP1+MEM1 were only 16 Gbytes. This situation might happen in two different situations; each situation has its own recovery procedure.</p>	<p><b>Note - Fixed in System Firmware 7.2.2.e or later.</b></p> <p><b>Case 1</b> - POST has determined that multiple FB-DIMMS have failed on T5120/T5220 servers with 64 8-Gbyte FB-DIMMS</p> <p><b>Recovery 1</b> - If POST takes a FB-DIMM offline, you must replace it immediately. If replacing the failed FB-DIMM is not immediately possible or desired, you must disable the corresponding FB-DIMMs on the other CMP/memory modules' corresponding memory branches to guarantee a contiguous memory configuration.</p> <p>Type one of the following:</p> <pre>-&gt; set /SYS/component component_state=disabled sc&gt; disablecomponent asr-key</pre> <p>Type one of the following commands to display a list of enabled and disabled devices:</p> <pre>-&gt; show components sc&gt; showcomponent</pre> <p>For each FB-DIMM device that is disabled, disable the corresponding FB-DIMM associated with the other CMP/memory module units. For example, if the following device was disabled:</p> <pre>/SYS/MB/MEM0/CMP0/BR0/CH0/D1</pre> <p>then disable the following additional devices:</p> <pre>/SYS/MB/MEM1/CMP1/BR0/CH0/D1 /SYS/MB/MEM2/CMP2/BR0/CH0/D1 /SYS/MB/MEM3/CMP3/BR0/CH0/D1</pre> <p><b>Case 2</b> - You have added new FB-DIMM modules to T5120/T5220 servers and have configured one of the CMP/memory module pairs with significantly more memory than the other modules</p> <p><b>Recovery 2</b> - Reallocate the FB-DIMMs across the CMP/memory modules to keep the total number and types of FB-DIMMs the same on each CMP/memory module pair.</p>
6731027	<p>Under certain conditions, the system might not power off when the Solaris OS is halted. The system might appear unresponsive in this case with no messages in at the system console or on the SC console.</p>	<p><b>Note - Fixed in System Firmware 7.2.2.e or later.</b></p> <p>Power off the system using one of the following methods:</p> <ul style="list-style-type: none"> <li>• The ILOM <code>stop/SYS</code> command</li> <li>• The ALOM <code>poweroff</code> command</li> </ul>

**TABLE A-3** Fixed Firmware, ILOM, POST, and SP Issues (Continued)

CR	Description	Workaround
6652046	POST error messages for some types of XAUI test failures can be misleading. The POST error messages can identify the correct port while reporting the wrong slot number.	<b>Note - Fixed in System Firmware 7.1.0.g or later.</b> XAUI port and slot numbers should match for the SPARC Enterprise T5120 and T5220 servers. Use the port number.
6656072	POST failure messages can specify the wrong CPU.	<b>Note - Fixed in System Firmware 7.1.0.g or later.</b>
6743343	Test Alert generation (alert test transmission) may not be possible, depending on the "Alert Type" and "Event" under the alert rule settings.	<b>Note - Fixed in System Firmware 7.2.2.e or later.</b> None.
6847308	In the backup of the ILOM settings, when the value of the system identifier property ( <code>/SP system_identifier</code> ) is its default value ( <code>none</code> ), the value of the system description property ( <code>/SP system_description</code> ) will be stored in the backup file. Example of erroneously stored data: <entry> <property>/SP/system_identifier </property> <value>SPARC-Enterprise-T5120, ILOM v3.0.3.20.e, r46064</value> </entry>	<b>Note - Fixed in System Firmware 7.2.7.b or later.</b> None. Delete the entry of " <code>/SP system_identifier</code> " in the backup file.
6835860	For SPARC Enterprise T5220 Server, during the power-on self-test (POST), the "ERROR:POST timed out" message may appear and the diagnostic process may terminate halfway. For the example, see <a href="#">"During the Power-On Self-Test, the Diagnostic Process May Terminate Halfway (CR 6835860)"</a> on page 113.	<b>Note - Fixed in System Firmware 7.2.7.b or later.</b> None. Power on the host again and perform the power-on self-test (POST).
6823516	In the DNS client settings, the number of retries ( <code>retries</code> property) cannot be set to "5."	<b>Note - Fixed in System Firmware 7.2.7.b or later.</b> None. Set the integer between "0" and "4" to the number of retries.
6823725	Once you set the <code>searchpath</code> property of the DNS client function, you cannot change it back to the default value ( <code>none</code> ).	<b>Note - Fixed in System Firmware 7.2.7.b or later.</b> None.

**TABLE A-3** Fixed Firmware, ILOM, POST, and SP Issues (Continued)

CR	Description	Workaround
6853843	<p>On the DC input power model of SPARC Enterprise T5120 Server, when you execute the <code>prtdiag</code> command of Solaris OS, the "Environmental Status" and some part of the "FRU Status" information is not displayed. For the incomplete data output example, see <a href="#">"On the DC Input Power Model, the "Environmental Status" and Some Part of the "FRU Status" Information Is Not Displayed (CR 6853843)"</a> on page 114.</p>	<p><b>Note - Fixed in System Firmware 7.2.7.b or later.</b> None. From ILOM, check the component information and the status of fan, temperature, power sensor and so on.</p>
6856163	<p>If the service processor is initialized with the LAN cable disconnected from the ILOM network port, the ILOM firmware serial console window displays an error message indicating a failure to start an ILOM internal process. As a result, ILOM fails to start. For details, see <a href="#">"When the Service Processor Is Initialized, ILOM May Fails to Start With an Error Message Displayed (CR 6856163)"</a> on page 115.</p>	<p><b>Note - Fixed in System Firmware 7.2.7.b or later.</b> Initialize the service processor with the LAN cable connected to the ILOM network port. As long as the network port is linked up, the service processor can be initialized, even without ILOM network settings. For procedures to restore normal system operation, see <a href="#">"When the Service Processor Is Initialized, ILOM May Fails to Start With an Error Message Displayed (CR 6856163)"</a> on page 115.</p>
6857271	<p>During SCC module replacement, part of the data kept on the motherboard is inadvertently overwritten with new SCC module data. This results in a connection failure to the ILOM network. For details, see <a href="#">"After the SCC Module Replacement, a Connection to the ILOM Network May Fail (CR 6857271)"</a> on page 117</p>	<p><b>Note - Fixed in System Firmware 7.2.7.b or later.</b> If only the SCC module fails, replace the SCC module together with the motherboard. After replacing these components, restore the backed up contents.</p>
6854379	<p>After the replacement of motherboard, the values for properties stored in the <code>/HOST/diag</code> directory may not be carried over, even though system configuration card (SCC module) is moved to the new motherboard.</p>	<p><b>Note - Fixed in System Firmware 7.2.7.b or later.</b> None. Before replacing the motherboard, back up the ILOM settings. After the replacement, restore the backed up settings.</p>
6816507	<p>After mounted the 10GbE XAUI card, when you insert the power cable, the component information of the 10GbE XAUI card does not appear on ILOM. ILOM recognized the 10GbE XAUI card.</p>	<p><b>Note - Fixed in System Firmware 7.2.7.b or later.</b> None. To confirm the component information of the 10GbE XAUI card from ILOM, check it after you power on the host.</p>

# SP Serial Line Terminal Server break Command Does Not Work (CR 6577528)

This issue is resolved by updating the system firmware to 7.1.6.d or later.

If you use Telnet to connect to the SP serial line with a terminal server (such as the Cisco ASM series) and try to send a break to the Solaris host, the `break` command does not work and is ignored by the SP. Use the `break` command from the SP CLI to send a break to the Solaris host.

The following is sample output of sending a break to the Solaris host from the ALOM CMT compatibility CLI:

1. Log into the host with the `console` command.

```
sc> console
```

2. Enter `#.` to return to the host prompt.

```
sc> #.  
Solaris-host-prompt>
```

3. Enter `#.` to escape to the SP ALOM CMT compatibility CLI. The escape sequence is not echoed.

```
Solaris-host-prompt> #.  
sc>
```

4. Enter the `break` command.

```
sc> break -c -y
```

5. Enter `#.` to return to the SP ALOM CMT compatibility CLI.

```
sc> #.  
c)ontinue, s)ync, r)eboot, h)alt>
```

The following is sample output of sending a break to the Solaris host from the SP ILOM CLI:

1. Log into the host with the ILOM `console` command.

```
-> start /SP/console  
Are you sure you want to start /SP/console (y/n)? y  
Serial console started. To stop, type #.  
Solaris-host-prompt>
```



2. Enter #. to escape to the SP ILOM CLI. The escape sequence is not echoed.

```
Solaris-host-prompt> #.  
->
```

3. Enter the break command as follows.

```
-> set /HOST send_break_action=break  
->
```

Log back into the Solaris host with the console command.

```
-> start /SP/console  
Are you sure you want to start /SP/console (y/n)? y  
Serial console started. To stop, type #.  
c)ontinue, s)ync, r)eboot, h)alt?
```

Refer to the *Integrated Lights Out Manager 2.0 User's Guide* and the *Integrated Lights Out Management (ILOM) Supplement for SPARC Enterprise T5120 and T5220 Servers* for details on how to use the break command from the SP CLIs.

## The showfaults Command Shows the Motherboard as Faulty Instead of the DIMM (CR 6582853)

This issue is resolved by updating the system firmware to 7.1.6.d or later.

In a system with DIMMs or PCIe adapters that have been faulted by PSH (Predictive Self-Healing) diagnosis on the host, the ALOM showfaults command displays the faulty FRU as the motherboard (/SYS/MB) instead of the DIMM or PCIe adapter. This problem will occur for the following PSH Message-IDs (MSGID):

- SUN4V-8000-E2
- SUN4V-8000-D
- SUN4-8000-4P
- SUN4-8000-A2
- SUN4-8000-75
- SUN4-8000-9J
- SUN4-8000-D4
- PCIEX-8000-0A
- PCIEX-8000-DJ

## ■ PCIEX-8000-HS

The following example from the ALOM CMT compatibility CLI illustrates the problem. In this example, the faulty FRU displayed is the motherboard (/SYS/MB) when the actual faulty component is a memory DIMM.

```
sc> showfaults -v
Last POST Run: Jul. 13 18:32:11 2007

Post Status: Passed all devices
ID Time          FRU          Class          Fault
0 Jul 13 19:31:34 /SYS/MB      Host detected fault, MSGID:
SUN4V-8000-DX   UUID: 7b471945-ceed-eea0-c3ad-85ca140be5b2
```

In addition, there is a problem with the output displayed by the show /SYS/faultmgmt command (ILOM CLI). The `fault_state` property of components, and the faulted components listed under the Fault Management tab in the ILOM BI are incorrect for the PSH Message-IDs listed above. Also, the FB-DIMM fault indicator will not operate, and the FRUID for the motherboard will have a fault recorded.

Workaround: Use the Fault Management utilities on the host to find the location of the faulty DIMM(s) or PCIe adapters. Instructions for using these utilities for these faults can be found in the Predictive Self-Healing Knowledge Articles located at: <http://www.sun.com/msg/MSGID>

where *MSGID* is one of the PSH Message IDs listed in the bulleted list in this section and displayed by the ALOM `showfaults` command.

For faulty DIMMs, refer to the DIMM label on the air duct or system cover to verify the DIMM location.

Once the faulty DIMM is replaced and the PSH fault has been cleared, the entry in `showfaults` will be deleted, and the fault recorded in the motherboard FRUID will be cleared.

## The `uadmin 2 0` and `reboot` Commands Read Old Bootmode Settings (CR 6585340)

This issue is resolved by updating the system firmware to 7.1.6.d or later.

You can change LDOMs variables in the control domain in one of three ways, with the OpenBoot `setenv` command in the control domain, with the Solaris `eeeprom` command in the control domain, or using ILOM `bootmode bootscript` option.

Changes made with the `setenv` and `eeprom` commands take effect immediately. Changes made with the `bootmode` command are supposed to take effect on the next reset, no matter what kind of reset it is.

Changes made in any of these three ways are supposed to stay in effect until the next change. That is, it doesn't matter how the value of an LDOMs variable is changed. Once changed, the value is supposed to stay in effect until it is changed again.

However, due to this issue, changes made with the `bootmode` command will become effective only after a power-on reset and will, on every reset (other than a power-on reset) that follows, override any intervening change made with the `setenv` or `eeprom` commands. That is, the changes made by the `bootmode` command require a power-on reset to be effective. Changes made with the `setenv` or `eeprom` commands will only persist until the next reset, at which point the variable will revert to the value set by the last `bootmode` command. This persistence of the `bootmode` setting will persist until the machine is power-cycled. Upon power cycling, the prior `bootmode` setting will not take effect. Any subsequent change made by the `setenv` or `eeprom` command will now persist over resets, at least until the next `bootmode` command followed by a power cycle.

Workaround: Restart the control domain with a power-on reset right after the `bootmode` command is executed, and restart again after the control domain boots to either OpenBoot or Solaris. The first power-on reset will make the `bootmode` command effective and the second power-on reset will workaround the persistence issue.

The control domain can be reset using power-on reset with the ALOM CMT compatibility CLI `powercycle` command. If the control domain is booted to the Solaris OS, remember to properly shut down the OS before executing the `powercycle` command.

## Domain ETM and LDC Deadlock When Transmit Queue Full (CR 6594506)

This issue is resolved with Solaris patch ID 125369-12 or later.

After certain hardware error events, it is possible that PSH events are no longer transported between the Service Processor (SP) and the domain. The scenarios subject to this CR:

- In a non-LDOMs environment, an unrecoverable error in the Solaris domain
- In an LDOMs environment, an unrecoverable error in the control domain
- In either an LDOMs or non-LDOMs environment, a fatal error in the system (a fatal error resets the system at the HW level)

---

**Note** – In an LDom environment, unrecoverable errors in a non-control LDom guest domain are *not* subject to this CR.

---

For example, an unrecoverable error in the control domain causes Solaris to panic. Messages similar to the following are reported to the control domain console:

```
SUNW-MSG-ID: SUNOS-8000-0G, TYPE: Error, VER: 1, SEVERITY: Major
EVENT-TIME: 0x46c61864.0x318184c6 (0x1dfeda2137e)
PLATFORM: SUNW,SPARC-Enterprise-T5220, CSN: -, HOSTNAME: wgs48-100
SOURCE: SunOS, REV: 5.10 Generic_Patch
DESC: Errors have been detected that require a reboot to ensure system
integrity. See http://www.sun.com/msg/SUNOS-8000-0G for more information.
AUTO-RESPONSE: Solaris will attempt to save and diagnose the error telemetry
IMPACT: The system will sync files, save a crash dump if needed, and reboot
REC-ACTION: Save the error summary below in case telemetry cannot be saved
```

Or, an unrecoverable error causes the Hypervisor to abort and messages similar to the following are reported to the SP console when logged into the ALOM CMT compatibility CLI console:

```
Aug 17 22:09:09 ERROR: HV Abort: <Unknown?> (228d74) - PowerDown
```

After the control domain recovers, there is a diagnosis performed. Messages to the console indicate the cause of the unrecoverable error. For example:

```
SUNW-MSG-ID: SUN4V-8000-UQ, TYPE: Fault, VER: 1, SEVERITY: Critical
EVENT-TIME: Fri Aug 17 18:00:57 EDT 2007
PLATFORM: SUNW,SPARC-Enterprise-T5220, CSN: -, HOSTNAME: wgs48-100
SOURCE: cpumem-diagnosis, REV: 1.6
EVENT-ID: a8b0eb18-6449-c0a7-cc0f-e230a1d27243
DESC: The number of level 2 cache uncorrectable data errors has exceeded
acceptable levels. Refer to http://sun.com/msg/SUN4V-8000-UQ for more
information.
AUTO-RESPONSE: No automated response.
IMPACT: System performance is likely to be affected.
REC-ACTION: Schedule a repair procedure to replace the affected resource,
the identity of which can be determined using fmdump -v -u <EVENT_ID>.
```

At this point, CR 6594506 might have been encountered. This will prevent future PSH events (for example, new HW errors, correctable or uncorrectable) from being transported into the domain and properly diagnosed.

Workaround: After the domain recovers and the diagnosis message is printed to the Solaris console, reset the service processor:

```
sc> resetsc -y [ALOM CMT compatibility CLI]  
OR  
-> reset /SP [ILOM CLI]
```

Once the SP is restarted and you are able to login as the admin (which means all daemons are ready), execute the following in the Solaris control domain to unload and load the etm.:

```
# fmadm unload etm  
# fmadm load /usr/platform/sun4v/lib/fm/fmd/plugins/etm.so
```

## Spurious PIU Errors (CR 6598381)

This issue is resolved by updating the system firmware to 7.1.6.d or later.

In rare circumstances, the PIU (PCIe interface unit) might issue a spurious error interrupt.

The following is an example of the event reported after diagnostics:

```
SUNW-MSG-ID: FMD-8000-0W, TYPE: Defect, VER: 1, SEVERITY: Minor
EVENT-TIME: Mon Aug 27 10:07:33 EDT 2007
PLATFORM: SUNW,SPARC-Enterprise-T5220, CSN: -, HOSTNAME: xxxxxxxx
SOURCE: fmd-self-diagnosis, REV: 1.0
EVENT-ID: dd9a4415-9be4-cb55-d061-8804b8009d3c
```

The following is an example of the event reported by the `fmdump` command:

```
# fmdump -eV -u dd9a4415-9be4-cb55-d061-8804b8009d3c
TIME                               CLASS
Aug 27 2007 10:06:15.496599680 ereport.fm.ferg.invalid
nvlist version: 0
class = ereport.fm.ferg.invalid
ena = 0xd4e233fe480002
info = DMU Core and Block Error Status(0): No bits set
  raw-data = 0x2 0x1a62441a01d844 0x3000000000000005 0x4b63c07df9ff
0x3e002421030607 0x
3e 0x0 0x0 0x0 0x0 0x0 0x0 0x0 0x0 0x0 0x0 0x0 0x0 0x0 0x0
__ttl = 0x0
__tod = 0x46d2da57 0x1d998280
```

These events are harmless and can be ignored.

## Diagnostic Routine That Runs at Startup (IBIST) Might Accidentally Disconnect the MCU (CR 6618773)

This issue is resolved by updating the system firmware to 7.1.0.g or later.

In some cases, the MCU is disconnected from corresponding DIMM modules and CPU cores, and the following messages are reported to the console.

For example:

```
Chassis | major: Host has been powered on
Chassis | major: Dec 19 08:45:11 ERROR: MB/CMP0/MCU2 Failed IBIST,
disabled
Fault | critical: SP detected fault at time Wed Dec 19 08:45:12
2007. /SYS/MB/CMP0/MCU2 Forced fail (IBIST)
Chassis | major: Dec 19 08:45:13 ERROR: MB/CMP0/MCU3 unused because
MB/CMP0/MCU2 is not configured
Chassis | major: Dec 19 08:45:13 ERROR: MB/CMP0/L2_BANK4,
MB/CMP0/L2_BANK5 unused because MB/CMP0/MCU2 is not configured
Chassis | major: Dec 19 08:45:13 ERROR: MB/CMP0/L2_BANK6,
MB/CMP0/L2_BANK7 unused because MB/CMP0/MCU3 is not configured
Chassis | major: Dec 19 08:45:13 ERROR: Degraded configuration:
system operating at reduced capacity
Chassis | major: Dec 19 08:45:13 ERROR: System DRAM Available:
008192 MB
Chassis | major: Dec 19 08:45:13 ERROR: Only 4 cores, up to 32 cpus
are configured because some L2_BANKS are unusable
```

Workaround: Install Patch 127580-04 or later, and update the System Firmware to version 7.0.9 or later.

## MCU Might Be Disconnected in DIMM Module Failure (CR 6656116)

This issue is resolved by updating the system firmware to 7.2.2.e or later.

If the DIMM module fails, the MCU will be disconnected, and the following message might be output to the console.

For example:

Message

```
Jun 04 06:11:22: Chassis |major   : "Jun  4 06:11:22 ERROR: MCU2
initialization failed: DRAM init, disabled"
Jun 04 06:11:23: Fault   |critical: "SP detected fault at time Wed
Jun  4 06:11:23 2008. /SYS/MB/CMP0/MCU2 Forced fail (DRAM init)"
Jun 04 06:11:24: Chassis |major   : "Jun  4 06:11:24 ERROR:
MB/CMP0/MCU3 unused because MB/CMP0/MCU2 is not configured"
Jun 04 06:11:24: Chassis |major   : "Jun  4 06:11:24 ERROR:
MB/CMP0/L2_BANK4, MB/CMP0/L2_BANK5 unused because MB/CMP0/MCU2 is
not configured"
Jun 04 06:11:24: Chassis |major   : "Jun  4 06:11:24 ERROR:
MB/CMP0/L2_BANK6, MB/CMP0/L2_BANK7 unused because MB/CMP0/MCU3 is
not configured"
Jun 04 06:11:24: Chassis |major   : "Jun  4 06:11:24 ERROR: Degraded
configuration: system operating at reduced capacity"
Jun 04 06:11:24: Chassis |major   : "Jun  4 06:11:24 ERROR: System
DRAM Available: 002048 MB"
```

showfaults command

```
Last POST Run: Wed Jun  4 06:14:17 2008
Post Status: Passed all devices
   ID FRU                Fault
   1 /SYS/MB             SP detected fault: /SYS/MB/CMP0/MCU2 Forced
fail (DRAM init)
```

Workaround: Identify and replace the faulty DIMM module.



## When the showenvironment Command is Executed in a Sixteen-Disk Capable Server, Even Though the Hard Disk is Mounted in Slot #8, "NOT PRESENT" is Output. (CR 6772707)

This issue is resolved by updating the system firmware to 7.2.2.e or later.

When the showenvironment command of ALOM CMT compatible shell is executed in a sixteen-disk capable server, even though the hard disk is mounted in slot #8, "NOT PRESENT" is output.

For example:

```
sc> showenvironment
:
(Omitted.)
:
-----
System Disks:
-----
Disk          Status          Service          OK2RM
-----
/SYS/HDD0     OK              OFF              OFF
/SYS/HDD1     OK              OFF              OFF
/SYS/HDD2     OK              OFF              OFF
/SYS/HDD3     OK              OFF              OFF
/SYS/HDD4     OK              OFF              OFF
/SYS/HDD5     OK              OFF              OFF
/SYS/HDD6     OK              OFF              OFF
/SYS/HDD7     OK              OFF              OFF
/SYS/HDD8     NOT PRESENT    OFF              OFF
/SYS/HDD9     OK              OFF              OFF
/SYS/HDD10    OK              OFF              OFF
/SYS/HDD11    OK              OFF              OFF
/SYS/HDD12    OK              OFF              OFF
/SYS/HDD13    OK              OFF              OFF
/SYS/HDD14    OK              OFF              OFF
/SYS/HDD15    OK              OFF              OFF
:
(Omitted.)
:
sc>
```

Workaround: The status can be confirmed from the ok prompt by using the probe-scsi-all command.

For example:

```
{0} ok probe-scsi-all
/pci@0/pci@0/pci@2/scsi@0
:
(Omitted.)
:
Target 8
Unit 0 Disk SEAGATE ST914602SSUN146G0603 286739329 Blocks,
146 GB
SASAddress 5000c5000b36a225 PhyNum 8
:
(Omitted.)
:
{0}
```

## For DC Input Power Models, the Output From the showpower -v Command May Differ Between /SYS/PS0 And /SYS/PS1 (CR 6802433)

This issue is resolved by updating the system firmware to 7.2.2.e or later.

For DC input power models, the INPUT limit value included in the output from the showpower -v command may differ between /SYS/PS0 and /SYS/PS1. The /SYS/PS1 value is correct.

[Example of showpower -v command execution]

```
sc> showpower -v
-----
Power Supplies:
-----
Supply          Status          INPUT          OUTPUT
                Status          Power          Power
                Status          (W)           (W)
-----
/SYS/PS0        OK              172.8          123.8
/SYS/PS1        OK              153.6          133.3
-----
Total Power          326.4
-----

Supply          INPUT          INPUT          INPUT          OUTPUT          OUTPUT          OUTPUT
                Volt          Current        limit         Volt          Current        limit
                (V)          (A)            (A)           (V)           (A)           (A)
-----
/SYS/PS0        -48.0         3.60           37.20         11.9          10.40          99.20
/SYS/PS1        -48.0         3.20           8.00(*)       11.9          11.20          99.20
-----
sc>
```

(\*) This is incorrect. The /SYS/PS0 value is correct.

Workaround: None. Ignore this issue because it is only a display error.

## In the Output From the `prtdiag` Command, Warnings May Be Displayed (CR 6821325)

This issue is resolved by updating the system firmware to 7.2.7.b or later.

In the output from the `prtdiag` command, warnings may be displayed for input voltage sensors(`V_IN_MAIN`) on power supply units.

```
Voltage sensors:
-----
Location                               Sensor                               Status
-----
SYS/MB/CMP0/MR0                        V_VMEM                              ok
SYS/MB/CMP0/MR0                        V_+1V5_VDD                          ok
SYS/MB/CMP1/MR1                        V_VMEM                              ok
SYS/MB/CMP1/MR1                        V_+1V5_VDD                          ok
SYS/MB                                  V_+3V3_STBY                         ok
SYS/MB                                  V_+3V3_MAIN                         ok
SYS/MB                                  V_+12V0_MAIN                        ok
SYS/MB                                  V_VDDIO                             ok
SYS/MB                                  V_VCOREL                            ok
SYS/MB                                  V_VCORER                             ok
SYS/MB                                  V_+1V5_IO                           ok
SYS/MB                                  V_VMEML                              ok
SYS/MB                                  V_VMEMR                              ok
SYS/MB                                  V_VBAT                              ok
SYS/PS0                                 V_IN_MAIN                            warning (-48volts)
SYS/PS0                                 V_OUT_MAIN                           ok
SYS/PS1                                 V_IN_MAIN                            warning (-48volts)
SYS/PS1                                 V_OUT_MAIN                           ok
```

Workaround: None. Ignore this issue because it is only a display error.

## During the Power-On Self-Test, the Diagnostic Process May Terminate Halfway (CR 6835860)

This issue is resolved by updating the system firmware to 7.2.7.b or later.

For SPARC Enterprise T5220 Server, during the power-on self-test (POST), the "ERROR:POST timed out" message may appear and the diagnostic process may terminate halfway.

Example:

```
sc> poweron -c
Enter #. to return to ALOM.
Chassis | major: Host has been powered on
0:0:0>
0:0:0>SPARC-Enterprise[TM] T5120/T5220 POST
4.30.2.build_06***PROTOTYPE BUILD***
2009/03/19 08:25

/export/delivery/delivery/4.30/4.30.2.build_06/post4.30.x/Niagara
/huron/integrated (root)
0:0:0>Copyright 2009 Sun Microsystems, Inc. All rights reserved
0:0:0>POST enabling CMP 0 threads: ffffffff.fffffff
0:0:0>VBSC mode is: 00000000.00000001
0:0:0>VBSC level is: 00000000.00000001
0:0:0>VBSC selecting Normal mode, MAX Testing.
0:0:0>VBSC setting verbosity level 2
0:0:0>Basic Memory Tests....Done
0:0:0>Test Memory....Done
0:0:0>Setup POST Mailbox ....Done
0:0:0>Master CPU Tests Basic....Done
0:0:0>Init MMU.....
0:0:0>NCU Setup and PIU link train....Done
0:0:0>L2 Tests....Done
0:0:0>Extended CPU Tests....-Chassis | major: Apr 21 10:51:09
ERROR: POST timed out. Not all system components tested.
Chassis | major: Host is running
```

Workaround: None. Power on the host again and perform the power-on self-test (POST).

## On the DC Input Power Model, the "Environmental Status" and Some Part of the "FRU Status" Information Is Not Displayed (CR 6853843)

This issue is resolved by updating the system firmware to 7.2.7.b or later.

On the DC input power model of SPARC Enterprise T5120 Server, when you execute the `prtdiag` command of Solaris OS, the "Environmental Status" and some part of the "FRU Status" information is not displayed.

Incomplete Data Output Example:

```
===== Environmental Status =====
<-- No data output.
===== FRU Status =====
Location                Name          Status
-----
SYS                      MB            enabled
SYS                      HDD0         enabled
SYS                      HDD1         enabled
<-- Part of data is not on display.
```

Workaround: None. From ILOM, check the component information and the status of fan, temperature, power sensor and so on.

# When the Service Processor Is Initialized, ILOM May Fails to Start With an Error Message Displayed (CR 6856163)

This issue is resolved by updating the system firmware to 7.2.7.b or later.

If the service processor is initialized (\*1) with the LAN cable disconnected from the ILOM network port, the ILOM firmware serial console window displays an error message (\*2) indicating a failure to start an ILOM internal process. As a result, ILOM fails to start.

(\*1) Service processor initialization has the following meaning:

- For ILOM

```
-> set /SP reset_to_defaults=all or factory
-> reset /SP
```
- For ALOM CMT compatible shell

```
sc> setdefaults
sc> resetsc
```

Example of failure:

```
SUNSP-BEL07482AU login: root
Password:
Waiting for daemons to initialize...

Timed out waiting for daemons to start      <-- (*2)
sccd daemon has shutdown                    <-- (*2)

Integrated Lights Out Manager

Version 3.0.3.20.e

Copyright 2009 Sun Microsystems, Inc. All rights reserved.
Use is subject to license terms.

Warning: password is set to factory default.

->
```

Workaround: Initialize the service processor with the LAN cable connected to the ILOM network port.

As long as the network port is linked up, the service processor can be initialized, even without ILOM network settings.

If this problem occurs, restore normal system operation by using the following procedure:

- 1. Disconnect the power cable.**
- 2. Connect the LAN cable to the ILOM network port.**  
**Verify that the ILOM network port is linked up.**
- 3. Connect the power cable.**



## After the SCC Module Replacement, a Connection to the ILOM Network May Fail (CR 6857271)

This issue is resolved by updating the system firmware to 7.2.7.b or later.

During SCC module replacement, part (\*1) of the data kept on the motherboard is inadvertently overwritten with new SCC module data (\*2). This results in a connection failure to the ILOM network.

(\*1) SCC module data including ILOM user data, network setting data, and diagnostics data. For details, see the ILOM Supplement for each server.

(\*2) The data is initialized at this point in time, so the data has no set values.

Also, the following type of log is output (\*) to the ILOM serial console window at the occurrence of the failure. sccd fails to start at ILOM startup:

Example of output to ILOM serial console at failure occurrence:

```
SUNSP-BEL07482AU login: root
Password:
Waiting for daemons to initialize...

Timed out waiting for daemons to start      <-- (*)
sccd daemon has shutdown                    <-- (*)

Integrated Lights Out Manager

Version 3.0.3.20.e

Copyright 2009 Sun Microsystems, Inc. All rights reserved.
Use is subject to license terms.

Warning: password is set to factory default.

->
```

Be sure to back up the service processor settings before replacing the SCC module.

Workaround: If only the SCC module fails, replace the SCC module together with the motherboard.

After replacing these components, restore the backed up contents.

---

# Solaris OS Issues

TABLE A-4 lists the Solaris OS issues that have been fixed.

**TABLE A-4** Fixed Solaris OS Issues

CR	Description	Workaround
6243759 (6479347)	The Solaris <code>prtdiag</code> command displays device paths incorrectly for <code>e1000g</code> driver devices.	<b>Note - Fixed in the Solaris 10 5/08 OS (and later) and in the Solaris 10 8/07 OS with patch ID 127127-11 or later installed.</b>  Force load all instances of the <code>e1000g</code> driver and then restart the <code>picld</code> daemon as follows: <pre># devfsadm -i e1000g # svcadm restart svc:/system/picl</pre> Another workaround is to use the <code>-r</code> option when booting or rebooting the system. You can also upgrade the OS or install the patch to avoid encountering this issue.
6527622	After the OS panic, the server may display the following message and stop at the <code>ok</code> prompt. WARNING: promif_ldom_setprop: ds response timeout WARNING: unable to store boot command for use on reboot	<b>Note - Fixed in Solaris patch ID 127111-05 or later.</b>  Set <code>auto-boot?=true</code> or use the <code>boot</code> command to start the server manually.
6536482	Currently, <code>cpumem</code> does not diagnose the <code>fbr/fbu</code> errors.	<b>Note - Fixed in Solaris patch ID 127127-11 or later.</b>
6552999	Performing a Control-C while the <code>prtdiag -v</code> command is running causes blank environmental data fields when run again. The missing output is persistent until the <code>picld</code> SMF service is restarted.	<b>Note - Fixed in the Solaris 10 10/08 OS or by installing patch ID 13094-01 or later.</b>  If the environmental data is missing from the <code>prtdiag</code> output, restart the <code>picld</code> SMF service in the control domain with the following command: <pre># svcadm restart picl</pre> You can also upgrade the OS or install the patch to avoid encountering this issue.

**TABLE A-4** Fixed Solaris OS Issues (*Continued*)

CR	Description	Workaround
6554813	During the transmission using the GLDv3 (Generic LAN Driver version 3) compliant Ethernet driver, if you execute the <code>ifconfig</code> command with the <code>modlist</code> ( <code>modinsert/modremove</code> ) option, the software ring procedure of GLDv3 module could cause a deadlock.	<b>Note - Fixed in Solaris patch ID 127127-11 or later.</b> Add the following entry to the <code>/etc/system</code> file and reboot the system. <b>set ip:ip_soft_rings_cnt=0</b>
6555956	Servers might experience panics generated from the PCIe root complex. A panic could occur during reboot with the following message: "Fatal error has occurred in: PCIe root complex." The panic only occurs during a reboot and has never been observed during a reboot that follows the panic. The panic can occur even if no external USB devices are connected to the server.	<b>Note - This issue is resolved for servers running the Solaris 10 5/08 OS or later.</b> If your server experiences this panic, perform the workarounds described in " <a href="#">Servers Might Experience Panics Generated From the PCIe Root Complex (CR 6555956)</a> " on page 122. If you are not running the Solaris 10 10/08 OS, this issue is also resolved by installing patch ID 128304-03 or later.
6566442	The <code>prtdiag</code> command output may be incorrect <ul style="list-style-type: none"><li>Information of memory is displayed as left aligned.</li><li>Though the CPU threads have been disabled, the FRU Status shows "All FRUs are enabled"</li><li>Information of a FAN replaced by hot swapping is not displayed.</li><li>Some of the memory configuration information is not displayed.</li></ul>	<b>Note - Fixed in Solaris patch ID 127127-11 or later.</b> None.
6572985	During long SunVTS test runs, the SunVTS <code>cryptotest</code> could fail intermittently with an error similar to the following: "cryptotest.FATAL n2rng0: SUNW_RANDOM generate failed: values generated fall outside statistical tolerance"	<b>Note - Fixed in Solaris patch ID 139667-01 or later.</b> Install the SunVTS Patch number 127294-01 (or later).
6578410	The server might hang when trying to boot with an Infiniband HBA card installed.	<b>Note - Fixed in the Solaris 10 5/08 OS (and later) and in the Solaris 10 8/07 OS with patch ID 127127-11 or later installed.</b> Add the following setting to the <code>/etc/system</code> file: <code>set tavor:tavor_iommu_bypass = 0</code> You can also upgrade the OS or install the patch to avoid encountering this issue.

**TABLE A-4** Fixed Solaris OS Issues (*Continued*)

CR	Description	Workaround
6586624	<p>The Solaris <code>prtdiag</code> and <code>prtpicl</code> commands might not display complete information, as follows:</p> <ul style="list-style-type: none"> <li>• If the <code>prtdiag -v</code> option is specified, the firmware version and the chassis serial number might not be displayed.</li> <li>• The <code>prtpicl</code> command will not always display the physical-platform section.</li> </ul>	<p><b>Note - Fixed in System Firmware 7.0.9 or later.</b></p> <p>Use alternative methods to obtain the information you need as described in <a href="#">“Information Missing From <code>prtpicl</code> and <code>prtdiag</code> Commands (CR 6586624)”</a> on page 123.</p> <p>You can also update the System Firmware to the latest version to avoid encountering this issue.</p>
6586847	<p>The Solaris <code>prtdiag</code> command without the <code>-v</code> option does not show failures in the output.</p>	<p><b>Note - Fixed in the Solaris 10 5/08 OS (and later) and in the Solaris 10 8/07 OS with patch ID 127127-11 or later installed.</b></p> <p>Use the <code>-v</code> option when running the <code>prtdiag</code> command.</p> <p>You can also upgrade the OS or install the patch to avoid encountering this issue.</p>
6587389	<p>The Solaris <code>prtdiag -v</code> command might display information with missing spaces, making the output difficult to read.</p>	<p><b>Note - Fixed in the Solaris 10 5/08 OS (and later) and in the Solaris 10 8/07 OS with patch ID 127127-11 or later installed.</b></p> <p>Use the <code>showenvironment</code> command from the ALOM CMT compatibility CLI as follows:</p> <pre>sc&gt; showenvironment</pre> <p>For more details, see <a href="#">“The <code>prtdiag -v</code> Command Has Formatting Issues (CR 6587389)”</a> on page 125.</p> <p>You can also upgrade the OS or install the patch to avoid encountering this issue.</p>
6588452	<p>Booting the Solaris OS from an external USB DVD-ROM drive could cause a panic and fail to boot.</p> <p>For more information, see <a href="#">“Booting the Solaris OS From an External USB DVD-ROM Drive Could Cause a Panic (CR 6588452)”</a> on page 124.</p>	<p><b>Note - Fixed in the Solaris 10 5/08 OS (and later) and in the Solaris 10 8/07 OS with patch ID 127127-11 or later installed.</b></p> <p>Use the built-in DVD drive, or use a drive whose subclass is not 2, 3, or 4.</p> <p>You can also upgrade the OS or install the patch to avoid encountering this issue.</p>
6588550	<p>The Solaris <code>prtdiag -v</code> command is slow to respond on the SPARC Enterprise T5120 servers. The command might take as long as 5 minutes to display output and therefore appears to hang.</p>	<p><b>Note - Fixed in Solaris patch ID 138502-01 or later.</b></p> <p>Be aware of the delay, and wait for the output. Do not perform a Control-C.</p>

**TABLE A-4** Fixed Solaris OS Issues (*Continued*)

CR	Description	Workaround
6589612	<p>The <code>raidctl -l</code> command continuously outputs the following output:</p> <pre># raidctl -l Controller: 1     Volume:c1t0d0     Volume:c1t2d0 Disk: 0.0.0 Disk: 0.0.0 ...</pre>	<p><b>Note - Fixed in the Solaris 10 5/08 OS (and later) and in the Solaris 10 8/07 OS with patch ID 127127-11 or later installed.</b></p> <p>Use the Control-C keyboard sequence to stop the output.</p> <p>You can also upgrade the OS or install the patch to avoid encountering this issue.</p>
6592238	<p>You might not be able to remove a RAID 1 volume after RAID 1 and RAID 0 volumes are created.</p> <p>When two volumes are created through the onboard SAS controller (or any controller that uses the <code>mpt</code> driver), the <code>raidctl</code> utility is unable to delete one of the RAID volumes and cannot list the correct disk information. When this occurs, the following is the error message is displayed:</p> <pre># raidctl -l Device record is invalid.</pre>	<p><b>Note - Fixed in the Solaris 10 5/08 OS (and later) and in the Solaris 10 8/07 OS with patch ID 127127-11 or later installed.</b></p> <p>Update the OS to the latest version or install the mandatory patches to avoid encountering this issue in the future.</p>
6594506	<p>After certain hardware error events, it is possible that Solaris PSH events are no longer transported between the SP and the domain.</p> <p>For examples, see <a href="#">“PSH Events Are no Longer Transported (CR 6594506)”</a> on page 125.</p>	<p><b>Note - Fixed in the Solaris 10 5/08 OS (and later) and in the Solaris 10 8/07 OS with patch ID 127127-11 or later installed.</b></p> <p>See <a href="#">“PSH Events Are no Longer Transported (CR 6594506)”</a> on page 125.</p> <p>You can also upgrade the OS or install the patch to avoid encountering this issue.</p>
6596503	<p>The output of the Solaris <code>prtpicl -v</code> command might show CPU cores or strands with an operational status of <code>enabled</code> when the cores or strands do not exist.</p>	<p><b>Note - Fixed in System Firmware 7.1.6.d or later.</b></p> <p>Instead, use the output from the <code>prtdiag</code> or <code>prtpicl -c cpu</code> commands.</p> <p>You can also update the System Firmware to the latest version to avoid encountering this issue.</p>

**TABLE A-4** Fixed Solaris OS Issues (*Continued*)

CR	Description	Workaround
6581309	<p>The selection message, <code>r)ebook, o)k prompt, h)alt?</code>, appears on the OS console; but if you select “o”, you might see the following messages.</p> <p>Example 1:</p> <pre>r)ebook, o)k prompt, h)alt? o WARNING: promif_ldom_setprop: ds response timeout</pre> <p>Example 2:</p> <pre>r)ebook, o)k prompt, h)alt? o WARNING: promif_ldom_setprop: ds response timeout WARNING: LDOMs Variable Update request failed! NOTICE: Unable to complete Domain Service protocol version handshake WARNING: Unable to connect to Domain Service providers WARNING: Unable to update LDOM Variable</pre>	<p><b>Note - Fixed in Solaris patch ID 137111-01 or later.</b></p> <p>These messages have no effect on your server. Apply patch ID 137111-01 (or later).</p>
6601028	<p>The LEDs of TX (data transmitting) and RX (data receiving) on XAUI Card do not show correct status of data transmission.</p>	<p><b>Note - Fixed in Solaris patch ID 137137-09 or later.</b></p> <p>Please ignore these LED’s status.</p>

## Servers Might Experience Panics Generated From the PCIe Root Complex (CR 6555956)

This issue is resolved for servers running the Solaris 10 5/08 OS or later.

A panic could occur during reboot with the following message:

```
"Fatal error has occurred in: PCIe root complex."
```

The panic only occurs during a reboot and has never been observed during a reboot that follows the panic. The panic can occur even if no external USB devices are connected to the server.

Workarounds:

If your server experiences this panic, perform one or more of the following workarounds:

- To ensure that the system reboots and continues to function after a panic, configure the server to automatically reboot using one of the following methods:

- Using the ILOM CLI:

```
-> set /HOST/bootmode script="setenv auto-boot? true"  
-> set /HOST/bootmode script="setenv auto-boot-on-error? true"
```

- Using the ALOM CMT compatibility CLI:

```
sc> bootmode bootscript="setenv auto-boot? true"  
sc> bootmode bootscript="setenv auto-boot-on-error? true"
```

- To eliminate the possibility of the panic, disable the USB (only perform this workaround if you do not use USB devices, including the built-in DVD drive):
  - Using the ILOM CLI:

```
-> set /SYS/MB/PCIE-IO/USB component_state=Disabled
```

- Using the ALOM CMT compatibility CLI:

```
sc> disablecomponent /SYS/MB/PCIE-IO/USB
```

All devices on the USB will be disabled, including the DVD drive. Be aware that the service processor will generate a fault and turn on the fault LED.

If you need to enable the USB, use the following commands:

- Using the ILOM CLI:

```
-> set /SYS/MB/PCIE-IO/USB component_state=Enabled
```

- Using the ALOM CMT compatibility CLI:

```
sc> enablecomponent /SYS/MB/PCIE-IO/USB
```

## Information Missing From `prtpicl` and `prtdiag` Commands (CR 6586624)

This issue is resolved by updating the system firmware to 7.0.9 or later.

The `prtdiag` command might not display environmental and FRU status. If the `-v` option (verbose) is specified, the firmware version and the chassis serial number might not be displayed.

In addition, the `prtpicl` command might not display the physical-platform section.

Use one of the following alternative methods to obtain missing information:

- Alternative for the `prtdiag` command – Use the following ALOM CMT compatibility CLI commands:

```

sc> showenvironment - displays the system's environmental status
sc> showfru component NAC - displays a component's FRU status
sc> showplatform - displays the Chassis Serial Number
sc> showhost - displays the firmware version

```

- Alternative for the `prtpicl` command – Walk through the targets of the `show SYS` command with the ILOM CLI and the ILOM graphical user interface. Refer to the *Integrated Lights Out Manager (ILOM) 2.0 User's Guide* for details.

## Booting the Solaris OS From an External USB DVD-ROM Drive Could Cause a Panic (CR 6588452)

This issue is resolved for servers running the Solaris 10 5/08 OS and later. If you are running Solaris 10 8/07, you can fix this issue with patch ID 127127-11 or later.

Booting the Solaris 10 OS from an external USB DVD-ROM drive could panic the server and fail to boot the OS. This situation happens because the Solaris OS names the device `storage@1`, and the System Firmware names the device `cdrom@1`.

Both the OpenBoot firmware and Solaris OS follow the 1275 USB bindings rules to name nodes. For example:

**TABLE :** 1275 USB Bindings Rules for Naming Nodes

<b>bInterface Class</b>	<b>bInterface Subclass</b>	<b>bInterface Protocol</b>	<b>Name</b>
0x08	1	Any	storage
0x08	2	Any	cdrom
0x08	3	Any	tape
0x08	4	Any	floppy
0x08	5	Any	storage
0x08	6	Any	storage
0x08	Any	Any	storage

The Solaris 10 OS always names the node as `storage@n`. Therefore, the storage device with a subclass of 2, 3, or 4 (SPARC Enterprise T5120 and T5220 must be 2) cannot boot with Solaris 10 OS DVD.



Workaround: Use the drive whose subclass is not 2, 3, or 4 as the replacement.

## The `prtdiag -v` Command Has Formatting Issues (CR 6587389)

This issue is resolved for servers running the Solaris 10 5/08 OS and later. If you are running Solaris 10 8/07, you can fix this issue with patch ID 127127-11 or later.

Some of the information displayed by the `prtdiag(1M)` command is difficult to read when the `-v` option is used. White space is missing between the first and second fields in the report.

The following formatting issues are displayed in the `prtdiag -v` command output:

- *Fans sensors* – Missing spaces tab between Location and Sensor columns.
- *Temperature sensors* – DIMMs missing spaces tab between Location and Sensor columns.
- *LEDs* – Location missing for SERVICE, LOCATE, ACT, PS\_FAULT, TEMP\_FAULT, and FAN\_FAULT DIMMs. Missing spaces tab between Location and LED.
- Locations of sensors – have the first portion of their location truncated, resulting in no location being reported for some items such as system status LEDs.

To see this formatting information, use the `showenvironment` command in the ALOM CMT compatibility CLI:

```
sc> showenvironment - displays the system environmental status
```

## PSH Events Are no Longer Transported (CR 6594506)

This issue is resolved for servers running the Solaris 10 5/08 OS and later. If you are running Solaris 10 8/07, you can fix this issue with patch ID 127127-11 or later.

After certain hardware error events, it is possible that PSH events are no longer transported between the service processor (SP) and the domain. The following scenarios are subject to this problem:

- In a non-LDoms environment, an unrecoverable error occurs in the Solaris domain.
- In an LDoms environment, an unrecoverable error occurs in the control domain.
- In either an LDoms or non-LDoms environment, a fatal error occurs in the system (a fatal error resets the system at the hardware level).

---

**Note** – In an LDom environment, unrecoverable errors in a uncontrolled LDom guest domain are *not* subject to this problem.

---

For example, an unrecoverable error in the control domain causes Solaris to panic. Messages similar to the following are reported to the control domain console:

```
SUNW-MSG-ID: SUNOS-8000-0G, TYPE: Error, VER: 1, SEVERITY: Major
EVENT-TIME: 0x46c61864.0x318184c6 (0x1dfeda2137e)
PLATFORM: SUNW,SPARC-Enterprise-T5220, CSN: -, HOSTNAME: wgs48-100
SOURCE: SunOS, REV: 5.10 Generic_Patch
DESC: Errors have been detected that require a reboot to ensure system
integrity. See http://www.sun.com/msg/SUNOS-8000-0G for more information.
AUTO-RESPONSE: Solaris will attempt to save and diagnose the error telemetry
IMPACT: The system will sync files, save a crash dump if needed, and reboot
REC-ACTION: Save the error summary below in case telemetry cannot be saved
```

Or, an unrecoverable error causes the firmware to abort and messages similar to the following are reported to the SP console when logged into the ALOM CMT compatibility CLI console:

```
Aug 17 22:09:09 ERROR: HV Abort: <Unknown?> (228d74) - PowerDown
```

After the control domain recovers, a diagnosis is performed. Messages to the console indicate the cause of the unrecoverable error. For example:

```
SUNW-MSG-ID: SUN4V-8000-UQ, TYPE: Fault, VER: 1, SEVERITY: Critical
EVENT-TIME: Fri Aug 17 18:00:57 EDT 2007
PLATFORM: SUNW,SPARC-Enterprise-T5220, CSN: -, HOSTNAME: wgs48-100
SOURCE: cpumem-diagnosis, REV: 1.6
EVENT-ID: a8b0eb18-6449-c0a7-cc0f-e230a1d27243
DESC: The number of level 2 cache uncorrectable data errors has exceeded
acceptable levels. Refer to http://sun.com/msg/SUN4V-8000-UQ for more
information.
AUTO-RESPONSE: No automated response.
IMPACT: System performance is likely to be affected.
REC-ACTION: Schedule a repair procedure to replace the affected resource,
the identity of which can be determined using fmdump -v -u <EVENT_ID>.
```

At this point, the problem might have been encountered. This problem will prevent future PSH events (for example, new hardware errors, correctable or uncorrectable) from being transported into the domain and properly diagnosed.

Workaround: After the domain recovers and the diagnosis message is printed to the Solaris console, reset the service processor as follows:

```
sc> resetsc -y [ALOM CMT compatibility CLI]
OR
-> reset /SP [ILOM CLI]
```

Once the SP is restarted and you are able to log in as the admin (which means all daemons are ready), type the following in the Solaris control domain:

```
# fmadm unload etm
# fmadm load /usr/platform/sun4v/lib/fm/fmd/plugins/etm.so
```

---

# LDoms Related Issues

TABLE A-5 lists the LDoms related issues that have been fixed.

TABLE A-5 Fixed LDoms Related Issues

CR	Description	Workaround
6543749	<p>A guest domain wanboot <code>miniroot</code> download could take more than 30 minutes.</p> <p>During boot or installation over wide area networks, the time it takes to download the <code>miniroot</code> could significantly increase when using a virtual network device.</p> <p>This performance degradation is relevant only when trying to boot or install over wide area networks using a virtual network device. A similar boot or installation using a physical network device works as expected, as does a traditional local area net boot, or installing from a virtual network device.</p>	<p><b>Note - Fixed in System Firmware 7.1.0.g or later.</b></p> <p>Be aware of the time needed to boot or perform installations over a wide area network with a virtual network device.</p> <p>You can also update the System Firmware to the latest version to avoid encountering this issue in the future.</p>
6567748	<p>Domain status might not be reported accurately. For example, the status reported for a domain might be <code>Running</code> when the OS is not running. This problem is encountered when the domain status is reported by ILOM (BI and CLI) and from the ALOM CMT compatibility <code>showplatform</code> command.</p> <p>The ambiguity also exists in the ILOM control MIB, but not in the platform entity MIB. Thus, the ambiguous domain status might be visible to third-party systems monitoring tools if they monitor this entry.</p>	<p><b>Note - Fixed in System Firmware 7.1.0.g or later.</b></p> <p>Ignore the domain status information from all CLIs and BI output as well as from the domain status entry in the ILOM control MIB. Retrieve the true status of the domain by accessing the domain console.</p> <p>You can also update the System Firmware to the latest version to avoid encountering this issue in the future.</p>

**TABLE A-5** Fixed LDOMs Related Issues (*Continued*)

CR	Description	Workaround
6592934	<p>In the unlikely event that POST times out before completing its test cycle, the firmware issues the following message to the console:</p> <pre>ERROR: POST timed out. Not all system components tested.</pre> <p>The system continues to boot, but in a degraded state. During the boot process the following error messages are displayed:</p> <pre>WARNING: Unable to connect to Domain Service providers WARNING: Unable to get LDOM Variable Updates WARNING: Unable to update LDOM Variable</pre> <p>Any programs or services that depend on an LDC channel run in a degraded state, or not at all. Some programs that require LDC to function are <code>ldmd</code>, <code>fmd</code>, and <code>eeprom</code>.</p>	<p><b>Note - Fixed in System Firmware 7.1.0.g or later.</b></p> <p>If the error is observed on the console during boot, power cycle the system, and ensure that POST runs to completion.</p> <p>You can also boot without running POST.</p> <p>You can also update the System Firmware to the latest version to avoid encountering this issue in the future.</p>
6593132	<p>Changes to OpenBoot PROM variables with non-default LDOMs configuration do not persist. If an LDOMs variable is set to a non-default value when an LDOMs configuration is saved to the service processor, and then later changed back to its default value, the change to its default value will not persist after a power cycle.</p>	<p><b>Note - Fixed in System Firmware 7.0.9 or later.</b></p> <p>Save the SP configuration after changing an LDOMs variable. Example:</p> <pre># ldm remove-spcnfig my-new-config # ldm add-spcnfig my-new-config</pre> <p>You can also update the System Firmware to the latest version to avoid encountering this issue in the future.</p>
6594395	<p>The <code>ldm set-variable</code> command allows you to set an LDOMs variable to any arbitrary string. If an LDOMs variable is set to a value that is not valid, the OpenBoot firmware issues a warning message during boot with a list of correct values, but without giving the name of the variable in question.</p>	<p><b>Note - Fixed in System Firmware 7.1.0.g or later.</b></p> <p>For more information, refer to the <i>Logical Domains (LDoms) 1.0.1 Release Notes</i>.</p> <p>You can also update the System Firmware to the latest version to avoid encountering this issue in the future.</p>

**TABLE A-5** Fixed LDoms Related Issues (*Continued*)

CR	Description	Workaround
6597761	<p><code>rm-io</code> followed by multiple <code>set-vcpu</code> operations might cause the firmware to abort or <code>ldmd</code> core dump.</p> <p>During a single delayed reconfiguration operation, do not attempt to add CPUs to a domain if any CPUs were previously removed during the same delayed reconfiguration.</p>	<p><b>Note - Fixed in System Firmware 7.0.9 or later.</b></p> <p>Either cancel the existing delayed reconfiguration first (if possible), or commit it (by rebooting the target domain), and then apply the CPU addition.</p> <p>Failure to heed this restriction can, under certain circumstances, lead to the firmware returning a parse error to the LDoms Manager, resulting in the LDoms Manager aborting. Additionally, if any VIO devices had been removed during the same delayed reconfiguration operation, when the LDoms manager restarts after the abort, it incorrectly detects the need to perform a recovery operation. This situation results in a corrupt configuration, followed by a power down.</p> <p>You can also update the System Firmware to the latest version to avoid encountering this issue in the future.</p>



  
FUJITSU