



INSTRUCTIONS

-J06102

REV. 2014-07-30

SCREAMIN' EAGLE PERFORMANCE AIR CLEANER KIT

GENERAL

Kit Numbers

29400220, 29400221

Models

For model fitment information, see the P&A retail catalog or the Parts and Accessories section of www.harley-davidson.com (English only).

Installation Requirements

Proper installation of this kit requires the use of Digital Technician® by a factory-trained technician at a Harley-Davidson dealer.

This kit requires the use of Loctite® 243 Threadlocker and Sealant - Blue (Part No. 99642-97) and is available from a Harley-Davidson dealer.

⚠ WARNING

The rider's safety depends upon the correct installation of this kit. Use the appropriate service manual procedures. If the procedure is not within your capabilities or you do not have the correct tools, have a Harley-Davidson dealer perform the installation. Improper installation of this kit could result in death or serious injury. (00333a)

NOTE

This instruction sheet refers to service manual information. A service manual for this year/model motorcycle is required for this installation. One is available from a Harley-Davidson dealer.

Kit Contents

See Figure 1 and Table 1.

NOTE

The kit is intended for High Performance applications only. Engine-related performance parts are intended FOR THE EXPERIENCED RIDER ONLY.

This engine-related performance part is legal for sale or use in California on pollution controlled motor vehicles. The Product Information Label contained in this kit is a requirement of the California Air Resource Board (CARB) emission regulation. Place the label on the right side of the frame directly beneath the VIN sticker. This label is not required outside the state of California.

Installation of this kit by an authorized Harley-Davidson dealer will not impact your limited vehicle warranty.

REMOVAL

⚠ WARNING

To prevent accidental vehicle start-up, which could cause death or serious injury, remove main fuse before proceeding. (00251b)

1. Remove main fuse. Refer to the service manual.
2. **FL Touring models:** Remove the fuel tank per the service manual.
3. Remove and recycle or properly dispose of the currently installed air cleaner. Refer to the service manual or the instructions.
4. See Figure 1 and Table 1. Remove and recycle or properly dispose of the induction module support bracket (A).

INSTALLATION

Install Air Cleaner

NOTE

When servicing the air cleaner, apply Loctite® 243 (blue) to all fasteners.

1. See Figure 1. Install two O-rings (1) from kit in grooves around breather screw holes on induction module side of backplate assembly (2).
Install two O-rings (1) from kit in grooves in underside of head of breather screws (5).
2. Peel the protective strip off the gasket (3) and place the adhesive side onto the backplate. Align to the equally spaced screw holes, and position the gasket carefully before firmly pressing the gasket into place.
3. Apply Loctite 243 (blue) to breather screw threads and mating tapped holes in cylinder head.
4. Insert new breather screws (5) through the backplate.
5. Install screws into the cylinder head but do not tighten.
6. Install air cleaner mounting screws (4) through the mounting bracket (6) and into the backplate (2) until the screw threads are captured in induction module. Leave fasteners loose.
7. Alternately tighten two breather screws (5) to 120-144 **in-lbs** (13.6-16.3 Nm).
8. Tighten three air cleaner screws (4) to 55-60 **in-lbs** (6.2-6.8 Nm).
9. **FL Touring models:** Install fuel tank per service manual instructions.

Install air cleaner filter and cover.

NOTE

Whenever the air cleaner cover is installed, apply Loctite 243 (blue) to the air cleaner cover screw (8).

1. See Figure 1. Install the air cleaner element (7), air filter screen (11), and cover (9). Before tightening the center screw, align the cover using the medallion for best appearance. Tighten center screw to 36-60 **in-lbs** (4.1-6.8 Nm).

NOTE

Apply a small amount of dish soap to medallion O-ring to aid in installation of medallion.

2. Install the medallion into the center hole by pressing in place. Do not damage the O-ring.

Completion

NOTE

Verify that the ignition key switch is in the OFF position **before** installing the main fuse.

1. Install the main fuse. See the service manual.

NOTES

Install the rain sock over the air filter element in wet or rainy conditions to prevent water intrusion.

Install the pre-charger (13) over the air filter element under these circumstances.

Recalibrate ECM

NOTICE

You must recalibrate the ECM when installing this kit. Failure to properly recalibrate the ECM can result in severe engine damage. (00399b)

Have a Harley-Davidson dealer install the new ECM calibration using Digital Technician™.

Air Filter Element Maintenance

1. Inspect the air filter element every 5000 miles (8000 km), or more often under dusty conditions.

NOTES

- The use of cleaning, drying or oiling methods or products other than those shown damages the filter and void the manufacturer's warranty
- K&N® Air filter Cleaner is available from a Harley-Davidson dealer, either alone (1 qt/0.95 L sprayer bottle, Part No.

99883-88T). Or, a 12 fl oz/0.35 L sprayer bottle as part of the Filter Care Service Kit (Part No. 99850-92T).

- K&N Air Filter Oil is also available from a Harley-Davidson dealer, either alone (12.25 oz/347 gram aerosol can, Part No. 99882-88T). Or, a 6.5 oz/184 gram aerosol can as part of the Filter Care Service Kit.
 - **DO NOT OVER-OIL THE AIR FILTER.** Over-oiling can interfere with the proper performance of the engine and/or certain engine components. If oil is still draining or dripping from the filter media 20 minutes after oiling, clean and oil the filter element again.
2. To clean the element:
 - a. Remove the center medallion by inserting a small flat blade screwdriver in the slot at the bottom of the medallion. Carefully work around the center portion without scratching the finish of the air cleaner cover. Rotating the medallion aids in removal.
 - b. Remove the air cleaner cover center screw.
 - c. Tap the element to dislodge any loose dirt. Gently brush with a soft bristle brush.
 - d. Spray air filter cleaner liberally onto the cotton filter media and let soak for ten minutes. Or, roll and soak the cotton filter media in a shallow pan of air filter cleaner. Remove immediately, and let soak for ten minutes.
 - e. Rinse off the filter media (flowing from the **clean** side to the dirty side), with low-pressure tap water.
 - f. After rinsing, shake off all excess water, and let the filter media air dry. **DO NOT** use compressed air or a heat gun to speed drying.
 - g. After the filter media is dry, EITHER spray air filter oil along each pleat, once only, holding the spray nozzle approximately 3 in (76 mm) away from the media. Or, carefully use a squeeze bottle to deposit oil along each pleat, once only.

Let the oil absorb into the filter media for 20 minutes before proceeding.

After 20 minutes, inspect the filter media. Carefully apply oil to any remaining visible white spots on the filter media. Allow to absorb.

SERVICE PARTS

is07256a

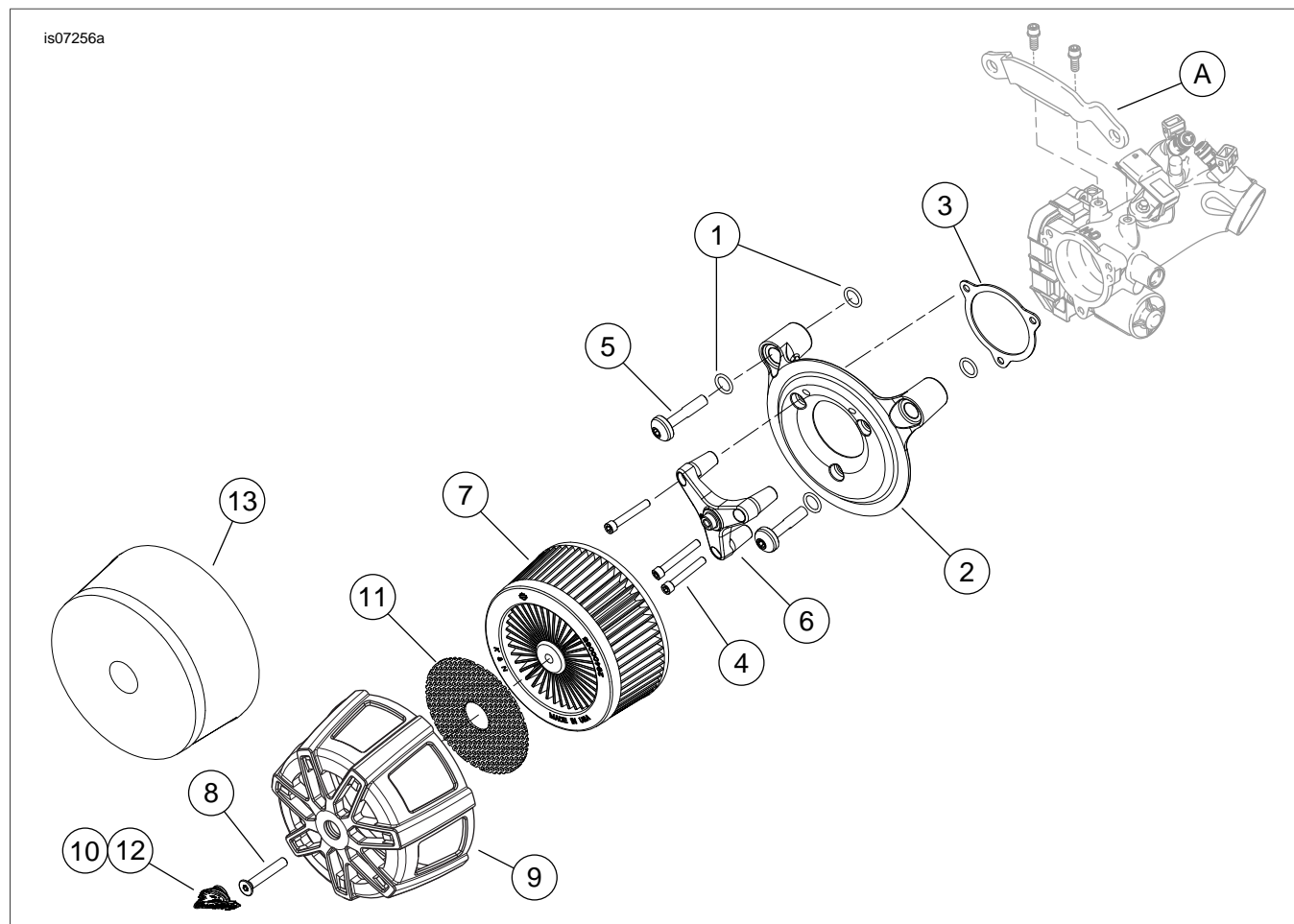

Figure 1. Service Parts, Screamin' Eagle Performance Air Cleaner Kit

Table 1. Service Parts

Item	Description (Quantity)	Part Number
1	O-ring, #2-113 (4)	11292
2	Backplate, chrome (Kit 29400123) Backplate, black (Kit 29400124)	29000080 29000079
3	Gasket, throttle body	29241-08
4	Screw, socket head cap, 1/4-20 x 1.75 in (44.5 mm) long (3)	Not sold separately
5	Bolt, breather (2)	29400081
6	Bracket, mounting	29400072
7	Air filter element	29400065
8	Screw, hex socket, flat head, 5/16-18 x 2.0 in (51 mm) long	Not sold separately
9	Cover, air cleaner	Not sold separately
10	Medallion, Screamin' Eagle	14100367
11	Screen, air filter, chrome (Kit 29400221) Screen, air filter, black (Kit 29400220)	29400082 29400100
12	O-ring, medallion	11170
13	Pre-charger	29400121
Items mentioned in text, but not included in kit:		
A	Induction module bracket	