

Service Parts

Marine Generator Sets



Models:

3.5-5EFZ

4-6.5ESZ

KOHLER[®]
POWER SYSTEMS

ISO 9001
KOHLER
GENERATORS
INTERNATIONALLY REGISTERED
U.S.A. Plant ISO Registered

Specification Series 125

TP-5833 8/99a

Introduction

This manual contains a list of generator and some engine service replacement parts for Kohler marine generator sets. Refer to the Specification Number Index for models and specifications covered.

This manual includes the following main sections:

- *Table of Contents*: Lists the sections of this catalog.
- *Introduction (and other information sections)*: Contains introductory material followed by sections on specification numbers, part numbers, and hardware.
- *Index*: Indexes generator set specifications and their groups.
- *Group Parts Lists*: Lists part numbers of parts in the groups.
- *Kit sections*: Lists accessories, and their parts.
- *Appendices*: Includes Glossary of Abbreviations, Common Hardware Application Guidelines, Common Hardware Identification, General Torque Specifications, and Common Hardware List.

Number Significance

This catalog uses a variety of numbering systems. A description of these follows:

- *Specification Number*: The generator specification number (spec number) is six digits with a PA-, PB-, or PE-prefix (Specification Number Index does not show prefixes). The first three digits designate generator size and engine model (specification series). The remaining digits are in sequence and identify a particular spec in a series. Spec numbers break down into groups.
- *Group Number*: A group consists of parts needed to perform one or more related functions. For example, the 101 group is the generator set Air Intake group.
- *Variation Number*: A group might have several variations. Parts comprising each variation perform the same function, but parts lists vary. For example, a 50 Hz generator alternator and 60 Hz generator alternator both perform the same function. However, they are constructed of different parts. Each of these differences necessitates the assignment of a group variation number.
- *Part Number*: The part number identifies an individual assembly, subassembly, component, or accessory kit.

How to Find Part Numbers

FOLLOW THESE STEPS to identify a part:

STEP 1: Turn to the Specification Number Index. The first column lists generator set specification numbers grouped by model. The headings across the top identify the groups of parts that make up the generator set. The intersection of the specification number and the group numbers is the

variation number corresponding to the components of that specification number. Note the variation number.

STEP 2: Find the page number of the group in the Table of Contents and turn to that page or page forward until you find the group. Variation numbers in the column heading of the group page correspond to variations found in the Specification Number Index. Find the description of the part you need in the description column. The intersection of the description row with the variation column identifies the quantity of that part used in that group. Find the part number to order to the left of the description in the part number column.

Hardware Grades

When replacing hardware do not substitute inferior grade hardware. All hex. head screws are hardness grade 5, except where noted. Socket head screws are similar to grade 8. All replacement hardware should be at least equal to original manufacturer's hardware quality. Refer to Common Hardware Application Guidelines and Common Hardware Identification in the back of the manual.

Hardware References

Many common hardware items will appear in parts catalogs as common hardware entries or hardware references. A common hardware entry refers to the size of common hardware to apply in accordance with hardware guidelines. For example, an item may appear as "3/8-16 hardware" in the text. It indicates that the piece is 3/8-16 size. See Common Hardware Application Guidelines.

A hardware reference has the abbreviation "ref." in the part's description. Hardware references specify common hardware items; however, size or some other characteristic requires specification in that application. For example, item 1 in Figure 1 below might appear in the text as follows:

Screw, 3/8-16 x 1, ref. X-6021-1

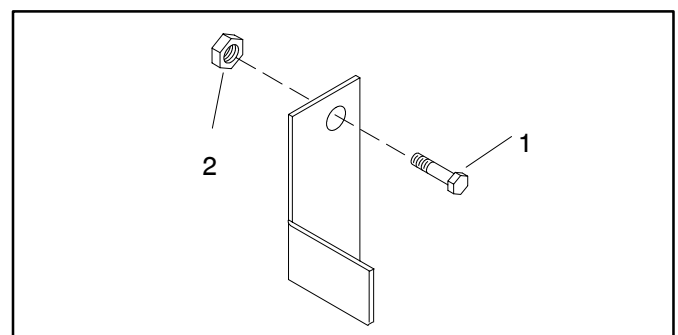

Figure 1. Hardware References

Specification Number Index

GROUP TITLE & NUMBER	<i>Cylinder Head Cover</i>	<i>Cylinder Head</i>	<i>Cylinder Barrel</i>	<i>Thermostat</i>	<i>Oil Pump</i>	<i>Crankshaft & Piston</i>	<i>Timing Belt Cover & Water Pump</i>	<i>Flywheel</i>	<i>Ignition Coil</i>	<i>Starter Motor</i>	<i>Governor Arm & Balancer Weight</i>	<i>Engine Mount Stay</i>	<i>Front Housing</i>	
GROUP NO.	B1	B2	B4	B6	B7	B8	B10	C3	C4	C5	C6	C7	C8	
SPEC NO.	VARIATION NUMBER													
125237	1	1	1	1	1	1	1	1	1	1	1	1	1	
125238	1	1	1	1	1	1	1	1	1	1	1	1	1	
125239	1	1	1	1	1	1	1	1	1	1	1	1	1	
125240	1	1	1	1	1	1	1	1	1	1	1	1	1	
125241	1	1	1	1	1	1	1	1	1	1	1	1	1	
125242	1	1	1	1	1	1	1	1	1	1	1	1	1	
125243	1	1	1	1	1	1	1	1	1	1	1	1	1	
125244	1	1	1	1	1	1	1	1	1	1	1	1	1	
125245	1	1	1	1	1	1	1	1	1	1	1	1	1	
125246	1	1	1	1	1	1	1	1	1	1	1	1	1	
125247	1	1	1	1	1	1	1	1	1	1	1	1	1	
125248	1	1	1	1	1	1	1	1	1	1	1	1	1	
125249	1	1	1	1	1	1	1	1	1	1	1	1	1	
125250	1	1	1	1	1	1	1	1	1	1	1	1	1	
125251	1	1	1	1	1	1	1	1	1	1	1	1	1	
125252	1	1	1	1	1	1	1	1	1	1	1	1	1	
125253	1	1	1	1	1	1	1	1	1	1	1	1	1	
125254	1	1	1	1	1	1	1	1	1	1	1	1	1	
125255	1	1	1	1	1	1	1	1	1	1	1	1	1	
125256	1	1	1	1	1	1	1	1	1	1	1	1	1	
125257	1	1	1	1	1	1	1	1	1	1	1	1	1	
125258	1	1	1	1	1	1	1	1	1	1	1	1	1	
125259	1	1	1	1	1	1	1	1	1	1	1	1	1	
125260	1	1	1	1	1	1	1	1	1	1	1	1	1	
125261	1	1	1	1	1	1	1	1	1	1	1	1	1	

Specification Number Index

GROUP TITLE & NUMBER	<i>Air Intake</i>	<i>Fuel System</i>	<i>Cooling System</i>	<i>Engine</i>	<i>Nameplate and Decals</i>	<i>Skid and Plant Mounting</i>	<i>Exhaust</i>	<i>Generator and Mounting</i>	<i>Controller and Mounting</i>	<i>Housing and Mounting</i>	<i>Literature</i>				
GROUP NO.	101	103	104	105	107	109	116	201	301	501	701				
SPEC NO.	VARIATION NUMBER														
125237	4	5	4	4	9	4	4	14	20	-	3				
125238	4	5	4	4	9	4	4	13	19	-	3				
125239	4	5	4	4	9	4	4	15	19	5	3				
125240	4	5	4	4	9	4	4	15	19	-	3				
125241	4	5	4	4	10	4	4	16	20	5	3				
125242	4	5	4	4	10	4	4	16	20	-	3				
125243	4	5	4	4	9	4	4	13	22	-	3				
125244	4	5	4	4	9	4	4	14	23	-	3				
125245	4	5	4	4	9	4	4	15	21	-	3				
125246	4	5	4	4	9	4	4	16	24	-	3				
125247	4	6	4	4	11	4	4	14	20	-	3				
125248	4	6	4	4	12	4	4	16	20	5	3				
125249	4	6	4	4	12	4	4	16	20	-	3				
125250	4	6	4	4	11	4	4	14	23	-	3				
125251	4	6	4	4	12	4	4	16	24	-	3				
125252	5	7	5	5	13	5	5	17	26	-	3				
125253	5	7	5	5	13	5	5	18	26	7	3				
125254	5	7	5	5	13	5	5	18	26	-	3				
125255	5	7	5	5	13	5	5	17	29	-	3				
125256	5	7	5	5	13	5	5	18	30	-	3				
125257	5	7	5	5	13	5	5	19	25	-	3				
125258	5	7	5	5	13	5	5	19	25	7	3				
125259	5	7	5	5	13	5	5	19	25	-	3				
125260	5	7	5	5	13	5	5	19	28	-	3				
125261	5	7	5	5	13	5	5	19	27	-	3				

Group B1: Cylinder Head Cover

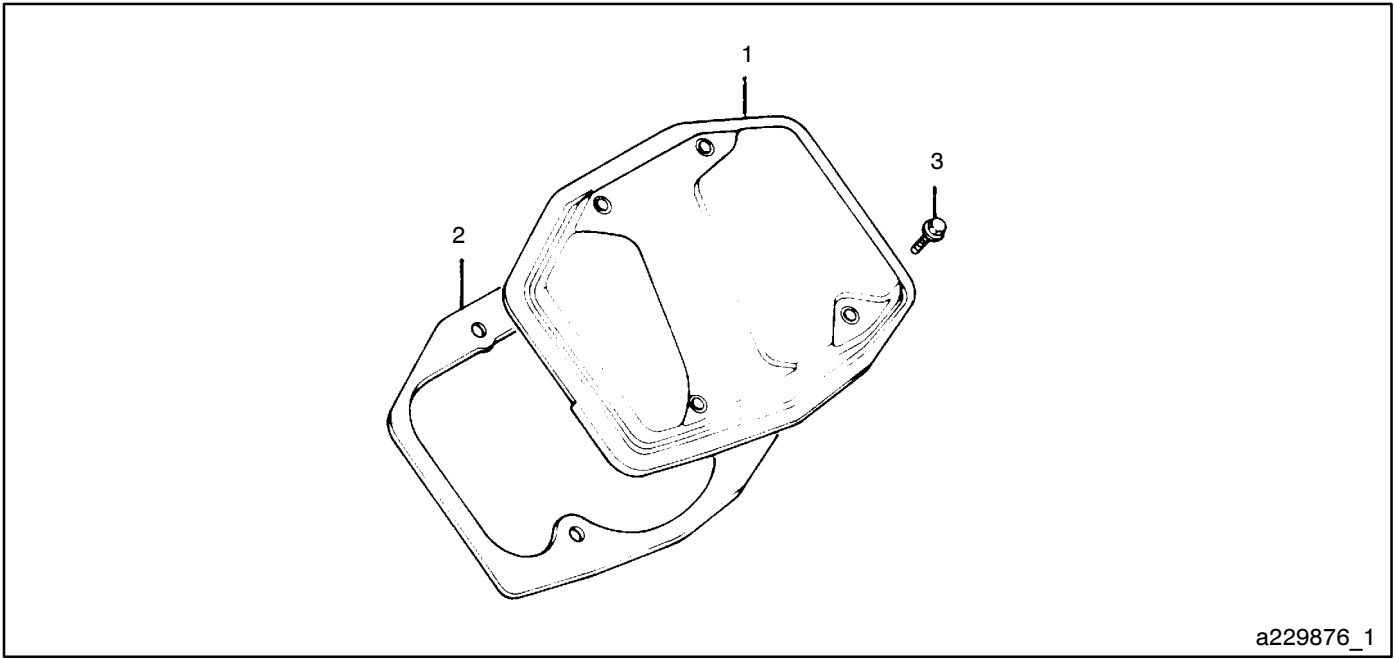

a229876_1

Item	Part Number	Description	Qty	
			Variation	
			1	
1	267852	Cover, Cylinder Head	1	
2	267708	Packing, Head Cover	1	
3	267754	Bolt, Flange, M6 x 20	4	

a229876_1

Group B2: Cylinder Head

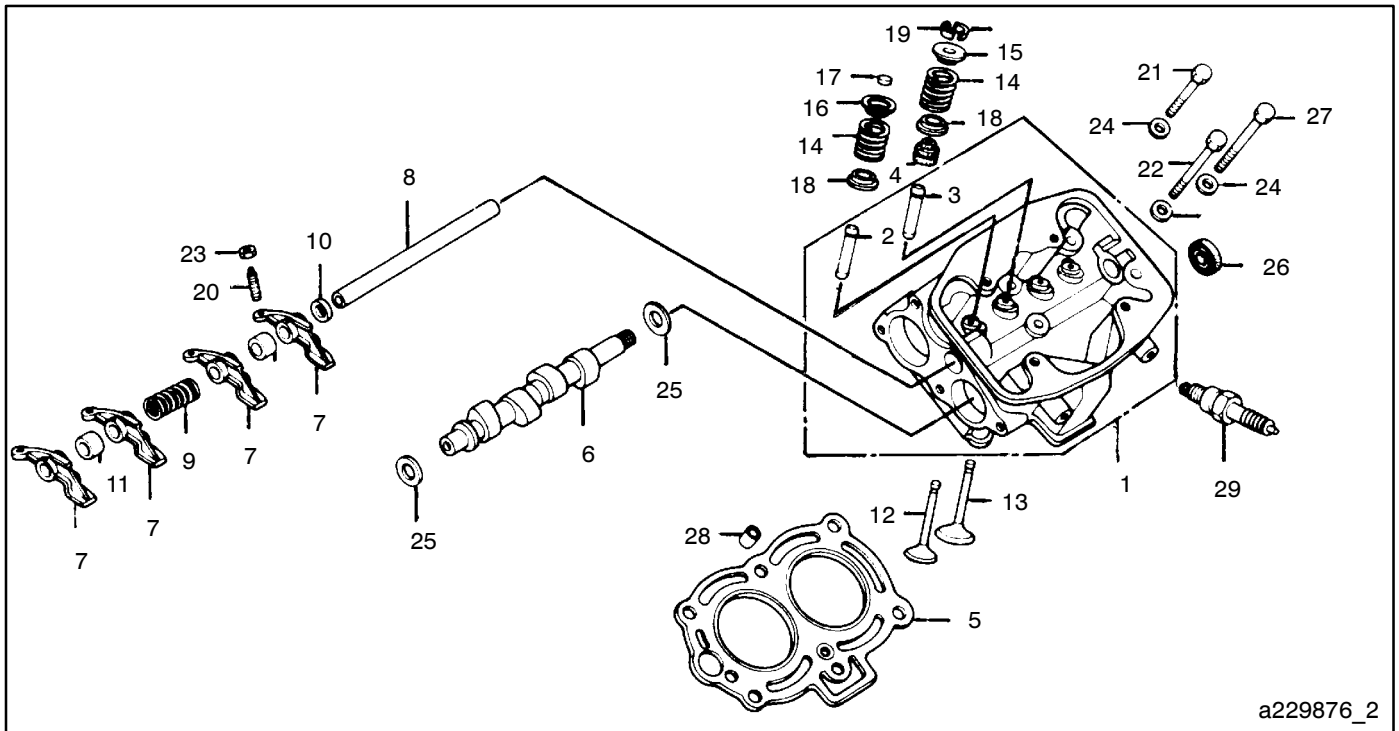

a229876_2

Item	Part Number	Description	Qty	
			1	Variation
1	267857	Cylinder Head	1	
2	267856	Guide, Exhaust Valve	2	
3	267837	Guide, Intake Valve	2	
4	267785	Seal, Valve Stem	4	
5	267710	Gasket, Cylinder Head	1	
6	267870	Camshaft	1	
7	267803	Arm, Valve Rocker	4	
8	267766	Shaft, Valve Rocker Arm	1	
9	267767	Spring, Valve Rocker Arm	1	
10	267768	Collar A, Valve Rocker Arm	1	
11	267769	Collar B, Valve Rocker Arm	2	
12	267711	Valve, Inlet	2	
13	267712	Valve, Exhaust	2	
14	267748	Spring, Valve	4	
15	267789	Retainer, Valve Spring	2	
16	267762	Retainer, Valve Spring	2	
17	267770	Rotator, Valve	2	
18	267749	Seat, Valve Spring	4	
19	267734	Cotter, Valve	4	
20	267752	Screw, Tappet Adjusting	4	
21	267753	Bolt, Head, M8 x 70	3	
22	267781	Bolt, Hex., M8 x 55	2	
23	267728	Nut, Tappet Adjusting	4	
24	267732	Washer, Head, 8mm	6	
25	267735	Washer, Thrust, 16mm	2	
26	267751	Oil Seal, M16 x 28 x 8	1	
27	267822	Bolt, Hex., M8 x 100	1	
28	267729	Pin, Dowel, M10 x 16	2	
29	267713	Plug, Spark (BPR4HS NGK)	2	

a229876_2

Group B4: Cylinder Barrel

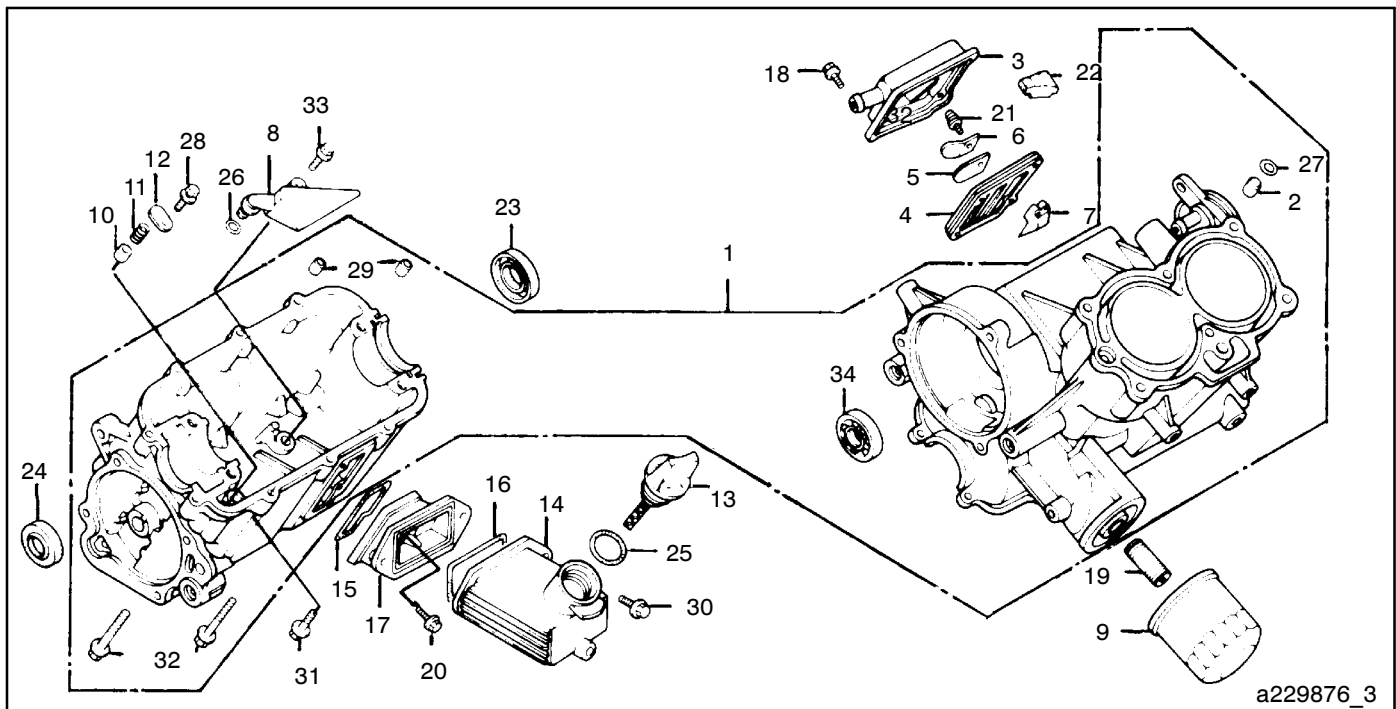

a229876_3

Item	Part Number	Description	Qty	
			1	Variation
1	267883	Barrel Assy., Cylinder	1	
2	267797	Orifice, Oil Control	1	
3	267884	Cover, Breather	1	
4	267839	Plate, Breather With Gaskets	1	
5	267866	Plate, Valve	1	
6	267867	Stopper, Valve	1	
7	267872	Guard, Breather	1	
8	267887	Filter, Oil Internal	1	
9	267714	Filter, Oil	1	
10	267821	Valve, Check	1	
11	267771	Spring, Check Valve	1	
12	267807	Plate, Check Valve	1	
13	267715	Cap, Oil Filler	1	
14	267888	Reservoir, Oil	1	
15	267889	O-Ring, Oil Joint	1	
16	267890	O-Ring, Oil Reservoir	1	
17	267891	Joint, Oil Reservoir	1	
18	239873	Bolt, Flange, M6 x 23	4	
19	267773	Holder, Oil Filter	1	
20	267835	Bolt, Flange, M6 x 23	2	
21	267774	Screw, M5 x 8	1	
22	267921	Rubber, Cylinder Barrel	1	
23	267818	Oil Seal, M33 x 48 x 7	1	
24	267814	Oil Seal, M30 x 44 x 7	1	
25	239842	O-Ring, M26 x 2.7	1	
26	267858	O-Ring, M11.8 x 2.4	1	
27	267796	O-Ring, M10.8 x 2.4	2	
28	267787	Bolt-Washer, M6 x 12	1	
29	267729	Pin, Dowel, M10 x 16	4	
30	267741	Bolt, Flange, M6 x 25	2	
31	267740	Bolt, Flange, M6 x 28	1	
32	267764	Bolt, Flange, M8 x 55	1	
33	267862	Bolt, Flange, M6 x 18	1	
34	239846	Bearing, Radial Ball, 6202	1	

a229876_3

Group B6: Thermostat

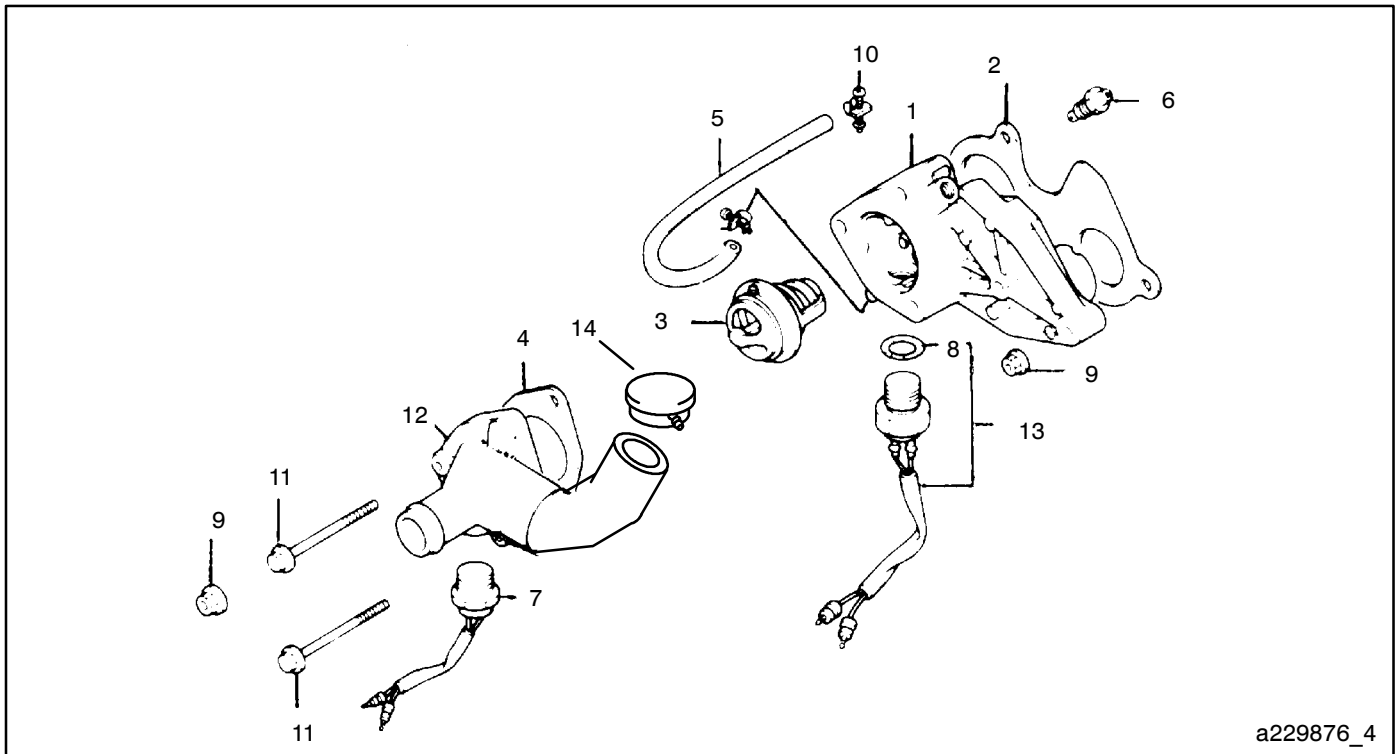

a229876_4

Item	Part Number	Description	Qty	
			1	Variation
1	267859	Case, Thermostat	1	
2	267809	Packing, Governor Case	1	
3	267717	Thermostat Assembly	1	
4	267718	Packing, Thermostat Cover	1	
5	267810	Hose, Water Bypass	1	
6	267794	Bolt, Breathing Water	1	
7	267922	Switch, Thermostat Solenoid (Shutdown)	1	
8	267757	O-Ring, M15.5 x 1.4	1	
9	267776	Nut, Flange, 6mm	1	
10	267784	Clip, Tube (D12.5)	1	
11	267775	Bolt, Flange, M6 x 65	1	
12	229995	Cover, Thermostat	1	
	344056	Gasket, Thermostat Housing	1	
13	267920	Switch, Engine Thermostat (Choke)	1	
14	229958	Cap, Pressure	1	

a229876_4

Group B7: Oil Pump

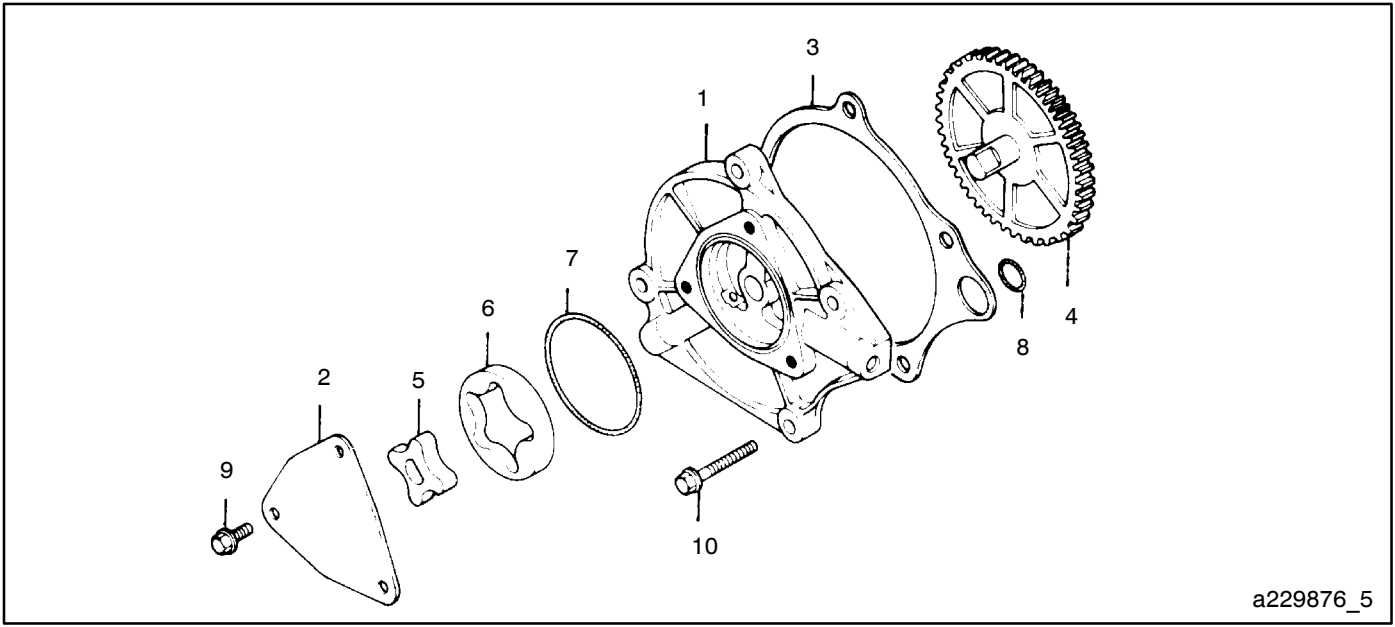

a229876_5

Item	Part Number	Description	Qty	
			Variation	
1	267885	Body, Oil Pump	1	
2	267804	Cover, Oil Pump	1	
3	267886	Packing, Oil Pump	1	
4	267876	Gear Assembly, Oil Pump	1	
5	267805	Rotor, Inner	1	
6	267806	Rotor, Outer	1	
7	267815	O-Ring, Pump Cover	1	
8	267796	O-Ring, M10.8 x 2.4	1	
9	267738	Bolt, Flange, M6 x 12	3	
10	267741	Bolt, Flange, M6 x 25	4	

a229876_5

Notes

Group B8: Crankshaft & Piston

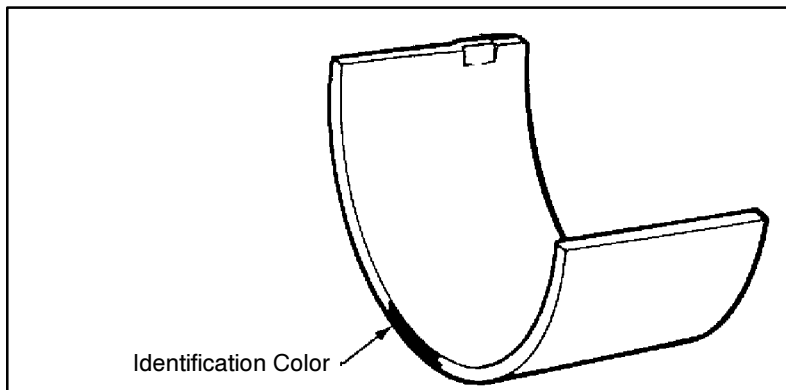
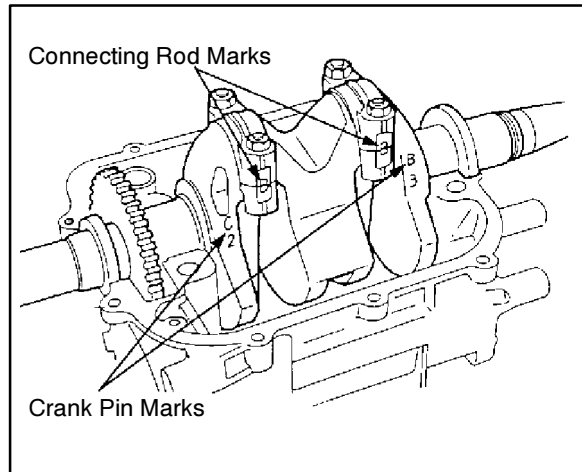
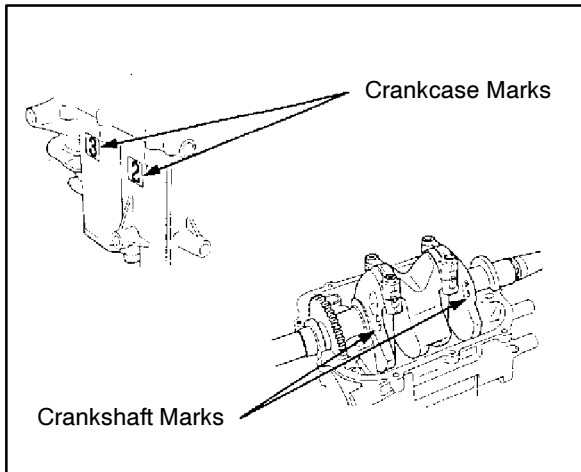
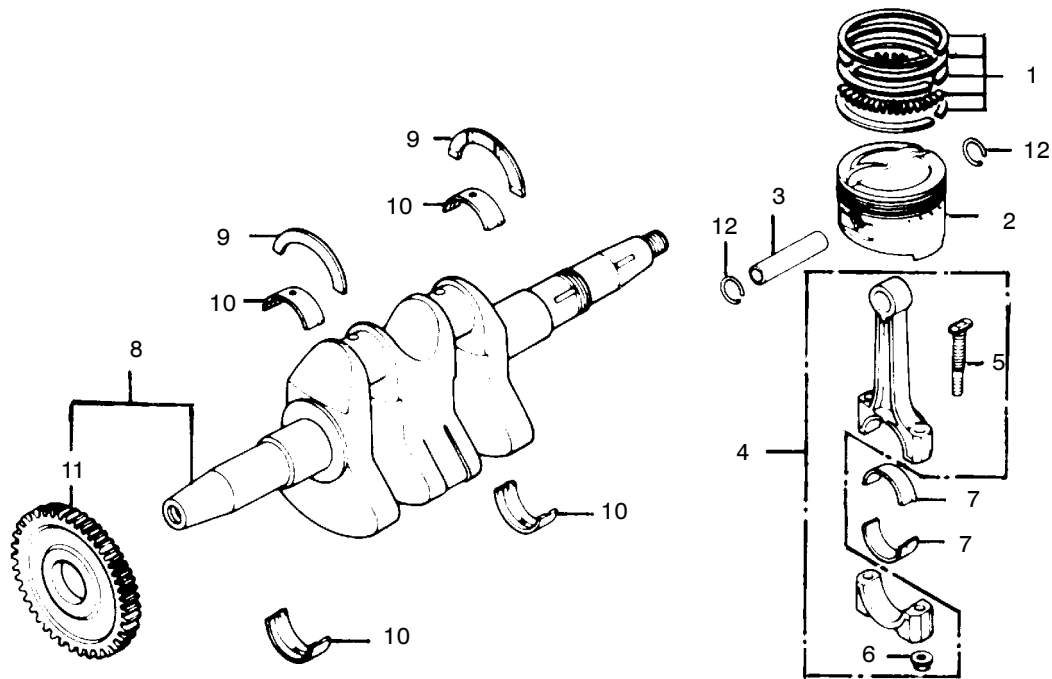

a229876_6

Group B8: Crankshaft & Piston

Item	Part Number	Description	Qty	
			1	Variation
1	267719	Ring Set, Piston (Std.)	2	
1	267828	Ring Set, Piston (0.25)	2	
1	267829	Ring Set, Piston (0.50)	2	
2	267720	Piston (Std.)	2	
2	267819	Piston (0.25)	2	
2	267820	Piston (0.50)	2	
3	267765	Pin, Piston	2	
4	267721	Rod Assembly, Connecting	2	
5	267782	Bolt, Connecting Rod	4	
6	267783	Nut, Connecting Rod	4	
7	See chart	Bearing, Connecting Rod	4	
8	267873	Crankshaft	1	
9	267830	Bearing, Crankshaft Thrust	2	
10	See chart	Bearing, Crankshaft	4	
11	267875	Gear, Oil Pump Drive	1	
12	267756	Clip, Piston Pin, 14mm	4	

a229876_6

Connecting Rod Bearing Selection Table

Select replacement bearings according to the size codes marked on the crankshaft and connecting rod.

		Connection Rod I.D. 35mm		
		Mark A	Mark B	Mark C
Crank Pin O.D. 32mm		0 + 0.008	+ 0.008 + 0.016	+ 0.016 + 0.024
Mark A	+ 0.014 + 0.006	267747 (Red)	267746 (Yellow)	267745 (Green)
Mark B	+ 0.006 - 0.002	267746 (Yellow)	267745 (Green)	267744 (Brown)
Mark C	- 0.002 - 0.010	267745 (Green)	267744 (Brown)	267743 (Black)

Crankshaft Bearing Selection Table

Measure inner diameter (I.D.) of the crankcase journal bearing bore. Measure the outer diameter (O.D.) of the crankshaft journal. Select replacement bearings to obtain correct journal oil clearance. Standard oil clearance is 0.02-0.04mm (0.001-0.002 in.).

		Crankshaft O.D. 33mm		
		Mark 1	Mark 2	Mark 3
Crankcase I.D. 36mm		+ 0.018 + 0.012	+ 0.012 + 0.006	+ 0.006 0
Mark 1	0 + 0.006	267802 (Red)	267801 (Yellow)	267800 (Green)
Mark 2	+ 0.006 + 0.011	267801 (Yellow)	267800 (Green)	267799 (Brown)
Mark 3	+ 0.016 + 0.016	267800 (Green)	267799 (Brown)	267798 (Black)

Group B10: Timing Belt Cover & Water Pump

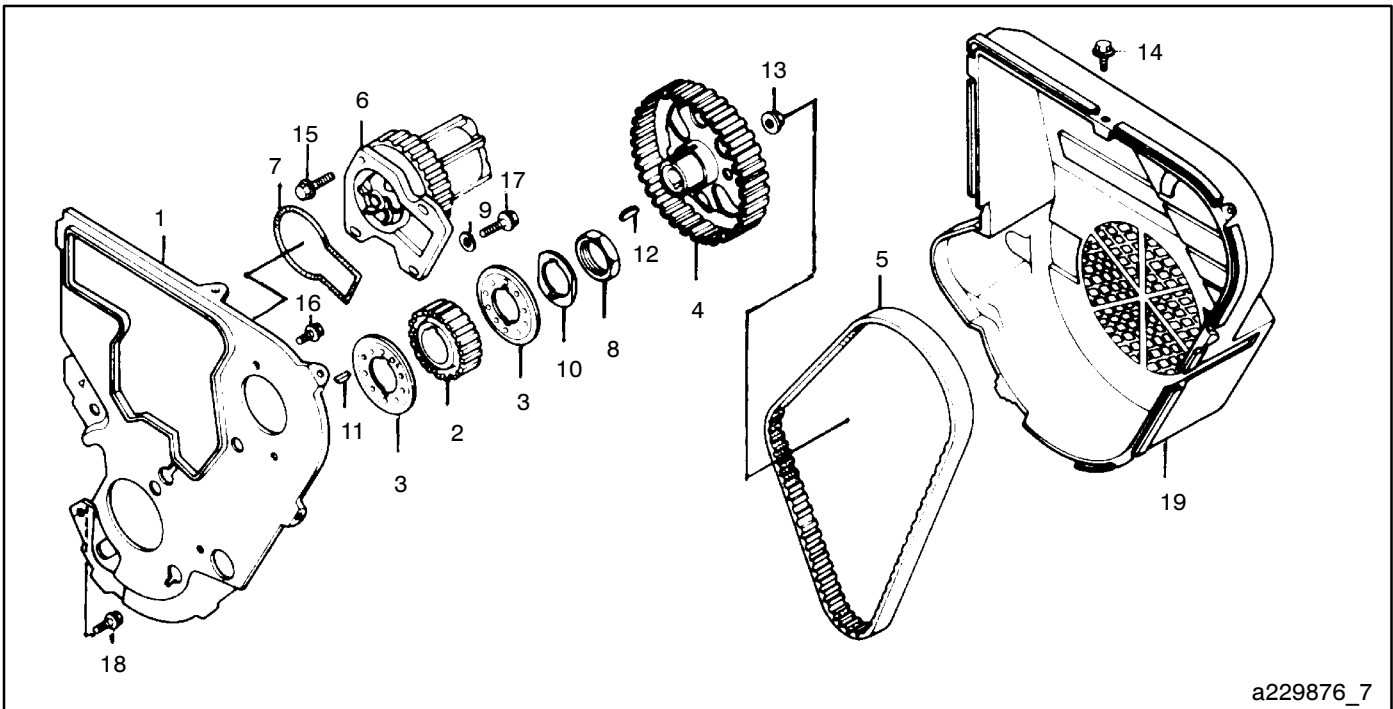

a229876_7

Item	Part Number	Description	Qty	
			1	Variation
1	267881	Cover B, Timing Belt	1	
2	267816	Pulley, Timing	1	
3	267817	Flange, Timing Pulley	2	
4	267871	Pulley, Camshaft	1	
5	267722	Belt, Timing	1	
6	267841	Pump, Water	1	
7	267795	O-Ring, Water Pump	1	
8	267811	Nut, Lock, 30mm	1	
9	267812	Washer, Plain, M6.5 x 15	3	
10	267813	Washer, Lock 30mm	1	
11	239865	Key, Special w/Woodruff, M25 x 18	1	
12	267750	Key, Cam Pulley	1	
13	267777	Nut, Flange 10mm	1	
14	267758	Bolt, Flange, M6 x 10	5	
15	267739	Bolt, Flange, M6 x 22	1	
16	267790	Bolt, Flange, M6 x 12	3	
17	267788	Bolt, Flange, M6 x 22	3	
18	267855	Bolt, Flange, M6 x 10	2	
19	267405	Cover, Timing Belt	2	

a229876_7

Group C3: Flywheel

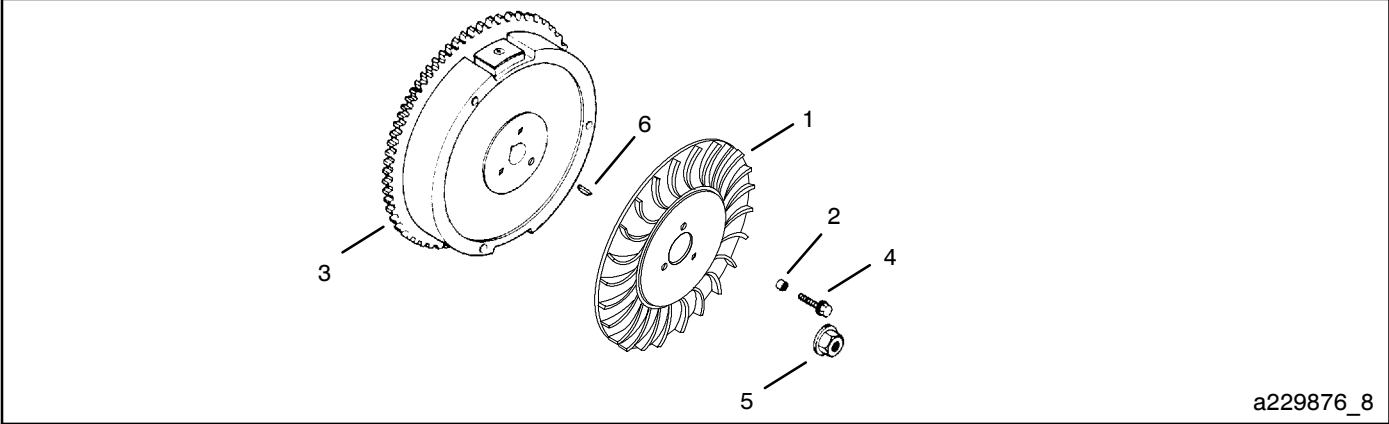

a229876_8

Item	Part Number	Description	Qty	
			1	Variation
1	267364	Fan, Cooling	1	
2	267778	Collar, Fan	3	
3	267910	Flywheel	1	
4	267792	Bolt, Flange, M6 x 16	3	
5	239864	Nut, Special, 16mm	1	
6	239865	Key, Special Woodruff, M25 x 18	1	

a229876_8

Group C4: Ignition Coil

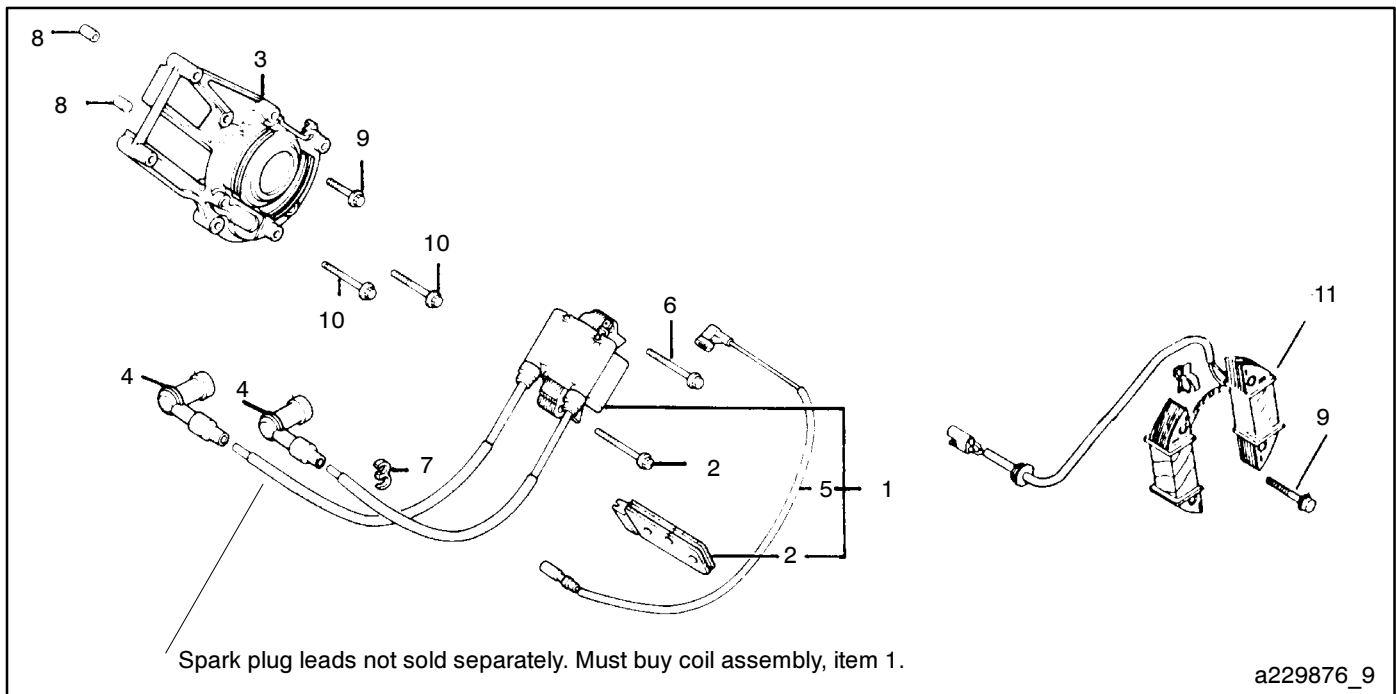

Item	Part Number	Description	Qty	
			Variation	
1	267725	Coil Assembly, Ignition	1	
2	267843	Grommet, High Tension Cord	1	
3	267846	Stay, Ignition System	1	
4	267847	Cap Assembly, Noise Suppressor	2	
5	267844	Cord, Engine Stop	1	
6	239874	Bolt, Flange, M6 x 28	2	
7	267848	Clip, High Tension Cord	1	
8	267731	Pin A, Dowel, M8 x 10	2	
9	267739	Bolt, Flange, M6 x 22	1	
10	267740	Bolt, Flange, M6 x 28	2	
11	267976	Twin Coil, Charger	1	

a229876_9

Group C5: Starter Motor

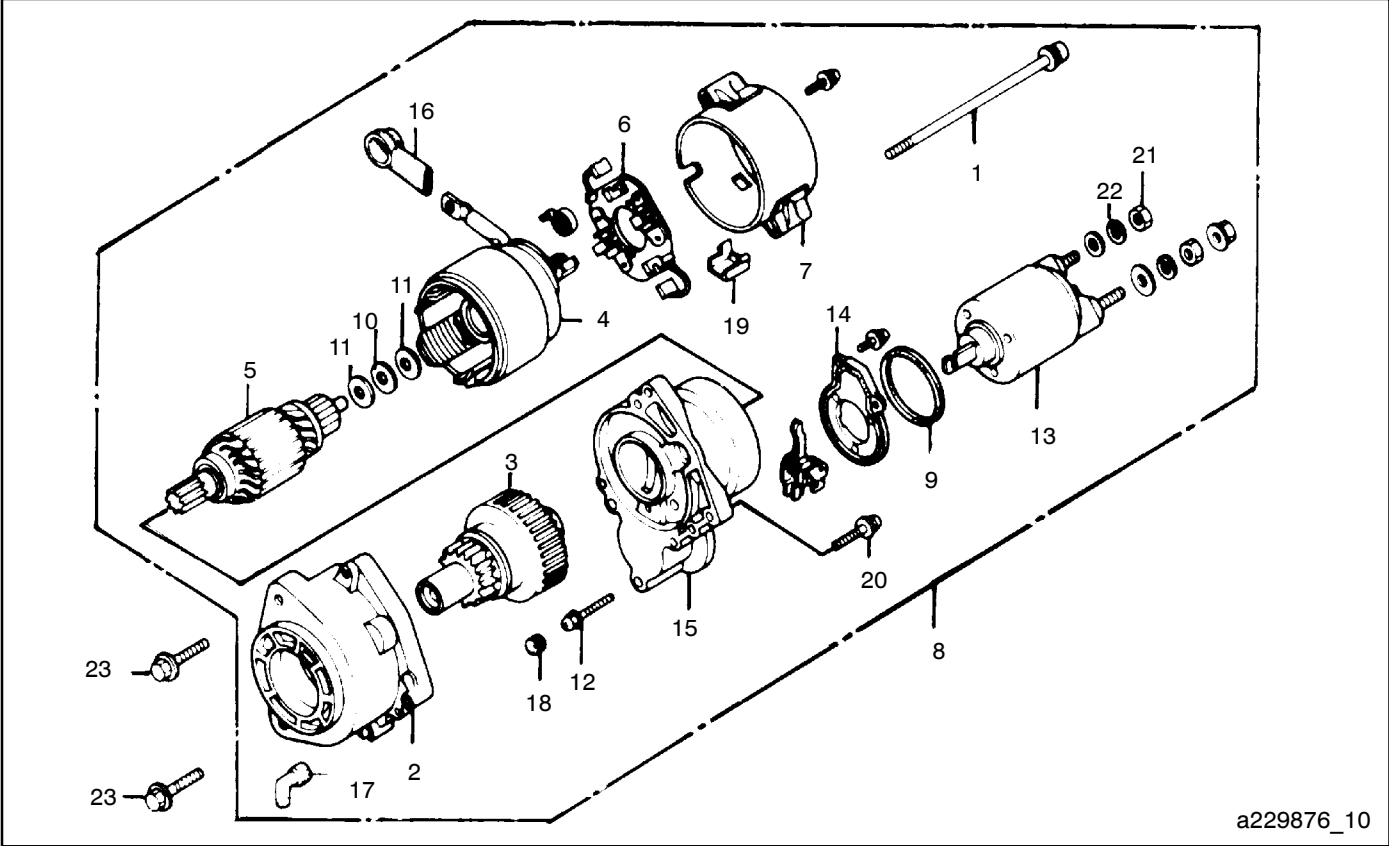

Item	Part Number	Description	Qty	
			1	Variation
1	267832	Bolt, Through	2	
2	267911	Cover, Gear	1	
3	267912	Gear Assembly	1	
4	267913	Yoke Assembly	1	
5	267823	Armature	1	
6	267914	Stay Assy., Brush (Mitsuba)	1	
7	267915	Bracket Assy., Rear	1	
8	267726	Motor Assy., Starter	1	
9	267824	Ring, Square	1	
10	267833	Washer, Thrust, M1.2	1	
11	267834	Washer, Thrust, M0.2	2	
12	267825	Screw w/Washer, M4 x 28	3	
13	267727	Switch Assy.	1	
14	267916	Plate, Front	1	
15	267917	Front Assy.	1	
16	267838	Cover, Terminal	1	
17	267918	Tube, Labyrinth	1	
18	267831	Bush, Rubber	3	
19	267919	Cover, Drain	1	
20	267826	Screw-Washer, M6 x 30	3	
21	267772	Nut, Hex, 8mm	1	
22	267742	Washer, Spring, 8mm	1	
23	267863	Bolt, Flange, M8 x 20	2	

a229876_10

Group C6: Governor Arm & Balancer Weight

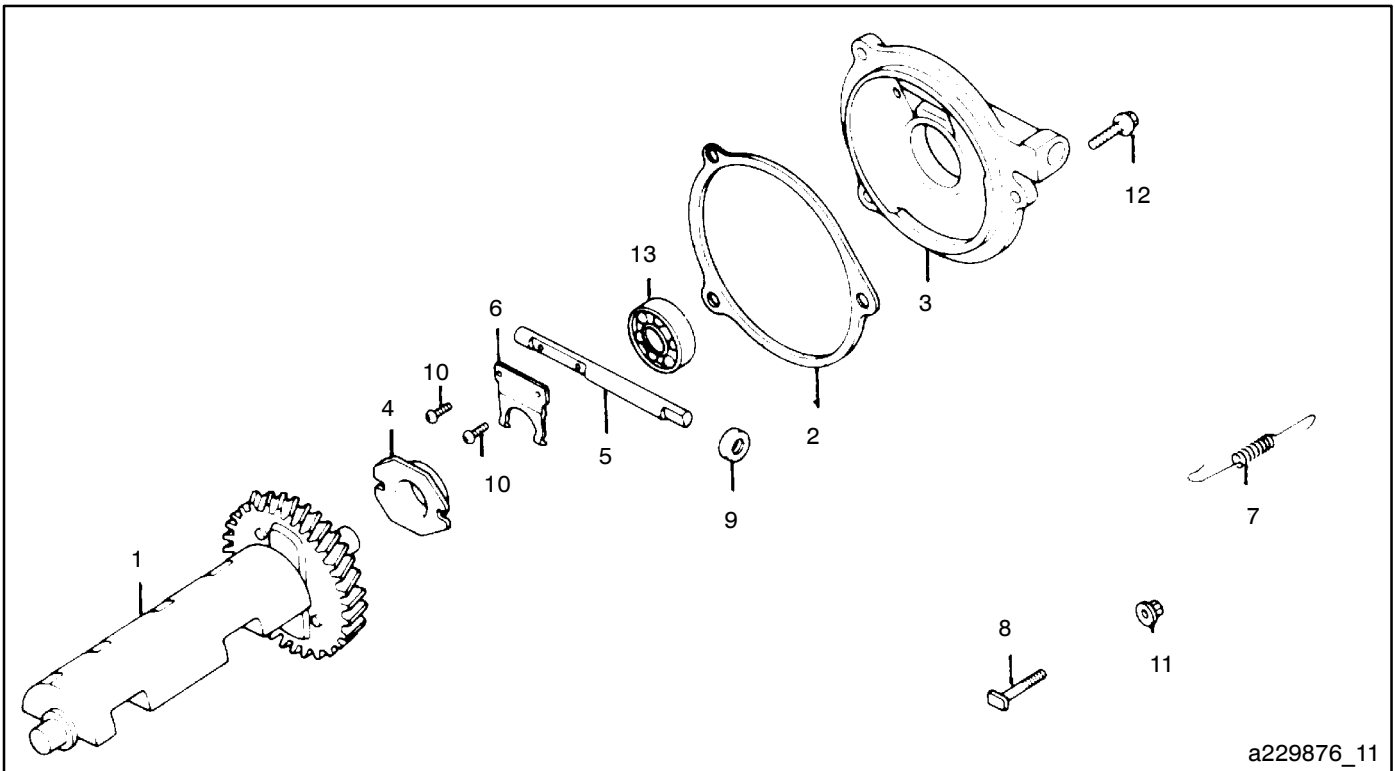

a229876_11

Item	Part Number	Description	Qty	
			1	Variation
1	267874	Weight, Balancer	1	
2	267900	Packing, Governor Cover	1	
3	267877	Cover, Governor	1	
4	267924	Slider, Governor	1	
5	267851	Shaft, Governor Arm	1	
6	267878	Fork, Governor	1	
7	246481	Spring, Governor	1	
8	239946	Bolt, Governor Arm	1	
9	239855	Oil Seal, M8 x 14 x 5	1	
10	267761	Screw, Pan, M3 x 8	2	
11	229948	Nut, Flange, 6mm	1	
12	267741	Bolt, Flange, M6 x 25	3	
13	239846	Bearing, Radial Ball, 6202	1	

a229876_11

Group C7: Engine Mount Stay

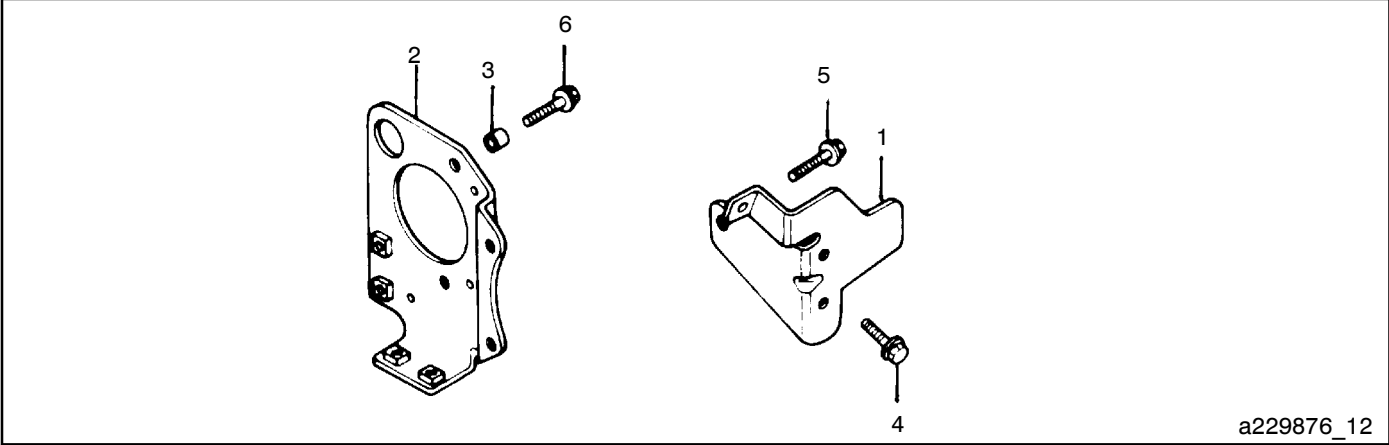

a229876_12

Item	Part Number	Description	Qty	
			1	Variation
1	267879	Stay, Right Engine Mount	1	
2	267880	Stay, Left Engine Mount	1	
3	267849	Pin, Dowel, M10 x 12	2	
4	267763	Bolt, Flange, M8 x 20	1	
5	267868	Bolt, Flange, M8 x 25	1	
6	267864	Bolt, Flange, M8 x 28	2	

a229876_12

Group C8: Front Housing

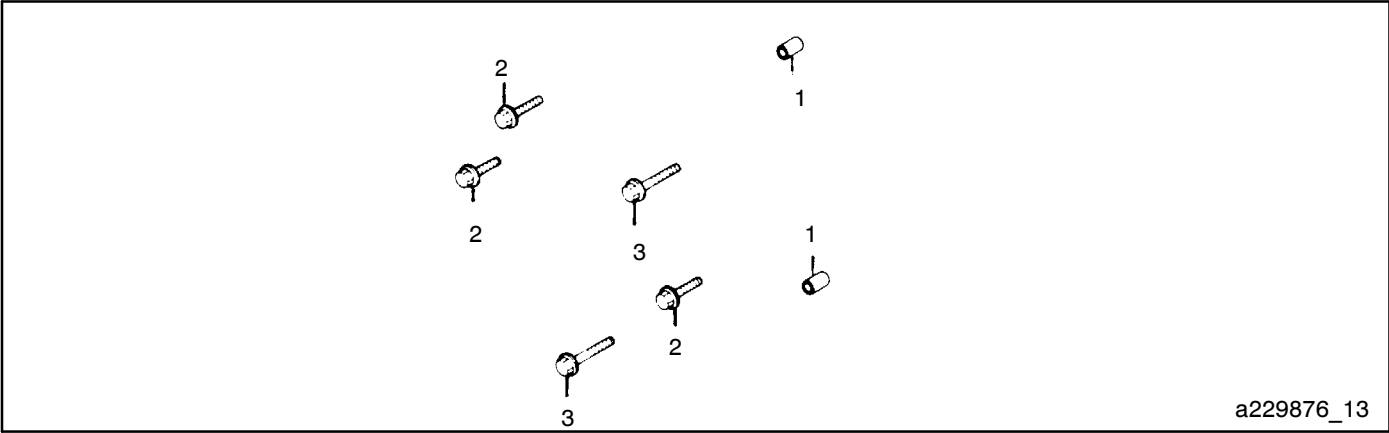

a229876_13

Item	Part Number	Description	Qty	
			1	Variation
1	267730	Pin A. Dowel, M10 x 14	2	
2	267779	Bolt, Flange, M8 x 32	3	
3	267755	Bolt, Flange, M8 x 40	2	

a229876_13

Group 101: Air Intake

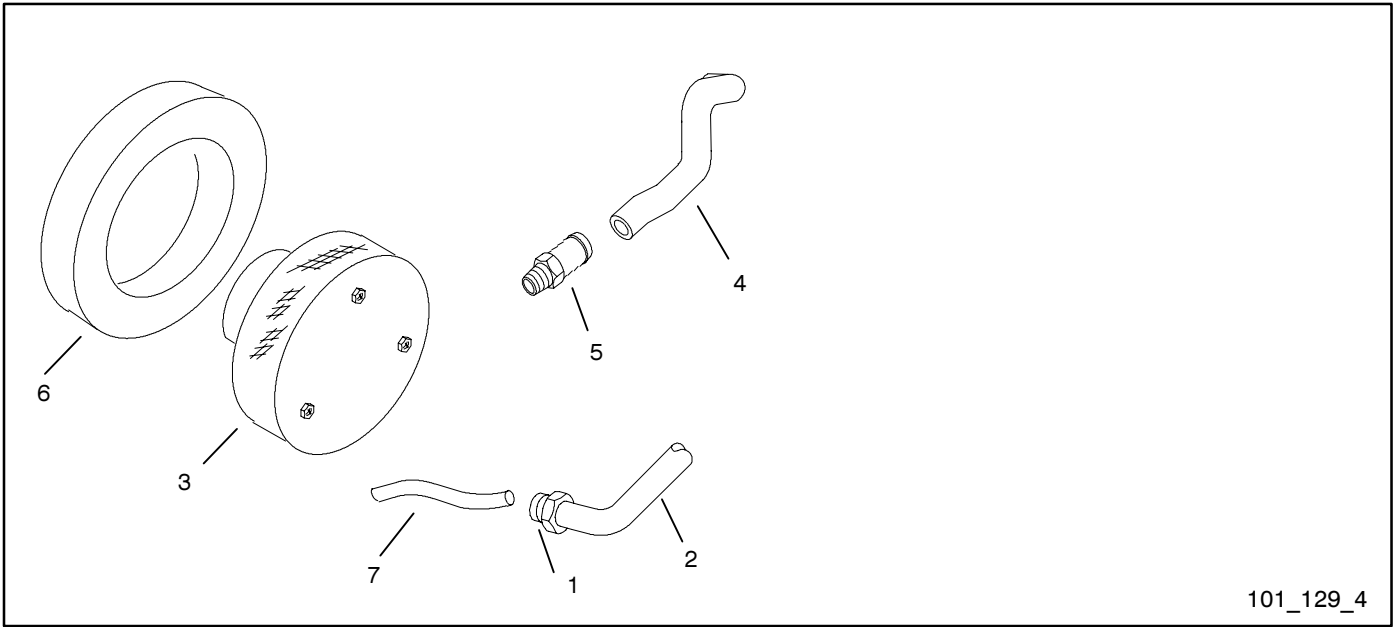

101_129_4

Item	Part Number	Description	Qty	
			Variation	
			4	5
1	X-258-8	Connector, Compression	1	1
2	246053	Hose, Vacuum	1	1
3	249900	Arrestor, Flame	1	1
4	344507	Hose, Breather	1	1
5	344508	Connector, Hose	1	1
6	344632	Foam, Acoustic	1	1
7	344633	Line, Vent	1	1
101_129_4				

Notes

Group 103: Fuel System

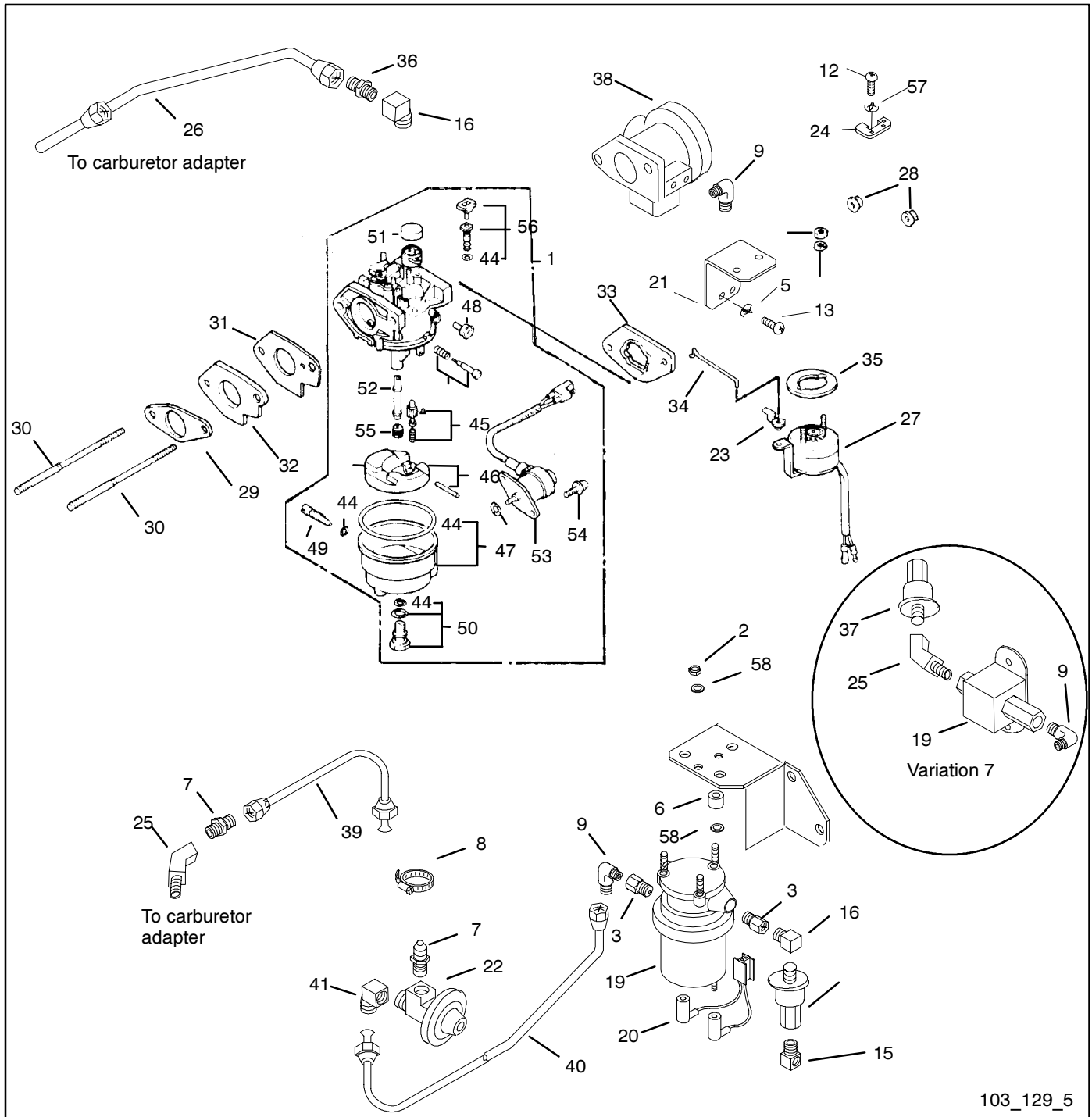

103_129_5

Item	Part Number	Description	Qty		
			Variation		
			5	6	7
1	344489	Carburetor Kit (includes items 29, 31, and 44-56)	1	1	1
2	X-101-25	Nut, Hex Elastic Stop	3	3	
3	X-202-27	Bushing, Reducer, 1/8	2	2	
4	X-22-12	Washer, Lock, 1/4 Int./Ext. Tooth	2	2	2
5	X-22-7	Washer, Lock, #8 Int. Tooth	3	3	3
6	X-284-29	Grommet	3	3	
7	X-296-5	Connector, Half-Union	2	2	1

103_129_5

Group 103: Fuel System

Item	Part Number	Description	Qty		
			Variation		
			5	6	7
8	X-426-8	Clamp, Hose, 1-15/16	2	2	
9	X-447-13	Elbow	2	2	2
10	X-468-3	Tie, Cable Nylon (not shown)	1	1	1
11	X-468-4	Tie, Cable (not shown)	2	2	
12	X-49-2	Screw, r.h.m., 6-32 x .375	1	1	1
13	X-51-15	Screw, r.h.m., 8-32	3	3	
14	X-519-10	Plug, Cap, 1/4 inch (not shown)	1	1	1
15	X-555-1	Elbow, Street, 1/4 x 1/4	1	1	
16	X-555-2	Elbow, Street, 1/8 x 1/8	2	2	1
17	X-6074-3	Sleeve, Fire, 2.25" ID. (not shown)	1	1	
18	X-72-4	Nut, Hex 8-32 Zinc Plated (not shown)	1	1	1
19	229051	Pump, Fuel	1	1	
19	278490	Pump, Fuel			1
20	229168	Lead Assembly	1	1	
21	229933	Bracket, Choke	1	1	1
22	239683	Regulator, Pressure	1	1	
23	239967	Joint, Rod	1	1	1
24	267420	Lever, Throttle	1	1	1
25	267428	Elbow, 45° Street	1	1	2
26	267483	Line, Fuel Recovery	1	1	1
27	267724	Solenoid Assembly	1	1	1
28	267776	Nut, Flange	2	2	2
29	267840-S	Gasket, Carburetor	1	1	1
30	267845	Bolt, Stud	2	2	2
31	267850-S	Packing, Carburetor	1	1	1
32	267853	Insulator, Carburetor	1	1	1
33	267865	Spacer, Carburetor	1	1	1
34	267898	Rod, Solenoid	1	1	1
35	267899	Spacer, Solenoid	1	1	1
36	267932	Connector, Half-Union	1	1	1
37	267987	Filter, Fuel	1	1	1
38	344293	Adapter, Carburetor	1	1	1
39	344311	Line, Fuel	1	1	
40	344312	Line, Fuel	1	1	
40	359166	Line, Fuel			1
41	344370	Fitting, Female	1	1	
42	344628	Bracket, Fuel Pump	1	1	
43	344884	Bracket, Regulator (not shown)	1	1	
44	267892	Gasket Set	1	1	1
45	239950	Valve Set, Float (includes needle and seat)	1	1	1
46	239951	Float Set	1	1	1
47	267893	Chamber Set, Float	1	1	1
48	239953	Set Screw, Pilot	1		
48	344560	Set Screw, Pilot		1	1
49	267780	Set Screw, Drain	1	1	1
50	267894	Set Screw	1	1	1
51	239958	Dust Cap, Choke	1	1	1
52	267895	Nozzle, Main	1	1	1
53	267896	Solenoid, Valve	1	1	1
54	267760	Screw w/Washer, M5 x 12	2	2	2
55	344211	Jet, Main #105	1	1	1
56	344212	Jet, Pilot #40	1	1	1
	344163	Pilot and Main Jet Kit (includes items 55 and 56)	1	1	1
57	#	Washer, #6	1	1	1
58	#	Washer, 1/4	3	3	3

103_129_5

Group 104: Cooling System

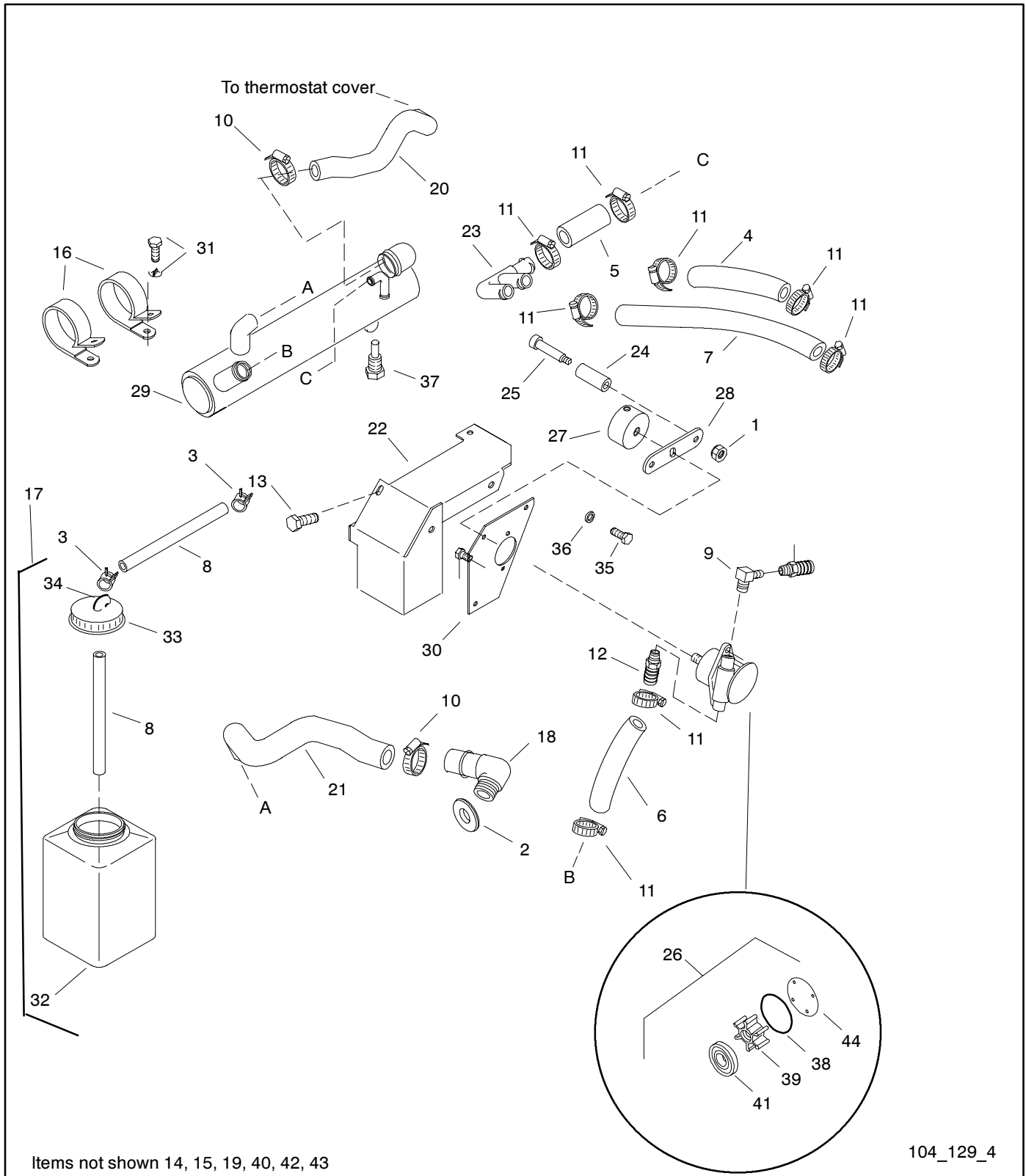

Items not shown 14, 15, 19, 40, 42, 43

104_129_4

Group 104: Cooling System

Item	Part Number	Description	Qty	
			4	5
1	X-101-16	Nut, Elastic Stop 5/16	2	2
2	X-25-125	Washer, Plain	1	1
3	X-309-16	Clamp, Spring Hose	2	2
4	X-312-10	Hose, 5/8 x 7.62"	1	1
5	X-312-23	Hose, 5/8 x 8.62"	1	1
6	X-312-3	Hose, 5/8 x 2.5"	1	1
7	X-312-42	Hose, 5/8 x 5"	1	1
8	X-386-95	Line, Fuel	1	1
9	X-391-27	Connector, Hose Elbow	1	1
10	X-426-15	Clamp, Hose	4	4
11	X-426-3	Clamp, Hose 1/2 x 1-13/32	8	8
12	X-582-19	Connector, Hose	1	1
13	X-6049-2	Screw, H.C. M6 x 1	5	5
14	X-6050-3	Screw, Hex Head Cap (not shown)	2	2
15	X-67-115	Screw, Self Tapping (not shown)	1	1
16	X-672-18	Clamp, Insulated	2	2
17	229878	Bottle, Overflow (includes items 8, 32-34)	1	1
18	246474	Elbow, Water	1	1
19	246490	Bracket, Heat Exchange (not shown)	1	1
20	260071	Hose, Molded	1	1
21	260072	Hose, Molded	1	1
22	260079	Bracket, Mounting	1	1
23	260083	Elbow, Water Hose	1	1
24	267441	Pin, Drive Tube	2	2
25	267445	Screw, Shoulder Socket	2	2
26	344371	Pump, Sea Water (includes items 38-44)	1	1
27	344372	Cup, Pilot	1	1
28	344373	Drive, Water Pump	1	1
29	344595	Exchanger, Heat	1	1
30	344631	Bracket, Mounting	1	1
31	#	Hardware, 1/4-20	2	2
32	344494	Tank, Reserve	1	1
33	344495	Cap, Reserve Tank	1	1
34	344022	Joint, Reserve Tank	1	1
35	X-465-18	Screw	3	3
36	#	Washer, 1/4	3	3
37	267928	Anode, Zinc	1	1
38	344584	O-Ring	1	1
39	229826	Impeller	1	1
40	344587	Drive Shaft (not shown)	1	1
41	344043	Ball Bearing	1	1
42	344107	Plug, 3/8" Plastic	1	1
43	344585	Housing	1	1
44	344306	Cover Plate	1	1

104_129_4

Group 105: Engine

Note: See Groups B1 through C8 for item 1, engine components.

Items not shown: 17

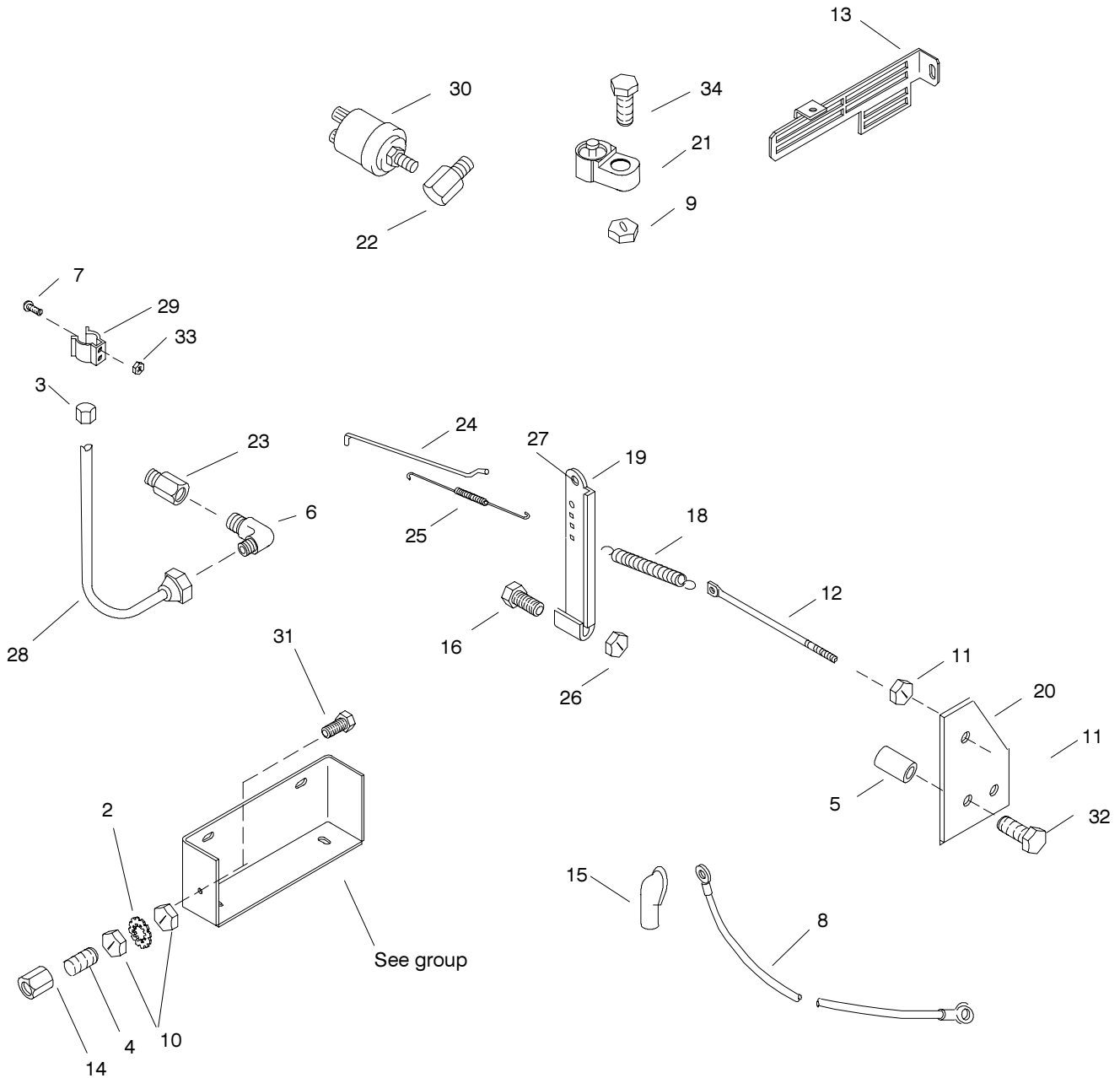

105_129_4

Group 105: Engine

Item	Part Number	Description	Qty	
			4	5
1	A-229876	Engine Assembly GX-360	1	1
2	X-22-12	Washer Lock 1/4 int./ext. tooth	2	2
3	X-268-3	Cap, Pipe	1	1
4	X-352-87	Stud	1	1
5	X-400-28	Spacer	2	2
6	X-447-1	Elbow 5/8-18 x 1/4	1	1
7	X-51-15	Screw, r.h.m., 8-32	1	1
8	X-545-27	Cable, Battery	1	1
9	X-70-3	Nut, Hex, 10-32 Zinc Plated	2	2
10	X-76-2	Nut, Hex	2	2
11	X-81-9	Nut, Hex	2	2
12	229884	Rod, Governor Adjusting	1	1
13	229932	Plate, Closure	1	1
14	233269	Insulator, Panel	1	1
15	238915	Boot	2	2
16	239946	Bolt, Governor Arm	1	1
17	246421	Screen, Starter	1	1
18	246481	Spring, Gov. Speed Adjust	1	1
19	246488	Arm, Governor	1	1
20	246492	Bracket, Governor Spring	1	1
21	249872	Switch, High Temp. Cut	2	2
22	267340	Adapter, Sender	1	1
23	267359	Adapter, Oil Drain	1	1
24	267404	Linkage, Carburetor	1	1
25	267446	Spring, Anti-Slack	1	1
26	267776	Nut, Flange	1	1
27	267869	Joint, Rod	1	1
28	267958	Hose, Oil Drain	1	1
29	267959	Clip, Hose	1	1
30	289282	Switch, Oil Pressure	1	1
31	X-465-13	Screw, Ref.	1	1
32	X-465-8	Screw, Ref.	2	2
33	#	Nut, #8-32	1	1
34	X-6238-10	Screw, Ref.	2	2

105_129_4

Group 107: Nameplate and Decals

Item	Part Number	Description	Qty				
			9	10	11	12	13
1	X-6275-2	Decal, Kohler	1	1	1	1	1
2	X-781-1	Rivet, Pop	8				
3	X-793-3	Rivet, Pop	4	8	8	8	8
4	224233	Decal, 1-800 Number	1	1	1	1	1
5	228518	Nameplate	1	1	1	1	1
6	229831	Decal, Reconnection	1	1	1	1	1
7	238162	Marker, Adhesive	1	1	1	1	1
8	239768	Tag, Hang	1	1	1	1	1
9	239796	Decal, Warning	1	1		1	1
10	249808	Decal, Warning	1	1	1	1	1
11	249809	Decal, Warning	1	1	1	1	1
12	249810	Decal, Warning	1	1	1	1	1
13	249899	Tag, Hang	1	1	1	1	1
14	267468	Decal, Coast Guard	1	1	1	1	
15	267939	Plate, Converting	1	1	1	1	
16	344282	Decal, Notice	1	1	1	1	
17	344295	Decal, Equipment Ground	1	1	1	1	
18	344588	Decal, CE	1	1	1	1	1
19	226889	Decal, Emission			1	1	1

107_129_9

Group 109: Skid and Plant Mounting

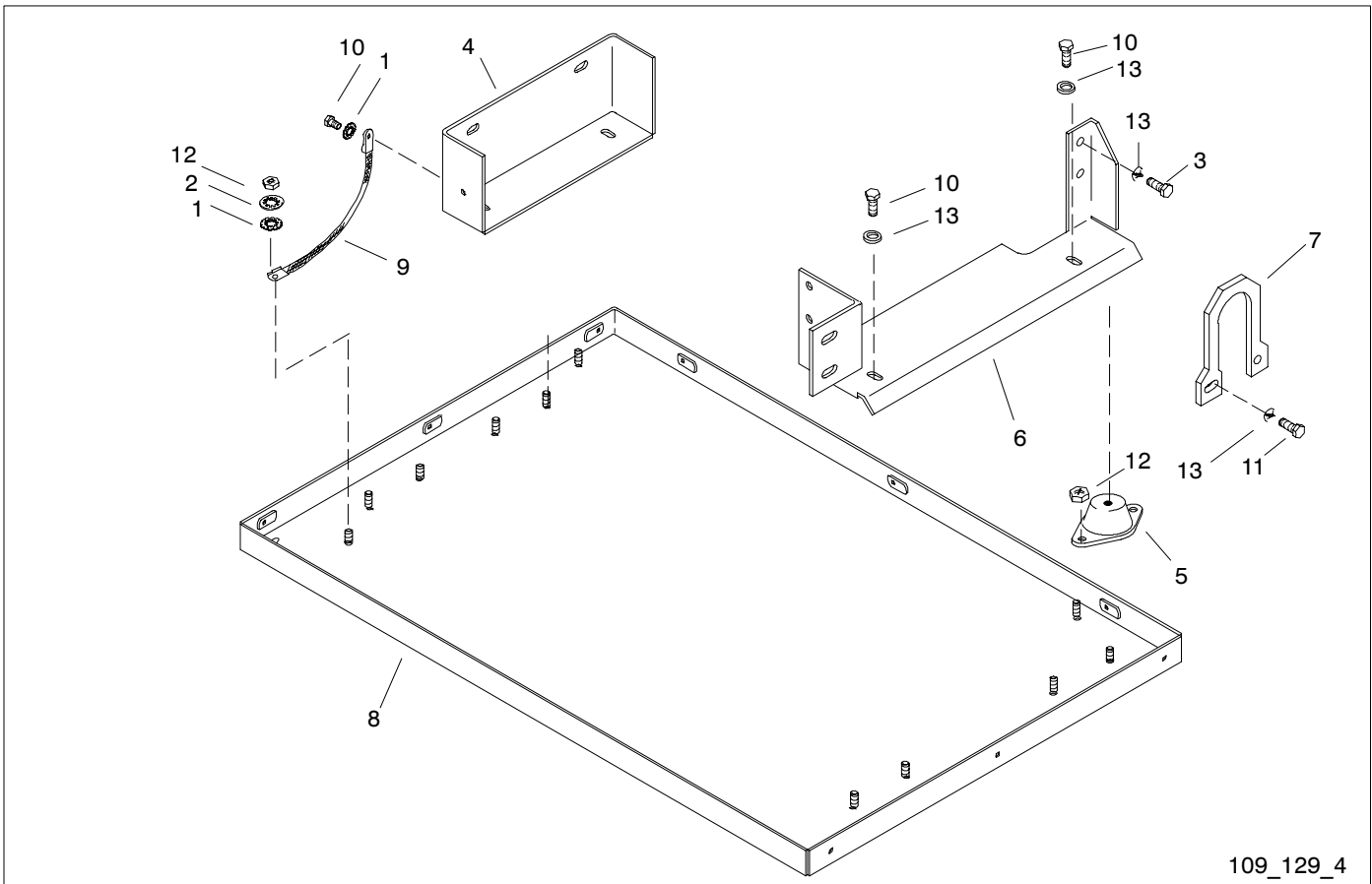

109_129_4

Item	Part Number	Description	Qty	
			4	5
1	X-22-16	Washer, Lock, 5/16 Int./ext. Tooth	2	2
2	X-22-5	Washer, Lock, 5/16 Int. Tooth	1	1
3	X-6050-3	Screw, Hex Head Cap	4	4
4	229934	Bracket, Alter. Support	1	1
5	239673	Damper, Vibro	4	4
6	246496	Bracket, Engine Mounting	1	1
7	246497	Bracket, Lifting	1	1
8	267984	Tray	1	1
9	290418	Strap, Ground	1	1
10	X-125-3	Screw, Ref.	6	6
11	X-125-30	Screw, Ref.	2	2
12	#	Nut, 5/16-18	1	1
13	#	Washer, 5/16	4	4

109_129_4

Group 116: Exhaust

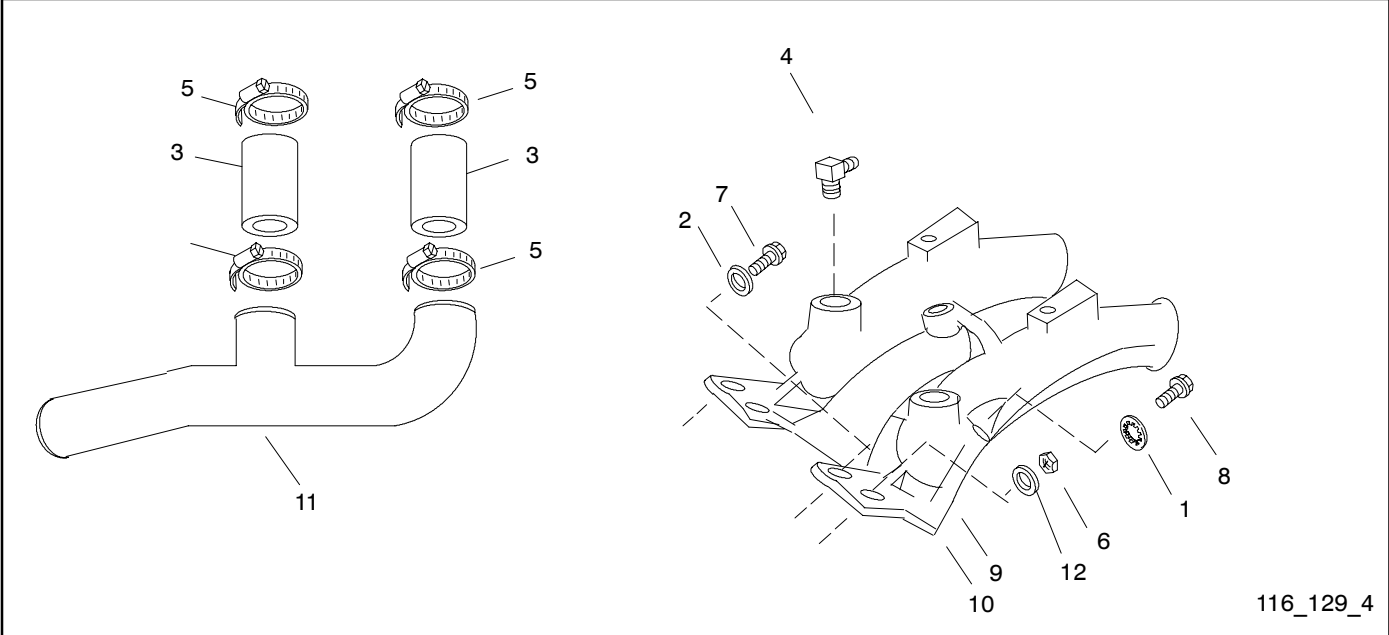

116_129_4

Item	Part Number	Description	Qty	
			4	5
1	X-22-5	Washer, Lock, 5/16 Int. Tooth	1	1
2	X-25-63	Washer, Plain	3	3
3	X-281-4	Hose, Radiator	2	2
4	X-391-26	Connector, 90°	2	2
5	X-426-16	Clamp, Hose	4	4
6	X-6053-2	Nut, Hex.	3	3
7	X-6049-3	Screw, Hex Head Machine	2	2
7	X-6055-6	Screw, Socket Head	1	1
8	X-6055-7	Screw, Socket Head	1	1
9	229395	Manifold, Intake & Exhaust	1	1
10	229540	Gasket	1	1
11	267936	Tube, Mixing (Alum)	1	1
12	#	Washer, 5/16	2	2

116_129_4

Group 201: Generator and Mounting

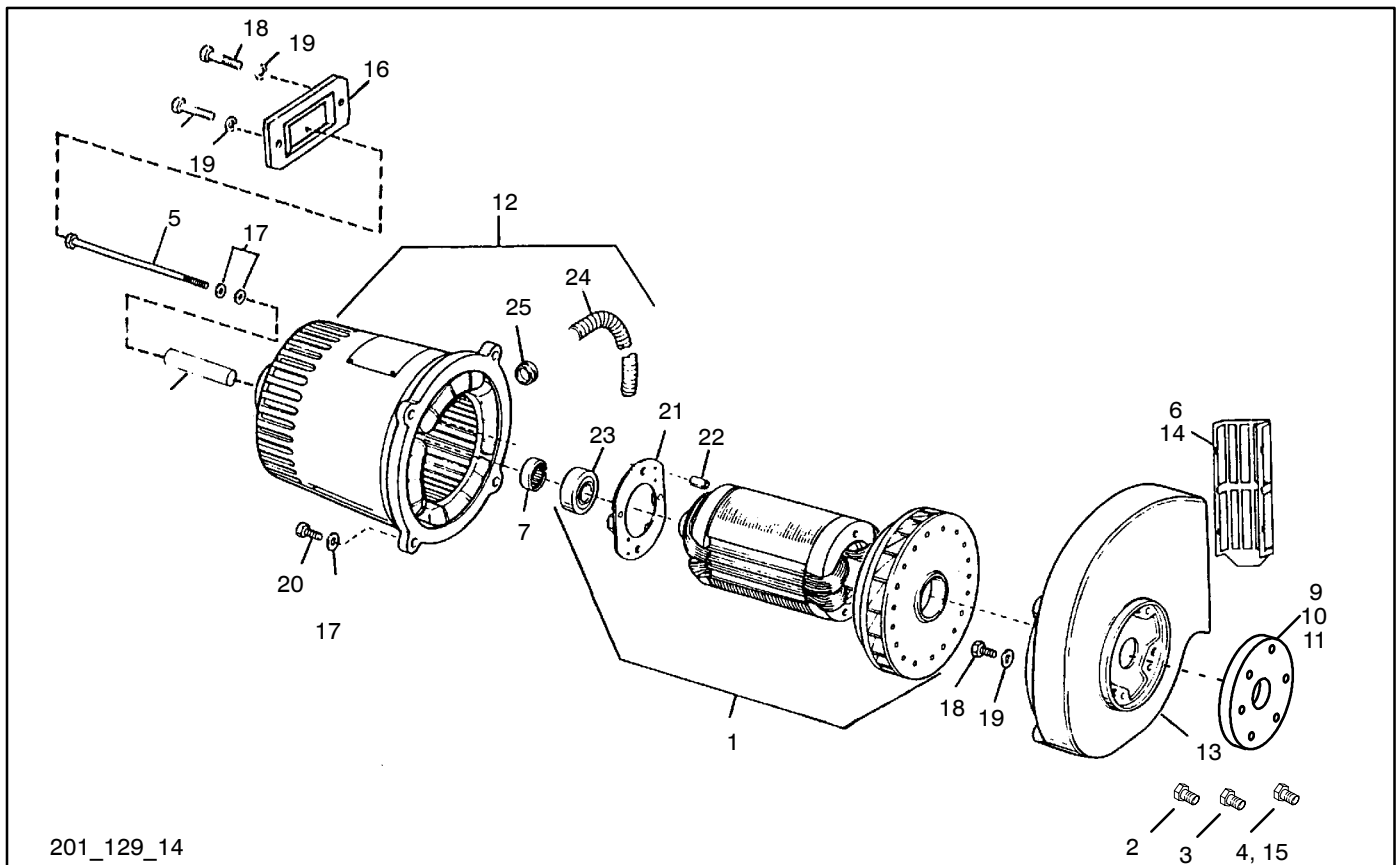

Item	Part Number	Description	Qty						
			Variation						
			13	14	15	16	17	18	19
1	F-267327	Rotor Assembly (includes items 21-23)	1		1	1		1	1
1	E-267328	Rotor Assembly (includes items 21-23)		1			1		
2	X-6050-15	Screw, Hex Cap	1	1	1	1	1	1	1
3	X-6050-2	Screw, Hex Head Cap	1	1	1	1	1	1	1
4	X-6050-7	Screw, Hex Head Cap	3	3	3	3	3	3	3
5	X-6068-3	Screw, Hex Head Cap	1	1	1	1	1	1	1
6	X-781-10	Rivet, Pop	4	4	4	4	4	4	4
7	238211	Ring, Tolerance	1	1	1	1	1	1	1
8	239673	Damper, Vibro	2	2	2	2	2	2	2
9	246408	Pin, Dowel	1	1	1	1	1	1	1
10	246409	Pin, Dowel	1	1	1	1	1	1	1
11	246410	Flange, PTO	1	1	1	1	1	1	1
12	260068	Stator Assembly (includes item 24, 25)		1			1		
12	260069	Stator Assembly (includes item 24, 25)	1		1				1
12	260070	Stator Assembly (includes item 24, 25)				1		1	
13	260080	Adapter, Generator	1	1	1	1	1	1	1
14	267413	Guard, Adapter	1	1	1	1	1	1	1
15	267459	Spacer	4	4	4	4	4	4	4
16	267460	Shield, Bolt	1	1	1	1	1	1	1
17	#	Washer, 3/8	6	6	6	6	6	6	6
18	X-125-30	Screw, Ref.	6	6	6	6	6	6	6
19	#	Washer, 5/16	6	6	6	6	6	6	6
20	#	Bolt, 3/8-16	4	4	4	4	4	4	4
21	B-239736	PCB Assembly, Rotate 3 diode	1	1	1	1	1	1	1
22	X-400-135	Spacer	2	2	2	2	2	2	2
23	X-758-1	Bearing, Ball	1	1	1	1	1	1	1
24	X-6003-6	Conduit, Convoluted	1	1	1	1	1	1	1
25	X-634-11	Bushing, Nylon	1	1	1	1	1	1	1

201_129_13

Notes

Group 301: Controller and Mounting

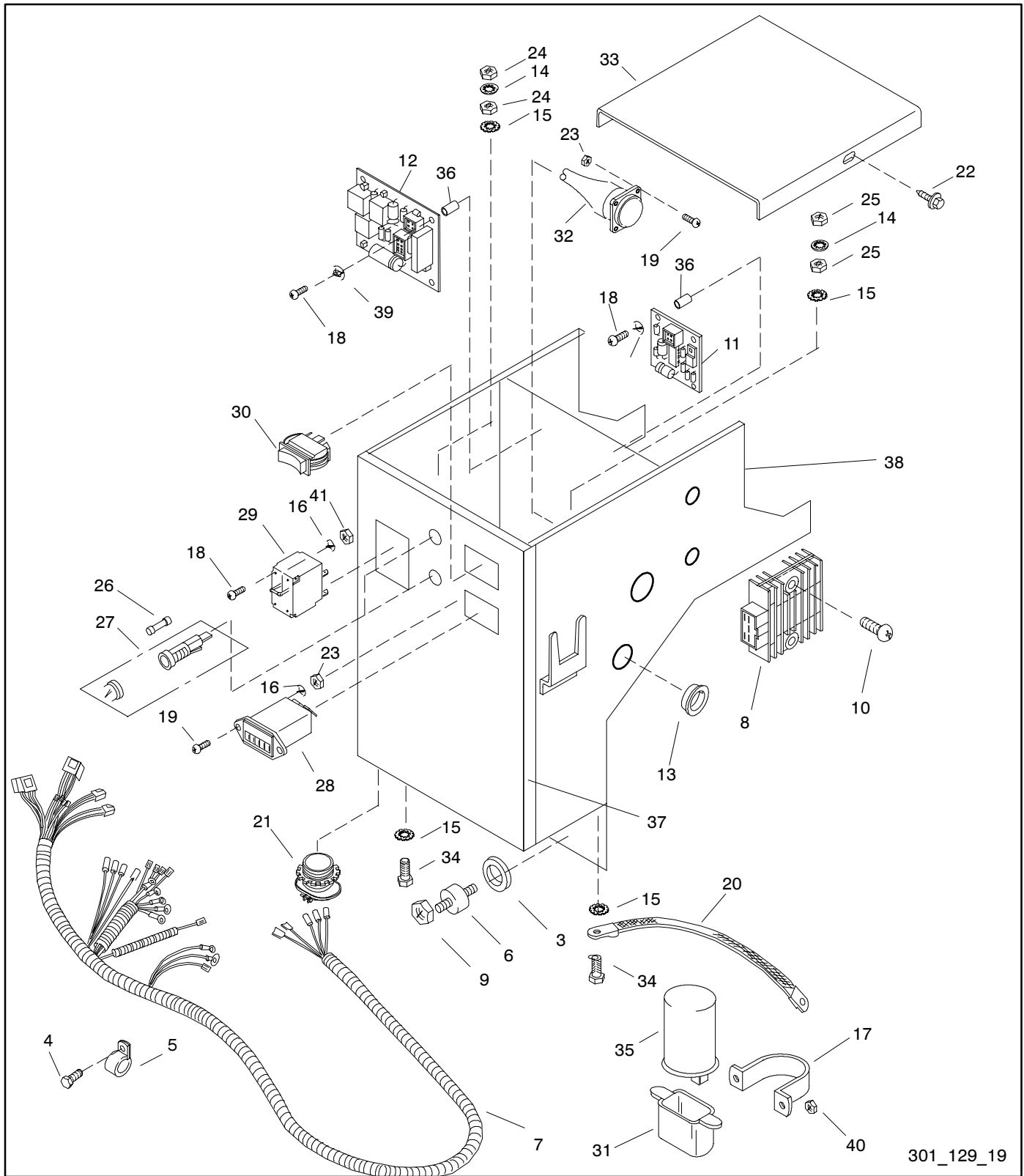

301_129_19

Group 301: Controller and Mounting

Item	Part Number	Description	Qty											
			Variation											
			19	20	21	22	23	24	25	26	27	28	29	30
1	A-344576	Controller Assembly (includes items 11-41)	1						1					
1	A-344575	Controller Assembly (includes items 11-41)		1						1				
1	A-344578	Controller Assembly (includes items 11-41)			1	1					1	1		
1	A-344577	Controller Assembly (includes items 11-41)					1	1					1	1
2	X-22-10	Washer, Lock, 3/8 Int. Tooth (not shown)	1	1	1	1	1	1	1	1	1	1	1	1
3	X-25-73	Washer, Plain	4	4	4	4	4	4	4	4	4	4	4	4
4	X-6049-2	Screw, H.C. M6 x 1	1	1	1	1	1	1	1	1	1	1	1	1
5	X-672-13	Clamp, Insulated	1	1	1	1	1	1	1	1	1	1	1	1
6	241769	Mount, Controller	4	4	4	4	4	4	4	4	4	4	4	4
7	246483	Harness, Wiring (includes items 42, 43)	1	1					1	1				
7	344017	Harness, Wiring (includes items 42, 43)			1	1	1	1			1	1	1	1
8	267377	Regulator, Voltage	1	1	1	1	1	1	1	1	1	1	1	1
9	#	Nut, 1/4-20	4	4	4	4	4	4	4	4	4	4	4	4
10	#	Hardware, 1/4-20	2	2	2	2	2	2	2	2	2	2	2	2
11	B-267448	PCB Assy., Marine Choke	1	1	1	1	1	1	1	1	1	1	1	1
12	C-229388	PCB Assy., Relay Control	1	1	1	1	1	1	1	1	1	1	1	1
13	D-1128	Grommet	1	1	1	1	1	1	1	1	1	1	1	1
14	X-22-11	Washer, Lock, 1/4 Int. Tooth	2	2	2	2	2	2	2	2	2	2	2	2
15	X-22-12	Washer, Lock, 1/4 I/E Tooth	4	4	4	4	4	4	4	4	4	4	4	4
16	X-22-6	Washer Lock, #6	6	6	6	6	6	6	6	6	6	6	6	6
17	X-414-6	Clip, Wire	1	1	1	1	1	1	1	1	1	1	1	1
18	X-49-25	Screw, r.h.m., 6-32 x .25 Slotted	20	20	20	20	20	20	20	20	20	20	20	20
19	X-49-26	Screw, r.h.m., 6-32 x .50 Slotted	6	6	6	6	6	6	6	6	6	6	6	6
20	X-6046-4	Strap, Ground	1	1	1	1	1	1	1	1	1	1	1	1
21	X-6266-1	Connector, Cable	1	1	1	1	1	1	1	1	1	1	1	1
22	X-67-147	Screw, Thread Cutting	3	3	3	3	3	3	3	3	3	3	3	3
23	X-71-2	Nut, Hex, 6-32 Zinc	6	6	6	6	6	6	6	6	6	6	6	6
24	X-76-2	Nut, Hex	2	2	2	2	2	2	2	2	2	2	2	2
25	X-81-8	Nut, Hex, 1/4-20 Green	2	2	2	2	2	2	2	2	2	2	2	2
26	223316	Fuse, 10A 250V .25 x 1.25	2	2	2	2	2	2	2	2	2	2	2	2
27	238426	Holder, Fuse, .25 x 1.25	2	2	2	2	2	2	2	2	2	2	2	2
28	238736	Meter, Hour	1	1	1	1	1	1	1	1	1	1	1	1
29	245264	Plate, Cover	1	1					1	1				
29	229183	Plate, Cover			1		1	1			1		1	1
29	X-506-47	Breaker, Circuit (55 Amp)			1			1			1			1
29	X-506-41	Breaker, Circuit (18 Amp)				1						1		
29	X-506-46	Breaker, Circuit (35 Amp)					1						1	
30	249406	Switch, Rocker	1	1					1	1				
30	229997	Switch, Rocker			1	1	1	1			1	1	1	1
31	250788	Boot, Protective	1	1	1	1	1	1	1	1	1	1	1	1
32	260099	Harness, Wiring	1	1					1	1				
32	344009	Harness, Wiring			1	1	1	1			1	1	1	1
33	260100	Cover	1	1	1	1	1	1	1	1	1	1	1	1
34	267491	Screw, Special	2	2	2	2	2	2	2	2	2	2	2	2
35	267968	Capacitor	1		1	1			1		1	1		
35	267384	Capacitor		1			1	1		1			1	1
36	287948	Spacer, .25 x .50	8	8	8	8	8	8	8	8	8	8	8	8
37	344294	Cover, Silkscreened	1	1	1	1	1	1	1	1	1	1	1	1
38	344630	Box, Controller	1	1					1	1				
38	344579	Box, Controller			1	1	1	1			1	1	1	1
39	#	Washer, #6	8	8	8	8	8	8	8	8	8	8	8	8
40	#	Nut, 1/4-20	1	1	1	1	1	1	1	1	1	1	1	1
41	#	Nut, #6-32	4	4	4	4	4	4	4	4	4	4	4	4
42	239493	22-Pin Connector (not shown)	1	1	1	1	1	1	1	1	1	1	1	1
43	292370	2-Pin Connector (not shown)	1	1	1	1	1	1	1	1	1	1	1	1
44	248362	Relay (not shown)			1	1	1	1			1	1	1	1

301_129_19

Group 501: Housing

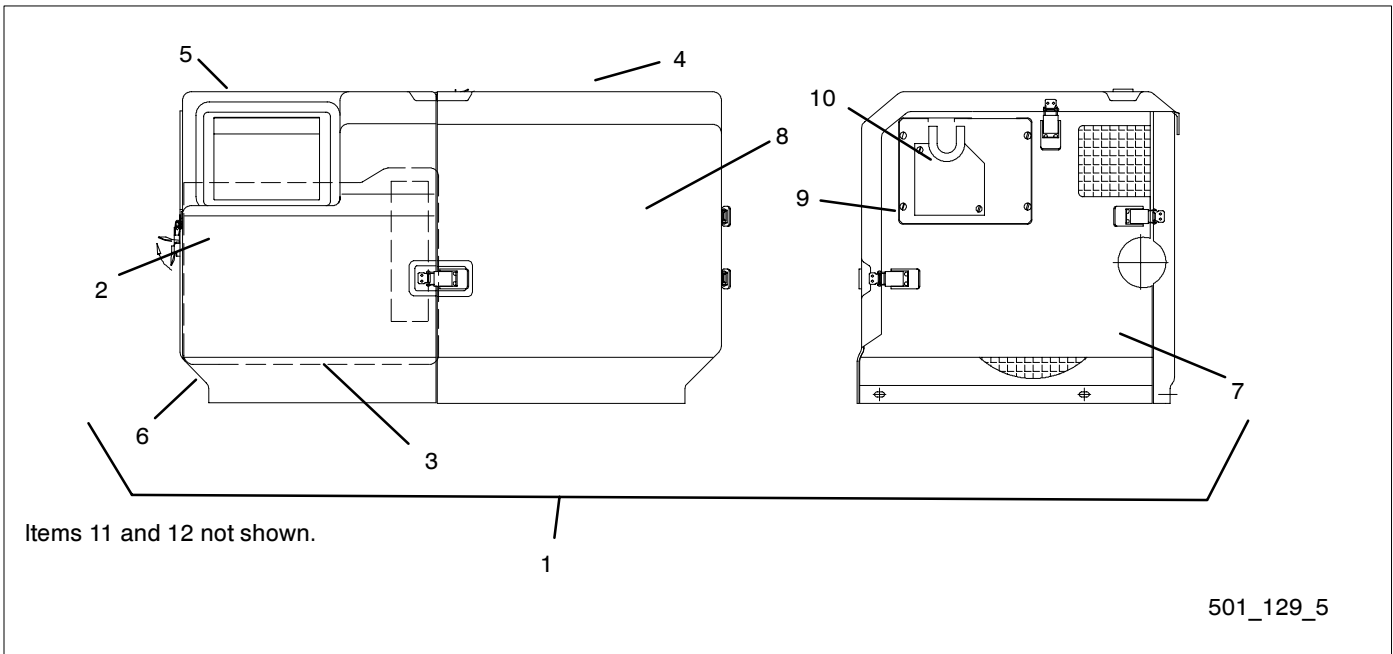

Item	Part Number	Description	Qty Variation	
			5	7
1	A-344300	Shield Assembly, Sound (includes items 2-8)	1	1
2	X-6348-5	Decal, Kohler Power System	1	1
3	267973	Duct, exhaust air	1	1
4	343165	Decal, caution	1	1
5	344596	Shield, sound (top left)	1	1
6	344597	Shield, sound (bottom)	1	1
7	344598	Shield, sound (side)	1	1
8	344599	Shield, sound (top right)	1	1
9	359109	Door, sound shield	1	1
10	359110	Cover, panel	1	1
11	359111	Insulation, acoustic (not shown)	1	1
12	359112	Insulation, acoustic (not shown)	1	1

501_129_5

Group 701: Literature

Item	Part Number	Description	Qty Variation	
			3	
1	TP-5338	Service Manual, 4/6.5CZ, 3.5/5CFZ	1	
2	TP-5833	Parts Catalog, 4/6.5ESZ, 3.5/5EFZ	1	
3	TP-5363	Service Manual, Honda GX360	1	
4	TP-5620	Safety Precautions, Marine	1	
5	TP-5810	Operation/Installation Manual, 4/6.5ESZ, 3.5/5EFZ	1	

701_129_3

Accessories

Qty.	Description	Part No.	Qty.	Description	Part No.
Breaker, Circuit (120V, 2 wire)			PA-229184		
1	Breaker, circuit 35 amp.	X-506-46	Harness, Fire System Interface		
1	Plate, cover	229183	1	Harness, wiring	229832
1	Decal, notice	246242	1	Instructions, installation	TT-930
1	Instructions, installation	TT-875	Harness, Remote 12 In. Pigtail		
Breaker, Circuit (110V, 3 wire)			PA-249941		
1	Breaker, circuit 18 amp.	X-506-41	1	Harness extension	249935
1	Decal, notice	246242	Harness for Remote Panel (15 Ft.)		
1	Terminal, jumper	249956	1	Strap, wire 5/8	X-526-3
1	Instructions, installation	TT-875	1	Harness, extension	249334
Breaker, Circuit (220V, 2 wire)			PA-228670		
1	Breaker, circuit	X-506-53	Harness for Remote Panel (25 Ft.)		
1	Plate, cover	229183	1	Strap, wire 5/8	X-526-3
1	Decal, notice	246242	1	Harness, extension	249936
1	Instructions, installation	TT-875	Panel, Remote Start and 2-Meter		
Breaker, Circuit (120/240V, 3 wire)			PA-344051		
1	Breaker, circuit 8 amp.	X-506-41	1	Instructions, installation	TT-1072
1	Instructions, installation	TT-875	1	Decal, warning	249494
1	Decal, notice	246242	1	Panel Assembly (includes the following)	A-344033
Breaker, Circuit (120V, 2 wire)			PA-229185		
1	Breaker, circuit 55 amp.	X-506-47	1	Panel	344029
1	Plate, cover	229183	1	Harness, wiring	344031
1	Decal, notice	246242	1	Gauge, water temperature	344035
1	Instructions, installation	TT-875	1	Gauge, oil pressure	344036
Breaker, Circuit (120V, 3 wire)			PA-344052		
1	Breaker, circuit 30 amp.	X-506-36	1	Switch, rocker	344039
1	Terminal, jumper	249956	Panel, Remote Start and 4-meter		
1	Instructions, installation	TT-875	1	Instructions, installation	TT-1073
1	Decal, notice	246242	1	Decal, warning	249494
Breaker, Circuit (100/220V, 3 wire)			PA-344050		
1	Breaker, circuit 63 amp.	X-506-40	1	Panel Assembly (includes the following)	A-344034
1	Decal, notice	246242	1	Panel	344030
1	Instructions, installation	TT-875	1	Harness, wiring	344032
Breaker, Circuit (120/240V, 3 wire)			PA-344052		
1	Breaker, circuit	X-506-36	1	Gauge, water temperature	344035
1	Decal, notice	246242	1	Gauge, oil pressure	344036
1	Instructions, installation	TT-875	1	Voltmeter	344037
Breaker, Circuit (110V, 3 wire)			PA-225630		
1	Breaker, circuit	X-506-40	1	Hourmeter	344038
1	Terminal, jumper	249956	1	Switch, rocker	344039
1	Decal, notice	246242	Sender, Oil/Water Temperature		
1	Instructions, installation	TT-875	1	Sender, water temp.	249348
Flush Kit			PA-267999		
1	Connector, hose	X-582-12	1	Sender, oil pressure	267967
1	Connector, hose	X-582-4	1	Instructions, installation	TT-901
1	Hose, .5" dia. x 28"	X-612-15	Siphon break		
1	Connector, hose	X-6269-1	1	Instructions, installation	TT-1182
1	Hose, .375" dia. x 30"	X-651-5	2	Grommet	X-284-42
1	Instructions, installation	TT-741	1	Hose	X-312-53
Harness, Extension (25 Ft.)			PA-344013		
1	Harness	344013	2	Clamp, hose	X-426-3
Harness, Extension (12 Ft.)			PA-344014		
1	Harness	344014	1	Valve, siphon break	229928
			1	Door, sound shield	344601
			1	Cover, panel	344607

Accessories

Sound Shield

PA-344301

1	Instructions, installation	TT-805
1	Door, sound shield	359109
1	Cover, panel	359110
1	Insulation, acoustic	359111
1	Insulation, acoustic	359112
1	Shield assembly (Includes all the following)	A-344300
2	Decal, Kohler logo	X-6348-5
1	Duct, exhaust air	267973
1	Decal, caution-not a step	343165
1	Shield, sound (top left)	344596
1	Shield, sound (bottom)	344597
1	Shield, sound (side wing)	344598
1	Shield, sound (top right)	344599

Switch, Ship-to-shore, 110/120V, 2wire

PAA-246614

1	Instructions, installation	TT-535
1	Switch, transfer	A-246614

Switch, Ship-to-shore, 110/120V, 2 wire or 220/240V, 3 wire

PAA-246617

1	Instructions, installation	TT-535
1	Switch, transfer	A-246617

Appendix A. Abbreviations

The following list contains abbreviations that may appear in this publication.

A, amp	ampere	cm	centimeter	freq.	frequency
ABDC	after bottom dead center	cmm	cubic meters per minute	FS	full scale
AC	alternating current	CMOS	complementary metal oxide substrate (semiconductor)	ft.	foot, feet
A/D	analog to digital			ft. lbs.	foot pounds (torque)
ADC	analog to digital converter	cogen.	cogeneration	ft./min.	feet per minute
adj.	adjust, adjustment	COM	communications (port)	g	gram
ADV	advertising dimensional drawing	conn.	connection	ga.	gauge (meters, wire size)
AHWT	anticipatory high water temperature	cont.	continued	gal.	gallon
		CPVC	chlorinated polyvinyl chloride	gen.	generator
AISI	American Iron and Steel Institute	crit.	critical	genset	generator set
ALOP	anticipatory low oil pressure	CRT	cathode ray tube	GFI	ground fault interrupter
alt.	alternator	CSA	Canadian Standards Association	gnd.	ground
Al	aluminum	CT	current transformer	gov.	governor
ANSI	American National Standards Institute (formerly American Standards Association, ASA)	Cu	copper	gph	gallons per hour
		cu. in.	cubic inch	gpm	gallons per minute
AO	anticipatory only	cw.	clockwise	gr.	grade, gross
API	American Petroleum Institute	CWC	city water-cooled	gr. wt.	gross weight
approx.	approximate, approximately	cyl.	cylinder	H x W x D	height by width by depth
AR	as required, as requested	D/A	digital to analog	HC	hex cap
AS	as supplied, as stated, as suggested	DAC	digital to analog converter	HCHT	high cylinder head temperature
		dB	decibel	HD	heavy duty
ASE	American Society of Engineers	dba	decibel (A weighted)	HET	high exhaust temperature
ASME	American Society of Mechanical Engineers	DC	direct current	hex	hexagon
		DCR	direct current resistance	Hg	mercury (element)
assy.	assembly	deg., °	degree	HH	hex head
ASTM	American Society for Testing Materials	dept.	department	HHC	hex head cap
		dia.	diameter	HP	horsepower
ATDC	after top dead center	DI/EO	dual inlet/end outlet	hr.	hour
ATS	automatic transfer switch	DIN	Deutsches Institut fur Normung e. V. (also Deutsche Industrie Normenausschuss)	HS	heat shrink
auto.	automatic			hsg.	housing
aux.	auxiliary	DIP	dual inline package	HVAC	heating, ventilation, and air conditioning
A/V	audio/visual	DPDT	double-pole, double-throw	HWT	high water temperature
avg.	average	DPST	double-pole, single-throw	Hz	hertz (cycles per second)
AVR	automatic voltage regulator	DS	disconnect switch	IC	integrated circuit
AWG	American Wire Gauge	DVR	digital voltage regulator	ID	inside diameter, identification
AWM	appliance wiring material	E, emer.	emergency (power source)	IEC	International Electrotechnical Commission
bat.	battery	EDI	electronic data interchange	IEEE	Institute of Electrical and Electronics Engineers
BBDC	before bottom dead center	EFR	emergency frequency relay	IMS	improved motor starting
BC	battery charger, battery charging	e.g.	for example (<i>exempli gratia</i>)	in.	inch
BCA	battery charging alternator	EG	electronic governor	in. H ₂ O	inches of water
BCI	Battery Council International	EGSA	Electrical Generating Systems Association	in. Hg	inches of mercury
BDC	before dead center	EIA	Electronic Industries Association	in. lbs.	inch pounds
BHP	brake horsepower	EI/EO	end inlet/end outlet	Inc.	incorporated
blk.	black (paint color), block (engine)	EMI	electromagnetic interference	ind.	industrial
blk. htr.	block heater	emiss.	emission	int.	internal
BMEP	brake mean effective pressure	eng.	engine	int./ext.	internal/external
bps	bits per second	EPA	Environmental Protection Agency	I/O	input/output
br.	brass	EPS	emergency power system	IP	iron pipe
BTDC	before top dead center	ER	emergency relay	ISO	International Organization for Standardization
Btu	British thermal unit	ES	engineering special, engineered special	J	joule
Btu/min.	British thermal units per minute	ESD	electrostatic discharge	JIS	Japanese Industry Standard
C	Celsius, centigrade	est.	estimated	k	kilo (1000)
cal.	calorie	E-Stop	emergency stop	K	kelvin
CARB	California Air Resources Board	etc.	et cetera (and so forth)	kA	kiloampere
CB	circuit breaker	exh.	exhaust	KB	kilobyte (2 ¹⁰ bytes)
cc	cubic centimeter	ext.	external	kg	kilogram
CCA	cold cranking amps	F	Fahrenheit, female	kg/cm ²	kilograms per square centimeter
ccw.	counterclockwise	fglass.	fiberglass	kgm	kilogram-meter
CEC	Canadian Electrical Code	FHM	flat head machine (screw)	kg/m ³	kilograms per cubic meter
cfh	cubic feet per hour	fl. oz.	fluid ounce	kHz	kilohertz
cfm	cubic feet per minute	flex.	flexible		
CG	center of gravity				
CID	cubic inch displacement				
CL	centerline				

kJ	kilojoule	N, norm.	normal (power source)	rnd.	round
km	kilometer	NA	not available, not applicable	ROM	read only memory
kOhm, kΩ	kilo-ohm	nat. gas	natural gas	rot.	rotate, rotating
kPa	kilopascal	NBS	National Bureau of Standards	rpm	revolutions per minute
kph	kilometers per hour	NC	normally closed	RS	right side
kV	kilovolt	NEC	National Electrical Code	RTV	room temperature vulcanization
kVA	kilovolt ampere	NEMA	National Electrical Manufacturers Association	SAE	Society of Automotive Engineers
kVAR	kilovolt ampere reactive	NFPA	National Fire Protection Association	scfm	standard cubic feet per minute
kW	kilowatt	Nm	newton meter	SCR	silicon controlled rectifier
kWh	kilowatt-hour	NO	normally open	s, sec.	second
kWm	kilowatt mechanical	no., nos.	number, numbers	SI	<i>Systeme international d'unites</i> , International System of Units
L	liter	NPS	National Pipe, Straight	SI/EO	side in/end out
LAN	local area network	NPSC	National Pipe, Straight-coupling	sil.	silencer
L x W x H	length by width by height	NPT	National Standard taper pipe thread per general use	SN	serial number
lb.	pound	NPTF	National Pipe, Taper-Fine	SPDT	single-pole, double-throw
lbm/ft ³	pounds mass per cubic feet	NR	not required, normal relay	SPST	single-pole, single-throw
LCB	line circuit breaker	ns	nanosecond	spec, specs	specification(s)
LCD	liquid crystal display	O/C	overcrank	sq.	square
ld. shd.	load shed	OD	outside diameter	sq. cm	square centimeter
LED	light emitting diode	OEM	original equipment manufacturer	sq. in.	square inch
Lph	liters per hour	O/F	overfrequency	SS	stainless steel
Lpm	liters per minute	opt.	option, optional	std.	standard
LOP	low oil pressure	O/S	oversize, overspeed	stl.	steel
LP	liquefied petroleum	OSHA	Occupational Safety and Health Administration	tach.	tachometer
LPG	liquefied petroleum gas	O/V	overvoltage	TD	time delay
LS	left side	oz.	ounce	TDC	top dead center
L _{wa}	sound power level, A weighted	p., pp.	page, pages	TDEC	time delay engine cooldown
LWL	low water level	PA	packed accessory	TDEN	time delay emergency to normal
LWT	low water temperature	PC	personal computer	TDES	time delay engine start
m	meter, milli (1/1000)	PCB	printed circuit board	TDNE	time delay normal to emergency
M	mega (10 ⁶ when used with SI units), male	pF	picofarad	TDOE	time delay off to emergency
m ³	cubic meter	PF	power factor	TDON	time delay off to normal
m ³ /min.	cubic meters per minute	ph.	phase	temp.	temperature
mA	milliampere	PHC	Phillips head crimplite (screw)	term.	terminal
man.	manual	PHH	Phillips hex head (screw)	TIF	telephone influence factor
max.	maximum	PHM	pan head machine (screw)	TIR	total indicator reading
MB	megabyte (2 ²⁰ bytes)	PLC	programmable logic control	tol.	tolerance
MCM	one thousand circular mils	PMG	permanent magnet generator	turbo.	turbocharger
meggar	megohmmeter	pot	potentiometer, potential	typ.	typical (same in multiple locations)
MHz	megahertz	ppm	parts per million	U/F	underfrequency
mi.	mile	PROM	programmable read only memory	UHF	ultrahigh frequency
mil	one one-thousandth of an inch	psi	pounds per square inch	UL	Underwriter's Laboratories, Inc.
min.	minimum, minute	pt.	pint	UNC	unified coarse thread (was NC)
misc.	miscellaneous	PTC	positive temperature coefficient	UNF	unified fine thread (was NF)
MJ	megajoule	PTO	power takeoff	univ.	universal
mJ	millijoule	PVC	polyvinyl chloride	U/S	undersize, underspeed
mm	millimeter	qt.	quart	UV	ultraviolet
mOhm, mΩ	milliohm	qty.	quantity	U/V	undervoltage
MOhm, MΩ	megohm	R	replacement (emergency) power source	V	volt
MOV	metal oxide varistor	rad.	radiator, radius	VAC	volts alternating current
MPa	megapascal	RAM	random access memory	VAR	voltampere reactive
mpg	miles per gallon	RDO	relay driver output	VDC	volts direct current
mph	miles per hour	ref.	reference	VFD	vacuum fluorescent display
MS	military standard	rem.	remote	VGA	video graphics adapter
m/sec.	meters per second	RH	round head	VHF	very high frequency
MTBF	mean time between failure	RHM	round head machine (screw)	W	watt
MTBO	mean time between overhauls	rly.	relay	WCR	withstand and closing rating
mtg.	mounting	rms	root mean square	w/	with
MW	megawatt			w/o	without
mW	milliwatt			wt.	weight
μF	microfarad			xfmr	transformer

Appendix B. Common Hardware Application Guidelines

Use the information below and on the following pages to identify proper fastening techniques when no specific reference for reassembly is made.

Bolt/Screw Length: When bolt/screw length is not given, use Figure 1 as a guide. As a general rule, a minimum length of one thread beyond the nut and a maximum length of 1/2 the bolt/screw diameter beyond the nut is the preferred method.

Washers and Nuts: Use split lock washers as a bolt locking device where specified. Use SAE flat washers with whiz nuts, spirallock nuts, or standard nuts and preloading (torque) of the bolt in all other applications.

See General Torque Specifications and other torque specifications in the service literature.

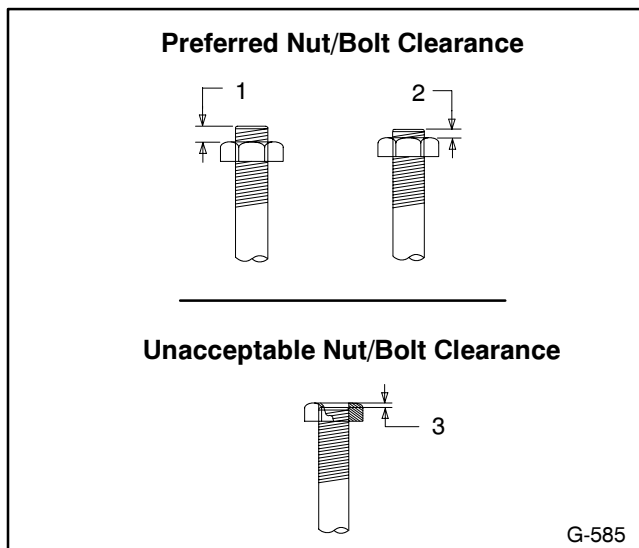

1. 1/2 of Bolt Diameter
2. Min. 1 Full Thread Beyond Top of Nut
3. Below Top of Nut

Figure 2. Acceptable Bolt Lengths

Steps for common hardware application:

1. Determine entry hole type: round or slotted.
2. Determine exit hole type: fixed female thread (weld nut), round, or slotted.

For round and slotted exit holes, determine if hardware is greater than 1/2 inch in diameter, or 1/2 inch in diameter or less. Hardware that is *greater than 1/2 inch* in diameter takes a standard nut and SAE washer. Hardware *1/2 inch or less* in diameter can take a properly torqued whiz nut or spirallock nut. See the diagram below.

3. Follow these SAE washer rules after determining exit hole type:
 - a. Always use a washer between hardware and a slot.
 - b. Always use a washer under a nut (see 2 above for exception).
 - c. Use a washer under a bolt when the female thread is fixed (weld nut).
4. Refer to the diagram below, which depicts the preceding hardware configuration possibilities.

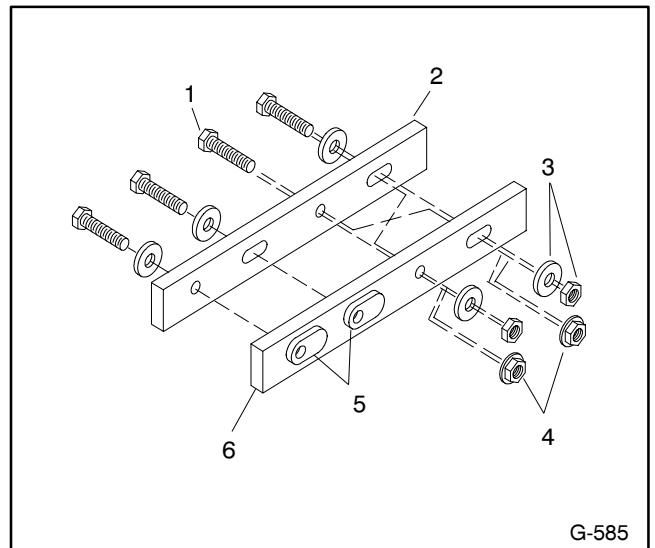

1. Cap screw
2. Entry hole types
3. Standard nut and SAE washer
4. Whiz nut or spirallock: up to 1/2" dia. hardware
5. Weld nuts: above 1/2" dia. hardware
6. Exit hole types

Figure 3. Acceptable Hardware Combinations

Appendix C. General Torque Specifications

Use the following torque specifications when service literature instructions give no specific torque values. The charts list values for new plated, zinc phosphate, or oiled

threads. Increase values by 15% for nonplated threads. All torque values are +0%/-10%.















American Standard Fasteners Torque Specifications











Size	Torque Measurement	Assembled into Cast Iron or Steel			Assembled into Aluminum Grade 2 or 5
		Grade 2	Grade 5	Grade 8	
8-32	in. lbs. (Nm)	16 (1.8)	20 (2.3)	—	16 (1.8)
10-24	in. lbs. (Nm)	26 (2.9)	32 (3.6)	—	26 (2.9)
10-32	in. lbs. (Nm)	26 (2.9)	32 (3.6)	—	26 (2.9)
1/4-20	in. lbs. (Nm)	60 (6.8)	96 (10.8)	132 (14.9)	60 (6.8)
1/4-28	in. lbs. (Nm)	72 (8.1)	108 (12.2)	144 (16.3)	72 (8.1)
5/16-18	in. lbs. (Nm)	120 (13.6)	192 (21.7)	264 (29.8)	120 (13.6)
5/16-24	in. lbs. (Nm)	132 (14.9)	204 (23.1)	288 (32.5)	132 (14.9)
3/8-16	ft. lbs. (Nm)	18 (24)	28 (38)	39 (53)	18 (24)
3/8-24	ft. lbs. (Nm)	20 (27)	31 (42)	44 (60)	20 (27)
7/16-14	ft. lbs. (Nm)	29 (39)	44 (60)	63 (85)	—
7/16-20	ft. lbs. (Nm)	32 (43)	50 (68)	70 (95)	—
1/2-13	ft. lbs. (Nm)	44 (60)	68 (92)	96 (130)	—
1/2-20	ft. lbs. (Nm)	49 (66)	76 (103)	108 (146)	—
9/16-12	ft. lbs. (Nm)	60 (81)	98 (133)	138 (187)	—
9/16-18	ft. lbs. (Nm)	67 (91)	109 (148)	154 (209)	—
5/8-11	ft. lbs. (Nm)	83 (113)	135 (183)	191 (259)	—
5/8-18	ft. lbs. (Nm)	94 (128)	153 (208)	216 (293)	—
3/4-10	ft. lbs. (Nm)	147 (199)	240 (325)	338 (458)	—
3/4-16	ft. lbs. (Nm)	164 (222)	268 (363)	378 (513)	—
1-8	ft. lbs. (Nm)	191 (259)	532 (721)	818 (1109)	—
1-12	ft. lbs. (Nm)	209 (283)	582 (789)	895 (1214)	—





Metric Fasteners Torque Specifications, Measured in ft. lbs. (Nm)

Size (mm)	Assembled into Cast Iron or Steel			Assembled into Aluminum Grade 5.8 or 8.8
	Grade 5.8	Grade 8.8	Grade 10.9	
M6 x 1.00	4 (5.6)	7 (9.9)	10 (14)	4 (5.6)
M8 x 1.25	10 (13.6)	18 (25)	26 (35)	10 (13.6)
M8 x 1.00	16 (21)	18 (25)	26 (35)	16 (21)
M10 x 1.50	20 (27)	35 (49)	50 (68)	20 (27)
M10 x 1.25	29 (39)	35 (49)	50 (68)	29 (39)
M12 x 1.75	35 (47)	61 (83)	86 (117)	—
M12 x 1.50	48 (65)	65 (88)	92 (125)	—
M14 x 2.00	55 (74)	97 (132)	136 (185)	—
M14 x 1.50	74 (100)	103 (140)	142 (192)	—
M16 x 2.00	85 (115)	148 (200)	210 (285)	—
M16 x 1.50	104 (141)	155 (210)	218 (295)	—
M18 x 2.50	114 (155)	203 (275)	288 (390)	—
M18 x 1.50	145 (196)	225 (305)	315 (425)	—

Appendix D. Common Hardware Identification

Screw/Bolts/Studs	
Head Styles	
Hex Head or Machine Head	
Hex Head or Machine Head with Washer	
Flat Head (FHM)	
Round Head (RHM)	
Pan Head	
Hex Socket Head Cap or Allen™ Head Cap	
Hex Socket Head or Allen™ Head Shoulder Bolt	
Sheet Metal Screw	
Stud	
Drive Styles	
Hex	
Hex and Slotted	
Phillips®	
Slotted	
Hex Socket	

Nuts	
Nut Styles	
Hex Head	
Lock or Elastic	
Square	
Cap or Acorn	
Wing	
Washers	
Washer Styles	
Plain	
Split Lock or Spring	
Spring or Wave	
External Tooth Lock	
Internal Tooth Lock	
Internal-External Tooth Lock	

Hardness Grades	
American Standard	
Grade 2	
Grade 5	
Grade 8	
Grade 8/9 (Hex Socket Head)	
Metric	
Number stamped on hardware; 5.8 shown	

Allen™ head screw is a trademark of Holo-Krome Co.
Phillips® screw is a registered trademark of Phillips Screw Company.

Sample Dimensions

American Standard (Screws, Bolts, Studs, and Nuts)

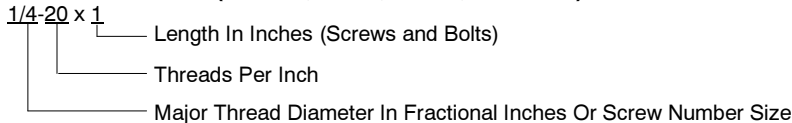

Metric (Screws, Bolts, Studs, and Nuts)

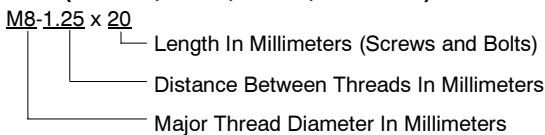

Plain Washers

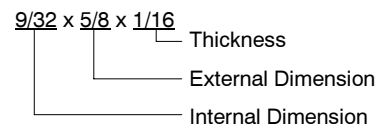

Lock Washers

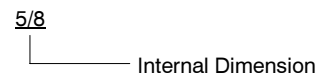

Appendix E. Common Hardware List

The Common Hardware List lists part numbers and dimensions for common hardware items.

American Standard

Part No. Dimensions Hex Head Bolts (Grade 5)

X-465-17	1/4-20 x .38
X-465-6	1/4-20 x .50
X-465-2	1/4-20 x .62
X-465-16	1/4-20 x .75
X-465-18	1/4-20 x .88
X-465-7	1/4-20 x 1.00
X-465-8	1/4-20 x 1.25
X-465-9	1/4-20 x 1.50
X-465-10	1/4-20 x 1.75
X-465-11	1/4-20 x 2.00
X-465-12	1/4-20 x 2.25
X-465-14	1/4-20 x 2.75
X-465-21	1/4-20 x 5.00
X-465-25	1/4-28 x .38
X-465-20	1/4-28 x 1.00
X-125-33	5/16-18 x .50
X-125-23	5/16-18 x .62
X-125-3	5/16-18 x .75
X-125-31	5/16-18 x .88
X-125-5	5/16-18 x 1.00
X-125-24	5/16-18 x 1.25
X-125-34	5/16-18 x 1.50
X-125-25	5/16-18 x 1.75
X-125-26	5/16-18 x 2.00
230578	5/16-18 x 2.25
X-125-29	5/16-18 x 2.50
X-125-27	5/16-18 x 2.75
X-125-28	5/16-18 x 3.00
X-125-22	5/16-18 x 4.50
X-125-32	5/16-18 x 5.00
X-125-35	5/16-18 x 5.50
X-125-36	5/16-18 x 6.00
X-125-40	5/16-18 x 6.50
X-125-43	5/16-24 x 1.75
X-125-44	5/16-24 x 2.50
X-125-30	5/16-24 x .75
X-125-39	5/16-24 x 2.00
X-125-38	5/16-24 x 2.75
X-6238-2	3/8-16 x .62
X-6238-10	3/8-16 x .75
X-6238-3	3/8-16 x .88
X-6238-11	3/8-16 x 1.00
X-6238-4	3/8-16 x 1.25
X-6238-5	3/8-16 x 1.50
X-6238-1	3/8-16 x 1.75
X-6238-6	3/8-16 x 2.00
X-6238-17	3/8-16 x 2.25
X-6238-7	3/8-16 x 2.50
X-6238-8	3/8-16 x 2.75
X-6238-9	3/8-16 x 3.00
X-6238-19	3/8-16 x 3.25
X-6238-12	3/8-16 x 3.50
X-6238-20	3/8-16 x 3.75
X-6238-13	3/8-16 x 4.50
X-6238-18	3/8-16 x 5.50
X-6238-25	3/8-16 x 6.50

Part No. Dimensions Hex Head Bolts, cont.

X-6238-14	3/8-24 x .75
X-6238-16	3/8-24 x 1.25
X-6238-21	3/8-24 x 4.00
X-6238-22	3/8-24 x 4.50
X-6024-5	7/16-14 x .75
X-6024-2	7/16-14 x 1.00
X-6024-8	7/16-14 x 1.25
X-6024-3	7/16-14 x 1.50
X-6024-4	7/16-14 x 2.00
X-6024-11	7/16-14 x 2.75
X-6024-12	7/16-14 x 6.50
X-129-15	1/2-13 x .75
X-129-17	1/2-13 x 1.00
X-129-18	1/2-13 x 1.25
X-129-19	1/2-13 x 1.50
X-129-20	1/2-13 x 1.75
X-129-21	1/2-13 x 2.00
X-129-22	1/2-13 x 2.25
X-129-23	1/2-13 x 2.50
X-129-24	1/2-13 x 2.75
X-129-25	1/2-13 x 3.00
X-129-27	1/2-13 x 3.50
X-129-29	1/2-13 x 4.00
X-129-30	1/2-13 x 4.50
X-463-9	1/2-13 x 5.50
X-129-44	1/2-13 x 6.00
X-129-51	1/2-20 x .75
X-129-45	1/2-20 x 1.25
X-129-52	1/2-20 x 1.50
X-6021-3	5/8-11 x 1.00
X-6021-4	5/8-11 x 1.25
X-6021-2	5/8-11 x 1.50
X-6021-1	5/8-11 x 1.75
273049	5/8-11 x 2.00
X-6021-5	5/8-11 x 2.25
X-6021-6	5/8-11 x 2.50
X-6021-7	5/8-11 x 2.75
X-6021-12	5/8-11 x 3.75
X-6021-11	5/8-11 x 4.50
X-6021-10	5/8-11 x 6.00
X-6021-9	5/8-18 x 2.50
X-6239-1	3/4-10 x 1.00
X-6239-8	3/4-10 x 1.25
X-6239-2	3/4-10 x 1.50
X-6239-3	3/4-10 x 2.00
X-6239-4	3/4-10 x 2.50
X-6239-5	3/4-10 x 3.00
X-6239-6	3/4-10 x 3.50
X-792-1	1-8 x 2.25
X-792-5	1-8 x 3.00
X-792-8	1-8 x 5.00

Part No. Dimensions Type

Hex Nuts

X-6009-1	1-8	Standard
X-6210-3	6-32	Whiz
X-6210-4	8-32	Whiz
X-6210-5	10-24	Whiz
X-6210-1	10-32	Whiz
X-6210-2	1/4-20	Spiralock
X-6210-6	1/4-28	Spiralock
X-6210-7	5/16-18	Spiralock
X-6210-8	5/16-24	Spiralock
X-6210-9	3/8-16	Spiralock
X-6210-10	3/8-24	Spiralock
X-6210-11	7/16-14	Spiralock
X-6210-12	1/2-13	Spiralock
X-6210-15	7/16-20	Spiralock
X-6210-14		Spiralock
X-85-3	5/8-11	Standard
X-88-12	3/4-10	Standard
X-89-2	1/2-20	Standard

Washers

Part No.	ID	OD	Thick.	Bolt/ Screw
X-25-46	.125	.250	.022	#4
X-25-9	.156	.375	.049	#6
X-25-48	.188	.438	.049	#8
X-25-36	.219	.500	.049	#10
X-25-40	.281	.625	.065	1/4
X-25-85	.344	.687	.065	5/16
X-25-37	.406	.812	.065	3/8
X-25-34	.469	.922	.065	7/16
X-25-26	.531	1.062	.095	1/2
X-25-15	.656	1.312	.095	5/8
X-25-29	.812	1.469	.134	3/4
X-25-127	1.062	2.000	.134	1

Metric

Hex head bolts are hardness grade 8.8 unless noted.

Part No.	Dimensions	Part No.	Dimensions	Part No.	Dimensions	Type		
Hex Head Bolts (partial thread)			Hex Head Bolts (full thread)			Hex Nuts		
M931-06040-60	M6-1.00 x 40	M933-04006-60	M4-0.70 x 6	M934-03-50	M3-0.50	Standard		
M931-06055-60	M6-1.00 x 55	M933-05050-60	M5-0.80 x 50	M934-04-50	M4-0.70	Standard		
M931-06060-60	M6-1.00 x 60	M933-06010-60	M6-1.00 x 10	M934-05-50	M5-0.80	Standard		
M931-06070-60	M6-1.00 x 70	M933-06014-60	M6-1.00 x 14	M982-05-80	M5-0.80	Elastic Stop		
M931-06075-60	M6-1.00 x 75	M933-06016-60	M6-1.00 x 16	M6923-06-80	M6-1.00	Spirallock		
M931-06090-60	M6-1.00 x 90	M933-06020-60	M6-1.00 x 20	M934-06-64	M6-1.00	Std. (green)		
M931-08035-60	M8-1.25 x 35	M933-06025-60	M6-1.00 x 25	M982-06-80	M6-1.00	Elastic Stop		
M931-08040-60	M8-1.25 x 40	M933-06040-60	M6-1.00 x 40	M6923-08-80	M8-1.25	Spirallock		
M931-08040-82	M8-1.25 x 40*	M933-06050-60	M6-1.00 x 50	M934-08-60	M8-1.25	Standard		
M931-08045-60	M8-1.25 x 45	M933-08016-60	M8-1.25 x 16	M982-08-80	M8-1.25	Elastic Stop		
M931-08050-60	M8-1.25 x 50	M933-08020-60	M8-1.25 x 20	M6923-10-80	M10-1.50	Spirallock		
M931-08055-82	M8-1.25 x 55*	M933-08025-60	M8-1.25 x 25	M982-10-80	M10-1.50	Elastic Stop		
M931-08060-60	M8-1.25 x 60	M933-08030-60	M8-1.25 x 30	M6923-12-80	M12-1.75	Spirallock		
M931-08070-60	M8-1.25 x 70	M933-10012-60	M10-1.50 x 12	M982-12-80	M12-1.75	Elastic Stop		
M931-08070-82	M8-1.25 x 70*	M961-10020-60	M10-1.25 x 20	M982-14-80	M14-2.00	Elastic Stop		
M931-08075-60	M8-1.25 x 75	M933-10020-60	M10-1.50 x 20	M6923-16-80	M16-2.00	Spirallock		
M931-08080-60	M8-1.25 x 80	M933-10025-60	M10-1.50 x 25	M982-16-80	M16-2.00	Elastic Stop		
M931-08090-60	M8-1.25 x 90	M933-10030-60	M10-1.50 x 30	M982-18-80	M18-2.50	Elastic Stop		
M931-08095-60	M8-1.25 x 95	M933-10030-82	M10-1.50 x 30*	M934-20-80	M20-2.50	Standard		
M931-08100-60	M8-1.25 x 100	M961-10035-60	M10-1.25 x 35	M982-20-80	M20-2.50	Elastic Stop		
M931-10040-60	M10-1.50 x 40	M933-10035-60	M10-1.50 x 35	M934-22-80	M22-2.50	Standard		
M931-10045-60	M10-1.50 x 45	M933-12016-60	M12-1.75 x 16	M982-22-80	M22-2.50	Elastic Stop		
M931-10050-60	M10-1.50 x 50	M933-12020-60	M12-1.75 x 20	M934-24-80	M24-3.00	Standard		
M931-10055-60	M10-1.50 x 55	M933-12025-60	M12-1.75 x 25	M982-24-80	M24-3.00	Elastic Stop		
M931-10060-60	M10-1.50 x 60	M933-12025-82	M12-1.75 x 25*	Washers				
M931-10065-60	M10-1.50 x 65	M933-12025-82	M12-1.75 x 25*	Part No.	ID	OD	Bolt/ Thick. Screw	
M931-10070-60	M10-1.50 x 70	M933-12030-60	M12-1.75 x 30	M125A-03-80	3.2	7.0	0.5 M3	
M931-10080-60	M10-1.50 x 80	M933-12040-60	M12-1.75 x 40	M125A-04-80	4.3	9.0	0.8 M4	
M931-10090-60	M10-1.50 x 90	M933-12040-82	M12-1.75 x 40*	M125A-05-80	5.3	10.0	1.0 M5	
M931-10100-60	M10-1.50 x 100	M961-14025-60	M14-1.50 x 25	M125A-06-80	6.4	12.0	1.6 M6	
M931-12045-60	M12-1.75 x 45	M933-14025-60	M14-2.00 x 25	M125A-08-80	8.4	16.0	1.6 M8	
M931-12050-60	M12-1.75 x 50	M961-16025-60	M16-1.50 x 25	M125A-10-80	10.5	20.0	2.0 M10	
M931-12055-60	M12-1.75 x 55	M933-16025-60	M16-2.00 x 25	M125A-12-80	13.0	24.0	2.5 M12	
M931-12060-60	M12-1.75 x 60	M933-16030-82	M16-2.00 x 30*	M125A-14-80	15.0	28.0	2.5 M14	
M931-12065-60	M12-1.75 x 65	M933-16035-60	M16-2.00 x 35	M125A-16-80	17.0	30.0	3.0 M16	
M931-12080-60	M12-1.75 x 80	M933-16040-60	M16-2.00 x 40	M125A-18-80	19.0	34.0	3.0 M18	
M931-12090-60	M12-1.75 x 90	M933-16050-60	M16-2.00 x 50	M125A-20-80	21.0	37.0	3.0 M20	
M931-12100-60	M12-1.75 x 100	M933-16050-82	M16-2.00 x 50*	M125A-24-80	25.0	44.0	4.0 M24	
M931-12110-60	M12-1.75 x 110	M933-16060-60	M16-2.00 x 60	Pan Head Machine Screws				
M931-16090-60	M16-2.00 x 90	M933-18050-60	M18-2.50 x 50	M7985A-03010-20	M3-0.50 x 10			
M931-20065-60	M20-2.50 x 65	M933-18060-60	M18-2.50 x 60	M7985A-03012-20	M3-0.50 x 12			
M931-20120-60	M20-2.50 x 120	Flat Head Machine Screws						
M931-20160-60	M20-2.50 x 160	M965A-05016-20	M5-0.80 x 16					
M931-22090-60	M22-2.50 x 90							
M931-22120-60	M22-2.50 x 120							
M931-22160-60	M22-2.50 x 160							
M931-24090-60	M24-3.00 x 90							
M931-24120-60	M24-3.00 x 120							
M931-24160-60	M24-3.00 x 160							

* This metric hex bolt's hardness is grade 10.9.

TP-5833 8/99a

© Kohler Co., 1997, 1999. All rights reserved.

KOHLER[®] POWER SYSTEMS

KOHLER CO. Kohler, Wisconsin 53044
Phone 920-565-3381, Web site www.kohlergenerators.com
Fax 920-459-1646 (U.S.A. Sales), Fax 920-459-1614 (International)
For the nearest sales and service outlet in U.S.A. and Canada
Phone 1-800-544-2444