



# INSTRUCTIONS

-J03643

REV. 2010-09-30

## FL ADJUSTABLE RIDER BACKREST MOUNTING KIT

### GENERAL

#### Kit Number

54099-10

#### Models

For model fitment information, see the P&A Retail Catalog or the Parts and Accessories section of [www.harley-davidson.com](http://www.harley-davidson.com) (English only).

#### Additional Parts Required

Separate purchase of a FL Adjustable Rider Backrest Kit is required for installation of this kit. See a Harley-Davidson Dealer.

### ⚠ WARNING

The rider's safety depends upon the correct installation of this kit. If the procedure is not within your capabilities or you do not have the correct tools, have a Harley-Davidson dealer perform the installation. Improper installation of this kit could result in death or serious injury. (00308a)

#### NOTE

This instruction sheet references service manual information. A service manual for your model motorcycle is required for this installation and is available from a Harley-Davidson Dealer.

#### Kit Contents

See Figure 9 and Table 1.

### REMOVAL

1. Remove existing seat and grab strap (if equipped) following instructions in the service manual.
2. Refer to the service manual and remove the left side cover and battery.
3. See Figure 5. Pull plastic spark plug wire clip out of the hole in the frame plate at the location where the adjustment handle bracket is going to mount. Discard plastic hose clip.
4. Remove the mid-frame air deflector upper left mounting bolt and washer. Save for installation.
5. **If equipped with a grab rail:** See Figure 1. Remove grab rail screws (1) and discard.
6. Remove wire harness retention clip located above the bank angle sensor. Discard clip.
7. Remove screws (3) holding the bank angle sensor (4).

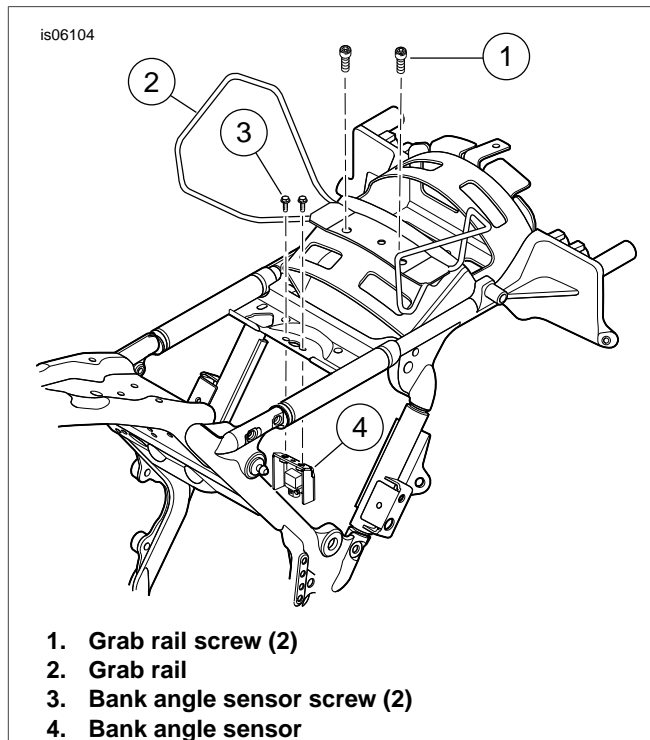

Figure 1. Remove Bank Angle Sensor Screws

### INSTALLATION

1. See Figure 2. Install clip nut (1) in mounting hole (2). Align the clip nut hole with alignment hole (3).  
Follow the instructions included with the Mid-Frame Air Deflector Kit to install the four self-clinching special nuts.
2. Move the electrical connector so that the backrest mounting base does not interfere with it.
3. See Figure 3. Install mounting bracket (8) to mounting base (4) with screw (6) and flange nut (7). Tighten screw to 72-96 **in-lbs** (8-11 Nm).

#### NOTE

Only use the specified screw to install the mounting bracket to the bank angle sensor.

4. Secure the mounting bracket (8) to the bank angle sensor bracket with 1/4-20 x 5/8 inch screws (5).
5. If installing grab strap (9), install backrest mounting base and grab strap with screws (1) and washers (2).  
If grab rail is installed, install backrest mounting base with screws (1) and washers (2).

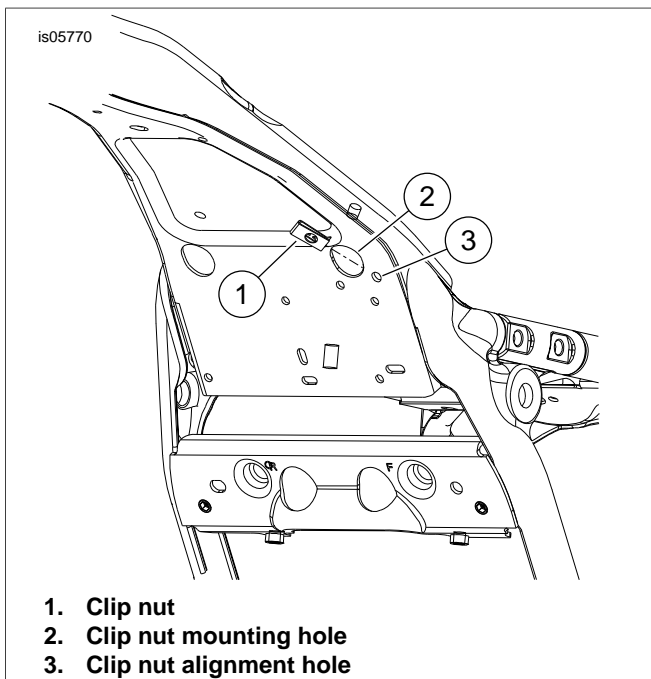

Figure 2. Install Clip Nut

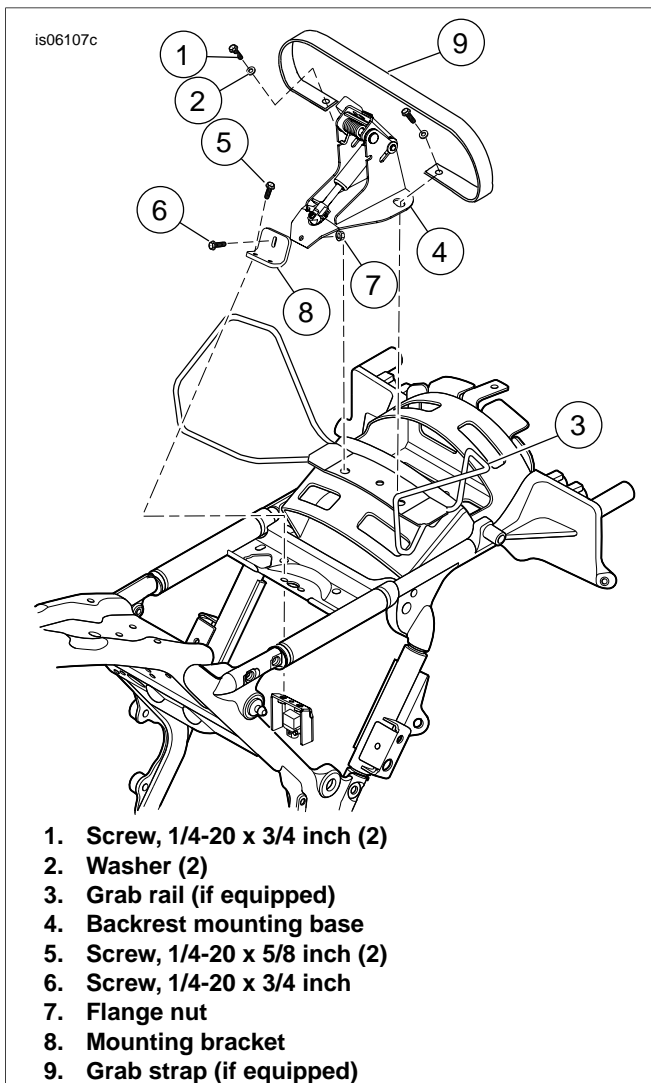

Figure 3. Install Backrest Mounting Base

6. Tighten rear mounting screws (1) to 60-96 **in-lbs** (7-11 Nm).
7. Tighten front mounting screws (5) to 72-108 **in-lbs** (8-12 Nm).
8. See Figure 9. Mount actuator handle with cable (13) to actuator handle bracket (12) with screws (9) and locknuts (11).
9. See Figure 5. Verify that the backrest adjustment cable is not connected to the mounting bracket. Starting at the actuator assembly end, route the backrest cable under the cross-member plate and up through the frame (5).
10. Continue routing cable between the battery compartment and the fuse/electrical box. Continue routing the cable up from the rear of the electrical box to between the frame and the rear fender, and up to the top of the rear fender and to the backrest bracket.

#### NOTES

*Do not use Loctite on the fasteners used to secure the mid-frame air deflector to the frame. If Loctite contacts the air deflector, damage will occur.*

11. See Figure 5. Slide the flat side of the actuator assembly (4) bracket behind the wires and align the deflector upper mounting hole with slot in adjustment handle bracket. Make sure the hook/bent tab of the bracket engages the edge of the cross-member plate. When aligned, insert and tighten screw and washer to 25-35 **in-lbs** (2.8-3.9 Nm).
12. See Figure 9. Obtain the adhesive-backed clip (8) from kit. Clean the flat area of the adjustment handle bracket approximately in the location where the spark plug wire stock clip was removed using isopropyl alcohol. Attach the clip to the bracket and route the spark plug wire and evaporator tube (if equipped) through the clip. Fold clip down to capture the wire and/or tube securely.
13. See Figure 6. Attach the release cable (1) to the backrest mounting base (2) as shown. Carefully secure the cable to the shaft of the gas spring (4) with the provided cable strap (3). Do not over-tighten the cable strap.
14. Refer to the service manual and install battery and left side cover.

## SEAT PROTECTOR INSTALLATION

1. Temporarily install the seat over the backrest mechanism.
2. Install but do not tighten the seat mounting hardware.
3. Install the rider backrest following the instructions under BACKREST INSTALLATION.
4. See Figure 9. Obtain seat protector (17).
5. Apply masking tape to seat protector as an aid to locate the protector in the seat.
  - a. Apply masking tape to the smooth, non-adhesive side of the seat protector.
  - b. Masking tape should extend 2 in (5.1 cm) past each edge of the shorter side of the seat protector.
6. Insert the seat protector from above between the rear of the seat opening and the backrest mechanism all the way to the edge with the tape. Do not tape protector to seat at this time.

- See Figure 8. With the backrest and seat in place, push the backrest to the fully forward position (3). The backrest mechanism will press against the underside of the seat and against the inserted seat protector.

**NOTE**

*The purpose of the seat protector is to prevent premature wear between the backrest mechanism and the underside of the seat. If the seat protector is placed too low in the seat opening, the backrest mechanism, when pushed forward, may snag the upper edge of the protector and be difficult to return upright.*

- With backrest mechanism fully forward, adjust the seat protector so the upper-most edge is positioned roughly 1/2 inch (13 mm) above the rear edge of the mechanism within the seat pocket.
- Temporarily adhere the masking tape to the seat to retain the determined position.
- Keeping the seat protector taped in place, remove seat and place upside down on a smooth, clean surface.
- Mark or otherwise indicate the location of the edges of the seat protector on the underside of the seat.
- Remove the protector from the seat and the masking tape from the protector.

**NOTE**

*To keep the inserted backrest from snagging the protector when the backrest is being installed, slightly roll the top-most edge of the seat protector that will be nearest the pillion portion of the seat.*

- See Figure 4. Take note of the shape of the surface the seat protector (2) will cover and gently shape the protector to better fit the seat contours (1).
- Note the location of the seat protector and clean a roughly four inch square area with soapy water or alcohol.
- Remove adhesive liner from seat protector and place the seat protector over the intended location.
- Press from middle of seat protector outward to remove air bubbles trapped between protector and seat.
- Allow 24 hours for adhesive to fully cure before getting wet or placing in extreme temperatures.

## SEAT INSTALLATION

**⚠ WARNING**

**After installing seat, pull upward on seat to be sure it is locked in position. While riding, a loose seat can shift causing loss of control, which could result in death or serious injury. (00070b)**

- If grab strap is installed, slide seat through grab strap and install seat with previously removed hardware following the instructions in the service manual.
- If the grab rail is installed, install seat with the previously removed hardware following the instructions in the service manual.

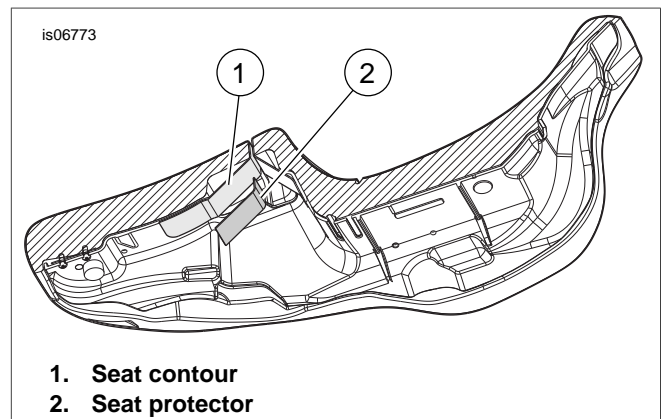

**Figure 4. Underside of Seat**

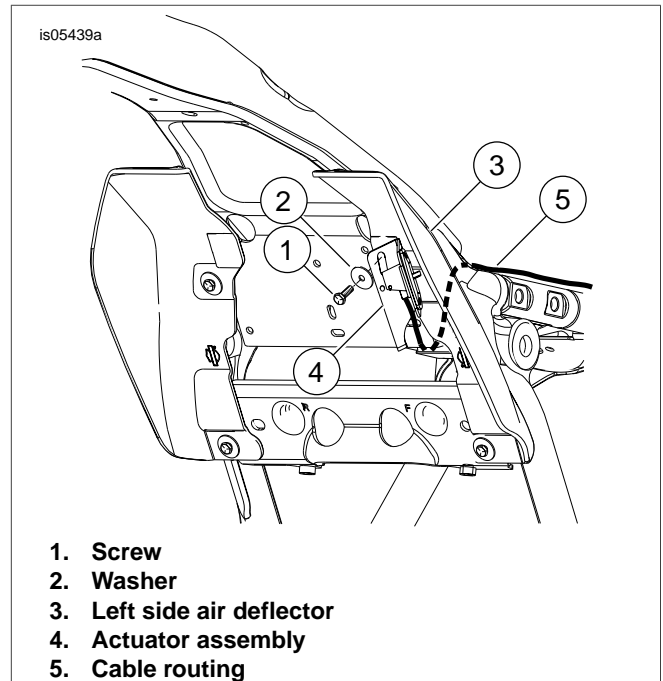

**Figure 5. Installing Actuator Assembly with Mid-Frame Air Deflector**

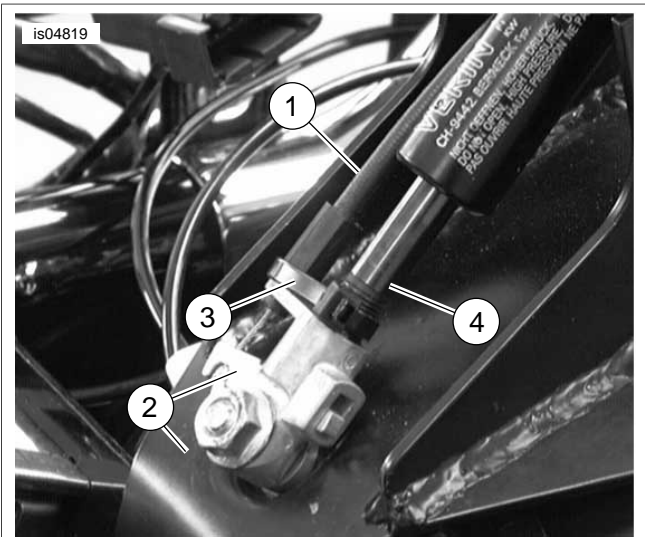

1. Release cable
2. Backrest mounting base
3. Cable strap
4. Gas spring shaft

Figure 6. Attach Cable to Backrest Mounting Base

## BACKREST INSTALLATION

See Figure 7. Press on lever located on backrest bracket as shown. Insert backrest and press gently until it snaps into place.

### WARNING

After installing backrest, pull upward to be sure it is locked in position. While riding, a loose backrest can shift causing loss of control, which could result in death or serious injury. (00386a)

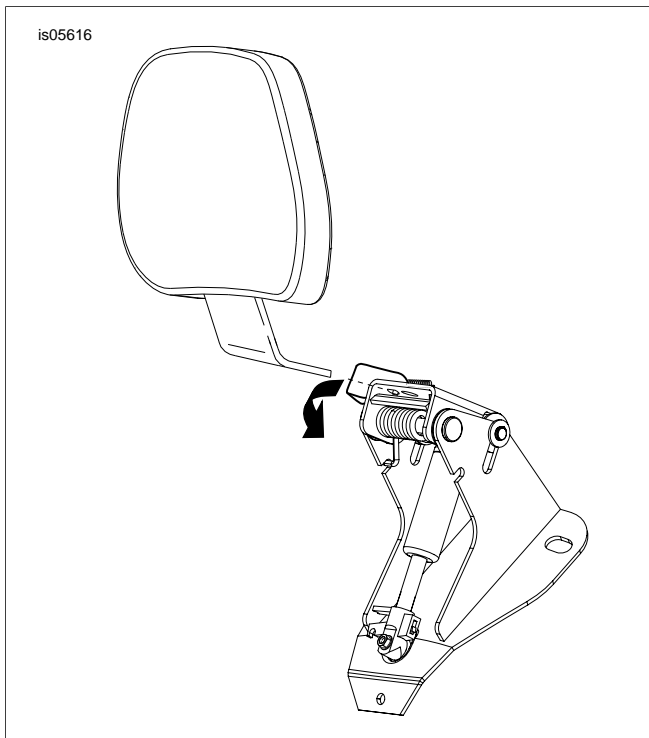

Figure 7. Installing Backrest

## OPERATION

### WARNING

After installing backrest, pull upward to be sure it is locked in position. While riding, a loose backrest can shift causing loss of control, which could result in death or serious injury. (00386a)

1. See Figure 8. The adjustment handle is used to move the backrest pad into the forward and rearward positions.
2. To adjust the backrest pad forward or rearward (2), push the handle. Leaning back against the backrest pad will help adjust it rearward. Keeping your weight off of the backrest pad while pushing on the handle will cause the backrest to come to its full forward position. Releasing the handle will lock the backrest into place.
3. To adjust the backrest pad up and down (1), pull the knob on rear of pad. Move the backrest up or down into the desired position then release when the pad is in the desired position.

### NOTE

Be careful when pushing the seat to the full forward mounting position (3). Pushing the seat forward too far could tear the seat material.

4. The backrest pad may be pushed forward against seat (3) as shown to ease in getting off and on the motorcycle without activating the release handle.

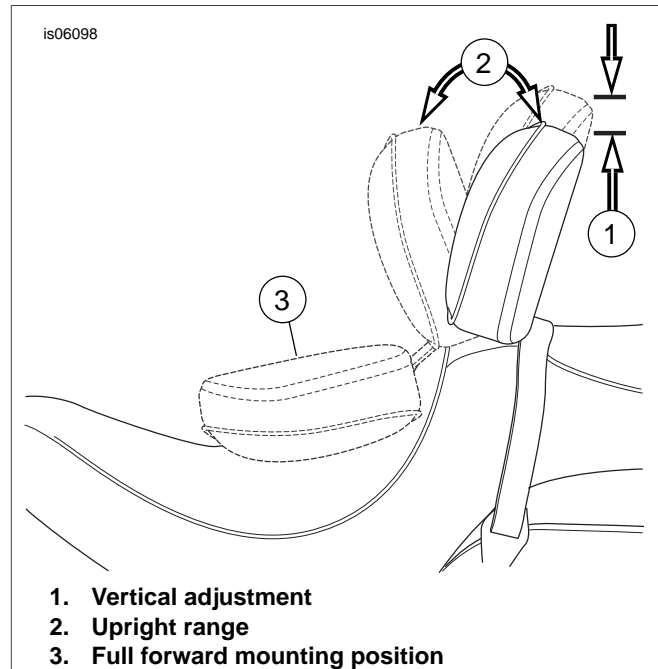

1. Vertical adjustment
2. Upright range
3. Full forward mounting position

Figure 8. Backrest Postions

## SERVICE PARTS

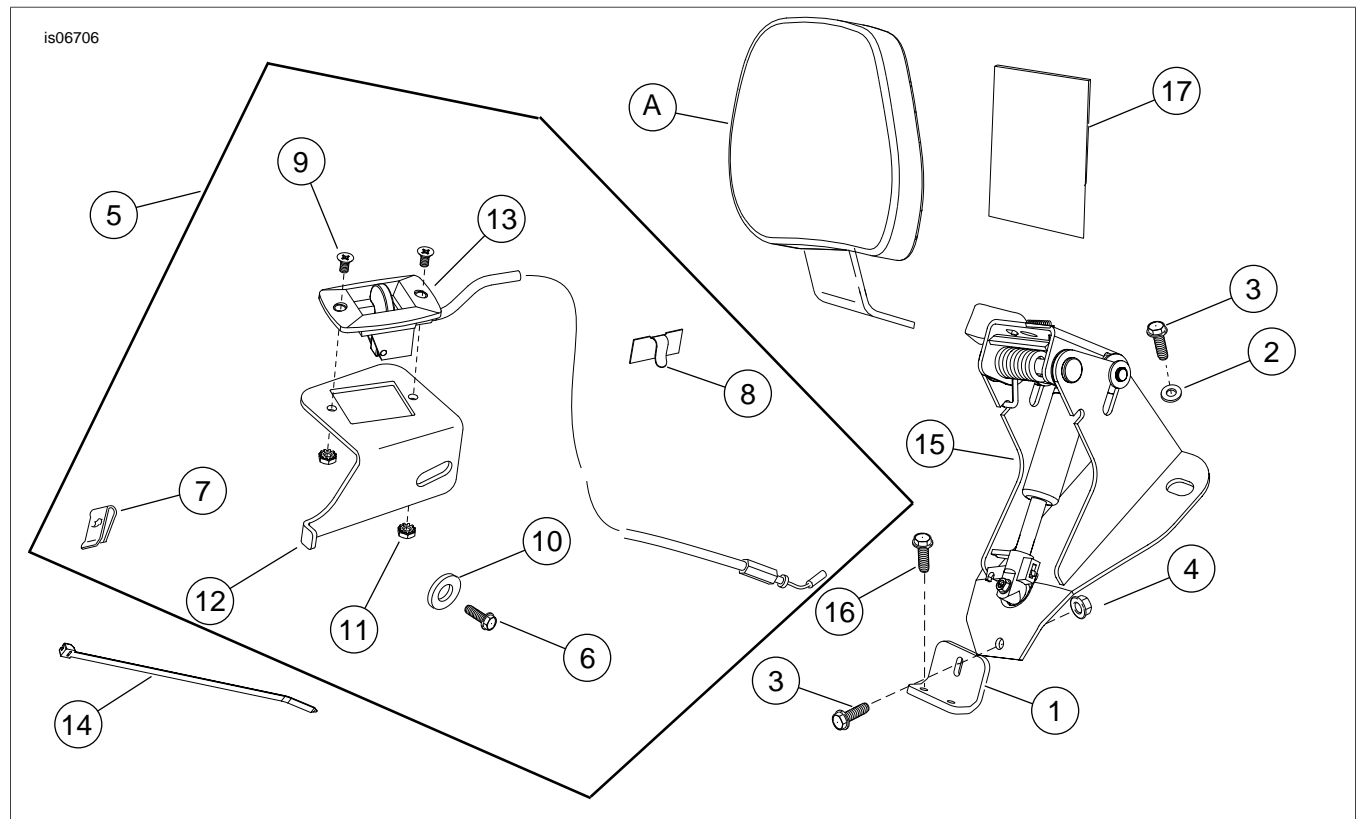

**Figure 9. Service Parts: FL Adjustable Rider Backrest Mounting Hardware Kit**

**Table 1. Service Parts Table: Adjustable Rider Backrest**

| Item  | Description (Quantity)  | Part Number         |
|---|---|---------------------|
| 1   | Mounting bracket  | 83990-10            |
| 2   | Washer (2)  | 6223                |
| 3   | Screw, 1/4-20 x 3/4 inch (3)  | 3574                |
| 4   | Nut, locking flange, 1/4-20   | 7716                |
| 5   | Actuation handle kit (includes Items 6 through 13)                            | 52365-09            |
| 6   | • Screw, 1/4-20 x 3/4 inch  | 3574                |
| 7   | • Clip nut  | 8108                |
| 8   | • Wire guide  | 10102               |
| 9   | • Screw (2)   | 2933                |
| 10  | • Washer  | 6036                |
| 11  | • Lock nut (2)  | 7838                |
| 12  | • Bracket   | Not Sold Separately |
| 13  | • Actuator handle with cable  | Not Sold Separately |
| 14  | Cable strap   | Not Sold Separately |
| 15  | Backrest mounting base  | Not Sold Separately |
| 16  | Screw, flange, 1/4-20 x 5/8 inch (2)  | Not Sold Separately |
| 17  | Seat protector, adhesive backed, 3 1/2 x 3 inch                               | 52300017            |
| <b>Items referenced in text, but not included in kit:</b> |   |                     |
| A   | Backrest pad  | Sold Separately     |
| B   | Pivot bracket repair kit (includes pivot bracket, lever, spring and hardware) | 52342-09            |