

**NORTH STAR ENGINEERED PRODUCTS**

**OPERATION AND SERVICE MANUAL**

**FOR THE**

**FP-95**

**FOOD PROCESSING CENTRIFUGE**



*TEST & INSPECTION SHEET*

SOLD TO \_\_\_\_\_

***MACHINE***

\_\_\_\_\_ MODEL \_\_\_\_\_ NSEP ORDER #

\_\_\_\_\_ SERIAL NUMBER \_\_\_\_\_ DATE

***MOTOR & CONTROLS***

\_\_\_\_\_ INVERTER S/N

\_\_\_\_\_ MOTOR VOLTAGE \_\_\_\_\_ CONTROL VOLTAGE

\_\_\_\_\_ MOTOR MFG \_\_\_\_\_ INCOMING POWER

\_\_\_\_\_ MOTOR S/N \_\_\_\_\_ MOTOR HORSEPOWER

\_\_\_\_\_ MOTOR RPM \_\_\_\_\_ MOTOR PULLEY SIZE

\_\_\_\_\_ MOTOR CODE NO. \_\_\_\_\_ DRIVE BELT

***DRIVE UNIT AND BASKET***

\_\_\_\_\_ UNIT PULLEY SIZE

\_\_\_\_\_ BASKET RPM (MAXIMUM)

\_\_\_\_\_ BASKET WEIGHT CAPACITY

***TESTING RESULTS***

\_\_\_\_\_ PROCEDURE NUMBER USED

\_\_\_\_\_ STARTING AMPS

\_\_\_\_\_ RUNNING AMPS

\_\_\_\_\_ BRAKING TIME

\_\_\_\_\_ INSPECTORS INITIALS

NORTH STAR ENGINEERED PRODUCTS  
28905 GLENWOOD ROAD.  
TOLEDO, OHIO 43611

FORM Z-00860

REV B 4/7/06

# TEST & INSPECTION SHEET

SOLD TO \_\_\_\_\_

## **MACHINE**

\_\_\_\_\_ MODEL \_\_\_\_\_ NSEP ORDER #

\_\_\_\_\_ SERIAL NUMBER \_\_\_\_\_ DATE

## **MOTOR & CONTROLS**

\_\_\_\_\_ INVERTER S/N

\_\_\_\_\_ MOTOR VOLTAGE \_\_\_\_\_ CONTROL VOLTAGE

\_\_\_\_\_ MOTOR MFG \_\_\_\_\_ INCOMING POWER

\_\_\_\_\_ MOTOR S/N \_\_\_\_\_ MOTOR HORSEPOWER

\_\_\_\_\_ MOTOR RPM \_\_\_\_\_ MOTOR PULLEY SIZE

\_\_\_\_\_ MOTOR CODE NO. \_\_\_\_\_ DRIVE BELT

## **DRIVE UNIT AND BASKET**

\_\_\_\_\_ UNIT PULLEY SIZE

\_\_\_\_\_ BASKET RPM (MAXIMUM)

\_\_\_\_\_ BASKET WEIGHT CAPACITY

## **TESTING RESULTS**

\_\_\_\_\_ PROCEDURE NUMBER USED

\_\_\_\_\_ STARTING AMPS

\_\_\_\_\_ RUNNING AMPS

\_\_\_\_\_ BRAKING TIME

\_\_\_\_\_ INSPECTORS INITIALS

NORTH STAR ENGINEERED PRODUCTS  
28905 GLENWOOD ROAD  
PERRYSBURG, OH 43551  
00860 REV B 4/5/06

FORM Z-

TEST RESULTS #4

205TX, 305TX, 605TX, 805TX, FP305, FP605, FP805, FP90, FP-95, FP900, GP-100, & GP-130 CENTRIFUGES

S.O. # \_\_\_\_\_

CUSTOMER \_\_\_\_\_

SERIAL # \_\_\_\_\_

1. CYCLE TEST MACHINE 15 TIMES WITH BASKET AT MAXIMUM LOAD; INCLUSIVE SAFETY EVALUATION. CHECKED BY: \_\_\_\_\_

2. FILL BASKET WITH WATER AND CHECK FOR SEAM AND LID LEAKS. CHECKED BY: \_\_\_\_\_

3. RECORD CYCLE TIME FOR 3 OF THE 15 TEST CYCLES.

\_\_\_\_\_ MINS. & \_\_\_\_\_ SEC.

\_\_\_\_\_ MINS. & \_\_\_\_\_ SEC.

\_\_\_\_\_ MINS. & \_\_\_\_\_ SEC.

4. WELD COSMETICS CHECKED BY: \_\_\_\_\_

5. VIBRATION TEST CONTROL BOX-SIDE \_\_\_\_\_ IN./SEC.

CONTROL BOX-TOP \_\_\_\_\_ IN./SEC.

6. WEIGHT CAPACITY ETCHED ON BASKET. \_\_\_\_\_ LB.

7. SERIAL # OF FP90 BASKET(S) \_\_\_\_\_

# OF DOLLIES \_\_\_\_\_

# OF YOKES \_\_\_\_\_

8. COMMENTS ON MACHINE AND OPTIONS: \_\_\_\_\_

9. INSPECTOR'S NAME: \_\_\_\_\_

TEST RESULTS #4

205TX, 305TX, 605TX, 805TX, FP305, FP605, FP805, FP90, FP-95, FP900, GP-100, & GP-130 CENTRIFUGES

S.O. # \_\_\_\_\_

CUSTOMER \_\_\_\_\_

SERIAL # \_\_\_\_\_

1. CYCLE TEST MACHINE 15 TIMES WITH BASKET AT MAXIMUM LOAD; INCLUSIVE SAFETY EVALUATION. CHECKED BY: \_\_\_\_\_

2. FILL BASKET WITH WATER AND CHECK FOR SEAM AND LID LEAKS. CHECKED BY: \_\_\_\_\_

3. RECORD CYCLE TIME FOR 3 OF THE 15 TEST CYCLES.

\_\_\_\_\_ MINS. & \_\_\_\_\_ SEC.

\_\_\_\_\_ MINS. & \_\_\_\_\_ SEC.

\_\_\_\_\_ MINS. & \_\_\_\_\_ SEC.

4. WELD COSMETICS CHECKED BY: \_\_\_\_\_

5. VIBRATION TEST CONTROL BOX-SIDE \_\_\_\_\_ IN./SEC.

CONTROL BOX-TOP \_\_\_\_\_ IN./SEC.

6. WEIGHT CAPACITY ETCHED ON BASKET. \_\_\_\_\_ LB.

7. SERIAL # OF FP90 BASKET(S) \_\_\_\_\_

# OF DOLLIES \_\_\_\_\_

# OF YOKES \_\_\_\_\_

8. COMMENTS ON MACHINE AND OPTIONS: \_\_\_\_\_

\_\_\_\_\_

9. INSPECTOR'S NAME: \_\_\_\_\_

## TABLE OF CONTENTS

THREE IMPORTANT POINTS .....	7
PREPARATION FOR USE AND INSTALLATION INSTRUCTIONS .....	8
I. UNPACKING INSTRUCTIONS: .....	8
II. PREPARING YOUR MACHINE FOR INSTALLATION:.....	8
III. INSTALLATION:.....	8
MOUNTING PRECAUTIONS.....	9
IV. SAFETY SYSTEM TEST:.....	10
INTERCONNECTION DIAGRAM .....	11
SPECIFICATIONS .....	12
OPERATING INSTRUCTIONS.....	13
A. DESCRIPTION OF CONTROLS : .....	13
B. LOADING PRODUCT :.....	13
C. OPERATION:.....	14
D. OPERATION ,OF SAFETIES:.....	14
SEQUENCE OF OPERATION .....	15
I. STARTING SEQUENCE:.....	15
II. STOPPING SEQUENCE:.....	15
SERVICE MANUAL.....	16
SERVICE MANUAL TABLE OF CONTENTS .....	17
MAINTENANCE AND SERVICE NOTICE .....	24
TROUBLE SHOOTING GUIDE	
MODEL FP-95 .....	24
SCHEDULED MAINTENANCE PROGRAM	
MODEL FP-95 .....	27
I. WEEKLY LUBRICATION PROCEDURE.....	27
II. MONTHLY PROCEDURES.....	27
III. SEMIANNUAL PROCEDURES .....	28
INVERTER INITIALIZATION PROCEDURE	
TO PROGRAM ANY VARIABLE (G5 INVERTER).....	29
FOR FIRST TIME START UP (G5 INVERTER).....	29
TO ADJUST SPEED ONLY (G5 INVERTER) .....	31
CALCULATING FREQUENCY FOR A DESIRED SPEED: (G5 INVERTER).....	31
TO PROGRAM ANY VARIABLE (ACS400 INVERTER) .....	32
FOR FIRST TIME START UP (ACS400 INVERTER).....	32
TO ADJUST SPEED ONLY (ACS400 INVERTER).....	33
CALCULATING FREQUENCY FOR A DESIRED SPEED: (ACS400 INVERTER) ...	33
FOR FIRST TIME START UP (ACS550 INVERTER).....	34
TO ADJUST SPEED ONLY (ACS550 INVERTER).....	35
CALCULATING FREQUENCY FOR A DESIRED SPEED: (ACS550 INVERTER) ...	35
GLOSSARY .....	36
DIRECT DRIVE UNIT ASSEMBLY.....	37
SCHEMATIC DIAGRAM (G5 INVERTER).....	38
REMOTE PANEL WIRING DIAGRAM (G5 INVERTER).....	39
SCHEMATIC DIAGRAM (ACS400 INVERTER).....	40
REMOTE PANEL WIRING DIAGRAM (ACS400 INVERTER).....	41
REMOTE PANEL SCHEMATIC DIAGRAM (ACS550 INVERTER).....	42
MACHINE PANEL WIRING DIAGRAM.....	43
MACHINE PANEL PIPING DIAGRAM.....	44
PARTS LIST .....	45
RECOMMENDED SPARE PARTS .....	48
WARRANTY INFORMATION .....	INSIDE REAR COVER

## **THREE IMPORTANT POINTS**

1. REMOVE ALL SUPPORTS FROM (UNDER AND AROUND) THE BASKET BEFORE STARTING THE MACHINE. WHEN REPLACING THE BASKET INTO THE MACHINE, SET IT GENTLY DOWN ON THE SHAFT AND ROTATE THE BASKET UNTIL IT DROPS AND SEATS ONTO THE BASKET BALL. AN IMPROPERLY INSTALLED BASKET CAN RESULT IN DAMAGE TO THE CENTER POST AND OR THE BASKET BALL.
2. DO NOT RESTRICT OR REDUCE DRAIN IN ANY WAY. DO NOT CONNECT THE MACHINE ONTO THE SAME DRAIN LINE AS OTHER EQUIPMENT. FAILURE TO ADHERE TO THE FOREGOING MAY RESULT IN A BACK WASH.
3. IT IS ESSENTIAL TO MAINTAIN ALL SAFETY SYSTEMS. FAILURE TO ADHERE TO THE SAFETY MAINTENANCE STANDARDS MAY VOID THE WARRANTY OF THIS MACHINE.

# **PREPARATION FOR USE AND INSTALLATION INSTRUCTIONS**

## **MODEL FP-95**

### **I. UNPACKING INSTRUCTIONS:**

- A. INSPECT your packaged machine for shipping damage. Look for holes or tears in the packaging materials and any other outward signs of damage. REPORT ALL DAMAGE TO THE TRANSPORTATION COMPANY IMMEDIATELY.
- B. Remove packaging from around your machine.
- C. OPEN THE LID of your centrifuge.
- D. REMOVE THE BASKET from your centrifuge.
- E. REMOVE the corrugated spacers from the interior of the machine.
- F. INSPECT the interior of your machine for any signs of damage.
- G. REINSTALL THE BASKET into your centrifuge.

### **II. PREPARING YOUR MACHINE FOR INSTALLATION:**

- A. MOVE MACHINE on pallet to desired location.
- B. REMOVE MACHINE FROM PALLET by removing the bolts through the feet of the machine and sliding the machine off the pallet.
- C. INSPECT the exterior of the machine for shipping damage. Look for dents or scratches in lid, curb assembly, skirt, or control box. REPORT ALL DAMAGE TO TRUCKING COMPANY IMMEDIATELY.

### **III. INSTALLATION:**

- A. MOUNTING:
  - 1. MARK HOLES on floor by moving the machine into place and marking the hole locations through the holes in the legs. Make sure to allow adequate space behind the machine for servicing the rear control panel.
  - 2. DRILL MOUNTING HOLES. Use 2-1/2" X 1/2" lag bolts into lead anchors into a concrete floor. (Mounting hardware is not included.)
  - 3. BOLT machine into place. Do not tighten bolts.
  - 4. LEVEL MACHINE. Use metal shims under legs if necessary.
  - 5. TIGHTEN all mounting bolts.



## **MOUNTING PRECAUTIONS**

- \* NEVER USE RESILIENT PADS UNDER LEGS.
- \* MOUNT MACHINE ON LEVEL SURFACE.
- \* CHECK BOLTS PERIODICALLY FOR TIGHTNESS.

### **B. INSTALLING THE DRAIN:**

1. The drain should pitch at least one inch per foot for proper flow.
2. The drain's flow should not be restricted or reduced.
3. The drain should dump into an open sump or be vented to prevent water backup.

### **C. PNEUMATIC CONNECTION:**

1. Connect the air supply (80-100 PSI) for the centrifuge to the regulator on the side of the control box.

### **D. ELECTRICAL CONNECTION:**

1. INSPECT the data plate on the machine to confirm the required input voltage and amperage.
2. DISCONNECT BOX: The centrifuge should be connected to its own electrical disconnect box, which should be remotely mounted. DO NOT mount the disconnect box on or next to the machine. For proper fusing see SPECIFICATIONS on page 9.
3. NATIONAL ELECTRICAL CODE: All wiring, motor and circuit disconnecting devices must be installed in conformance with the National Electrical Code and applicable local codes.
4. CONNECTION OF CENTRIFUGE:
  - a. Wire the remote box to the machine panel per the wiring diagram. (Seven control wires plus power & ground for the motor.) Motor wires must be run in separate conduit.
  - b. Place the MAN AUTO switch in the MAN position. Turn on incoming power.
  - c. Test the operation of your centrifuge by closing the lid and starting the machine. Set the timer to 3 minutes. Pull the STOP button out, and push the start button.

#### **IV. SAFETY SYSTEM TEST:**

- A. Make sure that the back panel is securely fastened to the control box.
- B. START THE MACHINE:
  - 1. Lighted START button must be lit.
  - 2. Lid should be firmly locked and closed.
- C. PUSH BUTTON TO STOP THE MACHINE:
  - 1. Machine should stop in 60 seconds.
  - 2. "START" light should go out, the lid lock will release, and the lid will open automatically. (See section 'K' of the service manual for adjustment procedures).
- D. RE- START MACHINE:
  - 1. Close lid and push start button. If the timer has timed out, the lid must open then close to allow the machine to be restarted.
  - 2. "START" light should be on.
  - 3. The machine should re-start and run through its complete cycle. The machine should stop within 60 seconds of the end of its cycle.
  - 4. "START" light should go out after the machine has stopped.
  - 5. Lid will unlock automatically at the end of the cycle.
  - 6. The basket should not be spinning when the lid is opened.
- E. LID OPEN TEST:
  - 1. With the lid open, attempt to start the machine by pushing the start button.
  - 2. The machine should not start with the lid open.
  - 3. "START" light should NOT be on.

**IF THE SAFETY SYSTEM IS NOT WORKING PROPERLY, TAKE THE CENTRIFUGE OUT OF SERVICE IMMEDIATELY.**

**CONSULT THE FACTORY AT (419) 726-2645 FOR ASSISTANCE WITH CORRECTING ANY SAFETY ISSUES.**

**INTERCONNECTION DIAGRAM**  
**REMOTE OPERATORS PANEL TO MACHINE CONTROL PANEL**

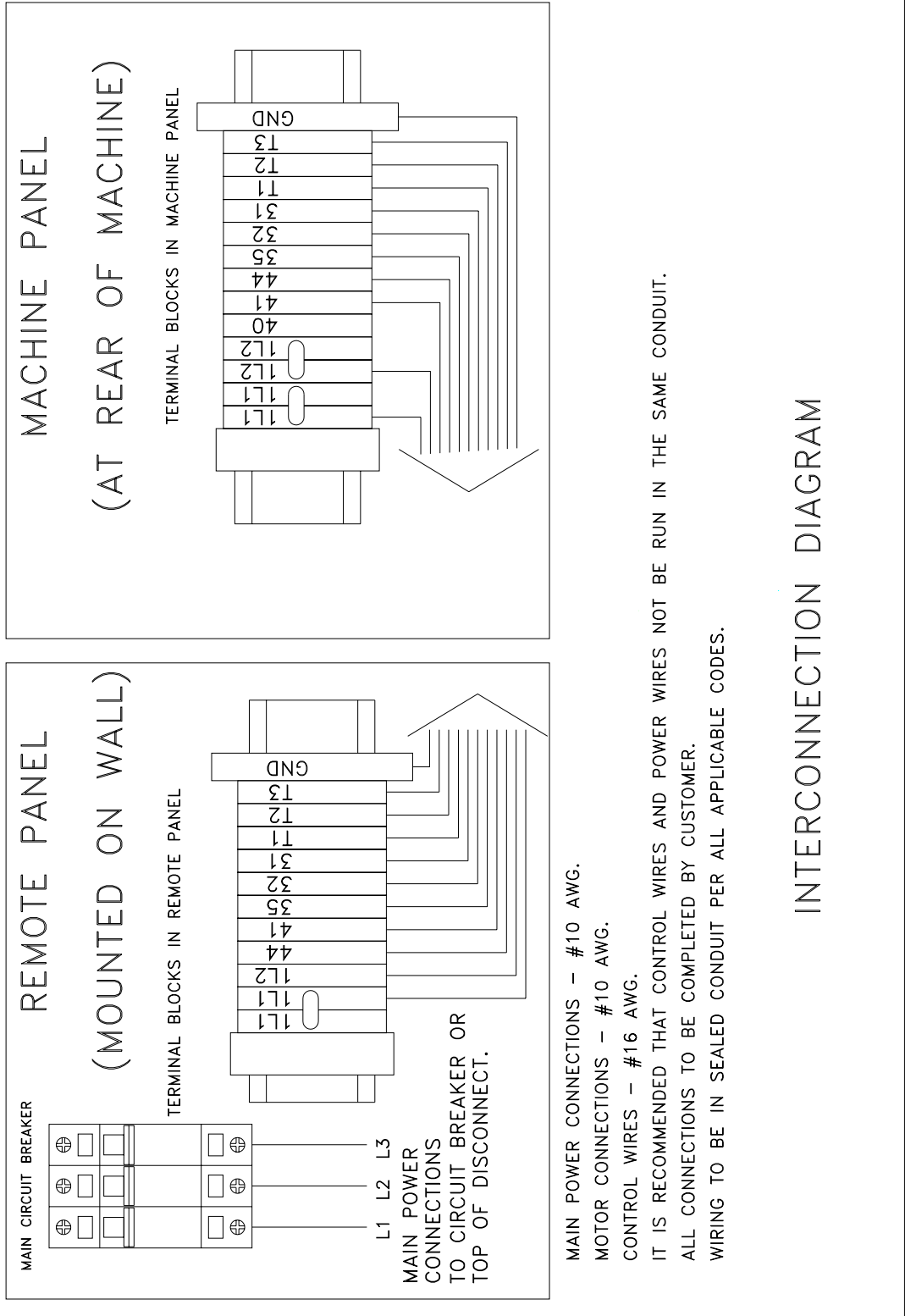

## SPECIFICATIONS

### SPECIFICATIONS

### MODEL FP95

BASKET CAPACITY	130 POUNDS
BASKET HEIGHT	18 INCHES
BASKET DIAMETER	30 INCHES
BASKET SPEED	0 - 1200 RPM
"G" FORCE	600 @ 1200 RPM
TIMER RANGE	0 - 10 MINUTES (SELECTABLE WITH ANALOG TIMER) OR 0 - 90 MINUTES (PROGRAMMABLE WITH DIGITAL TIMER)
DRIVE TYPE	DIRECT (INVERTER)
MOTOR SIZE	5 H.P.

### ELECTRICAL SERVICE

208-240V / 60Hz / 3 PHASE	20 AMP SERVICE
380-460V / 60Hz / 3 PHASE	15 AMP SERVICE

### PNEUMATIC SERVICE

80 - 100 PSI

### DIMENSIONS

HEIGHT TO CURB TOP	43 INCHES
OVERALL HEIGHT	49 INCHES
DRAIN HEIGHT	11.5 INCHES
DRAIN SIZE	2 INCH O.D.
FLOOR AREA REQUIRED	37"W x 43"D
NET WEIGHT	950 POUNDS
SHIPPING WEIGHT	1150 POUNDS

# **OPERATING INSTRUCTIONS**

## **A. Description of controls:**

### 1. START BUTTON:

The start button is used to start the machine if all the safety circuits have been satisfied and the MAN. AUTO switch is in the MAN position. It contains a green light which turns on whenever the lid is locked.

### 2. MAN. AUTO SWITCH:

The MAN. AUTO switch is a two position switch which controls the method of starting the machine. In the MAN. position the machine starts when the START button is pushed. In the AUTO position the machine will start as the lid closes. After the end of the machine cycle, the lid must be opened before another cycle can be started. This is true in either position of the MAN. AUTO switch.

### 3. SPEED SELECTOR SWITCH:

The SPEED selector switch is a three position switch which controls the speed of the centrifuge. The three speeds are programmed into the inverter. These speeds may be changed by adjusting the parameters in the inverter. The three programmed speeds are: 800 RPM, 1000 RPM, and 1200 RPM.

### 4. STOP SWITCH:

The STOP switch is a maintained push button switch which may be used to stop the centrifuge in case of excessive vibration or other occurrence that requires immediate stopping of the centrifuge. It must be pulled out in order to start the machine.

### 5. TIMER:

The TIMER determines the amount of time that the centrifuge runs before it begins to decelerate. A green light in the timer indicates that is energized. (If the machine has a digital timer, it will count down to indicate that a run signal has been received.) After the cycle is complete, the timer will remain in a timed out condition until the lid is opened.

## **B. Loading Product:**

1. Never load basket with more than the dry weight capacity or above the top.
2. Load evenly for a balanced load. Never allow anything to hang over the top of the basket.
3. Loads should remain several inches below the inside of the basket top. Do not load above the holes in the basket.

### **C. Operation:**

1. The machine is equipped with a timer with a range of 0 -10 minutes (longer times are optional). The timer is located on the side of the machine. Locate the timer and turn the knob. Set the small black hand to the desired length of cycle . If the digital timer is installed, push the 'SET' button to display the setting, then use the arrow keys (▲) to adjust the time. Push 'ENT' to accept the new time. NOTE: If the display reads 'LOC' when trying to change the time, then the keypad is locked. The timer must be removed from the panel to unlock the keypad.
2. Lift the lid and remove the basket from the machine. Load the basket evenly (no higher than the perforated holes in the basket sides). Place the basket into the machine. Close the lid completely and pull out the STOP button (if it is depressed). Press the green START button.
3. The lid lock / run light (located in the start button) will turn on, the lid will lock and the machine will run for the time set on the timer. Do not try to open the lid while the start button is lit.
4. At the end of the cycle, the machine will stop and automatically open. After the basket has been refilled with wet product and placed back into the machine, close the lid. If the MAN. AUTO switch is in the AUTO position, the machine will start automatically. If the switch is in the MAN. position, the START button must be pushed to start the machine.

### **D. Operation of Safeties:**

1. The lid must be closed before the machine can be started. A proximity sensor senses the closure of the lid. The sensor is located inside the control box. The lid must be firmly closed for the sensor to allow the machine to operate.
2. The lid is latched or opened by means of two air cylinders controlled by a three way solenoid valve. When the machine is off, the lid is held up for ease of loading, When the machine is running, the lid is held down.
3. The lid solenoid is controlled by the inverter which runs the motor. When the motor is running, a signal from the inverter keeps the solenoid valve energized to lock the lid. When the rotation of the motor stops, the inverter de energizes the solenoid valve, allowing the lid to open.
4. Failure of any safety switch or overload device will automatically cause the machine to come to a stop. The failure must be corrected before the machine will restart.

**IF ANY OF THESE SAFETIES ARE NOT WORKING CORRECTLY, THE MACHINE SHOULD BE TAKEN OUT OF SERVICE IMMEDIATELY. CALL (419) 726-2645 FOR ASSISTANCE.**

## **SEQUENCE OF OPERATION MODEL FP95**

### **I. STARTING SEQUENCE:**

- A. CLOSE THE LID: This activates the lid closed sensor which energizes the lid closed relay, CR1.
- B. STARTING THE MACHINE (MAN. AUTO switch in the MAN. position) - The depression of the start button energizes the START relay, CR2, for two seconds. CR2 energizes the lid solenoid valve and the RUN relay, CR3. The green light in the START switch will turn on. CR3 is held on through the lid closed relay, CR1. CR3 also allows power to be applied to the TIMER, which provides a contact closure to the inverter run terminals.
- C. STARTING THE MACHINE (MAN. AUTO switch in the AUTO position) - The closing of the lid energizes the START relay, CR2, for two seconds. CR2 energizes the lid solenoid valve and the RUN relay, CR3. The green light in the START switch will turn on. CR3 is held on through the lid closed relay, CR1. CR3 also allows power to be applied to the TIMER, which provides a contact closure to the inverter run terminals.

### **II. STOPPING SEQUENCE:**

- A. Elapsed time, per the pre-set timer cycle, expires. (Or stop button is pushed.)
- B. (MAN. AUTO switch in the MAN. position) - The inverter begins to slow the machine at a predetermined rate. After the machine stops (approximately 60 seconds) the 'motor running' contacts of the inverter will open, releasing CR2 which in turn releases the lid solenoid valve, opening the lid. The green light in the START switch will turn off. When the lid opens, CR3 releases, resetting the timer. After the lid is closed, the machine may be restarted.
- C. (MAN. AUTO switch in the AUTO position) - The inverter begins to slow the machine at a predetermined rate. After the machine stops (approximately 60 seconds) the 'motor running' contacts of the inverter will open, releasing CR2 which in turn releases the lid solenoid valve, opening the lid. The green light in the START switch will turn off. When the lid opens, CR3 releases, resetting the timer. After the lid closes, CR2 energizes through the MAN. AUTO switch and restarts the process.

**FP-95**  
**SERVICE MANUAL**



## INTRODUCTION

This manual provides specific step by step instructions to assist in repairing and replacing specific parts of your machine. It is designed to be used in conjunction with other materials including parts lists, parts manual, electrical diagrams, trouble shooting guide, preventive maintenance schedule and the summary of safety information. Together, they provide adequate information to repair most of the machine.

**ALWAYS REMOVE POWER FROM THE MACHINE BEFORE PERFORMING ANY SERVICE**

### TABLE OF CONTENTS

REMOVE BASKET	A
REPLACE BASKET	B
REPLACE STAINLESS STEEL BALL CAP	C
REMOVE CURB	D
REPLACE CURB	E
REMOVE OR REPLACE CENTER UNIT, TRUNNION CAPS AND PULLEY	F
REPLACE TRUNNION FRAME ASSEMBLY	G
REMOVE OR REPLACE BELT GUARD OR BELTS	H
REPLACE MOTOR, MOTOR PULLEY AND MOTOR PULLEY HUB	I
REMOVE AND REINSTALL CONTROL PANEL COVER	J
REPLACE LID OPEN SOLENOID VALVE	K
ADJUST OR REPLACE LID CLOSED SENSOR	L
LUBRICATE AND ADJUST LID HINGE BRAKE	M
LUBRICATE AND ADJUST LID LOCK LEVER	N
REPLACE LID HINGE, LID CLOSED LEVER, LID HINGE FRAME, LID HINGE BRAKE AND LID LOCK CAM	O
REPLACE TIMER	P
TIMER – SETTING & KEYPAD LOCK: (DIGITAL TIMER ONLY)	Q
REPLACE OTHER ELECTRICAL PARTS	R

## A REMOVING THE BASKET:

The basket is heavy (300# empty). You will require assistance to remove the basket. Do not place your hand or fingers between the basket and curb sidewall. Do not drop the basket.

Raise the lid and secure it in the open position. The basket can be lifted straight up and out of the machine. The FP-95 machine is supplied with a lifting yoke to assist in basket removal.

## B REPLACING THE BASKET:

**CAUTION:** The basket is heavy (300# empty). Use the lifting yoke and an overhead hoist.

Before replacing the basket inspect the (#3588) ball cap for any sign of wear. Replace it if necessary. Inspect the corners of the hex ball. If they are rounded replace the it. If the hex ball is found to be damaged or worn, inspect the inside of the center post of the basket.

Grease the top of the hex ball with a medium weight lithium grease. Failure to do so may result in excessive vibration and/or excessive wear to the basket center post and to the hex ball.

Examine the drain to verify that it is not blocked.

Place the basket gently onto the basket ball. Do not drop the basket. Rotate the basket by hand until it engages the hex ball and seats into position. If vibration occurs after replacing the basket try it in another position on the ball. Six positions are possible.

## C REPLACING THE BALL CAP

Remove the basket following the instructions in step "A". Remove the Phillips head screw in the center of the ball cap. This screw threads into the end of the shaft and secures the ball cap to the shaft. Use a screw driver under the edge of the ball cap to pry it off. The ball cap snaps into and out of place.

To replace the ball cap, place it in the proper position (the end of the shaft is square as is the inside of the ball cap) and seat it into place using a rubber mallet. Replace the Phillips head screw and tighten to shaft.

Lightly grease the top of the hex ball with medium weight lithium grease. Gently replace the basket into the machine following the same procedure as step "B".

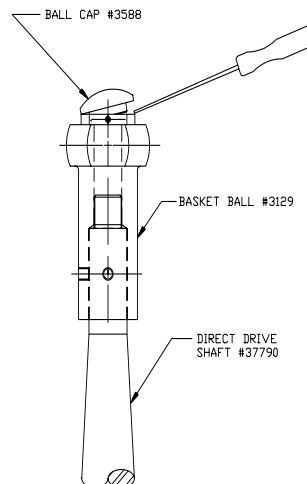

**D REMOVING THE CURB:**

Remove the basket as described in step "A". Remove the three fasteners which secure the curb to the skirt legs. They are located at the bottom inside of the curb. Lift off the curb. The curb needs to be lifted straight up so to clear the drive ball and shaft. Note that the curb is mounted on rubber gaskets located between the bottom surface and the top of the skirt legs. It may be stuck. If so, simply rock until it is free. This is also a good opportunity to inspect and replace the trunnion rubbers #2400-293 and the bumper rubbers #2400-444.

**E REPLACING THE CURB:**

Inspect the (#3168) gaskets on the skirt leg tops. Replace them if necessary. Lift the curb and guide it so that the center curb hole clears the drive unit ball and shaft. Line up the three holes in the curb bottom with the holes in the skirt legs. Replace the three fasteners. Be certain that the washers and gaskets are on the fasteners. The gasket goes against the bottom of the curb. Lower the lid and check the alignment between the curb and the lid. If the curb and lid are misaligned, tighten the appropriate fastener to adjust the alignment. CAUTION: Do not over tighten so that the curb bottom is bent. Replace the basket per step "B". When finished, check the curb for leaks around the fastener holes.

**F REMOVAL AND REPLACEMENT OF CENTER DRIVE UNIT, TRUNNION CAPS AND PULLEY**

Remove the basket and curb per steps "A" and "D". Remove the two bumper rubber caps #2400-444 (2 bolts per cap). Note that there is a lip on the underside of the bumper cap. This lip orients toward the outside of the machine. Be sure when reassembling to position them in the same orientation. To free the drive belt(s), loosen the four studs which are located on the adjustable motor base. Then turn the adjusting bolt counterclockwise to remove tension from the drive belt(s). Remove the drive belt(s) and lift the center drive unit straight up and out of the skirt and set off to the side. (CAUTION: this unit weighs approximately 100 lbs.)

To change the pulley sheaves, remove the drive unit per paragraph above. Remove the threaded fasteners holding the pulley hub to the sheave. Replace the sheave and reassemble. To remove the pulley hub from the shaft, remove the set screw and pull the hub from the shaft. Some force may be necessary to free the hub from the shaft. Do not lose the drive shaft key.

Replace the pulley hub and sheave in the same position as it was. Note that when the drive unit is back in place, the drive unit pulley and the motor pulley must be in the same plane. Re-install all of the drive unit mounting hardware and tighten. **DOUBLE CHECK TO ASSURE THE DRIVE BELT(S) ARE PROPERLY SEATED IN THE PULLEYS PRIOR TO OPERATING THE MACHINE.**

Test the movement of the drive unit. Stand at the front left of the machine and rock the drive unit shaft away from and toward you. The top of the shaft should move approximately 3/8". If it is too loose check the trunnion and bumper rubbers for wear.

## **G REPLACING THE TRUNNION RING BUMPERS:**

Remove the center drive unit per step "F" above. Remove the three trunnion caps #1034 in order to free the trunnion frame assembly #2400-472 for removal. **MARK THE TRUNNION RING POSITION TO INSURE PROPER POSITIONING WHEN REASSEMBLING.** Remove the old bumpers from the trunnion ring and replace with new (#2400-293). Lift the trunnion frame assembly into position in the skirt assembly being sure to properly seat the trunnion bumpers on their hangers. Replace the three bumper caps noting that the lip on the inside of the cap is toward the outside of the machine. Securely tighten the bolts holding the caps.

## **H REMOVAL OF BELT GUARD AND REPLACEMENT OF BELT(S):**

To remove the belt guard cover, loosen the bolts and lift the cover off. Loosen the motor and belt per step "F". Remove the belt guard by removing the four hex head bolts which are located directly below the adjustable motor bracket. Remove the hex head bolt located on the opposite side of the belt guard. Slide the belt guard straight back removing it from the machine. Put the new belts on the center drive unit pulley first and then onto the motor pulley. **CHECK THAT THE BELTS ARE PROPERLY SEATED INTO THE CENTER DRIVE UNIT AND MOTOR PULLEY GROOVES BEFORE OPERATING THE MACHINE.** Do not over tighten the belts. They should be as loose as possible without slipping. Allow 1/2" of flex at mid point of the belt after tightening. Reinstall the belt guard and the belt guard cover.

## **I REPLACING THE MOTOR OR MOTOR PULLEY:**

Remove the belt guard from the motor mount per step "H". Remove the drive belt per step "F". Disconnect the conduit from the junction box on the motor. Disconnect the wires from the motor, marking each for easy reconnection. See the electrical diagram for details and wire locations. If changing pulley only, simply remove the motor from the motor mount and turn motor on its' side.

To replace the motor pulley or the pulley hub, loosen and remove the three cap screws. Insert two of the cap screws into the tapped removal holes and tighten evenly until the pulley loosens from the hub. Remove the pulley. To remove the pulley hub, loosen the set screw and slide the hub from the shaft. Do not lose the shaft key. To reinstall the pulley hub, insert the key into the shaft keyway and slide the hub onto the shaft. Position the hub on the shaft at the same location as it was before removal. re-tighten the set screw. To reinstall the pulley, hand start the three pulley mounting bolts and tighten evenly and progressively. Never allow the pulley to be drawn into contact with the flange of the bushing. The gap between the pulley and the flange should be 1/8" to 1/4".

If the motor is to be replaced, see the wiring diagram in the owners manual. Reinstall the belts and belt guard reversing step "H" above.

**NOTE:** If the inverter that drives the motor is a model G5, it will need to be tuned to the motor. Follow the instructions on Auto Tuning in the inverter initialization procedure, Step 7.

## **J        REMOVAL AND REPLACEMENT OF CONTROL PANEL COVER**

### **TURN OFF ALL POWER TO THE MACHINE BEFORE REMOVING ANY COVER.**

To remove the back panel, remove twelve hex head screws from the panel. If the panel sticks to the box, lightly pry loose at the gasket. To replace the back cover panel, hand start all of the screws and tighten evenly until the gasket compresses and seals.

## **K        REPLACEMENT OF THE LID OPEN SOLENOID VALVE**

**CAUTION - TURN OFF THE POWER AND THE AIR TO THE MACHINE.** Remove the control panel cover. Remove the air lines from the solenoid. Mark and remove the wires from the terminal block. Remove the screws holding the solenoid mounting bracket to the panel. Remove the solenoid from the bracket. Replace the old solenoid with the new. Be sure to check that the voltage of the replacement solenoid is the same as that of the one being removed. Replace the solenoid bracket. Re-install the air lines. Replace the wires onto the terminal block. Make sure that the wires are installed to the same terminals from which they were removed. See the wiring diagram if you are unsure of their placement.

Turn machine power on and test run through a cycle to verify that the lid lock solenoid and sensor are in proper adjustment. LID ADJUST - Adjust the incoming air pressure so lid just raises at end of cycle. Change pressure by lifting the locking ring on the top of the regulator, turning slightly to adjust the pressure, and then pushing down on the ring to re-lock it.

Turn off the power and reinstall the control panel cover (per step "J" above).

## **L.        ADJUSTING OR REPLACING THE LID CLOSED SENSOR**

Remove the control panel cover per step "J".

Mark and remove the wires from the sensor to the terminal block. Remove and replace the sensor, leaving a space of about 3/32" between the sensor face and the target (when the lid is closed). Replace the wires in the same terminal positions from which they were removed.

Turn the power on to the machine and run a test cycle. If the sensor fails to operate, the machine will not run. An indicator light at the cable end of the sensor will turn on when the sensor is activated. After a successful test run, turn off the power and replace the control panel cover.

## **M.        LUBRICATING AND ADJUSTING THE LID HINGE BRAKE (NON-PNEUMATIC MACHINES ONLY)**

### **1.    Lubrication (every 60 days):**

Remove the control panel cover (part #2291SS) per Step "J". Use a medium weight lithium grease on the 5/16" grease fitting located on the lid hinge brake (part #2399-B).

### **2.    Lid Adjustment:**

Open and close the lid. Stop at various distances above the machine curb. The lid should maintain its' position and should not fall freely. It should be easily moved open or closed from these locations.

If the lid is too loose, tighten the #2398 bolt on the lid hinge brake. Re-check the movement and re-adjust if necessary.

If the lid is too tight, loosen the #2398 bolt and recheck.

**N. LUBRICATING AND ADJUSTING THE LID LOCK LEVER (NON-PNEUMATIC MACHINES ONLY)**

Remove the control panel cover (part # 2291SS) per step "J".

**1. Lubricating:**

To lubricate the lid lock lever, apply medium weight lithium grease to the 5/16" grease fitting located on the lid lock lever itself.

**2. Adjusting the lid lock lever:**

Proper adjustment of the lid lock lever is verified if the lid cannot be opened more than 1/2" above the curb when the lid lock solenoid is actuated. If the lid can be opened more than the allowed 1/2", loosen the lock nut on the # 2256-B bolt and adjust the # 2256-B bolt until its' head is within the thickness of a nickel of the vertical surface of the lid lock cam (# 2253-B). Re tighten the lock nut. This adjustment should still allow the lid lock solenoid to freely activate.

If the lid lock lever cannot close completely, loosen the lock nut on the adjusting bolt and adjust the bolt inward. Again, the gap between the head of the bolt and the vertical surface of the lid lock lever should be approximately the width of a nickel.

Operate the lid lock lever several times to test the adjustment. If a gap of 1/2" or less exists between the lid and the curb, the adjustment is correct. Reinstall the control panel cover.

**O. REPLACING THE LID HINGE, LID SAFETY CAM, LID HINGE FRAME, LID HINGE BRAKE AND THE LID LOCK CAM:**

1. Remove the control panel cover (# 2291-SS) per Step "J".
2. Loosen the set screws on the lid safety cam and the lid lock cam. Slide the lid lock cam toward the outside of the control panel box. Remove the square shaft key from the lid hinge shaft #3208.
3. Remove the lid hinge brake adjusting bolt #2398 and save.
4. Remove the two hex socket head cap screws which hold the lid hinge frame to the lid hinge shaft. **CAUTION:** Use a 3/16" dia. brass rod or other soft metal to drive the screws clear out of the lid hinge and shaft. Using a hard metal rod will damage the screws.
5. Using a 1/2" dia. brass rod or other soft metal, slowly drive the lid hinge shaft through the lid hinge frame and control panel box. Be sure that the lid hinge brake does not bind on the shaft as the shaft is being driven outward.
6. If only the lid lock cam or the lid safety cam are being replaced, drive the shaft out only far enough to slip the old parts off for replacement with the new. If the shaft is being replaced, remove it completely from the control panel box. Take care to note the locations of the two nylon washers located between the lid frame and the control panel box on both sides.
7. Slide the new (or old) lid hinge shaft through the lid hinge frame and into the control panel box. Be sure to replace the nylon washers between the control panel box and the lid frame on both sides. A soft brass rod may be used to assist in pounding the shaft into location. **NOTE:** There may be water proofing rubber washers (part # 2400-149G) glued to each side of the control panel box. Be sure that these are not loose. Grease may be used on the shaft to allow the it to slide more freely through these washers. If the rubber washers are broken or loose, replace them and glue them to the control panel box with contact cement.

8. Replace the lid safety cam, lid hinge brake and the lid lock cam onto the shaft before driving the lid hinge shaft through the opposite side of the control panel box. Be sure that the nylon washers are in place as described in paragraph 7.
9. Center the lid hinge shaft.
10. Install the square shaft key into the keyway on the lid hinge shaft. Slide the lid lock cam over the key and lock in place using the set screw provided.
11. Close the lid and turn the hinge shaft so that the flat surface of the lid lock cam is vertical.
12. Reinstall or tighten the lid hinge brake bolt to lock the shaft in place (this prevents the shaft from turning during the next assembly operation).
13. Recheck the location and position of the lid lock cam. Be sure it is in the correct location and position.
14. Drill two 1/4" dia. (or "D" drill dia.) holes through the shaft using the holes in the lid hinge frame as guides.
15. Install the hex socket head cap screws through the lid hinge frame and shaft and tighten securely.
16. Readjust the lid hinge brake per paragraph "M.2", the lid lock lever per paragraph "N.2", the lid closed and lid locked micro switches per paragraphs "L.1" and "L.2".  
Test run the machine for several cycles to assure that all adjustments are correct.
17. Replace the control panel cover per paragraph "J".

**P. TIMER REPLACEMENT (OUTSIDE TIMER ON REMOTE ELECTRICAL PANEL):**

Turn the internal circuit breaker to the off position. Loosen the screw on the front face of the timer. Lift the handle of the timer until it releases and can be pulled outward from the timer case. Install the new timer and lock into place reversing the procedure for removing. The plastic timer case does not normally need to be replaced, however it is recommended that the internal connections be checked for evidence of arcing or corrosion. Replace the case if any is observed.

**Q. TIMER – SETTING & KEYPAD LOCK: (DIGITAL TIMER ONLY)**

**SETTING:** Press the **SET** button. Use the arrow key (▲) beneath each digit to set the desired time. When finished, press the **ENT** key to store the time. If the display alternates between the setting and ‘LOC’, the keypad must be unlocked. (See next step.)

**KEYPAD LOCK:** Remove the timer per the previous step. At the bottom rear of the timer face is a 7 position DIP switch. Push position 4 ‘in’ at the top to lock the keypad. Push position 4 ‘in’ at the bottom to unlock the keypad. Reinstall the timer and lock into place reversing the procedure for removing.

**R. REPLACEMENT OF OTHER ELECTRICAL PARTS:**

**Turn off power to the machine.** Mark and remove the wires leading to the part needing replacement. Remove the old part and replace with the new. **NOTE:** always check the voltage of the new part to be sure that it is the same as that of the old part. Reconnect the marked wires to the new part. Be sure to connect them in the same locations on the new part as they were on the old part. See the electrical wiring diagram for details.

Test run the machine and reinstall the control panel cover.



## MAINTENANCE AND SERVICE NOTICE

ALL NSEP centrifuges are provided with safety interlocks to prevent the opening of the lid while the basket is spinning. These safety features are designed to allow for extended service and continued use. Their effectiveness, however, can be impaired by customer misuse of the centrifuge or the failure of the owner to provide regular maintenance. This type of equipment is typically used on a constant basis and **preventive maintenance is required to prevent injury** especially to the unwary.

Proper lubrication and maintenance will provide excellent machine longevity.

A parts manual is included as part of this complete service manual. The parts are described in the parts list. Please use this information to identify and describe the parts when ordering replacement parts. In addition, when ordering, please provide the name plate data including model, serial number and electrical specifications.

## TROUBLE SHOOTING GUIDE MODEL FP95

### Problem and possible cause

### Potential correction

1. Machine fails to start  
No power to machine

Main breaker off.  
Internal circuit breaker off or tripped.

Lid not completely closed

Close lid - verify that the light on the sensor is on and that CR1 is energized. The lid closed proximity sensor must sense a lid closed position for the machine to start.

Motor doesn't start  
Green timer light is on, (or timer is counting).

STOP button is depressed.  
No air supply to machine.  
Defective pressure switch.  
Defective timer.  
Defective inverter.

Motor doesn't start  
Green 'run' light is off.  
Green timer light is off, (or timer not counting).

Replace start relay.  
See 'lid not closed' above.

Motor doesn't start  
Green 'run' light is on.  
Green timer light is off, (or timer not counting).

Replace timer.  
Replace run relay  
See 'lid not locked' above.

- |   |   |
|---|---|
| <p>2. Machine keeps running/excessive stopping time<br/>         Drive belt loose<br/>         Timer has failed.<br/>         Braking resistor(s) defective</p> | <p>Tighten belt<br/>         Replace timer<br/>         Replace resistor(s)</p>   |
| <p>3. Excessive vibration<br/>         Motor mount rubber is worn<br/>         Motor hanger cap is loose</p>  | <p>Replace motor mount rubbers.<br/>         Tighten the caps - The rubber must be tight.</p>   |
| <p>The lid falls freely when opened.</p>  | <p>1. No air supply to machine.<br/>         2. Defective solenoid valve.<br/>         3. Defective air cylinders.</p>  |
| <p>The lid stays locked and the light stays on but the machine has stopped.</p>   | <p>Remove wire 35 from terminal 1 of TR-1. If the lid releases, replace TR-1.<br/>         Replace CR-2<br/>         Defective inverter</p>   |
| <p>Noise heard during acceleration or deceleration.</p>   | <p>1. The top or bottom drive unit bearing is failing.<br/>         2. See next step.</p>   |
| <p>Excessive noise or vibration</p>   | <p>1. Something wrapped around the drive shaft<br/>         2. Basket not fully engaged with the hex. ball.<br/>         3. Worn drive shaft.<br/>         4. Replace the pulleys.<br/>         5. Replace the bumper and trunnion rubbers.<br/>         6. Inspect the hex ball for wear. Replace if worn.<br/>         7. Inspect the center post for wear.<br/>         8. Inspect the machine mounting fasteners for tightness.</p> |

Excessive starting current.

1. Something wrapped around the shaft.
2. Bad bearing in the drive unit or motor.
3. The belt tension is too tight.
4. Shaft is worn.
5. Basket is overloaded.

Water on center drive unit.

1. Curb drain has a restriction.

**SCHEDULED MAINTENANCE PROGRAM  
MODEL FP95**

\*\*\*\*\*

- \* Read thoroughly before operating your centrifuge.
- \* Your NSEP centrifuge requires scheduled maintenance.
- \* Always disconnect power before working on any part of the centrifuge.
- \* For your safety, never force the lid open.
- \* Do not attempt to load or unload if the basket is spinning.
- \* Always instruct end users on all operational and safety procedures prior to their operation of the centrifuge.

\*\*\*\*\*

**I. WEEKLY LUBRICATION PROCEDURE**

- A. After each 40 hours of usage, add approximately 5 ounces of grease to the grease fitting located on the upper portion of the skirt between the drain and the machine control panel. The recommended grease is BP Energrease LC-EP 2 or equivalent.

**II. MONTHLY PROCEDURES**

- A. Inspect the drive belt.
- B. Perform weekly procedures as described above.
- C. Inspect and test the SAFETY SYSTEM:
  - 1. VISUAL INSPECTION:
    - a. Verify that the back panel is securely fastened to the control box.
    - b. Verify that the mounting bolts are tight.
  - 2. START THE MACHINE:
    - a. The lid should be closed and locked.
    - b. The run light (in the start button) should be illuminated.
  - 3. STOP THE MACHINE:
    - a. Depress the stop button.
    - b. Machine should stop in approximately 60 seconds.
    - c. The machine run light should turn off.
    - d. The lid should open automatically after the machine has stopped.

4. RESTART THE MACHINE:
  - a. Close the lid and depress the start button.
  - b. The machine should run a complete cycle and stop in approximately 60 seconds after the completion of the cycle.
  - c. The machine run light should be on during the entire cycle and should turn off after the motor has stopped spinning.
  - d. The lid should open automatically after the machine has stopped.
  - e. The basket should be stopped when the lid opens.
  
5. RESTART WITH LID OPEN TEST:
  - a. Attempt to start the machine with the lid open.
  - b. The machine should not start with the lid open. If the machine starts with the lid open, immediately remove the machine from service.
  - c. Start the machine with the lid closed.
  - d. Stop the machine as in step 3. of the safety test above.
  - e. After the machine has completely stopped, attempt to restart the machine with the lid open by depressing the start button.
  - f. The machine should not restart with the lid open. If the machine restarts with the lid open, immediately remove the machine from service.

\*\*\*\*\*

**IF THE SAFETY SYSTEM IS NOT WORKING PROPERLY OR IF ANY LABELS ARE MISSING OR ILLEGIBLE IMMEDIATELY REMOVE THE MACHINE FROM SERVICE AND CALL THE FACTORY AT (419) 726-2645.**

\*\*\*\*\*

### III. SEMIANNUAL PROCEDURES

- A. Remove the stainless steel CURB. (See step "D" of the Service Manual) Inspect motor mounting rubbers. Replace mounting rubbers if the motor is loose.
  
- B. Perform weekly and monthly procedures as described above.

## FP-95 G5 INVERTER INITIALIZATION PROCEDURE

(PROVIDED FOR REFERENCE ONLY)

**NOTE: This manual contains information on three different styles of inverters. This programming procedure is for the G5 inverter, and is performed at the factory prior to machine testing. Info on the ACS400 and the ACS550 inverters follow this procedure. Contact NSEP Before Making Any Changes to the Inverter Program.**

### TO PROGRAM ANY VARIABLE:

Press "MENU" key.

Use up or down arrows to locate desired menu.

Press "DATA/ENTER" to access desired menu.

Use up or down arrows to locate specific variable. The present value is displayed.

Press "DATA/ENTER" to access or change the desired variable.

Use Arrows to change to the new value.

Press "DATA/ENTER" to accept the new value.

Check for the words "Entry Accepted" to flash on the display.

Use ESC to back up one level at a time.

Press MENU to return to start.

When finished, press MENU then DATA/ENTER; the DRIVE and FWD lights will turn on. Push the LOCAL/REMOTE switch to toggle between operation by the keypad or the machine.

### FOR FIRST TIME START-UP:

1. Check out wiring.
2. Apply power to machine.
3. Press "MENU" key, then arrow to access the INITIALIZE menu.
4. Change the Init Parameter, A1-03 to **2220** (2-Wire Initial).
5. Change the Access Level, A1-01 to **4** (Advanced).
6. Verify that the control method, A1-02 = **2** (Open Loop Vector).

Use MENU to exit initialization. Access the Auto Tuning menu.

#### Remove the drive belt from the motor.

Auto tuning allows the inverter to automatically set the motor parameters, (E2), for each particular motor. This procedure is also required if the motor is replaced.

Enter the parameters as required for auto tuning.

Rated Voltage	Enter the motor nameplate voltage. <b>(200, 230, 460)</b>
Rated Current	Enter the motor nameplate current. <b>(15.6, 13.6 6.8)</b>
Rated Frequency	Enter the motor nameplate frequency. <b>(50 or 60 Hz.)</b>
Rated Speed	Enter the motor nameplate speed. <b>(1725, 1740, 1800)</b>
Number of Poles	<b>4</b>
Select Motor 1/2	<b>1</b>
Tuning Ready?	'Press RUN Key' will be flashing.

If all the motor parameters have been entered, and the drive belt has been removed from the machine, press the **Run** key. During tuning 'Tune Proceeding' will flash on the display. After tuning is complete, (1-2 minutes), 'Tune Successful' will be displayed.

After auto tuning is completed, replace the drive belt(s) onto the machine.

Use MENU to exit auto tuning. Access the Programming menu.

Group b (Application), Function b1 (Sequence)

If using a **potentiometer** for speed adjustment, b1-01 = **1**. (Reference Source - Terminals)

If using a **selector switch** for speed adjustment, b1-01 = **0**. (Reference Source - Operator)

b1-02 = **1** (Run Source - Terminals)

Use ESC to back up one level.

Function b2 (DC Braking)

b2-01 = **0.5** Hz (DC Inj Start Freq)

b2-02 = **100%** (DC Inj Current)

b2-04 = **8** Sec (DC Inj Time @ Stop)

Use ESC to back up two levels.

Group C (Tuning), Function C1 (Accel/Decel)

C1-01 = **60** Sec (Accel Time 1)

C1-02 = **60** Sec (Decel Time 1)

Use ESC to back up two levels.

**NOTE:** Only set d1-01, d1-02, d1-03 & d1-04 if using a selector switch to set speeds; not if using a potentiometer. If using a potentiometer, these parameters are not used.

Group d (Reference), Function d1 (Preset Reference)

If using a three position selector switch:

d1-01 = **50** Hz (1000 RPM)

d1-02 = **40** Hz(800 RPM)

d1-03 = **60** Hz (1200 RPM)

If using a four position selector switch:

d1-01 = **40** Hz (800 RPM)

d1-02 = **30** Hz(600 RPM)

d1-03 = **50** Hz (1000 RPM)

d1-04 = **60** Hz(1200 RPM)

Use ESC to back up two levels.

Group E (Motor), Function E1 (V/F Pattern)

E1-09 = **0.0** Hz (Min Frequency)

Use ESC to back up two levels.

Group H (Terminal), Function H3 (Analog Inputs)

If using a **potentiometer** for speed adjustment, H3-05 (Term 16 Sel) = **0**. (Aux Reference)

If using a **selector switch** for speed adjustment, H3-05 (Term 16 Sel) = **1F**. (Not Used)

Use ESC to back up two levels.

Group L (Protection), Function L1 (Motor Overload)

L1-02 = **3.0** min (MOL time constant)

Use ESC to back up one level.

Function L3 (Stall Protection)

L3-04 = **0** (StallP Decel Sel)(Disabled - This allows the braking resistors to work properly.)

Use ESC to back up two levels.

Group o (Operator), Function o1 (Monitor Select)

o1-01 = **5** (User Monitor Sel - Motor Speed)

Use ESC to back up one level.

Function o2 (Key Selections)

o2-08 = **1** (Elapsed Time Run - Running Time)

o2-03 = **1** (User Defaults). Will accept then change back to 'No Change'. This stores the user defaults, so it must be the last parameter stored.

Push MENU

Push DATA/ENTER

### **TO ADJUST SPEED ONLY**

Use the instructions TO PROGRAM ANY VARIABLE at the beginning of this procedure for general instructions on programming the G5 inverter.

Press the MENU button.

Use arrows to access Group d (Reference), Function d1 (Preset Reference)

d1-02 is preset speed 1.

d1-01 is preset speed 2.

d1-03 is preset speed 3.

Push MENU

Push DATA/ENTER

### **TO CALCULATE FREQUENCY FOR A DESIRED SPEED**

The output frequency of the inverter varies from 0 to 60Hz. This corresponds to speeds from zero to 1200 RPM.

The formula  $\text{DESIRED SPEED} / \text{MAXIMUM SPEED} \times 60 = \text{DESIRED FREQUENCY}$  provides the required output frequency for any desired speed. For example, if 900 RPM is desired, the formula becomes  $900 / 1200 \times 60$  which equals 45Hz. This can be programmed into any of the three preset speeds. (See previous step.)



**INITIALIZATION ROUTINE  
FOR MODELS.FP-90/95 WITH MODEL ACS400  
ELECTRONIC VARIABLE SPEED CONTROL  
50 or 60 Hz OPERATION**

**IMPORTANT -- BE SURE TO CHECK WIRING PER WIRING CHECK-OUT SHEET!!  
IMPROPER WIRING CAN CAUSE DAMAGE TO ELECTRONIC DRIVE PANELS.**

**TO PROGRAM ANY VARIABLE:**

Press "MENU" key.

Use up ▲ or down ▼ arrows to locate desired menu.

Press " ENTER" to access desired menu.

**NOTE: The item that will be changed with the arrow keys will be underlined.**

Use up or down arrows to locate specific variable. The present value is displayed.

Press " ENTER" to access or change the desired variable. The present value is underlined.

Use Arrows to change to the new value.

Press " ENTER" to accept the new value.

Use MENU to back up one level at a time, multiple times to exit.

When finished, press MENU until the display reads 0.0 Hz. Push the LOCAL/REMOTE switch to toggle between operation by the keypad or the machine. The switch must be held while the display scrolls through the options. Use LOCAL, KEEP RUN to run from the inverter.

**FOR FIRST TIME START-UP:**

1. Check out wiring.
2. Power up unit.
3. Press "MENU" key, then ▲ arrow to access FULL/SHORT menu. Push & hold ENTER until an asterisk \* appears on the right side of the display.

Use ▼ arrow to access Group 99 – START-UP DATA.

9902	APPLIC MACRO	Set to <b>1</b> (ABB standard)
9905	MOTOR NOM VOLT	Enter the motor nameplate voltage. (230, 460)
9906	MOTOR NOM CURR	Enter the motor nameplate current. (13.6, 6.8)
9907	MOTOR NOM FREQ	Enter the motor nameplate frequency. (60 Hz.)
9908	MOTOR NOM SPEED	Enter the motor nameplate speed. (1725, 1745, 1800)
9909	MOTOR NOM POWER	Enter the motor nameplate power. (5Hp)
9910	MOTOR COS PHI	Enter the motor nameplate power factor. (.83) or leave at default value if not listed on motor nameplate.

Use MENU to back up 1 menu. Access Group 10 – COMMAND INPUTS.

1001 Ext 1 Commands 1 = **DI 1** 2 Wire start & stop.

Use MENU to back up 1 menu. Access Group 12 – CONSTANT SPEEDS.

1201	Const speed sel	10 = <b>DI3,4,5</b>
1202	Const speed 1	<b>50</b> Hz (1000 RPM)
1204	Const speed 3	<b>60</b> Hz (1200 RPM)
1206	Const speed 5	<b>40</b> Hz (800 RPM)

Use MENU to back up 1 menu. Access Group 14 – RELAY OUTPUTS.

1401	Relay output 1	<b>RUN</b>
1402	Relay output 2	<b>FAULT</b>

Use MENU to back up 1 menu. Access Group 20 – LIMITS.

2005	Overvolt control	<b>Disable</b>
------	------------------	----------------

Use MENU to back up 1 menu. Access Group 21 – START/STOP.

2102	Stop	<b>Ramp</b>
2104	StopDC Inj Time	<b>8 Seconds</b>

Use MENU to back up 1 menu. Access Group 22 – ACCEL/DECEL.

2202	acceler time 1	<b>60 Seconds</b>
2203	deceler time 1	<b>60 Seconds</b>

Push MENU until the display reads **0.0** Hz

**NOTE: SET TIMER FOR 3 MINUTES**

**TO ADJUST SPEED ONLY**

Use the instructions TO PROGRAM ANY VARIABLE at the beginning of this procedure for general instructions on programming the ACS400 inverter.

**NOTE:** Only set these parameters if using a selector switch to set speeds; not if using a potentiometer. If using a potentiometer, the speed is varied with a 0 - 10 VDC signal into terminal 2 of the inverter. The Group 12 parameters are not used with a potentiometer.

Press the MENU button.

Use arrows to access Group 12 (CONSTANT SPEEDS)

1202	Const speed 1	<b>50</b> Hz (Speed 2 = 1000 RPM)
1204	Const speed 3	<b>60</b> Hz (Speed 3 = 1200 RPM)
1206	Const speed 5	<b>40</b> Hz (Speed 1 = 800 RPM)

Push MENU until the display reads 0.0 Hz.

**TO CALCULATE FREQUENCY FOR A DESIRED SPEED**

The output frequency of the inverter varies from 0 to 60Hz. This corresponds to speeds from zero to 1200 RPM.

The formula  $\text{DESIRED SPEED} / \text{MAXIMUM SPEED} \times 60 = \text{DESIRED FREQUENCY}$  provides the required output frequency for any desired speed. For example, if 900 RPM is desired, the formula becomes  $900 / 1200 \times 60$  which equals 45Hz. This can be programmed into any of the three preset speeds. (See previous step.)

**INITIALIZATION ROUTINE  
FOR MODELS.FP-90/95 WITH MODEL ACS550  
ELECTRONIC VARIABLE SPEED CONTROL  
50 or 60 Hz OPERATION**

**IMPORTANT -- BE SURE TO CHECK WIRING PER WIRING CHECK-OUT SHEET!!  
IMPROPER WIRING CAN CAUSE DAMAGE TO ELECTRONIC DRIVE PANELS.**

TO PROGRAM ANY VARIABLE:

Select "PARAMETERS" in the main menu

Use up ▲ or down ▼ arrows to highlight desired parameter group.

Press "SEL" to access desired parameter group.

**NOTE: The item that will be changed will be highlighted.**

Use up or down arrows to highlight specific variable. The present value is displayed.

Press "EDIT" to access the desired variable. The present value is underlined.

Use Arrows to change to the desired parameter value.

Press "SAVE" to accept the new value, or "CANCEL" to leave the set mode without saving.

Use "EXIT" to return to the listing of parameter groups, "EXIT" again to return to the main menu.

When finished, press EXIT until the display reads 0.0 Hz. Push the LOCAL/REMOTE switch to toggle between operation by the keypad or the machine.

**FOR FIRST TIME START-UP:**

1. Check out wiring.
2. Power up unit.
3. Display reads 'Do you want to use the Start-up assistant?' Select 'No' and press OK.
4. Display reads 'Show start-up assistant on next boot?' Select 'No' and press OK.
5. Press MENU
6. Select 'PARAMETERS' in the main menu.
7. Press ENTER

Access Group 99 – START-UP DATA.

9906	MOTOR NOM CURR	Enter the motor nameplate current. (13.6, 6.8)
9908	MOTOR NOM SPEED	Enter the motor nameplate speed. (1725, 1745, 1800)

Press "EXIT", then access Group 10 – START/STOP/DIR.

1001	Ext 1 Commands	1 = <b>DI 1</b>	2 Wire start & stop.
------	----------------	-----------------	----------------------

Press "EXIT", then access Group 12 – CONSTANT SPEEDS.

1201	Const speed sel	13 = <b>DI3,4,5</b>
1202	Const speed 1 (Speed 2)	<b>50</b> Hz (1000 RPM)
1204	Const speed 3 (Speed 3)	<b>60</b> Hz (1200 RPM)
1206	Const speed 5 (Speed 1)	<b>40</b> Hz (800 RPM)

Press "EXIT", then access Group 14 – RELAY OUTPUTS.

1401	Relay output 1	<b>RUN</b>
1402	Relay output 2	<b>FAULT</b>

Press "EXIT", then access Group 16 – SYSTEM CONTROLS.

1604	Fault Reset Sel	<b>DI2</b>
------	-----------------	------------

Press “EXIT”, then access Group 20 – LIMITS.

2002	Maximum Speed	<b>1745</b>
2005	Overvolt control	<b>Disable</b>

Press “EXIT”, then access Group 21 – START/STOP.

2102	Stop Function	<b>Ramp</b>
2104	DC CURR CTL	<b>DC BRAKING</b>
2105	DC HOLD SPEED	<b>0 RPM</b>
2106	DC CURR REF	<b>100%</b>
2107	DC BRAKE TIME	<b>8 Secs</b>

Press “EXIT”, then access Group 22 – ACCEL/DECEL.

2202	ACCELER TIME 1	<b>60 Sec</b>
2203	DECELER TIME 1	<b>60 Sec</b>

Push EXIT key until the display reads the operating parameters.

### **NOTE: SET TIMER FOR 3 MINUTES**

**SETTING:** Press the **SET** button. Use the arrow key (▲) beneath each digit to set the desired time. When finished, press the **ENT** key to store the time. If the display alternates between the setting and ‘LOC’, the keypad must be unlocked before the value will be accepted. (See FP-95 service manual for details.)

### **TO ADJUST SPEED ONLY**

Use the instructions TO PROGRAM ANY VARIABLE at the beginning of this procedure for general instructions on programming the ACS550 inverter.

**NOTE:** Only set these parameters if using a selector switch to set speeds; not if using a potentiometer. If using a potentiometer, the speed is varied with a 0 - 10 VDC signal into the inverter. The Group 12 parameters are not used with a potentiometer.

Press the MENU button.

Use arrows to access CHANGED PARAMETERS

1202	Const speed 1 (Speed 2)	<b>50 Hz (1000 RPM)</b>
1204	Const speed 3 (Speed 3)	<b>60 Hz (1200 RPM)</b>
1206	Const speed 5 (Speed 1)	<b>40 Hz (800 RPM)</b>

Push MENU until the display reads 0.0 Hz.

### **TO CALCULATE FREQUENCY FOR A DESIRED SPEED**

The output frequency of the inverter varies from 0 to 60Hz. This corresponds to speeds from zero to 1200 RPM.

The formula  $\text{DESIRED SPEED} / \text{MAXIMUM SPEED} \times 60 = \text{DESIRED FREQUENCY}$  provides the required output frequency for any desired speed. For example, if 900 RPM is desired, the formula becomes  $900 / 1200 \times 60$  which equals 45Hz. This can be programmed into any of the three preset speeds. (See previous step.)

## GLOSSARY

<u>Item</u>	<u>Part No.</u>	<u>Description</u>
Actuator	K-321	Lever on micro switch.
Adjusting screw	2256-B	Bolt in the lid lock lever used to keep the lid closed when the machine is in operation.
Ball cap	35880	Stainless steel cap on the top of the hex ball.
Basket	37230	Perforated stainless steel container inside the machine in which the material to be centrifuged is loaded.
Basket ball	31290	Cast iron hex shaped sleeve at top of the drive unit shaft on which the basket rests.
Bumper cap	2400-263	Cap used to hold the drive unit in hangers.
Cam	2253-B	Used to lock the lid closed when the machine is in operation. Located inside the control box and keyed to the hinge shaft.
Center post	33080	The dome shaped part at the center of the basket. The drive unit shaft extends into the center post for the purpose of driving the basket
Curb	32460	The outer shell of the machine in which the basket is housed.
Delay relay	24510	Solid state circuit used to allow voltage to be applied for a certain amount of time.
Lid lock assembly		The assembly of components used to keep the lid locked while the machine is in operation.
Lid hinge brake	2399-B	A split bushing located on the lid hinge shaft used to control the amount of friction on the lid hinge. This controls the positioning of the lid and keeps it from falling closed.
Proximity sensor	FP35-087	Device used to sense position of lid or lock.
Relay	26440	An electrical component having a coil and one or more contacts which are used to switch power on or off within an electrical circuit.
Solenoid	51290 or 37949	An electrical component used to actuate the lid lock device.
Skirt	35790	The machine base. Supports the trunnion ring and drive unit.

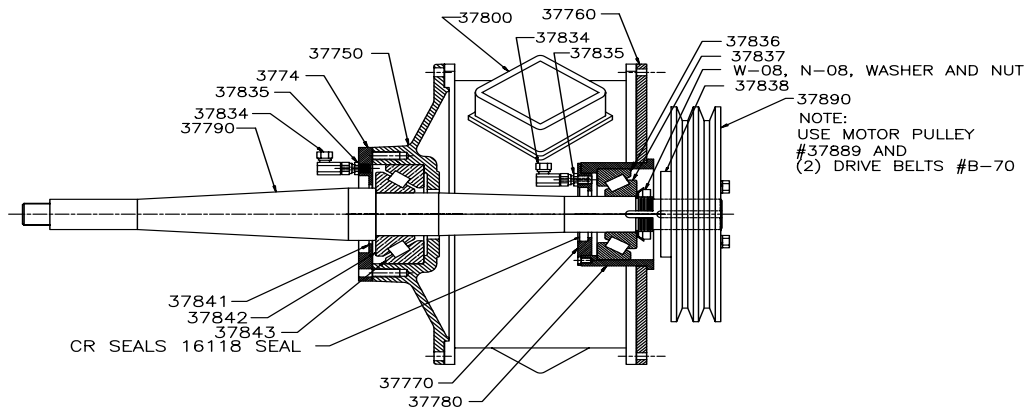

37730 DIRECT DRIVE UNIT ASSEMBLY

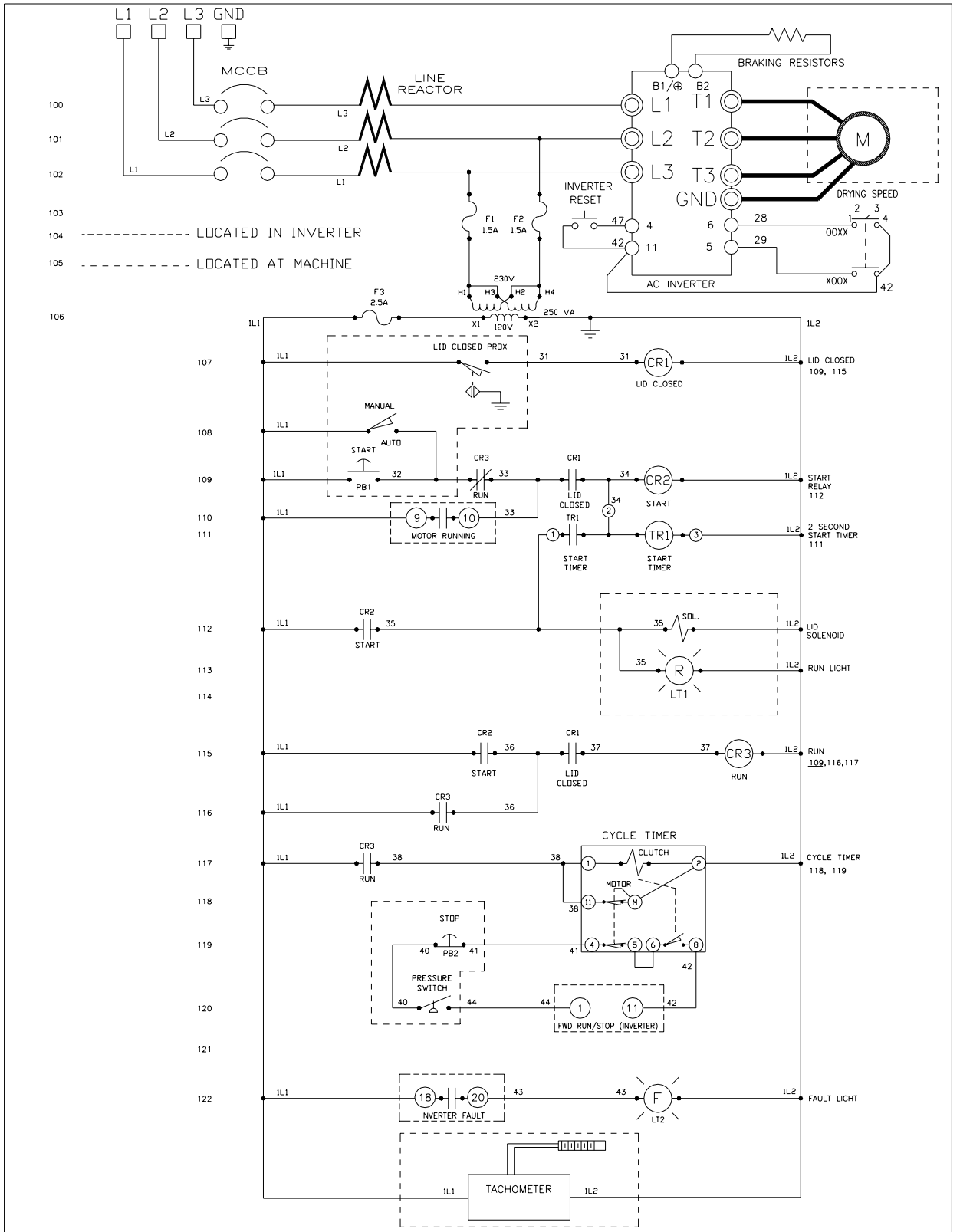

**FP-95 SCHEMATIC DIAGRAM  
(G5 INVERTER)**

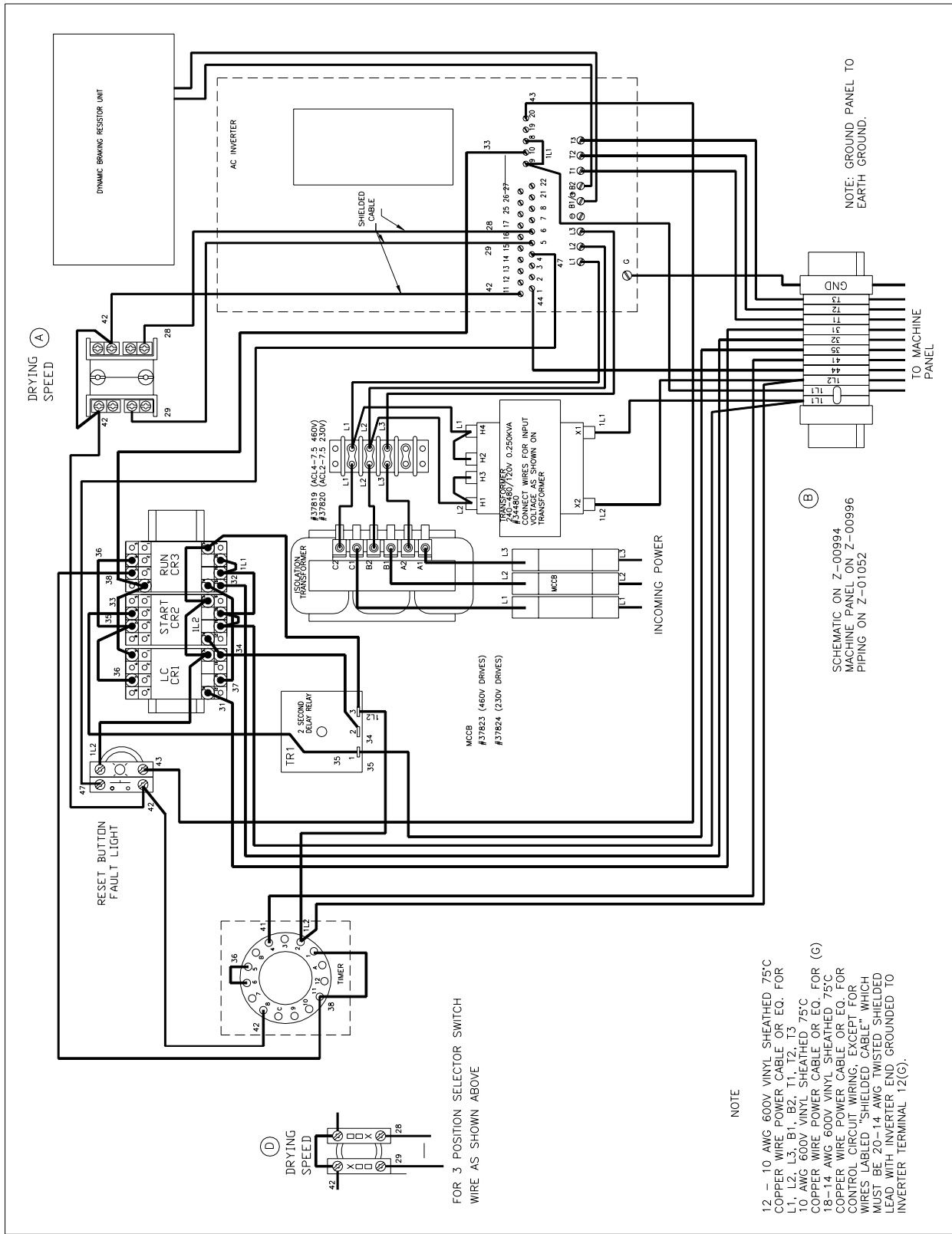

**FP-95 REMOTE PANEL WIRING DIAGRAM  
(G5 INVERTER)**

NOTE  
 12 - 10 AWG 600V VINYL SHEATHED 75°C COPPER WIRE POWER CABLE OR EQ. FOR L1, L2, L3, B1, B2, T1, T2, T3  
 10 AWG 600V VINYL SHEATHED 75°C COPPER WIRE POWER CABLE OR EQ. FOR 18-14 AWG 600V VINYL SHEATHED 75°C COPPER WIRE POWER CABLE OR EQ. FOR CONTROL CIRCUIT WIRING, EXCEPT FOR WIRES LABELED "SHIELDED CABLE" WHICH MUST BE 20-14 AWG TWISTED SHIELDED LEAD WITH INVERTER END GROUNDED TO INVERTER TERMINAL 12(G).

FOR 3 POSITION SELECTOR SWITCH WIRE AS SHOWN ABOVE

NOTE: GROUND PANEL TO EARTH GROUND.

SCHEMATIC ON Z-00994 MACHINE PANEL ON Z-00996 PIPING ON Z-01052



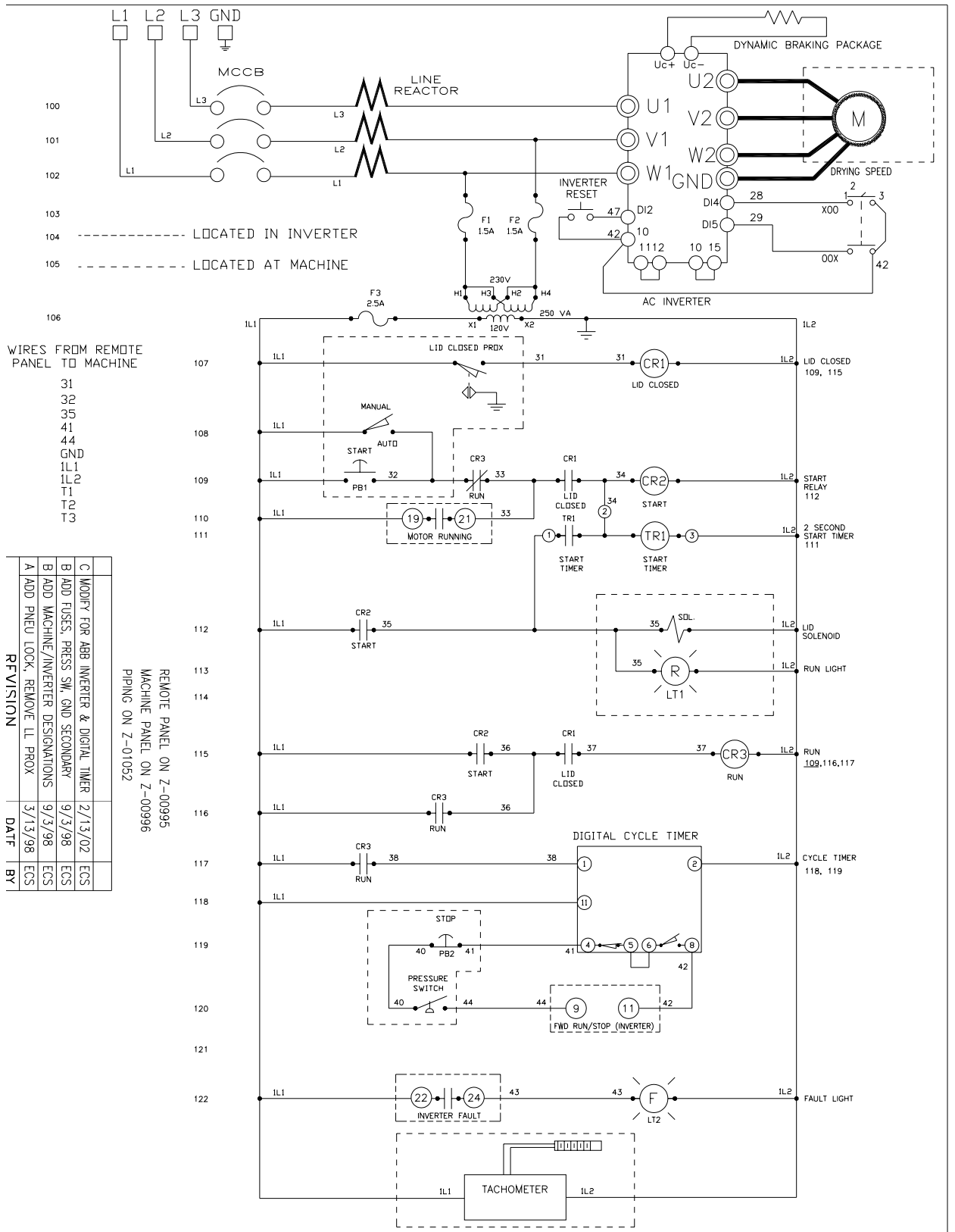

**FP-95 SCHEMATIC DIAGRAM  
(ACS400 & ACS550 INVERTER)**

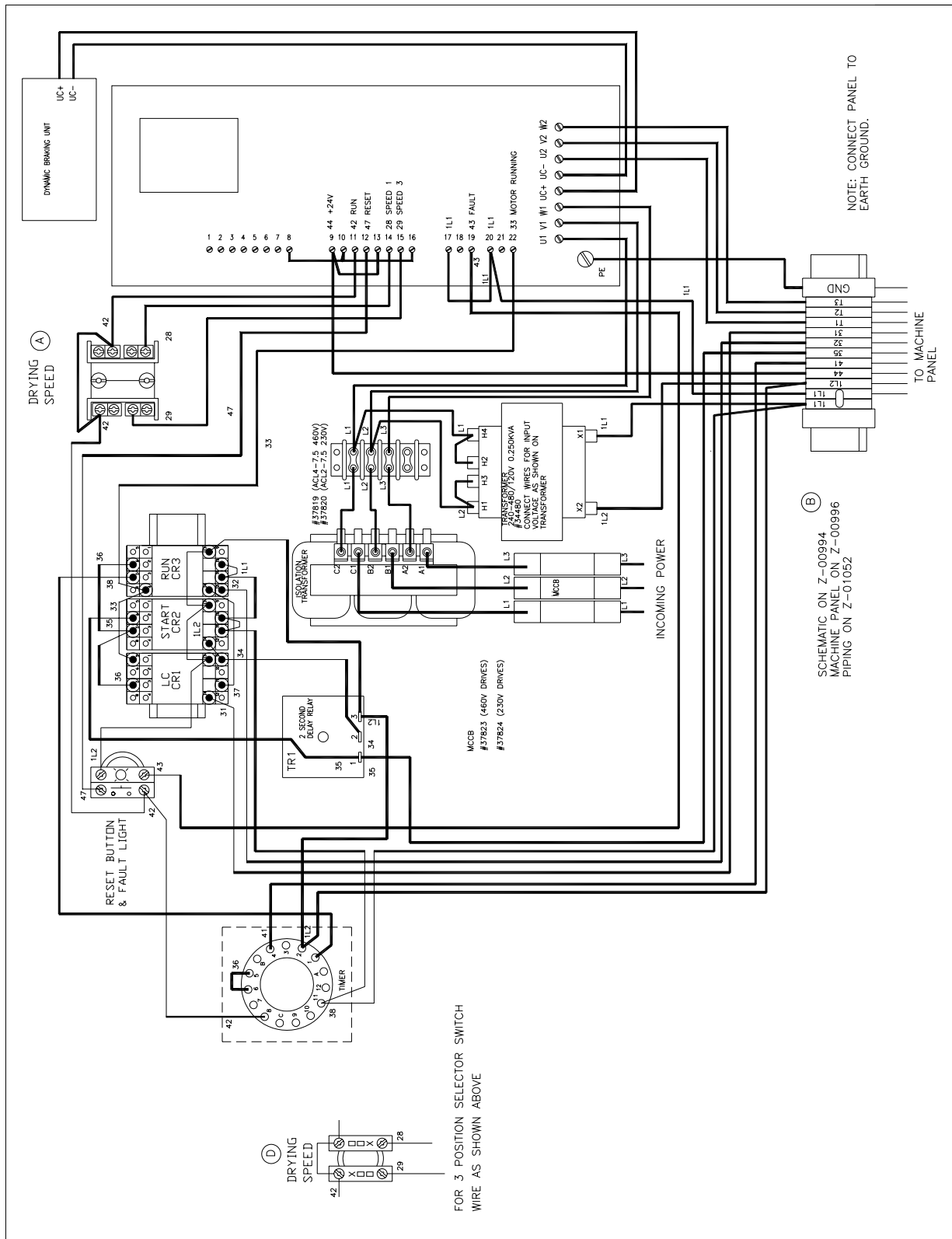

**FP-95 REMOTE PANEL WIRING DIAGRAM  
(ACS400 INVERTER)**

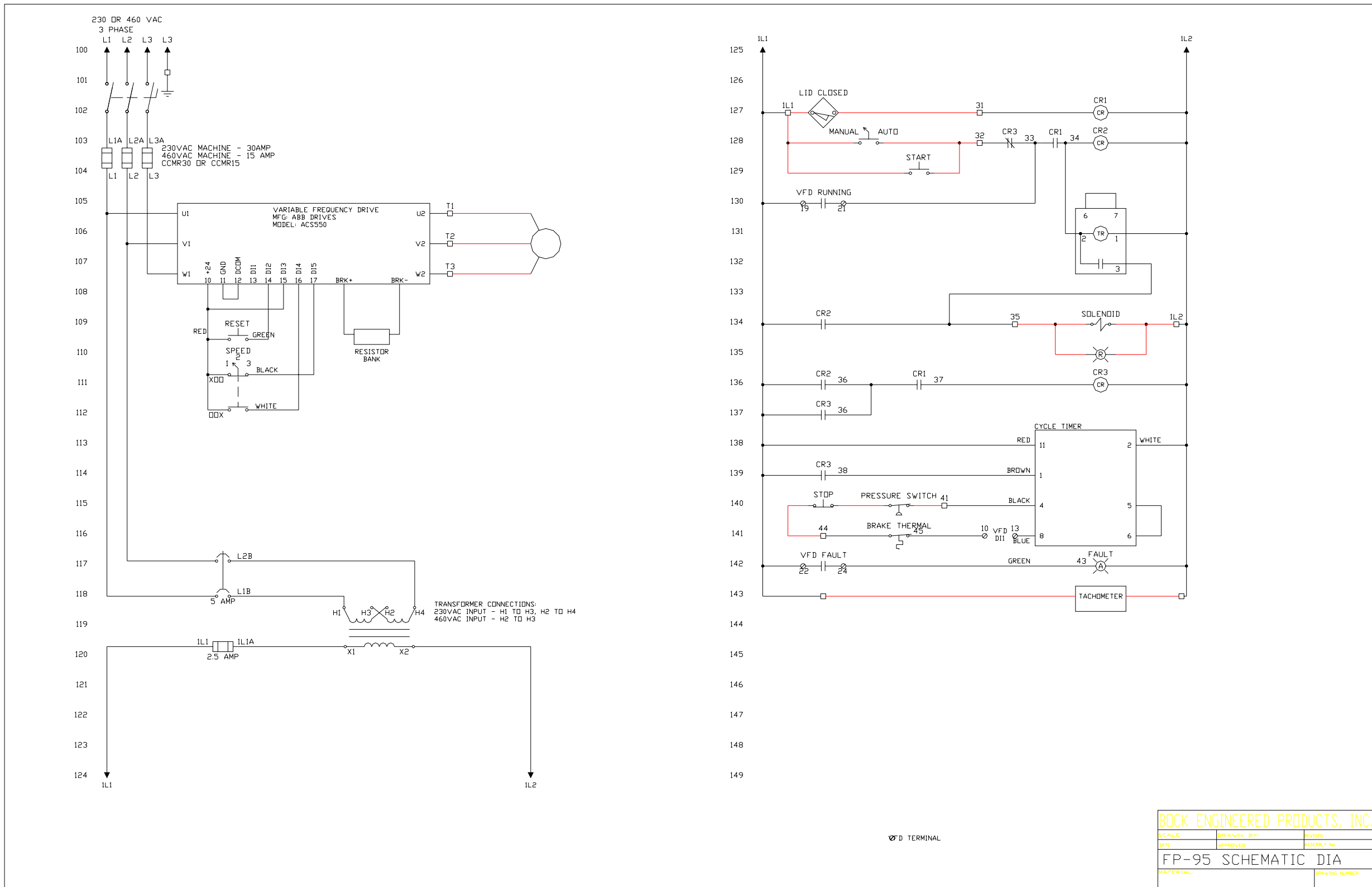

BOCK ENGINEERED PRODUCTS, INC.		
SCALE:	DRAWN BY:	REVISED:
DATE:	APPROVED:	ASSEMBLY No:
FP-95 SCHEMATIC DIA		DRAWING NUMBER:
MATERIAL:		

PLOTTED ON

**FP-95 SCHEMATIC DIAGRAM  
(ACS550 INVERTER)**



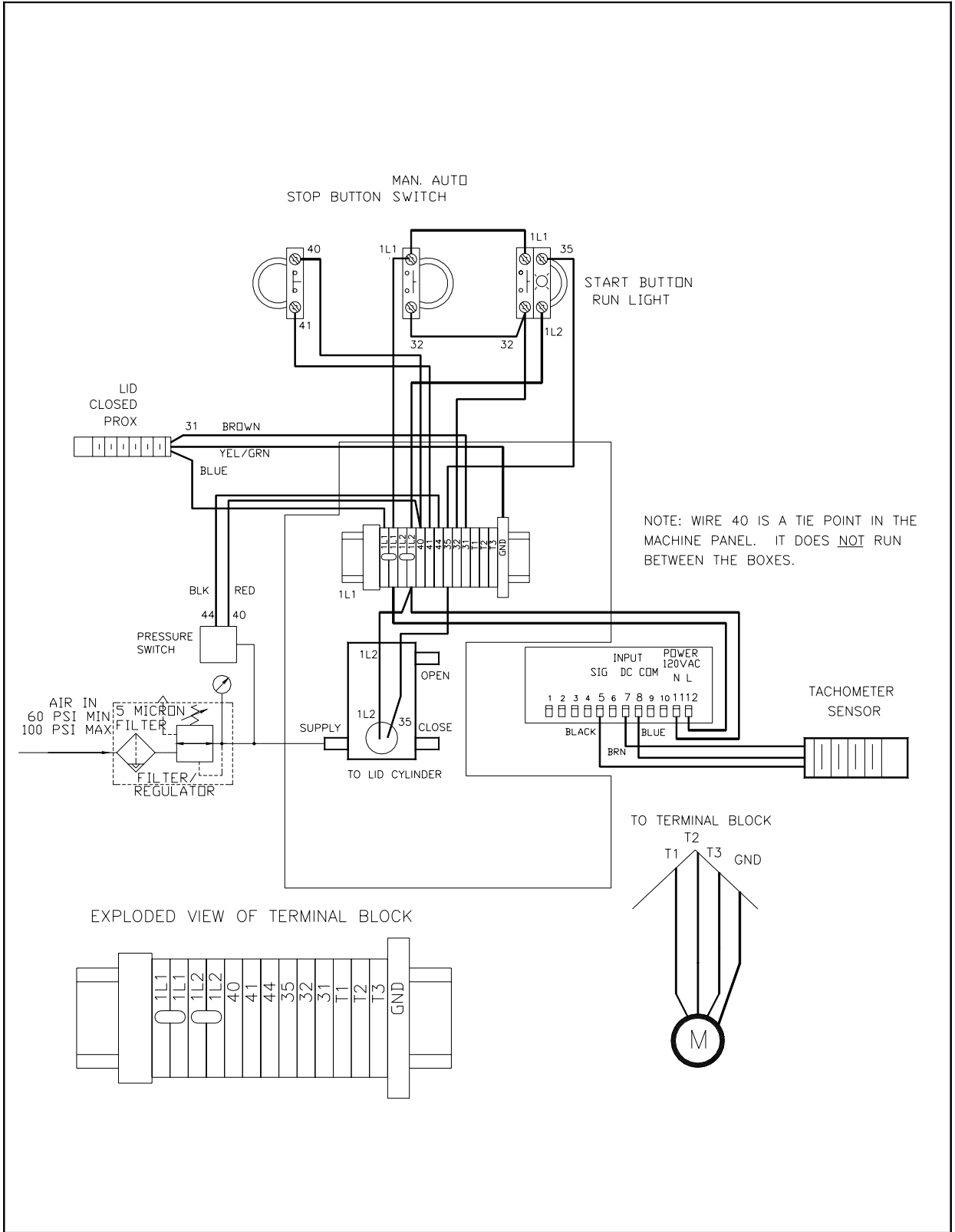

**MACHINE PANEL WIRING DIAGRAM**



**PARTS LIST  
MODEL FP-95 EVS DRIVE**

<b>NSEP PART #</b>	<b>DESCRIPTION</b>
B-69	DRIVE BELT (2 REQUIRED)
FP35-071	LAMP
FP35-087	PROXIMITY SENSOR
10340	TRUNNION RUBBER CAP
22020	MOTOR HANGER PIN
2253-B	LID LOCK CAM (3/4" BORE)
2254-1	LID LOCK LEVER
22560	ADJUSTING SCREW FOR 2254-1
2286-B	LID SAFETY CAM (3/4" SHAFT)
2291 SS	MACHINE CONTROL PANEL BACK COVER
23140	SNAP RING
23680	GREASE FITTING (HGF-2, 1/4-28 THREAD)
23980	ADJUSTING BOLT, LID HINGE BRAKE
2399-B	LID HINGE BRAKE (3/4" SHAFT)
2400-263	BUMPER RUBBER CAP
2400-285	TENSION SPRING
2400-293	TRUNNION RUBBER
2400-337	MOTOR HANGER
2400-444	BUMPER RUBBER
2400-472	TRUNNION FRAME ASSEMBLY
24470	ANALOG CYCLE TIMER (110 volts)
38098	DIGITAL CYCLE TIMER (110 volts)
24510	2 SECOND DELAY RELAY (120 volts)
25180	CONTROL PANEL PLATE
25680	COTTER PIN FOR THE 2569 CLEVIS PIN
25690	CLEVIS PIN FOR THE LID SOLENOID
26440	RELAY
26450	RELAY SOCKET
26460	RELAY HOLD DOWN CLIP
28130	CONTROL RELAY
2958A	LID LOCK CAM (3/4" SHAFT)
29640	LIGHTED EMERGENCY STOP BUTTON
31290	BASKET BALL (W/STAINLESS STEEL CAP)
31490	LID HINGE FRAME
31680	GASKET (CURB TO SKIRT LEG)

32080	HINGE SHAFT (3/4" DIA. W/SQ. KEY, WASHERS AND BOLTS)
32090	LID SOLENOID LINK
3215-3	5 HP MOTOR ASSY. 240v. (W / PULLEY AND HUB, 1 1/8" SHAFT)
3215-4	5 HP MOTOR ASSY. 460v. (W / PULLEY AND HUB, 1 1/8" SHAFT)
3243-SS	BASKET DOLLY FOR BASKET
32460	CURB ASSEMBLY
32650	LID BUMPER ANGLE
32760	LID BUMPER
32960	BASKET LIFTING YOKE ASSEMBLY
33080	CENTER POST
33180	RETURN SPRING (LID SOLENOID)
33510	MACHINE LID
34140	LID SOLENOID
34860	GAS SPRING BOX BRACKET
34950	BALL STUD (FOR #3484)
34960	RETAINING CLIP (FOR #3495)
35790	SKIRT WELDMENT
35880	BALL CAP, STAINLESS STEEL
36040	AIR REGULATOR
36860	LID HANDLE
37230	STD. TOP BASKET ASSEMBLY (30" DIA. x 18" HIGH)
37400	MOTOR BASE BRACKET
37730	DIRECT DRIVE UNIT ASSEMBLY
37750	TOP END PLATE
37760	BOTTOM END PLATE
37770	BOTTOM SEAL CAP
37780	BEARING HOUSING
37790	DIRECT DRIVE SHAFT
37800	UNIT HOUSING
37814	REMOTE ELECTRICAL PANEL SUBASSEMBLY (460V.)
37815	REMOTE ENCLOSURE W/PANEL
37816	REMOTE BACK PANEL
37817	AC INVERTER G5 STYLE (460 v.)
37818	AC INVERTER G5 STYLE (230 v.)
37819	ISOLATION TRANSFORMER (LINE REACTOR) (460 v.)
37820	ISOLATION TRANSFORMER (LINE REACTOR) (230 v.)



37823	CIRCUIT BREAKER 20 A.
37825	POTENTIOMETER (2K)
37827	REMOTE ENCLOSURE (BRAKING RESISTOR)
37828	BRAKE BACK PANEL
37829	POTENTIOMETER (2.5 K)
37830	LEGEND PLATE (0-100% SPEED)
37831	RESET PUSH BUTTON
37832	LEGEND PLATE (RESET)
37834	SWIVEL ADAPTER (90 DEGREE)
37835	SWIVEL ADAPTER (STRAIGHT)
37836	LOWER BEARING CUP
37837	LOWER BEARING CONE
37838	PULLEY HUB (1 3/8" BORE)
37840	LOWER SEAL
37841	UPPER SEAL
37842	UPPER BEARING CONE
37843	UPPER BEARING CUP
37844	GREASE HOSE (15")
37845	GREASE FITTING BLOCK
37889	MOTOR PULLEY (DOUBLE "V" BELT)
37890	DRIVE UNIT PULLEY (DOUBLE "V" BELT)
37910	BRAKING RESISTORS (460 v.)
37911	BRAKING RESISTORS (230 v.)
37916	TACHOMETER
37917	TACHOMETER SENSOR
37918	CHECK VALVE
37923	LID STRUT (AIR CYLINDER)
37926	MANUAL/AUTO SWITCH ASSEMBLY
37927	RESET BUTTON ASSEMBLY
37928	SPEED SELECTOR SWITCH ASSEMBLY
37929	START SWITCH ASSEMBLY
37930	STOP SWITCH ASSEMBLY
37949	LID LOCK SOLENOID VALVE (115 V)
5416	TERMINAL BLOCK

## RECOMMENDED SPARE PARTS FOR FP-95

P/N	DESCRIPTION	QUANTITY
B-69	V-BELTS	2
FP35-071	LAMP	2
FP35-087	PROXIMITY SENSOR	1
24470	ANALOG CYCLE TIMER	1
38098	DIGITAL CYCLE TIMER	1
24510	2 SECOND DELAY	1
28130	CONTROL RELAY	3
31290	BASKETBALL	1
37949	LID SOLENOID	2
36040	AIR REGULATOR	1
37836	LOWER BEARING CUP	1
37837	LOWER BEARING CONE	1
37840	LOWER BEARING SEAL	1
37841	UPPER BEARING SEAL	1
37842	UPPER BEARING CONE	1
37843	UPPER BEARING CUP	1
37918	CHECK VALVE	1
37923	LID STRUTS (AIR CYLINDERS)	2
37926	MANUAL/AUTO SWITCH ASSY	1
37927	RESET BUTTON ASSY	1
37928	SPEED SELECTOR SWITCH ASSY	1
37929	START SWITCH ASSY	1
37930	STOP SWITCH ASSY	1

### OPTIONAL PARTS

37817	INVERTER G5 (380-460 V OPERATION)	1
37818	INVERTER G5 (230 V OPERATION)	1
38103	INVERTER ACS400 (208-240 V OPERATION)	1
38104	INVERTER ACS400 (380-460 V OPERATION)	1
38165	INVERTER ACS550 (208-240 V OPERATION)	1
38166	INVERTER ACS550 (380-460 V OPERATION)	1



**Glassline Corporation**  
28905 Glenwood Road, P.O. Box 147  
Perrysburg, OH 43552-0147

Phone: 419/666-5942  
Fax : 419/666-1549  
[www.glasslinecompanies.com](http://www.glasslinecompanies.com)

## GENERAL TERMS AND CONDITIONS OF SALE

This agreement sets forth general terms and conditions of sale. The quotation and sales contract may incorporate additional and more specific commercial and technical requirements of sale. The following general terms and conditions are mutually agreed between BUYER and GLASSLINE to be a part of the sales and purchase order documents.

### **1. DEFINITIONS AND GENERAL TERMS AND CONDITIONS**

- A. The term GLASSLINE shall refer to Glassline Corporation and all of its affiliated divisions.
- B. The term EQUIPMENT shall refer to any machine, part, product or service sold by GLASSLINE, including subcontracted/purchased items/options.
- C. The term BUYER shall refer to the buying company and, where applicable, its subcontractors.
- D. The terms and conditions set forth in this agreement are effective at the receipt of order by BUYER and are subject to change by GLASSLINE without notice before receipt of order by Buyer.
- E. Quotations are valid for 30 days, unless noted otherwise.
- F. No terms, conditions, understandings, usage of trade, dealings or agreements, purporting to vary, modify, explain or supplement this agreement shall be binding, unless and until hereinafter made in writing and signed by BUYER and GLASSLINE.
- G. This agreement, and its interpretation, shall be governed by the laws of the State of Ohio. If any provision or term of this agreement is held to be invalid, void or unenforceable, the remaining provisions and terms of the agreement shall remain in force and effect, and shall in no way be affected, impaired or invalidated thereby. In all cases, the rights and duties of the parties in a dispute arising out of this transaction shall be governed by the laws of the State of Ohio.
- H. The delegation or assignment by BUYER of any or all of its duties or rights under this agreement without the prior written consent of GLASSLINE shall be void.
- I. Any information, suggestions or ideas transmitted by BUYER or GLASSLINE, or any of their respective representatives, in connection with the performance under this agreement are not to be regarded as secret or submitted in confidence, except as may be otherwise provided specifically in a document signed by a duly authorized representative of GLASSLINE.
- J. This agreement supersedes all previous agreements, written or verbal, and contains the entire agreement between the parties.

### **2. TERMS AND CONDITIONS OF BUYER**

Should BUYER have standard terms of acceptance that it wishes to make a part of this agreement, such terms must be provided at the time a quotation is requested and agreed to in writing by GLASSLINE, so that the costs of compliance to such terms as GLASSLINE may agree, if any, may be added to the bid. GLASSLINE reserves the right to quote these compliance features separately and above their standard quotation.

### **3. DELIVERY AND CLAIMS**

- A. The quoted shipment schedule is non-binding. The shipment schedule will be set at time of order, and is contingent upon BUYER supplying a clear scope of supply, all technical information, and any required downpayment. A new delivery date may be required, depending on any technical or scope changes requested after the order date, or delays in receiving payments according to agreed dates.
- B. GLASSLINE shall not be liable for delays in delivery caused by any reason beyond GLASSLINE's control, including, but not limited to, force majeure, supplier failure, any interruption of GLASSLINE facilities, or any act of any government, or licensing authority.
- C. Unless otherwise noted in the quotation, all shipments are ex-works GLASSLINE Perrysburg, Ohio plant. BUYER bears all risks of loss or damage to the EQUIPMENT from the time the EQUIPMENT has been placed at the disposal of Buyer at GLASSLINE, whether shipping is arranged by BUYER or on behalf of BUYER by GLASSLINE. In any case, shipments shall be made strictly according to Incoterms 2000.
- D. After the EQUIPMENT is placed at the required transfer point for BUYER, GLASSLINE neither assumes responsibility for nor authorizes any expenses, including electrical work, plumbing, compressed air supply, millwright work, extensions/additions, or materials necessary for the set up and operation of the EQUIPMENT in BUYER's plant or elsewhere. It remains the BUYER's responsibility to meet all federal, state and local codes and regulations.
- E. Claims for shipping damage, concealed or otherwise, are the responsibility of BUYER and should be taken up with the delivering carrier within the stated time allowed for claims. Claims for shipping shortages will not be allowed, unless reported to GLASSLINE within 10 days of shipment.

### **4. TITLE**

- A. Title to the EQUIPMENT, thus delivered, shall remain with GLASSLINE; until the full purchase price has been received.
- B. BUYER shall keep the EQUIPMENT fully insured, with GLASSLINE named as loss payee until the purchase price is paid. Neither BUYER nor GLASSLINE shall assign the applicable insurance contact without prior written consent of the other.
- C. Monthly interest, at the rate of 1-1/2% per month on the total unpaid value of the EQUIPMENT will be charged if delivery is delayed at BUYER's request for more than thirty (30) days after buy-off, or if final payment is delayed beyond thirty days (30) after shipment. BUYER shall execute and deliver to GLASSLINE such documents and financial statements as may be necessary to perfect the lien or security interest of GLASSLINE to protect the unpaid balance of the purchase price.

- D. All tools, materials, software, programs, designs, or any technology created for the purpose of producing the EQUIPMENT are the sole property of GLASSLINE, unless furnished by BUYER with the order. All intellectual property created by GLASSLINE shall remain property of GLASSLINE.

**5. WARRANTY**

- A. GLASSLINE warrants against defects in material and workmanship. Items manufactured by others but installed in or affixed to GLASSLINE EQUIPMENT are not warranted by GLASSLINE, but bear only such express warranties, if any, of the manufacturer thereof. GLASSLINE shall replace or repair at its choosing, (ex-works GLASSLINE Perrysburg, Ohio plant) any defective manufactured parts without charge to BUYER. The warranty does not apply to any labor charges for removal and/or replacement, or to any part thereof which has a life, under normal usage, inherently shorter than the warranty period. The warranty will be active for a period of:
  - 1) Machinery: 12 months from date of shipping.
  - 2) Replacement/Repaired parts: 6 months from date of shipping.
- B. Warranty shall be deemed waived by BUYER if:
  - 1) The EQUIPMENT is not properly installed by BUYER, according to GLASSLINE installation instructions.
  - 2) The EQUIPMENT has been subjected to misapplication or misuse, neglect, damaging conditions, or is modified in any way without written approval by GLASSLINE.
  - 3) The production or use of the EQUIPMENT for which it was not intended, or on products out of specification.
- C. The warranty set forth herein is in lieu of all other warranties, whether express, implied or statutory, including those of merchantability and fitness of any product for a particular purpose, and of any other obligation or liability on GLASSLINE's part of any kind or nature whatsoever.
- D. The warranty granted herein is non-transferable, and is granted only to the original BUYER.
- E. No employee, agent or other representative has any authority to waive, alter, vary or add to the terms hereof without prior approval in writing, signed by an officer of GLASSLINE.

**6. LIMITATION OF LIABILITY**

- A. It is expressly understood that GLASSLINE's liability for any damages arising out of or related to this transaction, or for its EQUIPMENT, whether in contract or in tort, is limited to the repair or replacement of the parts thereof as stipulated in the warranty, and is not to exceed the contract price in respect to which the claim is made.
- B. BUYER is solely responsible for ensuring the safety of all personnel who may be in close proximity to the EQUIPMENT.
- C. GLASSLINE will not be liable for any other injury, loss, damage or expense, whether direct, incidental or consequential, including but not limited to labor, loss of use, downtime, loss of material, products income, profit or production, or increased cost of operation, or spoilage of damage to material, arising in connection with the sale, installation, use of, or inability to use, or the repair or replacement of, or late delivery of, GLASSLINE EQUIPMENT.
- D. BUYER shall indemnify, defend and hold harmless GLASSLINE and its directors, officers, agents and employees, against any and all demands, claims, actions, damages, liabilities, costs, expenses (including reasonable attorney fees and expenses) and other losses of any kind whatsoever, whether based upon theories of contract, tort, negligence, strict liability, warranty, indemnification, contribution, statute or otherwise, for personal injury or property damage caused by BUYER or by any of its directors, officers, agents, employees or subcontractors, arising out of or relating to the Equipment Buyer shall give GLASSLINE prompt written notice of any such matters and the full opportunity to defend itself against them. This indemnity of BUYER shall survive the termination of this agreement.
- E. The remedies and limitations set forth in this agreement are the exclusive remedies for claims based upon any defect in or failure of EQUIPMENT, whether products or services, whether such claims are presented in contract or in tort (including negligence) and however and wherever instituted. Upon the expiration of the warranty period, all such liability shall terminate.

**7. ORDER ACCEPTANCE**

GLASSLINE reserves the right to refuse any order. An order shall be deemed accepted and a binding contract formed when the initial payment has been received and the order is acknowledged in writing by GLASSLINE.

**8. CANCELLATION BY BUYER**

BUYER may cancel the order for all or any EQUIPMENT by written notice prior to shipment. GLASSLINE will stop work on the order as soon as possible after receipt of written cancellation. BUYER agrees to pay GLASSLINE for all costs incurred by GLASSLINE and/or other suppliers attributed to the order, including but not limited to components, work-in-process, labor, burden and overhead. Such payment will not transfer title to BUYER.

**9. ARBITRATION AGREEMENT**

Any controversy or claim arising out of or relating to this agreement, or the breach thereof, shall be settled by arbitration in accordance with the rules of the American Arbitration Association and the statutes of the State of Ohio. All hearings held in connection with any such arbitration shall be held in Toledo, Ohio (unless the parties agree otherwise in writing), the award of the arbitrator(s) shall be final and binding upon the parties, and the judgment upon and the award rendered by the arbitrator(s) may be entered in any court having jurisdiction thereof.