

From: [Scott Roda](#)
To: [Bahn, Duane](#)
Cc: [Sanford, John](#); [Kirby, Lisa](#)
Subject: New Generator Quote at the Dallastown High School Football Stadium
Date: Thursday, June 12, 2014 2:26:09 PM
Attachments: [RS25spec.pdf](#)
Importance: High

Duane – In the essence of time I want to email you the finalized quote now so you have it for the board meeting tonight. I will email you the actual sales agreement once you determine to move forward, but this is the actual finalized quote and includes all materials, rentals, installation by the electrician as well as the startup and training by DynaTech. It does not include the LP tank, fuel and fence around generator. It also does not include any state tax. It is priced using the COSTARS limitations and requirements.

- *New Cummins Onan RS25;(25kW Liquid Cooled; 1800 RPM; LP fueled Generator)
 - *Installation, Startup and Training
 - *Spec Sheets attached
 - *Single Phase
 - *Precast Concrete Pad (4' X 8') to Set Generator On
 - *1 Cutler Hammer Automatic Transfer Switch (2 Pole; 200 AMP) & Installation
 - *Installation and Materials for one (1)200 AMP Emergency Panel
 - *Relocate five (5) Existing Circuits to New Emergency Panel
 - *Provide Trenching, Backfill and Reseeding for Generator Control Wiring Conduits
 - *Provide Materials and Labor for Electrical Connections to Generator, Automatic Transfer Switch and New Emergency Panel
-
- *Total Price - \$27,950

Thanks, Scott.

Scott Roda | Power Specialist
Office: 800.779.8809 Ext. 212 | Mobile: 717.468.9721
Fax: 717.274.8934
[DynaTech Generators](#) - Delivering Power and Confidence

- Design | Build | Install
- New and Reconditioned Equipment
- Generator and Load Bank Rentals
- Load Banking | Preventative Maintenance | Fuel Polishing
- COSTARS # 008-277 | HIC # PA 011474

Quiet Connect™ Series RS25



Features and benefits

Robust product design and testing - The generator is designed to operate under extreme environmental conditions including cold weather starts at as low as -40 °F. The generator is tested and certified per the latest EPA, UL and IBC Seismic standards and is capable of meeting NFPA110 requirements when equipped with the necessary accessories and properly installed.

Flexible Exercise mode - The innovative, flexible exercise mode enables the generator to exercise at a time, frequency and duration that suits the customer's preference - as little as 2 minutes every 6 months - reducing unnecessary fuel consumption, emissions and noise.

Advanced Enclosure Design - The aesthetically appealing enclosure incorporates special designs that deliver one of the quietest generators of its kind. Aluminum material plus durable powder coat paint provides the best anti-corrosion performance. The robust design is capable of withstanding winds up to 150 MPH and the intelligent design has removable panels and service doors to provide easy access for service and maintenance.

Self diagnostics and easy service - The generator is equipped with Cummins PowerCommand electronic control to provide industry-leading self diagnostic capabilities. In addition, critical components of the generator are designed to ensure service and preventive maintenance can be completed in a short period of time.

Weight, size and sound level

Weight: 1109 lbs (503 kg)

Size: Length 72 in (1829 mm), width 34 in (864 mm), height 45.5 in (1156 mm)

Sound: 64 dB(A) at 23 ft (7 m) with sound level 2 enclosure

Series	Model	Phase	Voltage (V)	Frequency (Hz)	Rated amps ¹ (NG/LPV fuel)	Circuit breaker (Amps)
RS25	C25 N6	1	120/240	60	104.2/104.2	125
		3	120/208	60	86.7/86.7	100
		3	120/240	60	75.2/75.2	90

¹ Derating guidelines: Natural Gas: Engine power available up to 0m (0 ft) at ambient temperatures up to 25 °C (77 °F). Above these elevations derate at 4% per 305m (1000 ft) and 2% per 10 °C above 25 °C (77 °F).

Propane: Engine power available up to 114m (375 ft) at ambient temperatures up to 25 °C (77 °F). Above these elevations derate at 4% per 305m (1000 ft) and 2% per 10 °C above 25 °C (77 °F).

Product features

Engine

- Natural gas/propane 1800 rpm engine
- Engine air cleaner – normal duty
- Electronic governor, isochronous
- Engine starter, 12 VDC motor
- Shutdown – low oil pressure
- Extension – oil drain
- Engine oil

Fuel System

- Single fuel – natural gas or propane vapor, field selectable

Alternator

- 60 Hz, 1 phase, 4 lead, or 3 phase, 12 lead, 120 °C temperature rise at 40 °C ambient
- Exciter/voltage regulator – torque match

Control

- PowerCommand 1.1
- Display language – English
- Control mounting, right facing

Electrical

- Single circuit breaker, UL certified, right-side mounted
- Battery charging alternator, normal duty
- Battery charger – 5 Amp, regulated

Cooling

- Generator set cooling capability – 50 °C
- Shutdown – low coolant level
- Engine coolant – 50/50 mixture
- Extension – coolant drain

Enclosure

- Aluminum enclosure Sound Level 1 with muffler installed, sandstone color
- Wind rating – 150 MPH

Code compliance

- UL 2200
- EPA emissions, emergency, stationary, 40CFR60
- IBC Seismic
- NFPA110 capable

Generator set application

- Coolant heater
- Battery rack
- Flexible fuel line
- Literature (English) – operator's manual, installation quick guide and manual, service manual

Warranty

- Base warranty – 2 year standby
- Extended warranties available

Packaging

- Shipping pallet, poly bag

Generator set performance

Governor regulation class: ISO 8528 Part 1 Class G3

Voltage regulation, no load to full load: ±1.0%

Random voltage variation: ±1.0%

Frequency regulation: Isochronous

Random frequency variation: ± 0.25% @ 60 Hz

Radio frequency emissions compliance: Meets requirements of most industrial and commercial applications

Engine

Design: Naturally aspirated

Bore: 86.5 mm (3.4 in)

Stroke: 100.0 mm (3.94 in)

Displacement: 2.4 liters (143.5 in³)

Cylinder block: Cast iron, in-line 4 cylinder

Battery capacity: 550 amps at ambient temperature of 0 °F to 32 °F (-18 °C to 0 °C)

Battery charging alternator: 50 amps

Starting voltage: 12 volt, negative ground

Lube oil filter type(s): Spin-on with relief valve

Standard cooling system: 50 °C (122° F) ambient cooling system

Rated speed: 1800 rpm

Fuel supply pressure

Minimum fuel supply pressure, kPa

(in H₂O): 1.5 (6.0)

Maximum fuel supply pressure, kPa

(in H₂O): 3.5 (14.0)

Control system

The PowerCommand® electronic control is standard equipment and provides total generator set system integration including automatic remote starting/stopping, precise frequency and voltage regulation, alarm and status message display, output metering, auto-shutdown at fault detection and NFPA 110 Level 1 compliance.

Sound attenuated enclosure

The aesthetically appealing enclosure incorporates special designs that deliver one of the quietest generators of its kind. Aluminum material plus durable powder coat paint provides the best anti-corrosion performance. The robust design is capable of withstanding winds up to 150 MPH and the intelligent design has removable panels and service doors to provide easy access for service and maintenance.

Average fuel consumption

Fuel consumption – natural gas

Load:	1/4	1/2	3/4	Full
Ft ³ /hr:	123.8	185.7	247.6	309.5
M ³ /hr:	3.5	5.2	6.9	8.7

Fuel consumption – LP vapor

Load:	1/4	1/2	3/4	Full
Ft ³ /hr:	51.6	75.6	99.6	125.4
M ³ /hr:	1.4	2.1	2.8	3.5
Gal/hr	1.4	2.1	2.8	3.5

Conversion factor:

8.58 ft³ = 1 lb

0.535m³ = 1 kg

36.39 ft³ = 1 gal

Easy service and installation

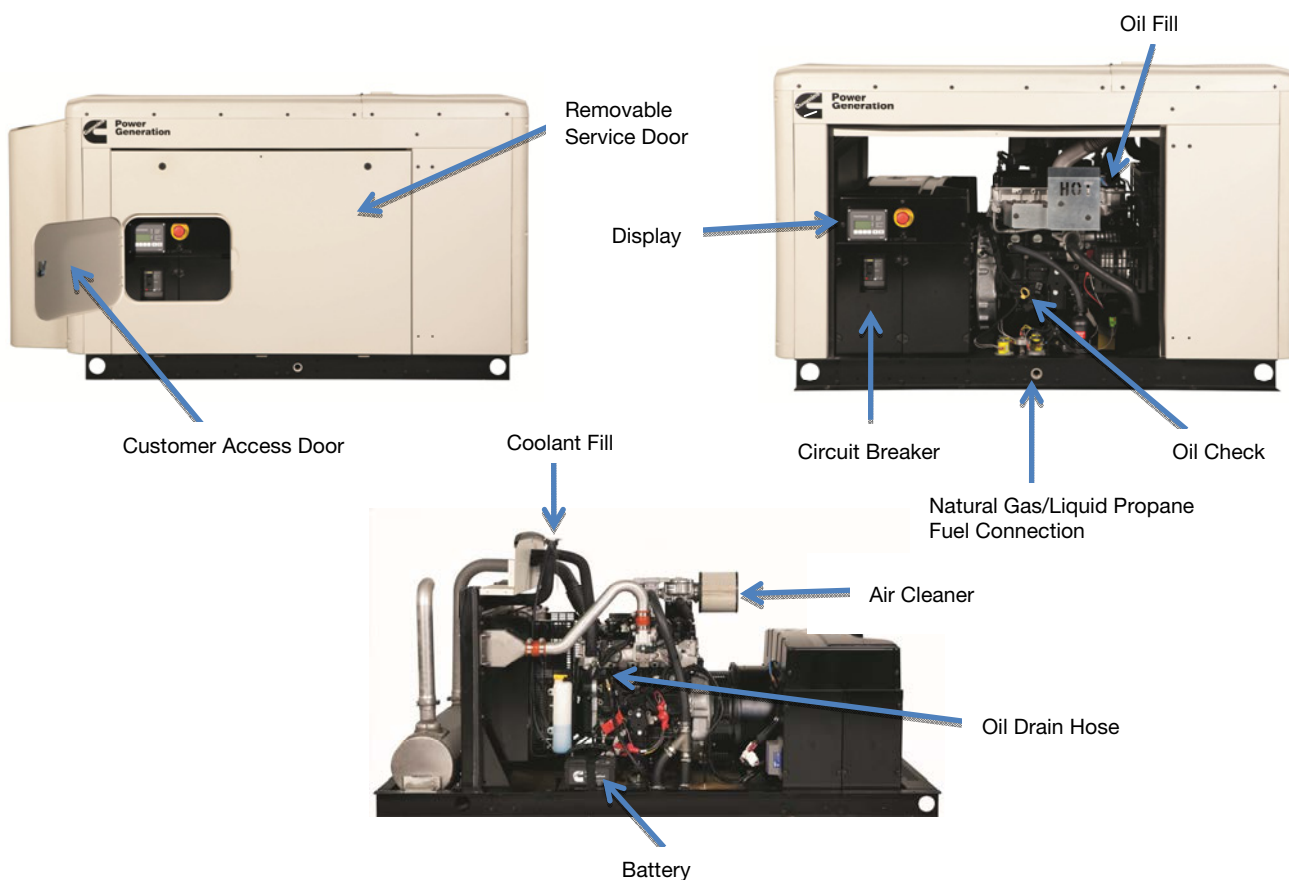

Our energy working for you.™

©2014 Cummins Inc. | NAS-5775b-EN (1/14)

power.cummins.com

Basic dimensions

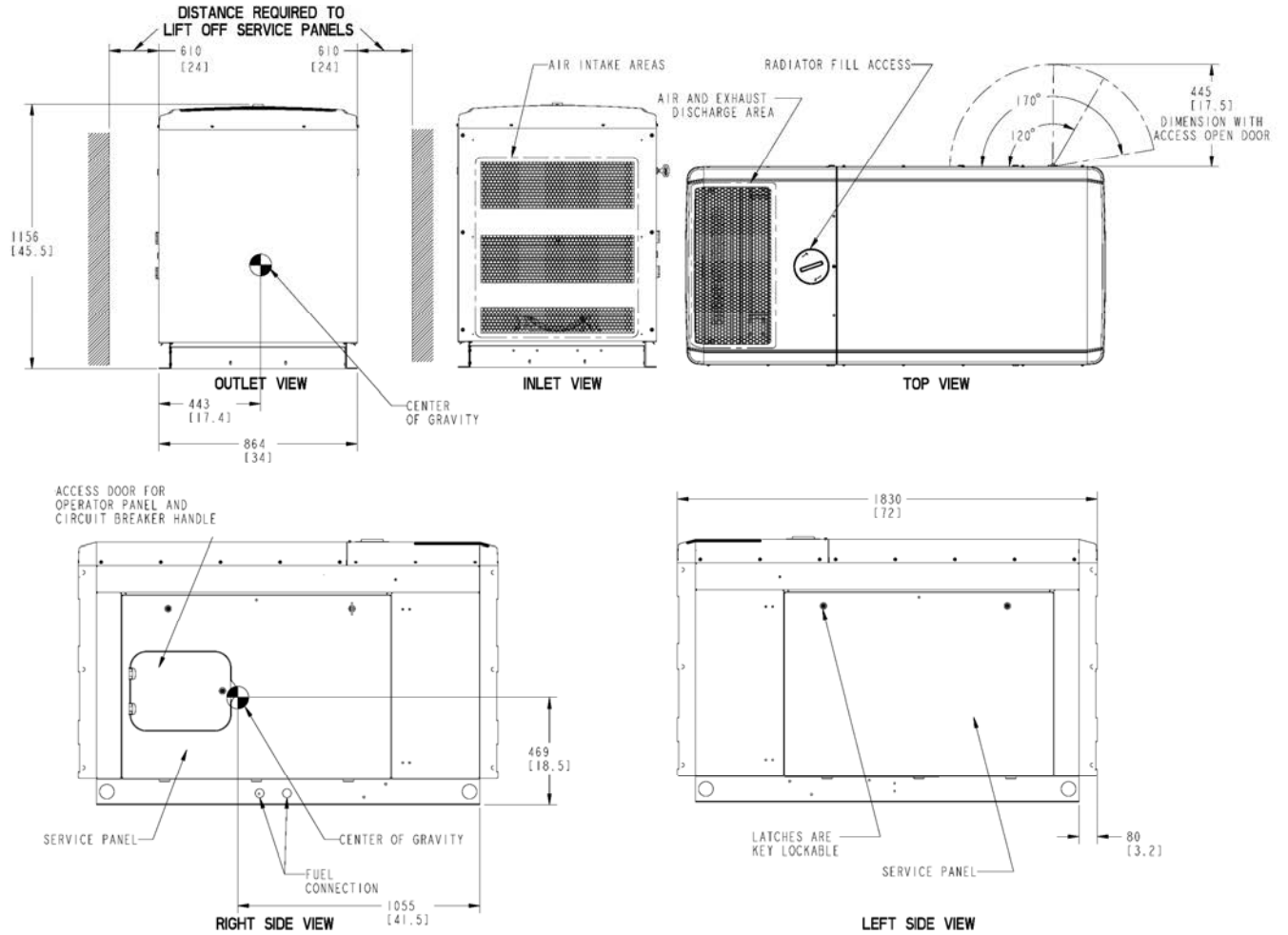

Note: This outline drawing is provided for general reference only and is not intended for use in design or installation. For more information, see Operators and Installation manuals or contact your distributor or dealer for assistance.

Automatic transfer panel configurations

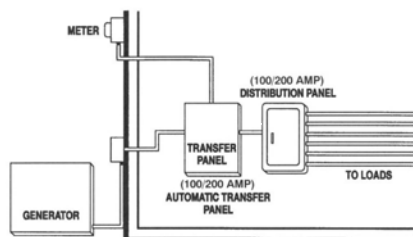

Typical service entrance ATS model installation (100/200A)

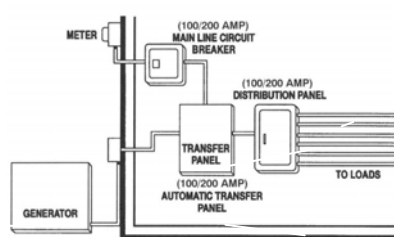

Typical non-service entrance ATS model installation (100/200A)

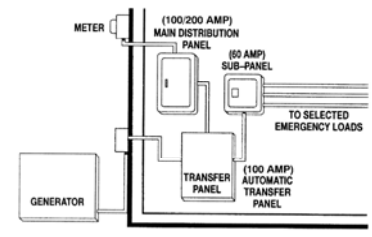

Dedicated emergency standby service system (100/200A)

Our energy working for you.™

©2014 Cummins Inc. | NAS-5775b-EN (1/14)

power.cummins.com

100A Non-service entrance

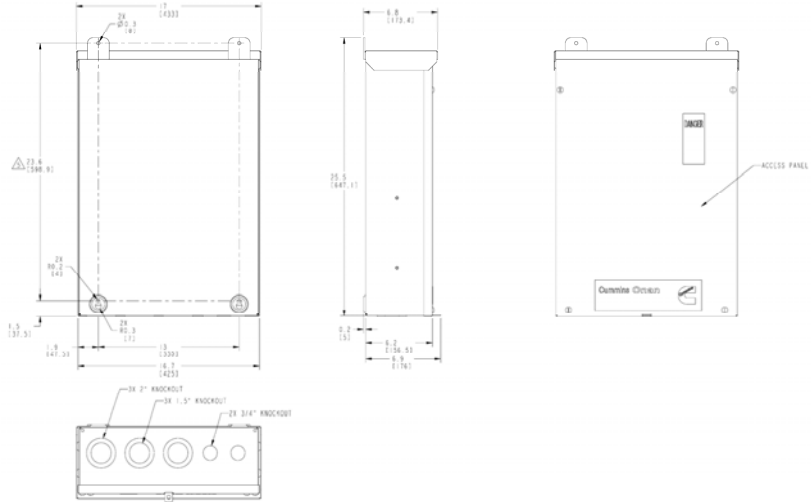

200A Non-service entrance

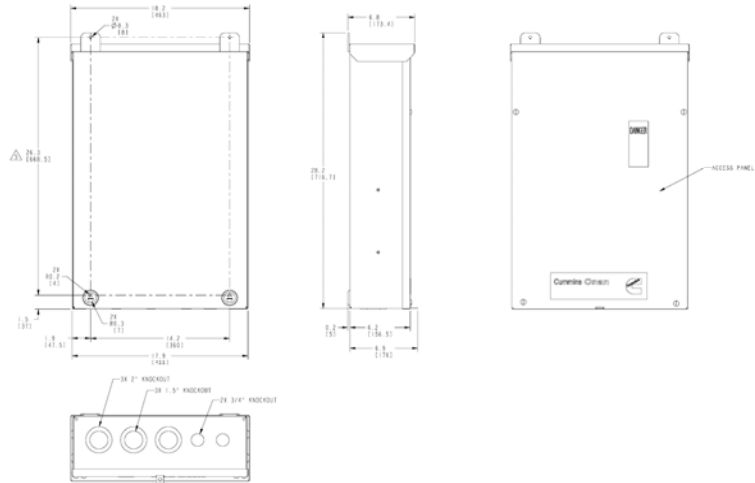

100A and 200A Service entrance

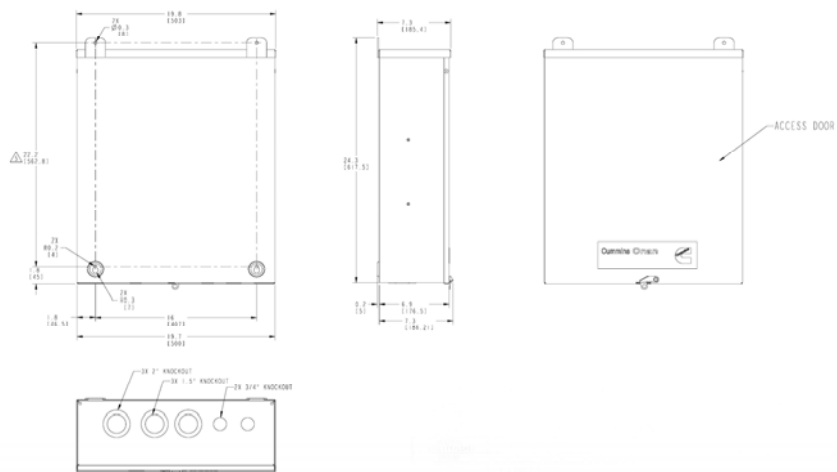

Our energy working for you.™

©2014 Cummins Inc. | NAS-5775b-EN (1/14)

power.cummins.com

Accessories

- Coolant heater
- Extreme cold weather kit
- HMI211RS in-home display, including pre-configured 12" harness
- HMI211 remote display, including pre-configured 12" harness
- HMI220 remote display
- Auxiliary output relays (2)
- Auxiliary configurable signal inputs (8) and relay outputs (8)
- Annunciator – RS485
- Internet monitoring device – PowerCommand 500
- Battery chargers – stand-alone, 12V
- Enclosure Sound Level 1 to Sound Level 2 upgrade kit
- Enclosure paint touch up kit
- Base barrier – elevated generator set
- Alternator heater
- Maintenance and service kit
- Engine lift kit



⚠ WARNING:

Standby rating based on: Applicable for supplying emergency power for the duration of normal power interruption. No sustained overload capability is available for this rating. (Equivalent to fuel stop power in accordance with ISO3046, AS2789, DIN6271 and BS5514.) nominally rated. See T030.

⚠ WARNING:

Back feed to a utility system can cause electrocution and/or property damage. Do not connect to any building electrical except through an approved device or after building main breaker is open.

Transfer switch (also sold separately)

- Automatic Transfer Switches available in 100A and 200A.
- Service Entrance models also available, which helps reduce the installation cost.
- All models UL listed to UL 1008 standard.
- Available for both Indoor and Outdoor applications.
- Compact design and compatibility with the Cummins generator set helps reduce the installation time for the complete application.

Warranty policy

The Cummins RS and RX generator set models come with a 2 year standby warranty. Automatic Transfer Switches come standard with a 2 year warranty. Extended warranty options available. Please see Cummins' dealers/distributors for details.

After sale support

Largest distributor/dealer support network

Cummins Power Generation generator sets are supported by the largest and best trained worldwide certified distributor/dealer network in the industry. The network of knowledgeable and highly trained dealers will help you select the right generator for your application and advise you on associated accessories for your generator. The dealer network can also help answer any questions you may have regarding operation and maintenance requirements of the generators. This same network offers a complete selection of commonly used generator set maintenance parts, manuals and specification sheets.

Manuals: Operation and installation manuals ship with the generator set. To obtain additional copies or other manuals for this model, see your distributor/dealer and request the following manual numbers: Operator (A045R242), Installation (A045R241), Parts (A046Z674), Service (A045R243).

To easily locate the nearest certified distributor/dealer for Cummins generators in your area, or for more information, contact us at 1-800-344-0039 or visit power.cummins.com.

Contact your distributor/dealer for more information.

North America
1400 73rd Avenue N.E.
Minneapolis, MN 55432
USA

Phone 763 574 5000
Fax 763 574 5298

Our energy working for you.™

©2014 Cummins Inc. All rights reserved.

Cummins is a registered trademark of Cummins Inc.

"Our energy working for you." is a trademark of Cummins Power Generation. Other company, product, or service names may be trademarks or service marks of others. Specifications are subject to change without notice.

NAS-5775b-EN (1/14)



power.cummins.com