

Southwest Microwave, Inc.

Security Systems Division

TECHNICAL MANUAL

FOR

MODEL 310B-33456

EXPLOSIONPROOF OUTDOOR MICROWAVE LINK



TABLE OF CONTENTS

Introduction	3
Description	3
Optional Equipment	7
Specifications	8
Installation Instructions	10
Alignment and Testing	17
Seal Fitting	18
High Security Test Function	19
Preventative Maintenance	20
Warranty and Equipment Return Information.....	20

INTRODUCTION

Model 310B-33456 Explosion-proof Microwave Intrusion Link utilizes state-of-the-art technology to provide superior detection capability. The Transmitter is powered by a Gunn Diode oscillator which requires only 150mA (at 12VDC), permitting several links to be powered from a common power supply located at the control panel or other convenient location.

Model 310B-33456 solid state electronics and antenna are mounted in an explosion-proof housing which meets the ratings for hazardous areas. Heavy duty steel pole mounting brackets with horizontal and vertical adjustment are provided. Optional adjustable mounting hinges (part number 01B46384-A01) are available, providing +/- 20° adjustment.

DESCRIPTION

Each model 310B-33456 consists of one Model 310B-33456T Transmitter and one Model 310B-33456R Receiver, each with Unistrut mounting bracket. The transmitter radiates amplitude modulated K-band energy that travels to the receiver where it is detected. The received energy is amplified and processed so that it causes an alarm relay to be energized. When an intruder approaches the beam, received energy is changed causing the relay to be de-energized, and an alarm occurs. Operation of Model 310B-33456 is illustrated in Figure 1.

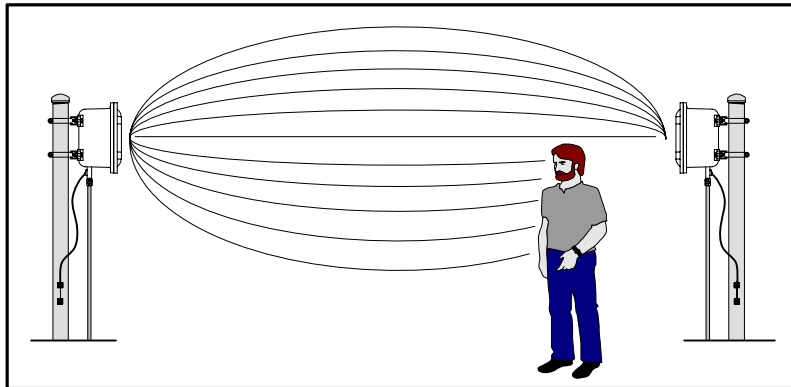

Figure 1 – Operation of T/R Link

A single Model 310B-33456 may cover a distance up to 328 feet (100m). The Receiver is equipped with automatic gain control (AGC), which automatically adjusts receiver for the distance to be covered.

Typical maximum width protection pattern of Model 310B-33456 is shown in Figure 2 for mounting height of 2.5 feet (.76m) above smooth earth.

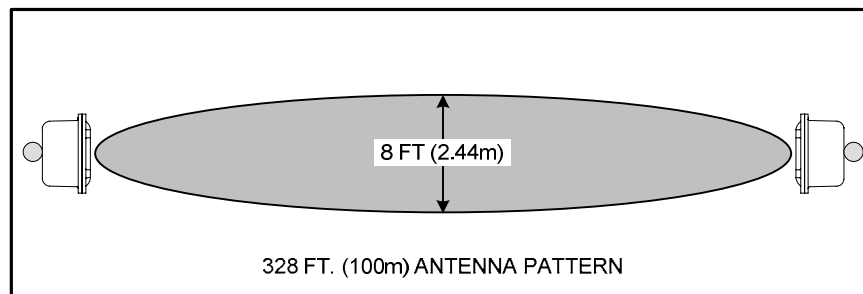

Figure 2 – Typical Maximum Horizontal Pattern

Maximum width is achieved when the Transmitter-Receiver distance is at maximum and Receiver “Sensitivity” control is set to maximum.

Figure 3 illustrates how pattern width varies with Transmitter-Receiver distance and sensitivity setting. Actual patterns will vary somewhat with site topography and surface condition. Generally, lower mounting height or rougher surface will increase pattern width.

For example, if the total link distance is 250 feet (76.2m) and the sensitivity adjustment set to mid-point. Figure 3 indicates the detection pattern width to be 4 feet (1.2m).

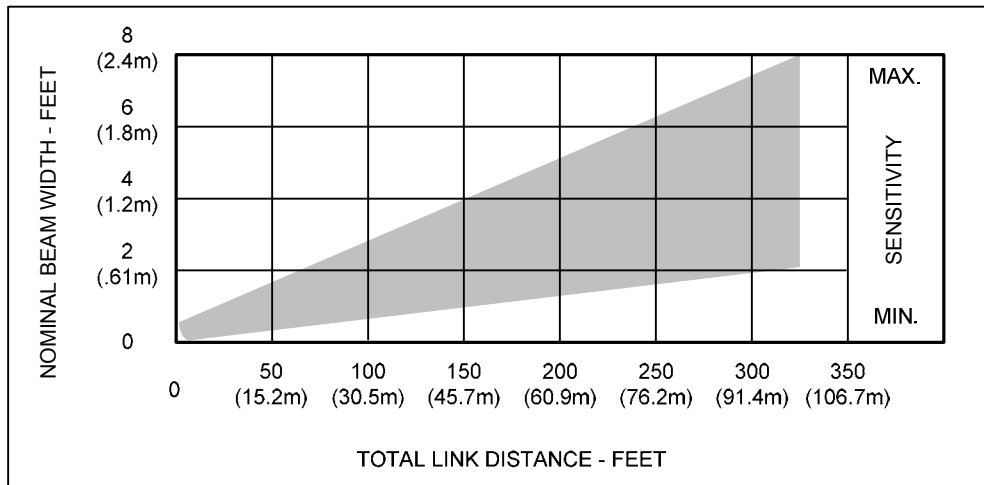

Figure 3 – Pattern Width vs Link Distance and Sensitivity

Vertical protection pattern will also depend upon Transmitter-Receiver distance, mounting height and “Sensitivity” setting. Protection pattern above Transmitter-Receiver centerline will be approximately half of the horizontal pattern as shown in Figure 4.

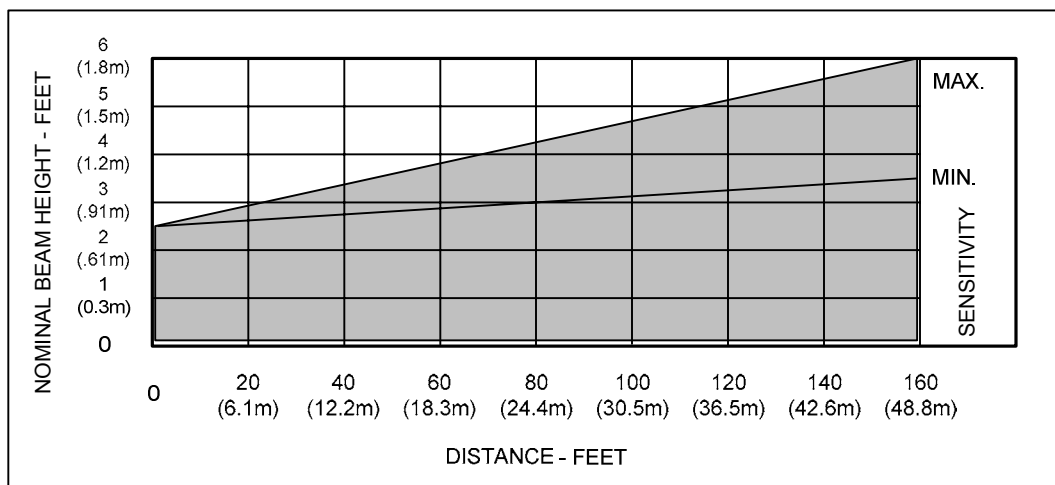

Figure 4 – Pattern Height vs Link Sensitivity

Protection pattern below centerline will tend to fill area between beam centerline and ground except for a “dead zone” immediately in front of and below Transmitter and Receiver. This dead zone is best protected by overlapping links at ends and corners as shown in Figures 5.

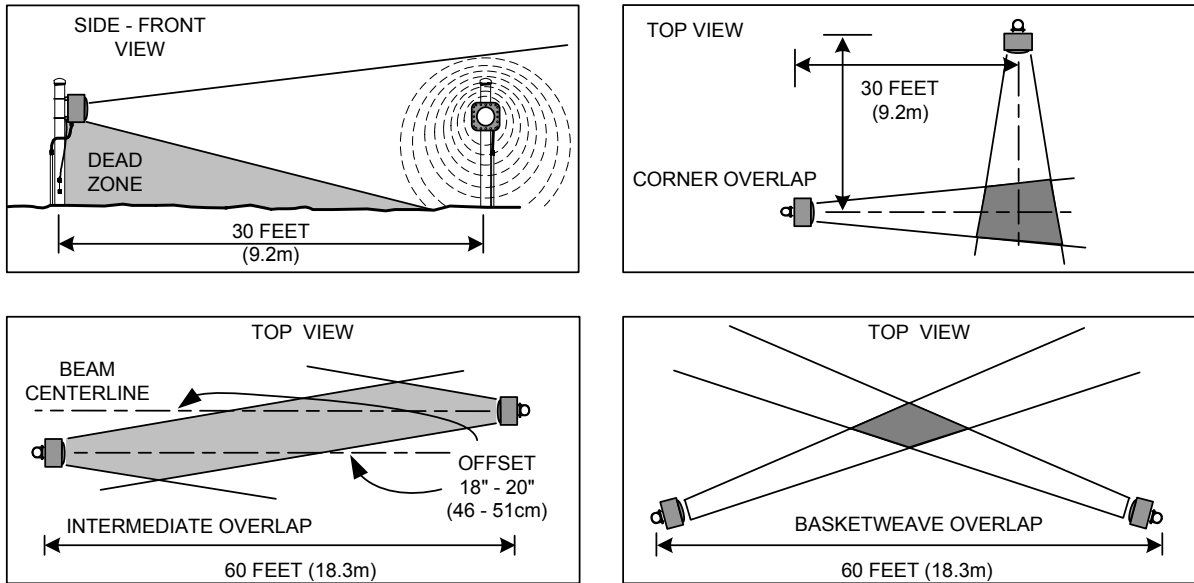

Figure 5 – Overlaps

Figure 6 shows amount of overlap required for protection against a hands and knees crawl, as a function of “Sensitivity” setting. For maximum security applications where detection of prone “commando style” crawl is required, the intermediate over-lap should be 60 feet (18.3m) minimum with parallel beam centerline offset of 18 inches (46cm) maximum. The corner overlaps should be 30 feet (9.2m) minimum. Terrain flatness should be no more than plus three inches or minus three inches deviation from a plane drawn between the transmitter and receiver. The zone length (Transmitter to Receiver) should not exceed 200 feet (61m).

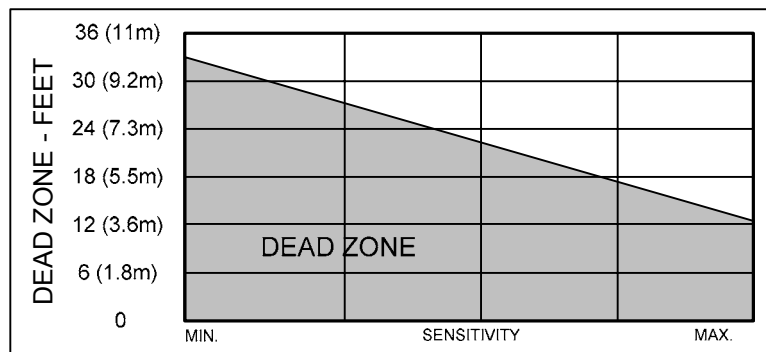

Figure 6 – “Sensitivity” vs Dead Zone

TRANSMITTER

Model 310B-33456 Transmitter consists of two major subassemblies – RF Assembly and Transmitter Circuit Board. A block diagram is shown in Figure 7.

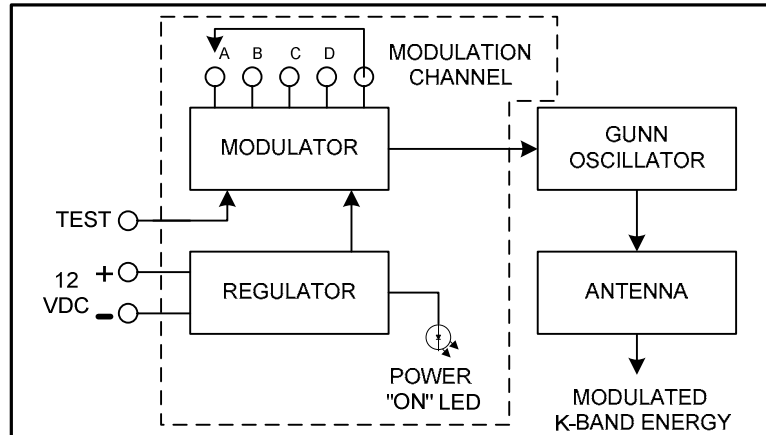

Figure 7 – Model 310B-33456T Transmitter

The RF assembly consists of a Gunn oscillator, which generates K-band microwave energy and the parabolic antenna system. The Transmitter circuit board contains voltage regulator and modulator circuit to drive the microwave oscillator. Modulation frequency is selected from one of four channels (A, B, C, D) on the Transmitter Circuit Board.

A “Test” terminal is provided on the Transmitter Circuit Board. Application of 5.0 to 14.0 VDC (from Power Supply) will cause Transmitter to turn off, generating a test alarm at receiver. A red “ON” LED on Transmitter Circuit Board indicates that power is on.

RECEIVER

Model 310B-33456R Receiver consists of three major subassemblies – RF Assembly, Receiver Circuit Board and Power Supply Board. A block diagram of Model 310B-33456R Receiver is shown in Figure 8. The RF Assembly consists of a parabolic antenna (identical to antenna of Transmitter) and a Schottky diode detector. The detector converts modulated K-band energy from Transmitter into an audio frequency signal for processing by Demodulator Circuit Board.

The received audio signal is amplified by an automatic gain control (AGC) preamplifier enabling the preamplifier output to be held to a constant level regardless of Transmitter Receiver distance (distance must be within maximum distance of Figure 2). Preamplifier output is applied to a phase locked loop (PLL) detector that operates as a narrow band-pass filter at one of the modulation frequencies. Receiver channel is selected by means of PCB jumper to match modulation frequency of Transmitter while rejecting spurious signals and other Transmitters.

PLL detector output is a voltage level that is held constant under normal conditions by the slow-acting AGC loop. Rapidly changing signal strength caused by a target moving into the microwave beam is not affected by AGC loop and causes an AC signal to appear at PLL detector output. Signal is amplified, filtered and compared with upper and lower alarm threshold voltages.

Whenever signal exceeds either threshold voltage, an alarm is generated. Gain of signal amplifier may be adjusted with “Sensitivity” potentiometer on circuit board to modify protection patterns per Figures 3. Signal bandwidth, affecting Model 310B-33456’s response to fast moving targets, may be set “Fast” or “Slow” with PCB Jumper.

The alarm relay circuit is factory adjusted to automatically reset after approximately two seconds, but hold-in time may be adjusted between 0.5 and 60 seconds by potentiometer on Power Supply Board. Moving PCB jumper from “Normal” to “Latch” may defeat automatic reset. In this condition an alarm will cause relay to latch in the alarm position until reset with 5-15 volt pulse on reset terminal.

Model 310B-33456R Receiver is equipped with various alignment and troubleshooting features. Alignment voltage test point provides a DC voltage proportional to received signal strength that may be measured with an ordinary VOM.

A red “Alarm” LED lights whenever an intrusion occurs. A red “Wrong Channel” LED lights whenever Transmitter and Receiver are set to different modulation channels. A red “Jamming” LED lights whenever Receiver is illuminated with a second Transmitter set to the same modulation channel. “Jamming” indication causes an alarm to be initiated.

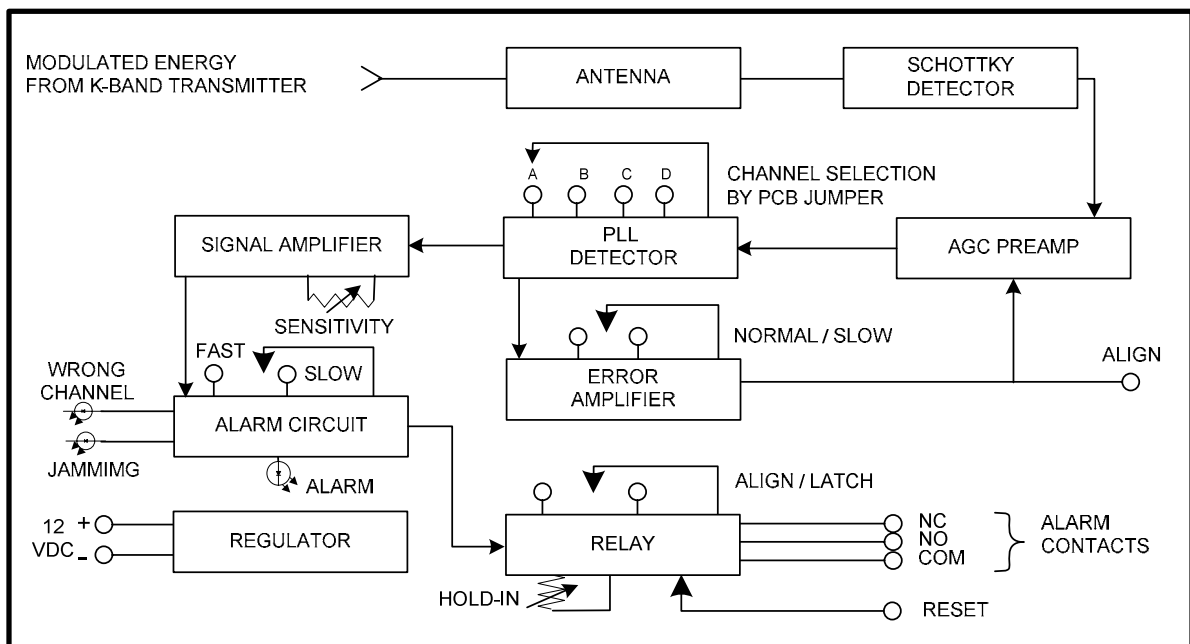

Figure 8 – Model 310B-33456R Receiver

OPTIONAL EQUIPMENT

Model PS40 Power Supply operates from 110 VAC, 50-60Hz, 0.5A and furnishes 13.7 VDC at up to 1.6A. Model PS41 Power Supply operates from 220 VAC, 50-60Hz, 0.25A. Power supplies contain automatic switchover and battery charging circuitry for optional standby batteries of up to 25AH. Power supplies are fused on both input and output for maximum protection.

Model PS50/51 Power Supply operates from a 16.5VAC, 50-60Hz, plug-in transformer such as Model PT61 or PT62 and furnishes 13.7VDC at up to 0.3A. It is designed for indoor operation, and is conveniently mounted inside a control panel. If mounted outdoors, it must be in a weatherproof enclosure. Model PS50 will charge a standby battery of up to 7.2AH.

Model PS13 Power Supply operates from 85-246VAC, 47-630Hz and furnishes 13.6 VDC at up to 2.8A. Power supplies contain automatic switchover and battery charging circuitry for optional standby batteries of up to 25AH. Temperature rated from 14° to 122° F (-10° to 50° C). UL, ETS, EMC, CE, RoHs compliant.

01B46384-A01: Tilt Mounting Assembly provides up/down (+/- 20°) adjustment to align transmitter and receiver. One required per transmitter and receiver.

Rechargeable standby batteries are available in several sizes.

Model BA30 – 12.6V 6.5AH jelly acid battery

Model RM83 Performance Test Set provides indication of (1) input power supply voltage, (2) alignment, (3) sensitivity and (4) audio/visual alarm indication. It is recommended for setup and maintenance testing.

SPECIFICATIONS

1.0 Detection Capability

- 1.1 Range: 100 feet (30.5m) to 328 feet (100m).
- 1.2 Beam Diameter: 2 feet (.6m) to 8 feet (2.4m) depending upon link distance and “Sensitivity” setting per Figure 3.
- 1.3 Target: 77 pound (35kg) human – walking, running, hands and knees crawling or jumping. Prone crawling or rolling 77 pound (35kg) human or simulated with a 12-inch (30cm) diameter metal sphere, detected at maximum range of 600 feet (183m).
- 1.4 Minimum Target Velocity: 0.1ft. /sec. (30mm/sec.)
- 1.5 Maximum Target Velocity: 10ft. /sec. (3m/sec.) slow setting, 50 ft. /sec. (15m. /sec.) fast setting.

2.0 Reliability

- 2.1 Equipment False Alarm Rate: 1/year/unit based upon signal-to-noise ratio at maximum sensitivity setting.
- 2.2 Probability of Detection: 0.99% minimum on 77 pound (35kg) human upright or on hands and knees.
- 2.3 Self Supervision (Alarm on Failure): Inherent in design (fully self-supervised).
- 2.4 Automatic Gain Control: Receiver sensitivity automatically adjusts to slow changes in environment. AGC range 54dB.
- 2.5 Cross Modulation: When installed in accordance with following installation instructions cross modulation (interference) from adjacent links will be 25dB below primary signal.

3.0 Transmittal Signal

- 3.1 Radiated Power: 10 milliwatts peak, 5 milliwatts average, square wave modulated.
- 3.2 Carrier Frequency: K-band (USA 24.125 GHz).
- 3.3 Modulation Frequencies: Four field-selectable modulation frequencies.
- 3.4 Above specifications for USA are in accordance with F.C.C. regulations.

4.0 Power Requirement

- 4.1 Voltage: 11.0 to 14.0VDC
- 4.2 Current: 150mA Transmitter, 20mA Receiver under normal ambient operating conditions.
- 4.3 Transmitter fused for 0.5 amp and Receiver each fused for 0.25 amps.

5.0 Alarm Indication

- 5.1 Alarm Relay Contacts: Primary alarm indications provided by two normally open contacts, two normally closed contacts and two common terminals (Form C), contact rating 2 amps at 28VDC.
- 5.2 Walk Test LED: Secondary alarm indication provided by red LED on Receiver Power Supply Board.
- 5.3 Jamming LED: Illumination of Receiver by second Transmitter operating on same channel lights red jamming LED and may initiate alarm condition.
- 5.4 Tamper Switch, Transmitter and Receiver: Form C contacts rated 2.0 Amp at 28 VDC.

6.0 Alignment and Test Aids

- 6.1 Alignment Voltage: Available at Receiver Test Point. Positive voltage, suitable for 100,000 ohms/volt VOM, increases with receiver signal strength. Range 0.5-5.0 VDC.
- 6.2 Align Mode: PCB jumper on Receiver Power Supply Board. "Alignment Mode" provides faster AGC action for alignment and constant alarm condition to prevent leaving link in Alignment Mode.
- 6.3 Wrong Channel – LED: Red LED on Receiver Power Supply Board lights when Transmitter and Receiver set to different channels.
- 6.4 Transmitter "ON" LED: Red LED on Transmitter Circuit Board indicates that power is on.
- 6.5 RM83 Performance Test Set can be used to aid in aligning and testing. RM83 is connected to side of 310B-33456R Receiver by a six (6) pin MS connector. Pin voltages are:

PIN	VOLTAGES	FUNCTIONS
A	11.0-14VDC	Input Power
B	8.0VDC \pm 0.5V	Internal Regulated Power
C	0.5VDC Minimum	Alignment (TPI)
D	0	Chassis Ground
E	3-4VDC (Typical)	Signal Voltage (Intrusion)
F	0.1VDC (Normal) 10-12VDC (Alarm)	Alarm Status

- 7.0 Weight, Transmitter, or Receiver: 48 pounds (21.8kg).

8.0 Operating Environment

- 8.1 Temperature: -40° F to +150° F (-40° C to +66° C)
- 8.2 Relative Humidity: 0 to 100%.

9.0 Dimensions (Transmitter or Receiver)

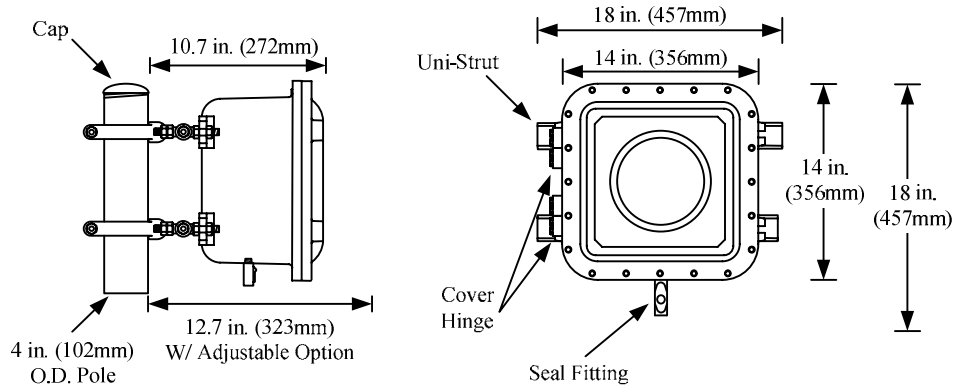

Figure 9 – Model 310B-33456 Transmitter or Receiver

10.0 Explosionproof Ratings

- NEC: Class 1 (Div. 1 & 2, Groups B, C, D), Class II (Div. 1 & 2, Groups E, F, G), Class III
- CSA Standard C22.2 No. 30
- EN 50 018 (XCEX)
- CENELEC: EExd IIB (XCEX)
- NEMA 4 and UL Standard 1203

INSTALLATION INSTRUCTIONS

A. Location of Model 310B-33456

Required Area: Model 310B-33456 must be located in an area which is free of obstructions and moving objects such as chain link fences, trees, bushes, poles and large areas of water. See Figure 10. Large moving objects within the protection pattern will be indistinguishable from an intruder and will cause nuisance alarms.

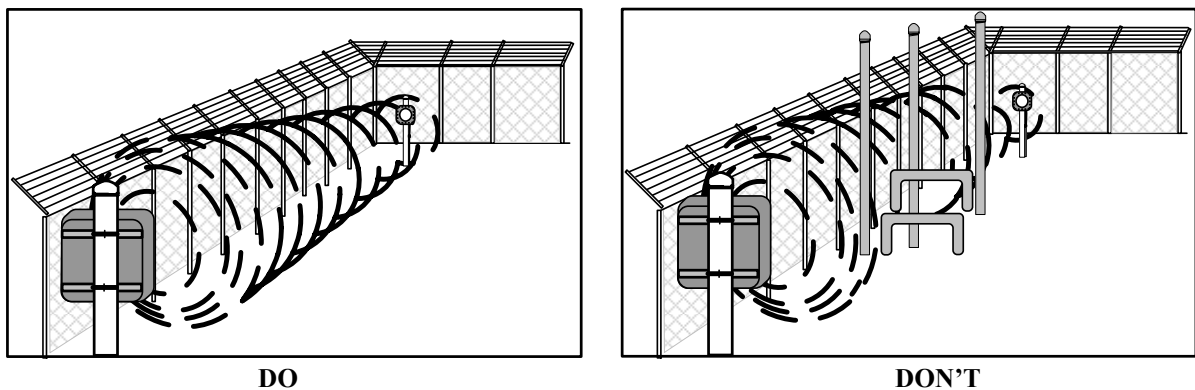

Figure 10 – Clear Area

The clear area required for a Model 310B-33456 installation depends upon the distance to be covered by the link. Protection patterns for various conditions are given in Figures 3. In each installation the clear area must be at least as large as the maximum protection pattern shown in Figure 3.

Terrain: Since the operation of Link requires transmission of energy from Transmitter to Receiver, it is important to maintain a clear line of sight between the units. Therefore, the ground must be flat across the protected area. Any bumps, hills or ditches in the area will shadow the beam and may provide crawl space for an intruder. Bumps or hills must be leveled, and ditches filled so that the area is flat to within six (6) inches (15cm). See Figure 11.

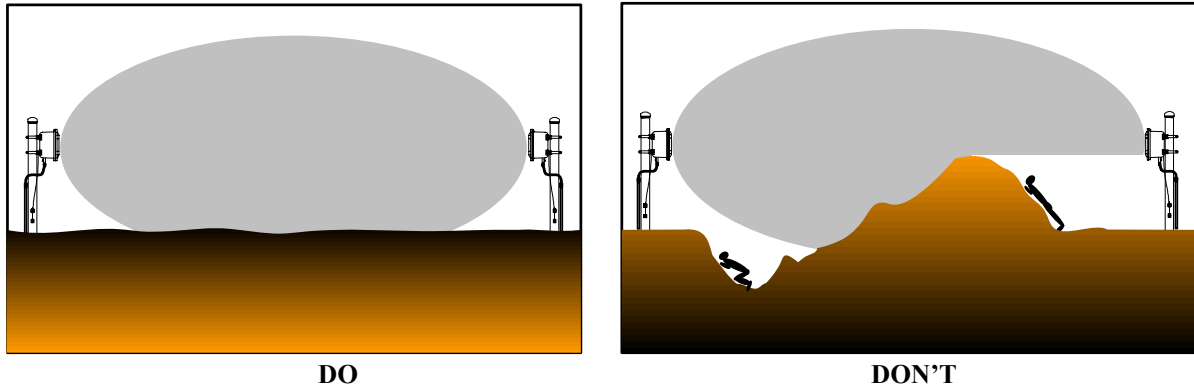

Figure 11 – Level Terrain

The protected area can be any stable, reasonably smooth material such as concrete, asphalt, tilled earth or gravel. If there is grass or vegetation in the protected area it must be kept cut to a maximum of three (3) inches (8cm) in height. Snow accumulation should not exceed three (3) inches (8cm) in height. A Model 310B-33456 Link should not be operated over open water.

Physical Protection: Install the Transmitter and Receiver in locations that provide protection from accidental damage as well as from tampering. Simple devices such as bumper posts or parking guards may be used to protect equipment from damage from vehicles. See Figure 12.

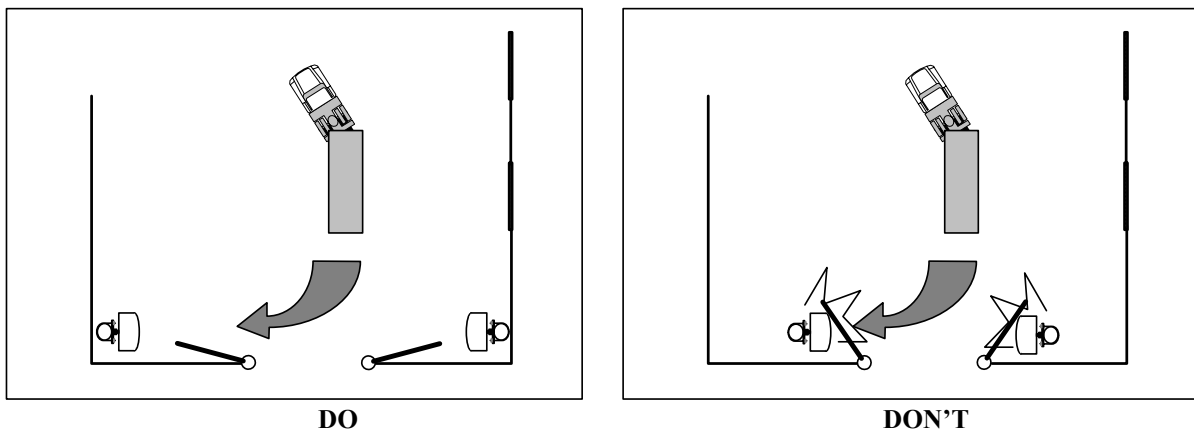

Figure 12 – Physical Protection

Best Security: Choose the location that will provide best security, yet be free from nuisance alarms. Always locate Model 310B-33456 inside a controlled access area to prevent unwanted alarms due to random foot traffic, vehicles, or large animals. Typically, units should be mounted two and one-half to three feet (0.75-1.0m) above ground level, and far enough inside fence to provide a clear area of protection. See Figures 13 & 14.

For maximum security it is necessary to overlap the ends of links so that the dead spot below and immediately in front of the adjoining link is protected. This type of location gives maximum possible security. A 60-foot (18m) overlap is recommended at intermediate points, and a 30-foot (9.2m) overlap is recommended at corners. If site demands shorter overlap, increased sensitivity will reduce dead zone, per

Figure 6, but will also widen beam, per Figure 3. The offset of overlapping links in line should be approximately 18 inches (46cm); this distance should be measured from center of each unit (See Figure 5). Additional protection may be added at critical points by installing SOUTHWEST MICROWAVE, INC. Model 380 or 385 Monostatic Sensors, Model 415 Passive Infrared Sensors, Model MS16 or MS16 Dual Technology Sensors or stacked links.

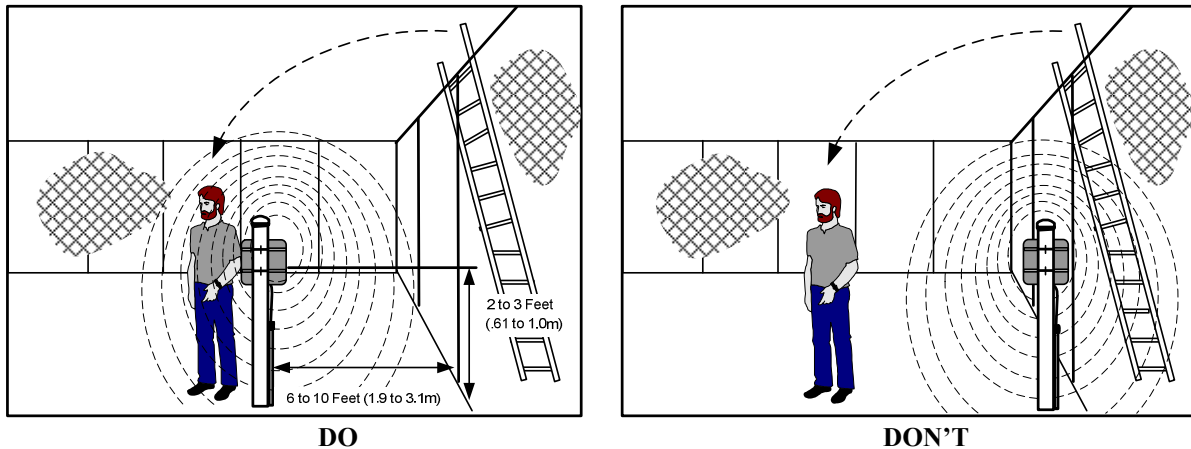

Figure 13 – Positioning off Fence

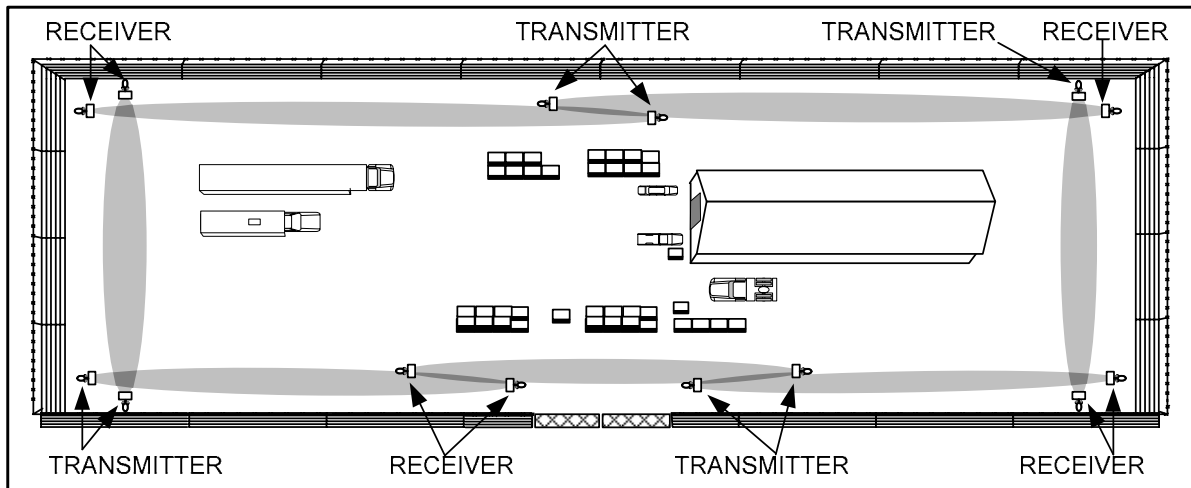

Figure 14 - Layout

Note from Figure 14 that at each point of overlap, either two Transmitters or two Receivers should be installed. This arrangement prevents an adjacent Transmitter and Receiver from establishing an unwanted link across the short overlap distance. If there is an odd number of links in an installation, a transmitter and receiver will need to be overlapped. This should be done in a corner as shown in Figure 14.

B. Power Supply Wiring

Model 310B-33456 requires only 150mA at 11.0-14VDC for each Transmitter and 20mA for each Receiver. Therefore, sufficient power with battery standby may already be available at the site from other sensor power supplies or from the control panel itself. Any regulated “12VDC” Supply will be adequate so long as noise and transients do not exceed 50mV and attention is paid to voltage drop in connecting wires so that voltage AT EACH TRANSMITTER OR RECEIVER remains between 11.0 and 14VDC. Voltage drop versus wire distances are given in Table 1.

WIRE GAUGE	VOLTAGE DROP PER 500 FT. (150m) TRANSMITTER	VOLTAGE DROP PER 500 FT. (150m) RECEIVER
# 16 AWG (1.29mm dia.)	.60V	.08V
# 18 AWG (1.05mm dia.)	.96V	.13V
# 20 AWG (0.82mm dia.)	1.5V	.20V
# 22 AWG (0.66mm dia.)	2.4V	.32V
# 24 AWG (0.54mm dia.)	3.8V	.51V

Table 1 – Voltage Drop vs Wire Gauges

C Mounting Model 310B-33456 T/R Link

1. Prepare a rigid mounting surface for the Model 310B-33456 Transmitter and Receiver. Do not mount units on a cyclone fence or any vibrating surface. A recommended mounting post is a 3 ½ inch (9cm) galvanized pipe (outside diameter 4 inches, 10cm), sunk into the ground in a concrete base, and protruding above ground level to a height of 4 feet (1.2m). Mount the Transmitter and Receiver 2 ½ to 3 feet (0.75 to 1.0m) above ground level and allow for height adjustment of at least plus or minus 6 inches (15cm). Height adjustment may be required during final alignment to achieve optimum protection pattern. See Figure 15. A “Seal Fitting” is required between sensor and rigid conduit. Flex conduit may be used in lieu of rigid. Check local standards for availability of use.

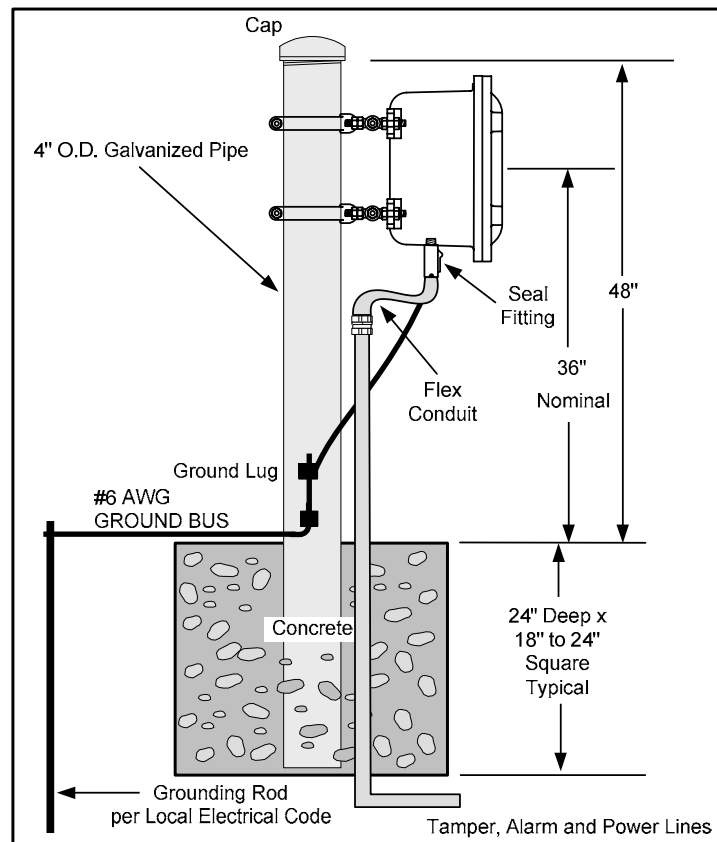

Figure 15 – Typical Mounting Detail

2. Remove the Model 310B-33456 T/R Link from the shipping containers. Attach the Unistrut brackets to the feet of the enclosure with the hardware provided.
3. Attached optional Tilt Mounting Assembly (if used) with provided hardware.
4. Secure the Unistrut brackets to the post with straps provided or to other mounting surface with appropriate screws or fasteners.

D. Connecting Model 310B-33456T Transmitter

Caution: DO NOT APPLY POWER UNTIL ALL WIRE CONNECTIONS HAVE BEEN MADE. VARIOUS WIRE TYPES CAN BE USED. CHECK LOCAL STANDARDS FOR WHICH WIRE TYPES MUST BE USED. SEE FOLLOWING INSTRUCTIONS.

1. Open the front hinged cover of Model 310B-33456T Transmitter by removing the twenty (20) bolts in the cover with a 9/16 wrench (#15 metric).
2. Insert power wires and optional tamper circuit wires through seal fitting. Leave enough slack in wires so that the cover can be opened.
3. Make connections to the terminal strip according to the labeled terminal functions as shown in Figure 16.
4. Attach power wires to “Input” terminal identified as +12VDC (Positive) and GND (Negative). OBSERVE POLARITY.

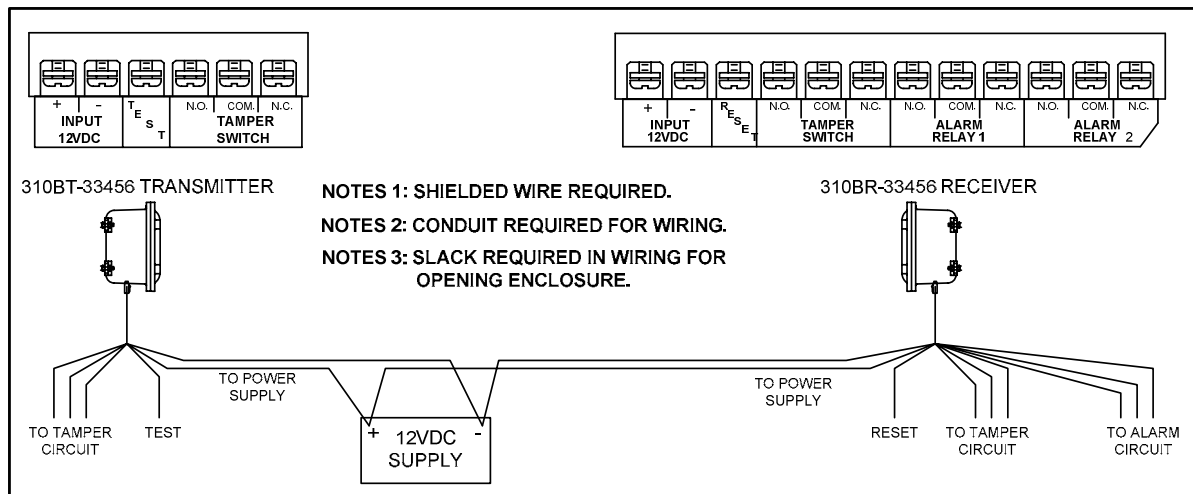

Figure 16 – Terminal Strips for Wiring

5. For protection against unauthorized openings or tampering, a tamper switch with a separate set of contacts is provided. Form C tamper contacts are available at “Tamper Switch” terminal.
6. Connect remote test wire if used, to terminal 3.

NOTE: After wiring is complete the seal fitting must be fitted with the fiber dam and sealing compound.

E. Connecting Model 310B-33456R Receiver

1. Open the front hinged cover of Model 310B-33456R Receiver by removing the twenty (20) bolts in the cover with a 9/16 wrench (#15 metric).
2. Insert power wires, alarm circuit wires and optional tamper circuit wires through conduit fitting. Leave enough slack in wires so that the cover can be opened.
3. Make connections to the terminal strip according to labeled terminal functions as shown in Figure 16.
4. Attach power wires to “Input” terminal identified as +12VDC (Positive) and GND (Negative). OBSERVE POLARITY.
5. Attach alarm circuit wires as follows:

CLOSED CIRCUIT ALARM: contacts (open on alarm) available at “Alarm Relay” COM and NC terminals.

OPEN CIRCUIT ALARM: contacts (close on alarm) available at “Alarm Relay” COM and NO terminals.

TAMPER contacts available at Tamper Switch terminals.

6. Connect reset wire if used, to terminal 3.

NOTE: After wiring is complete the seal fitting must be fitted with the fiber dam and sealing compound.

F. Modulation Frequency Selection

The Model 310B-33456T Transmitter features four (4) field selectable modulation frequencies. It is advantageous to use different modulation frequencies on links operating within close proximity. Different modulation frequencies reduce the possibility of cross-link modulation or mutual interference.

1. Select modulation channel different from the modulation of other links operating in the immediate area. The channels are listed as A, B, C and D.
2. Attach the white PCB jumper wire, E10, to one of the appropriate pins (A, B, C or D) to select the desired operating channel as shown in Figure 17.

The Model 310B-33456R Receiver also features four (4) field selectable frequencies. The Receiver and Transmitter **MUST** be operated on the same frequency for proper operation or an alarm condition will result.

3. Set the modulation frequency of the 310B-33456T Transmitter illuminating the 310B-33456R Receiver.
4. Attach the white PCB jumper wire, E9, to the appropriate pin (A, B, C, or D) at the Receiver that matches the same channel as the 310B-33456 Transmitter as shown in Figure 18.

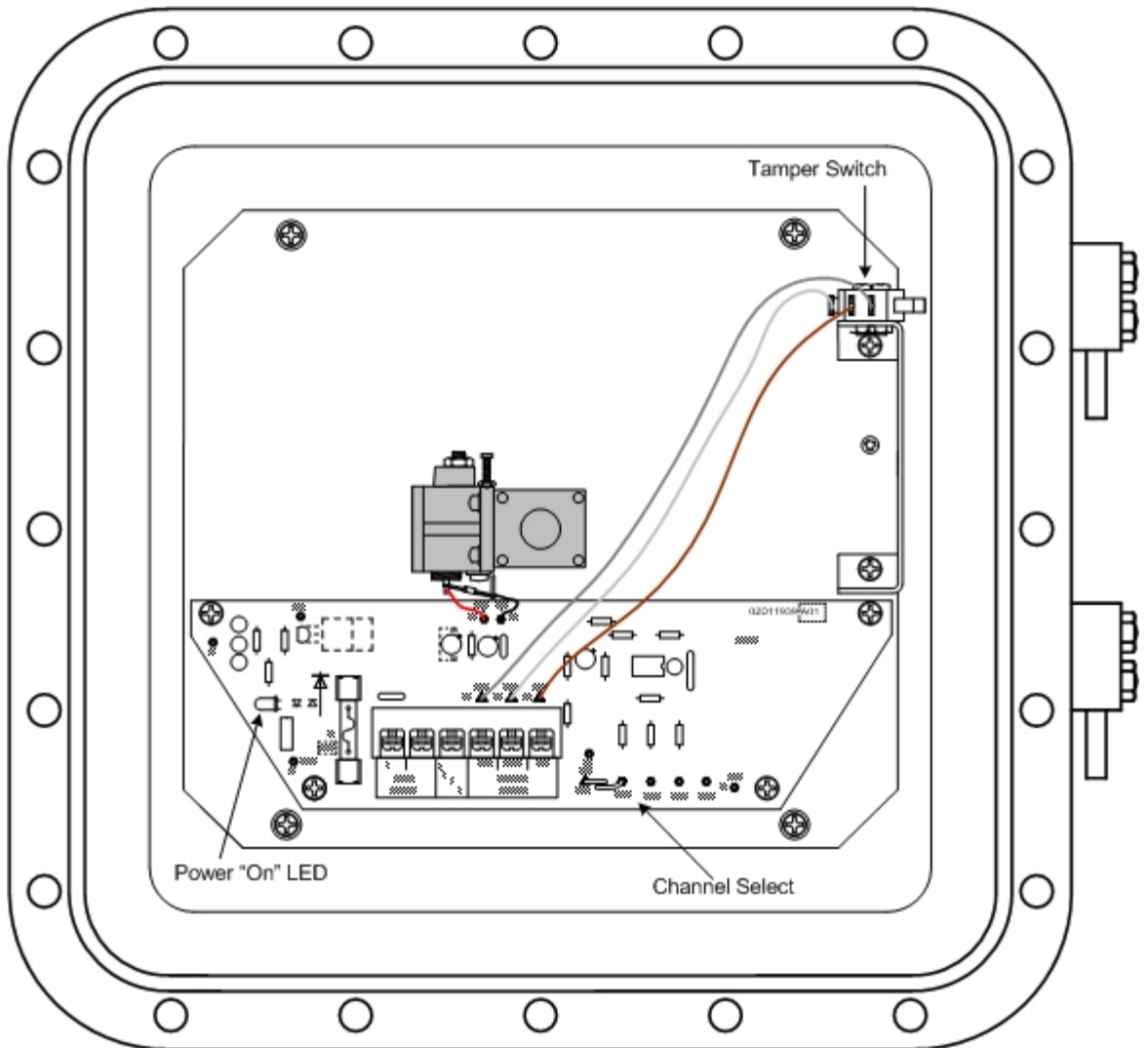

Figure 17 – Model 310B-33456T Transmitter

Figure 17 shows the location for the channel selection with jumper E10 to one of the channels (A, B, C, and D). It also shows where the power “On” LED and Tamper Switch are located.

Figure 18 shows the location for the channel selection with jumper E9 to one of the channels (A, B, C, and D). It also shows where the “Sensitivity” adjustment potentiometer, “Align/Latch” jumper E1, “Relay Hold” adjustment potentiometer, Tamper Switch, “Alarm” LED, “Wrong Channel” LED, “Jamming” LED and “RM83/Voltmeter” test plug are located.

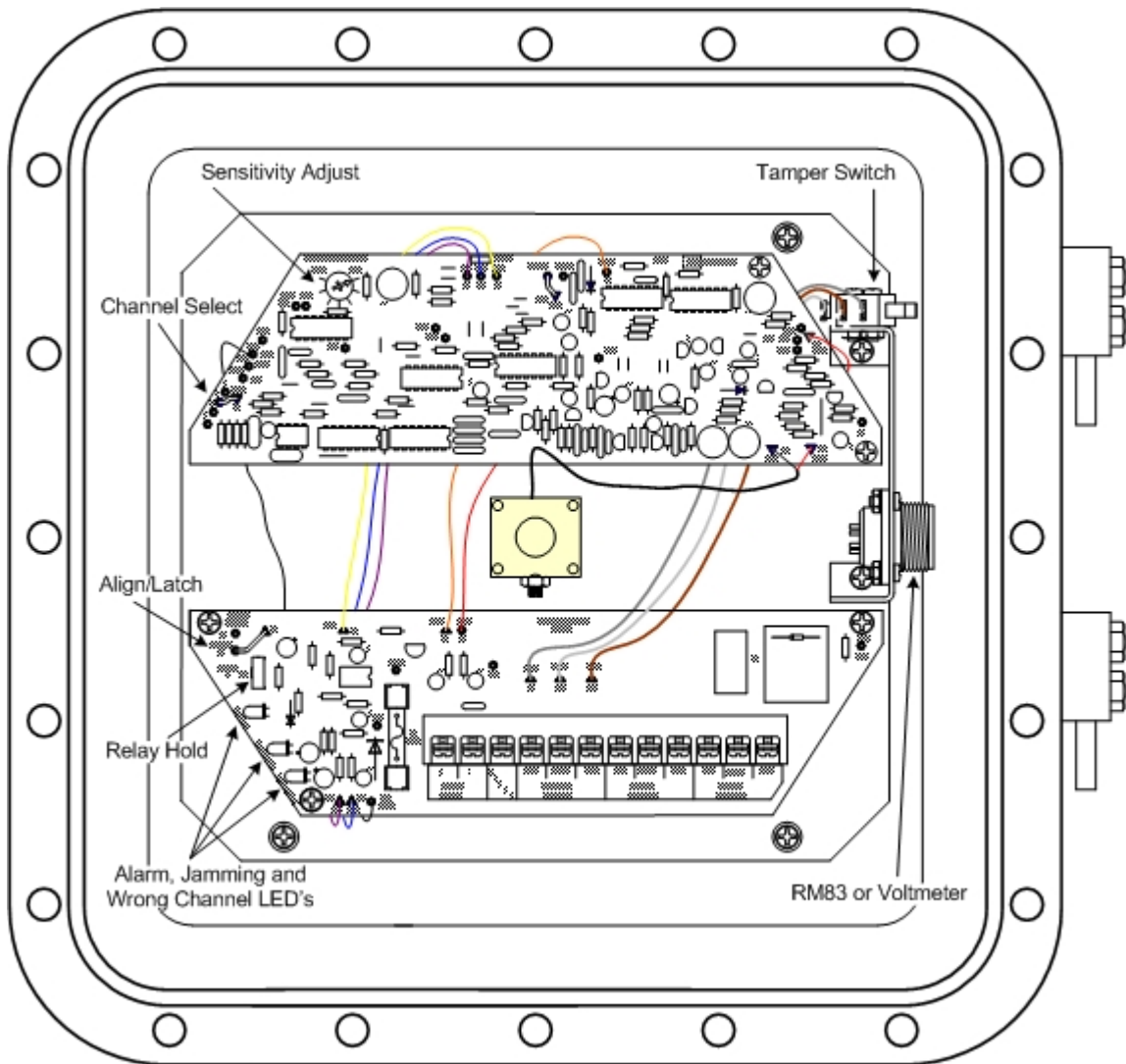

Figure 18 – Model 310B-33456R Receiver

ALIGNMENT AND TESTING

An MS type connector has been added to the side of the Receiver enclosure behind the seal plug. This connector, when used in conjunction with SOUTHWEST MICROWAVE Model RM83 Link Performance Test Set, will facilitate field alignment and testing of Model 310B-33456 Microwave Links with the cover of the enclosure closed. The following outline will assist the installer in alignment and testing of the Model 310B-33456 Microwave Intrusion Link using a VOM (volt-ohm-meter) with an input impedance of 100,000 ohms/volt or greater.

1. Apply power to the Transmitter and Receiver.
2. Be sure the identical modulation frequency is being used on the Transmitter and Receiver of the Link to be aligned.

3. Check for Transmitter operation by monitoring the Power “ON” LED on the Transmitter Circuit Board. (See Figure 17).
4. Close cover on Transmitter and secure with two (2) bolts.
5. Visually aim the Transmitter and Receiver for “bore-sight” alignment.
6. Open front cover of Receiver and move the Align/Latch – Normal jumper (E1) to Latch position. (See Figure 18). Close cover and secure with two (2) bolts.
7. On Receiver, connect VOM to Pin C (Positive Meter Lead), and Pin D GND (Negative Meter Lead), with meter range set to 3-5VDC. (See Figure 18).
8. Swivel Receiver side to side, to obtain maximum meter reading. Tighten mounting hardware to secure sensor in this position. (If optional Tilt Mounting Assembly is used, swivel Receiver up and down to obtain maximum meter reading).
9. Swivel Transmitter side to side, to obtain maximum meter reading. Tighten mounting hardware to secure sensor in this position. (If optional Tilt Mounting Assembly is used, swivel Transmitter up and down to obtain maximum meter reading).
10. Raise or lower mounting height of Receiver and/or Transmitter as required to obtain maximum meter reading. The minimum alignment and voltage for the Model 310B-33456 is 0.5VDC. Although this is the minimum voltage, proper alignment and mounting height will typically give a greater indication on the meter.
11. Disconnect VOM and move Align/Latch-Normal jumper to Normal position.
12. Walk test the Link to determine width of pattern, while monitoring alarm indication by means of red “Alarm” LED.
13. Adjust pattern width by turning “SENS” potentiometer clockwise to increase and counterclockwise to decrease, until desired width is obtained as shown in Figure 3.
14. Close cover on Transmitter and Receiver and secure using all twenty (20) bolts.

SEAL FITTING

After all connections have been made, the unit aligned and tested the “Seal Fitting” needs to be dammed, sealed and closed as shown in Figure 19. Insure that the access connections (wires) are long enough to permit the front cover of the enclosure to be opened after the sealing process is completed.

At the bottom of the seal fitting the fiber dam must be installed. Once installed the filling compound must be poured in either from the cap plug fitting or from the conduit opening in the enclosure. The cap plug(s) can be removed with an Allen head screwdriver. For ease of pouring the compound and funnel may be used. The compound should fill the reservoir to at least the bottom of the large cap plug.

Note: Insure wire lengths are long enough to permit opening of the enclosure cover after sealing.

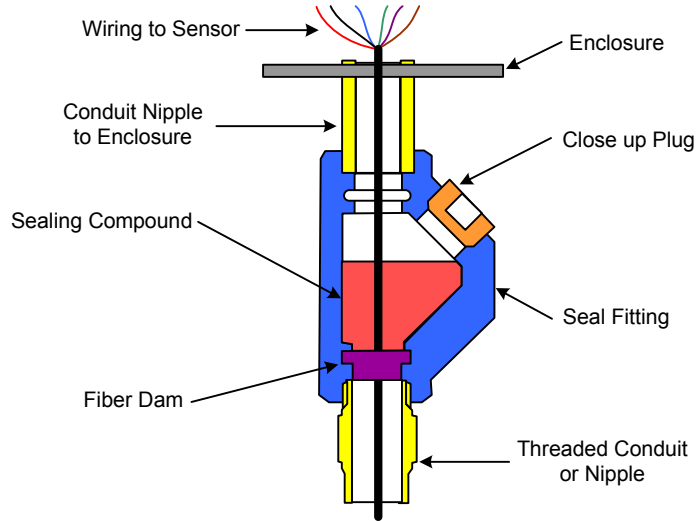

Figure 19 – Seal Fitting

HIGH SECURITY TEST FUNCTION

In high security areas, it is desirable to test and reset a link from a remote point. This feature has been incorporated into the Model 310B-33456.

1. To test the Transmitter, a voltage of 5 to 14VDC must be applied to terminal “TEST” on the Model 310B-33456T. (See Figures 16 and 17.)
2. Testing of the Transmitter may be accomplished by momentarily switching “ON” the 12VDC from the Power Supply to the “TEST” terminal. Note the “TEST” terminal requires +5 to 14VDC.
3. When the “TEST” is actuated, the Receiver will alarm. A higher degree of security can be obtained by utilizing the “Latch” function of the Model 310B-33456R Receiver.
4. Connect the “Align/Latch – Normal” PCB jumper to “Align/Latch” position. This will cause the Receiver to latch into the alarm state when either the “TEST” function is used at the Transmitter or an intrusion of the link has occurred.
5. To reset the link to the normal non-alarm condition, 5-15 VDC must be applied to terminal “Reset” on the Model 310B-33456R. (See Figures 15 and 18.)

By utilizing both the “Test” and “Reset” functions, the link can be tested and secured from a remote point.

PREVENTIVE MAINTENANCE

Model 310B-33456 requires no calibration other than alignment and sensitivity adjustment during installation. To maintain a trouble free system the following is recommended.

1. Clean the front cover glass every 3 to 6 months. (At maximum security installations, where detection of prone crawling targets is required, clean once a month.)
2. Keep the isolation area clean and free of tall grass, weeds, debris, and obstructions.
3. Upon initial installation, establish a zone data chart. Record input supply voltage, zone distance, transmitter/receiver mounting height, alignment voltage, modulation channel, sensitivity setting, and battery voltages.
4. If standby batteries are used, they should be functionally tested every three months.
5. A site inspection should be performed every six months. The inspection should include: verifying data from Step 3, checking for physical damage (cracks, leaks, corrosion, etc.) checking for isolation zone changes (washouts, materials placement, vegetation growth, loose fence fabric, etc.)
6. For troubleshooting information, please contact the factory about Model 310B Service Manual.

LIMITED WARRANTY

SOUTHWEST MICROWAVE, INC. warrants each of its products to be free from defects in materials and workmanship. The limit of liability under this warranty is to repair or replace any products or part thereof which shall within one year after delivery to the original user be returned, shipping costs prepaid and insured, to SOUTHWEST MICROWAVE, INC. at its plant in Tempe, Arizona, or authorized Warranty Service Company, and which shall have been found to be defective upon examination by SOUTHWEST MICROWAVE, INC. or authorized Warranty Service Company.

This warranty shall be limited to the repair or replacement of SOUTHWEST MICROWAVE, INC. products and shall not extend to any incidental or consequential damages there from. Disassembly of any product by anyone other than an authorized representative of SOUTHWEST MICROWAVE, INC. voids the obligations of SOUTHWEST MICROWAVE, INC. to repair or replace any products so disassembled.

Excluded from this warranty are fuses and batteries except to the extent that the original manufacturer warrants such parts, and such warranty is marked on the product. Claim under warranty for fuses and batteries should be made by the purchaser directly to the manufacturer.

Warranty returns must first be authorized by SOUTHWEST MICROWAVE, INC. or authorized Warranty Service Company.

SOUTHWEST MICROWAVE, INC. reserves the right to make changes in design on any of its products without incurring any obligation to make the same changes on units previously purchased.

This warranty is the extent of the obligations or liabilities assumed by SOUTHWEST MICROWAVE, INC. With respect to its products and is in lieu of all other warranties, express or implied, including, but not limited to, any warranty of merchantability or fitness. SOUTHWEST MICROWAVE, INC. shall not be liable for consequential damages and its liability is expressly limited to the obligations expressed herein. SOUTHWEST MICROWAVE, INC. Neither assumes nor authorizes any other person to assume for it any other warranty concerning its products.

RETURNING EQUIPMENT UNDER WARRANTY

As per the provisions set forth in our Security Products warranty, any person desiring to return equipment to SOUTHWEST MICROWAVE, INC. for any reason, must first contact SOUTHWEST MICROWAVE, INC. for authorization of return.

An authorization number will be issued at the time of authorization, and this number will appear on all correspondence, invoices and credits pertaining to subject equipment.

ALL SOUTHWEST MICROWAVE, INC. sensors and power supplies are provided with a serial number at the time of manufacture. In order to accurately and efficiently supply replacement parts, perform repair service, or issue credit on equipment being returned to SOUTHWEST MICROWAVE, INC., it is essential that SOUTHWEST MICROWAVE, INC. be advised of the serial number of the equipment prior to authorization for return. This notification may be made by telephone or by mail.

RETURNING EQUIPMENT FOR NON-WARRANTY REPAIR

Return of equipment out of warranty must first be authorized by SOUTHWEST MICROWAVE, INC. at which time a return authorization number will be issued. The returned equipment must be accompanied by an evaluation repair purchase order. Returned equipment will be examined and customer advised of cost of repair or replacement.

REPLACEMENT PARTS

To order a replacement or module, specify the complete part number and serial number and address the order or contact us at:

SOUTHWEST MICROWAVE, INC.

9055 South McKemy Street

Tempe, Arizona 85284-2946

TEL: (480) 783-0201

FAX: (480) 783-0401

Infosd@southwestmicrowave.com

www.southwestmicrowave.com