

GE Oil & Gas

# 19000 Series

Consolidated\* Safety Relief Valve  
Maintenance Manual



imagination at work



THESE INSTRUCTIONS PROVIDE THE CUSTOMER/OPERATOR WITH IMPORTANT PROJECT-SPECIFIC REFERENCE INFORMATION IN ADDITION TO THE CUSTOMER/OPERATOR'S NORMAL OPERATION AND MAINTENANCE PROCEDURES. SINCE OPERATION AND MAINTENANCE PHILOSOPHIES VARY, GE (GENERAL ELECTRIC COMPANY AND ITS SUBSIDIARIES AND AFFILIATES) DOES NOT ATTEMPT TO DICTATE SPECIFIC PROCEDURES, BUT TO PROVIDE BASIC LIMITATIONS AND REQUIREMENTS CREATED BY THE TYPE OF EQUIPMENT PROVIDED.

THESE INSTRUCTIONS ASSUME THAT OPERATORS ALREADY HAVE A GENERAL UNDERSTANDING OF THE REQUIREMENTS FOR SAFE OPERATION OF MECHANICAL AND ELECTRICAL EQUIPMENT IN POTENTIALLY HAZARDOUS ENVIRONMENTS. THEREFORE, THESE INSTRUCTIONS SHOULD BE INTERPRETED AND APPLIED IN CONJUNCTION WITH THE SAFETY RULES AND REGULATIONS APPLICABLE AT THE SITE AND THE PARTICULAR REQUIREMENTS FOR OPERATION OF OTHER EQUIPMENT AT THE SITE.

THESE INSTRUCTIONS DO NOT PURPORT TO COVER ALL DETAILS OR VARIATIONS IN EQUIPMENT NOR TO PROVIDE FOR EVERY POSSIBLE CONTINGENCY TO BE MET IN CONNECTION WITH INSTALLATION, OPERATION OR MAINTENANCE. SHOULD FURTHER INFORMATION BE DESIRED OR SHOULD PARTICULAR PROBLEMS ARISE WHICH ARE NOT COVERED SUFFICIENTLY FOR THE CUSTOMER/OPERATOR'S PURPOSES THE MATTER SHOULD BE REFERRED TO GE.

THE RIGHTS, OBLIGATIONS AND LIABILITIES OF GE AND THE CUSTOMER/OPERATOR ARE STRICTLY LIMITED TO THOSE EXPRESSLY PROVIDED IN THE CONTRACT RELATING TO THE SUPPLY OF THE EQUIPMENT. NO ADDITIONAL REPRESENTATIONS OR WARRANTIES BY GE REGARDING THE EQUIPMENT OR ITS USE ARE GIVEN OR IMPLIED BY THE ISSUE OF THESE INSTRUCTIONS.

THESE INSTRUCTIONS CONTAIN PROPRIETARY INFORMATION OF GE, AND ARE FURNISHED TO THE CUSTOMER/OPERATOR SOLELY TO ASSIST IN THE INSTALLATION, TESTING, OPERATION, AND/OR MAINTENANCE OF THE EQUIPMENT DESCRIBED. THIS DOCUMENT SHALL NOT BE REPRODUCED IN WHOLE OR IN PART NOR SHALL ITS CONTENTS BE DISCLOSED TO ANY THIRD PARTY WITHOUT THE WRITTEN APPROVAL OF GE.

# Conversion Table

**All the United States Customary System (USCS) values are converted to metric values using the following conversion factors:**

Metric values using the following conversion factors:	Conversion Factor	Metric Unit
in.	25.4	mm
lb.	0.4535924	kg
in <sup>2</sup>	6.4516	cm <sup>2</sup>
ft <sup>3</sup> /min	0.02831685	m <sup>3</sup> /min
gal/min	3.785412	L/min
lb/hr	0.4535924	kg/hr
psig	0.06894757	barg
ft lb	1.3558181	Nm
°F	5/9 (°F-32)	°C

Note 1: Multiply USCS value with conversion factor to get metric value.

## NOTICE

For valve configurations not listed in this manual, please contact your local Consolidated Green Tag\* Center for assistance.

# Table of Contents

Section	Subject	Page No
	Conversion Table.....	2
I.	Product Safety Sign and Label System .....	5
II.	Safety Alerts .....	6
III.	Safety Notice.....	7
IV.	Warranty Information.....	8
V.	Terminology for Safety Relief Valves.....	8
VI.	Handling, Storage, and Pre-Installation .....	9
VII.	Pre-Installation and Installation Instructions .....	10
<b>VIII.</b>	<b>Design Features and Nomenclature</b> .....	10
	A. General Information.....	10
	B. Design Options.....	10
	C. Nomenclature .....	10
<b>IX.</b>	<b>Introduction</b> .....	11
	A. 19000 MS & DA Safety Relief Valves .....	11
	B. 19096M-DA-BP Safety Relief Valves .....	11
<b>X.</b>	<b>Consolidated 19000 Series SRV</b> .....	12
	A. Metal Seat Valve.....	12
	B. Standard Cap Types .....	13
	C. Soft Seat Valve.....	14
	D. The 19096M-DA-BP Valve.....	15
<b>XI.</b>	<b>Recommended Installation Practices</b> .....	16
	A. Mounting Position .....	16
	B. Inlet Piping .....	16
	C. Outlet Piping .....	17
<b>XII.</b>	<b>Disassembly of 19000 Series SRV</b> .....	18
	A. General Information .....	18
	B. Disassembly.....	19
	C. Cleaning.....	19
<b>XIII.</b>	<b>Maintenance</b> .....	20
	A. Metal Seat Valves (MS).....	20
	B. O-Ring Seat Seal Valves (DA) .....	25
	C. Checking Spindle Concentricity .....	26
<b>XIV.</b>	<b>Inspection and Part Replacement</b> .....	27
	A. Base .....	27
	B. Metal Seat Disc .....	27
	C. O-Ring Seat Seal Assembly .....	27
	D. Bonnet.....	27
	E. O-Ring Disc Holder.....	27
	F. Guide .....	28
	G. Spindle .....	28

# Table of Contents

Section	Subject	Page No
	G.1 MS & DA .....	28
	G.2 DA - BP .....	28
	H. Spring .....	29
	I. Spring Washers .....	29
	J. Adjusting Screw .....	29
	K. Bonnet Top .....	29
	L. Bonnet Bottom .....	30
	M. Backup Plate .....	30
	N. Spindle O-Ring .....	30
	O. Backup Plate O-Ring .....	30
	P. Seat O-Ring .....	30
<b>XV.</b>	<b>Reassembly of 19000 Series SRV</b> .....	30
	A. Metal Seat Valves (MS) .....	30
	B. O-Ring Seat Seal Valves (DA) .....	31
	C. 19096M-DA-BP O-Ring Seat Seal Valves .....	31
<b>XVI.</b>	<b>Setting and Testing</b> .....	33
	A. General Information .....	33
	B. Test Equipment .....	33
	C. Test Media .....	33
	D. Setting the Valve .....	33
	E. Set Pressure Compensation .....	33
	F. Blowdown .....	34
	G. Simmer .....	35
	H. Seat Leakage .....	35
	I. Back Pressure Testing (MS & DA) .....	35
	J. Hydrostatic Testing and Gagging .....	37
	K. Manual Popping of the Valve .....	37
XVII.	Trouble Shooting Guide .....	37
XVIII.	Maintenance Tools and Supplies .....	38
<b>XIX.</b>	<b>Replacement Parts Planning</b> .....	39
	A. General Information .....	39
	B. Inventory Planning .....	39
	C. Replacement Parts List .....	39
	D. Identification and Ordering Essentials .....	39
<b>XX.</b>	<b>Genuine Consolidated Parts</b> .....	39
XXI.	Recommended Spare Parts .....	40
<b>XXI.</b>	<b>Field Service, Training, and Repair Program</b> .....	41
	A. Field Service .....	41
	B. Factory Repair Facilities .....	41
	C. SRV Maintenance Training .....	41
	Notes: .....	42

# I. Product Safety Sign and Label System

If and when required, appropriate safety labels have been included in the rectangular margin blocks throughout this manual. Safety labels are vertically oriented rectangles as shown in the *representative examples* (below), consisting of three panels encircled by a narrow border. The panels can contain four messages which communicate:

- The level of hazard seriousness
- The nature of the hazard
- The consequence of human, or product, interaction with the hazard.
- The instructions, if necessary, on how to avoid the hazard.

The top panel of the format contains a signal word (DANGER, WARNING, CAUTION or ATTENTION) which communicates the level of hazard seriousness.

The center panel contains a pictorial which communicates the nature of the hazard, and the possible consequence of human or product interaction with the hazard. In some instances of human hazards the pictorial may, instead, depict what preventive measures to take, such as wearing protective equipment.

The bottom panel may contain an instruction message on how to avoid the hazard. In the case of human hazard, this message may also contain a more precise definition of the hazard, and the consequences of human interaction with the hazard, than can be communicated solely by the pictorial.

① **DANGER** — Immediate hazards which **WILL** result in severe personal injury or death.

② **WARNING** — Hazards or unsafe practices which **COULD** result in severe personal injury or death.

③ **CAUTION** — Hazards or unsafe practices which **COULD** result in minor personal injury.

④ **ATTENTION** — Hazards or unsafe practices which **COULD** result in product or property damage



## II. Safety Alerts

### Read - Understand - Practice

#### Danger Alerts

A DANGER alert describes actions that may cause severe personal injury or death. In addition, it may provide preventive measures to avoid severe personal injury or death.

DANGER alerts are not all-inclusive. GE cannot know all conceivable service methods nor evaluate all potential hazards.

Dangers include:

- High temperature/pressure can cause injury. Ensure all system pressure is absent before repairing or removing valves.
- Do not stand in front of a valve outlet when discharging. STAND CLEAR OF VALVE to avoid exposure to trapped, corrosive media.
- Exercise extreme caution when inspecting a pressure relief valve for leakage.
- Allow the system to cool to room temperature before cleaning, servicing, or repairing. Hot components or fluids can cause severe personal injury or death.
- Always read and comply with safety labels on all containers. Do not remove or deface container labels. Improper handling or misuse could result in severe personal injury or death.
- Never use pressurized fluids/gas/air to clean clothing or body parts. Never use body parts to check for leaks, flow rates, or areas. Pressurized fluids/gas/air injected into or near the body can cause severe personal injury or death.
- It is the owner's responsibility to specify and provide protective wear to protect persons from pressurized or heated parts. Contact with pressurized or heated parts can result in severe personal injury or death.

- Do not work or allow anyone under the influence of intoxicants or narcotics to work on or around pressurized systems. Workers under the influence of intoxicants or narcotics are a hazard to themselves and other employees. Actions taken by an intoxicated employee can result in severe personal injury or death to themselves or others.
- Always perform correct service and repair. Incorrect service and repair can result in product or property damage or severe personal injury or death.
- Always use the correct tool for a job. The misuse of a tool or the use of an improper tool can result in personal injury, damage to product or property.
- Ensure the proper "health physics" procedures are followed, if applicable, before starting operation in a radioactive environment.

#### Caution Alerts

A CAUTION alert describes actions that may result in a personal injury. In addition, they may describe preventive measures that must be taken to avoid personal injury. Cautions include:

- Heed all service manual warnings. Read installation instructions before installing valve(s).
- Wear hearing protection when testing or operating valves.
- Wear appropriate eye and clothing protection.
- Wear protective breathing apparatus to protect against toxic media.



### III. Safety Notice



Proper installation and start-up is essential to the safe and reliable operation of all valve products. The relevant procedures recommended by GE, and described in these instructions, are effective methods of performing the required tasks.

It is important to note that these instructions contain various “safety messages” which should be carefully read in order to minimize the risk of personal injury, or the possibility that improper procedures will be followed which may damage the involved GE product, or render it unsafe. It is also important to understand that these “safety messages” are not exhaustive. GE cannot possibly know, evaluate, and advise any customer of all of the conceivable ways in which tasks might be performed, or of the possible hazardous consequences of each way. Consequently, GE has not undertaken any such broad evaluation and, thus, anyone who uses a procedure and/or tool, which is not recommended by GE, or deviates from GE recommendations, must be thoroughly satisfied that neither personal safety, nor valve safety, will be jeopardized by the method and/or tools selected. Contact GE at (318) 640-6055 if there are any questions relative to tools/ methods.

The installation and start-up of valves and/or valve products may involve proximity to fluids at extremely high pressure and/or temperature. Consequently, every precaution should be taken to prevent injury to personnel during the performance of any procedure. These precautions should consist of, but are not limited to, ear drum protection, eye protection, and the use of protective clothing, (i.e., gloves, etc.) when personnel are in, or around, a valve work area. Due to the various circumstances and conditions in which these operations may be performed on GE products, and the possible hazardous consequences of each way, GE cannot possibly evaluate all conditions that might injure personnel or equipment. Nevertheless, GE does offer certain Safety Alerts, listed in Section II, for customer information only.

It is the responsibility of the purchaser or user of Consolidated valves/ equipment to adequately train all personnel who will be working with the involved valves/equipment. For more information on training schedules, call 318/640-6054. Further, prior to working with the involved valves/equipment, personnel who are to perform such work should become thoroughly familiar with the contents of these instructions. Additional copies of these instructions can be purchased, at a minimal cost, by contacting GE (in writing) at P.O. Box 1430, Alexandria, LA 71309-1430, or by calling at 318/ 640-2250, Fax (318) 640-6325.

## IV. Warranty Information

Warranty Statement: General Electric warrants that its products and work will meet all applicable specifications and other specific product and work requirements (including those of performance), if any, and will be free from defects in material and workmanship.

CAUTION: Defective and nonconforming items must be held for GE's inspection and returned to the manufacturer upon request.

Incorrect Selection or Misapplication of Products: GE cannot be responsible for customers' incorrect selection or misapplication of our products.

Unauthorized Repair work: GE has not authorized any non-GE-affiliated repair companies, contractors or individuals to perform warranty repair service on new products or field repaired products of its manufacture. Therefore, customers contracting such repair services from unauthorized sources do so at their own risk.

Unauthorized Removal of Seals: All new valves and valves repaired in the field by GE Consolidated Field Service are sealed to assure the customer of our guarantee against defective workmanship. Unauthorized removal and/or breakage of this seal will negate our warranty.

Note 1 Refer to GE's Standard Terms of Sale for complete details on warranty and limitation of remedy and liability.

## V. Terminology for Safety Relief Valves (SRV)

- Accumulation - the pressure increase over the maximum allowable working pressure of the vessel during discharge through the SRV, expressed as a percentage of that pressure or in actual pressure units.
- Backpressure - the pressure on the discharge side of the SRV:
  - Built-up Backpressure - the pressure that develops at the valve outlet, after the SRV has been opened, as a result of flow.
  - Superimposed Backpressure - the pressure in the discharge header before the SRV is opened.
  - Constant Backpressure - the superimposed backpressure that is constant with time.
  - Variable Backpressure - the superimposed backpressure that varies with time.
- Blowdown - the difference between set pressure and re-seating pressure of the SRV, expressed as a percentage of the set pressure or in actual pressure units.
- Cold Differential Set Pressure - the pressure at which the valve is adjusted to open on the test stand. This pressure includes the corrections for backpressure and/or temperature service conditions.
- Differential Between Operating and Set Pressures Valves in installed process services will generally give best results if the operating pressure does not exceed 90 percent of the set pressure. However, on pump and compressor discharge lines, the differential required between the operating and set pressures may be greater because of pressure pulsations coming from a reciprocating piston. The valve should be set as far above the operating pressure as possible.

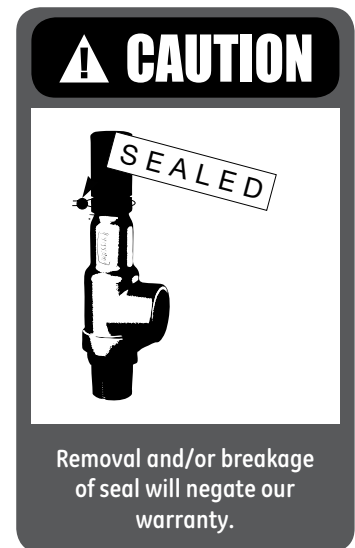

# V. Terminology for Safety Relief Valves (Contd.)

- Lift - the actual travel of the disc away from the closed position when a valve is relieving.
- Maximum Allowable Working Pressure - the maximum gauge pressure permissible in a vessel at a designated temperature. A vessel may not be operated above this pressure, or its equivalent, at any metal temperature other than that used in its design. Consequently, for that metal temperature, it is the highest pressure at which the primary pressure SRV is set to open.
- Operating Pressure - the gauge pressure to which the vessel is normally subjected in service. A suitable margin is provided between operating pressure and maximum allowable working pressure. For assured safe operation, the operating pressure should be at least 10 percent under the maximum allowable working pressure or 5 psi (.34 bar), whichever is greater.
- Overpressure - a pressure increase over the set pressure of the primary relieving device. Overpressure is similar to accumulation when the relieving device is set at the maximum allowable working pressure of the vessel. Normally, overpressure is expressed as a percentage of set pressure.
- Rated Capacity - the percentage of measured flow at an authorized percent overpressure permitted by the applicable code. Rated capacity is generally expressed in pounds per hour (lb/hr) for vapors, standard cubic feet per minute (SCFM) or m<sup>3</sup>/min for gases, and in gallons per minute (GPM) for liquids.
- Relief Valve - an automatic pressure-relieving device, actuated by static pressure upstream from the valve. A relief valve is used primarily for liquid service.
- Safety Relief Valve (SRV) - an automatic pressure-relieving device used as either a safety or relief valve, depending upon application. The SRV is used to protect personnel and equipment by preventing excessive overpressure.
- Safety Valve - an automatic pressure-relieving device actuated by the static pressure upstream of the valve, and characterized by a rapid opening or “pop” action. It is used for steam, gas, or vapor service.
- Set Pressure - the gauge pressure at the valve inlet for which the relief valve has been adjusted to open under service conditions. In liquid service, the inlet pressure at which the valve starts to discharge determines set pressure. In gas or vapor service, the inlet pressure at which the valve pops determines the set pressure.
- Simmer - the audible passage of a gas or vapor across the seating surfaces just before “pop.” The difference between this start-to-open pressure and the set pressure is called “simmer.” Simmer is generally expressed as a percentage of set pressure.

# VI. Handling, Storage

## Handling

Valves should not be shipped with the inlet flange down. These valves should be kept in their factory foam-filled carton until installation.

**ATTENTION!**

Never lift the valve by the lifting lever.

**ATTENTION!**

Handle carefully. Do not drop or strike the valve.

Do not subject SRVs, either crated or uncrated, to sharp impact. Ensure that the valve is not bumped or dropped during loading or unloading from a truck. While hoisting the valve, take care to prevent bumping the valve against steel structures and other objects.

**ATTENTION!**

Prevent dust and debris from entering inlet or outlet of the valve.

## Storage

Store SRVs in a dry environment and protect them from the weather. Do not remove the valve from the skids or crates until immediately before installation.

Do not remove flange protectors and seating plugs until the valve is ready to be bolted into place during the installation.

Screwed/portable valves should be kept in their factory foam-filled carton until installation to avoid damage to external inlet threads.

## VII. Pre-Installation and Installation Instructions

When SRVs are uncrated and the flange protectors or sealing plugs are removed, exercise meticulous care to prevent dirt and other foreign materials from entering the inlet and outlet ports while bolting the valve in place.

## VIII. Design Features and Nomenclature

### A. General Information

The Series 19000 Portable Safety Relief Valve has 316 stainless steel trim as standard material. Reliable performance and easy maintenance procedures are characteristics of this valve, when properly installed in suitable applications for its design.

The 19000 Series SRV has three pressure classes—19000L 5-290 psig (0.34-19.99 barg), 19000M 291-2000 psig (20.06-137.90 barg) and 19000H 2001 psig (137.96 barg) and up. Standard 19000 parts are used for both liquid applications and gas applications. It is designed for short blowdown on all types of media, typically less than 10 percent.

All 19000 Series safety relief valves have fixed blowdown. This means that the parts are designed so that there is no blowdown adjustment required when setting or testing the valve.

### B. Design Options

#### B.1 19000 MS & DA Safety Relief Valves

##### O-Ring Seat Seal Valves

All 19000 Series Valves are available with an O-Ring seat seal as a design option. This optional design is bubble tight at 97 percent of set pressures over 100 psig (6.89 barg), in order to meet application requirements beyond the normal capabilities of metal to metal seat valves. Consolidated Series 19000 valves with the O-Ring seat seal option are identified by the suffix DA. (See Table 14.)

##### Lifting Levers, Caps and Gags

All 19000 Series Valves are designed so that field conversion from the standard screwed cap to a plain lifting lever cap, or to a packed lifting lever cap (or vice versa), does not require valve disassembly or resetting. The lifting lever option is designed

to open the valve at 75 percent of the valve set pressure, in compliance with ASME Code Section VIII. Further, all available 19000 Series Valve caps may be equipped with a gag upon customer request.

##### Inlet/Outlet Connections

All 19000 Series Valves can be provided by GE Consolidated with flanged, or socket weld inlet and outlet connections, upon customer request.

#### B.2 19096M-DA-BP Safety Relief Valves (See Figure 6)

In this design, the bonnet and the spindle are different—there are two added parts and two additional O-Rings. The bonnet is a two-piece design rather than a one-piece. The top of the bonnet (7) is the male piece and it screws into the female bottom bonnet (8). The bottom bonnet has a machined shelf in the top on which a metal backup plate (39) seats via an O-Ring (40), part number 310XX030. (The “XX” in the part number designates the material and durometer of the O-Ring.) The spindle (9) is modified to have a larger diameter in the lower section to accommodate a 310XX011 O-Ring (40), which slides through the inside diameter of the backup plate (39), providing an area nearly equal to the area of the base which balances the effects of the back pressure.

### C. Nomenclature

Applicable valve nomenclature for Types 19000 Male and Female inlet configurations are illustrated in Figures 1 through 6. Relevant parts nomenclature for optional lifting levers, caps and the gag, as applicable, are provided in Figures 1 through 6.

# IX. Introduction

## A. 19000 MS & DA Safety Relief Valves

Consolidated Series 19000 Portable Pressure Relief Valves are designed to meet ASME Section VIII requirements for fixed blowdown pressure relief valves and liquid relief valves. They may be used for various media such as air, liquids, process steam and hydrocarbons and may serve as either a safety valve or a relief valve, depending upon the application.

## B. 19096M-DA-BP Safety Relief Valves

The 19000 back pressure version is only available in the .096" (2.44 mm) orifice with an O-Ring seat. It is available for steam, liquid or gas applications and may be furnished with a plain or screwed cap. The 19096M-DA-BP variation is furnished as a 19096M designation with a pressure range of 50-2000 psig (3.45-137.90 barg). The standard medium pressure valve is limited to a minimum of 290 psig (19.99 barg) in the standard 19000 design. The designation will be used since most of the parts are from the 19096M bill of material.

Table 1: Performance Criteria for the 19096M-DA-BP Valve	
Typical blowdown as a percent of set pressure (At the low end of the spring range with the maximum allowed back pressure applied, the blowdown is shortest.)	Liquid: 6 percent – 20 percent Gas: 3 percent – 16 percent
Allowable total back pressure (This is the sum of the variable and constant back pressure, superimposed and built-up.)	Liquid: 70 percent of set pressure Note: Thermal relief applications may be supplied with back pressures up to 90 percent of set pressure. Gas: 50 percent of set pressure Note: Total back pressure for liquid or gas shall not exceed 400 psig (27.58 barg).
Temperature limits (Determined by O-Ring material selection)	Minimum: -20°F (-28°C) Maximum: 600°F (315°C)
Seat tightness	Set pressure of 50 psig (3.45 barg): 92 percent 51 psig (3.52 barg) – 100 psig (6.8 barg): 94 percent 101 psig (6.9 barg) – Maximum Rating: 95 percent

Note: Refer to this Table for the performance criteria of this valve. Applications outside of these ranges may cause malfunction of the intended valve operation.

# X. Consolidated 19000 Series SRV

## A. Metal Seat Valve

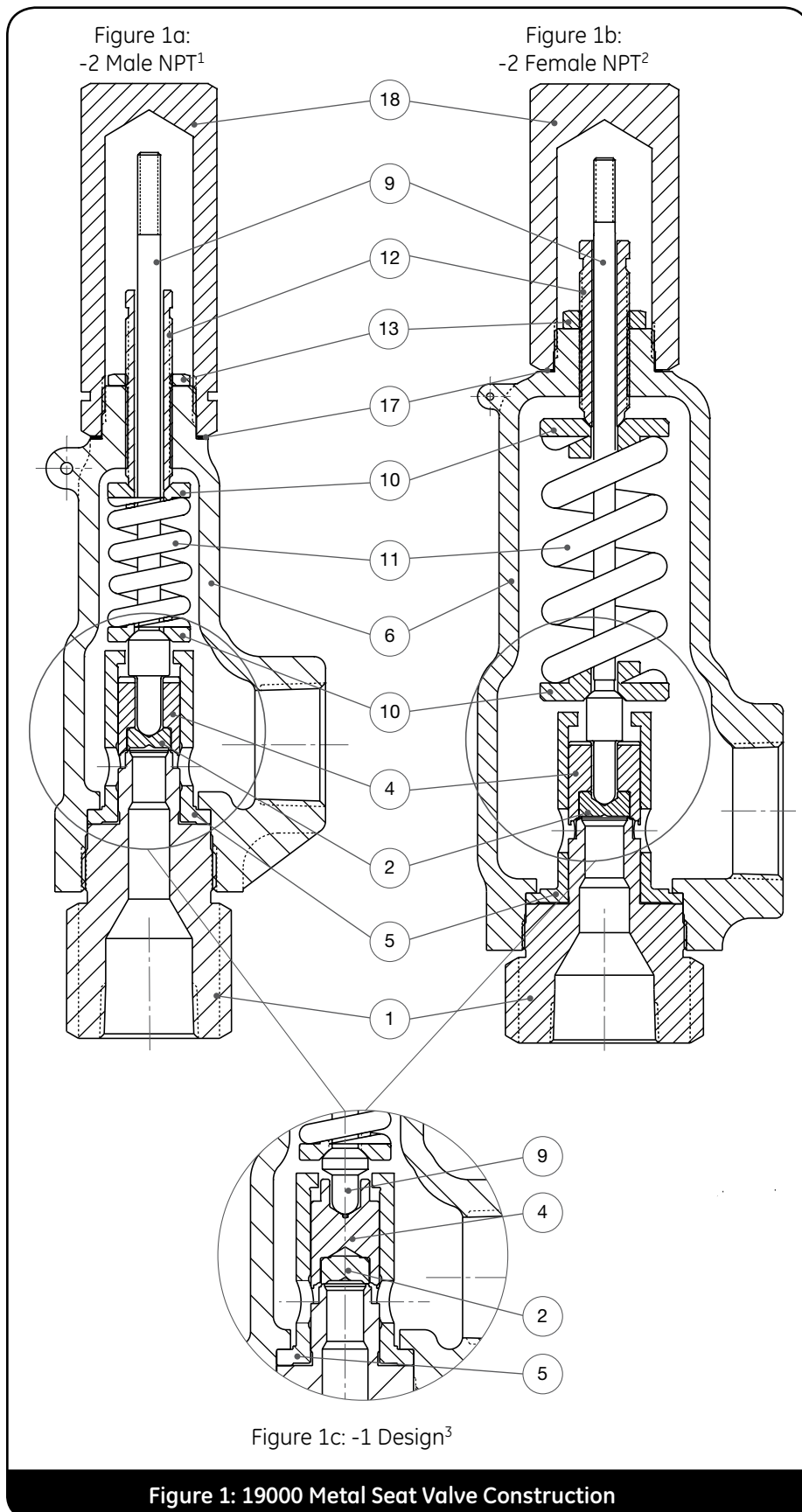

Part No.	Nomenclature
1	Base
2	Disc
4	Disc Holder
5	Guide
6	Bonnet
9	Spindle
10	Spring Washer
11	Spring
12	Adjusting Screw
13	Adj. Screw Locknut
17	Cap Gasket
18	Screwed Cap
32	Inlet Extension (Not Shown)
33	Inlet Flange (Not Shown)
34	Outlet Extension (Not Shown)
35	Outlet Flange (Not Shown)
41	Inlet Nipple Extension (Not Shown) (Optional)
42	Outlet Nipple Ext. (Not Shown) (Optional)

**Note 1**

Available as: 19096L, 19110L, 19126L, 19226L, 19096M, 19110M, 19126M, 19226M

**Note 2**

Available as: 19096L, 19110L, 19126L, 19226L, 19357L, 19567L, 19096M, 19110M, 19126M, 19226M, 19357M, 19567M, 19096H, 19110H, 19126H, 19226H

**Note 3**

19110 Valve Not Available.

# X. Consolidated 19000 Series SRV (Contd.)

## B. Optional Cap Types

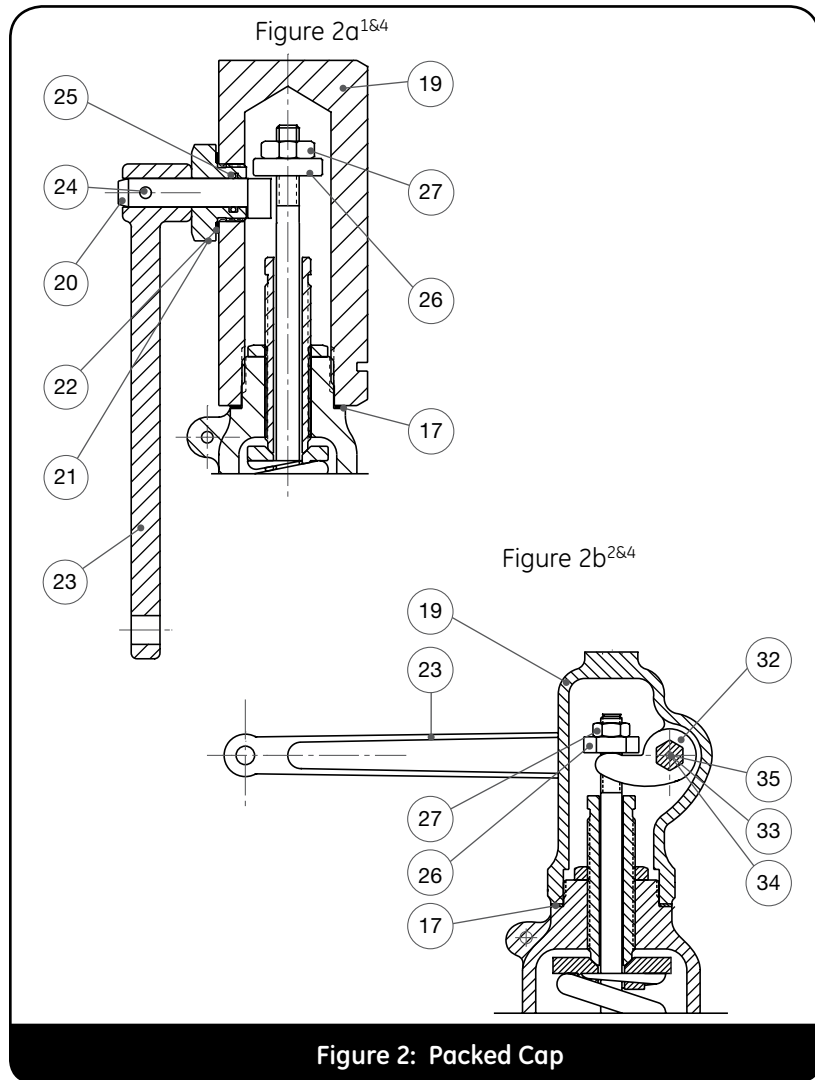

Figure 2: Packed Cap

Part No.	Nomenclature
14	Gag Bolt
15	Sealing Plug
16	Sealing Plug Gasket
17	Cap Gasket
19	Packed Cap
20	Cam Shaft
21	Bushing
22	Bushing Gasket
23	Packed Lifting Lever
24	Drive Pin
25	O-Ring
26	Release Nut
27	Release Locknut
28	Plain Lever Cap
29	Plain Lifting Lever
30	Cap Screw
31	Lever Pin
32	Lifting Fork
33	Lever Shaft
34	Packing
35	Packing Nut

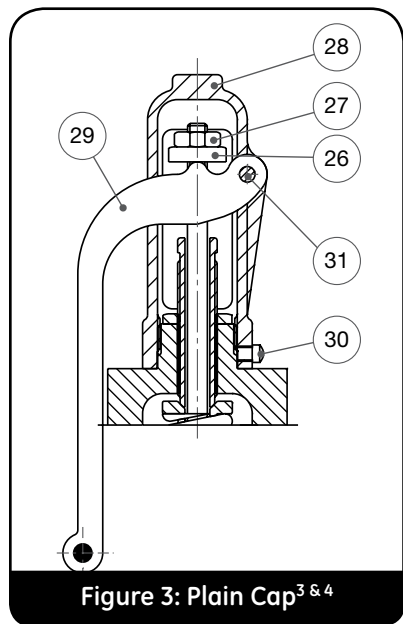

Figure 3: Plain Cap<sup>3 & 4</sup>

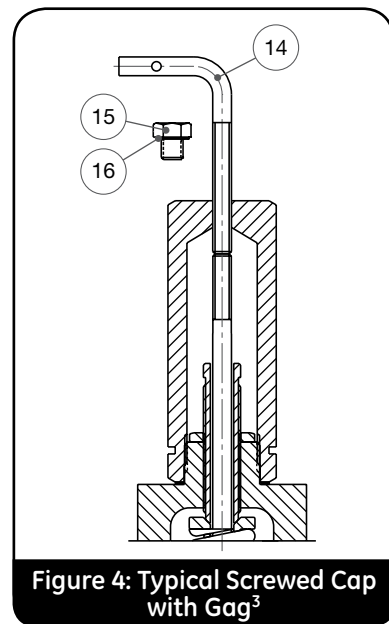

Figure 4: Typical Screwed Cap with Gag<sup>3</sup>

**Note 1**  
Available for: 19096L, M & H; 19110L, M & H; 19126L & M; 19226L & M. Excludes 19096M-DA-BP

**Note 2**  
Available for: 19126H; 19226H; 19357L & M; 19357L & M; Excludes 19096M-DA-BP

**Note 3**  
Available for all 19000 valves

**Note 4**  
Can be provided with a gag if required

# X. Consolidated 19000 Series SRV (Contd.)

## C. Soft Seat Valve

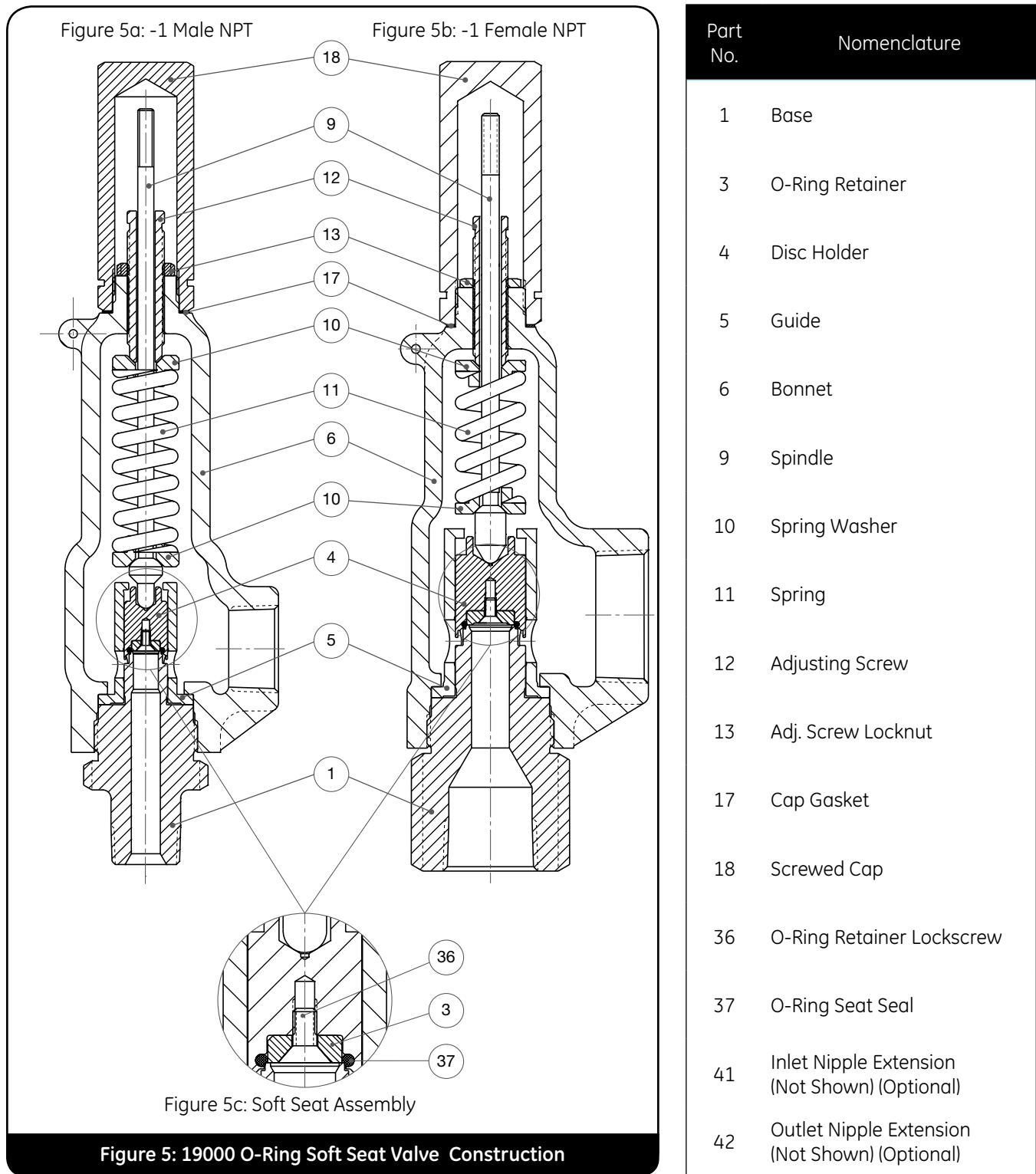



# X. Consolidated 19000 Series SRV (Contd.)

## D. The 19096M-DA-BP Valve

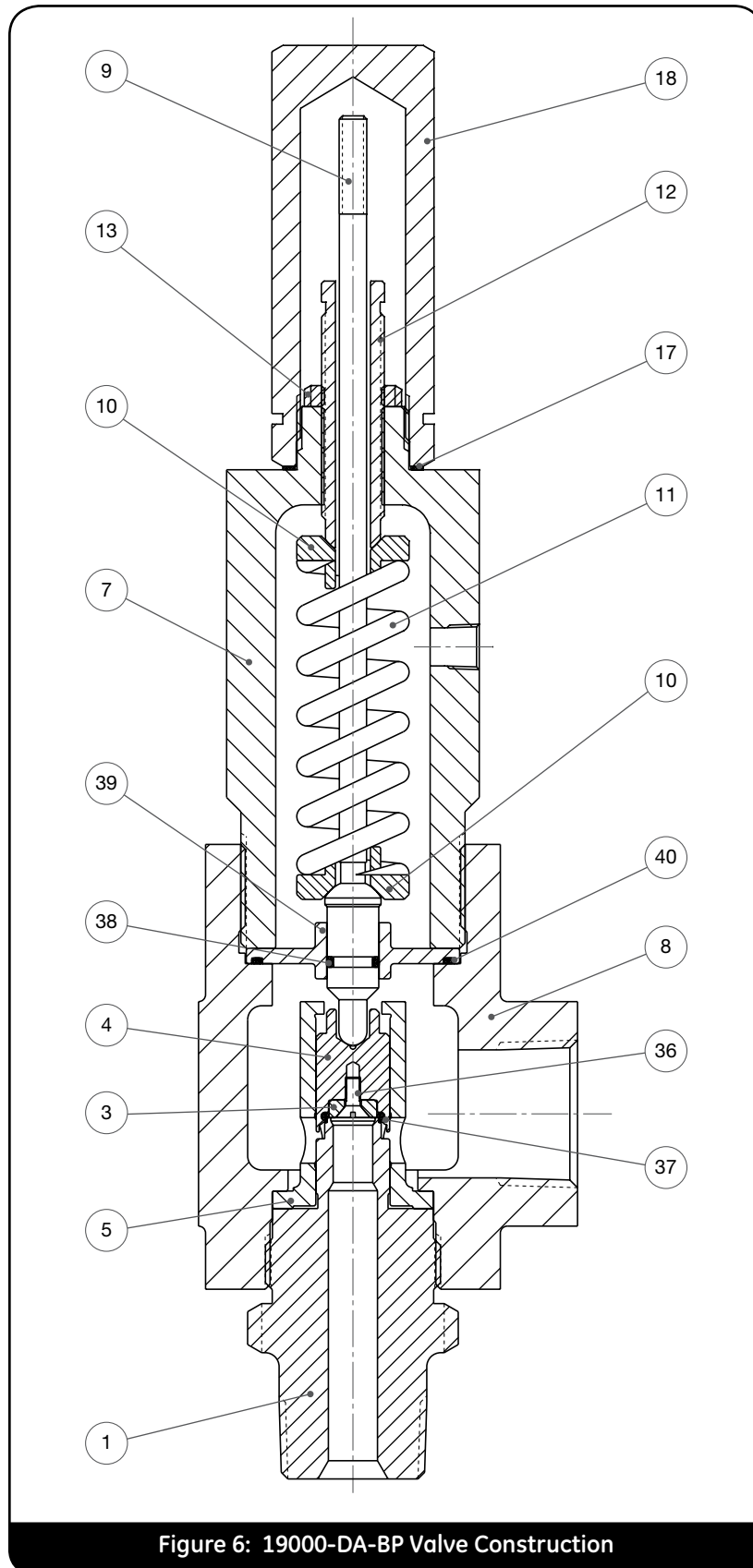

Part No.	Nomenclature
1	Base
3	O-Ring Retainer
4	Disc Holder
5	Guide
7	Bonnet Top
8	Bonnet Bottom
9	Spindle
10	Spring Washer
11	Spring
12	Adjusting Screw
13	Adj. Screw Locknut
17	Cap Gasket
18	Screwed Cap
36	O-Ring Retainer Lockscrew
37	O-Ring Seat Seal
38	Spindle O-Ring
39	Backup Plate
40	Backup Plate O-Ring

Figure 6: 19000-DA-BP Valve Construction

# XI. Recommended Installation Practices

**⚠ DANGER**

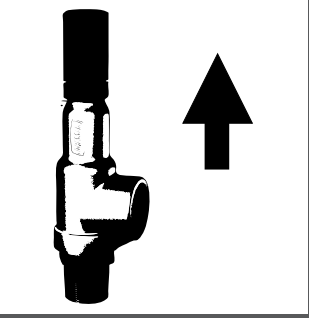

Mount safety relief valves in a vertical, upright position only.

**⚠ DANGER**

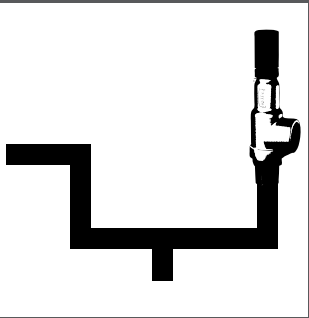

Do not mount valve at the end of pipe through which there is normally no flow or near elbows, tees, bends, etc.

**⚠ CAUTION**



Heed all service manual warnings. Read installation instructions before installing valve(s).

## A. Mounting Position

Mount SRVs in a vertical (upright) position (in accordance with API RP 530). Installing a safety relief valve in any position other than vertical ( $\pm 1$  degree) will adversely affect its operation as a result of the induced misalignment of moving parts.

A stop valve may be placed between the pressure vessel and its relief valve only as permitted by code regulations. If a stop valve is located between the pressure vessel and SRV, the stop valve port area should equal or exceed the nominal internal area associated with the pipe size of the SRV inlet. The pressure drop from the vessel to the SRV shall not exceed 3 percent of the valve's set pressure, when flowing at full capacity.

The threaded inlet and outlet ports and sealing faces of the valve and all connecting piping must be free from dirt, sediment and scale.

In the case of screwed/portable valves, use caution to avoid unscrewing bonnet from the base; if a pipe wrench is used to install or remove the base, ensure that the wrench is placed on the flats of the base and not on the bonnet. If the bonnet/ base joint is broken, the valve should be retested to ensure proper set pressure and function of the valve.

Position SRVs for easy access and/or removal so that servicing can be properly performed. Ensure sufficient working space is provided around and above the valve.

## B. Inlet Piping

The inlet piping (see Figure 7) to the valve should be short and directly from the vessel or equipment being protected. The radius of the connection to the vessel should permit smooth flow to the valve. Avoid sharp corners. If this is not practical, then the inlet should be at least one additional pipe diameter larger.

The pressure drop from the vessel to the valve shall not exceed 3 percent of valve set pressure when the valve is allowing full capacity flow. The inlet piping should never be smaller in diameter than the inlet connection of the valve. Excessive pressure drop in gas, vapor, or flashing-liquid service at the inlet of the SRV will cause the extremely rapid opening and closing of the valve, which is known as "chattering." Chattering will result in lowered capacity and damage to the seating surfaces. The most desirable installation is that in which the nominal size of the inlet piping is the same as, or greater than, the nominal size of the valve inlet flange and in which the length does not exceed the face-to-face dimensions of a standard tee of the required pressure class.

Do not locate SRV inlets where excessive turbulence is present, such as near elbows, tees, bends, orifice plates or throttling valves.

Section VIII of the ASME Boiler and Pressure Vessel Code requires the inlet connection design to consider stress conditions during valve operation, caused by external loading, vibration, and loads due to thermal expansion of the discharge piping.

The determination of reaction forces during valve discharge is the responsibility of the vessel and/or piping designer. GE publishes certain technical information about reaction forces under various fluid flow conditions, but assumes no liability for the calculations and design of the inlet piping.

External loading, by poorly designed discharge piping and support systems, and forced alignment of discharge piping can cause excessive stresses and distortions in the valve as well as the inlet piping. The stresses in the valve may cause a malfunction or leak. Therefore,

# XI. Recommended Installation Practices (Contd.)

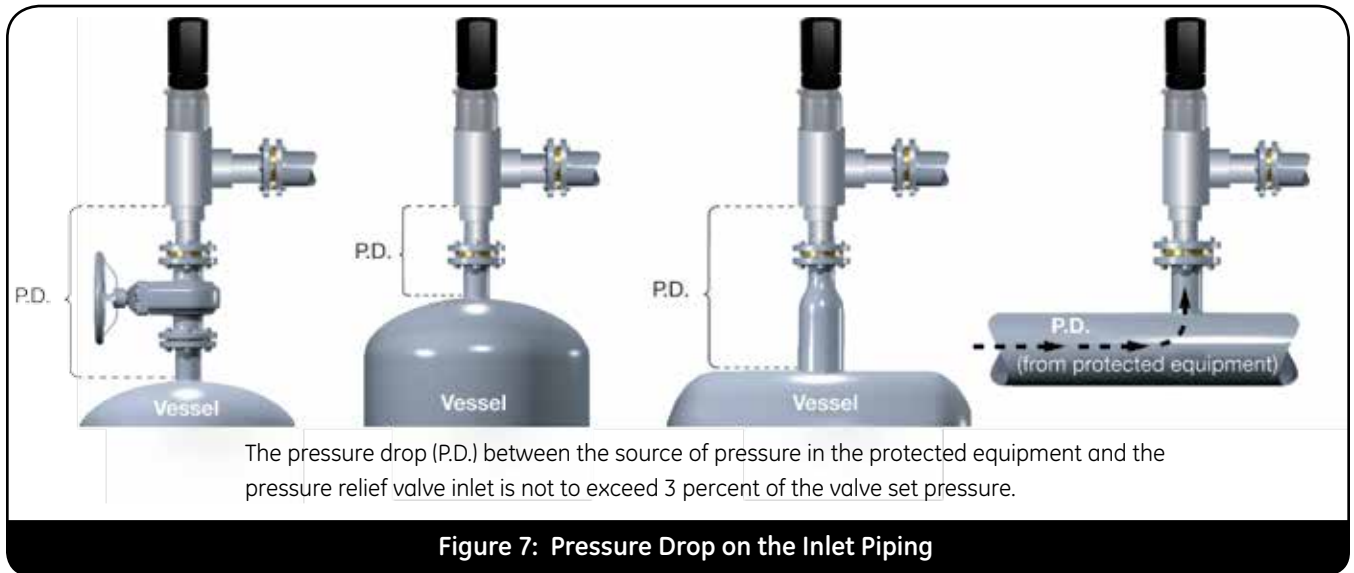

discharge piping must be independently supported and carefully aligned.

Vibrations in the inlet piping systems may cause valve seat leakage and/or fatigue failure. These vibrations may cause the disc seat to slide back and forth across the base seat and may result in damage to the seating surfaces. Also, vibration may cause separation of the seating surfaces and premature wear to valve parts. High-frequency vibrations are more detrimental to SRV tightness than low-frequency vibrations. This effect can be minimized by providing a larger difference between the operating pressure of the system and the set pressure of the valve, particularly under high frequency conditions.

Temperature changes in the discharge piping may be caused by fluid flow in from the discharge of the valve or by prolonged exposure to the sun or heat radiated from nearby equipment.

A change in the discharge piping temperature will cause a change in the length of the piping, which may cause stresses to be transmitted to the SRV and its inlet piping. Proper support, anchoring or provision for flexibility of the discharge piping can prevent stresses caused by thermal changes. Do not use fixed supports.

## C. Outlet Piping

Alignment of the internal parts of the SRV is important to ensure proper operation (see Figure 8). Although the valve body will withstand a considerable

mechanical load, unsupported discharge piping consisting of more than a companion flange long-radius elbow, and a short vertical pipe is not recommended. Use spring supports to connect outlet piping to prevent thermal expansion from creating strains on the valve. The discharge piping should be designed to allow for vessel expansion as well as expansion of the discharge pipe itself. This is particularly important on long distance lines.

A continual oscillation of the discharge piping (wind loads) may induce stress distortion in the valve body. The resultant movement of the valve's internal parts may cause leakage.

Where possible, use properly supported drainage piping to prevent the collection of water or corrosive liquid in the valve body.

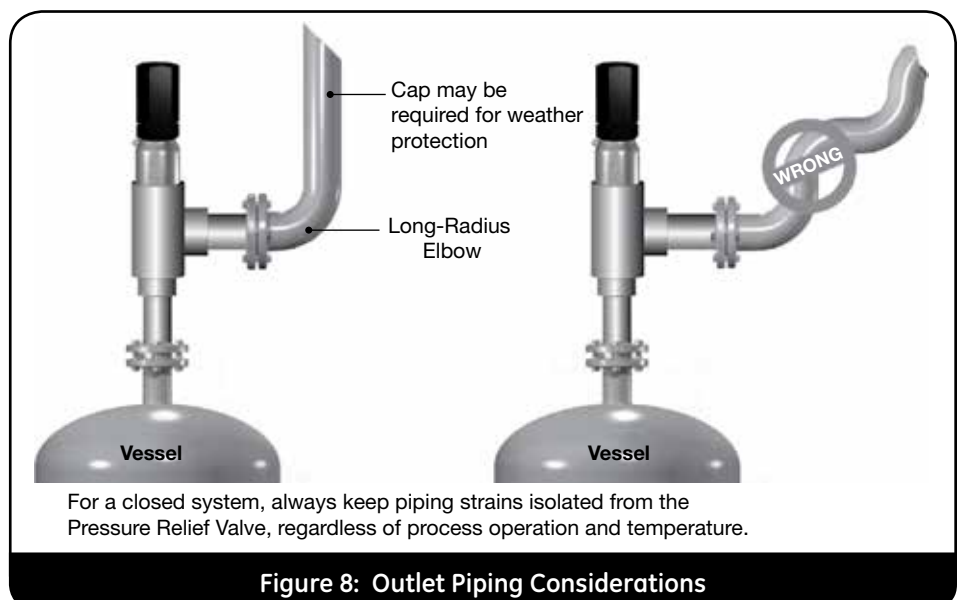

# XI. Recommended Installation Practices (Contd.)

When two or more valves are piped to discharge into a common header, the built-up backpressure resulting from the opening of one (or more) valve(s) may cause a superimposed backpressure in the remaining valves. Under these conditions, the use of the 19096-DA-BP model is recommended.

In every case, the nominal discharge pipe size should be at least as large as the nominal size of the SRV outlet flange. In the case of long discharge piping, the nominal discharge pipe size must sometimes be much larger.

As a final point, the discharge piping size is never less than the size of the valve outlet, nor heavier than schedule 40 pipe size. In addition, the discharge piping must be designed to limit the total backpressure to a maximum of 10 percent of the valve set pressure, or 400 psig (27.58 barg), whichever is smaller.

**ATTENTION!**

Undersized discharge piping could create built-up backpressure.

# XII. Disassembly of 19000 Series SRV

## A. General Information

Consolidated SRVs can be easily disassembled for inspection, the reconditioning of seats or the replacement of internal parts. Appropriate set pressure can be established after reassembly. (See Figures 1 through 6 for parts nomenclature.)

Notes:

- Before starting to disassemble the valve, be sure there is no media pressure in the vessel.
- Many pressure vessels that are protected by Consolidated safety relief valves contain dangerous materials.
- Decontaminate and clean the valve inlet and outlet and clean the valve inlet and outlet and all external surfaces in accordance with the cleaning and decontaminating recommendations in the appropriate Material Safety Data sheet.
- Parts from one valve should not be interchanged with parts from another valve.

**ATTENTION!**

Do not interchange parts from one valve with parts from another valve.

**CAUTION**



Wear necessary protective equipment to prevent possible injury

**DANGER**

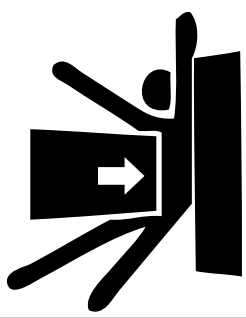

Before disassembling the valve, ensure there is no media pressure in the vessel.

**DANGER**

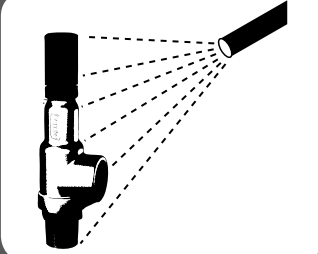

Many pressure vessels protected by Consolidated safety relief valves contain dangerous materials. Decontaminate and clean the valve inlet, outlet, and all external surfaces in accordance with the cleaning and decontaminating recommendations in the appropriate Material Safety Data Sheet.

**CAUTION**

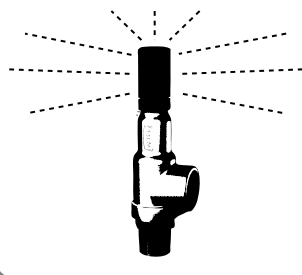

Valve caps and bonnets can trap fluids. Use caution when removing to prevent injury or environmental damage.

## XII. Disassembly of 19000 Series SRV (Contd.)

### B. Disassembly

#### B.1 Metal Seat Valves (See Figure 1)

- a. Remove the cap (18) (including lifting gear, if any); then, remove the cap (17) gasket.
- b. Measure the position of the valve adjusting screw (12) and record before removal. Measure from the top of the screw to the adjusting screw locknut (13).
- c. Loosen the adjusting screw locknut (13) and remove the adjusting screw (12) from the bonnet (6).
- d. Unscrew the bonnet (6) from the base (1).
- e. Remove the spindle (9), spring (11), and spring washers (10).
- f. Remove the guide (5), disc holder (4), and disc (2) from the base (1).

#### B.2 O-Ring Seat Seal Valves (DA) (See Figure 5)

Follow steps (a) through (e) for Metal Seat Valves above.

- f. Remove the guide (5) and O-Ring disc holder assembly from the base.
- g. Remove the o-ring retainer lock screw (36) and the O-Ring retainer (3).
- h. Carefully remove the O-Ring Seat Seal (37). Be sure not to damage the O-Ring groove in the disc holder (4).

#### B.3 19096M-DA-BP Valves (See Figure 6)

- a. Remove the cap (18) (including lifting gear, if any); then remove the cap gasket (17).
- b. Measure the position of the valve adjusting screw (12) and record before removal. Measure from the top of the screw to the adjusting screw locknut (13).
- c. Loosen the adjusting screw locknut (13) and remove the adjusting screw (12) from the bonnet top (7). (d) Unscrew the bonnet top (7) from the bonnet bottom (8).

- e. Remove the spindle (9), backup plate (39), spring (11) and spring washers (10).
- f. Unscrew the bonnet bottom (7) from the base (1).
- g. Remove the guide (5) and O-Ring retainer (3).
- h. Remove the retainer lock screw (36) and the O-Ring retainer (3).
- i. Carefully remove the seat O-Ring (37). Be sure not to damage the O-Ring groove in the disc holder (4)

### C. Cleaning

19000 Series Safety Relief Valve internal parts may be cleaned with industrial solvents, cleaning solutions and wire brushes.

If you are using cleaning solvents, take precautions to protect yourself from potential danger from breathing fumes, chemical burns or explosion. See the solvent's Material Safety Data Sheet for safe handling recommendations and equipment. It is not recommended to "sandblast" internal parts as it can reduce the dimensions of the parts. The base (1), bonnet (6) and cap (18) castings may be sandblasted with care not to erode internal surfaces or damage machined surfaces. If grit blasting is required, the use of glass bead media is recommended.



# XIII. Maintenance

## A. Metal Seat Valves (MS)

### A1. Precautions and Hints for Lapping Seats

Reconditioning of the seat surface may be accomplished by lapping with a flat cast iron ring lap coated with a 1000 grit lapping compound or its equivalent (see Table 17). A cast iron lap, coated with a lapping compound, is used for reconditioning the seating surfaces of the base (1) and disc (2). will enable maintenance personnel to do a "professional" job of lapping seats:

1. Keep work materials clean.
2. Always use a fresh lap. If signs of wearing (out of flatness) are evident, recondition the lap. Reconditioning of laps is accomplished by lapping them on a flat lapping plate. The lapping should be done with a figure-eight motion as indicated in Figure 9. To assure the best results when lapping seats, the laps should be reconditioned after each usage.
3. Apply a very thin layer of compound to the lap. This will prevent rounding off the edges of the seat.
4. Keep the lap squarely on the flat surface and avoid any tendency to rock the lap which causes rounding of the seat.
5. When lapping, keep a firm grip on the part to prevent the possibility of dropping it and damaging the seat.
6. Lap, using an eccentric, or figure-eight motion, in all directions, while at the same time, applying uniform pressure and rotating the lap slowly (see Figure 9).
7. Replace the compound frequently after wiping off the old compound, and apply more pressure to speed the cutting action of the compound.
8. To check the seating surfaces, remove all compounds from both the seat and the lap. Then, shine the seat with the

same lap using the lapping motion described above. Low sections on the seating surface will show up as a shadow in contrast to the shiny portion. If shadows are present, further lapping is necessary and only laps known to be flat should now be used. Only a few minutes will be required to remove the shadows.

9. When the lapping is completed, any lines appearing as cross scratches can be removed by rotating the lap (which has been wiped clean of compounds) on the seat about its own axis.
10. The seat should now be thoroughly cleaned using a lint-free cloth and a cleansing fluid.

### A2. Lapping the Base Seat

#### For -1 design

The base seat may be reconditioned using the lapping procedure; however, the dimensions provided in Table 2, should be used to determine the seat width.

SET PRESSURE				SEAT WIDTH	
psig		barg		in.	mm
min.	max.	min.	max.		
5	100	0.34	6.89	.010	0.25
101	300	6.96	20.68	.015	0.38
301	800	20.75	55.16	.020	0.51
801	UP	55.23	UP	Note 1	

Note 1: Add .005" (0.125 mm) per 100 psig (6.9 barg), not to exceed .070" (1.78 mm).

The seat width can be measured by the use of a "Measuring Magnifier" (see Figure 10a). GE Consolidated recommends the use of Model S1-34-35-37 (Bausch and Lomb Optical Co.) or an equivalent. This is a seven power glass with a .750" (19.05 mm) scale showing graduations of .005" (0.13 mm). The use of this scale in measuring the seat width is shown in Figure 10b.

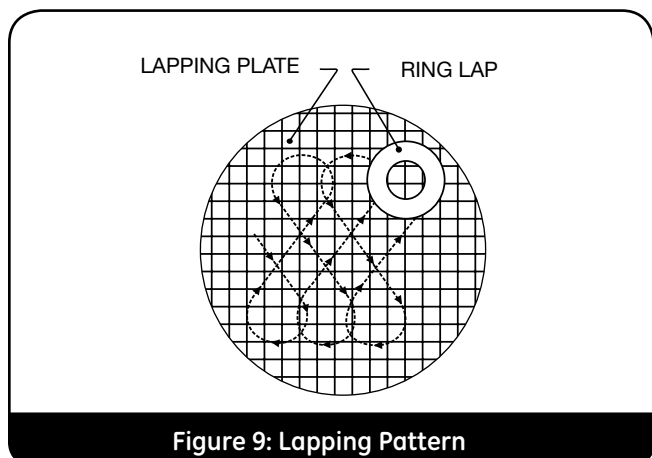

Figure 9: Lapping Pattern

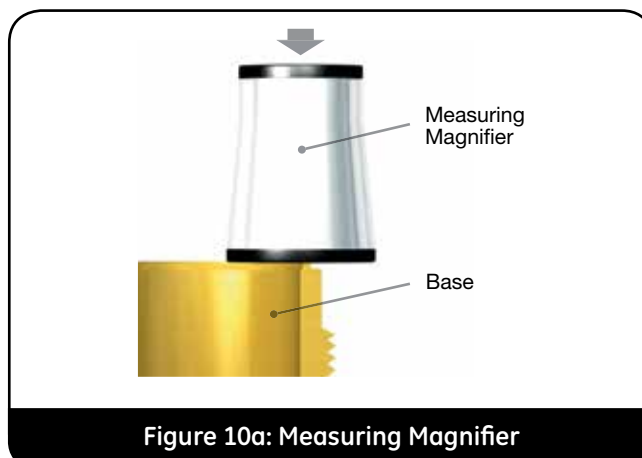

Figure 10a: Measuring Magnifier

# XIII. Maintenance (Contd.)

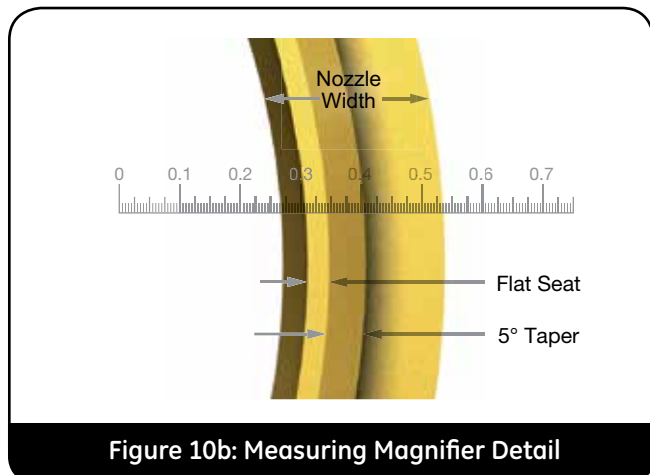

Figure 10b: Measuring Magnifier Detail

## For -2 Design

The -2 metal seat design is a flat seat design. The base seat may be lapped or machined if necessary to verify that the seat ("N" of Figure 11) is free from indentions, scratches, high spots, etc.

If additional lighting is required for verifying the seat, GE suggests a goose-neck flashlight similar to the Type A Lamp Assembly Flashlight (Standard Molding Corporation, Dayton, Ohio) or an equivalent.

## A3. Machining the Base Seat

1. When the base seat cannot be repaired by lapping, it can be machined as shown in Figure 11, using the dimensions provided in Tables 3 to 5.
2. GE recommends that the following procedure be adhered to when machining the base seat:
  - a. Using a four-jaw chuck, align the base so that surfaces marked X and U run true within .001" (0.03 mm) on an indicator.
  - b. Take light cuts on the seat surface until all damage is removed. Reestablish dimensions "B", "C", "F", "G", "H" and Angle I. When L (minimum) is obtained, the base should be replaced.
  - c. After all machining has been accomplished, lap the seat using same procedure for base seat.

**ATTENTION!**

19000H and 19000 DA bases have flat seats (90° angle) across the entire seating surface from B diameter to D diameter.

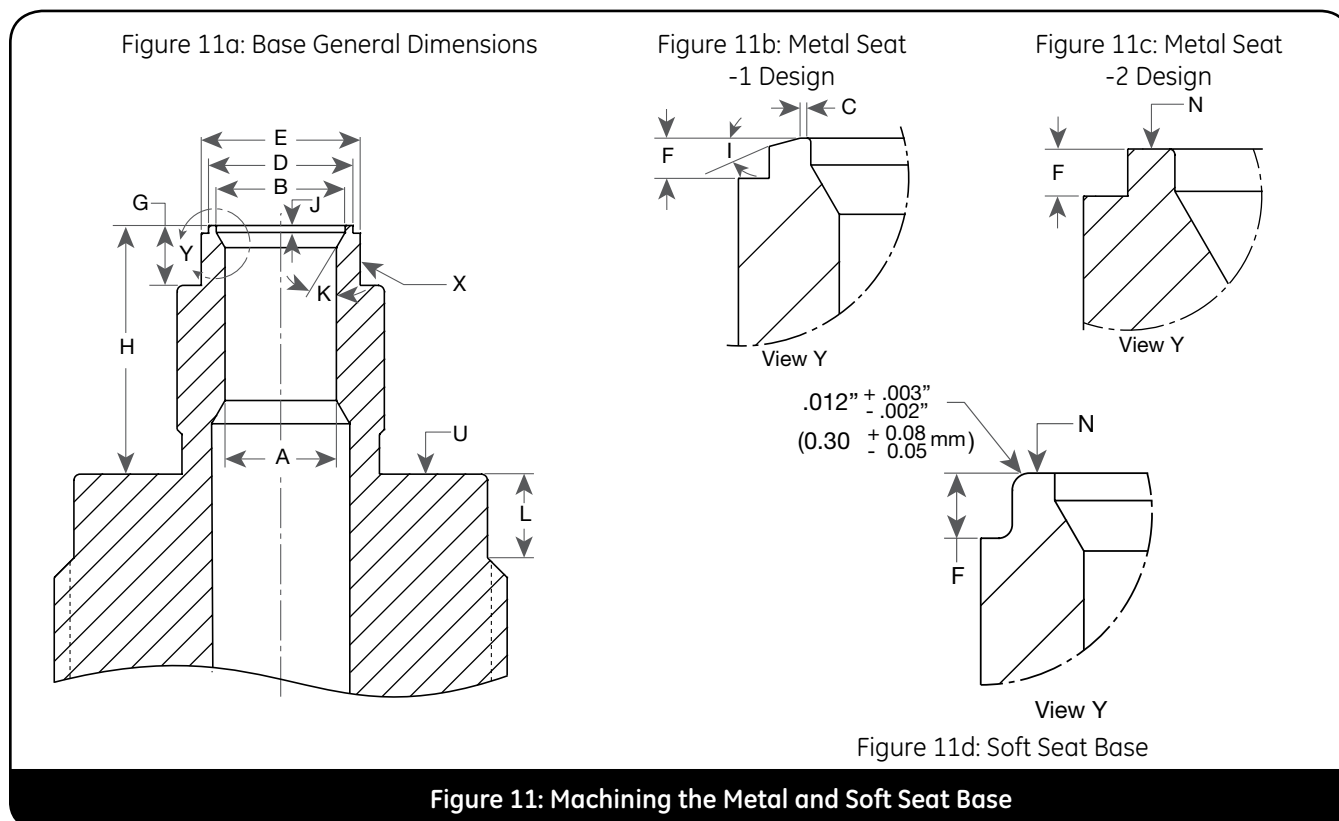

Figure 11: Machining the Metal and Soft Seat Base

## XIII. Maintenance (Contd.)

**Table 3: 19000-1 Series Metal Seat (MS) Base Re-work Dimensions**

Valve Type	A min.		B ± .002" (± 0.05 mm)		C min.		D ± .002" (± 0.05 mm)		E ± .003" (± 0.08 mm)		F ± .005" (± 0.13 mm)	
	in.	mm	in.	mm	in.	mm	in.	mm	in.	mm	in.	mm
19096L	.350	8.89	.395	10.03	.010	0.25	.457	11.61	.503	12.78	.030	0.76
19126L	.401	10.19	.453	11.51	.010	0.25	.523	13.28	.579	14.71	.030	0.76
19226L	.537	13.64	.606	15.39	.010	0.25	.701	17.81	.781	19.84	.030	0.76
19357L	.675	17.15	.762	19.35	.010	0.25	.881	22.38	.987	25.07	.038	0.97
19567L	.850	21.59	.960	24.38	.010	0.25	1.109	28.17	1.247	31.67	.048	1.22
19096M	.350	8.89	.395	10.03	.010	0.25	.457	11.61	.503	12.78	.030	0.76
19126M	.401	10.19	.453	11.51	.010	0.25	.523	13.28	.579	14.71	.030	0.76
19226M	.537	13.64	.606	15.39	.010	0.25	.701	17.81	.781	19.84	.038	0.97
19357M	.675	17.15	.762	19.35	.010	0.25	.881	22.38	.987	25.07	.038	0.97
19567M	.850	21.59	.960	24.38	.010	0.25	1.109	28.17	1.247	31.67	.048	1.22
19096H	.350	8.89	.395	10.03	Flat	Flat	.457	11.61	.503	12.78	.030	0.76
19126H	.401	10.19	.453	11.51	Flat	Flat	.523	13.28	.579	14.71	.030	0.76
19226H	.537	13.64	.606	15.39	Flat	Flat	.701	17.81	.781	19.84	.030	0.76

**Table 3: 19000-1 Series Metal Seat (MS) Base Re-work Dimensions (Contd.)**

Valve Type	G ± .005" (± 0.13 mm)		H + .002/ - .003" (+ 0.05/- 0.08 mm)		I (angle)	J ± .005" (± 0.13 mm)		K (angle)	L min.	
	in.	mm	in.	mm		in.	mm		in.	mm
19096L	.188	4.78	.784	19.91	15°	.020	0.51	30°	.188	4.78
19126L	.216	5.49	.784	19.91	15°	.023	0.58	30°	.188	4.78
19226L	.289	7.34	1.034	26.26	15°	.030	0.76	30°	.187	4.75
19357L	.363	9.22	1.502	38.15	5°	.038	0.97	30°	.250	6.35
19567L	.457	11.61	1.502	38.15	5°	.048	1.22	30°	.250	6.35
19096M	.188	4.78	.784	19.91	15°	.030	0.76	30°	.187	4.75
19126M	.216	5.49	.784	19.91	15°	.030	0.76	30°	.187	4.75
19226M	.289	7.34	1.034	26.26	15°	.038	0.97	30°	.187	4.75
19357M	.363	9.22	1.502	38.15	5°	.038	0.97	30°	.250	6.35
19567M	.457	11.61	1.502	38.15	5°	.048	1.22	30°	.250	6.35
19096H	.188	4.78	1.034	26.26	Flat	.030	0.76	30°	.187	4.75
19126H	.156	3.96	1.524	38.71	Flat	.030	0.76	30°	.250	6.35
19226H	.210	5.33	1.504	38.20	Flat	.030	0.76	30°	.250	6.35



# XIII. Maintenance (Contd.)

**Table 4: 19000-2 Series Metal Seat (MS) Base Re-work Dimensions**

Valve Type	A min.		B ± .002" (± 0.05 mm)		C min.	D ± .002" (± 0.05 mm)		E ± .003" (± 0.08 mm)		F ± .002" (± 0.05 mm)	
	in.	mm	in.	mm		in.	in.	mm	in.	mm	in.
19096L	.350	8.89	.408	10.36	N/A	.457	11.61	.503	12.78	.025	0.64
19110L	.375	9.53	.408	10.36	N/A	.457	11.61	.503	12.78	.025	0.64
19126L	.401	10.19	.463	11.76	N/A	.523	13.28	.579	14.71	.024	0.61
19226L	.537	13.64	.625	15.88	N/A	.701	17.81	.781	19.84	.022	0.56
19357L	.675	17.15	.796	20.22	N/A	.881	22.38	.987	25.07	.022	0.56
19567L	.850	21.59	1.000	25.40	N/A	1.109	28.17	1.247	31.67	.022	0.56
19096M	.350	8.89	.408	10.36	N/A	.457	11.61	.503	12.78	.025	0.64
19110M	.375	9.53	.408	10.36	N/A	.457	11.61	.503	12.78	.025	0.64
19126M	.401	10.19	.463	11.76	N/A	.523	13.28	.579	14.71	.024	0.61
19226M	.537	13.64	.625	15.88	N/A	.701	17.81	.781	19.84	.025	0.64
19357M	.675	17.15	.796	20.22	N/A	.881	22.38	.987	25.07	.024	0.61
19567M	.850	21.59	1.000	25.40	N/A	1.109	28.17	1.247	31.67	.024	0.61
19096H	.350	8.89	.395	10.03	N/A	.457	11.61	.503	12.78	.022	0.56
19110H	.375	9.53	.395	10.03	N/A	.457	11.61	.503	12.78	.022	0.56
19126H	.401	10.19	.444	11.28	N/A	.523	13.28	.579	14.71	.022	0.56
19226H	.537	13.64	.616	15.65	N/A	.701	17.81	.781	19.84	.022	0.56

**Table 4: 19000-2 Series Metal Seat (MS) Base Re-work Dimensions (Contd.)**

Valve Type	G ± .005" (± 0.13 mm)		H + .002/- .003" (+ 0.05/- 0.08 mm)		I (angle)	J ± .005" (± 0.13 mm)		K (angle)	L min.	
	in.	mm	in.	mm		in.	mm		in.	mm
19096L	.190	4.83	.786	19.96	Flat	.022	0.56	30°	.187	4.75
19110L	.190	4.83	.786	19.96	Flat	.022	0.56	30°	.187	4.75
19126L	.218	5.54	.784	19.91	Flat	.025	0.64	30°	.187	4.75
19226L	.289	7.34	1.034	26.26	Flat	.030	0.76	30°	.187	4.75
19357L	.363	9.22	1.502	38.15	Flat	.038	0.97	30°	.250	6.35
19567L	.457	11.61	1.502	38.15	Flat	.048	1.22	30°	.250	6.35
19096M	.122	3.10	.790	20.07	Flat	.022	0.56	30°	.187	4.75
19110M	.122	3.10	.790	20.07	Flat	.022	0.56	30°	.187	4.75
19126M	.127	3.23	.790	20.07	Flat	.025	0.64	30°	.187	4.75
19226M	.212	5.38	1.037	26.34	Flat	.032	0.81	30°	.187	4.75
19357M	.246	6.25	1.550	39.37	Flat	.040	1.02	30°	.250	6.35
19567M	.302	7.67	1.574	39.98	Flat	.050	1.27	30°	.250	6.35
19096H	.120	3.05	1.038	26.37	Flat	.030	0.76	30°	.187	4.75
19110H	.120	3.05	1.038	26.37	Flat	.030	0.76	30°	.187	4.75
19126H	.125	3.18	1.502	38.15	Flat	.030	0.76	30°	.250	6.35
19226H	.210	5.33	1.504	38.20	Flat	.030	0.76	30°	.250	6.35

# XIII. Maintenance (Contd.)

**Table 5: 19000 Series Soft Seat (DA) Base Re-work Dimensions**

Valve Type	A min.		B ±.002" (±0.05 mm)		C min.	D ±.002" (±0.05 mm)		E ±.003" (±0.08 mm)		F <sup>1</sup> ±.005" (±0.13 mm)	
	in.	mm	in.	mm		in.	mm	in.	mm	in.	mm
19096L	.350	8.89	.395	10.03	Flat	.457	11.61	.503	12.78	.050	1.27
19110L	.375	9.53	.395	10.03	Flat	.457	11.61	.503	12.78	.050	1.27
19126L	.401	10.19	.453	11.51	Flat	.523	13.28	.579	14.71	.050	1.27
19226L	.537	13.64	.606	15.39	Flat	.701	17.81	.781	19.84	.054	1.37
19357L	.675	17.15	.762	19.35	Flat	.293	7.44	.987	25.07	.062	1.57
19567L	.850	21.59	.960	24.38	Flat	1.109	28.17	1.247	31.67	.062	1.57
19096M	.350	8.89	.395	10.03	Flat	.457	11.61	.503	12.78	.050	1.27
19110M	.375	9.53	.395	10.03	Flat	.457	11.61	.503	12.78	.050	1.27
19126M	.401	10.19	.453	11.51	Flat	.523	13.28	.579	14.71	.082	2.08
19226M	.537	13.64	.606	15.39	Flat	.701	17.81	.781	19.84	.084	2.13
19357M	.675	17.15	.762	19.35	Flat	.893	22.68	.987	25.07	.092	2.34
19567M	.850	21.59	.960	24.38	Flat	1.109	28.17	1.247	31.67	.128	3.25
19096H	.350	8.89	.395	10.03	Flat	.457	11.61	.503	12.78	.048	1.22
19110H	.375	9.53	.395	10.03	Flat	.457	11.61	.503	12.78	.048	1.22
19126H	.401	10.19	.453	11.51	Flat	.523	13.28	.579	14.71	.048	1.22
19226H	.537	13.64	.606	15.39	Flat	.701	17.81	.781	19.84	.052	1.32

**Table 5: 19000 Series Soft Seat (DA) Base Re-work Dimensions (Contd.)**

Valve Type	G ±.005" (±0.13 mm)		H + .002/- .003" (+ 0.05/- 0.08 mm)		I (angle)	J ±.005" (±0.13 mm)		K (angle)	L min.		M Liquid Valve only <sup>1</sup> + .002/- .003" (+ 0.05/- 0.08 mm)	
	in.	mm	in.	mm		in.	mm		in.	mm	in.	mm
19096L	.190	4.83	.786	19.96	Flat	.022	0.56	30°	.187	4.75	.032	0.81
19110L	.190	4.83	.786	19.96	Flat	.022	0.56	30°	.187	4.75	.050	1.27
19126L	.218	5.54	.786	19.96	Flat	.025	0.64	30°	.187	4.75	.032	0.81
19226L	.291	7.39	1.036	26.31	Flat	.032	0.81	30°	.187	4.75	.032	0.81
19357L	.363	9.22	1.503	38.18	Flat	.038	0.97	30°	.250	6.35	.040	1.02
19567L	.457	11.61	1.503	38.18	Flat	.048	1.22	30°	.250	6.35	.050	1.27
19096M	.190	4.83	.812	20.62	Flat	.032	0.81	30°	.187	4.75	N/A	N/A
19110M	.190	4.83	.812	20.62	Flat	.030	0.76	30°	.187	4.75	N/A	N/A
19126M	.180	4.57	.810	20.57	Flat	.030	0.76	30°	.187	4.75	N/A	N/A
19226M	.212	5.38	1.100	27.94	Flat	.032	0.81	30°	.187	4.75	N/A	N/A
19357M	.363	9.22	1.594	40.49	Flat	.038	0.97	30°	.250	6.35	N/A	N/A
19567M	.300	7.62	1.596	40.54	Flat	.048	1.22	30°	.250	6.35	N/A	N/A
19096H	.188	4.78	1.060	26.92	Flat	.030	0.76	30°	.187	4.75	N/A	N/A
19110H	.188	4.78	1.060	26.92	Flat	.030	0.76	30°	.187	4.75	N/A	N/A
19126H	.156	3.96	1.524	38.71	Flat	.030	0.76	30°	.250	6.35	N/A	N/A
19226H	.210	5.33	1.504	38.20	Flat	.030	0.76	30°	.250	6.35	N/A	N/A

Note 1: Soft seat (DA) valves for liquid service from 5 - 100 psig (0.34 - 6.89 barg) require a special base for 19000L Series. Refer to Dimension "M" instead of Dimension "F" in this case.

# XIII. Maintenance (Contd.)

## A4. Machining the Disc Seat

1. When the disc seat cannot be repaired by lapping, it can be machined as shown in Figure 12, using the dimensions provided in Table 7.
2. GE recommends that the following procedure be adhered to when machining the disc seat:
  - a. Grip the disc in a collet.
  - b. True up the disc so that surfaces marked X and Y run true within .001" (0.03 mm) on an indicator.
  - c. Take light cuts across the seating surface until the damage is removed. Dimensions "R" and "Q", (and 15° angle when applicable) must be maintained.

- d. The disc is now ready for lapping. (See Table 6 for proper seat width).
- e. When the minimum thickness dimension "S" is reached, the disc should be replaced.

## B. O-Ring Seat Seal Valves (DA)

1. Replacing the O-Ring Retainer (3)

If slight damage is present, the O-Ring Retainer can be refurbished by either lapping or machining. O-Ring Retainer should be replaced if severely damaged or if dimension S (minimum) is exceeded (see Figure 12 and Table 7).

Table 6: Disc Seat Lapping Width (-2 Metal Seat Design)							
Set Pressure		Disc Width					
		19096, 19110, 19126		19226, 19357, 19567			
psig	bar	in.	mm	in.	mm	in.	mm
5 to 800	-0.34 to -55.16	Flat	Flat	0.02	-0.51		
801	Above -55.23	Flat	Flat	Note 1	Note 1		

Note 1: Add .005" (0.125 mm) per 100 psig (6.896 bar), until disc seat width has reached the maximum available width.

**ATTENTION!**

The O-Ring always should be replaced to ensure seat tightness.

2. Polishing the Base Seat

Normally the base seating area on this type of valve is not damaged, since the O-Ring absorbs the impact when foreign material is trapped between the O-Ring and the base seating area. The O-Ring will therefore hold a bubble tight seal with slight indications on the base seating surface. Nevertheless, slight indications on the base seat surface may be removed by lapping the base.

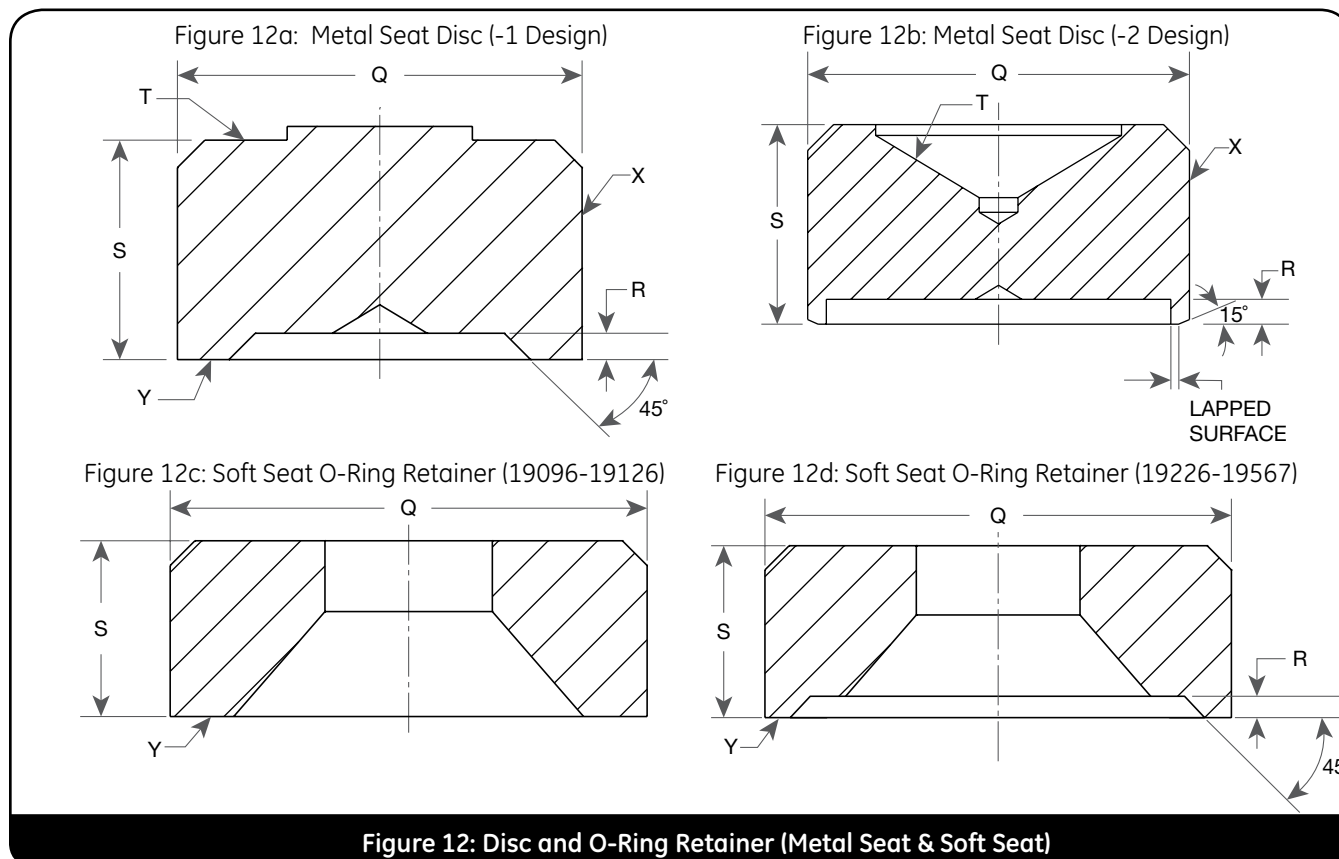

**Figure 12: Disc and O-Ring Retainer (Metal Seat & Soft Seat)**

# XIII. Maintenance (Contd.)

**Table 7: Rework Dimensions of the Disc Seat**

Valve Type	Disc (Metal Seat)								O-Ring Retainer (Soft Seat)					
	Q		R min.		S min.				Q		R min.		S min.	
					(-1 Design)		(-2 Design)							
	in.	mm	in.	mm	in.	mm	in.	mm	in.	mm	in.	mm	in.	mm
19096L,M	.461	11.71	.025	0.64	.243	6.17	.234	5.94	.426	10.82	N/A	N/A	.151	3.84
19096H	.461	11.71	.025	0.64	.243	6.17	.491	12.47	.426	10.82	N/A	N/A	.151	3.84
19110L,M	.461	11.71	.025	0.64	N/A	N/A	.234	5.94	.426	10.82	N/A	N/A	.151	3.84
19110H	.461	11.71	.025	0.64	N/A	N/A	.491	12.47	.426	10.82	N/A	N/A	.151	3.84
19126L,M	.527	13.39	.025	0.64	.243	6.17	.241	6.12	.489	12.42	N/A	N/A	.151	3.84
19126H	.527	13.39	.025	0.64	.243	6.17	.491	12.47	.489	12.42	N/A	N/A	.151	3.84
19226L <sup>1</sup> ,M <sup>1</sup>	.705	17.91	.025	0.64	.305	7.75	.272	6.91	.676	17.17	.025	0.64	.199	5.05
19226H <sup>1</sup>	.705	17.91	.025	0.64	.305	7.75	.546	13.87	.676	17.17	.025	0.64	.199	5.05
19357L <sup>1</sup> ,M <sup>1</sup>	.885	22.48	.025	0.64	.493	12.52	.454	11.53	.852	21.64	.025	0.64	.244	6.20
19567L <sup>1</sup> ,M <sup>1</sup>	1.113	28.27	.025	0.64	.493	12.52	.473	12.01	1.058	26.87	.025	0.64	.244	6.20

Note 1: These valves have a 15° angle as shown in Figure 12 (-2 Metal Seat Design).

## C. Checking Spindle Concentricity

### 1. General Information

It is important that the spindle (9) of a safety relief valve be straight in order to transmit the spring load to the disc without lateral binding. Over-gagging is one of the common causes of bent spindles. To check the essential working surfaces of the spindle, the method stated in the next section is recommended.

### 2. V-Block Support Set Up

a. The ball-pointed spindles should be placed in a piece of material, "B" that has been recessed to permit free rotation of the spindle (see Figure 13).

- b. Support the spindle with a V-block "A" placed near the upper end of the spindle, but below the threads.
- c. Apply a machinist's indicator at approximately 45° to the outer edge of the spring washer seat at "C". Rotate the spindle. The total indicator reading should not exceed .005" (0.13 mm). Straighten the spindle, if necessary.

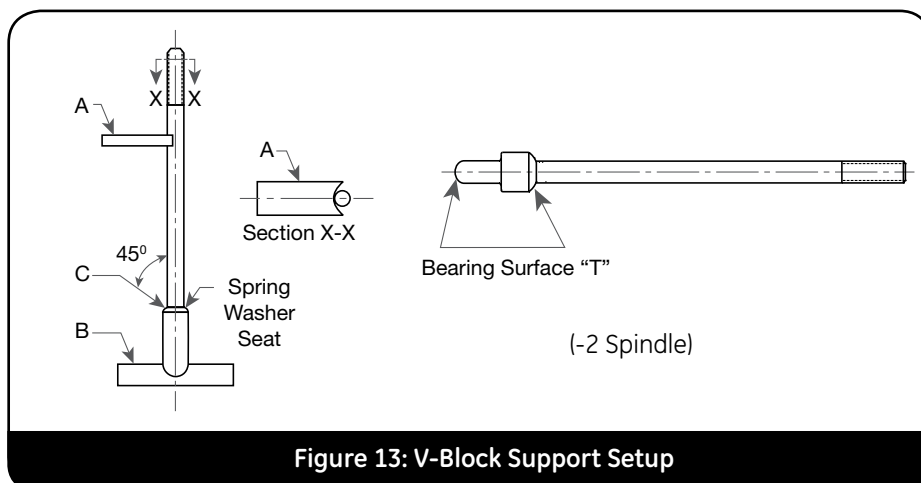

**Figure 13: V-Block Support Setup**

# XIV. Inspection and Part Replacement

## A. Base (1)

The base should be replaced if:

1. Seat Surface
  - a. Metal Seated-Seat surface "N" (see Figure 11), is scratched, nicked, corroded, leaks or is too wide and cannot be machined (see Table 2 and Section XIII. A3.2.b).
  - b. O-Ring Seat surface "N" (see insert, Figure 11), is scratched, nicked, corroded or leaks.
2. Threads (all) are torn, stripped or galled.
3. Guide seating surface "U" is scratched, nicked, corroded or dimension "L" is less than "L" minimum (see Figure 11, Tables 3 to 5, and Section XIII. A3.2.b).
4. Seat step "F" is at or above minimum listed in Table 5. "F" can be reestablished by machining as long as "L" stays within tolerance (see Section XIII. A3.2.b).

## B. Metal Seat Disc (2)

The metal seat disc should be replaced if:

1. Seat surface "Y" (see Figure 12), is damaged beyond lapping or machining limits.
2. Seat relief height "R" is less than "R" minimum and dimension "S" cannot be maintained (see Table 7).
3. Length "S" is less than "S" minimum (see Table 7).

## C. O-Ring Seat Seal Assembly

The O-Ring seat seal assembly parts should be replaced as follows:

1. O-Ring Seat Seal (37) – always replace.
2. O-Ring retainer (3)
  - a. Lapped seat relief height "R" is less than "R" minimum and dimension "S" cannot be maintained (see Figure 12 and Table 7).
  - b. Length "S" is less than "S" minimum (see Table 7).
  - c. Retainer Lockscrew - Always replace.

## D. Bonnet (6)

The bonnet should be replaced if:

1. Threads are stripped, torn or galled.
2. The guide seating surface is scratched, nicked, corroded or leaks.
3. Condition is porous, corroded or distorted.

## E. O-Ring Disc Holder (4)

The O-Ring disc holder should be replaced if:

1. The outside surface is worn, egged or galled and/or cannot meet "H" dimension (see Figure 14 and Table 8).
2. The spindle pocket bearing surface is galled or pitted.
3. The O-Ring groove is nicked, scratched or pitted.
4. The O-Ring retainer screw threads are torn, stripped or galled.

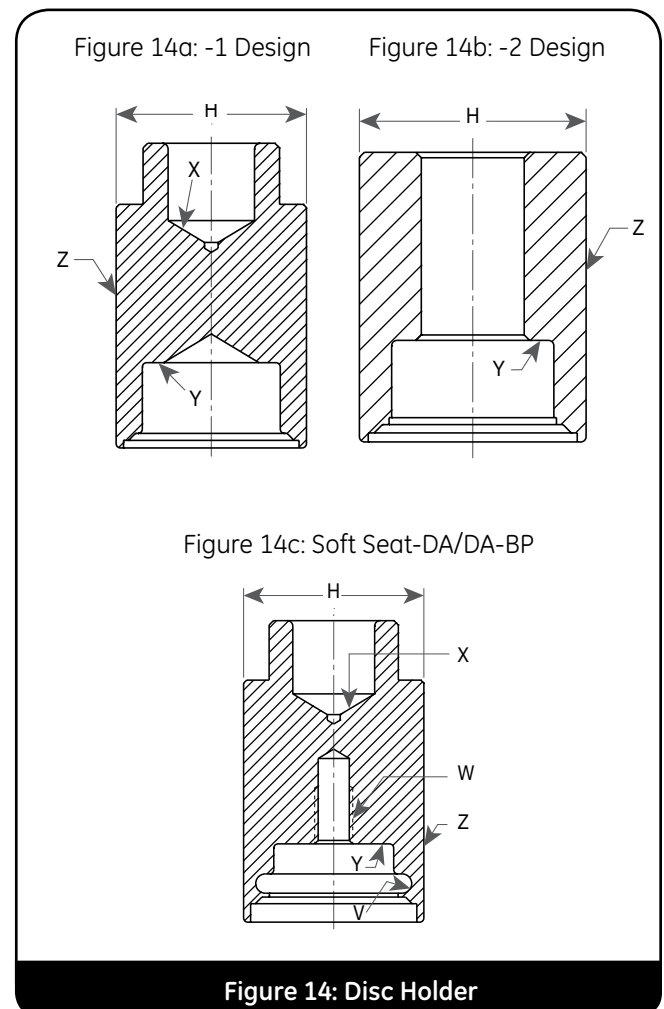

# XIV. Inspection and Part Replacement

**Table 8: Disc Holder Dimensions**

Valve Type	H DIA. ±.001" (±0.03 mm)		Valve Type	H DIA. ±.001" (±0.03 mm)	
	in.	mm		in.	mm
	19096L	.654		16.61	19126M
19110L	.654	16.61	19226M	1.000	25.40
19126L	.747	18.97	19357M	1.257	31.93
19226L	1.000	25.40	19567M	1.583	40.21
19357L	1.257	31.93	19096H	.654	16.61
19567L	1.583	40.21	19110H	.654	16.61
19096M	.654	16.61	19126H	.747	18.97
19110M	.654	16.61	19226H	1.000	25.40

- Hole dimension "K" is out of tolerance (see Figure 15 and Table 9).
- Guide Height Dimension "L" is out of tolerance (see Figure 15 and Table 9).
- "J" dimension is not within tolerance (see Figure 15 and Table 9).

## G. Spindle (9)

### G.1 MS - DA

Replace the spindle if:

- The bearing surfaces are galled, pitted or scratched
- Threads are torn, stripped or galled.
- The stem is bent (see Figure 13).

### G.2 DA - BP

The spindle should be replaced if:

- The bearing surfaces "V" are galled, pitted or scratched
- The threads are torn, stripped or galled
- The spindle is bent
- The O-Ring groove is nicked, scratched or pitted

## F. Guide (5)

Replace the guide if:

- The inside surface is worn, egged or galled.
- Base and bonnet seating surfaces are scratched, nicked, corroded or leaks.

Figure 15a: 19000L & M Valves

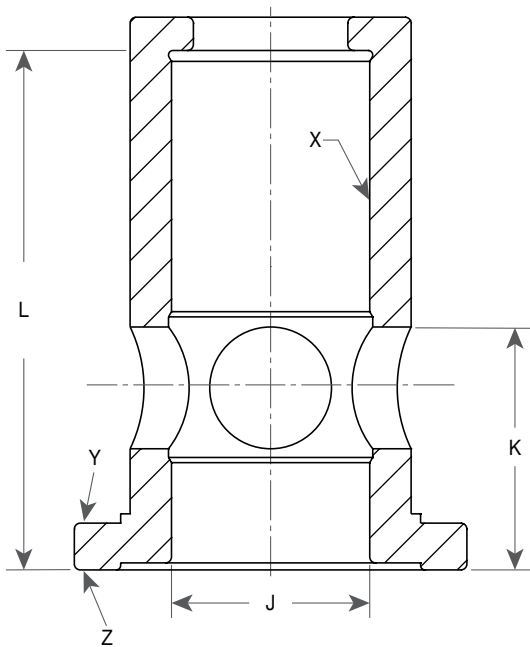

Figure 15b: 19000H Valves

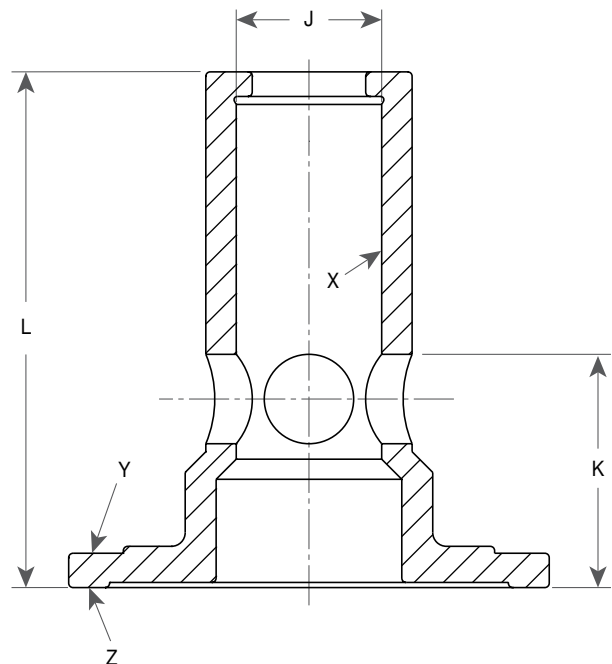

Figure 15: Guide

# XIV. Inspection and Part Replacement (Contd.)

**Table 9: Guide Dimensions**

Valve Type	J DIA ±.001" (±0.03 mm)		K				L min.			
			(Metal Seat - MS)		(Soft Seat-DA)		(Metal Seat - MS)		(Soft Seat-DA)	
	in.	mm	in.	mm	in.	mm	in.	mm	in.	mm
19096L	.661	16.79	.810 ± .007	20.57 ± 0.18	.810 ± .007	20.57 ± 0.18	1.701	43.21	1.701	43.21
19110L	.661	16.79	.810 ± .007	20.57 ± 0.18	.810 ± .007	20.57 ± 0.18	1.701	43.21	1.701	43.21
19126L	.754	19.15	.804 ± .007	20.42 ± 0.18	.804 ± .007	20.42 ± 0.18	1.717	43.61	1.717	43.61
19226L	1.007	25.58	1.109 ± .009	28.17 ± 0.23	1.109 ± .009	28.17 ± 0.23	2.267	57.58	2.267	57.58
19357L	1.264	32.11	1.623 ± .012	41.22 ± 0.30	1.623 ± .012	41.22 ± 0.30	3.105	78.87	3.105	78.87
19567L	1.590	40.39	1.671 ± .012	42.44 ± 0.30	1.671 ± .012	42.44 ± 0.30	3.159	80.24	3.159	80.24
19096M	.661	16.79	.810 ± .007	20.57 ± 0.18	.810 ± .007	20.57 ± 0.18	1.727	43.87	1.727	43.87
19110M	.661	16.79	.810 ± .007	20.57 ± 0.18	.810 ± .007	20.57 ± 0.18	1.727	43.87	1.727	43.87
19126M	.754	19.15	.804 ± .007	20.42 ± 0.18	.804 ± .007	20.42 ± 0.18	1.743	44.27	1.743	44.27
19226M	1.007	25.58	1.109 ± .009	28.17 ± 0.23	1.109 ± .009	28.17 ± 0.23	2.267	57.58	2.292	58.22
19357M	1.264	32.11	1.623 ± .012	41.22 ± 0.30	1.623 ± .012	41.22 ± 0.30	3.105	78.87	3.196	81.18
19567M	1.590	40.39	1.671 ± .012	42.44 ± 0.30	1.627 ± .012	41.33 ± 0.30	3.159	80.24	3.251	82.58
19096H	.661	16.79	1.060 ± .007	26.92 ± 0.18	1.060 ± .007	26.92 ± 0.18	2.227	56.57	2.227	56.57
19110H	.661	16.79	1.060 ± .007	26.92 ± 0.18	1.060 ± .007	26.92 ± 0.18	2.227	56.57	2.227	56.57
19126H	.754	19.15	1.523 ± .007	38.68 ± 0.18	1.523 ± .007	38.68 ± 0.18	2.707	68.76	2.707	68.76
19226H	1.007	25.58	1.515 ± .009	38.48 ± 0.23	1.515 ± .009	38.48 ± 0.23	3.027	76.89	3.027	76.89

## H. Spring (11)

Replace the spring if:

1. The ends are not ground flat and parallel.
2. The coils are bent, pitted or unevenly spaced.
3. The spring cannot be properly identified (spring chart).

### ATTENTION!

19000 Series valve springs do not have sufficient wire diameter to allow permanent spring marking.

The Set Pressure of the 19000 valve should be within the spring range of the valve spring. However if there is Constant Superimposed Backpressure, the Cold Differential Test Pressure should be within the Spring range of the Valve Spring. If the Cold Differential Test pressure is only established because of elevated temperature, then the Set Pressure should be within the spring range of the valve spring and the valves should be set at the Cold Differential Test Pressure.

## I. Spring Washers (10)

Replace the Spring Washers if:

1. The bearing surface is galled, pitted or scratched.
2. Corrosion affects the centering of the spring.

## J. Adjusting Screw (12)

Replace adjusting screw if:

1. Threads are torn, stripped or galled.
2. The bearing surfaces are galled, pitted or scratched.
3. The adjustment flats are damaged or rounded.

## K. Bonnet Top (7)

The bonnet top should be replaced if:

1. The threads are stripped, torn or galled.

## XIV. Inspection and Part Replacement (Contd.)

### L. Bonnet Bottom (8)

The bottom bonnet should be replaced if:

1. Threads are stripped, torn or galled
2. The guide seating surface is scratched, nicked, corroded or leaks
3. The backup plate seating surface is scratched, nicked or corroded.
4. Condition is porous, corroded or distorted

### M. Backup Plate (39)

The backup plate should be replaced if:

1. Inside circumference "X" is scratched, nicked, pitted or galled
2. O-Ring groove "W" is scratched, nicked, pitted or galled
3. Backup plate is distorted

### N. Spindle O-Ring (310XX011) (38)

The spindle O-Ring should always be replaced. The material and durometer of the spindle O-Ring should be the same material and durometer as that specified for the Seat O-Ring (37).

### O. Backup Plate O-Ring (310XX030) (40)

The backup plate O-Ring should always be replaced. The material and durometer of the backup plate O-Ring should be the same material and durometer as that specified for the seat O-Ring (37).

### P. Seat O-Ring (310XX013) (37)

The seat O-Ring should always be replaced. The material and durometer of the seat O-Ring should be the same material and durometer as that specified on the O-Ring nameplate.

## XV. Reassembly of 19000 Series SRV

### A. Metal Seat Valves (MS)

(See Figures 1 and 2)

1. Bearing surfaces should be ground together using a 320 grit lapping compound (see Table 17). These surfaces are:
  - a. The disc holder-spindle pocket and spindle spherical nose radius,
  - b. The lower spring washer and spindle spring washer radius and
  - c. The upper spring washer and adjusting screw spherical radius. Clean all parts before assembly.
2. Apply small amount of non-copper based thread lubricant to the guide-bonnet seating surface and the bonnet and base threads.
3. Use a clean base (1) lapped for the valve set pressure (see seat width requirement Table 5). Place a lapped disc (2) on the base with lapped surfaces facing each other. Place the disc holder (4) onto the disc and base. Place guide (5) over disc holder onto base. Lubricate the disc holder-spindle bearing surface with non-copper based thread lubricant
4. Lubricate the spindle nose with a small amount of non-copper based thread lubricant and insert the spindle (9) into the disc holder spindle pocket.
5. Apply a small amount of non-copper based thread lubricant on the bearing surface of the lower spring washer (10) and slip it over the spindle (9). Install the spring (11) and upper spring washer.
6. Apply a small amount of non-copper based thread lubricant to the bonnet-base threads and guide seating surface. When a stainless steel bonnet (6) and base (1) are used, and/or a standard bonnet for service above 500° temperature, apply non-copper based thread lubricant to the bonnet-base threads and guide (5) seating surface. Before tightening the bonnet completely, adjust the position of the guide so that one of the holes is lined up with the discharge of the valve. Tighten the bonnet using sufficient torque from Base Torque Specification (see Table 10).
7. Thread the adjusting screw locknut (13) on the adjusting screw (12). Apply a light coat of non-copper based thread lubricant to the adjusting screw threads and spherical radius. Thread the adjusting screw locknut (13) onto the adjusting screw (12). Apply a small amount of non-copper based thread lubricant to the tip of the adjusting screw. Install the adjusting screw in the bonnet, rotating the number of times required to compress the spring slightly.



## XV. Reassembly of 19000 Series SRV (Contd.)

**Table 10: Base Torque Specifications**

VALVE TYPE	Recommended Torque		Maximum Torque	
	ft-lb	Nm	ft-lb	Nm
19096L	125	169	250	339
19110L	125	169	250	339
19126L	125	169	250	339
19226L	200	271	400	542
19357L	625	847	1000	1356
19567L	625	847	1000	1356
19096M	175	237	300	407
19096M-BP	175	237	300	407
19110M	175	237	300	407
19126M	175	237	300	407
19226M	500	678	750	1017
19357M	650	881	1200	1627
19567M	650	881	1200	1627
19096H	500	678	750	1017
19110H	500	678	750	1017
19126H	1000	1356	1500	2034
19226H	1000	1356	1500	2034

Use pliers to hold the spindle (9) in position and prevent galling. Adjust the adjusting screw to the measurement recorded during disassembly. (See Metal Seat Valves disassembly instructions, point (b) on page 16.)

- The valve is now ready for setting. After the set pressure has been adjusted, tighten the adjusting screw locknut (13). Install the cap (18) and cap gasket (17), or lifting gear, on the valve after applying a small amount of non-copper based thread lubricant to the gasket seal surfaces, as well as to the cap and bonnet threads.

### B. O-Ring Seat Seal Valves (DA)

(See Figure 2)

- All bases shall be lapped flat enough to remove nicks and burrs.
- Bearing surfaces should be ground together using a 320 grit lapping compound (see Table 17), clean all parts before assembly. These surfaces are:
  - The disc holder-spindle pocket and spindle spherical nose radius.
  - The lower spring washer and spindle spring washer radius.
  - The upper spring washer and adjusting screw spherical radius.
- Carefully insert a new O-Ring seat seal (37) into the disc

holder (4). Make sure the O-Ring is the right size, material and hardness for the application. Refer to the valve nameplate for information required when ordering an O-Ring seat seal.

- Install the O-Ring retainer (3) and a new retainer lockscrew (36).
- Place the disc holder assembly onto the base (1) and place the guide (5) onto base. The guide seating surfaces should be free of any nicks or scratches.
- Lubricate the spindle nose with a small amount of non-copper based thread lubricant and insert the spindle (9) into the disc holder spindle pocket.
- Apply a small amount of non-copper based thread lubricant on the bearing surface of the lower spring washer (10) and slip it over the spindle (9). Install the spring (11) and upper spring washer (10).
- The guide bonnet seating surfaces should be free of any nicks or scratches, with a 63 RMS finish (maximum). Apply non-copper based thread lubricant to the bonnet and base threads and guide seating surfaces. Install the bonnet (6) on the base (1) using torque from Base Torque Specifications (see Table 10). Before tightening the bonnet completely, adjust the position of the guide (5) so that one of the holes in the guide is in line with the discharge of the valve. Tighten the bonnet using sufficient torque from Base Torque Specification (see Table 10).
- Thread the adjusting screw locknut (13) onto the adjusting screw (12). Apply a small amount of non-copper based thread lubricant to the tip of the adjusting screw. Install the adjusting screw in the bonnet, rotating the number of times required to compress the spring slightly. Use pliers to hold the spindle (9) in position and prevent galling. Adjust the adjusting screw to the measurement recorded during disassembly. (See O-Ring Seat Seal Valves (DA) disassembly instructions, point (b) on page 20.)
- The valve is now ready for setting. After the valve set pressure has been adjusted, tighten the adjusting screw locknut (13). Install the cap gasket (17) and cap (18), or lifting gear, on the valve after applying a small amount of non-copper based thread lubricant to the gasket seal surfaces, as well as to the cap and bonnet threads.

### C. 19096M-DA-BP O-Ring Seat Seal Valves (See Figure 6)

- All base seats shall be lapped flat enough to remove nicks and burrs.

## XV. Reassembly of 19000 Series SRV (Contd.)

2. Bearing surfaces should be ground together using a 320 grit lapping compound (see Table 17), clean all parts before assembly. These surfaces are the following:
  - a. The disc holder-spindle pocket and the spindle spherical holder-spindle radius (for O-ring valves or -1 metal seat design);
  - b. The lower spring washer and spindle spring washer radius.
  - c. The upper spring washer and adjusting screw spherical radius.
3. Carefully insert a new seat O-Ring seal (37) into the disc holder (4). Make sure the seat O-Ring is the right size, material and hardness for the application. Refer to the valve nameplate for information required when ordering an O-Ring.
4. Install the O-Ring retainer (3) and the retainer lockscrew (36). Apply thread locker fluid to lock the screw in position.
5. Place the disc holder assembly onto the base (1) and place the guide (5) onto the base. The guide seating surfaces should be free of any nicks or scratches.
6. The guide to bonnet bottom seating and the backup plate ring to bonnet bottom seating surfaces should be free of any nicks or scratches. The guide to bottom bonnet (8) seating surface should have a finish with a maximum of 63 RMS. Apply non-copper based thread lubricant or equivalent anti-seize to the bonnet bottom threads on the base and guide seating surfaces. Install the bonnet on the base (1). Tighten the bonnet bottom to the base using sufficient torque from Base Torque Specification (see Table 10).
7. Place backup plate O-Ring 310XX030 (40) in the O-Ring groove in the backup plate (39) using a small amount of O-Ring lubricant. Verify that the backup plate seating surface on the bonnet bottom and the backup plate ring inside diameter have no more than a 32 RMS finish. Ensure that they are clean and free from nicks and scratches. Place the backup plate (39), O-Ring side down, into the counterbore in the bonnet bottom.
8. Place spindle O-Ring 312XX011 (38) into the O-Ring groove on the spindle (9). Lubricate the spindle nose with a small amount of non-copper based thread lubricant and insert the spindle through the backup plate into the disc holder-spindle pocket.
9. Apply a small amount of non-copper based thread lubricant to the bearing surface of the lower spring washer (10) and slip it over the spindle (9). Install the spring (11) and upper spring washer (10).
10. Apply non-copper-based thread lubricant to the bonnet top threads for the bonnet bottom and cap joints. Install the bonnet top (7) into the bonnet bottom (8) carefully, allowing the spindle (9) to line up with the hole in top. Torque bonnet top to bonnet bottom with 133 ft/lb (180.32 Nm) recommended torque [maximum torque not to exceed 500 ft/lb (677.91 Nm)].
11. Thread the adjusting screw locknut (13) on the adjusting screw (12). Apply a small amount of non-copper based thread lubricant to the tip of the adjusting screw. Install the adjusting screw in the bonnet top, rotating the number of times required to compress the spring slightly. Use pliers to hold the spindle in position and prevent galling.  
  
Adjust the adjusting screw to the measurement recorded during disassembly (see step (b), "Disassembly").
12. The valve is now ready for setting.

### ATTENTION!

The top bonnet is vented and the top bonnet vent must not be plugged.

# XVI. Setting and Testing

**⚠ DANGER**

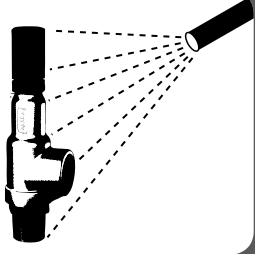

Decontaminate or clean, if necessary, before pre-testing or disassembly. Safety and environmental precautions must be taken for the decontamination or cleaning method used

**⚠ DANGER**

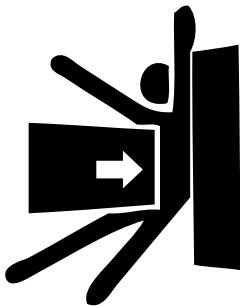

Do not stand or place hand in front of valve discharge flange if valve is under pressure.

## A. General Information

Before putting the reconditioned valve in service, it must be set to open at the required set pressure as shown on the nameplate. Although the valve can be set on the service installation, it is more convenient to set the valve and check seat tightness on a test stand. Any spring replacement shall be in accordance with current guidelines.

## B. Test Equipment

The test stand used for testing SRVs normally consists of a pressure source supply line with a throttle valve and receiver that have the following features:

1. Outlet for attaching the valve to be tested;
2. Pressure gauge with a shut-off valve;
3. Drain line with a shut-off valve; and
4. Adequate receiver volume for the valve to be tested and to achieve proper operation.

## C. Test Media

For best results, valves shall be tested by type as follows:

1. Steam valves are tested on saturated steam;
2. Air or gas valves are tested on air or gas at ambient temperature; and
3. Liquid valves are tested on water at ambient temperature.

## D. Setting the Valve

Set the valve to open at the set pressure as shown on the nameplate. If a cold differential test pressure is indicated on the nameplate, set the valve to open at that pressure on the test stand. (The cold differential test pressure is the set pressure corrected to compensate for backpressure and/or operating temperature.) A new cold differential test pressure may need to be determined if changes are to be made to the set pressure or backpressure or if the service temperature changes.

Note: This design will allow the set pressure to remain constant under superimposed variable back pressure conditions. If changes are to be made to the set pressure or back pressure or the service temperature changes, a new cold differential test pressure may need to be determined.

## E. Set Pressure Compensation

### Cold Differential Test Pressure for Temperature Compensation

During production testing, the SRV is often tested at temperatures that are different from the temperatures the SRV will be exposed to in service. Increasing the temperature from ambient temperature causes the set pressure to decrease. The decrease in set pressure is due to thermal expansion of the seating area and spring relaxation. Therefore, it is important to compensate for the difference between production test temperature and service temperature. The service temperature

is the normal operating temperature of the SRV. If the operating temperature is unavailable, do not correct the SRV set pressure.

Table 11 lists the set pressure multipliers to be used when computing the cold differential test (CDTP) pressure for valves being set on an air or water test stand at ambient temperatures.

Valves to be used in saturated steam service are tested on saturated steam. Therefore, no CDTP is required. However, valves in superheated steam service are tested on saturated steam and require a CDTP.

Table 12 lists the multiplier to be used based on temperature above the saturated temperature (degrees of superheat).

# XVI. Setting and Testing (Contd.)

**Table 11: Set Pressure Multipliers for Cold Differential Test Pressure at Ambient Temperature**

Operating Temp.		Multiplier	Operating Temp.		Multiplier
°F	°C		°F	°C	
250	121	1.003	900	482	1.044
300	149	1.006	950	510	1.047
350	177	1.009	1000	538	1.050
400	204	1.013	1050	566	1.053
450	232	1.016	1100	593	1.056
500	260	1.019	1150	621	1.059
550	288	1.022	1200	649	1.063
600	316	1.025	1250	677	1.066
650	343	1.028	1300	704	1.069
700	371	1.031	1350	732	1.072
750	399	1.034	1400	760	1.075
800	427	1.038	1450	788	1.078
850	454	1.041	1500	816	1.081

**Table 12: Set Pressure Multipliers for Cold Differential Test Pressure**

Degrees of Superheat Temperature		Multiplier
°F	°C	
100	38	1.006
200	93	1.013
300	149	1.019
400	204	1.025
500	260	1.031
600	316	1.038
700	371	1.044
800	427	1.050

## Cold Differential Test Pressure For Back Pressure Compensation

When a conventional Series 19000 valve is to operate with a constant back pressure, the cold differential test pressure is the set pressure minus the constant back pressure.

### Sample Calculations For Series 19000 safety relief valves (refer to Tables 11 and 12)

#### Set pressure 2500 psig (172.37 barg), temperature 500 ° F (260.0 °C), backpressure atmospheric

Set Pressure .....2500 psig (172.37 barg)  
 Multiplier (see Table 11).....X1.019  
 Cold Differential Set Pressure .....2548 psig (175.68 barg)

#### Set pressure 2500 psig(172.37 barg), temperature 500° F(260° C), constant backpressure 150 psig(10.34 barg).

Set Pressure ..... 2500 psig (172.37 barg)  
 Minus Constant Back Pressure .....-150 psig(-10.34 barg)

Differential Pressure.....2350 psig (165.13 barg)  
 Multiplier (see Table 11).....X1.019  
 Cold Differential Set Pressure.....2395 psig(165.13 barg)

#### Set pressure 2500 psig (172.37), temperature 100° F (37.8° C), constant backpressure 150 psig (10.34 barg).

Set Pressure .....2500 psig (172.37 barg)  
 Minus Constant Back Pressure .....-150 psig (-10.34 barg)  
 Cold Differential Set Pressure .....2350 psig (162.03 barg)

#### Set pressure 400 psig (27.58 barg) on superheated steam, temperature 650° F (343.3 °C), backpressure atmospheric

Operating Temperature..... 650° F (343.3 °C)  
 Minus Temperature of Saturated Steam at 400 psig (27.58 barg) ..... -448° F(-266.7° C)  
 Degrees of Superheat ..... 202° F(94.4° C)  
 Set Pressure ..... 400 psig (27.58 barg)  
 Multiplier (see Table 12).....X1.013  
 Cold Differential Set Pressure ..... 405 psig (27.92 barg)

## F. Blowdown

The blowdown for all series 19000 valves is fixed. Do not attempt to adjust the blowdown on these valves. Typical blowdown is less than 10 percent. The blowdown under the back pressure conditions will cause a shorter blowdown than when observed with no back pressure.

# XVI. Setting and Testing (Contd.)

## G. Simmer

If simmer causes erratic valve opening, refer to the Trouble Shooting Guide in this manual.

## H. Seat Leakage

### 1. Air

The air-leakage test shall be performed with all connections and openings in the body and bonnet pressure-tight. The cap, with the gasket which covers the adjusting screw, must be installed. Test the valve for leakage using an API test fixture. The API leakage test procedure is described below:

- a. Per API Standard 527 (ANSI B147.1-72), a standard test fixture consists of a piece of tubing of .313" (7.94 mm) x .035" (0.89 mm) wall, one end of which is joined to an adapter on the valve outlet and the other end of which is immersed .05" (12.7 mm) below the surface of a reservoir of water.
- b. The leakage rate for a valve with metal to metal seats shall be determined with the valve mounted vertically and using a standard test fixture, as described above. The leakage rate, in bubbles per minutes, shall be determined with the pressure at the safety relief valve inlet held at 90 percent of the set pressure, immediately after popping, for valves set 51 psig (3.52 barg) and above. On valves set at 50 psig (3.45 barg) and below, test for leakage at 5 psig (0.34 barg) below the set pressure, immediately after popping. The test pressure shall be applied for a maximum of one minute.
- c. The Tightness Standard is the leakage rate in bubbles per minute and shall not exceed that shown in Table 13 for metal seat valves or Table 14 for O-Ring seat seal valves. A valve with a seat of resilient material (i.e., an O-Ring valve) shall show no leakage at pressures less than those indicated in Table 13 when the test medium is either air or water.

Table 13: Metal Seat Valve Leakage Rate	
Max Leakage Rate	Approximate Leakage Rate
(Bubbles per minute)	ft <sup>3</sup> per 24 hr. (Liters per 24 hr.)
40	0.06 (16.99)

Table 14: O-Ring Seat Valve Leakage Rate		
Set Pressure		Min. Leak Point (% of Set Pressure)
psig	barg	
15 to 30	1.03 to 2.07	90%
31 to 50	2.14 to 3.45	92%
51 to 100	3.52 to 6.89	94%
101 or greater	6.96 or greater	97%

### 2. Water

When a metal-to-metal seat valve is tested using water as the test medium, there shall be no leakage, as determined by sight when the pressure is held at 90 percent of set pressure.

For O-Ring seat seal valves use Table 13 to determine the percentage of set pressure.

### c. Steam

When a metal-to-metal seat valve is checked for tightness using steam as the test medium (at 90 percent of the set pressure), there shall be no visual or audible leakage after the interior of the valve is allowed to dry after popping. If there is no visual or audible leakage, the valve is acceptable.

For O-Ring seat seal valves use Table 14 to determine the percentage of set pressure."

### I. Back Pressure Testing

#### I.1 (MS & DA)

After the valve has been set for the correct opening pressure, it must be back pressure tested. Testing can be conducted by installing the cap (with gasket) and applying air or nitrogen to the valve outlet. Test pressure should be 30 psig (2.07 barg) or the actual valve back pressure, whichever is greater. Examine the base (1) to bonnet (6) joint for leakage during back pressure testing:

Note: Leakage is best detected by application of a liquid leak detector. The use of soap or household detergent as a leak detector is not recommended, as it may cover up leaks.

Repair of leaking valve joints may be attempted by tightening the leaking joint while the valve is still on the stand. If this does not stop the leak, disassemble and inspect the leaking joint. The seating surfaces should be better than a 32 RMS finish.

## XVI. Setting and Testing (Contd.)

The valve must be re-tested if disassembly is required. After the valve set pressure has been adjusted, tighten the adjusting screw locknut (13). Install the cap gasket (17) and cap (18) or lifting gear on the valve after applying a small amount of non-copper based thread lubricant to the gasket seal surfaces, and the cap and bonnet threads pressure.

### I.2 (19096M-DA-BP)

After the valve has been set for the correct opening pressure, it must be back pressure tested. Testing can be conducted by installing the cap (with gasket) and applying air or nitrogen to the valve outlet. Test pressure should be 30 psig (2 barg) or the actual valve back pressure, whichever is greater. Examine the following components for leakage during back pressure testing:

- base (1) to bonnet bottom (8) joint,
- bonnet bottom (8) to bonnet top (7) joint, and
- the bonnet top vent port.

Note: Leakage is best detected by application of a liquid leak detector. The use of soap or household detergent as a leak detector is not recommended, as it may cover up leaks.

Repair of leaking valve joints may be attempted by tightening the leaking joint while the valve is still on the stand. If this does not stop the leak, disassemble and inspect the leaking joint. If

the leak is at the loose bonnet top vent plug, the valve should be disassembled and the backup plate O-Ring and spindle O-Ring must be inspected. The seating surfaces for these O-Rings must also be inspected for nicks, damage or dirt. The seating surfaces should be better than a 32 RMS finish. The valve must be re-tested if disassembly is required. After the valve set pressure has been adjusted, tighten the adjusting screw locknut (13). Install the cap gasket (17) and cap (18) or lifting gear on the valve after applying a small amount of non-copper based thread lubricant to the gasket seal surfaces and the cap and bonnet top threads.

#### ATTENTION!

Be careful when removing O-Rings to avoid damage to the O-Ring groove.

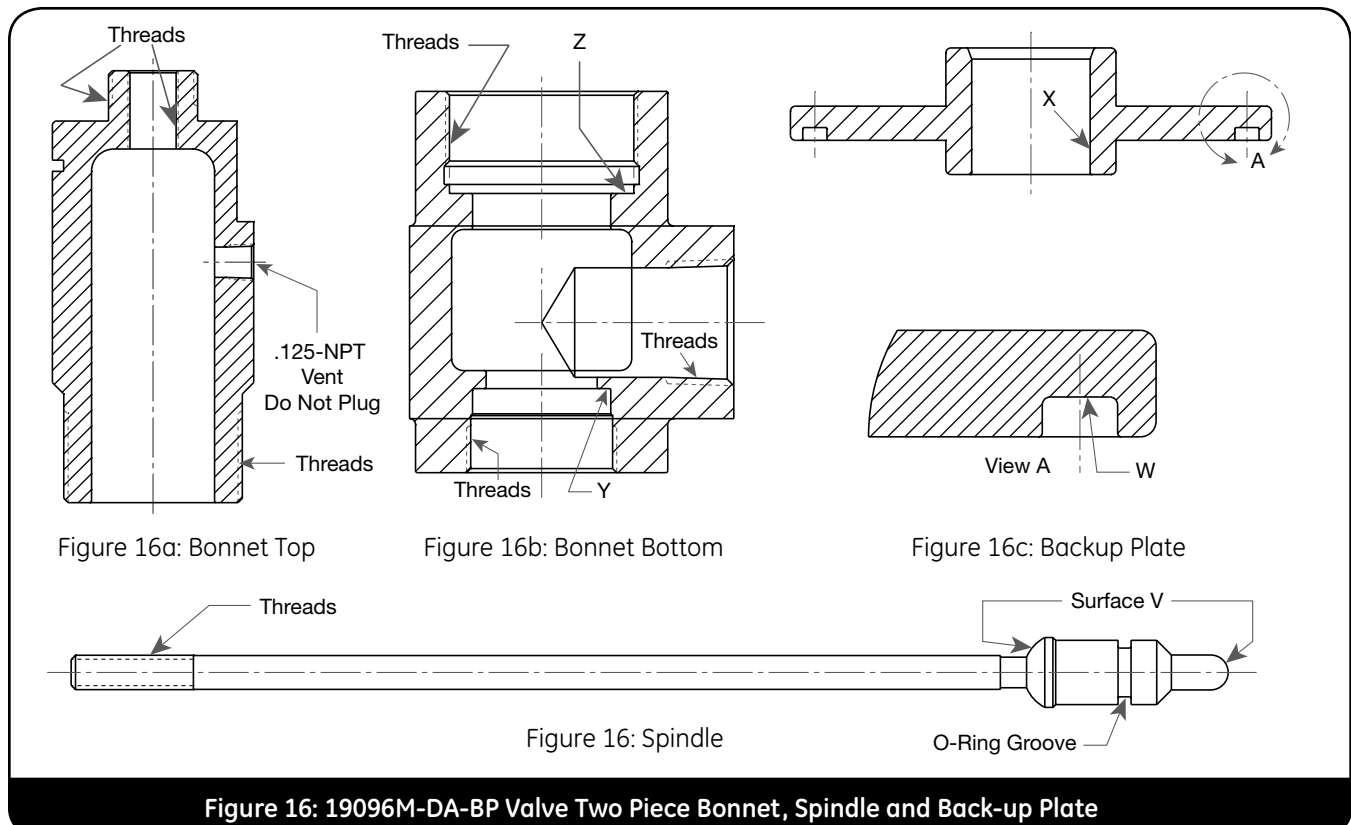

Figure 16: 19096M-DA-BP Valve Two Piece Bonnet, Spindle and Back-up Plate

# XVI. Setting and Testing (Contd.)

## J. Hydrostatic Testing and Gaging

When hydrostatic tests are required after installation of an SRV, remove the SRV and replace it with a blind flange or pipe plug/cap. If the hydrostatic test pressure will not be greater than the operating pressure of the equipment, a test gag may be used. Very little force, i.e. finger-tight pressure, on the test gag is sufficient to hold hydrostatic pressures. Too much force applied to the gag may bend the spindle and damage the seat. After a hydrostatic test, the gag must be removed and replaced by the sealing plug furnished for this purpose (see Figure 17). (Test gags for Consolidated SRVs can be furnished for all types of caps and lifting gears.)

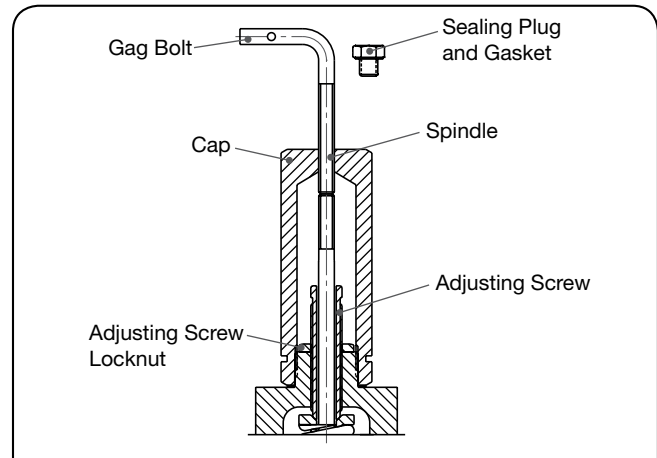

Figure 17: Typical Cap with Gag

## K. Manual Popping of the Valve

Consolidated safety relief valves are furnished, when so ordered, with packed or plain lifting levers for hand popping.

When the valve is to be opened by hand using the lifting lever, the pressure at the valve inlet should be at least 75 percent of the valve's set pressure. Under flowing conditions, the valve must be fully lifted from its seat, so that dirt, sediment and scale

will not become trapped on the seating surfaces. When allowing the valve to close under flowing conditions, completely release the lever from maximum lift to snap the valve back on its seat.

Since, in some cases, the dead weight of the lever may have a tendency to lift the valve disc, the lever should be hung, supported or counter weighted so the lifting fork does not contact the release nut.

# XVII. Trouble Shooting

Table 15: Trouble Shooting Guide

Problem	Probable Cause	Corrective Action
Valve leaking	<ul style="list-style-type: none"> <li>a. Damaged seat or O-Ring</li> <li>b. Bearing point damage</li> <li>c. Part misalignment</li> <li>d. Discharge stack binding on outlet</li> </ul>	<ul style="list-style-type: none"> <li>a. Disassemble valve, lap seating surfaces, replace disc or O-Ring (if required) as outlined in this manual</li> <li>b. Grind and polish</li> <li>c. Disassemble valve, inspect contact area of disc and base, lower spring washer or spindle, compression screw, spindle straightness, etc. as outlined in this manual</li> <li>d. Correct as required</li> </ul>
Simmer	<ul style="list-style-type: none"> <li>a. Line vibrations</li> <li>b. Lapped seat too wide</li> </ul>	<ul style="list-style-type: none"> <li>a. Investigate and correct cause</li> <li>b. Rework seat as specified in this manual</li> </ul>
Chatter	<ul style="list-style-type: none"> <li>a. Improper installation or valve sizing</li> <li>b. Built-up back pressure</li> </ul>	<ul style="list-style-type: none"> <li>a. Check for piping instructions; check required capacity</li> <li>b. Check outlet piping for flow restrictions</li> </ul>
No action; valve does not go into full lift; valve does not close from full lift.	<ul style="list-style-type: none"> <li>a. Foreign material trapped between disc holder and guide</li> </ul>	<ul style="list-style-type: none"> <li>a. Disassemble valve and correct any abnormality as outlined in this manual. Inspect system for cleanliness.</li> </ul>

## XVIII. Maintenance Tools and Supplies

The laps identified in Table 16, are required for proper maintenance of Consolidated Series 19000 seats.

Note: One set of three laps is recommended for each size to assure ample flat laps are available at all times.

- The Lap Resurfacing Plate is part number 0439003
- Lapping compounds are identified in Table 17.
- Laps and the lapping plate may be purchased from GE

Table 16: Laps	
Valve	Part Number
19096L, 19110L, 19126L, 19096M, 19110M, 19126M, 19096H, 19110H, 19126H	1672802
19226L, 19226M, 19226H	1672803
19357L, 19567L, 19357M, 19567M	1672805

Table 17: Lapping Compounds					
Brand	Grade	Grit	Lapping Function	Size Container	Part No.
Clover	1A	320	General	4 oz	199-3
Clover	3A	500	Finishing	4 oz	199-4
Kwik-Ak-Shun	----	1000	Polishing	1 lb 2 oz	199-11 199-12



# XIX. Replacement Parts Planning

## A. General Information

The importance of maintenance planning is the key to good plant operations. Part of that planning involves making sure that replacement parts needed to repair valves are available at the jobsite when required. Developing and implementing a standard valve maintenance plan will quickly pay for itself by eliminating costly downtime, unscheduled outages, etc.

## B. Inventory Planning

The basic objectives in formulating a replacement parts plan are:

1. Prompt availability,
2. Minimum downtime,
3. Sensible cost, and
4. Source control.

Having parts immediately available from plant storeroom inventory is obviously the best way to accomplish those objectives. Since it is impractical to have every part that might be needed to accomplish a given repair in stock at all times, guidelines for establishing meaningful inventory levels are summarized in Table 18.

In addition, you can contact your local Green Tag Center or GE authorized sales representative (contact information can be found at the end of this manual) for assistance in determining inventory levels, pricing and ordering parts.

## C. Replacement Parts List

Consult the Recommended Spare Parts list (see Tables 19 and 20) to determine the parts to include in the inventory plan.

Select the desired parts and determine those required for proper maintenance of the valve population in the plant.

## D. Identification and Ordering Essentials

When ordering service parts, please furnish the following information to ensure receiving the correct replacement parts:

- (1) Identify valve by the following nameplate data:
  - (a) Size .750 (19.05 mm)
  - (b) Type 19096LC - 1
  - (c) Temperature class (Spring Selection) S/N
  - (d) Serial Number TC75834
- (2) Specify parts required by:
  - (a) Part name
  - (b) Part number (if known)
  - (c) Quantity

**Table 18: Establishing Inventory Levels**

Part Classification	Replacement Frequency	Need Coverage Probability <sup>1</sup>
Class I	Most frequent	70 percent
Class II	Less frequent but critical	85 percent
Class III	Seldom replaced	95 percent
Class IV	Hardware	99 percent

Note 1: Need Coverage Probability means that percentage of time the user plant will have the right parts to make the proper repair on the product, (i.e. if Class I parts are stocked at the owner's facility, the parts needed to repair valve in question will be immediately available in 70 percent of all instances).

# XX. Genuine Consolidated Parts

Each time replacement parts are needed, keep these points in mind:

- GE designed the parts
- GE guarantees the parts
- GE's Consolidated valve products have been in service since 1879
- GE has worldwide service
- GE has fast response availability for parts with the global Green Tag Center / authorized sales representatives network

## XXI. Recommended Spare Parts

**Table 19: Metal to Metal Seat Valves**

Class	Part name	Quantity Parts/Size Type & Material Valves in Service	Need Coverage Probability
I	Disc	1/1	70 percent
	Gaskets, Cap	1/1	
II	Disc Holder	1/5	85 percent
	Spindle	1/5	
	Guide	1/5	
III	Spring Assembly	1/5 <sup>1</sup>	95 percent
	Compression Screw	1/5	
IV	Compression Screw Locknut	1/5	99 percent
	Cap (specify screwed, packed, or plain)	1/5	
	Release Nut (used on packed or plain lever only)	1/5	
	Release Locknut (used on packed or plain lever only)	1/5	

**Table 20: O-Ring Seat Valves**

Class	Part name	Quantity Parts/Size Type & Material Valves in Service	Need Coverage Probability
I	O-Ring Retainer	1/1	70 percent
	O-Ring	1/1	
	Lock Screw	1/1	
	Gaskets, Cap	1/1	
II	Disc Holder	1/5	85 percent
	Spindle	1/5	
	Guide	1/5	
III	Spring Assembly	1/5 <sup>1</sup>	95 percent
	Compression Screw	1/5	
IV	Compression Screw Locknut	1/5	99 percent
	Cap (specify screwed, packed, or plain)	1/5	
	Release Nut (used on packed or plain lever only)	1/5	
	Release Locknut (used on packed or plain lever only)	1/5	

Note 1: Consult Spring Selection Chart before ordering springs to determine actual quantities required in view of pressure setting potential in each spring range.

**YOUR SAFETY IS OUR BUSINESS!!!**

GE has not authorized any company or any individual to manufacture replacement parts for its valve products. When ordering replacement valve parts, please specify in your purchase order: "ALL PARTS MUST BE DOCUMENTED AS NEW AND SOURCED FROM GE OR YOUR LOCAL GREEN TAG CENTER / GE AUTHORIZED SALES REPRESENTATIVE."

# XXII. Field Service, Training and Repair Program

## A. Field Service

GE provides safe, reliable valve services through our Green Tag certified valve assemblers and repair centers. The first valve repair network of its kind and today's industry leader, our authorized Green Tag Centers have successfully served the valve market for more than 25 years. Our services include:

### Valve Survey:

- Comprehensive, accurate record of all PRVs.
- Interchangeability identified.
- Identify forgotten or overlooked valves.
- Product upgrades to reduce cost and improve performance.

### Inspection of the Valve & Installation

- Visual evaluation of the installation for compliance to codes and regulations
- Written evaluation covering compliance issues and discrepancies
- Recommendations and corrective actions

### Testing

- On-site and in-place testing using the GE's EVT testing device
- Total computer-based valve management system
- Free interchange of information
- Historical data and permanent record of traceability
- Maintenance scheduling and planning
- Repair intervals validated by each valves' maintenance history
- Code compliance
- Accessible via secure password-protected internet connection.
- Downloadable and printable reports.
- Base line history established.

### Repair

- GE Audited Facility
- Using GE's Inspection Criteria and Critical Dimensions
- By fully trained and certified pressure relief valve technicians
- Using original manufactured parts

### Inventory Control

- Global access to spare parts inventories via [www.greentag.net](http://www.greentag.net) with your local Green Tag Center / GE's authorized sales representative
- Parts interchangeability

- Obsolete and excess inventory identified
- Recommend cost effective inventories

### ValvKeep\*

- Total computer-based valve management system
- Free interchange of information
- Historical data and permanent record of traceability
- Maintenance scheduling and planning
- Repair intervals validated by each valves' maintenance history
- Code compliance
- Accessible via secure password-protected internet connection.
- Downloadable and printable reports

## B. Factory Repair Facilities

The factory at Alexandria, Louisiana, maintains a complete Consolidated products repair center. The Repair Department, in conjunction with the manufacturing facilities, is equipped to perform specialized repairs and product modifications, e.g., butt-welding, code welding and pilot replacement.

Contact: Valve Repair Department at +(1) (318) 640-6057.

## C. SRV Maintenance Training

The rising costs of maintenance and repair in the utility and process industries indicate the need for trained maintenance personnel. GE conducts service seminars that help your maintenance and engineering personnel reduce these costs. Seminars, conducted either at your site or ours, provide participants with an introduction to the basics of preventative maintenance necessary to minimize downtime, reduce unplanned repairs, and increase valve safety. While these seminars do not create "instant experts," they do provide the participants with hands-on experience with Consolidated valves. The seminar also includes valve terminology and nomenclature, component inspection, troubleshooting, setting, and testing with emphasis on the ASME Boiler and Pressure Vessel Code.

For further information, contact the Consolidated Product Training Manager by fax at (318) 640-6325 or telephone at (318) 640-6054.

# DIRECT SALES OFFICE LOCATIONS

AUSTRALIA  
Brisbane:  
Phone: +61-7-3001-4319  
Fax: +61-7-3001-4399

Perth:  
Phone: +61-8-6595-7018  
Fax: +61 8 6595-7299

Melbourne:  
Phone: +61-3-8807-6002  
Fax: +61-3-8807-6577

BELGIUM  
Phone: +32-2-344-0970  
Fax: +32-2-344-1123

BRAZIL  
Phone: +55-11-2146-3600  
Fax: +55-11-2146-3610

CHINA  
Phone: +86-10-8486-4515  
Fax: +86-10-8486-5305

FRANCE  
Courbevoie  
Phone: +33-1-4904-9000  
Fax: +33-1-4904-9010

GERMANY  
Ratingen  
Phone: +49-2102-108-0  
Fax: +49-2102-108-111

INDIA  
Mumbai  
Phone: +91-22-8354790  
Fax: +91-22-8354791

New Delhi  
Phone: +91-11-2-6164175  
Fax: +91-11-5-1659635

ITALY  
Phone: +39-081-7892-111  
Fax: +39-081-7892-208

JAPAN  
Chiba  
Phone: +81-43-297-9222  
Fax: +81-43-299-1115

KOREA  
Phone: +82-2-2274-0748  
Fax: +82-2-2274-0794

MALAYSIA  
Phone: +60-3-2161-0322  
Fax: +60-3-2163-6312

MEXICO  
Phone: +52-5-310-9863  
Fax: +52-5-310-5584

THE NETHERLANDS  
Phone: +0031-15-3808666  
Fax: +0031-18-1641438

RUSSIA  
Veliky Novgorod  
Phone: +7-8162-55-7898  
Fax: +7-8162-55-7921

Moscow  
Phone: +7 495-585-1276  
Fax: +7 495-585-1279

SAUDI ARABIA  
Phone: +966-3-341-0278  
Fax: +966-3-341-7624

SINGAPORE  
Phone: +65-6861-6100  
Fax: +65-6861-7172

SOUTH AFRICA  
Phone: +27-11-452-1550  
Fax: +27-11-452-6542

SOUTH & CENTRAL  
AMERICA AND THE CARIBBEAN  
Phone: +55-12-2134-1201  
Fax: +55-12-2134-1238

SPAIN  
Phone: +34-93-652-6430  
Fax: +34-93-652-6444

UNITED ARAB EMIRATES  
Phone: +971-4-8991-777  
Fax: +971-4-8991-778

UNITED KINGDOM  
Wooburn Green  
Phone: +44-1628-536300  
Fax: +44-1628-536319

UNITED STATES  
Massachusetts  
Phone: +1-508-586-4600  
Fax: +1-508-427-8971

Corpus Christi, Texas  
Phone: +1-361-881-8182  
Fax: +1-361-881-8246

Deer Park, Texas  
Phone: +1-281-884-1000  
Fax: +1-281-884-1010

Houston, Texas  
Phone: +1-281-671-1640  
Fax: +1-281-671-1735



Visit us online at:  
[www.geoilandgas.com/valves](http://www.geoilandgas.com/valves)

\* Consolidated, ValvKeep and Green Tag Center are registered trademarks of the General Electric Company.  
Other company names and product names used in this document are the registered trademarks or trademarks of their respective owners.

© 2014 General Electric Company. All rights reserved.

GEA19381A 05/2014  
[Formerly Consolidated 19000\_MM]