

COMMERCIAL ALUMINUM

OPERATION &
MAINTENANCE MANUAL



COMMERCIAL

COMMERCIAL
SERIES





CA220 in bronze



CA220 in bronze



CA220 in white

COMMERCIAL ALUMINUM SERIES

CA-220 / CA-110

Commercial Aluminum



Clean Lines.

Haas CA-220 and CA-110 Aluminum Sectional Doors are strong, rugged and durable. A versatile product consisting of aluminum rails and stiles, combined to provide a strong profiled framing structure with aluminum panels and a wide range of glazing choices. This is the ideal application for service stations, quick lube facilities, automobile dealerships and other facilities where strength, appearance and corrosion resistance are key factors.



CA110 in clear anodized

Available Options

- 2" or 3" Track
- Exhaust Port(s)
- Cam Safety Device
- Spring Bumpers
- Chain Hoist
- High Cycle Springs
- Wind Load Rating (220 only)
- High Cycle Rollers
- Pass Door (220 only)
- Top Header Seal
- Car Wash Cutout
- Security Bars

Pass Through Door (exterior view)



Optional Exhaust Port (interior view)



CA Quick Guide

Model	Door Thickness	R-Value	Max. Door Size		End Stile Type	Center Stile	Rails		Panel and Glazing Types
			Width	Height			Meeting	Top & Bottom	
CA-220	1-3/4"	N/A	28'-2"	16'-0"	4" or 6" Aluminum Size Dependant	2" Aluminum	4" Aluminum	4" or 6" Aluminum Size Dependant	Polystyrene & Aluminum Laminated Panels Various Types & Thicknesses of Glazing
CA-110	1 3/4"	N/A	16'-2"	14'-0"	3" Aluminum	1" Aluminum	2" Aluminum	3" Aluminum Upgradable to 4" or 6"	Polystyrene & Aluminum Laminated Panels Various Types & Thicknesses of Glazing

Haas CA-220 Heavy Duty Frame

The CA-220 Commercial Aluminum sections are assembled using .065" minimum aluminum alloy tubular type extrusions with thru-bolt construction. Sections are 1-3/4" thick. Any Section height is available. Bottom rails, top rails and end stiles are 4" on doors up to 18'-2" wide. Doors greater than 18'-2" wide have 6" bottom rails and top rails. All doors wider than 12'-0" have built in struts and doors greater than 18'-2" wide have an additional "T" shaped cap strut. Standard color for the CA-220 is clear anodized; while color anodizing and special paint finishes are optional. Panels for solid sections are .040" stucco embossed or .050" smooth aluminum. A wide variety of glazing materials are available.



Haas CA-110 Narrow Line Frame

The CA-110 Commercial Aluminum sections are assembled using .065" minimum aluminum alloy, tubular type extrusions with through bolt construction. Sections are 1-3/4" thick. Any Section height is available. Bottom rails, top rails and end stiles are 3" on doors up to 13'-11" wide. Doors greater than 13'-11" wide have 4" bottom rails. All doors wider than 12'-0" have built in struts on each section. All aluminum is clear anodized as standard. Color anodizing and special paint finishes are optional. Panels for solid sections are .040" stucco embossed or .050" smooth aluminum. A wide variety of glazing materials are available.



COLOR OPTIONS



Clear Anodized



Bronze Anodized



Black Anodized

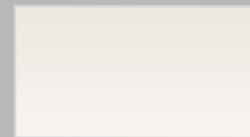

Polar White



Almond



Sandstone

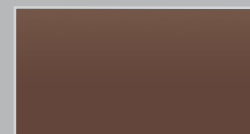

Brown

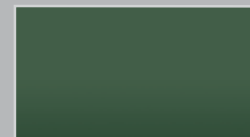

Hunter Green

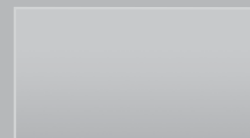

Gray

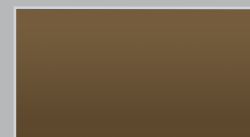

Bronze

Commercial Aluminum

CA-110 available in clear anodized, bronze anodized, black anodized, and polar white only. CA-220 is available in all colors shown.

Installation & Maintenance Service Manual For Commercial Steel Doors

Read Instructions Thoroughly Before Starting Installation

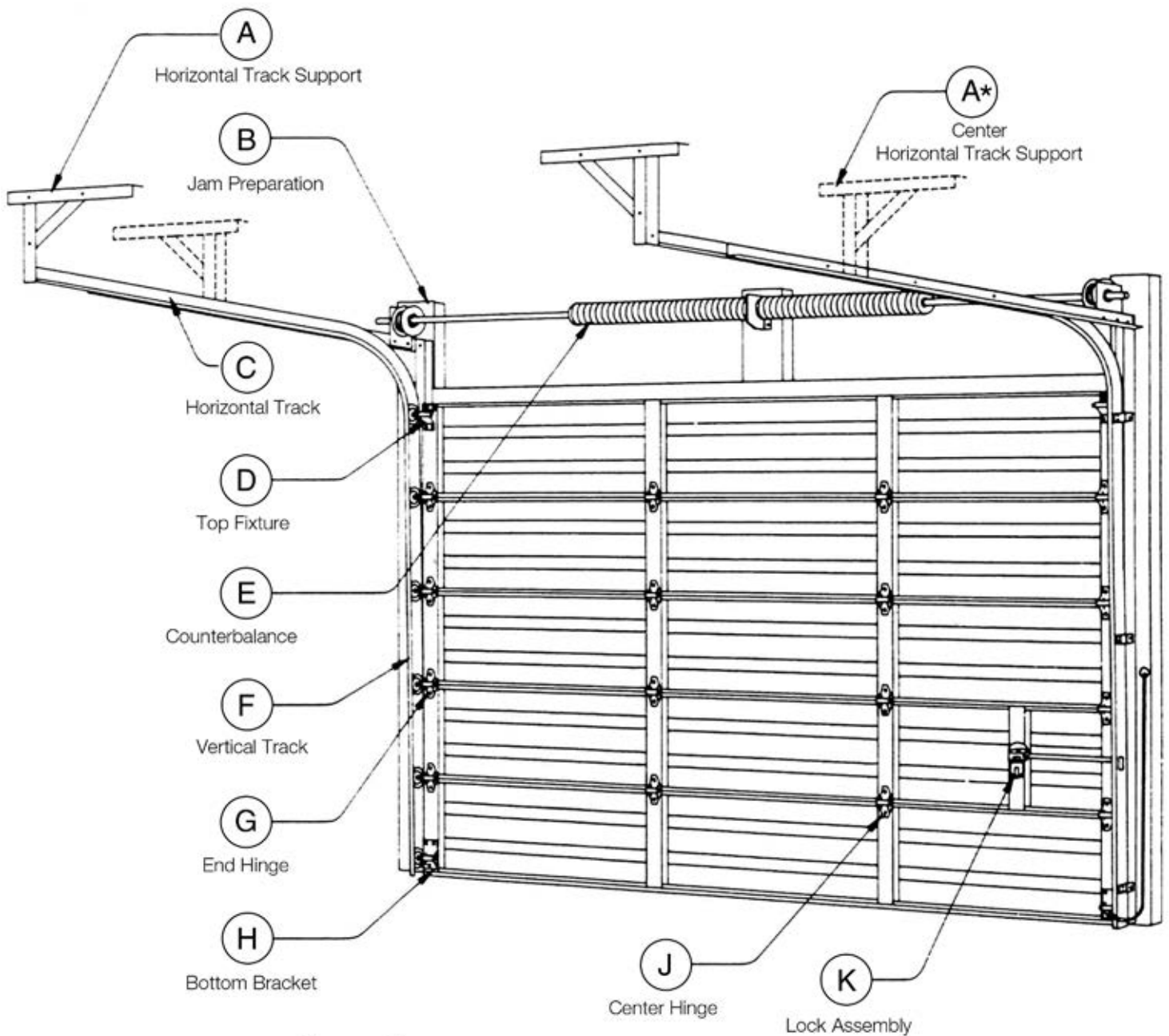
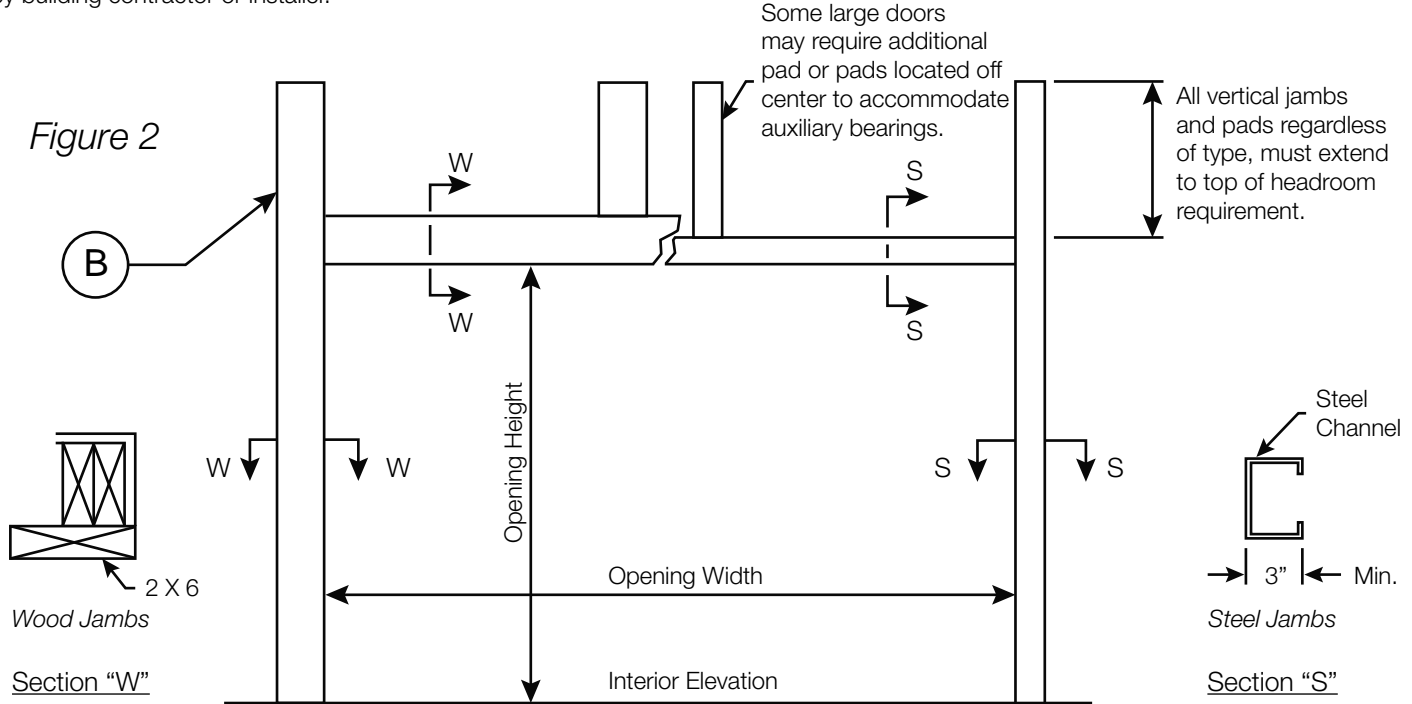

Figure 1

OPENING PREPARATION

Note : All framing materials must be provided by building contractor or installer.



STEP 1 INSTALLATION OF DOOR

Check the size of door to be sure it is the same size as opening. Inspect the track and determine if you have reverse angle or bracket mount tracks. Note: bracket mount has individual j-brackets to attach track to jamb, reverse angle has a continuous angle to attach track to jamb. Note: if door is supplied with reverse angle. The door should be 2" wider than opening.

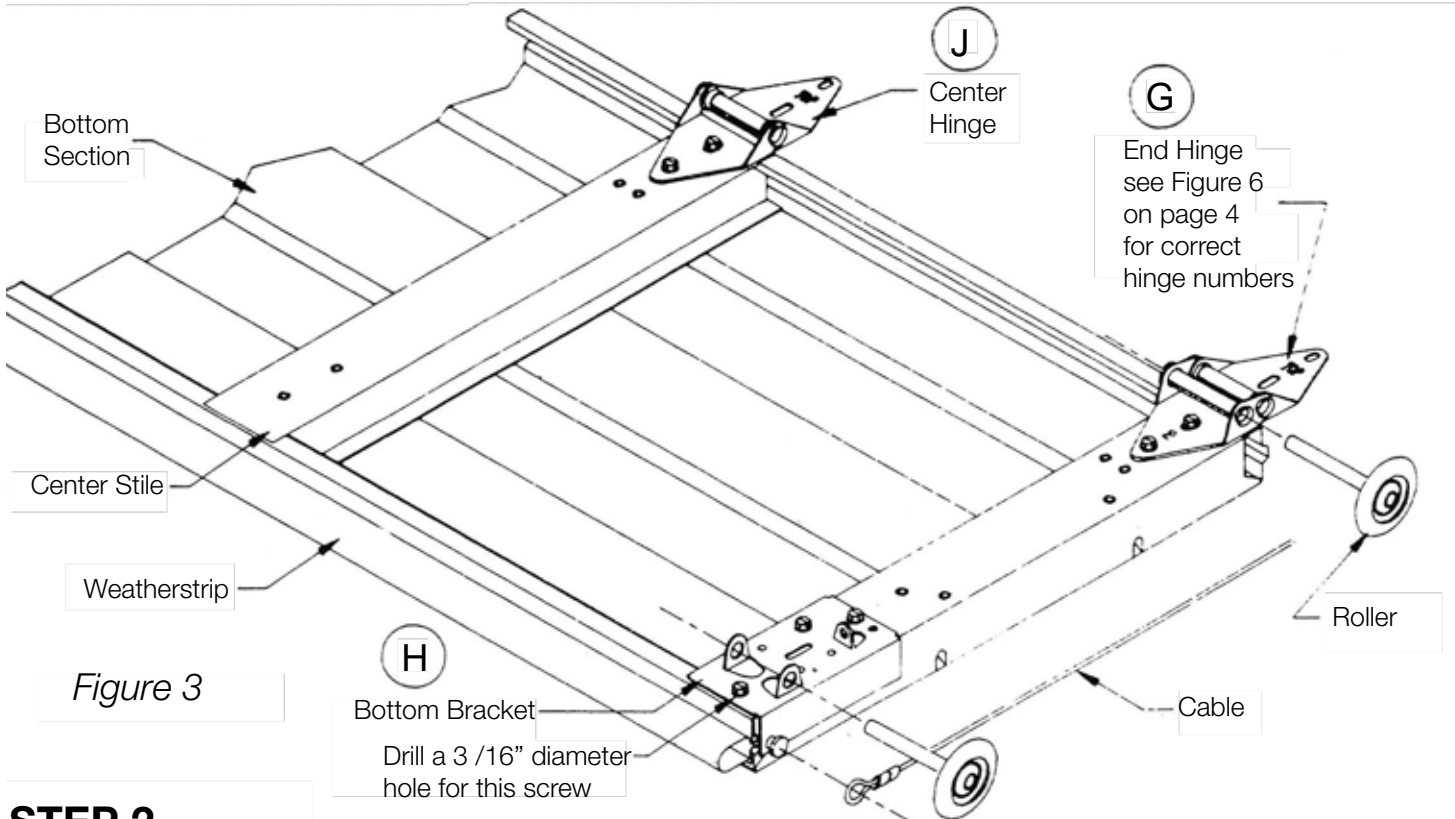

STEP 2

Attach hardware to bottom section with 1/4" x 3/4" hex head sheet metal screws (see Figure 3). If door requires struts (u-bars) see Figure 8 on page 4.

INSTALLATION OF VERTICAL TRACKS

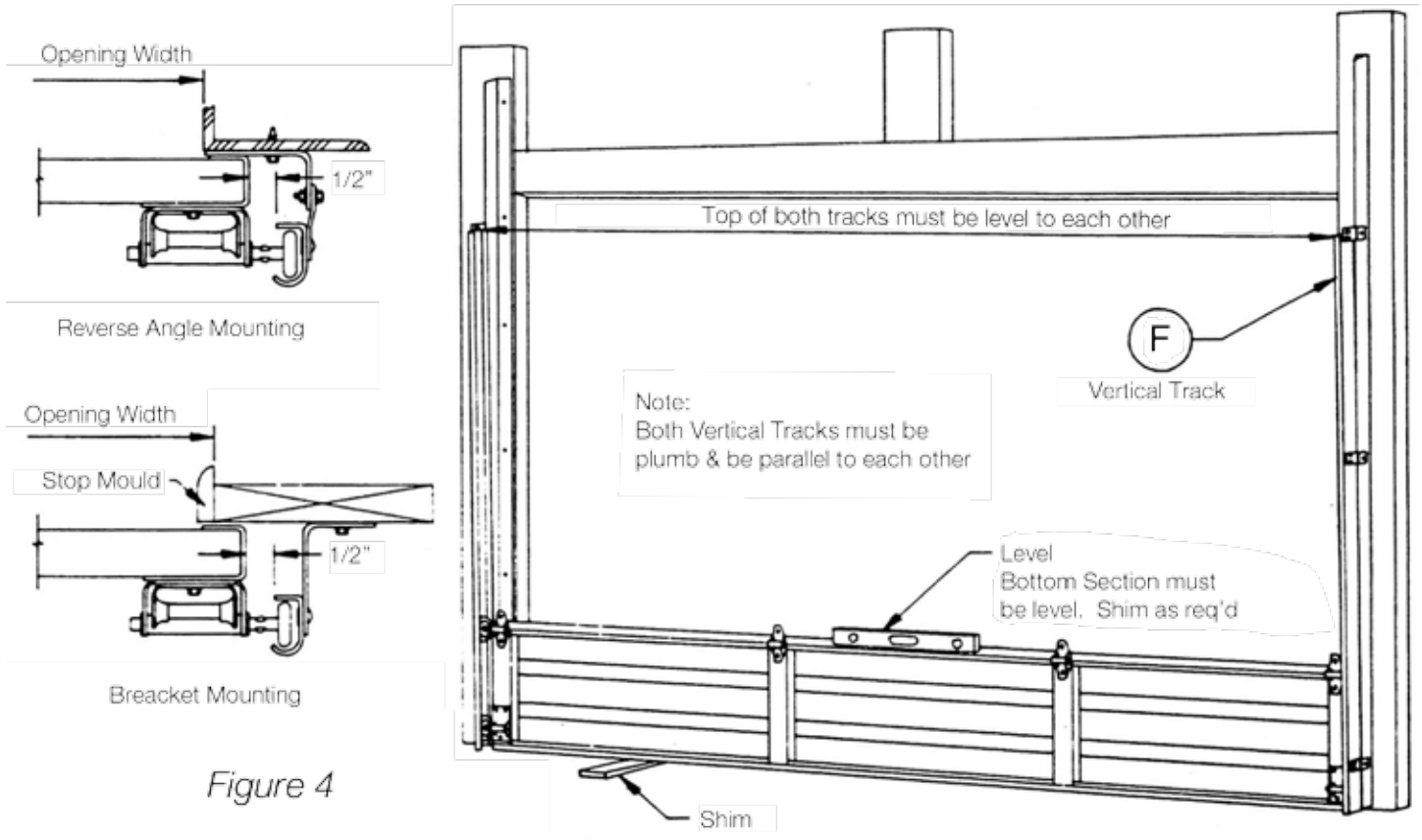

Figure 4

STEP 3

Position bottom section in center of the opening, allowing equal distance from each side of the opening.

STEP 4

Position left hand track over rollers as shown in Figure 4. Space track 1/2" from door as shown.

Before attaching vertical track angle or brackets to jambs it must be plumb and parallel to door and raised to match leveling of bottom door section.

Attach vertical track angles to jambs by welding or by using 1/4" self drilling screws on steel jambs or 5/16" x 1 1/2" hex head lag screws on wood jambs. If mounting directly to masonry, anchors are not supplied.

Repeat above step for right hand track. (Note: Both tracks must be parallel for proper operation)

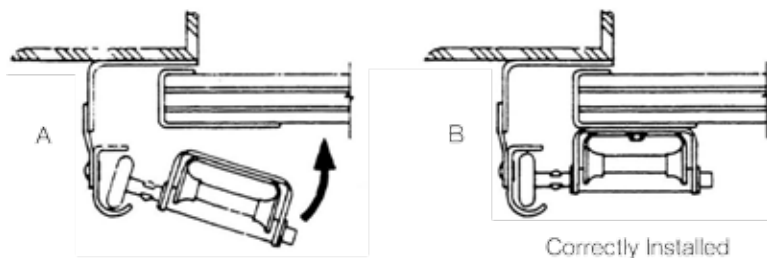

Figure 5

Insert rollers into end hinges. Hook rollers into vertical track and swing end hinges onto door section as shown at left. Secure with fasteners provided.

STEP 5

Place #2 section on top of bottom section. Note: if door is supplied with cylinder lock, use section with lock holes punched or drilled in it (see Step 19 on page 8).

Attach hinges and rollers as shown in Figure 5. See hinge schedule Figure 6 on page 4 for correct placement of numbered hinges. If inside lock is supplied, see Figure 7.

STEP 6

Complete the remainder of the sections at this time. Top door section should only be installed after horizontal track or full vertical track has been installed.

Note: if door is supplied with full view aluminum section(s), attach hinges with 1/4" self drilling screws provided.

STEP 7 SLIDE BOLT LOCK

The inside lock is installed on the end stile of the second section so the slide bolt rests against the top of one of the rectangular engaging slots in the vertical track (see Figure 7). If door is supplied with cylinder lock, see page 8.

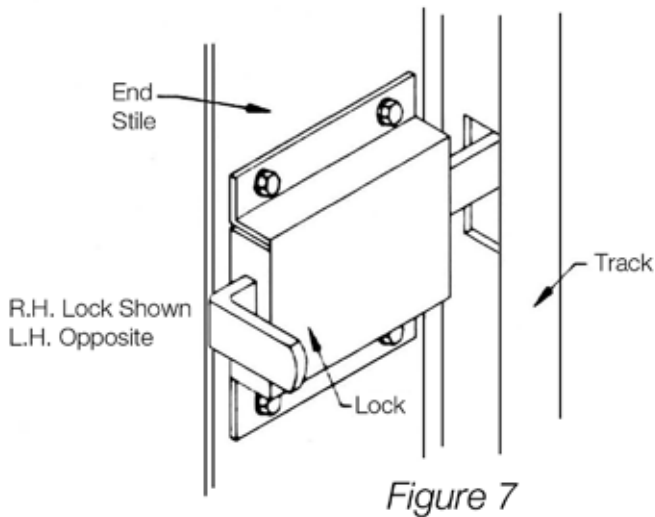

STEP 8 U-BAR INSTALLATION

All trusses (u-bars) except top section truss are attached with tech screws below hinges as shown in Figure 8. Top section truss is located directly above the top roller brackets, secured at the ends with tech screws. Secure all trusses to center stiles through existing holes utilizing tech screws.

Note: Doors over 14'-2" wide require one truss per section.

HINGE SCHEDULE

Figure 6

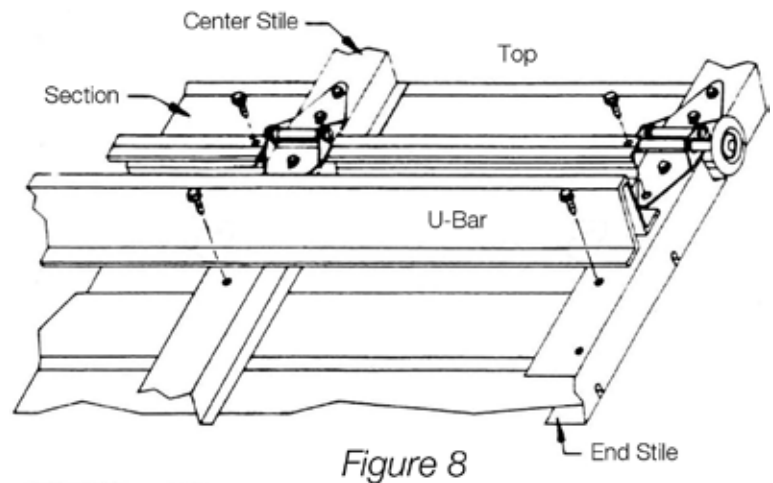
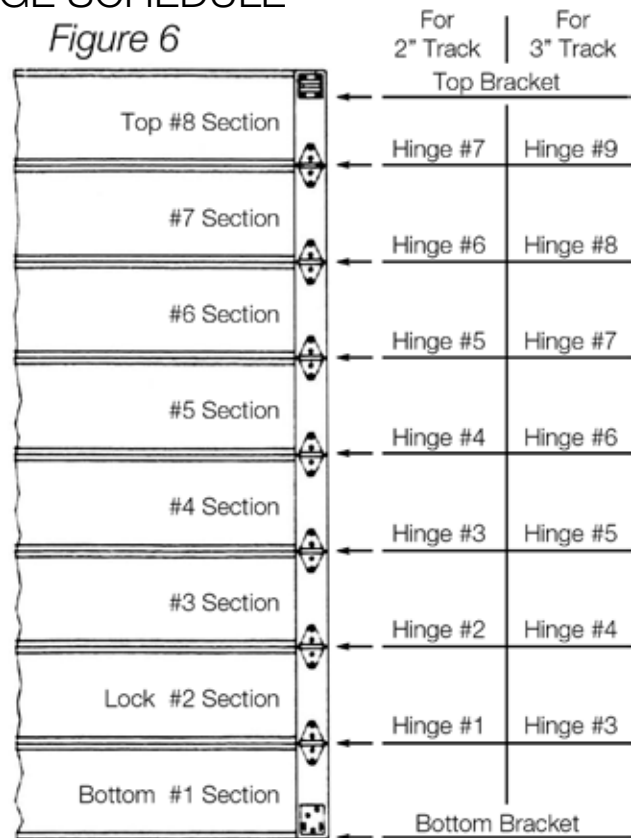

STEP 9 STANDARD LIFT TRACK

Attach bearing brackets to the horizontal angles with 3/8" x 3/4" bolts & nuts. Form rope loops to a convenient overhead structural member & insert horizontal tracks through them, then attach bottom of the curved portions of track to the top of the vertical tracks at the splice brackets with 1/4" x 5/8" truss head machine screws & nuts. Head of machine screws should be to inside of the track (see Figure 9). Using a level, strike a plumb line from the inside of the splice bracket to the inside of the horizontal angle on each side. Place outside edges of bearing brackets against the plumb lines and attach brackets securely to the wall (see Figure 9).

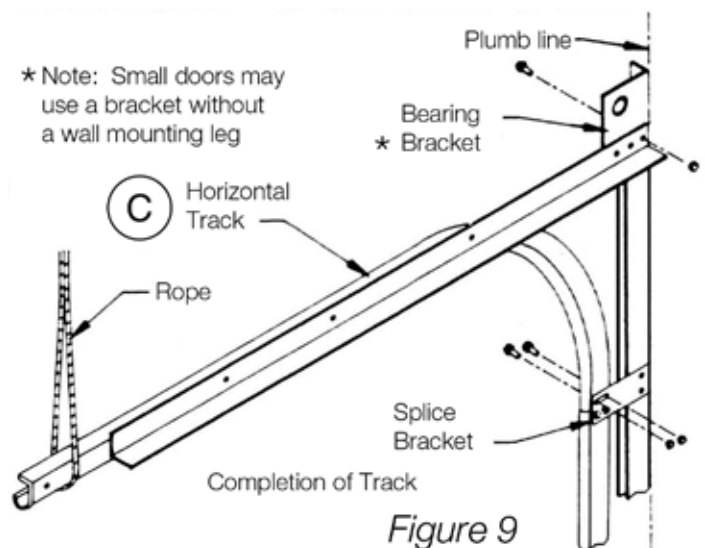

STEP 9a HI-LIFT TRACK

Connect vertical hi-lift track to top of existing vertical track with 1/4"x 5/8" truss head machine screws. Set track plumb and fasten to jamb in the same manner as the vertical track previously installed in Step 4. Attach bearing brackets to the horizontal angles with 3/8" x 3/4" bolts & nuts. Form rope loops to a convenient overhead structural member and insert horizontal tracks through them, then attach bottom of the curved portions of track to the top of the vertical tracks at the splice brackets with 1/4" x 5/8" truss head machine screws and nuts. Head of machine screws should be to inside of the track (see Figure 9a). Using a level, strike a plumb line from the inside of the splice bracket to the inside of the horizontal angle on each side. Place outside edges of bearing brackets against the plumb lines and attach brackets securely to the wall (see Figure 9a).

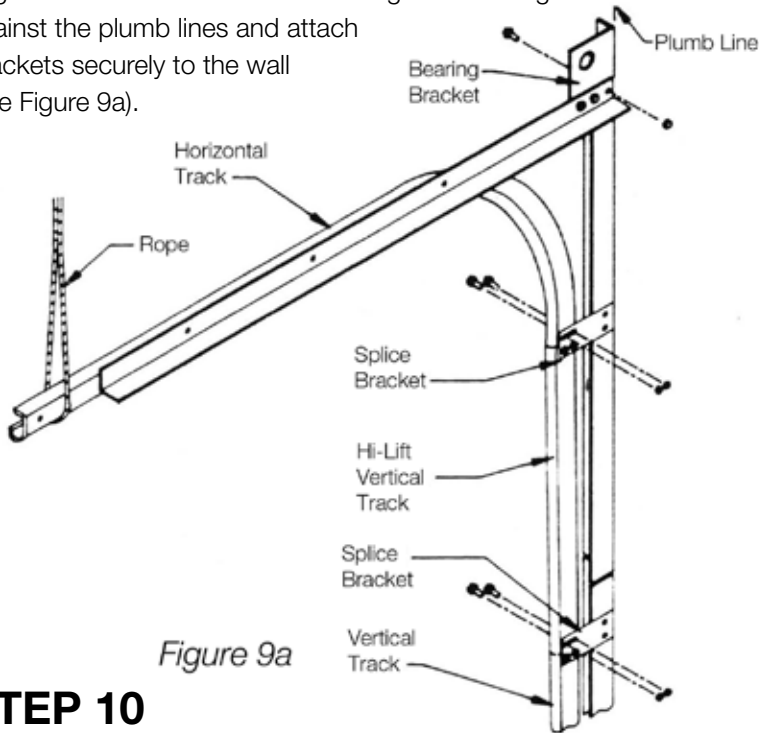

Figure 9a

STEP 9b VERTICAL LIFT TRACK

Place upper vertical track on top of lower vertical track. Plumb track and attach to wall in same manner as lower vertical tracks. Heads of machine screws should be to inside of the tracks as shown in Figure 9b. (Jamb fasteners must be installed with no more than 48" between each fastener.) Now set bearing brackets against the plumb lines and attach brackets securely to the track and wall.

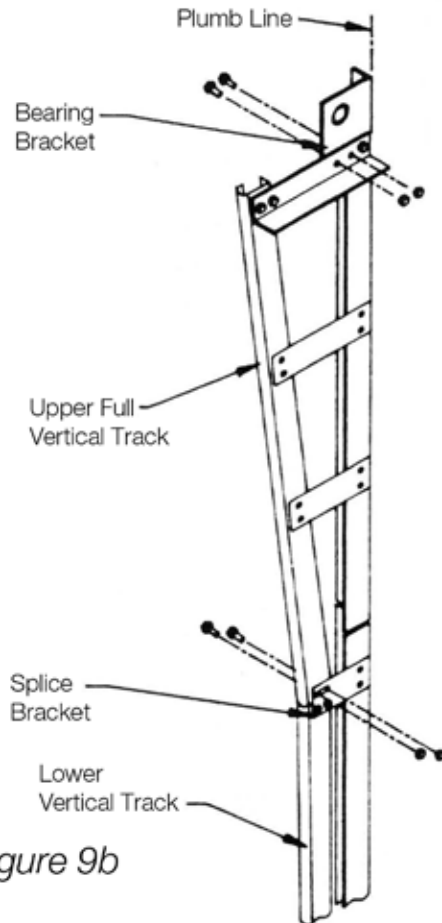

Figure 9b

STEP 10 HORIZONTAL TRACK SUPPORT

Replace temporary support hangers with steel support angle (not supplied). Install sway braces only after checking the horizontal track with a tape measure or spacing bar to verify that they are parallel. Important: steel support or other means must be strong enough to support full door weight and must be attached to a structurally sound member.

Note: a center horizontal track support is required for doors larger than 12'-1" in height (see Figure 1 Item A on page 1).

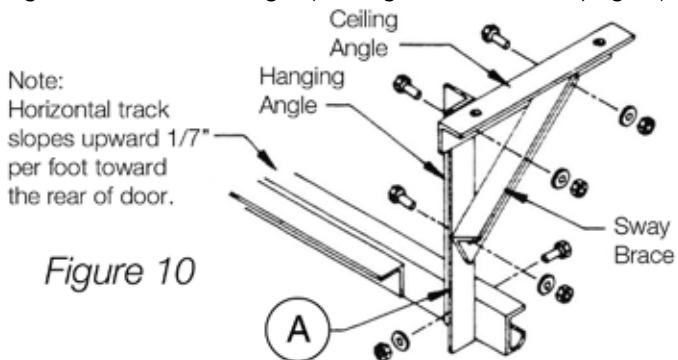

Figure 10

STEP 11 TOP BRACKETS

Place top section in position. With rollers inserted in the sleeves of top roller brackets, bolt brackets to section through holes provided, utilizing self-tapping screws. Adjust bracket slide so top section is perfectly vertical and tighten adjusting bolt securely. Attach top leaves of hinges from the preceding section. Check tracks for proper clearance and permanently secure all fasteners.

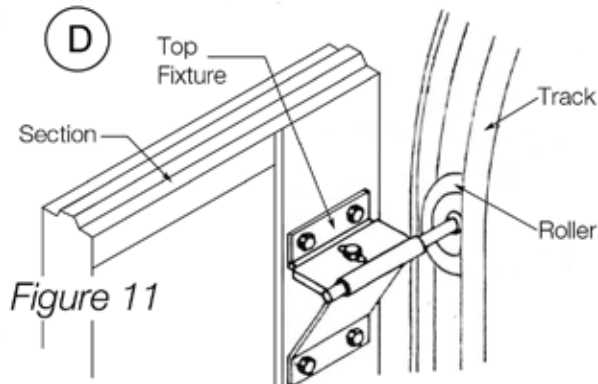

Figure 11

WARNING:

Installing torsion springs can be a dangerous procedure and should only be performed by qualified door service personnel. Do not attempt installation without proper tools and until reading and understanding the following instructions.

STEP 12 COUNTERBALANCE INSTALLATION

Determine what type of spring assembly you have as shown in figures 12, 13, 14 or 15.

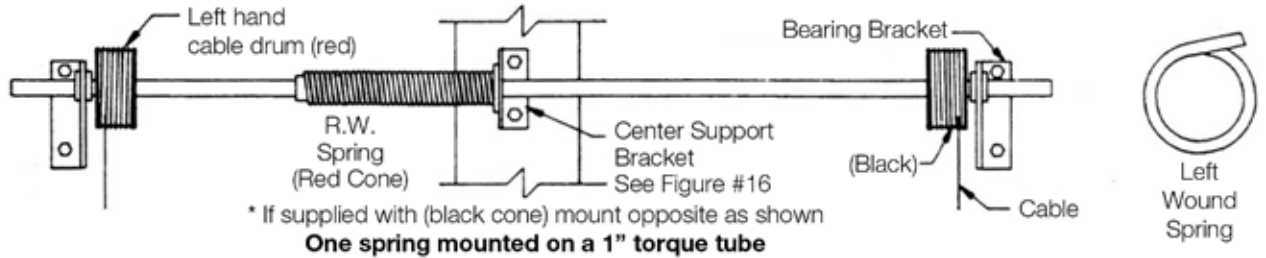

Figure 12

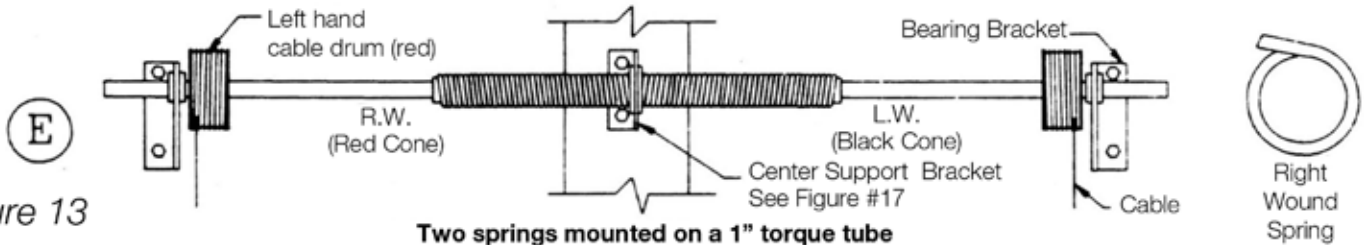

Figure 13

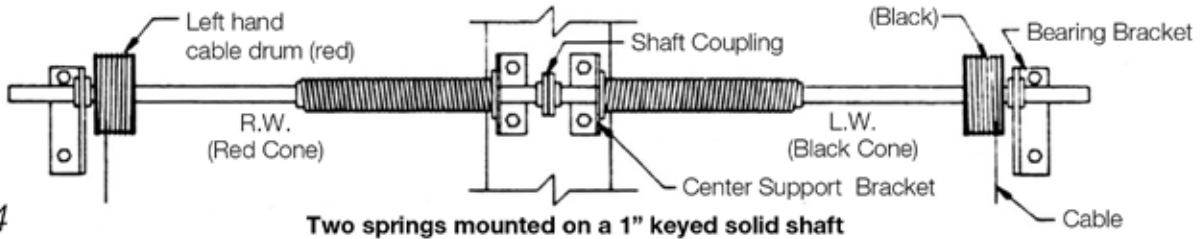

Figure 14

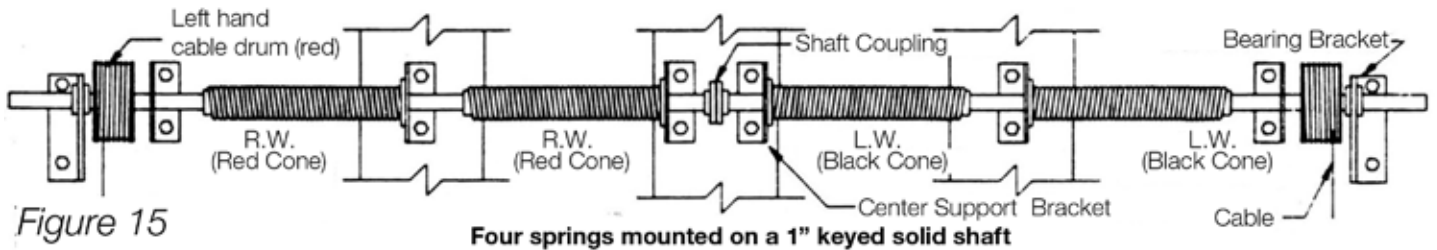
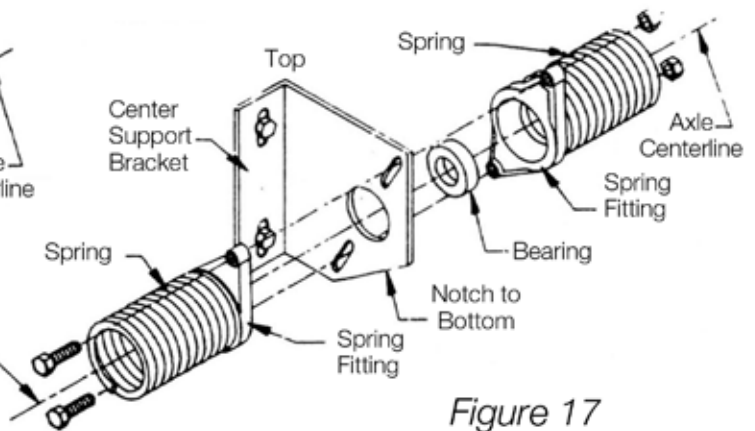
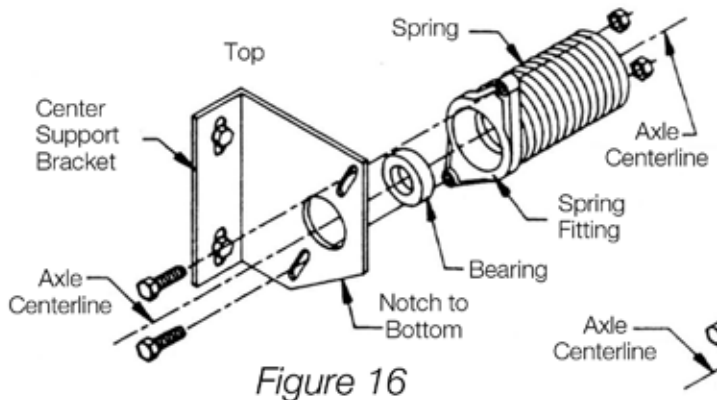

Figure 15

STEP 13

Place the center support bracket and the bearing on the axles as shown in Figure 16 (bearing sits inside spring fitting). Bolt spring fitting(s) to center support bracket (see Figure 16 or 17) using 3/8" dia. x 1 1/2" hex head bolts. Slide a cable drum on both ends of shaft. Be sure correct hand drum is used (see Figures 12 thru 15). Slide bearing on each shaft end if not already bolted to track.



STEP 14

Raise the shaft assembly over the door. If 2 piece shaft with coupling is supplied, raise half the total shaft at a time. Rest the end(s) of shaft on the horizontal track angle.

See Figure 19 For coupling installation.

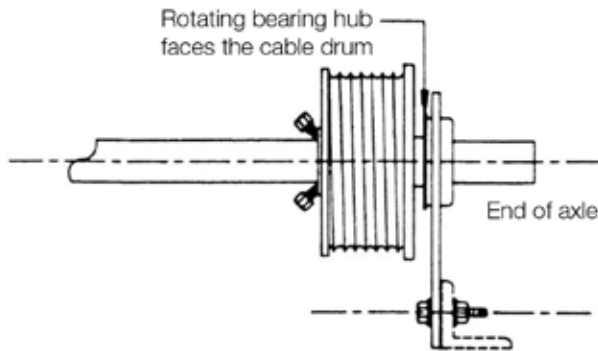

Figure 18

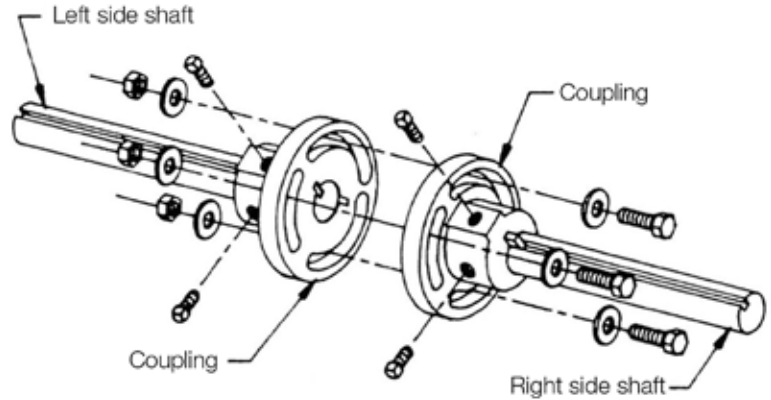

Figure 19

STEP 15

Locate and attach spring bearing plates/center support bracket to mounting pads (not supplied). See Figure 2 for wood or steel frame (jamb) . Mount spring brackets to structural member of building of sufficient size to withstand spring(s) torque. When mounting springs on pads, keep in mind that springs grow in length when wound. Allow at least 5" space between spring fitting and cable drum. If mounting the center support bracket to wood, use (2) 5/16" x 1 5/8" long hex head lags for each bracket. For steel jambs use (2) 3/8" x 1 1/2" hex head bolts. If mounting directly to concrete use (2) 5/16" dia thru bolts or threaded rods (not supplied).

STEP 16 ATTACHING THE CABLES

Thread each cable between the axle and wall. Then insert each cable into the entry slot of each drum. Wind the excess cable on the drum, then slide the drum against the bearing plate and tighten the two set screws securing the drum to the shaft. Clamp a set of locking pliers with the jaws locked onto the shaft and the other end against the wall so that cable tension on the drum is taut (no slack) and the shaft locked. Secure the remaining drum making sure both cables have equal tension and are taut (see Figure 20). If axle is a solid shaft use a 1/4" key for both drums.

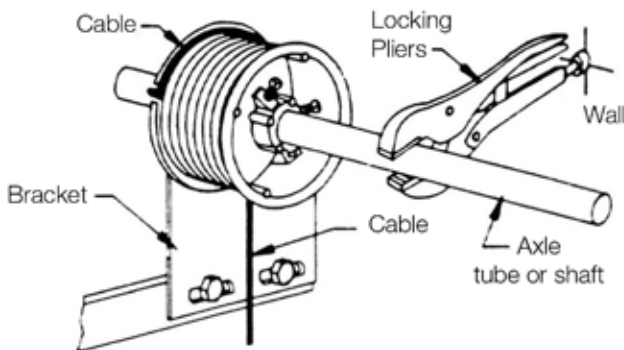

Figure 20

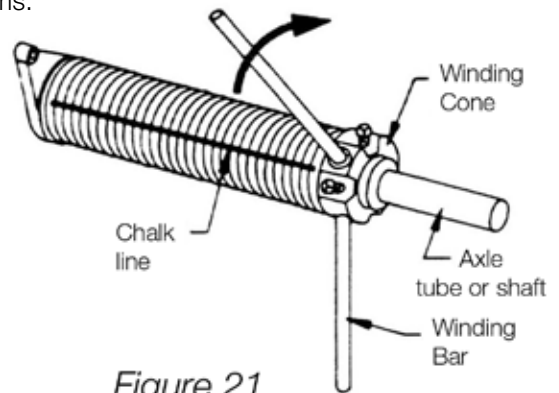

Figure 21

STEP #17

Before going to Step 18. Be sure door is in locked position. If no lock is supplied, place a clamp in both tracks of door directly above a roller to make sure door can not be raised at this time.

STEP # 18 WINDING SPRING (see Figure 21)

Note: garage door springs can cause serious injury if not handled properly. Before winding the springs, make sure the lock is engaged in the "locked" position. This will prevent the door from raising up by itself in the event the springs are over wound or are too strong . Use two cold rolled steel rods approximately 18" long and the same diameter as the holes in the winding cones (winding rods not furnished) 1/2" dia. for 1 3/4" & 2 5/8" springs and 5/8" dia. for larger springs. Do not use undersized rods or other tools to wind springs. For your safety, position yourself on a sturdy ladder so that winding cone is either to your right or to your left. Never stand directly in front of winding cones or winding bars. With one hand, insert one winding rod all the way into the hole of the winding cone and wind the spring up one-quarter turn. With your other hand, insert the second winding bar into the next hole, remove the upper winding bar and then take another one-quarter turn. Proceed in this manner until you have made all the required number of turns. The number of turns are indicated on the spring tag attached to the spring assembly. For example, if the tag says "wind spring 7 turns, 7 x 4 = 28 one-quarter turns are required to balance. Note: each complete turn will cause the chalk line to make one spiral. After the required number of 1/4 turns have been made, tighten both set screws in the winding cone to secure it to the shaft before removing the winding bars. Repeat this procedure for each spring, then locking pliers can be removed. Attach one red warning label to spring.

STEP 19 CYLINDER LOCK INSTALLATION

If lock cylinder is supplied, install in lock section as shown in the exploded view (see Figure 22).

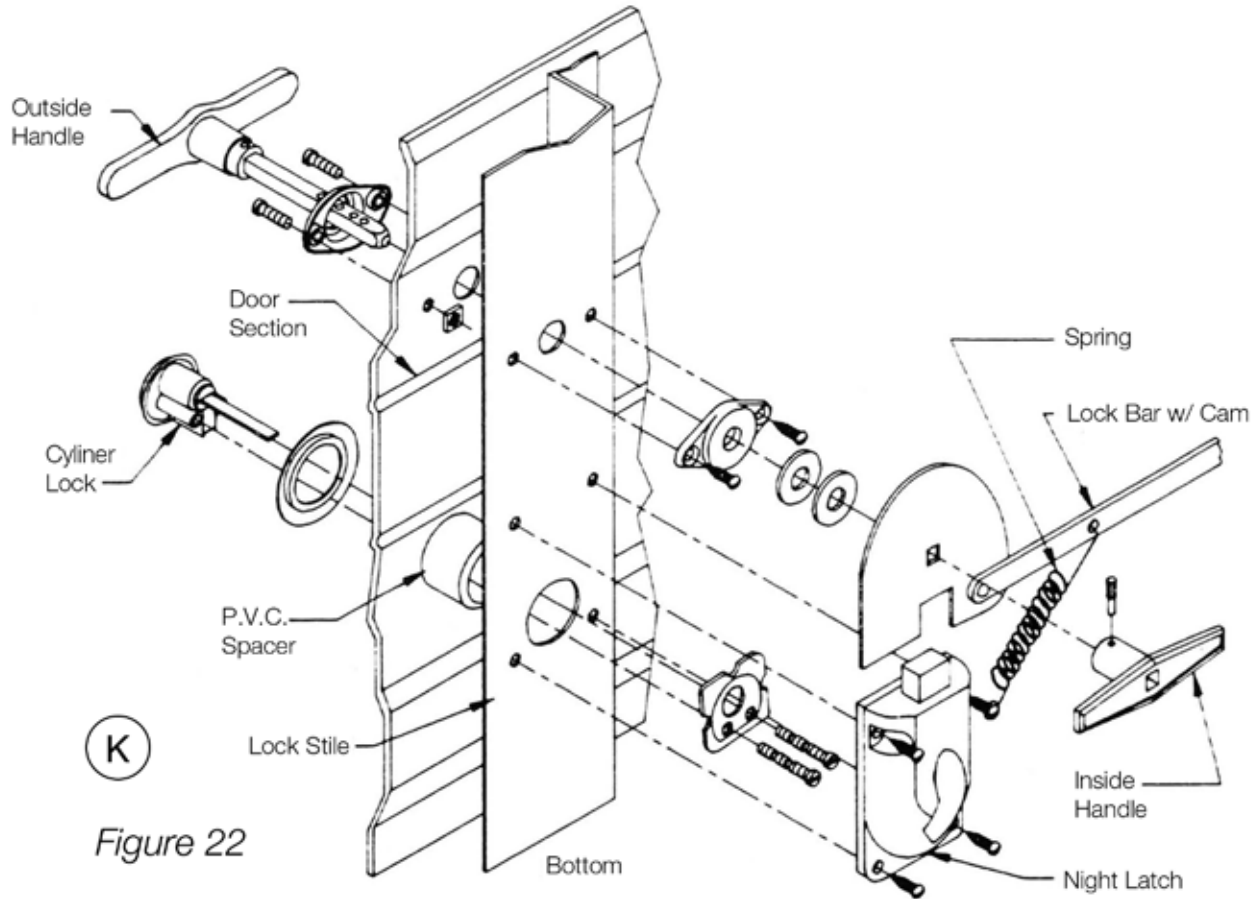

Figure 22

STEP #20 LIFT HANDLES

Install lift handle(s) on bottom section with 1/4" - 20 nuts and bolts supplied (as shown in fig. # 23).

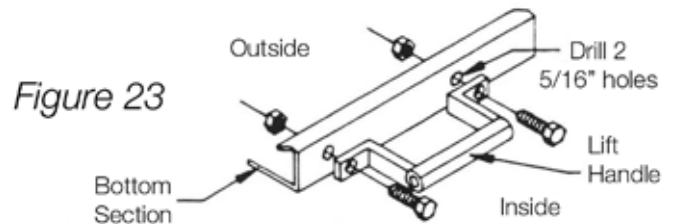

Figure 23

MAINTENANCE & CAUTIONS

Recommended Service: lubricate rollers with a light oil as required. Check and tighten all nuts, bolts and screws annually. (This may be required more frequently for high usage doors.)

Haas Door recommends servicing any part of the counterbalance system including springs, drums cables, bearing brackets, and bottom corner brackets where cable is attached be performed by qualified door service personnel only (see notice below).

Important Safety Notice: Operate door only when properly adjusted and free of obstructions. Door is under extreme spring tension. Repairs and adjustments, especially to cables and spring assembly, can be hazardous and should be performed by qualified door service personnel only.

Do not permit children to play with garage door or electric controls.

If door is now, or later becomes, electrically operated, pull down rope must be removed.

Avoid standing in open doorway or walking thru doorway while electrically operated door is moving.

Should door become hard to operate or completely inoperative, it is recommended that a qualified door agency be contacted.

The notice above has been approved and recommended by the National Association of Garage Door Manufacturers (NAGDM).

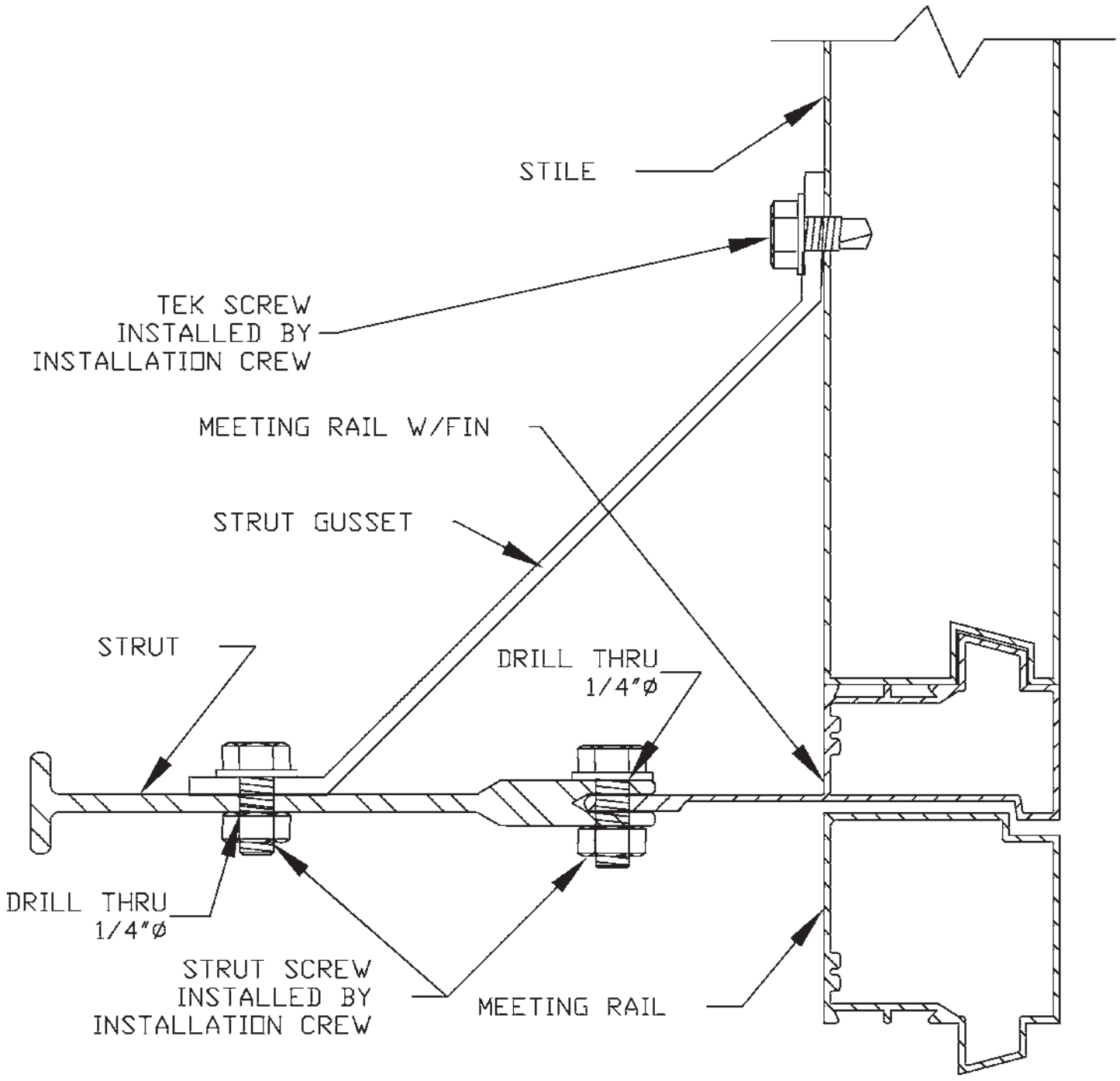

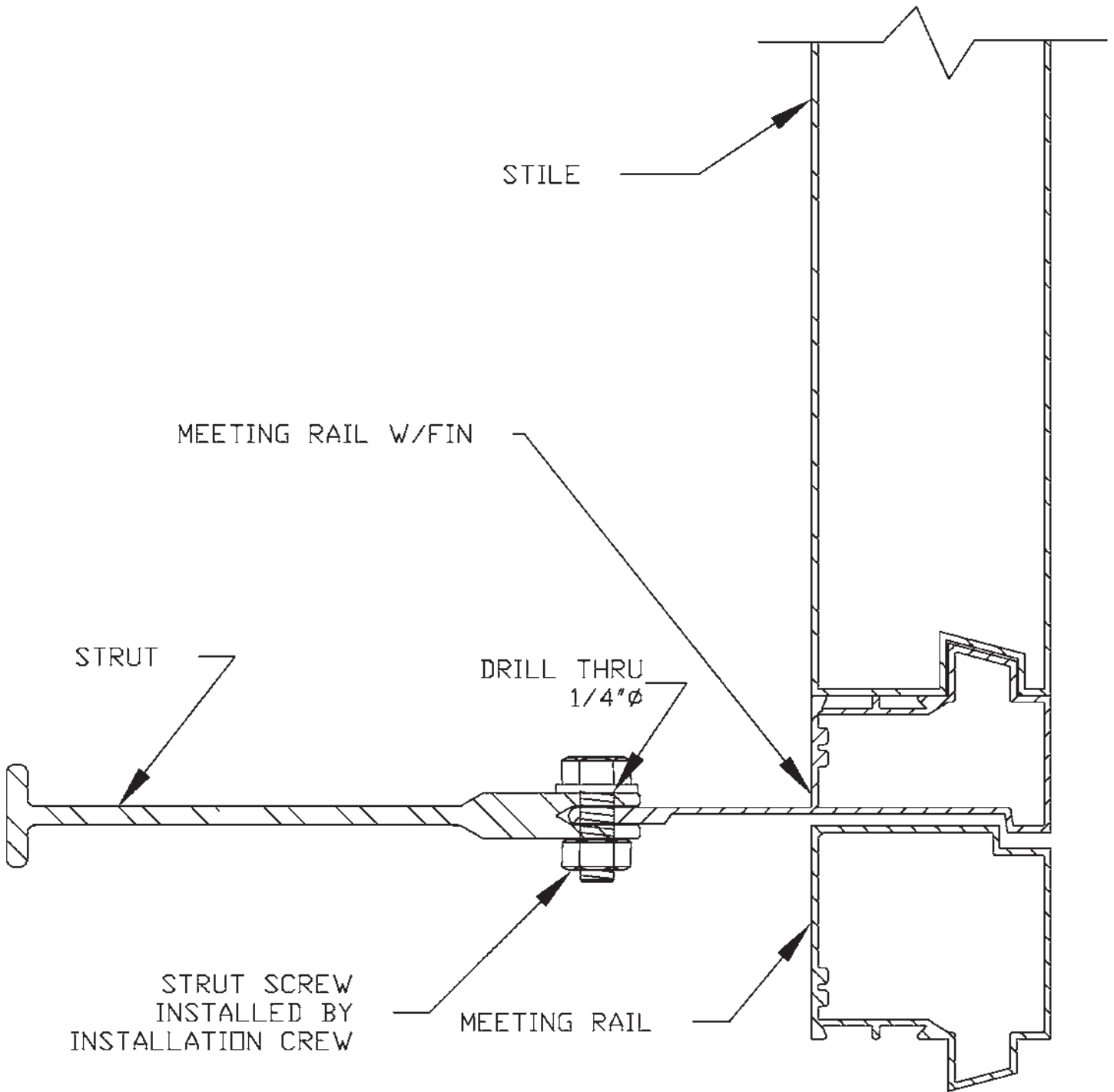



CA-110 / CA-220 COMMERCIAL ALUMINUM GARAGE DOORS

Haas Door Company warrants its commercial models CA-110 and CA-220 series aluminum garage door sections to be free from defects in workmanship and material for a period of one (1) year from date of installation.

This Warranty applies only to aluminum garage door sections manufactured by Haas Door Company and components manufactured or supplied by Haas Door Company. The warranty excludes: (1) Sections and/or component parts which have been damaged due to misuse; (2) Sections and/or components which have been improperly installed, maintained or operated; (3) Sections and/or components that have been damaged due to accident; (4) Sections and/or components that have been damaged due to exposure to corrosive fumes/chemicals, alkaline cleaning agents, condensation or fire; (5) Performance of coatings used to finish the garage door sections; (6) Repair and/or replacement labor charges, including travel cost; (7) Damages resulting from other causes beyond the manufacturers control.

In the event any defect is claimed during the warranty periods, a claim in writing must be submitted to Haas Door Company, directed through an authorized Haas Door Company dealer or installer. This claim must be submitted within fifteen (15) days of the discovery of the suspected defect. The door and all components must be available for inspection by an authorized Haas Door Company representative. Upon verification of a manufacturing defect, Haas Door Company will provide repair or replacement part(s) at its option.

THE MANUFACTURER SHALL NOT BE RESPONSIBLE FOR ANY INCIDENTAL OR CONSEQUENTIAL DAMAGES ARISING OUT OF ANY BREACH OF THIS EXPRESS LIMITED WARRANTY, including but not limited to any damage to buildings, other property or for any injuries or damages sustained by any person whomsoever, or the recovery of any direct or indirect costs such as shipping, travel, lost time, installation labor charges, paint or painting, cleaning, repair, or other building materials.

This warranty gives you specific legal rights and you may also have other rights that may vary from state to state. Haas Door Company does not authorize anyone to change or modify the above warranties in any respect. **ANY IMPLIED WARRANTY OR MERCHANTABILITY OR FITNESS FOR A PARTICULAR PURPOSE APPLICABLE TO THE COMMERCIAL MODEL(S) OF ALUMINUM OVERHEAD GARAGE DOORS IS LIMITED IN DURATION TO THE DURATION OF THE HAAS DOOR COMPANY WRITTEN WARRANTY SET FORTH ABOVE AND NEITHER HAAS DOOR COMPANY NOR ANY AUTHORIZED SELLING DEALER SHALL BE LIABLE FOR LOSS OF TIME, INCONVENIENCE, COMMERCIAL LOSS, OR OTHER CONSEQUENTIAL OR INCIDENTAL DAMAGES.** Some states do not allow limitations on how long an implied warranty will last or the exclusion or limitation of incidental or consequential damages, particularly in consumer transactions, so the above limitations or exclusions may not apply to you.

----- THIS WARRANTY IS NOT TRANSFERABLE -----