

TYLER

series
Advantage

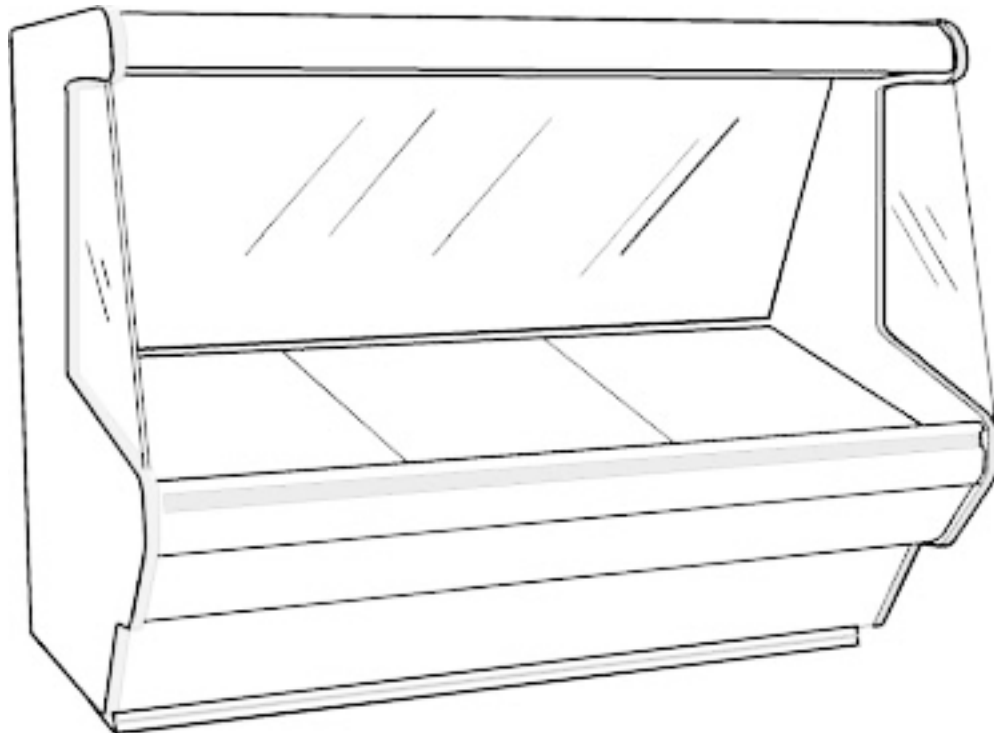

Installation & Service Manual



L3PL, L3PH

WATERFALL PRODUCE MERCHANDISERS
Medium Temperature Refrigerated Display Cases

This manual has been designed to be used in conjunction with the General
Installation & Service Manual.

Save the Instructions in Both Manuals for Future Reference!!

This merchandiser conforms to the Commercial Refrigeration Manufacturers Association Health and Sanitation standard CRS-S1-96.

PRINTED IN U.S.A.	Specifications subject to change without notice.	REPLACES EDITION	1/97	ISSUE DATE	7/99	PART NO.	9027537	REV.	B
-------------------	--	------------------	------	------------	------	----------	---------	------	---

CONTENTS

	<u>Page</u>
Specifications	
L3PL/L3PH Specification Sheets	4
Pre-Installation Responsibilities	(See General I&S Manual)
Installation Procedures	
Carpentry Procedures	6
Case Pull-Up Locations	6
Electrical Procedures	6
Plumbing Procedures	(See General I&S Manual)
Refrigeration Procedures	(See General I&S Manual)
Defrost Information	6
Defrost Control Chart	6
Installation Procedure Check Lists	(See General I&S Manual)
Wiring Diagrams	
L3PL/L3PH Domestic & Export (50Hz) Case Circuits	7
Canopy Lighting Circuits	9
Optional Shelf Lighting Circuits	10
Cleaning and Sanitation	(See General I&S Manual)
General Information	
Mirror Installation	11
Water Spray Accessories	11
Produce Handling Tips	12
Service Instructions	
Preventive Maintenance	(See General I&S Manual)
Ballast and Lighting Locations	15
Parts Information	
Operational Parts List	15
Cladding and Trim Parts List	16
TYLER Warranty	(See General I&S Manual)

The following Medium Temperature Waterfall Produce Merchandiser models are covered in this manual:

MODELS	DESCRIPTION
L3PL	8' & 12' WATERFALL LOW FRONT PRODUCE MERCHANDISER
L3PH	8' & 12' WATERFALL HIGH FRONT PRODUCE MERCHANDISER

SPECIFICATIONS

L3PL/L3PH Waterfall Produce Merchandiser Specification Sheets

MODEL	L3PL/L3PH
USAGE	BULK PRODUCE
BTUH/FT	900
SUCTION*	+20F
ENTER AIR	+38F

THE ABOVE RATINGS ARE FOR COMPRESSOR SELECTION ONLY. FOR ENERGY CALCULATION DATA REFER TO THE ENERGY SECTION.

NOTE: FOR COMPRESSOR SIZING INFORMATION REFER TO THE "GOLD" SECTION & FOR LINE SIZING INFORMATION REFER TO THE "BUFF" SECTION OF THE TYLER SPECIFICATION GUIDE.

DEFROST CONTROL			PRESSURE SETTINGS		EPR SETTINGS	
PER DAY	MODE	TIME	CUT IN	CUT OUT	R22	R404A
3-4	TIME OFF	40 MIN.	65-68# @ R22	45-54# @ R22	43#	---
			81-84# @ 404A	56-68# @ 404A	---	55#

CASE-TO-CASE SUCTION LINE SUB-FEED BRANCH LINE SIZING																		
	8'	12'	16'	20'	24'	28'	32'	36'	40'	44'	48'	52'	56'	60'	64'	68'	72'	76'
R22	5/8"	5/8"	7/8"	7/8"	7/8"	7/8"	7/8"	1 1/8"	1 1/8"	1 1/8"	1 1/8"	1 1/8"	1 1/8"	1 1/8"	1 1/8"	1 3/8"	1 3/8"	1 3/8"

CASE BTUH REQUIREMENTS are calculated to produce approximately the indicated entering air temperature with absolute maximum operating ambient limits of **75F & 55RH**.

The information contained herein is based on technical data and tests which we believe to be reliable and is intended for use by persons having technical skill, at their own discretion and risk. Since conditions of use are outside Tyler's control, we can assume no liability for results obtained or damages incurred through the applications of the data presented. SPECIFICATIONS ARE SUBJECT TO CHANGE WITHOUT NOTICE.

L3PL/L3PH Waterfall Produce Merchandiser

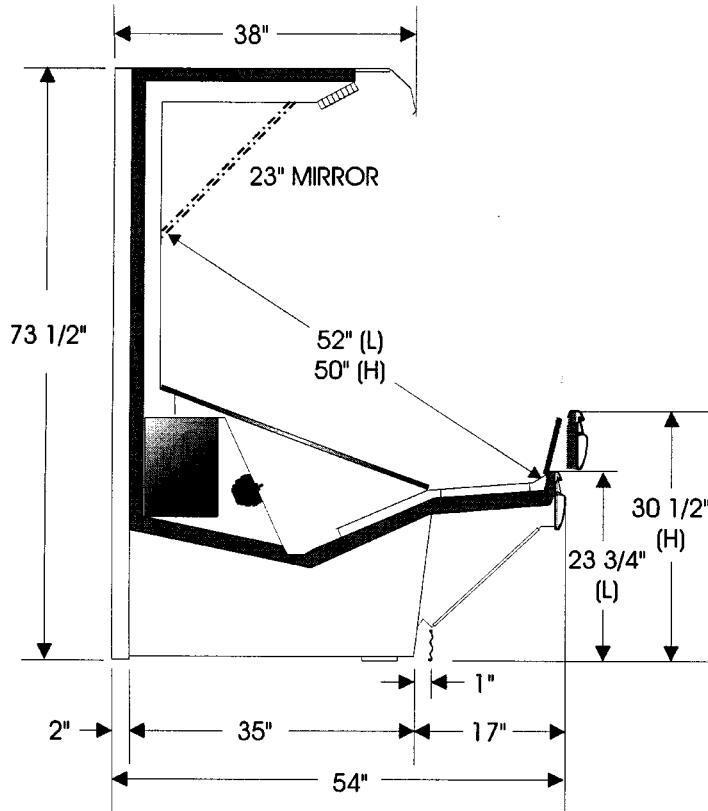

120 VOLT ELECTRICAL DATA (AMPS)		
LENGTH	STD. FANS	ECM FANS
8'	1.2	.4
12'	1.8	.6

STANDARD 120 VOLT LIGHTING (AMPS) T-8/ ELECTRONIC BALLASTS (CANOPY)		
ROW	8'	12'
1	.6	.9

OPTIONAL 120 VOLT LIGHTING (AMPS) T-8/ ELECTRONIC BALLASTS (SHELVES)		
ROW	8'	12'
1	.9	1.3
2	1.4	2.1
3	1.8	2.6

NOTE: L3PL front height is 30 3/4" to top of standard front fence.

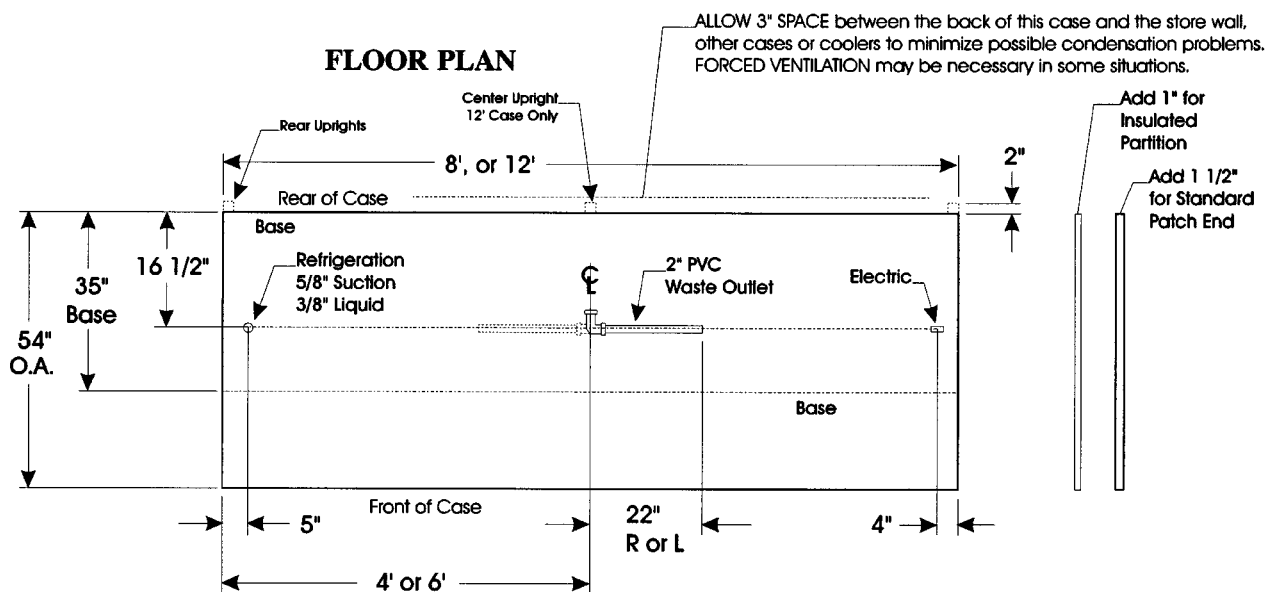

INSTALLATION PROCEDURES

Carpentry Procedures

Case Pull-Up Locations

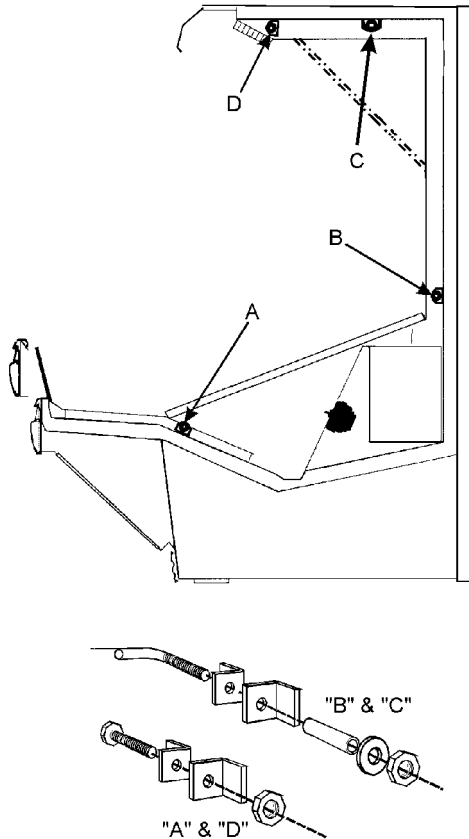

The L3PL and L3PH models have four pull-ups at each end of the case. Pull-ups A, B, C and D are located as shown and should be installed and tightened starting with A and finishing with D.

See "General I&S Manual" for line-up assembly instructions.

Electrical Procedures

Electrical Considerations

CAUTION

Make sure all electrical connections at components and terminal blocks are tight. This will prevent burning of electrical terminals and/or premature component failure.

NOTE

The raceway houses the electrical wiring, components and terminal blocks for the case. Remove the lower front cladding to access the raceway.

Case Fan Circuit

This circuit is to be supplied by an uninterrupted, protected 120V circuit. The case fan circuit is not cycled during defrost on any of these models.

Fluorescent Lamp Circuit

L3PL and L3PH case lighting is supplied by T-8 electronic ballast lights. It is controlled by a light switch in each case. The standard lighting is 1-row of T-8 canopy lights. Optional lighting includes 2-row T-8 canopy lights and up to 3 rows of optional shelf lights.

Defrost Information

See "General I&S Manual" for operational descriptions for Off Time defrost control.

Defrost Control Chart

Defrost Type	Defrosts Per Day	Defrost Duration (Min)	Term. Temp.
Off Time	3-4	40	-----

WIRING DIAGRAMS

ELECTRICIAN NOTE - OVERCURRENT PROTECTION

120V circuits should be protected by 15 or 20 Amp devices per the requirements noted on the cabinet nameplate or the National Electrical Code, Canadian Electrical Code - Part 1, Section 28. 208V defrost circuits employ No. 12 AWG field wire leads for field connections. On remote cases intended for end to end line-ups, bonding for ground may rely upon the pull-up bolts.

L3PL/L3PH Domestic & Export (50Hz) Case Circuits (8' Cases)

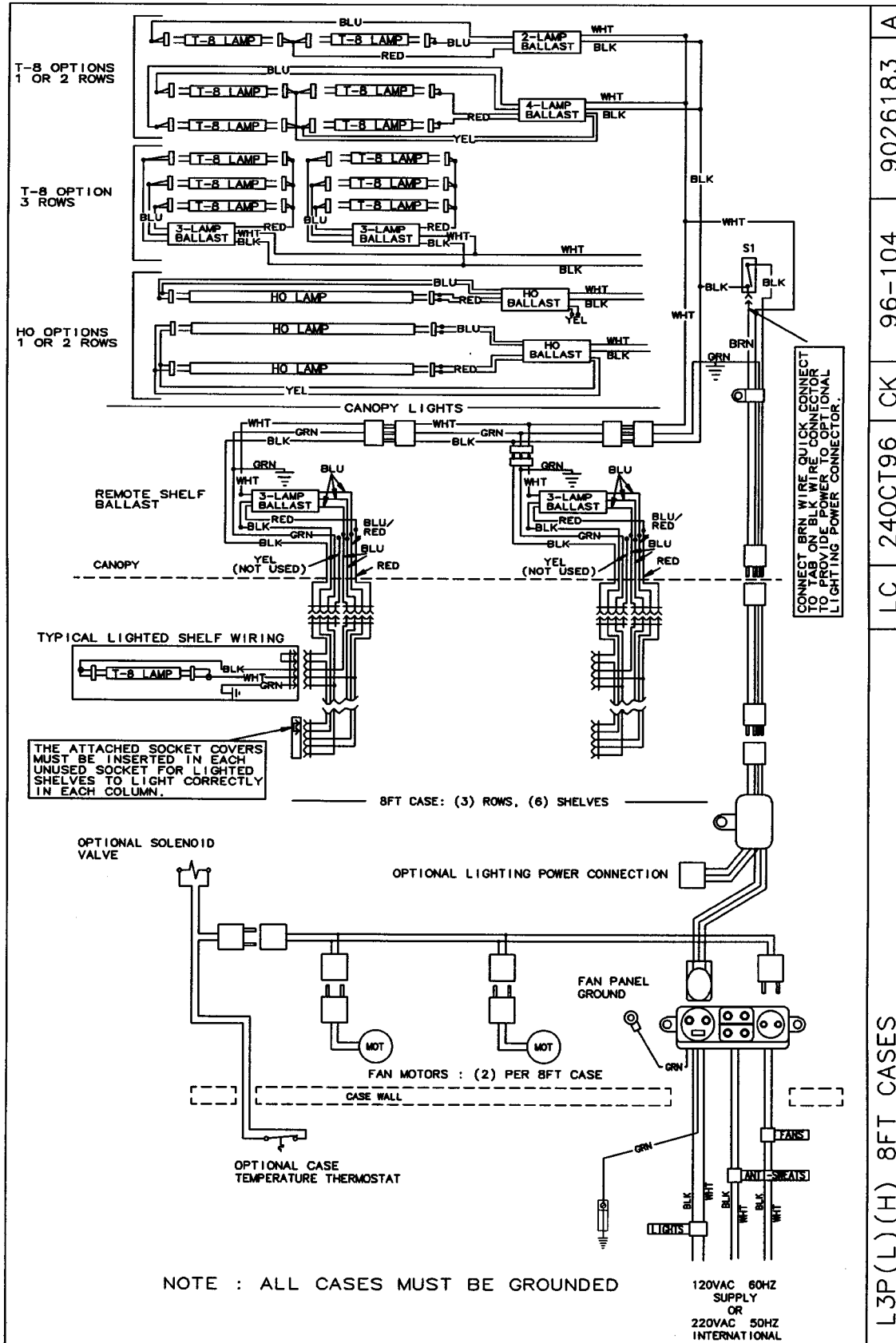

L3PL/L3PH Domestic & Export (50Hz) Case Circuits (12' Cases)

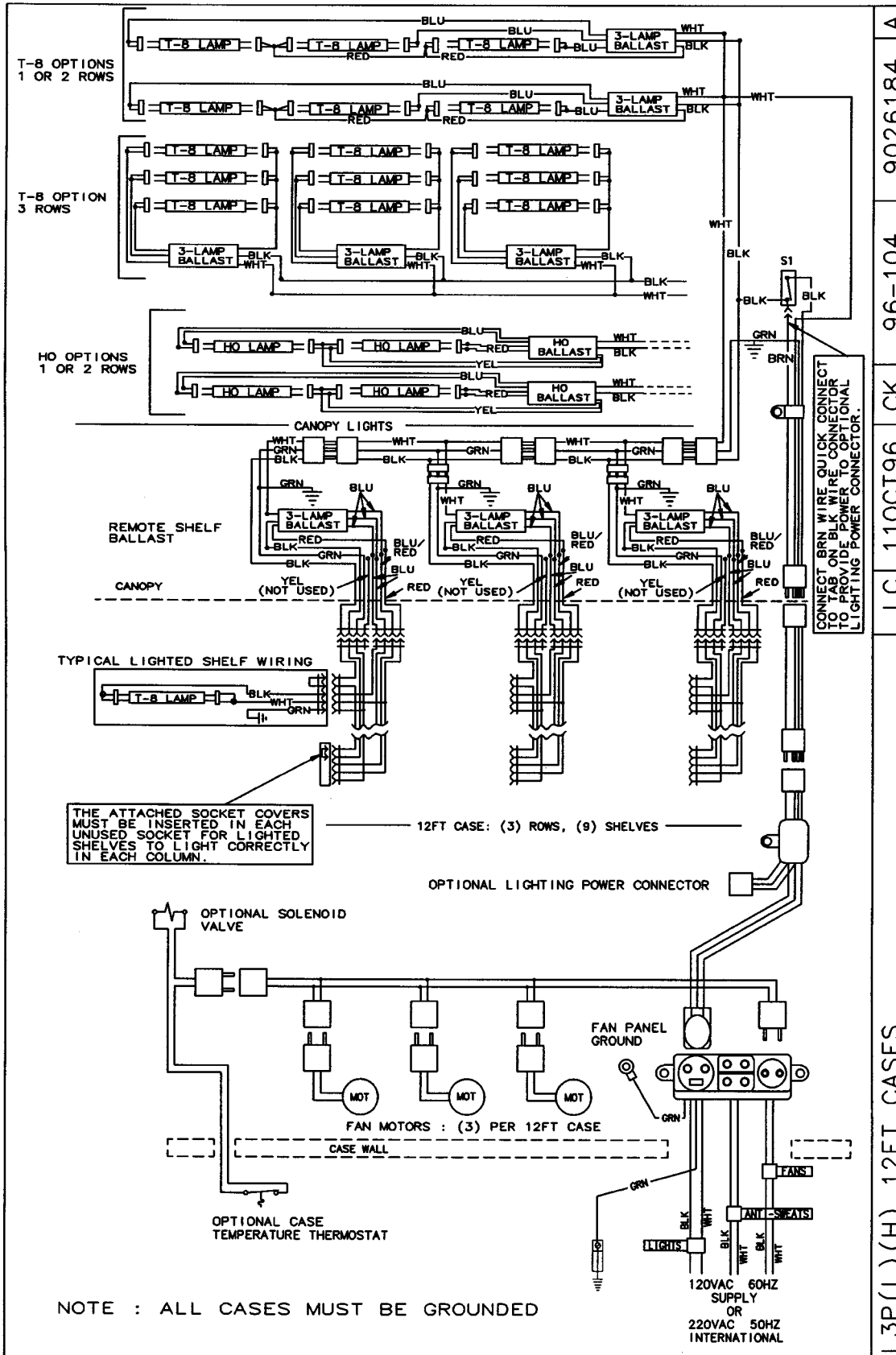

LC 110CT96 CK 96-104 9026184 A
 L3P(L)(H) 12FT CASES

Canopy Lighting Circuits (8' Cases)

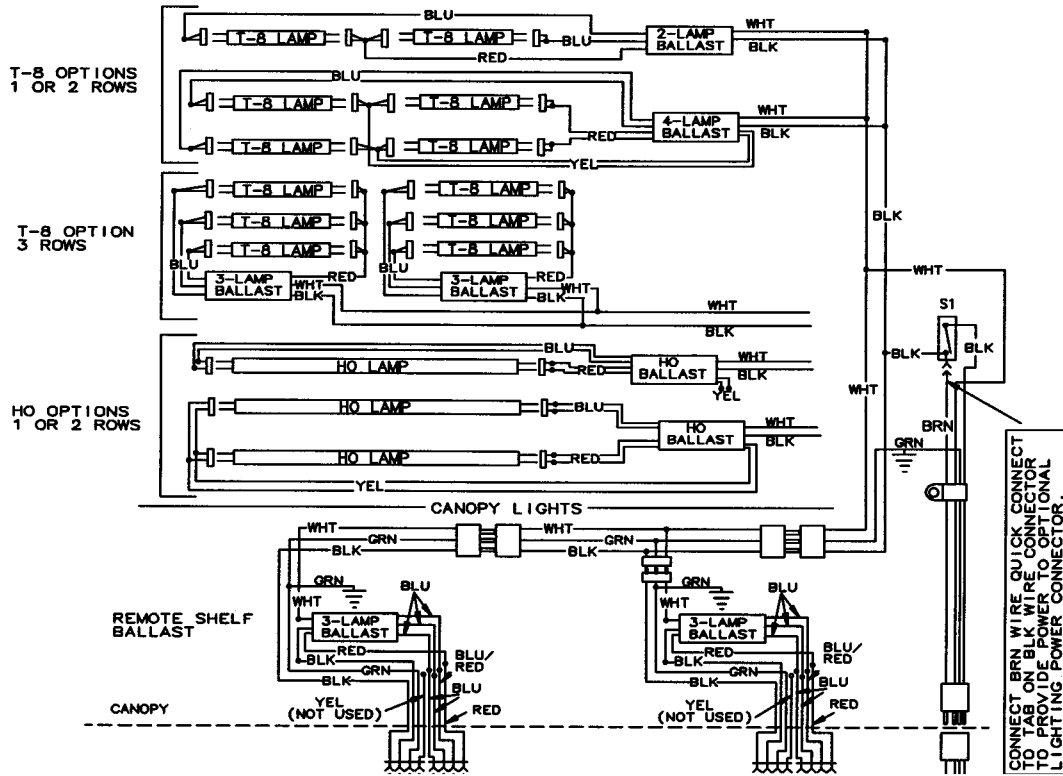

Canopy Lighting Circuits (12' Cases)

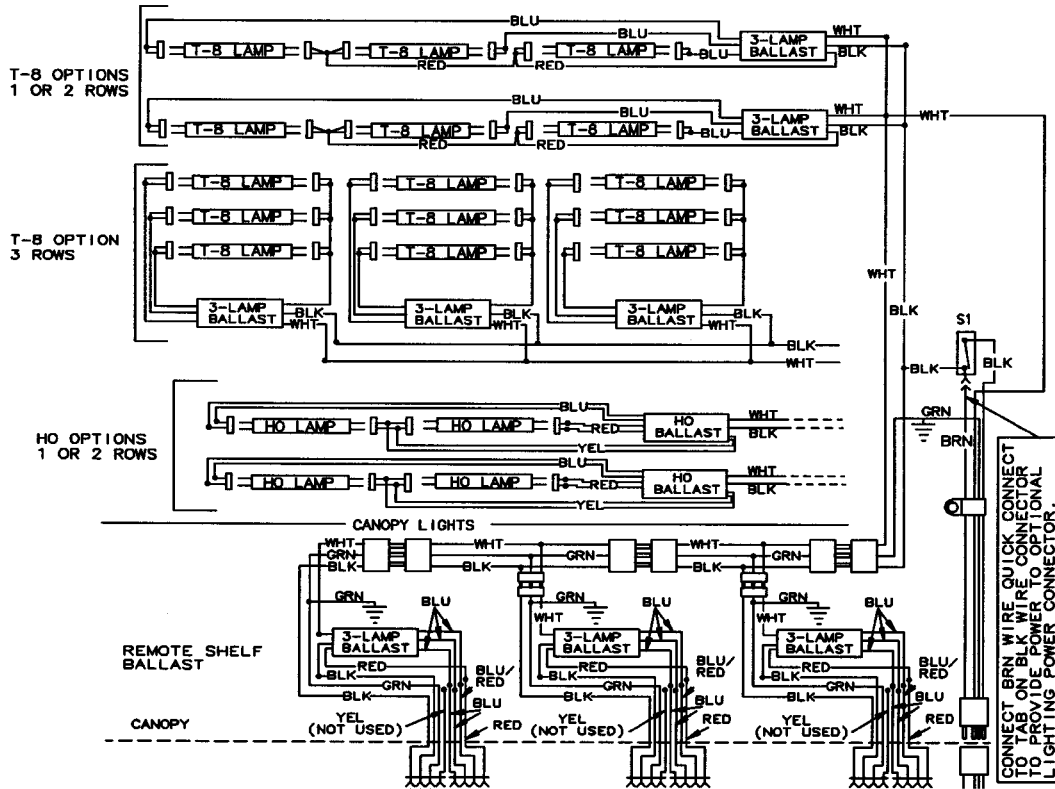

Optional Shelf Lighting Circuit (8' Cases)

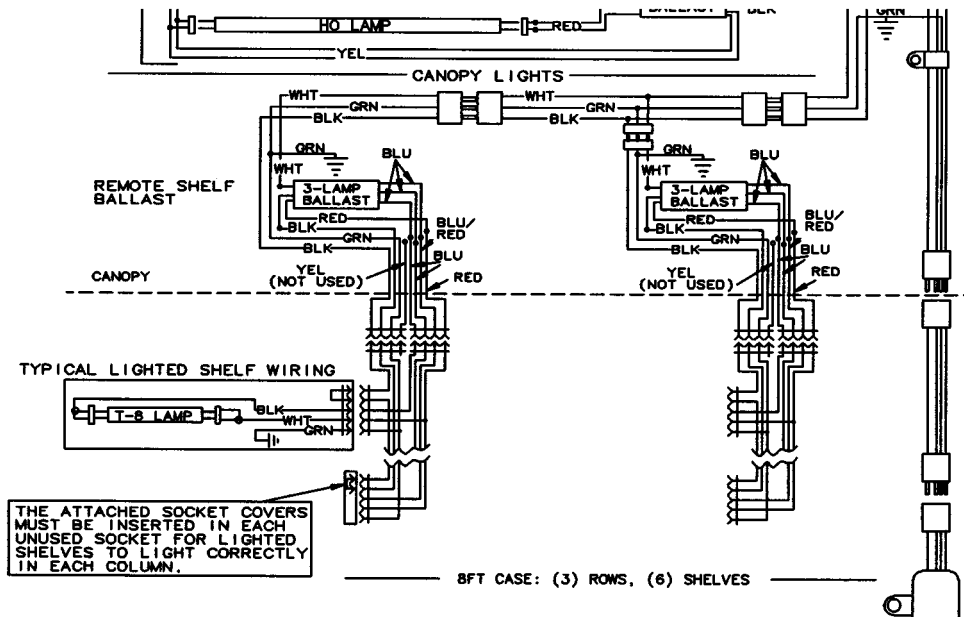

Optional Shelf Lighting Circuit (12' Cases)

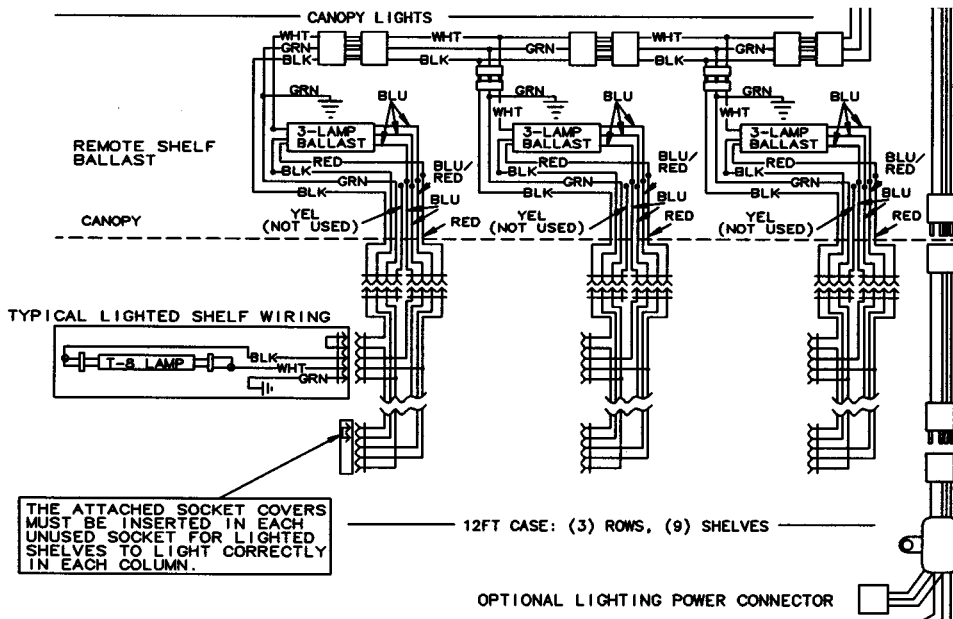

GENERAL INFORMATION

Mirror Installation

When installing mirrors you must be aware that on longer line-ups it is possible to end up with a gap at the end of the line-up. To help prevent this, leave a gap at the starting end that can be covered by the stainless steel trim. Additional mirror positioning adjustments may be required to make sure the gaps at each end of the line-up don't show when the stainless steel trim is in place. Also make sure all mirrors have a good tight seal between each mirror.

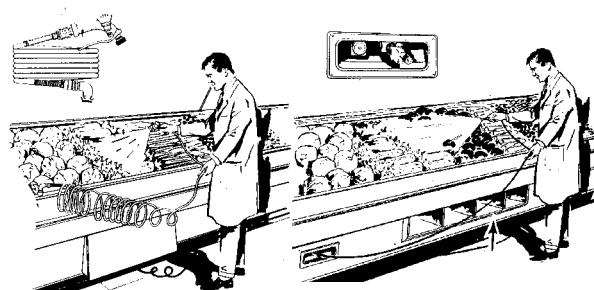

Water Spray Accessories

WARNING

When using water spray accessories it may be necessary to install approved anti-backflow devices in the water supply line. Local codes should be checked in this regard. Installation of this device is the responsibility of the end user and would be performed by plumbers.

CAUTION

Do not spray lighted shelves when using any water spray accessories. Moisture on light fixtures could cause an electrical short and/or damage the case operating system.

The water supply pressure should not exceed 45 lb to assure proper operation. Water supply pressures above 45 lb should use a pressure reducing valve.

The spring coil spray hose or retractable spray hose are the two manual systems available for produce cases. To use the retractable spray hose, pull the nozzle and hose out smoothly to the desired length. When the reel ratchet sounds, let the hose back against the ratchet to hold it in place. To rewind, pull hose out slightly to release the reel ratchet, then guide the hose back into the front of the case. Do not allow hose to rewind by itself. Hose jamming and/or reel damage could result.

Retractable Hose Replacement

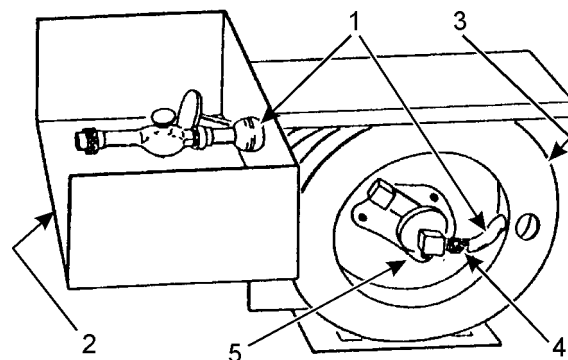

1. Pull hose (1) completely out of front of case (2) and engage reel ratchet.
2. Fasten locking pliers on the reel edge (3) to prevent the reel from accidentally rewinding. The reel spring is fully wound in this position.
3. Remove hose (1) from hose clamps on the reel (3) and disconnect hose end fitting (4) from swivel assembly (5). Remove hose (1) from reel (3) and front of case (2).

CAUTION

Do not allow the reel to unwind suddenly or attempt to turn reel clockwise. This will damage the spring motor in the reel.

NOTE

If reel spring is unwound, wind the reel 19 complete turns counterclockwise, engage the reel ratchet and install locking pliers on reel edge.

4. Insert hose (1) through the front of the case (2) and the hole in the reel (3).
5. Apply pipe dope to threads of hose end fitting (4). Install hose end fitting (4) in the swivel assembly (5).
6. Attach the hose (1) securely to the reel (3) with the hose clamps on the reel.
7. Retract the hose (1) onto the reel (3).

NOTE

If reel does not work properly after rewinding, replace the reel assembly.

Produce Handling Tips

Fresh fruits and vegetable are living things, even after they have been harvested. They continue the process of respiration and transpiration after harvesting. Respiration is the process of self feeding to provide energy for maintaining life. (EXAMPLE: Asparagus and sweet corn generate heat after they are picked.) Transpiration is the process of water loss through vapor from the plant tissues. Post-harvest life can be maintained by slowing the rate of water loss. Refrigeration lowers the rate of respiration and transpiration. Store most types of produce close to freezing prior to display. There are a number of explanations (ex. Cucumbers can be kept relatively cool by themselves, but could be damaged by temperatures below 40°F). See chart on following pages for specifics.

Non-refrigerated produce cases are called "Dry" cases. They are used to display potatoes, dry onions, bananas, avocados and other products which don't need refrigeration. These cases can also be used with a bed of cracked ice to display perishables.

Refrigerated produce cases displays produce products that require refrigeration. The refrigeration coil is below the display and fans are used to circulate air through the case display. This moving air will pick up moisture from unwrapped produce and carry it to the coil. It is necessary to replace this moisture by using a water spray several times during the day. At night the produce should be covered with a wet cloth. The alternate to sprinkling is to wrap the produce.

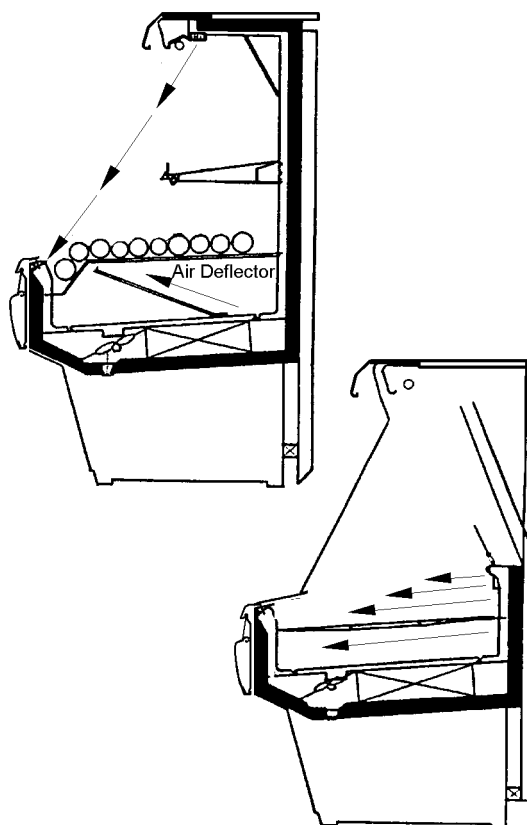

In order to maintain case air flow, the return air duct must not be blocked by product. An important aid to improve air circulation is to use air deflectors below the elevated screens in the case. These deflectors will direct the air flow into the display and prevent cool air from "short circuiting" the display. Deflectors are furnished with hump screen option. See illustration.

Produce Handling Chart

<u>Produce</u>	<u>Ideal Storage Conditions</u>			<u>Display Rack Care</u>		<u>Special Notes</u>
	<u>Temperature (°F)</u>	<u>Relative Humidity (%)</u>	<u>Sell Quickly (1-2 days)</u>	<u>Refrigerate (40°F)</u>	<u>Sprinkle with Water</u>	
Apples	30-32	85-95		Helpful	No advantage	Avoid bruising
Apricots	31-32	85-90	Yes	Helpful	No	
Asparagus	32-36	90-95	Yes	Profitable	No	Trim butts and stand in ice or shallow water
Avocados	40-55	85-90	Yes	No	No	Display on padded surface
Bananas, Ripe	56-58	85-90	Yes	No	No	Display on padded surface
For Ripening	58-68	90-95		No	No	Avoid bruising
Beans, Lima	32-40	85-90	Yes	Profitable	No	Shake up to aerate
Beans, Snap	40-45	90-95	Yes	Profitable	Yes	
Beets	32	85-95	Yes	Profitable	Yes	Moisten roots only
Berries	31-32	90-95	Yes	Helpful	No	Keep well ventilated
Broccoli	32-35	90-95	Yes	Profitable	Yes	Keep out of sun
Brussel Sprouts	32-35	90-95	Yes	Profitable	Yes	Remove yellow leaves
Cabbage	32	90-95		Helpful	Yes	
Carrots	32	90-95		Profitable	Yes	Moisten roots only of bunches
Cauliflower	32	90-95	Yes	Profitable	Yes	Sprinkle only if refrigerated
Celery	31-32	90-95	Yes	Profitable Yes		
Cherries	31-32	90-95	Yes	Helpful	No	Keep well ventilated
Corn, Sweet	31-32	90-95	Yes	Profitable	Yes	Keep cold to keep sweetness
Cucumbers	45-50	85-90	Yes	No	No advantage	
Eggplants	45-50	85-90	Yes	No	No advantage	Do not bruise, keep on ice
Grapefruit	50-60	85-90		Helpful	No advantage	Remove decayed fruit
Grapes	30-32	85-95	Yes	Helpful	No	Keep well ventilated
Honeydews	45-50	85-90		Helpful	No	Cover cut melons with transparent film
Lemons	38-40	85-90		Helpful	Yes	Sprinkling may be helpful
Lettuce	32	90-95	Yes	Profitable	Yes	Avoid soaking with water
Limes	48-50	85-90		Helpful	No advantage	
Mushrooms	32-35	80-90	Yes	Helpful	No	Handle carefully, keep dry
Muskmelons	32-35	85-90	Yes	Helpful	No	Cover cut melons with transparent film
Onions, Dry	32	65-70		No	No	Remove loose wrappers, keep dry
Onions, Green	32	90-95	Yes	Profitable	Yes	Keep well ventilated
Oranges	34-38	85-90		Helpful	No advantage	Remove decayed fruit
Parsnips	32	90-95		Helpful	Yes	Moisten roots only
Peaches, Ripe	31-32	90	Yes	Helpful	No	Ripen at room temperature before storage
Pears	29-31	90-95	Yes	Helpful	No	Display in single or double layer on pads

<u>Produce</u>	<u>Ideal Storage Conditions</u>			<u>Display Rack Care</u>		
	<u>Temperature (°F)</u>	<u>Relative Humidity (%)</u>	<u>Sell Quickly (1-2 days)</u>	<u>Refrigerate (40°F)</u>	<u>Sprinkle with Water</u>	<u>Special Notes</u>
Peas, Green	32	90-95	Yes	Profitable	Yes	Shake up to aerate, keep cold
Peppers	45-50	90-95	Yes	Profitable	Yes	
Pineapples, Ripe	45-55	85-90	Yes	No	No	Remove decayed fruit
Plums	31-32	90-95	Yes	Helpful	No	Remove decayed fruit
Potatoes	40-50	85-90		No	No	Keep out of sun
Radishes	32	90-95	Yes	Profitable	Yes	Keep water off tops, avoid tight packing
Rhubarb	32	90-95	Yes	Profitable	No	Trim thin slice off stems and stand in cold water
Squash, Summer	40-50	85-95	Yes	Helpful	Yes	
Winter & Pmpkns	50-55	50-75		No	No	
Spinach	32	90-95	Yes	Profitable	Yes	Keep ventilated
Sweet Potatoes	55-60	85-90		No	No	Keep ventilated
Tangerines	32	85-90	Yes	Profitable	Yes	Remove decayed fruit
Tomatoes, Ripe	45-50	85-90	Yes	Helpful	No	Sell quickly, refrigerate to hold
Tomatoes, Green	55-70	85-90		No	No	Ripen in back room, sort frequently
Turnips	32	90-95		Profitable	Yes	Sprinkle roots only
Watermelons	40-45	80-85		Helpful	No	Cover cut melons with transparent film

The "Produce Handling Chart" is courtesy of Produce Marketing Association, Inc., Newark, Delaware 19711, from their 1973 Yearbook. This book is published as a service to the Fresh Produce Industry.

For additional information, consult:

"The Commercial Storage of Fruits, Vegetables, and Florist and Nursery Stocks", USDA Handbook No. 66, 1968.

"The Shelf Life of Fresh Fruits and Vegetables - Retail Store Display Cases", USDA HT&S Office Report No. 247, October 1951.

"Fresh Fruits and Vegetables - Handling and Care", Corporate Extension Service, Michigan State University.

SERVICE INSTRUCTIONS

See "General I&S Manual" for T-8 lamp, and ballast, fan blade and motor, and color band and bumper replacement instructions.

Ballast and Lighting Locations

All light ballasts are located under the canopy and mounted on the top of the canopy light fixture. This includes remote ballasts for optional shelf lights. The canopy light(s) are under the canopy light fixture in the top of the case. The optional shelf lights are mounted in separate light fixtures under the front of each shelf section.

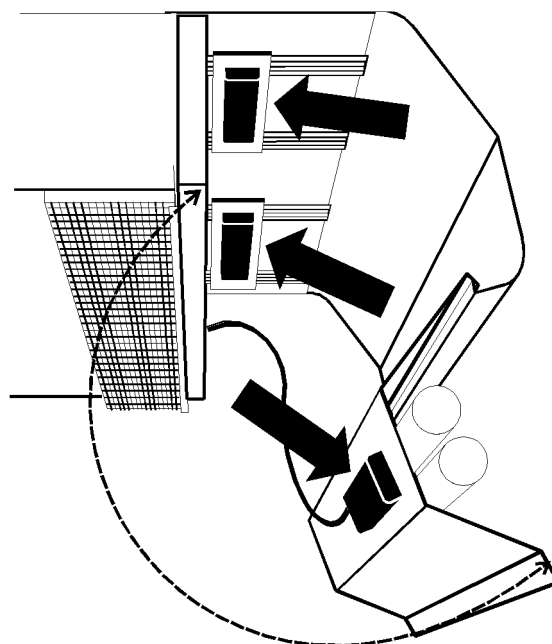

PARTS INFORMATION

Operational Parts List

Case Usage	Domestic		Export	
	8'	12'	8'	12'
Electrical Circuit	115 Volt 60 Hertz		220 Volt 50 Hertz	
Case Size	8'	12'	8'	12'
Fan Motor	5125532	5125532	5202539	5202539
	5 Watt	5 Watt	7.5 Watt	7.5 Watt
Fan Motor Brackets	5962269	5962269	5962269	5962269
Fan Blades (7" 30° 5B)	5223370	5223370	5223370	5223370
T-8 Lamp Ballast (canopy & shelf)				
(canopy)(2 lamp)	5991029	----	9028437	----
(canopy)(3 lamp)	----	5991030	----	9028438
(canopy)(4 lamp)	5966635	----	9028439	----
(opt. shelf)(3 lamp)	5991030	5991030	9028438	9028438
Opt. 800MA Lamp Ballast (canopy)	5049140	5049140	5204859	5204859
T-8 Lampholder (canopy)	5232279	5232279	5232279	5232279
T-8 Lampholder (shelf)	5092414	5092414	5092414	5092414
Opt. 800MA Lampholder (telescoping)	5614628	5614628	5614628	5614628
Opt. 800MA Lampholder (stationary)	5614629	5614629	5614629	5614629
Light Switch (SPST)	5100565	5100565	5100565	5100565

For information on operational parts not listed above contact the TYLER Service Parts Department.

Cladding and Trim Parts List

Item Description	L3PL		L3PH	
	8'	12'	8'	12'
1 Screw	5183536(4)	5183536(6)	5183536(4)	5183536(6)
2 Screw	5183536(4)	5183536(6)	5183536(4)	5183536(6)
3 Hood Close-off	9026069	9026070	9026069	9026070
4 Screw (per end cover)	5183536(4)	5183536(4)	5183536(4)	5183536(4)
5 End Cover	9026103(2)	9026103(2)	9026103(2)	9026103(2)
6 Canopy Hood, Painted	9025223	9025224	9025223	9025224
7 Canopy Hood Backer, Painted	9025983	9025983	9025983	9025983
8 Bumper Retainer / Handrail	-----	color per order	-----	-----
9 Color Band, Painted	9023798	9023800	9023798	9023800
10 Color Band Backer, Painted	9040223	9040223	9040223	9040223
11 Handrail Backer, Pntd.	9025316	9025316	9025316	9025316
12 Bumper Backer	-----	color per order	-----	-----
13 Bumper End Trim	-----	color per order	-----	-----
14 Bumper	-----	color per order	-----	-----
15 Upr. Frt. Cladding, Painted	----	----	9025479	9025480
16 Rivet	----	----	5104702(4)	5104702(6)
17 Screw, Shoulder	9025833(6)	9025833(8)	9025833(6)	9025833(8)
18 Lwr. Frt. Cladding, Painted	9025477	9025478	9025477	9025478
19 Kickplate	-----	color per order	-----	-----
20 Kickplate Backer	9041790	9041790	9041790	9041790
21 Screw	5183536(6)	5183536(8)	5183536(6)	5183536(8)
22 Kickplate Support	9041329(3)	9041329(4)	9041329(3)	9041329(4)
23 Screw	5183536(6)	5183536(8)	5183536(6)	5183536(8)
24 Raceway	9025127	9025128	9025127	9025128
25 LH End Close-off, Painted	9022459	9022459	9022459	9022459
RH End Close-off, Painted	9022466	9022466	9022466	9022466
26 Horizontal Joint Trim	9025959	9025959	9025959	9025959

