



TECHNICAL SERVICE MANUAL

JACKETED ASPHALT PUMPS
 SERIES 34 AND 434
 SIZES HL, KK, LQ, Q, M, N

SECTION	TSM 430
PAGE	1 OF 9
ISSUE	F

CONTENTS

Introduction	1
Special Information	1
Safety Information.	2
Maintenance	3
Disassembly	6
Assembly	7
Valve Instructions	8

INTRODUCTION

The illustrations used in this manual are for identification purposes only and should not be used for ordering parts. Secure a parts list from the factory or a Viking representative. Always give complete name of part, part number and material with the model and serial number of the pump when ordering repair parts.

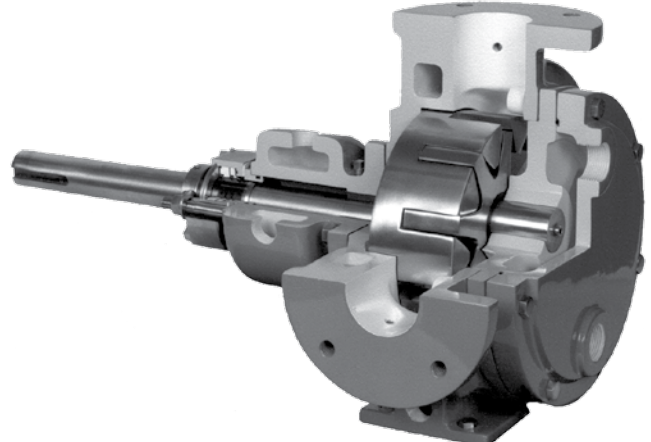

FIGURE 2
 CUTAWAY VIEW OF SERIES 434
 JACKETED PUMP

UNMOUNTED PUMP		UNITS
PACKED	MECH. SEAL	
HL34	HL434	Units are designated by the unmounted pump model numbers followed by a letter indicating drive style. V = V-belt
KK34	KK434	
LQ34	LQ434	
Q34	Q434	
M34	M434	
N34	N434	

This manual deals exclusively with series 34 and 434 Jacketed General Purpose Pumps. Refer to Figures 1 through 11 for general configuration and nomenclature used in this manual.

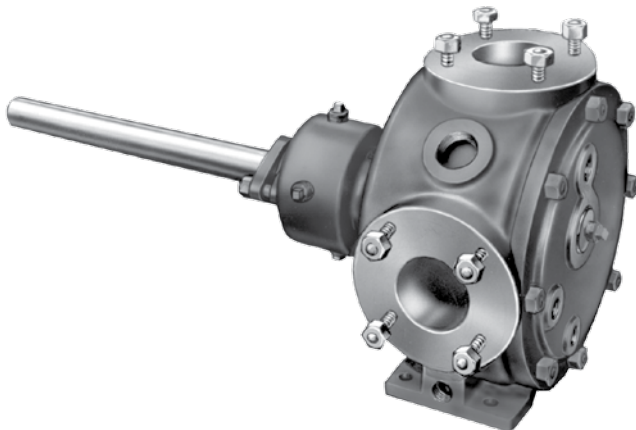

FIGURE 1
 ILLUSTRATION OF SERIES 34
 JACKETED PUMP

SPECIAL INFORMATION

DANGER !

Before opening any Viking pump liquid chamber (pumping chamber, reservoir, relief valve adjusting cap fitting, etc.) Be sure:

1. That any pressure in the chamber has been completely vented through the suction or discharge lines or other appropriate openings or connections.
2. That the driving means (motor, turbine, engine, etc.) has been "locked out" or made non-operational so that it cannot be started while work is being done on pump.
3. That you know what liquid the pump has been handling and the precautions necessary to safely handle the liquid. Obtain a material safety data sheet (MSDS) for the liquid to be sure these precautions are understood.

Failure to follow above listed precautionary measures may result in serious injury or death.

SAFETY INFORMATION AND INSTRUCTIONS

IMPROPER INSTALLATION, OPERATION OR MAINTENANCE OF PUMP MAY CAUSE SERIOUS INJURY OR DEATH AND/OR RESULT IN DAMAGE TO PUMP AND/OR OTHER EQUIPMENT. VIKING'S WARRANTY DOES NOT COVER FAILURE DUE TO IMPROPER INSTALLATION, OPERATION OR MAINTENANCE.

THIS INFORMATION MUST BE FULLY READ BEFORE BEGINNING INSTALLATION, OPERATION OR MAINTENANCE OF PUMP AND MUST BE KEPT WITH PUMP. PUMP MUST BE INSTALLED, OPERATED AND MAINTAINED ONLY BY SUITABLY TRAINED AND QUALIFIED PERSONS.

THE FOLLOWING SAFETY INSTRUCTIONS MUST BE FOLLOWED AND ADHERED TO AT ALL TIMES.

Symbol Legend :



Danger - Failure to follow the indicated instruction may result in serious injury or death.

WARNING

Warning - In addition to possible serious injury or death, failure to follow the indicated instruction may cause damage to pump and/or other equipment.



BEFORE opening any liquid chamber (pumping chamber, reservoir, relief valve adjusting cap fitting, etc.) be sure that :

- Any pressure in the chamber has been completely vented through the suction or discharge lines or other appropriate openings or connections.
- The pump drive system means (motor, turbine, engine, etc.) has been "locked out" or otherwise been made non-operational so that it cannot be started while work is being done on the pump.
- You know what material the pump has been handling, have obtained a material safety data sheet (MSDS) for the material, and understand and follow all precautions appropriate for the safe handling of the material.

WARNING

INSTALL pressure gauges/sensors next to the pump suction and discharge connections to monitor pressures.



WARNING

USE extreme caution when lifting the pump. Suitable lifting devices should be used when appropriate. Lifting eyes installed on the pump must be used **only** to lift the pump, **not** the pump with drive and/or base plate. If the pump is mounted on a base plate, the base plate must be used for all lifting purposes. If slings are used for lifting, they must be safely and securely attached. For weight of the pump alone (which does not include the drive and/or base plate) refer to the Viking Pump product catalog.



BEFORE operating the pump, be sure all drive guards are in place.



DO NOT attempt to dismantle a pressure relief valve that has not had the spring pressure relieved or is mounted on a pump that is operating.



DO NOT operate pump if the suction or discharge piping is not connected.



AVOID contact with hot areas of the pump and/or drive. Certain operating conditions, temperature control devices (jackets, heat-tracing, etc.), improper installation, improper operation, and improper maintenance can all cause high temperatures on the pump and/or drive.



DO NOT place fingers into the pumping chamber or its connection ports or into any part of the drive train if there is **any possibility** of the pump shafts being rotated.



WARNING

THE PUMP must be provided with pressure protection. This may be provided through a relief valve mounted directly on the pump, an in-line pressure relief valve, a torque limiting device, or a rupture disk. If pump rotation may be reversed during operation, pressure protection must be provided on **both** sides of pump. Relief valve adjusting screw caps must always point towards suction side of the pump. If pump rotation is reversed, position of the relief valve must be changed. Pressure relief valves cannot be used to control pump flow or regulate discharge pressure. For additional information, refer to Viking Pump's Technical Service Manual TSM 000 and Engineering Service Bulletin ESB-31.

WARNING

DO NOT exceed the pumps rated pressure, speed, and temperature, or change the system/duty parameters from those the pump was originally supplied, without confirming its suitability for the new service.



WARNING

BEFORE operating the pump, be sure that:

- It is clean and free from debris
- all valves in the suction and discharge pipelines are fully opened.
- All piping connected to the pump is fully supported and correctly aligned with the pump.
- Pump rotation is correct for the desired direction of flow.



WARNING

THE PUMP must be installed in a matter that allows safe access for routine maintenance and for inspection during operation to check for leakage and monitor pump operation.

ROTATION: Viking pumps operate equally well in a clockwise or counter clockwise rotation. Shaft rotation determines which port is suction and which is discharge. Port in area where pumping elements (gear teeth) come out of mesh is suction port.

PRESSURE RELIEF VALVES:

1. Viking pumps are positive placement pumps and must be provided with some sort of pressure protection. This may be a relief valve mounted directly on the pump, an in-line pressure relief valve, a torque limiting device or a rupture disk.
2. There are relief valve options available on these pumps. Options may include a plain or a jacketed relief valve depending on the pump size. Pumps equipped with a jacketed head plate are generally not available with a relief valve.
3. If pump rotation is to be reversed during operation, pressure protection must be provided on both sides of pump.
4. Relief valve adjusting screw cap must always point towards suction side of pump. If pump rotation is reversed, remove pressure relief valve and turn end for end.
5. Pressure relief valves cannot be used to control pump flow or regulate discharge pressure.

For additional information on pressure relief valves, Refer to Technical Service Manual TSM000 and Engineering Service Bulletin ESB-31.

MAINTENANCE

Series 34 and 434 jacketed pumps are designed for long, trouble-free service life under a wide variety of application conditions with a minimum of maintenance, however, the following should be considered.

1. **LUBRICATION:** External lubrication must be applied slowly with a handgun to all lubrication fittings every 500 hours of operation with multi-purpose grease, NLGI # 2. Do not over-grease. Applications involving very high or

low temperatures will require other types of lubrication. Refer to Engineering Service Bulletin ESB-515. Consult factory with specific lubrication questions.

2. **PACKING ADJUSTMENT:** New packed pumps generally require some initial packing adjustment to control leakage as packing “runs-in”. Make initial packing adjustments carefully and do not over-tighten the packing gland. After initial adjustment occasional inspection will reveal the need for packing gland adjustment and/or replacement of the packing. See instructions in disassembly and reassembly regarding re-packing the pump.
3. **END CLEARANCE ADJUSTMENT:** After long term operation it is sometimes possible to improve the performance of the pump, without major repair, through adjustment of end clearance of the pump. **Refer to instructions under Step 3 of Assembly, page 7.**
4. **CLEANING PUMP:** It is good practice to keep the pump as clean as possible. This will facilitate inspection, adjustment and repair work and help prevent omission of lubrication to fittings covered or hidden with dirt.
5. **STORAGE:** If pump is to be stored, or not used for any appreciable length of time it should be drained and a light coat of lubricating and preservative oil should be applied to the internal parts. Lubricate all fittings. Be sure to drain all steam jacket chambers to prevent freezing during cold weather. Tighten all assembly bolts before the pump is put into service after being stored.

SUGGESTED REPAIR TOOLS: The following tools must be available to properly repair Series 34 and 434 pumps. These tools are in addition to standard mechanics’ tools such as open end wrenches, pliers, screwdrivers etc. Most of the items can be obtained from an industrial supply house.

1. Soft Headed Hammer
2. Packing hooks, flexible (packed pumps)
Large for 0.375 inch and up cross section packing
3. Arbor Press
4. Allen wrenches (for mechanical seals)
5. Feeler gage set (for mechanical seals)

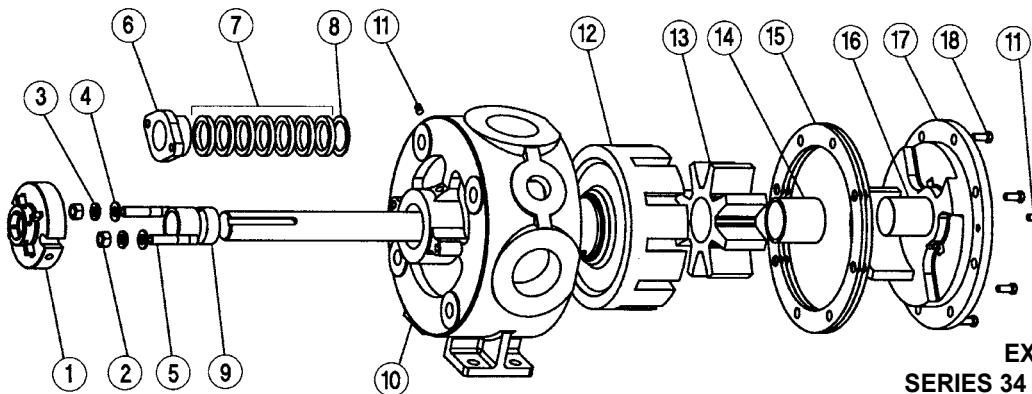

**FIGURE 3
EXPLODED VIEW
SERIES 34 & 434 PUMPS (HL SIZE)**

ITEM	NAME OF PART	ITEM	NAME OF PART	ITEM	NAME OF PART
1	Mechanical Seal	8	Packing Retainer Washer	15	Head Gasket Set
2	Nut	9	Casing Bushing	16	Idler Pin
3	Lockwasher	10	Casing (Jacketed)	17	Head (Jacketed) and Idler Pin Assembly
4	Flat Washer	11	Pipe Plug	18	Capscrew
5	Stud	12	Rotor and Shaft Assembly	Not Illus.	Relief Valve
6	Packing Gland	13	Idler and Bushing Assembly	Not Illus.	Relief Valve Gasket
7	Packing	14	Idler Bushing	Not Illus.	Relief Valve Capscrews

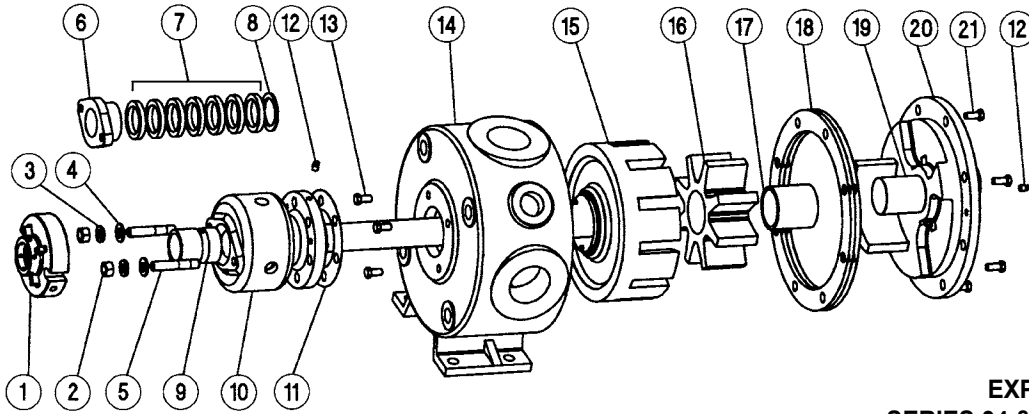

**FIGURE 4
EXPLODED VIEW
SERIES 34 & 434 PUMPS (KK SIZE)**

ITEM	NAME OF PART	ITEM	NAME OF PART	ITEM	NAME OF PART
1	Mechanical Seal	9	Rotor Bearing Sleeve Bushing	17	Idler Bushing
2	Nut	10	Rotor Bearing Sleeve	18	Head Gasket Set
3	Lockwasher	11	Gasket	19	Idler Pin
4	Flat Washer	12	Pipe Plug	20	Head (Jacketed) and Idler Pin Assembly
5	Stud	13	Capscrew	21	Capscrew
6	Packing Gland	14	Casing (Jacketed)	Not Illus.	Relief Valve
7	Packing	15	Rotor and Shaft Assembly	Not Illus.	Relief Valve Gasket
8	Packing Retainer Washer	16	Idler and Bushing Assembly	Not Illus.	Relief Valve Capscrews

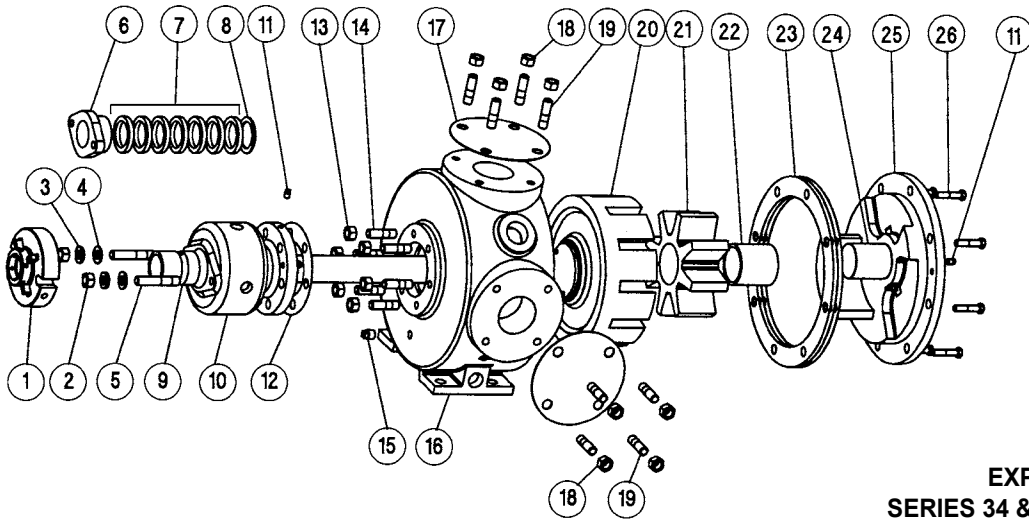

**FIGURE 5
EXPLODED VIEW
SERIES 34 & 434 PUMPS (LQ SIZE)**

ITEM	NAME OF PART	ITEM	NAME OF PART	ITEM	NAME OF PART
1	Mechanical Seal	11	Pipe Plug	21	Idler and Bushing Assembly
2	Nut	12	Gasket	22	Idler Bushing
3	Lockwasher	13	Nut	23	Head Gasket Set
4	Flat Washer	14	Stud	24	Idler Pin
5	Stud	15	Pipe Plug	25	Head (Jacketed) and Idler Pin Assembly
6	Packing Gland	16	Casing (Jacketed)	26	Capscrew
7	Packing	17	Gasket	Not Illus.	Relief Valve
8	Packing Retainer Washer	18	Nut	Not Illus.	Relief Valve Gasket
9	Rotor Bearing Sleeve Bushing	19	Stud	Not Illus.	Relief Valve Capscrews
10	Rotor Bearing Sleeve	20	Rotor and Shaft Assembly		

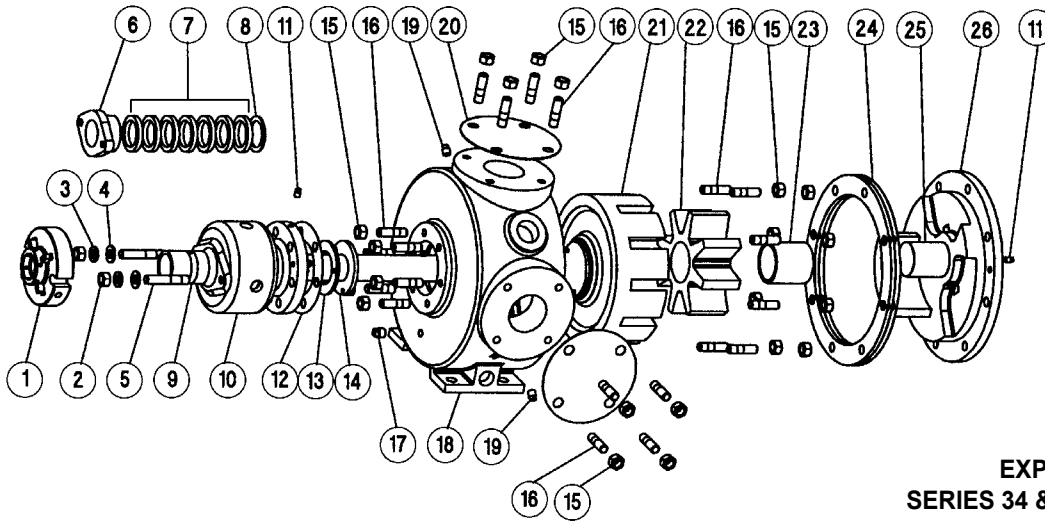

**FIGURE 6
EXPLODED VIEW
SERIES 34 & 434 PUMPS (Q SIZE)**

ITEM	NAME OF PART	ITEM	NAME OF PART	ITEM	NAME OF PART
1	Mechanical Seal	11	Pipe Plug	21	Rotor and Shaft Assembly
2	Nut	12	Gasket	22	Idler and Bushing Assembly
3	Lockwasher	13	Thrust Washer, Rotor Bearing Sleeve	23	Idler Bushing
4	Flat Washer	14	Thrust Washer, Rotor	24	Head Gasket Set
5	Stud	15	Nut	25	Idler Pin
6	Packing Gland	16	Stud	26	Head (Jacketed) and Idler Pin Assembly
7	Packing	17	Pipe Plug	Not Illus.	Relief Valve
8	Packing Retainer Washer	18	Casing (Jacketed)	Not Illus.	Relief Valve Gasket
9	Rotor Bearing Sleeve Bushing	19	Pipe Plug	Not Illus.	Relief Valve Capscrews
10	Rotor Bearing Sleeve	20	Gasket		

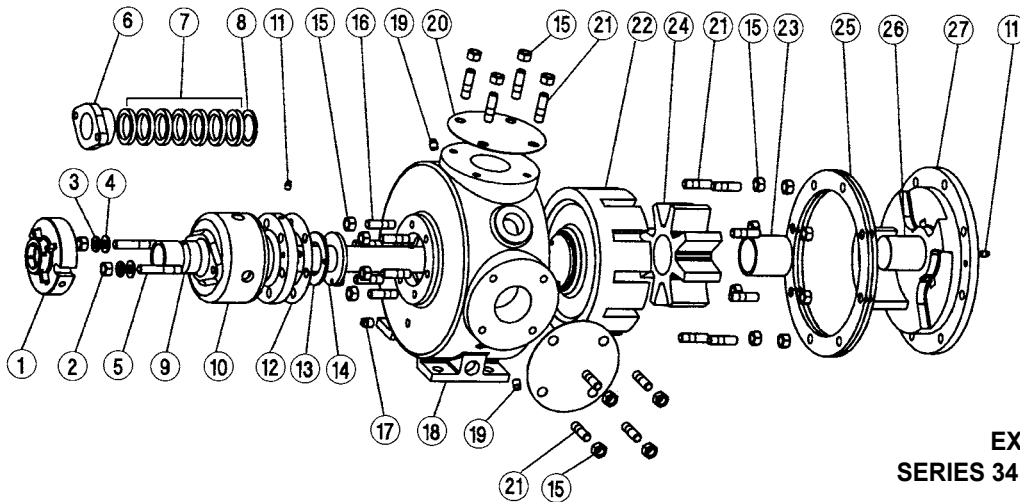

**FIGURE 7
EXPLODED VIEW
SERIES 34 & 434 PUMPS (M SIZE)**

ITEM	NAME OF PART	ITEM	NAME OF PART	ITEM	NAME OF PART
1	Mechanical Seal	11	Pipe Plug	21	Head Gasket Set
2	Nut	12	Gasket	22	Rotor and Shaft Assembly
3	Lockwasher	13	Thrust Washer, Rotor Bearing Sleeve	23	Idler Bushing
4	Flat Washer	14	Thrust Washer, Rotor	24	Idler and Bushing Assembly
5	Stud	15	Nut	25	Head Gasket Set
6	Packing Gland	16	Stud	26	Idler Pin
7	Packing	17	Pipe Plug	27	Head (Jacketed) and Idler Pin Assembly
8	Packing Retainer Washer	18	Casing (Jacketed)	Not Illus.	Relief Valve
9	Rotor Bearing Sleeve Bushing	19	Pipe Plug	Not Illus.	Relief Valve Gasket
10	Rotor Bearing Sleeve	20	Gasket	Not Illus.	Relief Valve Capscrews

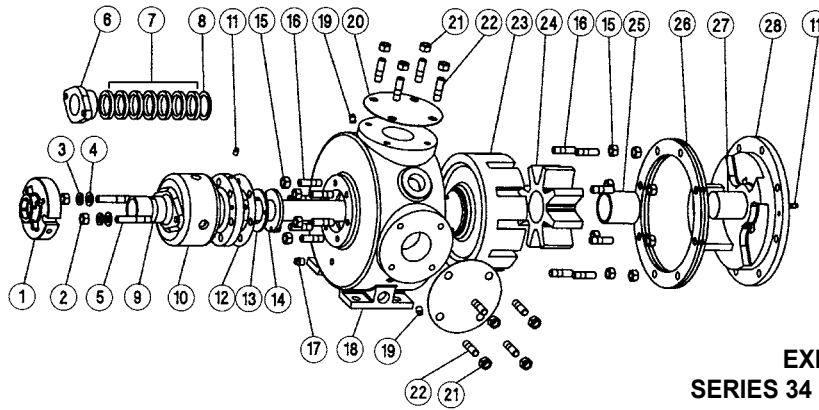

**FIGURE 8
EXPLODED VIEW
SERIES 34 & 434 PUMPS (N SIZE)**

ITEM	NAME OF PART	ITEM	NAME OF PART	ITEM	NAME OF PART
1	Mechanical Seal	12	Gasket	23	Rotor and Shaft Assembly
2	Nut	13	Thrust Washer, Rotor Bearing Sleeve	24	Idler and Bushing Assembly
3	Lockwasher	14	Thrust Washer, Rotor	25	Idler Bushing
4	Flat Washer	15	Nut	26	Head Gasket Set
5	Stud	16	Stud	27	Idler Pin
6	Packing Gland	17	Pipe Plug	28	Head (Jacketed) and Idler Pin Assembly
7	Packing	18	Casing (Jacketed)	Not Illus.	Relief Valve
8	Packing Retainer Washer	19	Pipe Plug	Not Illus.	Relief Valve Gasket
9	Rotor Bearing Sleeve Bushing	20	Gasket	Not Illus.	Relief Valve Capscrews
10	Rotor Bearing Sleeve	21	Nut		
11	Pipe Plug	22	Stud		

DISASSEMBLY

DANGER !

Before opening any Viking pump liquid chamber (pumping chamber, reservoir, relief valve adjusting cap fitting, etc.) Be sure:

1. That any pressure in the chamber has been completely vented through the suction or discharge lines or other appropriate openings or connections.
2. That the driving means (motor, turbine, engine, etc.) has been "locked out" or made non-operational so that it cannot be started while work is being done on pump.
3. That you know what liquid the pump has been handling and the precautions necessary to safely handle the liquid. Obtain a material safety data sheet (MSDS) for the liquid to be sure these precautions are understood.

Failure to follow above listed precautionary measures may result in serious injury or death.

NOTE: Mark the head and casing before disassembly to insure proper reassembly. The idler pin, which is offset in pump head, should be properly positioned toward and equal

distance between the port connections to allow for proper flow of liquid through the pump.

1. Allow pump to cool. Remove the head from the pump. If pump is furnished with a relief valve it need not be removed from head or disassembled at this point.
2. For mechanical seal pumps, remove any flush lines going to the mechanical seal if this has not already been done.

CAUTION !

Do not allow the idler to fall from the idler pin. Tilting the head up as it is removed will prevent this occurrence. Avoid damaging the head gasket if possible.

3. For pumps with X-100 or X-200 mechanical seals, insert the setting clips back in place. For pumps with PSII® seals, rotate the installation tabs 90 degrees so they contact the sleeve. Loosen the set screws that secure the seal sleeve to the shaft.
4. Remove the nuts, washers and lockwashers holding the mechanical seal and slide the seal assembly from the shaft.
5. Carefully remove rotor and shaft from the pump.

CAUTION !

Avoid damaging the rotor bearing sleeve bushing.

6. **THRUST WASHERS:** Rotor thrust washer and rotor bearing sleeve thrust washer – used in Q, M and N size pumps should be removed, examined for excessive wear and replaced if necessary. These thrust washers are located on the hub of the rotor and the casing end of rotor bearing sleeve.
7. If the rotor-bearing sleeve, casing or idler bushing shows signs of wear it should be replaced. All parts should be checked for wear before the pump is put together. When making major repairs, such as replacing a rotor and shaft, it is usually considered advisable to also install a new head and idler. When making minor repairs, where only an idler bushing and idler pin are required, other new parts are usually not necessary. When all the necessary parts are available, the pump can be assembled.

ASSEMBLY

1. Thrust washers used in Q, M and N size pumps should be assembled on the rotor hub and rotor-bearing sleeve. Put the plain washer on the two locating pins on the rotor hub. Put the grooved face washer on the pins on the rotor-bearing sleeve with the grooved face toward the rotor.
2. Remove all burrs and rough surfaces from the rotor and shaft and assemble in the casing. Lubricate the rotor shaft and bushing with grease and start the shaft through the rotor bearing sleeve or casing bushing. Slowly turn the rotor and push it into the casing as far as it will go.
3. Place the head gaskets on the head. The proper amount of gaskets should be used to provide the necessary end clearance within the pump so it turns freely with no appreciable endplay. The Gasket Table (**below**) gives the normal amount of gaskets used on each pump.

PUMP MODELS	NORMAL AMOUNT USED (INCH)	ONE SET OF GASKETS CONSISTS OF THE FOLLOWING
HL 34 & 434	.010" - .020"	1 - .005" , 2 - .007"
KK 34 & 434	.015" - .025"	2 - .007" , 1 - .015"
LQ 34 & 434	.025" - .035"	1 - .015" , 2 - .006"
Q, M, N 34 & 434	.020" - .035"	2 - .015" , 1 - .006"

**FIGURE 9
GASKET TABLE**

4. Lubricate the idler pin with lube oil and place the idler and bushing assembly on the idler pin.
5. The head can now be assembled on the pump. Make sure it is installed in the correct position **See Disassembly Step 1 (Note), page 6**. Tilt the top of the head away from the pump slightly until the crescent enters the inside diameter of the rotor and rotate the idler until its teeth mesh with the rotor teeth. Do not damage the head gaskets. Tighten the head capscrews or nuts and then check the end clearance. If the pump shaft cannot be rotated, more gaskets must be added. If, however, the pump has any noticeable end play, remove enough gaskets so the pump has no appreciable end play but still turns freely.

PACKED PUMPS

6. Pack the pump. It is good practice to install a set of new packing. The pump should be packed with packing suitable for the liquid being pumped.

Cut the packing into individual rings that wrap exactly around the shaft. Install and seat each ring one at a time, staggering the ring joints from one side of the shaft to the other. Lubricate the packing rings with oil, grease or graphite to aid in assembly. A length of pipe or tubing will help in seating the packing rings.

7. Install the packing gland and nuts. The gland must enter the stuffing box at least one-eighth of an inch after tightening the packing gland nuts. Be sure the packing does not wedge between the stuffing box and the gland, as this may split the stuffing box.

MECHANICAL SEAL PUMPS

(X-100 & X-200)

6. Make sure the shaft is clean and free of any nicks or burrs. Lubricate the shaft with lube oil and slide the mechanical seal in place.
7. Place flat washers and lock washers on the studs then thread on the retaining nuts. Tighten the nuts evenly to secure the mechanical seal to the stuffing box face. Make sure the seal setting clips are in place and tighten the drive setscrews to the shaft. Leave the setting clips in place until after the pump is installed on the drive unit. Be sure and remove the clips before start up.

(PSII SEAL®)

6. Make sure the shaft is clean and free of any nicks or burrs. Lubricate the shaft with lube oil and slide the mechanical seal in place.
7. Rotate the seal installation tabs 90 degrees so they point towards the seal sleeve. Adjust the position of the seal so the sleeve is evenly spaced between the tabs. Place flat washers and lock washers on the studs then thread on the retaining nuts. Tighten the nuts evenly to secure the seal to the stuffing box face. Tighten the drive setscrews to the shaft. Using a feeler gage, make sure there is still an equal space between the sleeve and the retaining tabs. Readjust if necessary. Leave the seal installation tabs in position until the pump is installed on the drive unit and properly aligned. Rotate the tabs 90 degrees before pump start up.

MECHANICAL SEAL NOTES

1. Vent air from stuffing box before start up. The seal may fail prematurely if this is not done.
2. Preheat seal prior to introducing hot product.
3. Use of low pressure (2 – 4 psi) continuous flow steam quench on the atmospheric side is recommended. Failure to use a steam quench could result in premature seal failure.
4. For double seals, pressurize seal chamber before startup.
5. Do not start pump until it is fully heated. Mechanical seal will fail almost instantly if hard product is in the seal chamber.
6. Do not use the PSII® cartridge lip seal for filled asphalt or any product containing abrasives.

7. When converting an existing installation to a mechanical seal, special attention must be placed on the condition of the pump. All pumps should be inspected to make sure the rotor shaft is in good condition. Any shaft wear due to packing will result in mechanical seal leakage. In general, the rotor and shaft assembly should be replaced. N size pumps can use the same rotor bearing sleeve assembly without modification. Outboard face of this assembly will need to be cleaned to make sure there is a good surface for the mechanical seal to seal against.
8. Most asphalt pumps are V-Belt driven. Packing is quite tolerant of any misalignment but mechanical seals are not. Make sure sheaves are aligned properly (see TSM 000) and that the rotor shaft is properly supported with a pillow block bearing. It is also important to make sure the mechanical seal is properly aligned with the rotor shaft. This is done at the time of seal installation. Be sure to recheck alignment when the rotor shaft is inserted in the pillow block bearing.

PRESSURE RELIEF VALVE INSTRUCTIONS

Series 34 and 434 jacketed pumps may be furnished with a relief valve head and a plain or jacketed relief valve as illustrated in Figures 10 and 11.

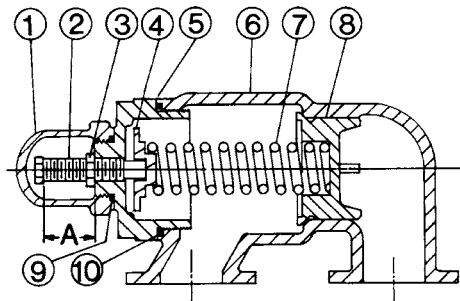

FIGURE 11
PLAIN VALVE

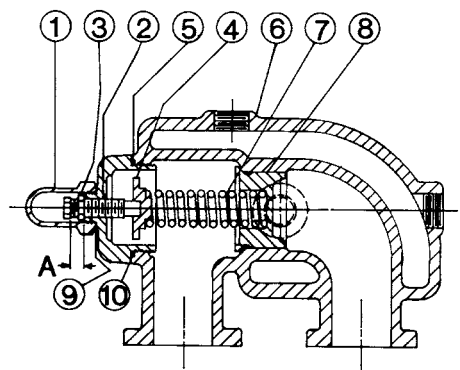

FIGURE 11
JACKETED VALVE

VALVE - LIST OF PARTS

1. Valve Cap	6. Valve Body
2. Adjusting Screw	7. Valve Spring
3. Lock Nut	8. Poppet
4. Spring Guide	9. Cap Gasket
5. Bonnet	10. Bonnet Gasket

DISASSEMBLY

DANGER !

Before opening any Viking pump liquid chamber (pumping chamber, reservoir, relief valve adjusting cap fitting, etc.) Be sure:

1. That any pressure in the chamber has been completely vented through the suction or discharge lines or other appropriate openings or connections.
2. That the driving means (motor, turbine, engine, etc.) has been "locked out" or made non-operational so that it cannot be started while work is being done on pump.
3. That you know what liquid the pump has been handling and the precautions necessary to safely handle the liquid. Obtain a material safety data sheet (MSDS) for the liquid to be sure these precautions are understood.

Failure to follow above listed precautionary measures may result in serious injury or death.

ASSEMBLY

Follow the procedure outlined under Disassembly in reverse order.

If valve is removed for repairs, be sure to replace in same position. The valve cap should point towards the suction port.

CAUTION !

Before starting the pump, be sure all drive equipment guards are in place.

Failure to properly mount guards may result in serious injury or death.

IMPORTANT

In ordering parts for relief valve on head, always be sure to give Model and Serial Number of pump as it appears on nameplate and the name of the part wanted. When ordering springs, be sure to give the pressure setting desired.

**VIKING
PUMP**

TECHNICAL SERVICE MANUAL

JACKETED ASPHALT PUMPS

SERIES 34 AND 434

SIZES HL, KK, LQ, Q, M, N

SECTION	TSM 430
PAGE	9 OF 9
ISSUE	F

**VIKING
PUMP**

IDEX
CORPORATION

WARRANTY

Viking warrants all products manufactured by it to be free from defects in workmanship or material for a period of one (1) year from date of startup, provided that in no event shall this warranty extend more than eighteen (18) months from the date of shipment from Viking. The warranty period for Universal Seal series pumps ONLY (Universal Seal models listed below) is three (3) years from date of startup, provided that in no event shall this warranty extend more than forty-two (42) months from the date of shipment from Viking.

UNDER NO CIRCUMSTANCES SHALL VIKING BE LIABLE UNDER THIS WARRANTY OR OTHERWISE FOR SPECIAL, INCIDENTAL, INDIRECT, CONSEQUENTIAL OR PUNITIVE DAMAGES OF ANY KIND, INCLUDING, BUT NOT LIMITED TO, LOST OR UNREALIZED SALES, REVENUES, PROFITS, INCOME, COST SAVINGS OR BUSINESS, LOST OR UNREALIZED CONTRACTS, LOSS OF GOODWILL, DAMAGE TO REPUTATION, LOSS OF PROPERTY, LOSS OF INFORMATION OR DATA, LOSS OF PRODUCTION, DOWNTIME, OR INCREASED COSTS, IN CONNECTION WITH ANY PRODUCT, EVEN IF VIKING HAS BEEN ADVISED OR PLACED ON NOTICE OF THE POSSIBILITY OF SUCH DAMAGES AND NOTWITHSTANDING THE FAILURE OF ANY ESSENTIAL PURPOSE OF ANY PRODUCT.

THIS WARRANTY IS AND SHALL BE VIKING'S SOLE AND EXCLUSIVE WARRANTY AND SHALL BE IN LIEU OF ALL OTHER WARRANTIES, EXPRESS OR IMPLIED, INCLUDING, BUT NOT LIMITED TO, ALL WARRANTIES OF MERCHANTABILITY, FITNESS FOR A PARTICULAR PURPOSE AND NON-INFRINGEMENT ALL OF WHICH OTHER WARRANTIES ARE EXPRESSLY EXCLUDED.

See complete warranty at www.vikingpump.com.

IDEX
CORPORATION