

EV Counter

Linear Gage
Counter

User's Manual

Read this User's Manual thoroughly
before operating the instrument. After reading,
retain it close at hand for future reference.

Mitutoyo

CONVENTIONS USED IN USER' S MANUAL

Safety Precautions

To operate the instrument correctly and safely, Mitutoyo manuals use various safety signs (Signal Words and Safety Alert Symbols) to identify and warn against hazards and potential accidents.

The following signs indicate **general** warnings:



Indicates an imminently hazardous situation which, if not avoided, will result in serious injury or death.



Indicates a potentially hazardous situation which, if not avoided, could result in serious injury or death.



Indicates a potentially hazardous situation which, if not avoided, may result in minor or moderate injury or property damage.

The following signs indicate **specific** warnings or prohibited actions, or indicate a mandatory action:



Alerts the user to a specific hazardous situation. The given example means " Caution, risk of electric shock" .



Prohib its a specific action. The given example means " Do not disassemble" .



Specifies a required action. The given example means " Ground" .

CONVENTIONS USED IN USER' S MANUAL

On Various Types of Notes

The following types of **notes** are provided to help the operator obtain reliable measurement data through correct instrument operation.

-
- IMPORTANT**
- An **important note** is a type of note that provides information essential to the completion of a task. You cannot disregard this note to complete the task.
 - An important note is a type of precaution, which if neglected could result in a loss of data, decreased accuracy or instrument malfunction/failure.
-

NOTE A **note** emphasizes or supplements important points of the main text. A note supplies information that may only apply in special cases (e.g.. Memory limitations, equipment configurations, or details that apply to specific versions of a program).

TIP A **tip** is a type of note that helps the user apply the techniques and procedures described in the text to their specific needs. It also provides reference information associated with the topic being discussed.

Mitutoyo assumes no liability to any party for any loss or damage, direct or indirect, caused by use of this instrument not conforming to this manual. Information in this document is subject to change without notice.

© Copyright Mitutoyo Corporation. All rights reserved.

PRECAUTIONS

To obtain the optimum performance from it, obey the following precautions



-
- Neither remove the cover nor disassemble this counter.
Doing so may expose personnel to electric shock or result in damage or fire to this counter due to a short circuit caused by metal chippings or dust.
 - Note the warning labels on the top surface of this counter.
 - This counter is a precision instrument. Do not bump or apply excessive force to any part of this counter when setting it up or operating it.
 - Use this counter in an environment where the temperature is between 0°C and 40°C. The temperature variation should be minimized so there is no condensation.
 - Avoid operating this counter in the following places:
where it will be exposed to cutting chips and oil, dirt, dust, or significant vibrations,
where it will be exposed to direct sunlight,
or near high-voltage/large current power equipment.
-

WARRANTY

In the event that the Mitutoyo EV Counter should prove defective in workmanship or material, within one year from the date of original purchase for use, it will be repaired or replaced, at our option, free of charge upon its prepaid return to us.

This warranty shall not apply if the product has been subject to fair wear and tear, abuse through misuse or improper use/handling/storage/maintenance/service/repair or through adaptation/modification by the original purchaser or any third party without prior written consent of Mitutoyo or as a result of damage by an actual disaster or circumstances beyond the control of Mitutoyo.

To obtain service under this warranty the product must be returned to the nearest Mitutoyo Service Center. Any postage, insurance, or shipping charges incurred in returning the product for service are the responsibility of the purchaser.

- * This warranty is not transferable and is only valid within the country of the original purchase.
- * You may have additional rights under the laws of country of original purchase that do not allow the exclusion of implied warranties or the exclusion or limitation of certain damages. If these laws apply, Mitutoyo's limitations and exclusions may not apply to you.

CONTENTS

CONVENTIONS USED IN USER'S MANUAL	i
PRECAUTIONS	iii
WARRANTY	iv
1 OVERVIEW	1-1
1.1 EV Counter	1-1
1.1.1 Features	1-1
1.1.2 Name and dimensions of each part	1-2
1.2 D-EV External Display Unit (optional)	1-5
1.2.1 Features	1-5
1.2.2 Name and dimensions of each part	1-5
1.3 Internal Block Diagram	1-7
2 SETUP	2-1
2.1 Installing the EV Counter	2-1
2.2 Connecting Cables	2-2
2.2.1 Connecting gages	2-2
2.2.2 Connecting the D-EV (External Display Unit)	2-3
2.2.3 RS-232C, I/O/BCD, and RS LINK connections	2-3
2.2.4 Connecting the power supply and grounding	2-3
2.3 Power On	2-4
3 SETTING PARAMETERS	3-1
3.1 Setting Parameters (with D-EV)	3-1
3.1.1 Parameter mode ON	3-1
3.1.2 Specifying the gage resolution (for EV-16P and EV-16Z)	3-2
3.1.3 Setting the axes to be used	3-2
3.1.4 Parameter mode OFF	3-3
3.1.5 List of parameters	3-4
3.2 Setting Parameters (with EV Counter)	3-6
3.2.1 Parameter mode ON	3-6
3.2.2 Setting the parameters	3-7
3.2.3 Parameter mode OFF	3-7
3.2.4 List of parameters	3-8

CONTENTS

4 BASIC OPERATION	4-1
4.1 Power ON Precautions	4-1
4.2 Switching the Display/Output CH (with D-EV)	4-2
4.3 Switching the Peak Mode (with D-EV)	4-4
4.4 Clearing the Peak Value (with D-EV)	4-5
4.5 Input of Preset Value/Tolerance Value (with D-EV)	4-6
4.6 Clearing the Error State	4-8
4.7 Presetting (with the D-EV)	4-9
4.8 Tolerance Judgment (with the D-EV)	4-10
5 RS-232C COMMUNICATION FUNCTION	5-1
5.1 RS-232C Connection	5-1
5.2 RS-232C Output Specifications	5-1
5.2.1 Specifications of cables and connectors	5-1
5.2.2 Communication specifications	5-1
5.2.3 Pin assignment	5-2
5.2.4 List of available commands	5-2
5.2.5 RS-232C command and RS-232C response output	5-5
5.2.6 HOLD input and RS-232C response output	5-5
5.2.7 Time required for RS-232C data output	5-6
6 RS LINK FUNCTION	6-1
6.1 Connection Method	6-1
6.2 Start-Up Method	6-2
6.3 Troubleshooting	6-3
7 I/O FUNCTION	7-1
7.1 Overview of the I/O function	7-1
7.2 Connectors	7-1
7.3 Input/Output Circuit	7-1
7.3.1 Output circuit	7-1
7.3.2 Input circuit	7-1
7.4 NORMAL Mode	7-2
7.4.1 Overview of the NORMAL mode	7-2
7.4.2 Tolerance judgment output	7-2
7.4.3 BCD output	7-4
7.4.4 Segment output	7-6
7.5 Calculation Mode	7-10
7.5.1 Overview of the calculation mode	7-10
7.5.2 Tolerance judgment result output	7-10
7.5.3 BCD output	7-11
7.5.4 Segment output	7-11

CONTENTS

7.6 High-speed Mode	7-12
7.6.1 Overview of the high-speed mode	7-12
7.6.2 Tolerance judgment result output	7-13
7.6.3 BCD output	7-13
7.6.4 Segment output	7-13
7.7 Timing Chart	7-14
7.7.1 Power ON characteristics	7-14
7.7.2 Output period of tolerance judgment result	7-14
7.7.3 Data output	7-15
7.7.4 External presetting	7-16
7.7.5 Designating CELs to be output/Specifying the calculation method	7-17
7.7.6 Peak clear	7-17
7.7.7 HOLD timing	7-18
8 SPECIFICATIONS	8-1
8.1 Specifications	8-1
8.2 Standard Accessories	8-1
8.3 Optional Accessories	8-2
8.4 List of Error Outputs	8-3

SERVICE NETWORK

1

OVERVIEW

This chapter outlines the features of the EV Counter for linear gages.

1.1 EV Counter

1.1.1 Features

- Three models of EV counter (EV-16P, EV-16D, and EV-16Z) are available according to the linear gage connected. The applicable gages for each model are as follows.

EV-16P: LGF, LGB, and LGE series linear gage (excluding the models that output sine waves)

EV-16D: LGD and LGS series linear gage

EV-16Z: LGF-Z series linear gage

- EV counter is a multi-axis counter to which plural gages can be connected. The maximum number of gages that each model can connect is 6.

Only EV-16Z supports the origin embedded gages.

- The origin function of EV-16Z realizes high-speed response and reduces the time and labor taken by referencing with a master each time the power is turned on.
- With the RS LINK function a maximum of ten EV Counter units can be linked. This makes it possible to construct a system consisting of a maximum of sixty linear gages through one RS-232C port, which is on, for example, a personal computer.
- The display unit is of a separate type (optional) which takes in-line use into consideration.
- Depending on the external devices to be connected and uses, the following I/F connection and output mode can be selected:

[Connection I/F]

Tolerance judgment output

Separately outputs the judgment result from each CEL.

Segment output

Outputs the range specified by the external signal after evenly dividing it into \pm ten stages.

The objective CEL to be output and its range can be specified with the external SET signal.

BCD output

Output of sign and 6-digit data.

The objective CEL to be output can be designated with the external SET signal.

RS-232C/RS LINK

A maximum of 10units/60 channels can be linked.

Preset and tolerance values can be remotely controlled.

Can be used simultaneously with other I/O devices.

[Output mode]

NORMAL mode (factory-set default)

Calculation mode

Calculate the sum, mean, maximum, minimum, and width between the specified CELs and outputs the results.

High-speed mode

Quickly outputs the specified CEL.

1.1.2 Name and dimensions of each part

1) EV-16P

Unit: mm

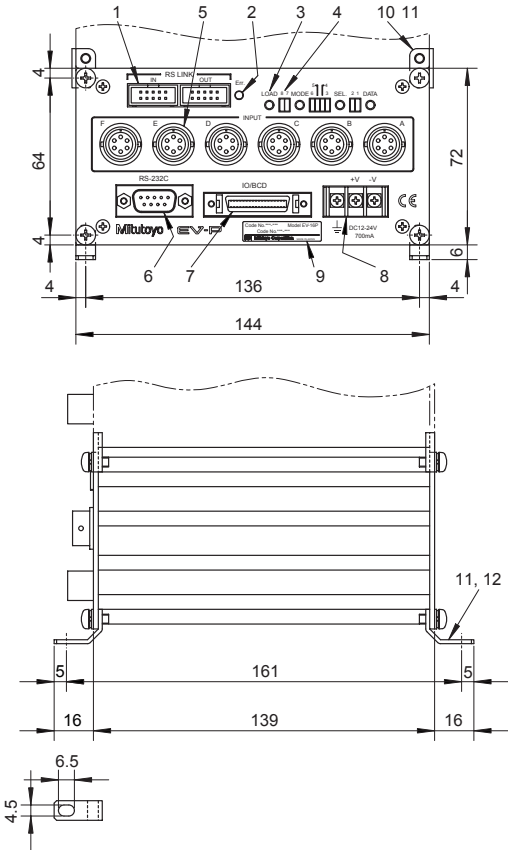

1. RS LINK connector
2. Error LED
3. Parameter input switch (4 pieces)
4. Parameter LED (8 pieces)
5. Gage input connector (INPUT A - F)
6. RS-232C connector
7. I/O connector
8. Power inlet terminal strip
9. Name plate
10. Junction bracket*
11. M4 x 8 screw*
12. Fixing leg*

* Standard accessory

2) EV-16D

Unit: mm

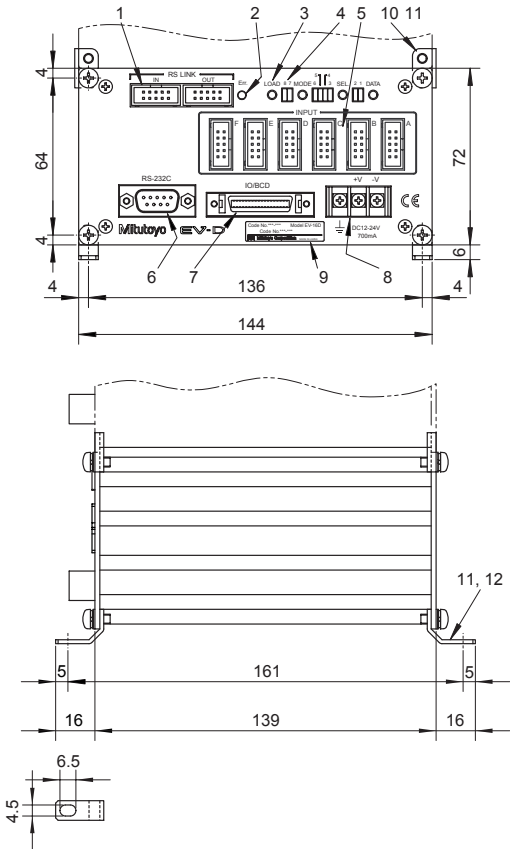

- | | |
|---------------------------------------|------------------|
| 1. RS LINK connector | 2. Error LED |
| 3. Parameter input switch (4 pieces) | |
| 4. Parameter LED (8 pieces) | |
| 5. Gage input connector (INPUT A - F) | |
| 6. RS-232C connector | 7. I/O connector |
| 8. Power inlet terminal strip | 9. Name plate |
| 10. Junction bracket* | |
| 11. M4 x 8 screw* | |
| 12. Fixing leg* | |

* Standard accessory

3) EV-16Z

Unit: mm

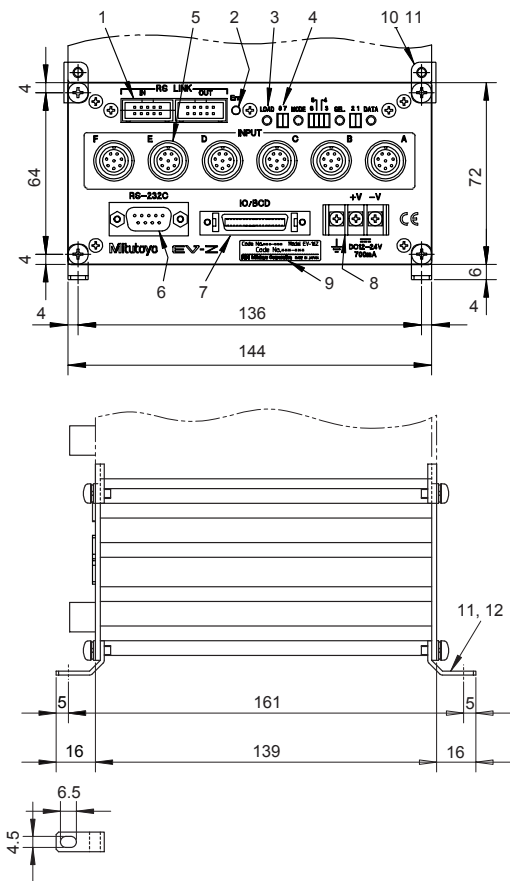

1. RS LINK connector
2. Error LED
3. Parameter input switch (4 pieces)
4. Parameter LED (8 pieces)
5. Gage input connector (INPUT A - F)
6. RS-232C connector
7. I/O connector
8. Power inlet terminal strip
9. Name plate
10. Junction bracket*
11. M4 x 8 screw*
12. Fixing leg*

* Standard accessory

1.2 D-EV External Display Unit (optional)

1.2.1 Features

The D-EV External Display Unit is an optional product used to set the measurement conditions (parameters) and externally display EV Counter measurements.

A single D-EV can display/set up one EV Counter.

1.2.2 Name and dimensions of each part

1) D-EV appearance (front view)

Unit: mm

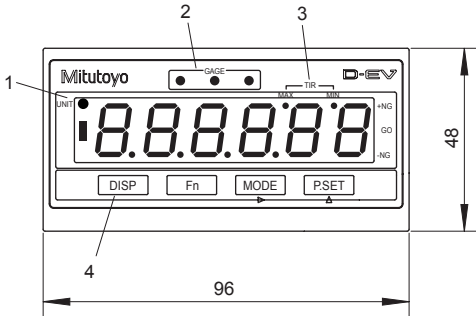

1. UNIT LED
2. GAGE No. LED
3. Peak mode LED
4. Key switch

2) D-EV appearance (side view)

Unit: mm

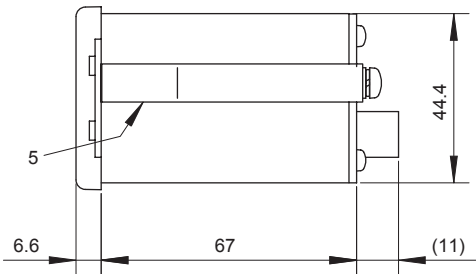

5. Panel-mounting bracket

3) D-EV appearance (rear view)

Unit: mm

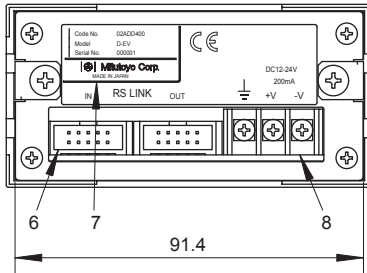

- 6. RS LINK connector
- 7. Name plate
- 8. Power inlet terminal strip

1.3 Internal Block Diagram

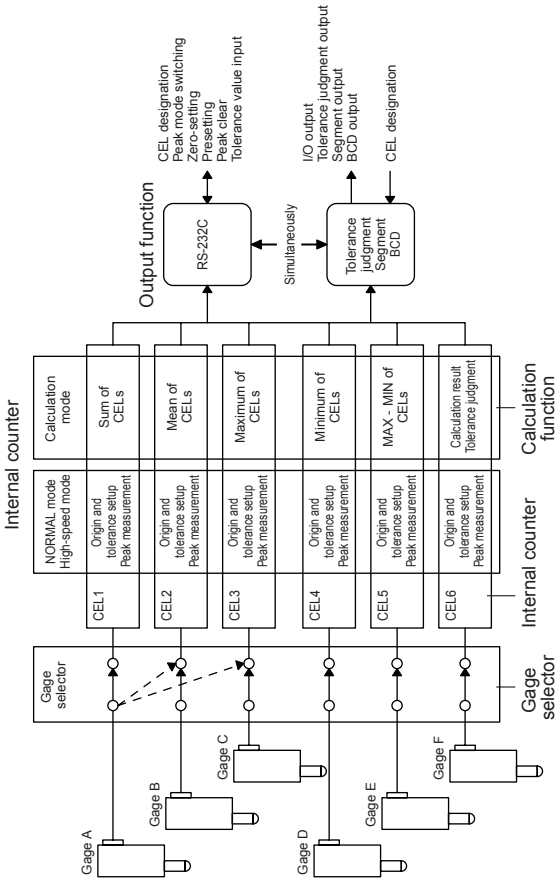

Gage selector:

By setting the appropriate parameters it is possible to connect a single gage output either to one internal counter or to multiple internal counters. With this function, multiple origins and tolerance setups can be set for a single gage.

Internal counter:

Origin setup, peak measurement, and tolerance setup can be performed individually for each of the six internal counters (CEL1 - CEL6).

Calculation function:

Each of the internal counters has a specific calculation function. Therefore, calculation can be performed between the counters specified by the parameters.

Output function:

Either RS-232C, BCD, tolerance judgment, or segment output can be selected. The objective CEL to be output can be selected using the RS-232C command or SET signal.

2

SETUP

This chapter describes the method used to install and connect the EV Counter and make its initial conditions.

2.1 Installing the EV Counter

Both the front and rear panels of the EV Counter have four mounting holes. Use the fixing legs and junction brackets which come as the standard accessories to install the EV Counter.

a) The fixing legs

(1) Attach the fixing legs (4 places) on the counter main unit using the supplied screws.

(2) Use the oval hole provided on each fixing leg to secure the counter to an appropriate surface.

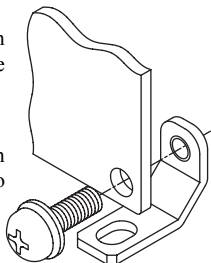

b) The junction brackets

Use the junction brackets and supplied screws to join the two panels along the vertical.

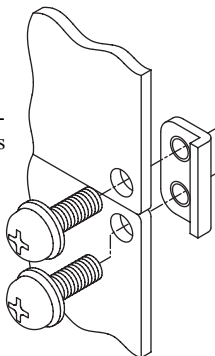

2.2 Connecting Cables

- IMPORTANT**
- Connection should be made only after the power to the main unit and to the partner device of the connection have been turned off. Otherwise, the counter main unit and the connected device will be damaged.
 - Use a 12 - 24VDC power supply with a control output current of 1A or greater. Do not draw power from a source which is used by high-power equipment.
 - Do not route the power cable, I/O cable, RS-232C cable, RS LINK cable, or gage connection cable with other power cables.
 - Use a shielded I/O cable not longer than 3m.
 - Always ground.
 - Each cable should be secured (to, for example, the main body of the device).
-

2.2.1 Connecting gages

- (1) Sequentially connect the required number of linear gages to the corresponding connectors, starting with the INPUT A connector.
- (2) If the EV-16P or EV-16Z is connected to a gage that does not have a resolution of 1 μ m, refer to section 3.1 Setting Parameters (with D-EV) and section 3.2 Setting Parameters (with EV Counter) to adjust the resolution.

- NOTE**
- The gage resolution has been factory-set to 1mm.
 - It is not necessary to modify the resolution on the EV-16D.
-

- (3) Set the parameter for designating available axes according to the number of gages to be connected.
(Refer to section 3.1 Setting Parameters (with D-EV) and section 3.2 Setting Parameters (with EV Counter)).

2.2.2 Connecting the D-EV (External Display Unit)

If a D-EV (External Display Unit) is used, make the necessary connections according to the following procedure.

- (1) Connect the RS LINK OUT connector of the EV Counter to the RS LINK IN connector of the D-EV using an RS LINK connection cable.

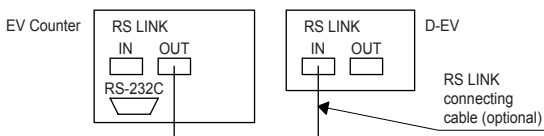

NOTE Always use the RS LINK connection cable specified by Mitutoyo. Refer to section 8.3 Optional Accessories.

- (2) To link more than one counter with the RS LINK connection cables, refer to chapter 6 RS LINK FUNCTION.

TIP The D-EV will display the data of the EV Counter which is connected to the RS LINK IN connector of the D-EV.

2.2.3 RS-232C, I/O/BCD, and RS LINK connections

The EV Counter has an RS-232C connector, I/O/BCD connector, and RS LINK connector. If these connectors are used, refer to chapter 5 RS-232C COMMUNICATION FUNCTION; chapter 6 RS LINK FUNCTION; and chapter 7 I/O FUNCTION for information about cable connections.

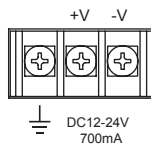

2.2.4 Connecting the power supply and grounding

The EV Counter and D-EV do not have a power switch. Power is supplied by connecting the power source to the +V and -V terminals on the power inlet terminal strip.

IMPORTANT Positively ground the grounding terminal.

2.3 Power On

When the power source is connected to the EV Counter, it enters the counting stand-by state. To start operation and enter the counting state, quit the stand-by state.

TIP The counting stand-by function is an alarm function that is entered if there is a power interruption during use.

a) If a D-EV is not connected

- (1) If the EV-16P or EV-16D is used, enter the RS-232C command or I/O signal (a HOLD signal to clear the error) in the EV Counter. For information refer to chapter 5 RS-232C COMMUNICATION FUNCTION; and chapter 7 I/O FUNCTION.
- (2) If the EV-16Z is used, push in the spindles of all connected gages to pass through the origins after completing the procedure (1) described above.

b) If a D-EV is connected

- (1) When the EV Counter and D-EV are on, the counting stand-by state is entered.

[Display on the D-EV]

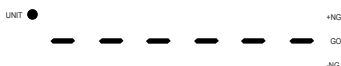

(2)-1

If the EV-16P or EV-16D is used, press the P.SET key to quit the counting stand-by state and enter the counting state.

[Display on the D-EV]



(2)-2

If the EV-16Z is used, press the P.SET key to cancel the counting stand-by mode, then the counter enters the origin detection wait mode. All decimal points flash in the origin detection wait mode.

[Display on the D-EV]



- (3) If the EV-16Z is used, push in the spindle of the connected gages to pass through the origin one after another, and each time it passes through the origin the corresponding bar display of the CH starts flashing.

[Display on the D-EV]

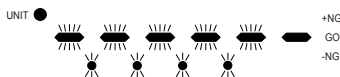

- (4) If the EV-16Z is used, push in the spindles of all connected gages to pass through the origins, then the counter enters the counting mode.

[Display on the D-EV]



- c) Precautions in using the EV-16Z

If the EV-16Z is used, note the following precautions.

IMPORTANT Be sure to pass the spindle through the origin for detection properly. If the spindle vibrates near the origin, the origin may not be detected correctly.

- TIP**
- The origin-embedded gage has a specific origin inside the gage. When the spindle passes through the origin the signal generates, then the preset position is restored.
 - Origin detection is usually performed when the power is turned on. If the origin re-detection parameter (P.No.42) is set to 1, the counter enters the origin detection wait mode after completing preset or tolerance setup (for details, refer to the section, "3.1 Setting Parameters (with D-EV)"), or when the HOLD signal is triggered.
 - If the HOLD signal is input again during origin re-detection, the counter resets origin re-detection, except when resetting an error.

3

SETTING PARAMETERS

This chapter describes the method used to set the parameters required to use the EV Counter.

3.1 Setting Parameters (with D-EV)

Before using the EV Counter, various parameters must be set up. This section explains the setup method using the essential parameters, "gage resolution" (for EV-16P and EV-16Z) and "designation of available axes", as examples.

NOTE For the resolution of 0.1 μ m setting, a D-EV is absolutely necessary.

3.1.1 Parameter mode ON

Set the parameter mode to ON to modify the existing parameter settings.

- (1) Press the P.SET key while holding down the Fn key to set the parameter mode to ON.

[Display on the D-EV]

UNIT 00 _ _ _ 0 +NG
GO
-NG

- (2) Press the P.SET key one more time to modify the setup value to 1.

[Display on the D-EV]

UNIT 00 _ _ _ 1 +NG
GO
-NG

NOTE If a parameter setting needs to be modified, first modify the setting of Parameter 00 to 1. Parameter modification cannot be attempted while the setting of Parameter 00 is 0 (Reference mode).

- (3) Begin setting the parameters.

- (3) To complete the setting operation press the P.SET key while holding down the Fn key. If the EV-16Z is used, push in the spindle to pass through the origin.

In order to continue the setup operation for other parameters simply press the Fn key.

TIP Relationship between the parameter setup values and available axes

An EV Counter has six internal counters (CEL 1 - 6). Data of gages connected to the gage input connectors, INPUT A - F, will be displayed/output as the data of CEL 1 - 6, respectively.

Available axes are designated by determining the relationship between INPUT A - F and CEL 1 - 6. The following table lists the possible combinations.

Setup value	CEL1	CEL2	CEL3	CEL4	CEL5	CEL6
1	INPUT A	INPUT A	INPUT A	INPUT A	INPUT A	INPUT A
2*1	INPUT A	INPUT B	INPUT A	INPUT B	INPUT A	INPUT B
3	INPUT A	INPUT B	INPUT C	INPUT A	INPUT B	INPUT C
4	INPUT A	INPUT B	INPUT C	INPUT D	INPUT A	INPUT B
5	INPUT A	INPUT B	INPUT C	INPUT D	INPUT E	INPUT A
6*2	INPUT A	INPUT B	INPUT C	INPUT D	INPUT E	INPUT F

*1: If the setup value is "2", internal counters CEL1, 3, and 5 will display/output the data of INPUT A. Internal counters CEL2, 4, and 6 will display/output the data of INPUT B. By setting a different tolerance value for each of CEL1, 3, and 5, three different types of tolerance judgments can be made from the data of INPUT A.

*2: The factory-set default is "6".

3.1.4 Parameter mode OFF

- (1) Press the P.SET key while holding down the Fn key to set the parameter mode to OFF. If the EV-16Z is used, push in the spindle to pass through the origin. The parameter setup is modified and the Display Unit returns to the count value display.

- NOTE**
- If the P.SET key is pressed during the setup operation and while the Fn key is being held down, the setup operation is interrupted and the count value display is restored. (If the EV-16Z is used, push in the spindle to pass through the origin.) If this occurs, the modifications made up to the interruption are reflected in actual operation.
 - During parameter setup operation, the parameter input switch, RS-232C output, and external signal input are all disabled.

3.1.5 List of parameters

* Factory-set default

No.	Parameter name	Setup value: function
00	Reference/Modification	0*: For reference only 1: Can be modified 2: Not available 3: Not available
10	Parameter clear	1: Resets to factory-set default
11	Selection of counting direction (to be set for each INPUT number)	If the spindle is pushed-in 0*: + counting 1: - counting
12	Case of EV-16P or EV-16Z Specification of gage resolution* ¹ (to be set for each INPUT number)	0: 10μm gage 1: 5μm gage 2*: 1μm gage 3: 0.5μm gage 4: 0.1μm gage
12	Case of EV-16D Specification of gage type	0: INC (LGS series) 1*: ABS (LGD series) 2*: ABS ORG
13	Designation of available axes* ²	6*: 6 gages are used 5: 5 gages are used 4: 4 gages are used 3: 3 gages are used 2: 2 gages are used 1: 1 gage is used
14	Start-up mode	0*: Counting stand-by 1: Counting execution
15	Display unit* ¹	0*: mm * ³ 1: E (=1/25.4 mm)
17	Designation of calculation axis* ⁴	0*: CEL1, 2 1: CEL1, 2, 3 2: CEL1, 2, 3, 4 3: All CELs designated as available axis* ⁵
20	I/O output mode* ⁶	0: Command 1*: Interval
21	I/O output logic* ⁷	Tolerance judgment and segment 0*: Output terminal is L 1: Output terminal is H BCD 0*: H at output 1 1: L at output 1
22	Selection of I/O function* ⁶	0*: NORMAL mode 1: Calculation mode 2: High-speed mode
23	Selection of I/O type* ⁶	0*: Tolerance judgment 1: Segment output 2: BCD output

* Factory-set default

No.	Parameter name	Setup value: function
25	Baud rate* ⁸ , * ⁹	0: 4800 bps 1*: 9600 bps 2: 19200 bps
26	Parity* ⁸ , * ⁹	0: None 1: Odd number 2: Even number
27	Data bits* ⁸ , * ⁹	0*: 7 bits 1: 8 bits
28	HOLD selection* ⁹	0*: HOLD 1: RS-232C output* ¹⁰
41	Origin detect direction (EV-16Z only)	0*: origin detection at + count 1: origin detection at - count
42	Origin re-detection* ¹¹ (EV-16Z only)	0*: not detect 1: detect
43	Origin initialize (EV-16Z only)	Starts with 0 from the origin. 1: initialize (one-shot)

*1: If this parameter is modified, each zero point, preset value, and tolerance value for CEL1 to CEL6 will be cleared.

*2: For information about this function refer to TIP on page 3-3.

*3: This is not modified even if an attempt is made to clear the parameters. If the display unit is set to E, the UNIT LED lights in green.

*4: Sets the CEL to be used for the calculation function. (This function is valid only if Selection of I/O function is set to Calculation mode.)

*5: If all CELs designated as the available axis are selected, CELs to be used for calculation will be as shown in the table below.

Setup value for designating the available axes	CEL to be used for calculation
6	1, 2, 3, 4, 5, 6
5	1, 2, 3, 4, 5
4	1, 2, 3, 4
3	1, 2, 3
2 or 1	1, 2

*6: For information about this function refer to chapter 7 I/O FUNCTION.

*7: The output logic of the data section will vary depending on the I/O type selection result. However, the logic of the input signal, NORMAL, READY, START, and EXTEND output remains fixed.

*8: For information about this function refer to chapter 5 RS-232C COMMUNICATION FUNCTION.

- *9: The parameter modification will be made valid after resetting the power.
- *10: This function will output data from the RS-232C connector if a HOLD signal is input through the I/O connector. In this case, all RS-232C commands will be ineffective.
- *11: For details, refer to the section, "2.3 Power On".

3.2 Setting Parameters (with EV Counter)

Before using the EV Counter, various parameters must be set up. The parameter setup operation is easily performed if a D-EV is used.

IMPORTANT The EV-16Z can not modify the origin-related settings by itself. For making this modification in EV-16Z, prepare a D-EV.

- NOTE**
- Use a D-EV for the resolution of 0.1 μ m setting. Set up of EV Counter alone, is not possible.
 - Only a D-EV allows setting when the modification is made for the parameter no.41, 42, and 43.
 - In order to connect a gage with a resolution that is not 1 μ m, the counter must modify its resolution setting to that of the connected gage if the EV-16P or EV-16Z is used.
 - The gage type (INC, ABS, etc.) must be set for the EV-16D.
 - If the setup is made as (Number of available axes) > (Number of gages), an error display/output (Error40) will result.
If the setup is made as (Number of available axes) < (Number of gages), gages that are not designated will be ignored. For information refer to section 8.4 List of Error Outputs.

3.2.1 Parameter mode ON

Set the parameter mode to ON to modify the existing parameter settings.

- (1) Press the LOAD button while holding down the DATA button to set the parameter mode to ON.

[Parameter LED Indicator]



- (2) Begin setting the parameters.

3.2.2 Setting the parameters

- (1) Select the parameter name using the SEL. button and MODE button. Each time the SEL. button is pressed, the on/off pattern of LEDs No.3, 4, 5, and 6 will change. Each time the MODE button is pressed, the on/off pattern of LEDs No.7 and 8 will change.

[Parameter LED Indicator]

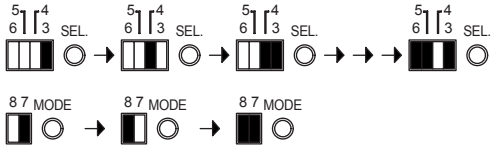

- (2) Select the parameter value using the DATA button. Each time the DATA button is pressed, the on/off pattern of LEDs No.1 and 2 will change.

[Parameter LED Indicator]

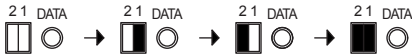

- (3) Accept the parameter value selected by pressing the LOAD button. The next parameter for setup is automatically moved to.

NOTE The modifications will not be reflected in the actual operation unless they have been accepted.

- (4) Repeat steps (1) to (3) to set the other required parameters. (Refer to section 3.2.4 List of parameters.)

3.2.3 Parameter mode OFF

- (1) Press the LOAD button while holding down the DATA button to set the parameter mode to OFF.

[Parameter LED Indicator]

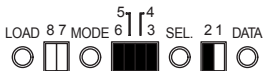

- (2) The count value display will be restored. (after passing through the origin, only EV-16Z restores the count value display)

- NOTE**
- If the LOAD button is held down for more than 1 second while the MODE button is held down, all parameters will be reset to the factory-set defaults.
 - During the parameter setup operation, the D-EV keys, RS-232C output, and external signal input are disabled.

3.2.4 List of parameters

* Factory-set default

Parameter name	LED 8 7 6 5 4 3	Setup content	LED 2 1
Case of EV-16P or EV-16Z			
Resolution of INPUT A* ¹	<input type="checkbox"/> <input type="checkbox"/> <input type="checkbox"/> <input type="checkbox"/> <input type="checkbox"/> <input checked="" type="checkbox"/>	10μm	<input type="checkbox"/> <input type="checkbox"/>
Resolution of INPUT B* ¹	<input type="checkbox"/> <input type="checkbox"/> <input type="checkbox"/> <input type="checkbox"/> <input checked="" type="checkbox"/> <input type="checkbox"/>	5μm	<input type="checkbox"/> <input checked="" type="checkbox"/>
Resolution of INPUT C* ¹	<input type="checkbox"/> <input type="checkbox"/> <input type="checkbox"/> <input checked="" type="checkbox"/> <input checked="" type="checkbox"/> <input checked="" type="checkbox"/>	1μm*	<input checked="" type="checkbox"/> <input type="checkbox"/>
Resolution of INPUT D* ¹	<input type="checkbox"/> <input type="checkbox"/> <input checked="" type="checkbox"/> <input checked="" type="checkbox"/> <input type="checkbox"/> <input type="checkbox"/>	0.5μm	<input checked="" type="checkbox"/> <input checked="" type="checkbox"/>
Resolution of INPUT E* ¹	<input type="checkbox"/> <input checked="" type="checkbox"/> <input type="checkbox"/> <input type="checkbox"/> <input type="checkbox"/> <input checked="" type="checkbox"/>		
Resolution of INPUT F* ¹	<input type="checkbox"/> <input checked="" type="checkbox"/> <input checked="" type="checkbox"/> <input checked="" type="checkbox"/> <input type="checkbox"/> <input type="checkbox"/>		
Case of EV-16D			
Gage type of INPUT A	<input type="checkbox"/> <input checked="" type="checkbox"/> <input type="checkbox"/> <input type="checkbox"/> <input type="checkbox"/> <input checked="" type="checkbox"/>	INC (LGS series)	
Gage type of INPUT B	<input type="checkbox"/> <input checked="" type="checkbox"/> <input type="checkbox"/> <input type="checkbox"/> <input checked="" type="checkbox"/> <input type="checkbox"/>		<input type="checkbox"/> <input type="checkbox"/>
Gage type of INPUT C	<input type="checkbox"/> <input checked="" type="checkbox"/> <input type="checkbox"/> <input type="checkbox"/> <input checked="" type="checkbox"/> <input checked="" type="checkbox"/>	ABS (LGD series)*	
Gage type of INPUT D	<input type="checkbox"/> <input checked="" type="checkbox"/> <input checked="" type="checkbox"/> <input type="checkbox"/> <input type="checkbox"/> <input type="checkbox"/>		<input type="checkbox"/> <input checked="" type="checkbox"/>
Gage type of INPUT E	<input type="checkbox"/> <input checked="" type="checkbox"/> <input checked="" type="checkbox"/> <input checked="" type="checkbox"/> <input checked="" type="checkbox"/> <input checked="" type="checkbox"/>	ABS ORG	<input checked="" type="checkbox"/> <input type="checkbox"/>
Gage type of INPUT F	<input type="checkbox"/> <input checked="" type="checkbox"/> <input type="checkbox"/> <input checked="" type="checkbox"/> <input checked="" type="checkbox"/> <input type="checkbox"/>		
Counting direction of INPUT A	<input checked="" type="checkbox"/> <input type="checkbox"/> <input type="checkbox"/> <input type="checkbox"/> <input type="checkbox"/> <input checked="" type="checkbox"/>	+ Counting*	<input type="checkbox"/> <input type="checkbox"/>
Counting direction of INPUT B	<input checked="" type="checkbox"/> <input type="checkbox"/> <input type="checkbox"/> <input type="checkbox"/> <input type="checkbox"/> <input type="checkbox"/>	- Counting	<input type="checkbox"/> <input checked="" type="checkbox"/>
Counting direction of INPUT C	<input checked="" type="checkbox"/> <input type="checkbox"/> <input type="checkbox"/> <input type="checkbox"/> <input checked="" type="checkbox"/> <input checked="" type="checkbox"/>	If the spindle is pushed-in	
Counting direction of INPUT D	<input checked="" type="checkbox"/> <input type="checkbox"/> <input type="checkbox"/> <input checked="" type="checkbox"/> <input type="checkbox"/> <input type="checkbox"/>		
Counting direction of INPUT E	<input checked="" type="checkbox"/> <input type="checkbox"/> <input type="checkbox"/> <input checked="" type="checkbox"/> <input type="checkbox"/> <input checked="" type="checkbox"/>		
Counting direction of INPUT F	<input checked="" type="checkbox"/> <input type="checkbox"/> <input type="checkbox"/> <input checked="" type="checkbox"/> <input type="checkbox"/> <input type="checkbox"/>		
Designation of available axis 1* ²	<input checked="" type="checkbox"/> <input checked="" type="checkbox"/> <input type="checkbox"/> <input type="checkbox"/> <input type="checkbox"/> <input checked="" type="checkbox"/>	Axis designation 2 is valid*	<input type="checkbox"/> <input type="checkbox"/>
		1 gage is connected	<input type="checkbox"/> <input checked="" type="checkbox"/>
		2 gages are connected	<input checked="" type="checkbox"/> <input type="checkbox"/>
		3 gages are connected	<input checked="" type="checkbox"/> <input checked="" type="checkbox"/>
Designation of available axis 2* ²	<input checked="" type="checkbox"/> <input checked="" type="checkbox"/> <input type="checkbox"/> <input type="checkbox"/> <input checked="" type="checkbox"/> <input type="checkbox"/>	Axis designation 1 is valid*	<input type="checkbox"/> <input type="checkbox"/>
		4 gages are connected	<input type="checkbox"/> <input checked="" type="checkbox"/>
		5 gages are connected	<input checked="" type="checkbox"/> <input type="checkbox"/>
		6 gages are connected*	<input checked="" type="checkbox"/> <input checked="" type="checkbox"/>

3 SETTING PARAMETERS

		* Factory-set default	
Parameter name	LED 8 7 6 5 4 3	Setup content	LED 2 1
Start-up mode	■ ■ □ □ ■ ■	Counting stand-by	□ □
		Counting execution	□ ■
Display unit*1*3	■ ■ □ □ □ □	mm*	□ □
		E (=1/25.4 mm)	□ ■
Designation of calculation axis*4	■ ■ □ □ □ ■	CEL1, 2*	□ □
		CEL1, 2, 3	□ ■
		CEL1, 2, 3, 4	■ □
		All CELs*5	■ ■
I/O output mode*6	■ ■ □ ■ ■ □	Command	□ □
		Interval *	□ ■
I/O output logic*7	■ ■ □ ■ ■ ■	Output terminal is H*	□ □
		Output terminal is L	□ ■
Selection of I/O function*6	■ ■ ■ □ □ □	NORMAL mode*	□ □
		Calculation mode	□ ■
		High-speed mode	■ □
Selection of I/O type*6	■ ■ ■ □ □ ■	Tolerance judgment output*	□ □
		Segment output	□ ■
		BCD output	■ □
Baud rate*8, *9	■ ■ ■ □ □ □	4800 bps	□ □
		9600 bps*	□ ■
		19200 bps	■ □
Parity *8, *9	■ ■ ■ □ □ ■	None	□ □
		Odd number	□ ■
		Even number*	■ □
Data bits*8, *9	■ ■ ■ ■ □ □	7 bits*	□ □
		8 bits	□ ■
HOLD selection*9	■ ■ ■ ■ □ ■	HOLD*	□ □
		RS-232C output *10	□ ■

- *1: If this parameter is modified, each zero point, preset value, and tolerance value for CEL1 to CEL6 will all be cleared.
- *2: For information about this function refer to TIP below.
- *3: This is not modified even if an attempt is made to clear the parameters. If the display unit is set to E, the UNIT LED lights in green.
- *4: Sets the CEL to be used for the calculation function. (This function is valid only if Selection of I/O function is set to Calculation mode.)
- *5: If all CELs designated as the available axis are selected, CELs to be used for calculation will be as shown in the table below.

Setup value for designating the available axes	CEL to be used for calculation
6	1, 2, 3, 4, 5, 6
5	1, 2, 3, 4, 5
4	1, 2, 3, 4
3	1, 2, 3
2 or 1	1, 2

- *6: For information about this function refer to chapter 7 I/O FUNCTION.
- *7: The output logic of the data section will vary depending on the I/O type selection result. However, each logic of the input signal, NORMAL, READY, START, and EXTEND output remains fixed.

Tolerance judgment and segment output	BCD output
<input type="checkbox"/> The corresponding output terminal is L, and others are H.	1=H, 0=L
<input type="checkbox"/> The corresponding output terminal is H, and others are L.	1=L, 0=H
- *8: For information about this function refer to chapter 5 RS-232C COMMUNICATION FUNCTION.
- *9: The parameter modification will be made valid after resetting the power.
- *10: This function will output data from the RS-232C connector if a HOLD signal is input through the I/O connector. In the case of "", all RS-232C commands will be ineffective.

4

BASIC OPERATION

This chapter describes the basic operation of the EV Counter with a D-EV.

4.1 Power ON Precautions

Turn on the power to the EV Counter by referring to section 2.3 Power On.

Neither move the gage stylus nor operate any key until the EV Counter enters the counting stand-by state.

[Counting stand-by state (on D-EV)]

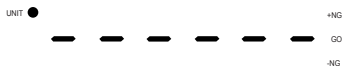

4.2 Switching the Display/Output CH (with D-EV)

Use the DISP key to switch the display/output CH (channel). This section explains the procedure, using the top EV Counter connected via the RS LINK function as an example.

- (1) When the counter enters the counting mode after the power is turned on, the count value of CH01 (CEL1) is displayed on the D-EV, and the corresponding GAGE No. LED is turned on.

[GAGE No. LED Indicator] 

- TIP**
- CH numbers (01 - 99) will be automatically assigned to the EV counters sequentially from the top as they are connected via the RS LINK function. If only one counter is connected, it is assigned CH numbers 01 through 06, which corresponds to CEL1 through CEL6. For more information refer to chapter 5, "RS LINK FUNCTION".
 - GAGE No. LEDs show the currently displayed CEL number with the corresponding on/off pattern.

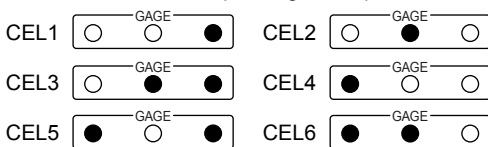

- (2) If the DISP key is pressed, the display/output CH is switched to the next display/output CH, displaying the count value of CH02 (CEL2). While the DISP key is held down, the CH number (CH02) and gage input connector number (= b) is displayed on the D-EV.

[GAGE No. LED Indication] 

[Display on D-EV (while the DISP key is held down)]

UNIT  +NG
GO
-NG

- (3) Each time the DISP key is pressed, the current CH number is switched, sequentially displaying the count values of CH03 (CEL3) to CH06 (CEL6) in order.

- (4) If the DISP key is pressed again, a 6-axis tolerance judgment bar is displayed on the D-EV, showing all the judgment results from CEL1 to CEL6 at the same time.

[Indication of GAGE No. LED] 

[Display on D-EV]

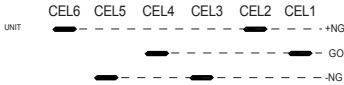

- NOTE**
- While the bar is being displayed, only the DISP key can be operated.
 - The +NG and -NG bars are turned on for a CEL that causes an error.

- (5) If the DISP key is pressed again, the display of CH01 (CEL1) restores.

4.3 Switching the Peak Mode (with D-EV)

The internal counters, CEL1 - CEL6, will hold (lock) the peak values (Max., Min., and TIR) of the count values. Therefore, by switching the peak mode with the MODE key, it is possible to switch the value to be displayed (on the D-EV) or output.

- (1) Press the DISP key to select a CEL number. The count value of the selected CEL will be displayed (on the D-EV) or output.
- (2) Press the MODE key to switch the peak mode. The on/off pattern of the LEDs (on the D-EV) shows the selected peak mode.

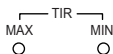
 Current value: Current stylus position

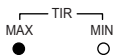
 Max.: Maximum value since the peak value was last cleared.

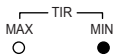
 Min.: Minimum value since the peak value was last cleared.

 TIR: Max. - Min.

-
- NOTE**
- Peak values are retained in memory even when the power is off.
 - The peak mode can be switched by RS-232C communication.
-

4.4 Clearing the Peak Value (with D-EV)

Held (retained) peak values can be cleared as necessary.

- (1) Press the DISP key to select a CEL number. The count value of the selected CEL will be displayed (on D-EV) or output.
- (2) Press the MODE key to select one of the Max., Min., and TIR modes. The corresponding LED on the D-EV is turned on to indicate the selected mode. (Refer to section 4.3 Switching the Peak Mode (with D-EV).)
- (3) Press the P.SET key to clear the peak value.
This results in Max. = Min. = Current value, and TIR = 0.

-
- NOTE**
- If the P.SET key is pressed in the current-value mode, both peak-value clear and presetting are executed. (Refer to section 4.7 Presetting (with D-EV).)
 - Press the P.SET key to clear the peak values of all CELs assigned the same INPUT number. (Example: With available axes = 2 if the peak value of CEL1 is cleared with the P.SET key, the peak values of CEL3 and CEL5 will also be cleared. Refer to section 3.2.4 List of parameters.)
-

4.5 Input of Preset Value/Tolerance Value (with D-EV)

With the D-EV it is possible to input a setting value consisting of a maximum of six digits.

- (1) Press the DISP key to select a CEL number. The count value of the selected CEL will be displayed (on the D-EV) or output.
- (2) Press the Fn key to select the type of setting value (preset value, lower limit, and upper limit). The on pattern of the GAGE No. LED, indicating the selected CEL number, will flash in a different color according to the type of setting value selected, and the current setting value will be displayed on the D-EV.

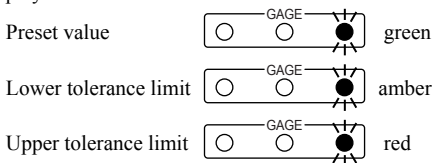

[Display on the D-EV (current value display)]

UNIT  ^{+NG}
_{GO}
_{-NG}

NOTE

The D-EV Counter uses a 6-digit display, however a value consisting of a maximum of eight digits can be set using the RS-232C communication function. If a number consisting of more than seven digits has already been set, the most significant one or two digits will be represented by an "F", as in F34.567, on the display.

- (3) Enter the setting value.
MODE key: Shifts the digit place (flash) for input.
P.SET key: Inputs the setting value (places a digit).
Fn key: Aborts the input operation (modification of the setting value is canceled).

[Display on the D-EV]

UNIT  ^{+NG}
_{GO}
_{-NG}

UNIT 

Either \pm sign must be set with the most significant digit. The displayed number will change in the following order: 0, 1, ...9, -0, -1, ...-9, 0.

- (4) Repeat step 3 as required to place all digits, including the least significant digit.

[Display on the D-EV]

UNIT 0 10.005 ^{+NG} _{-NG}

- NOTE**
- If the gage resolution has been set to $5\mu\text{m}/0.5\mu\text{m}$, set the least significant digit to 0 or 5.
 - Only one set of tolerance values can be set for each CEL.

- (5) While the least significant digit is flashing, press the MODE key. The entered value is accepted and the flashing stops.

[Display on the D-EV]

UNIT 0 10.005 ^{+NG} _{-NG}

- (6) Press the Fn key to move to the next setup item. The selected item will change as follows: preset value, lower limit value, upper limit value, count value.

- NOTE**
- Preset values and tolerance values are retained in memory even when the power is off.
 - Set a lower tolerance limit that is equal to or smaller than the upper tolerance limit. An incorrect setting may cause a tolerance setting error (Err90). If this occurs, press the P.SET key and perform the input operation again, starting with the lower tolerance limit.
 - In the case of using the EV-16D, perform presetting/tolerance limit setting with the linear gage connected, as the connected linear gage sets the resolution automatically.

- TIP**
- If the RS-232C communication function is used, a preset value/tolerance value of a maximum of eight digits can be set.
 - The factory-set default preset value, lower limit value, and upper limit value are as follows:
If a $1\mu\text{m}$ gage is used: 00000.000 / -99999.999 / 99999.999
Display on D-EV: 000.000/ -F99.999/ F99.999

4.6 Clearing the Error State

The error state can be cleared with the following procedures. If the EV-16Z is used, push in the spindle to pass through the origin after completing the following procedures.

- (1) Press the DISP key to select a CEL number in the error state. Then press P.SET key.
- (2) The HOLD input signal rises to "H". (I/O)
- (3) Input the CS command. (RS-232C)

-
- NOTE**
- While the error state is being canceled, Error40 is displayed (on D-EV) or output.
 - While the error state is being canceled, the GAGE No. LED flashes.
 - Time required for error cancelation: 30ms (EV-16P and EV-16Z), max. 8s (EV-16D)
-

4.7 Presetting (with the D-EV)

Replace the current value with a preset value.

- (1) Press the DISP key to select a CEL number. The count value of the selected CEL will be displayed (on the D-EV) or output.
- (2) Press the MODE key to select the current-value mode. The on/off pattern of the LEDs show the selected mode.

[MODE LED Indicators]

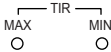

- (3) Press the P.SET key to replace the current value (displayed value) with a preset value. At this time the peak values will be cleared and Max. = Min. = Current value, and TIR = 0.

- NOTE**
- The EV Counter can count a maximum of eight digits, however the D-EV Counter can display a maximum of six digits. If a number has more than six digits, the most significant one or two digits will be represented by an "F". If the count value returns to a number of six digits or less, the D-EV also returns to normal display.

Example)

Count value of EV Counter main unit: 1000.001

Display on the D-EV: F00.001

- If the EV-16D is connected to an ABS_ORG type gage, approximately four seconds is required for the preset value to be recalled on the EV-16D. During this time do not move the spindle. Doing so may displace the zero point.
- An ABS or ABS_ORG type gage can be preset one million times (nominal).

4.8 Tolerance Judgment (with the D-EV)

Three tolerance judgment result stages can be displayed on the GAGE No. LEDs and output through the I/O connector. (For more information about the I/O output function refer to chapter 7 I/O FUNCTION.)

- (1) Press the DISP key to select a CEL number. The count value of the selected CEL will be displayed (on the D-EV) or output.
- (2) Press the MODE key to select one of the peak modes: Max., Min., and TIR. The GAGE No. LED's on pattern, indicating the selected CEL number will light in a different color according to the tolerance judgment result.
(Display example of tolerance judgment result from CEL1)

+NG:  Red

(upper tolerance limit < design value)

GO:  Green

(lower tolerance limit ≤ design value ≤ upper tolerance limit)

-NG:  Amber

(design value < lower tolerance limit)

-
- NOTE**
- There will always be six I/O output channels.
 - The tolerance judgment result can be also verified with the 6-axis tolerance judgment bar display. (Refer to section 4.2 Switching the Display/Output CH (with the D-EV).
-

5

RS-232C COMMUNICATION FUNCTION

This chapter describes the RS-232C communication function.

5.1 RS-232C Connection

Connect the specified cable (D-sub, 9-pin cross-type cable) to the RS-232C connector. The user must separately purchase this cable.

NOTE If multiple EV Counters are connected via the RS LINK function, connect the above-mentioned cable to the RS-232C connector of the first EV Counter.

5.2 RS-232C Output Specifications

5.2.1 Specifications of cables and connectors

Receptacle specification:

D-sub, 9-pin (male) inch-screw specification

Applicable plug specification:

D-sub, 9-pin (female) inch-screw specification

Examples of commercially available cables:

DOS/V: KRS-403XF 1K (1.5m, Manufacturer: Sanwa Supply)

PC-98: KRS-423XF 1K (1.5m, Manufacturer: Sanwa Supply)

5.2.2 Communication specifications (Conforms to EIA: RS-232C standard)

Home position	DTE (terminal), with cross-type cable
Communication method	Half-duplex, teletype protocol
Data transfer rate	4800, 9600, 19200bps
Bit configuration	Start bit: 1 bit Data bits: 7 or 8-bit ASCII uppercase characters Parity bit: None, Even number, Odd number Stop bit: 2 bits
Communication condition settings	To be set with parameters Refer to chapter 3 SETTING PARAMETERS.

5.2.3 Pin assignment

Pin No.	Signal name	I/O	Description
1	NC	----	Not connected
2	RXD	I	Received Data
3	TXD	O	Transmission Data
4	DTR	O	Data Terminal Ready
5	GND	----	Ground
6	DSR	I	Data Set Ready
7	RTS	O	Request to Send
8	CTS	I	Clear to Send
9	NC	----	Not connected

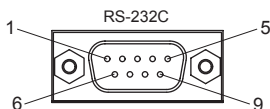

5.2.4 List of available commands

Command format	Corresponding output	Operation
GA**CRLF	G#** +01234.567CRLF	Outputs the displayed value.*1
CN**CRLF	CH**CRLF	Switches to the current value display
CX**CRLF	CH**CRLF	Switches to the max. value display
CM**CRLF	CH**CRLF	Switches to the min. value display
CW**CRLF	CH**CRLF	Switches to the TIR display
CR**CRLF	CH**CRLF	Zero-sets.
CL**CRLF	CH**CRLF	Clears peak values
CP**, +01234.567CRLF	CH**CRLF	Presets.*2
CD**, +01234.567CRLF	CH**CRLF	Inputs lower tolerance limit*2,*3
CG**, +01234.567CRLF	CH**CRLF	Inputs upper tolerance limit*2,*3
CS**CRLF	CH**CRLF	Clears the error.
CK**CRLF	CH**, %CRLF	Returns the HOLD status*4,*6
CT\CRLF	CH\ +01234,567CRLF	Outputs the calculation data*5,*6,*7

*1: A "#" denotes the data type (N: Current value, X: Maximum, M: Minimum, W: TIR).

*2: For a preset value or tolerance value input a number that consists of a maximum of eight digits (not including a decimal point) and its sign.

*3: For the tolerance setting, first enter the lower limit value, then the upper limit value.

An error will result if the entries are not made in this order. If this is the case, make the setting again, starting with the CD command entry.

*4: The response output value (%) for the entered CK command represents the HOLD status.

% = 1: The counter is in the HOLD state.

% = 0: The counter is not in the HOLD state.

*5: Precautions to be observed when calculation data is output by the CT command:

This command is valid only if the I/O function selection parameter is set to "Calculation mode".

A double backslash (\) is used to specify the calculation method between the axes which have been specified by the calculation axis designation parameter.

Value of double backslash	Operation
01, 07*, 12**	Obtains each total of specified axes.
02, 08*, 13**	Obtains each mean of specified axes.
03, 09*, 14**	Obtains the max. value of specified axes.
04, 10*, 15**	Obtains the min. value of specified axes.
05, 11*, 16**	Obtains Max. - Min. of specified axes.

If more than one EV Counter unit is connected via the RS-LINK function:

*: Value of double backslash on the second counter.

** : Value of double backslash on the third counter.

*6: An all-channels specification is not permitted with the CK or CT command. If all channels are specified, a command error results.

*7: The CT command cannot be used with the EF Counter.

- NOTE**
- A double asterisk (**) denotes a channel number between 01 and 99 (00 means all channels).
 - CRLF means a CR (carriage return) and an LF (line feed).
 - The output when an error occurs will be "CH", Error\$\$CRLF".
 ("\$\$" denotes the error code number. Refer to section 8.4 List of Error Outputs.)
 - Send the next command only after the response output to the current command has been received. If no response to the current command has been received, clear the buffer and wait for more than one second, then send the same command again.

-
- The RS-232C communication function is suspended during a parameter, preset value, or tolerance value setup operation. If the counting state is restored, output of the command or data will be resumed.
 - To quit the counting stand-by state use "CS00CRLF" (all-channels specification).
 - Note that the GA command and CT command look similar, however, their functions differ.
GA command: Outputs the count data of a CH specified by "##".
CT command: Outputs the calculation result specified by a double backslash.
 - If the peak mode is switched using an RS-232C command, peak values cannot be backed up in memory.
-

5.2.5 RS-232C command and RS-232C response output

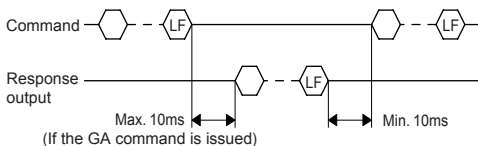

NOTE During key operation RS-232C output will be suspended, and it will be resumed after the key operation has been completed.

5.2.6 HOLD input and RS-232C response output

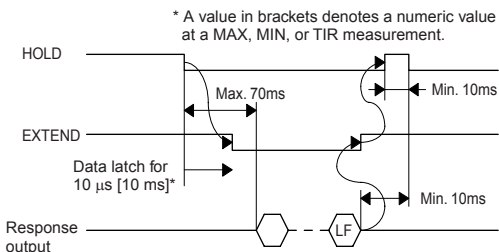

- NOTE**
- During key operation RS-232C output will be suspended, and it will be resumed after the key operation has been completed.
 - If the RS LINK connection has been established, the EXTEND command is valid for the counter placed at the end of the chain.
 - EXTEND output will be in effect only if the I/O mode parameter is set to "Interval mode".
 - While the HOLD signal is being input, the D-EV UNIT LED flashes.
 - In order to trigger data output from the RS-232C connector with the HOLD input signal set the HOLD selection parameter to "RS-232C". (In this state an RS-232C command cannot be input.)
 - If the High-speed mode is specified, set the output cell to "All CELs".

5.2.7 Time required for RS-232C data output

The maximum output time (ms) as a result of executing the all-data output command (GA00CRLF) is calculated as follows:

= (number of connected counters x 10) + (number of available channels x 17) + 6

[= (number of connected counters x 10) + (number of available channels x 8.5) + 3]

Transmission speed: 9600bps [19200bps]

(Example)

One EV-16P unit (total 6 gage channels): Max. 118ms [64ms]

Ten EV-16P units (total 60 gage channels): Max. 1126ms [610ms]

-
- NOTE**
- "Number of connected counters x 20" is used for EF Counters.
 - The above figures do not include personal computer processing time.
 - The data size required if total 60 gage channels are used, is 900 bytes (15 bytes per gage channel). For more information refer to the specifications of the reception-side personal computer.
-

6

RS LINK FUNCTION

This chapter describes the RS LINK function that controls multiple counters connected via dedicated cables.

6.1 Connection Method

A maximum of ten EV Counter units can be chain-connected, and all the counters can be controlled through the RS-232C interface of the top counter. (Refer to chapter 5 RS-232C COMMUNICATION FUNCTION.)

Link the IN side of the RS LINK connector of one EV Counter with the OUT side of the RS LINK connector of another EV Counter, as shown below.

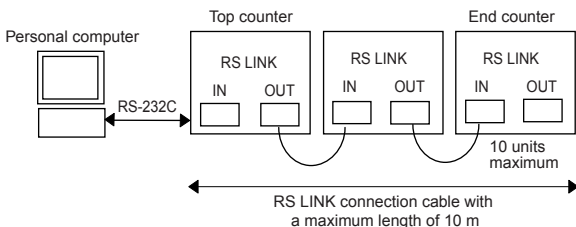

If one D-EV is inserted in the middle, as shown below, it will display the data of EV Counter: A.

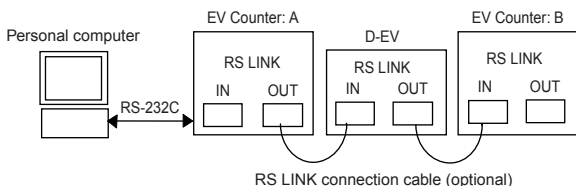

- NOTE**
- Do not connect anything to the IN side of the RS LINK connector of the top counter. Also, do not connect anything except a D-EV to the OUT side of the RS LINK connector of the end counter.
 - The CH numbers of the gages connected to each EV Counter will be automatically assigned as CH01, CH02, CH03..., from INPUT A of the top counter when the power is turned on (during the initial setup). On the second EV Counter, CH07, CH08,....CH12 will be assigned.

-
- One or more EF Counters can be combined with the EV Counters. However, if this is done, a maximum of six EF Counters can be combined. A D-EV, if inserted, will not be included in the number of connected units.
 - The maximum total length of the RS LINK cables used in the entire system is 10m.
 - Consult Mitutoyo to construct a system with more than 10 counters and/or a total cable length greater than 10m.
-

6.2 Start-Up Method

Start up the entire system with the following procedure.

- (1) Either turn on the power to all the EV Counters/D-EVs simultaneously or turn on the power sequentially, starting from the top EV Counter/D-EV. The initial setup will commence.
During initial setup, the D-EV displays a flashing "-----".
- (2) If the initial setup has been completed, the flashing "-----" on the D-EV will fix (indicating the counting stand-by state).
- (3) Quit the counting stand-by state by either pressing the P.SET key or by inputting an external HOLD or RS command. (Refer to section 8.4 List of Error Outputs.)

-
- NOTE**
- RS-232C-related parameters can only be modified on the top counter.
 - If the existing parameters are modified, reset the power to all the connected counters.
 - Always set the start-up mode to the counting stand-by mode (factory-set default).
-

6.3 Troubleshooting

If communication with the personal computer is not functioning well, refer to the following examples:

- If no response to the entered command is received from the EV Counter.
 - 1) Is the RS LINK cable connected properly?
 - 2) Is a straight-type RS-232C cable used?
 - 3) Are the personal computer and EV Counter communication conditions consistent?
 - 4) With some computers it is necessary to specify the communication port and whether it is to be used. Is a cable properly connected to the specified port?
 - 5) Is key operation or parameter setup operation being performed?
(During the above-mentioned operations, RS-232C communication function is paused/suspended.)
- The initial setup operation cannot be terminated ("-----" flashes on the D-EV).
- Some counter enter the counting stand-by state ("-----" is displayed on the D-EV) while the power is being turned on.
 - 1) Is the RS LINK cable connected properly?
 - 2) If EF Counters are being used with EV Counters, make sure that the Digimatic selection parameter of the EF Counter is set to "RS LINK".

After removing the cause of the error, reset the power to all counters.

- A command (such as a zero-set or preset command) from the personal computer can be executed, but no data can be acquired. Or, data processing is stopped during data acquisition.
 - 1) Is the response output from the counter read with such as the zero-set command, etc?
 - 2) Is the next command issued before the response output from the counter is received?
 - 3) Is the number of channels connected via the RS LINK function consistent with the number of data pieces to be acquired?
- A command anomaly occurs if a command is issued.
 - 1) Was a command consisting of 2-byte characters or lower-case characters issued?
 - 2) Don't you specify a number greater than the number of channels connected?



7

I/O FUNCTION

This chapter describes the I/O function related to data input and output.

7.1 Overview of the I/O function

According to the I/O-type selection parameter, the I/O connector will perform tolerance judgment output, BCD output, and segment output. Each output can be performed in the NORMAL mode, calculation mode, or high-speed mode as set by the I/O function selection parameter. (Refer to chapter 3 SETTING PARAMETERS.)

NOTE The user must separately purchase the connection cable.

7.2 Connectors

Receptacle: 10236-52A2 (Manufacturer: 3M, half-pitch 36-pin, female)

Plug: 10136-3000VE (Manufacturer: 3M) or equivalent

Cover: 10336-52A0-008 (Manufacturer: 3M) or equivalent

7.3 Input/Output Circuit

7.3.1 Output circuit

Application: Tolerance judgment output, NORMAL, and segment output

Operation: Transistor turned ON at "L" (open-collector output)

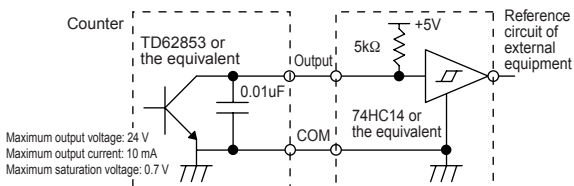

7.3.2 Input circuit

Application: P.SET, HOLD, SET

Operation: Input enabled at "L"

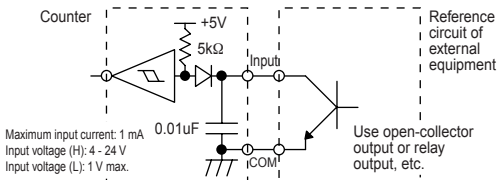

7.4 NORMAL Mode

7.4.1 Overview of the NORMAL mode

- The NORMAL mode is the factory-set default. Use it without modification for general purposes.
- Origin setting, tolerance setting, and presetting can be performed individually for each CEL.
- Tolerance judgment (for each CEL), BCD data, and segment (on selected CELs) output can be performed.

7.4.2 Tolerance judgment output

1) Function

Outputs the tolerance judgment result of each internal counter (CEL1 to CEL6).

Measured value < Lower tolerance limit -NG output

Lower tolerance limit ≤ Measured value ≤ Upper tolerance limit
GO output

Upper tolerance limit < Measured value +NG output

2) Parameter setup

I/O function selection parameter: Set to NORMAL

I/O-type selection parameter: Set to tolerance judgment

3) Pin assignment

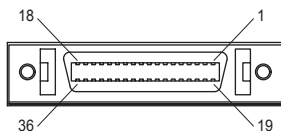

No.	Name	I/O	Functional description	
1	COM		Common terminal of I/O circuit (connected to internal GND)	
2	COM			
3	CEL1_-NG	OUT	Tolerance judgment result of CEL1	-NG
4	CEL1_GO	OUT	Tolerance judgment result of CEL1	GO
5	CEL1_+NG	OUT	Tolerance judgment result of CEL1	+NG
6	CEL1_NOM	OUT	Error signal of CEL1*1	
7	CEL2_-NG	OUT	Tolerance judgment result of CEL2	-NG
8	CEL2_GO	OUT	Tolerance judgment result of CEL2	GO
9	CEL2_+NG	OUT	Tolerance judgment result of CEL2	+NG
10	CEL2_NOM	OUT	Error signal of CEL2*1	
11	CEL3_-NG	OUT	Tolerance judgment result of CEL3	-NG
12	CEL3_GO	OUT	Tolerance judgment result of CEL3	GO
13	CEL3_+NG	OUT	Tolerance judgment result of CEL3	+NG
14	CEL3_NOM	OUT	Error signal of CEL3*1	
15	CEL4_-NG	OUT	Tolerance judgment result of CEL4	-NG
16	CEL4_GO	OUT	Tolerance judgment result of CEL4	GO
17	CEL4_+NG	OUT	Tolerance judgment result of CEL4	+NG
18	CEL4_NOM	OUT	Error signal of CEL4*1	

No.	Name	I/O	Functional description
19	CEL5_-NG	OUT	Tolerance judgment result of CEL5 -NG
20	CEL5_GO	OUT	Tolerance judgment result of CEL5 GO
21	CEL5_+NG	OUT	Tolerance judgment result of CEL5 +NG
22	CEL5_NOM	OUT	Error signal of CEL5*1
23	CEL6_-NG	OUT	Tolerance judgment result of CEL6 -NG
24	CEL6_GO	OUT	Tolerance judgment result of CEL6 GO
25	CEL6_+NG	OUT	Tolerance judgment result of CEL6 +NG
26	CEL6_NOM	OUT	Error signal of CEL6*1
27	EXTENDED	OUT	L: Execution of an RS-232C command, which is activated by a HOLD input, is being performed. H: Execution of an RS-232C command, which was activated by a HOLD input, has been completed. Purpose: Monitoring the RS data communication condition at the I/O port.
28	READY	OUT	"L" if the output data has been accepted.
29	START	OUT	"L" only when CEL1 data has been output.
30	NORMAL	OUT	"H" at an anomaly. (Result of ORing NOMs of all CELs.)
31	P.SET	IN	Presets the specified CELs.
32	OUTCEL	IN	Sets the output CEL/calculation method specified by SET1 through SET3 if the ON signal of OUTCEL was input.
33	SET1	IN	
34	SET2	IN	
35	SET3	IN	
36	HOLD	IN	The display value is held during input. The error is cleared at the rise of this signal. Only EV-16Z re-detects the origin if the parameter No.42 is set to 1.

*1: "L" if counting is permitted.

*: Outputs of No.3 through No.26 can be logically inverted by the I/O output logic parameter.

** : Inputs of No.31 through No.36 are valid at "L".

4) Designating the CEL for "P.SET"

For the detailed procedure, refer to section 7.7.4 External presetting.

SET3	SET2	SET1	CEL specified
0	0	0	All CELs
0	0	1	CEL1
0	1	0	CEL2
0	1	1	CEL3
1	0	0	CEL4
1	0	1	CEL5
1	1	0	CEL6
1	1	1	Specification prohibited.

0="H" 1="L"

7.4.3 BCD output

- 1) Function
Outputs the CEL data specified by the output CEL designation as a BCD (6 digits).
- 2) Parameter setup
I/O function selection parameter: Set to NORMAL
I/O-type selection parameter: Set to BCD output
- 3) Pin assignment

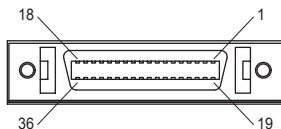

No.	Name	I/O	Functional description	
1	COM		Common terminal of I/O circuit (connected to internal GND)	
2	COM			
3	1×10^0	OUT	BCD output data	
4	2×10^0	OUT		
5	4×10^0	OUT		
6	8×10^0	OUT		
7	1×10^1	OUT		
8	2×10^1	OUT		
9	4×10^1	OUT		
10	8×10^1	OUT		
11	1×10^2	OUT		
12	2×10^2	OUT		
13	4×10^2	OUT		
14	8×10^2	OUT		
15	1×10^3	OUT		
16	2×10^3	OUT		
17	4×10^3	OUT		
18	8×10^3	OUT		
19	1×10^4	OUT		
20	2×10^4	OUT		
21	4×10^4	OUT		
22	8×10^4	OUT		
23	1×10^5	OUT		
24	2×10^5	OUT		
25	4×10^5	OUT		
26	8×10^5	OUT		
27	SIGN	OUT		Sign of count value ("H" for "+" and "L" for "-")
28	READY	OUT		"L" if the output data has been accepted.
29	START	OUT	"L" if only CEL1 data has been output.	
30	NORMAL	OUT	"H" at an anomaly	
31	P.SET	IN	Presets the specified CELs.	

No.	Name	I/O	Functional description
32	OUTCEL	IN	Sets the output CEL/calculation method specified by SET1 through SET3 if the ON signal of OUTCEL was input. In NORMAL/High-speed mode: CEL designation In calculation mode: Specification of calculation method
33	SET1	IN	
34	SET2	IN	
35	SET3	IN	
36	HOLD	IN	The display value is held during the input. The error is cleared at the rise of this signal. Only EV-16Z re-detects the origin if the parameter No.42 is set to 1.

*: Outputs of No.3 through No.27 can be logically inverted by the I/O output logic parameter.

** : Inputs of No.31 through No.36 are valid at "L".

4) Designating CELs to be output

For the detailed procedure, refer to section 7.7.5 Designating CELs to be output/Specifying the calculation method.

SET3	SET2	SET1	Operation
0	0	0	Outputs the data of all CELs as a time-division BCD (power-on default)
0	0	1	BCD output of CEL1 data
0	1	0	BCD output of CEL2 data
0	1	1	BCD output of CEL3 data
1	0	0	BCD output of CEL4 data
1	0	1	BCD output of CEL5 data
1	1	0	BCD output of CEL6 data
1	1	1	Specification prohibited.

0="H" 1="L"

7.4.4 Segment output

1) Function

Outputs the CEL data specified by the output CEL designation as segment data.

The segment output function is used to evenly divide the measurement range previously set into 21 segments, so that the 21 tolerance judgment stages of the measured value can be output.

21 pins numbered from -L10 to +L10 are used for this segment output.

2) Parameter setups

I/O function selection parameter: Set to NORMAL.

I/O-type selection parameter: Set to segment output

3) Pin assignment

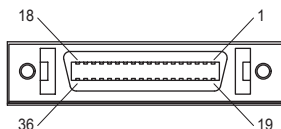

No.	Name	I/O	Functional description
1	COM		Common terminal of I/O circuit (connected to internal GND).
2	COM		
3	-OV	OUT	To be output if the measured value exceeds the measurement range.
4	-L10	OUT	Segment output data.
5	-L9	OUT	
6	-L8	OUT	
7	-L7	OUT	
8	-L6	OUT	
9	-L5	OUT	
10	-L4	OUT	
11	-L3	OUT	
12	-L2	OUT	
13	-L1	OUT	
14	L0	OUT	
15	+L1	OUT	
16	+L2	OUT	
17	+L3	OUT	
18	+L4	OUT	
19	+L5	OUT	
20	+L6	OUT	
21	+L7	OUT	
22	+L8	OUT	
23	+L9	OUT	
24	+L10	OUT	

No.	Name	I/O	Functional description
25	+OV	OUT	To be output if the measured value exceeds the measurement range.
26	NOM	OUT	"H" at an anomaly
27	EXTEND	OUT	L: Execution of an RS-232C command, which was activated by a HOLD input, is being performed. H: Execution of an RS-232C command, which was activated by an HOLD input, has been completed. Purpose: Monitoring the RS data communication condition at the I/O port.
28	READY	OUT	"L" if the output data has been accepted.
29	START	OUT	"L" if only CEL1 data has been output.
30	NORMAL	OUT	"H" at an anomaly
31	P.SET	IN	Presets the specified CELs.
32	OUTCEL	IN	Sets the output CEL/calculation method specified by SET1 through SET3 if the ON signal of OUTCEL was input. In the NORMAL/High-speed mode: CEL designation. In the calculation mode: Specification of calculation method.
33	SET1	IN	
34	SET2	IN	
35	SET3	IN	
36	HOLD	IN	The display value is held during the input. The error is cleared at the rise of this signal. Only EV-16Z re-detects the origin if the parameter No.42 is set to 1.

*: Outputs of No.3 through No.26 can be logically inverted by the I/O output logic parameter.

** : Inputs of No.31 through No.36 are valid at "L".

4) Designating CELs to be output

For the detailed procedure, refer to section 7.7.5 Designating CELs to be output/Specifying the calculation method.

SET3	SET2	SET1	Operation
0	0	0	Outputs the data of all CELs as time-division segment data (power-on default)
0	0	1	Segment output of CEL1 data
0	1	0	Segment output of CEL2 data
0	1	1	Segment output of CEL3 data
1	0	0	Segment output of CEL4 data
1	0	1	Segment output of CEL5 data
1	1	0	Segment output of CEL6 data
1	1	1	Specification prohibited.

0="H" 1="L"

- 5) Measurement range: Can be specified/modified by inputting SET1 through SET3 (For more information, refer to section 7.7.5 Designating CELs to be output/Specifying the calculation method.)

List of measurement ranges: If the peak mode is set to current value, MAX, or MIN.

SET 1	SET 2	SET 3	Measurement range (mm)/ Resolution (mm)			
			10 μ m gage	5 μ m gage	1 μ m gage	0.5 μ m gage
0	0	0	0 \pm 0.1 /0.01	0 \pm 0.05 /0.005	0 \pm 0.01 /0.001	0 \pm 0.005 /0.0005
0	0	1	0 \pm 0.2 /0.02	0 \pm 0.1 /0.01	0 \pm 0.02 /0.002	0 \pm 0.01 /0.001
0	1	0	0 \pm 0.5 /0.05	0 \pm 0.25 /0.025	0 \pm 0.05 /0.005	0 \pm 0.025 /0.0025
0	1	1	0 \pm 1 /0.1	0 \pm 0.5 /0.05	0 \pm 0.1 /0.01	0 \pm 0.05 /0.005
1	0	0	0 \pm 2 /0.2	0 \pm 1 /0.1	0 \pm 0.2 /0.02	0 \pm 0.1 /0.01
1	0	1	0 \pm 5 /0.5	0 \pm 2.5 /0.25	0 \pm 0.5 /0.05	0 \pm 0.25 /0.025
1	1	0	0 \pm 10/1	0 \pm 5/0.5	0 \pm 1/0.1	0 \pm 0.5/0.05
1	1	1	0 \pm 20/2	0 \pm 10/1	0 \pm 2/0.2	0 \pm 1/0.1

List of measurement ranges: If the peak mode is set to TIR.

SET 1	SET 2	SET 3	Measurement range (mm)/ Resolution (mm)			
			10 μ m gage	5 μ m gage	1 μ m gage	0.5 μ m gage
0	0	0	0-0.2 /0.01	0-0.1 /0.005	0-0.02 /0.001	0-0.01 /0.0005
0	0	1	0-0.4 /0.02	0-0.2 /0.01	0-0.04 /0.002	0-0.02 /0.001
0	1	0	0-1.0 /0.05	0-0.5 /0.025	0-0.1 /0.005	0-0.05 /0.0025
0	1	1	0-2 /0.1	0-1 /0.05	0-0.2 /0.01	0 \pm 0.1 /0.005
1	0	0	0-4 /0.2	0-2 /0.1	0-0.4 /0.02	0-0.2 /0.01
1	0	1	0-10 /0.5	0-5 /0.25	0-1 /0.05	0-0.5 /0.025
1	1	0	0-20/1	0-10/0.5	0.1(0)-2/0.1	0-1/0.05
1	1	1	0-40/2	0-20/1	0-4/0.2	0-2/0.1

Each resolution (range of one segment) is a value derived from the measurement range evenly divided by twenty.

Example: If the measurement range = 0.1mm, the resolution = 0.01mm.

6) Relationship between the measurement value and output terminal

If a segment output is designated, the output terminal (corresponding terminal L_n) corresponding to the measurement value is turned ON.

'n' of corresponding terminal L_n ($-10 \leq n \leq +10$, n is an integer) can be calculated as follows. (If n is between -10 and -1, the corresponding terminal will be between -L10 and -L1.)

Peak mode	Formula for n
Current value	If the measurement value is positive:
MAX	$n = \text{INT}\{(\text{measurement value} + 1/2 \text{ resolution}) / \text{resolution}\}$
MIN	If the measurement value is negative $n = \text{INT}\{(\text{measurement value} - 1/2 \text{ resolution}) / \text{resolution}\}$
TIR	$n = -10 + \text{INT}(\text{measurement value} / \text{resolution})$

7) Output pattern

The segment output pattern varies with the peak mode setup.

Peak mode	Output
Current value	Only the corresponding terminal, L_n , is ON.
MAX	Corresponding terminals from -L10 to L_n are ON.
MIN	Corresponding terminals from L_n to +L10 are ON.
TIR	Only the corresponding terminal, L_n , is ON.

NOTE Output at range-over

Should a +0V (the measurement exceeds the upper limit) or -0V (the measurement falls below the lower limit) range-over occur, all terminals between -L10 to +L10 will be set to OFF.

- TIP**
- Difference between CH01=A and CH01_A
A CEL that is represented so as to include "=" when the display is switched with the DISP key, is output with the I/O function. A CEL that is represented so as to include "_" is not output by the I/O function.
 - How to make general tolerance judgment
Before tolerance judgment output, set the I/O output logic parameter to "Output terminal is H". This enables general tolerance judgment, in which the output is "H" if all the CELs, which are connected in such a way that the GO output of each CEL is connected by means of hard-wire OR operation, result in GO.

7.5 Calculation Mode

7.5.1 Overview of the calculation mode

- 1) Using the CEL that has been specified by the calculation axis designation parameter, output the calculation result specified by the input of SET1 to SET3, as shown below.
- 2) Setting the calculation method
(For the detailed procedure, refer to section 7.7.5 Designating CELs to be output/Specifying the calculation method .)

SET3	SET2	SET1	Calculation method
0	0	0	No calculation (power-on default)
0	0	1	Sum of CEL data on specified calculation axes
0	1	0	Mean of CEL data on specified calculation axes
0	1	1	Max. of CEL data on specified calculation axes
1	0	0	Min. of CEL data on specified calculation axes
1	0	1	MAX - MIN of CEL data on specified calculation axes
1	1	0	Specification prohibited.
1	1	1	Specification prohibited.

0="H" 1="L"

7.5.2 Tolerance judgment result output

- 1) Function
 - A tolerance judgment of the calculation result will be output from CEL6.
 - In case of no calculation, a tolerance judgment to the count value of CEL6 will be output.
 - The tolerance limits for CEL6 will be applied.
- 2) Parameter setup
 - I/O function selection parameter: Set to the calculation mode.
 - I/O-type selection parameter: Set to tolerance judgment.
 - Calculation axis designation parameter:
Select one between 0 and 3.

TIP • Display on the D-EV when the calculation mode is being set.

If the display is switched with the DISP key, the following will be sequentially displayed after normal display (CH01 to CH06 and 6-axis tolerance judgment bar):

Displays the sum after displaying CL01_1.

Displays the mean after displaying CL02_2.

Displays the maximum value after displaying CL03_3.

Displays the minimum value after displaying CL04_4.

Displays the MAX - MIN after displaying CL05_5.

For the second EV Counter on the RS LINK, the following will be displayed:

Displays the sum after displaying CL07_1.

Displays the mean after displaying CL08_2.

Displays the maximum value after displaying CL09_3.

Displays the minimum value after displaying CL10_4.

Displays the MAX - MIN after displaying CL11_5.

* All the keys except the DISP key will be disabled in the calculation mode.

- Difference between CH06=F and CH06_F.

If the setups of SET1 to SET3 are not '000' (some calculation item has been specified), and if CH06 is specified with the DISP key, the measured value will be displayed after 'CH06_F' is displayed. This means that "_" indicates that tolerance judgment output is not performed for the CH06 measurement value (i.e. the tolerance judgment output is performed for the calculation result).

In other cases, where SET=000, a tolerance judgment will be output to the measured value of CH06 and the measured value will be displayed after 'CH06=F' is displayed.

7.5.3 BCD output

1) Function

- Outputs the calculation results specified by SET1 through SET3 as the BCD data.
- Outputs the data of all CELs as a time-division BCD, if the setups of SET1 to SET3 are "000".

2) Parameter setup

- I/O function selection parameter: Set to the calculation mode.
- I/O-type selection parameter: Set to BCD output.
- Calculation axis designation parameter: Select one between 0 and 3.

7.5.4 Segment output

1) Function

- Outputs the calculation result specified by the input of SET1 to SET3 as segment data.
- If SET3 through SET1 are all "000", the data of all CELs will be output in a time-divided format.

2) Parameter setups

- I/O function selection parameter: Set to the calculation mode.
- I/O type selection parameter: Set to segment output.
- Calculation axis designation parameter: Select one between 0 and 3.

7.6 High-speed Mode

7.6.1 Overview of the high-speed mode

- 1) Quickly outputs the CEL data specified by the output CEL designation.
- 2) Data output interval in the high-speed mode
5ms (30ms in NORMAL mode)
- 3) Designating CELs to be output
For the detailed procedure, refer to section 7.7.5 Designating CELs to be output/Specifying the calculation method.

SET3	SET2	SET1	Output CEL
0	0	0	Outputs the data of all CELs in a time-division output format, as in the NORMAL mode (power-on default).
0	0	1	High-speed output of CEL1 data*
0	1	0	High-speed output of CEL2 data*
0	1	1	High-speed output of CEL3 data*
1	0	0	High-speed output of CEL4 data*
1	0	1	High-speed output of CEL5 data*
1	1	0	High-speed output of CEL6 data*
1	1	1	Specification prohibited.

0="H" 1="L"

* Other CEL output functions are disabled.

NOTE About operation during suspension

- Presetting, peak clear, or zero-setting operation (with D-EV, I/O, RS-232C) for CELs other than those which have been specified by SET1 through SET3 will be suspended, and they become effective only after the CEL has been specified.
 - Even if the tolerance judgment bar display is active, only the bars of CELs that have been specified will operate.
 - RS-232C output from CELs other than those which have been specified by SET1 through SET3 will be the previous data (existed when the suspension state began).
 - If the CELs, excluding that which is displayed on the D-EV, are specified for output CEL designation, the display values will be held (locked).
 - If key operation is attempted on the D-EV, the I/O function will output all CEL data in a time-division format.
-

7.6.2 Tolerance judgment result output

- 1) Function
A tolerance judgment of the CEL, which has been specified by output CEL designation, will be output at high speed.
- 2) Parameter setups
 - I/O function selection parameter: Set to the high-speed mode.
 - I/O-type selection parameter: Set to tolerance judgment output.

7.6.3 BCD output

- 1) Function
Quickly outputs the CEL data specified by output CEL designation as BCD data.
- 2) Parameter setups
 - I/O function selection parameter: Set to the high-speed mode.
 - I/O-type selection parameter: Set to BCD output.

7.6.4 Segment output

- 1) Function
Quickly outputs the CEL data specified by output CEL designation as segment data.
- 2) Parameter setups
 - I/O function selection parameter: Set to the high-speed mode.
 - I/O-type selection parameter: Set to segment output .

7.7 Timing Chart

7.7.1 Power ON characteristics

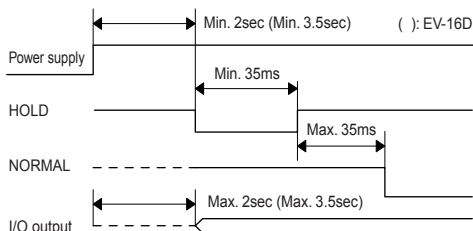

If linked to RS-LINK, the counter that is turned on last will be used as the reference.

7.7.2 Output period of tolerance judgment result

CEL outputs are not simultaneous.

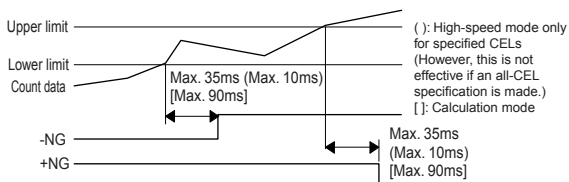

NOTE With an EV-16D, the output period varies according to the gage connected.

7.7.3 Data output

There are two data output methods that can be specified by the I/O output mode parameter: the command mode and the interval mode.

1) Command mode (for outputting all CELs)

With synchronized control of the HOLD and READY signals, the data of all CELs (specified by SET1 through SET3) will be output.

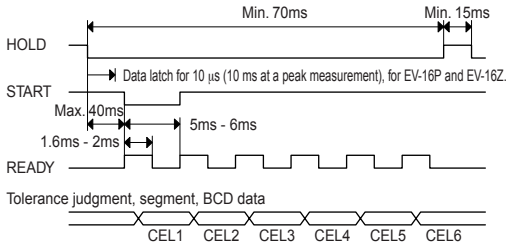

* While the HOLD signal is being input, the UNIT LED (on D-EV) will flash.

2) Command mode (for outputting individual CELs)

With synchronized control of the HOLD and READY signals, the data of each CEL (specified by SET1 through SET3) will be output.

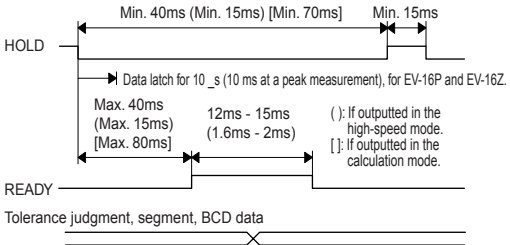

NOTE If this command is used in the high-speed mode or in the all-CELs output mode, use a device that has an input response time that is less than 1ms.

3) Interval mode (for outputting all CELs)

According to the internal timing of the counter, the data of all CELs (specified by SET1 through SET3) will be output sequentially.

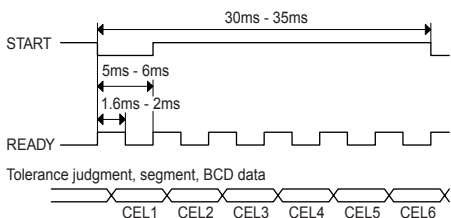

4) Interval mode (for outputting individual CELs)

According to the internal timing of the counter, the data of each CEL (specified by SET1 through SET3) will be output sequentially.

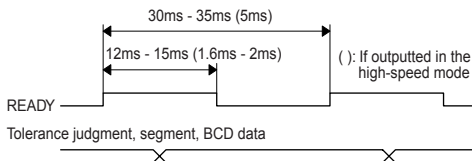

7.7.4 External presetting

Use the current value of a CEL specified by SET1 through SET3 as a preset value.

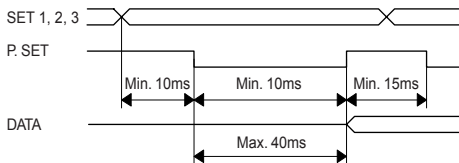

If presetting has been executed, the peak values will be cleared. (Max. = Min. = current value, TIR = 0)

7.7.5 Designating CELs to be output/Specifying the calculation method

Assign a CEL that has been specified by SET1 through SET3 as the data output CEL.

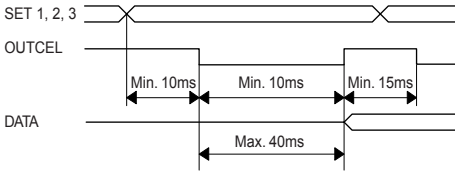

Inputs of SET1 through SET3 for segment output

Usually, these function as range specification data (or as output CEL designation data if an OUTCEL signal is input). Refer to section 7.4.4 Segment output.

Operation varies depending on the setups of the I/O function selection parameter.

- NORMAL or high-speed mode: Output CEL designation.
- Calculation mode: Specification of calculation method.

7.7.6 Peak clear

Clears the peak values.

(Max.= Min. = current value, TIR = 0)

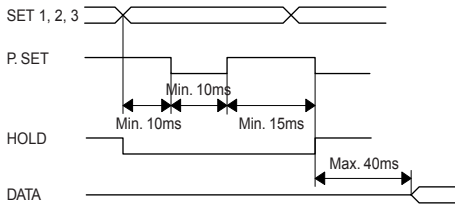

- NOTE**
- Peak clear will be effective if the peak mode setup is other than "Current value". If "Current value" is specified, presetting is performed.
 - With the EV-16D, the data update period depends on the gage connected. In addition, the same data may be output repeatedly over multiple cycles.

7.7.7 HOLD timing

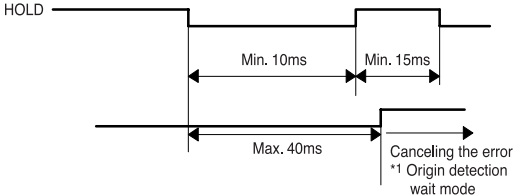

*1: Only EV-16Z re-inputs the origin (if the parameter No.42 is set to 1).

8

SPECIFICATIONS

This chapter describes the EV Counter specifications, supplied accessories, and each error output, the cause, and the remedies.

8.1 Specifications

Code No.	542-063	542-067	542-064
Model No.	EV-16P	EV-16Z	EV-16D
Number of connectable gages	6	6	6
Counting range (Gage resolution)	± 999999.99 (10 μ m) ± 99999.995 (5 μ m) ± 99999.999 (1 μ m) ± 9999.9995 (0.5 μ m) ± 9999.9999 (0.1 μ m)		Depends on gage connected
Maximum counting speed	5MHz		-----
Maximum input frequency	1.25MHz (two-phase square wave) Response time depends on the gage to be used.		-----
Power supply voltage	DC12V - 24V, 700mA, from terminal strip (M3 screw)		
Power consumption	8.4VA		
External dimensions	144 x 72 x 139mm (W x H x D)		
Operation temperature	0°C to 40°C (20 to 80%RH, without condensation)		
Storage temperature	-10°C to 50°C (20 to 80%RH, without condensation)		
Mass	Approx. 910g		Approx. 830g

8.2 Standard Accessories

Part No.	Name	Quantity
02ADD301	Foot	4
02ADD302	Junction bracket	4
-----	Mounting screw M4 x 12	8
99MBC034B	Operation Manual (this manual)	1
A42F08-003C	Supplemental operation manual	1
-----	Certificate	1

8.3 Optional Accessories

Part No.	Name
02ADD400	D-EV External Display Unit
02ADB440	Output connector (with cover)
02ADD950	RS LINK connection cable (0.5 m)
936937	RS LINK connection cable (1 m)
995014	RS LINK connection cable (2 m)
02ADD930	Terminal strip connection cable *
02ADN460	AC adapter
02ZAA000	AC cable (Japan, &c.) *
02ZAA010	AC cable (USA, &c.) *
02ZAA020	AC cable (EU, &c.) *
02ZAA030	AC cable (UK, &c.) *
02ZAA040	AC cable (China, &c.) *
02ZAA050	AC cable (Korea, &c.)*

* Required if the AC adapter is used.

I/O output				D-EV	EV main unit	RS output*4	Possible cause of error	Cancellation method	Remedy
NORMAL signal	Tolerance*1	Segment*1	BCD*1	Display/ UNIT LED	Error LED/ Parameter LED				
H	CEL*_+NG=L CEL*_-NG=L CEL*_NOM=H	NOM=H +OV=L -OV=L	FFFF10	Err10/ On in red	On in amber/ No display	Error10	Abnormal power supply voltage	Self-cancellation	Connect to the specified power supply.
H	CEL*_+NG=H*9 CEL*_-NG=H CEL*_NOM=H	NOM=H*9 +OV=H -OV=H	FFFFFF*9	"----" flashes/Off	Flashes in amber/ No display	None	Initial conditions of RS LINK	Self-cancellation or power reset	Check the RS LINK cable connection.
H	CEL*_+NG=L CEL*_-NG=L CEL*_NOM=H	NOM=H +OV=L -OV=L	FFFF15	"----" lights/On in red	On in amber/ No display	Error15	Counting stand-by state when power turned on Power interruption	P.SET key CS00 command (RS) HOLD input (I/O)	In the power is interrupted, check the power supply.
H	CEL*_+NG=L CEL*_-NG=L CEL*_NOM=H	NOM=H*2	FFFF20*2	Err 20*2/ On in red	On in amber/ On*6	Error20	Over-speed	Press the P.SET key after specifying a CEL with the DISP key. CS** command (RS) HOLD input (I/O)	Review the measurement conditions.
H	CEL*_+NG=L CEL*_-NG=L CEL*_NOM=H	NOM=H*2	FFFF30*2	Err 30*2/ On in red	On in amber/ On*6	Error30	The count value is more than 8 digits.	Same as above	Modify the preset value.
H	CEL*_+NG=L CEL*_-NG=L CEL*_NOM=H	NOM=H*2	FFFF40*2	Err 40*2/ On in red	On in amber/ On*6	Error40	Gage anomaly*7	Same as above*10	Check the gage connection.

I/O output NORMAL signal	I/O output			D-EV	EV main unit	RS output*4	Possible cause of error	Cancellation method	Remedy
	Tolerance*1	Segment*1	BCD*1	Display/ UNIT LED	Error LED/ Parameter LED				
L	Counting state	Counting state	Counting state	Count/ Off	No display	Error50	Abnormal RS communication setup	Self-cancellation	Check the RS communication conditions.
L	Counting state	Counting state	Counting state	Count/ Off	No display	Error52	Abnormal RS command	Self-cancellation	Review the RS command.
H	CEL* ₋ +NG=L CEL* ₋ -NG=L CEL* ₋ NOM=H	NOM=H +OV=L -OV=L	FFFF55	Err 55/ On in red	On in red/ No display	None	RS LINK anomaly	Power reset P.SET key CS** command (RS) HOLD input (I/O)	Check the unit connections and power supply, etc.
L	Counting state	Counting state	Counting state	Err 90*3/ Off	No display	Error90*5	Tolerance setup error	P.SET key	Re-enter the tolerance value.
L	Counting state	Counting state	F*****	F*****/ Off	No display	Normal output	The count value more than 6 digits.	Self-cancellation	Not required*8
L	CEL* ₋ +NG=L CEL* ₋ -NG=L CEL* ₋ NOM=H	NOM=H +OV=L -OV=L	FFFF70	Err 70/ Off	No display	Error70	Gages resolutions specified by the calculation axis designation are not consistent. Calculation result causes overflow.	Self-cancellation	Replace the gages with gages that have an identical resolution.
L	Counting state	Counting state	Counting state	All decimal points flash	No display	None	Origin is not detected	Self-cancellation	Push in the spindle to pass through the origin

NOTE If an error occurs during a parameter, preset value, or tolerance value setting operation, the error code will be displayed only after the counting state has been restored. However, the error code will be output immediately. In the high-speed mode, an error code will be output only if the CH that caused the error is specified for output. If the EV-16Z is used, perform origin re-input after removing the error cause to cancel the error.

- *1: This operation is performed when the I/O output logic parameter has the initial setting.
- *2: The error code will be output and displayed when the CH that caused the error is specified for output.
- *3: Displayed if a tolerance setup error occurs due to a key operation.
- *4: The error output format will be CH**,Error\$\$CRLF.
- *5: Output if a tolerance setup error occurs due to an RS command.
- *6: A parameter LED (1 to 6) corresponding to the CH that caused the error will be turned on.
- *7: Any CH, to which the gage is not properly connected according to the available axis designation parameter, will cause an error.
- *8: The count data in the EV counter is normal. The display will be restored to the normal state when the count data falls within the displayable range.
- *9: Irrespective of the I/O logic, "H" will be output if an error occurs.
- *10: Automatically canceled if the gage type parameter has been set to 1 or 2 with the EV-16D.

Mitutoyo Corporation

20-1, Sakado, 1-chome, Takatsu-ku,
Kawasaki, Kanagawa 213-0012, Japan

Cable: MITUTOYO Kawasaki

Phone: (044) 813-8230

Fax: (044) 813-8231

Printed in Japan