

microTHERM™ oil

Circulating Oil Temperature Control System



System Model Number and Rating _____	
Part Number _____	Serial Number _____
Customer _____	
Customer Order Number _____	Date _____

Issue Date
July 2012

User's Instruction Manual
Part Number: 161-123417-025
PQ446-1

Table of Contents

Section	Topic	Page
1	Getting Started	1
2	Installation.....	4
3	Temperature Control	10
4	Operation	15
5	Diagnostics.....	18
6	Maintenance.....	20
7	Troubleshooting	26
8	Specifications.....	28
9	Index.....	31

Illustrations

Figure	Topic	Page
1.1	System Photo	2
1.2	Control Panel	3
2.1	Piping.....	6
2.2	Piping Connections.....	7
2.3	Power Connection Terminals.....	8
2.4	Control Voltage Fuse.....	9
3.1	Control Panel Layout	10
3.2	Controller Displays	11
3.3	Controller PAGE/MENU Selections	12
5.1	Diagnostic Indicators	18
5.2	Pump Reset Switch.....	19
5.3	Over Temperature Controller Reset Switch.....	19
6.1	Electrical Schematic, Heat, Cool.....	23
6.2	Electrical Schematic, Heat, Cool, SCR.....	24
8.1	Pump Capacity	28
8.2	Power and Capacity Information	28
8.3	Replacement Parts Identification.....	29

Section 1

Getting Started

Section Contents

- ▶ Introduction
- ▶ System Photo

Important

Read and understand all instructions in this user's manual and the enclosed 2104 temperature control instruction manual before attempting to install or operate system.

Introduction

Congratulations on purchasing the Chromalox microTHERM™ Oil Temperature Control System. This system has been thoroughly engineered, carefully built, and fully tested to assure years of service.

The microTHERM™ Oil can be operated at a maximum temperature of 550°F. Oil temperature is maintained by a microprocessor-based temperature controller which applies heating and cooling as needed.

Electrical and hydraulic components are located in distinctly separate areas in the system to better manage heat buildup and prevent component damage. It is designed to drastically reduce the chance of oil dripping inside the product and provide ease of service and maintenance. Standard casters make it easy to move the system from machine to machine.

Power requirements for the system are 240 or 480 volts, 3 phase, 60 cycle, and 6 to 24 kW. See the system nameplate for the appropriate voltage and wattage ratings.

Oil or other synthetic fluids or mineral based fluids may be used with this product. See section 4 number 1.

The System Photo and Control Panel Illustrations, on the following pages identifies all key components.

Figure 1.1 System Photo (Side View)

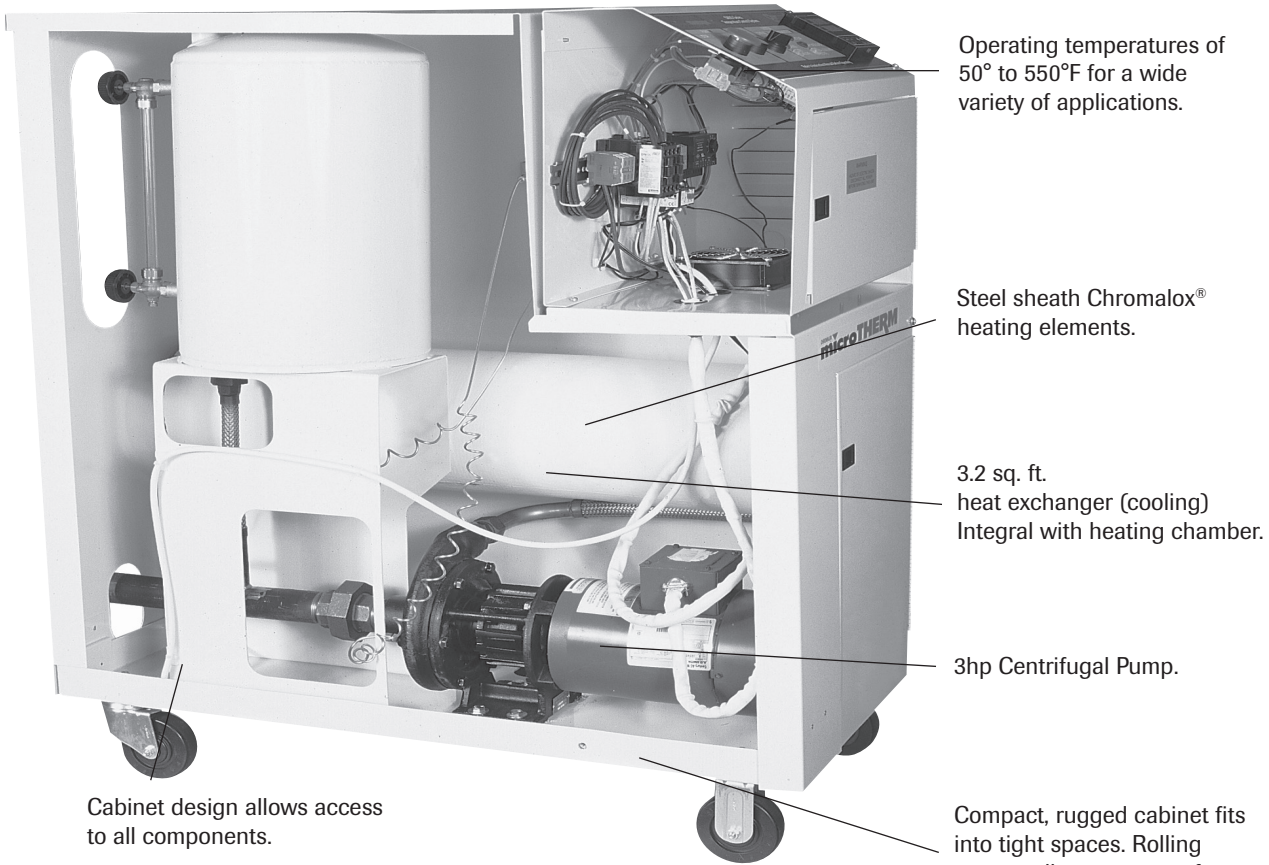

System Photo (Rear View)

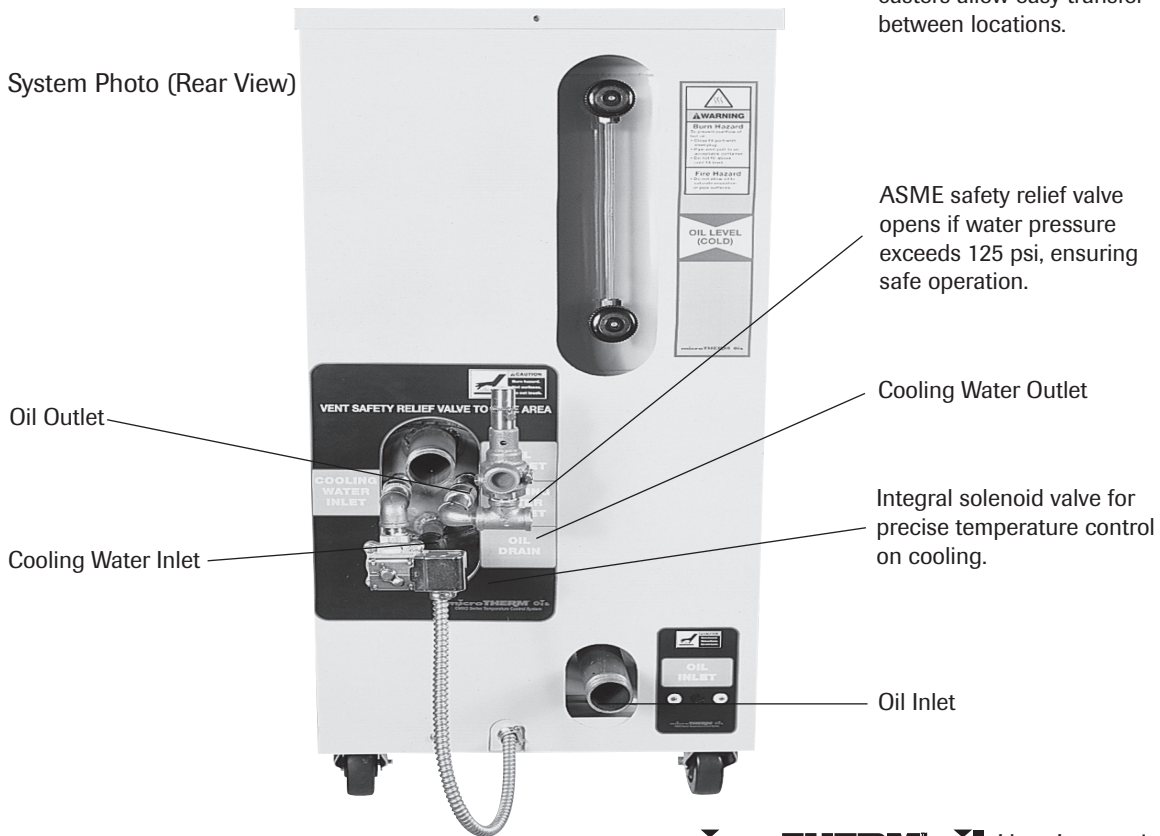
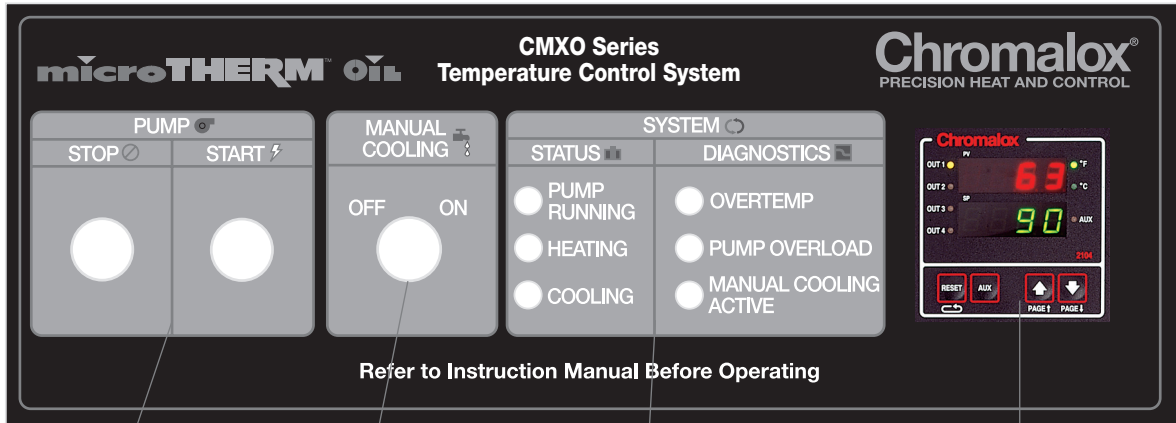

Figure 1.2
Control Panel



Pump
START/STOP
Pushbuttons

Manual Cooling
Switch

Status and Diagnostic
Indicators

Chromalox 2104 Temperature
and Process Controller

Section 2 Installation

- Section Contents**
- ▶ Hydraulic Installation
 - ▶ Electrical Installation

Before Hydraulic Installation

Before proceeding with the installation please take note of the following information:

WARNING

HAZARD OF EXPLOSION, FIRE AND SCALDING BURNS

1. The cooling water feed line must not have any obstructions which could cause buildup in pressure.
 2. When installing system, allow sufficient room to remove the heater element and other serviceable items when necessary.
 3. To avoid excessive pressures, do not connect any valves or obstructions which could prevent free discharge from relief valve in a safe manner. Vent outlet of pressure relief valve to a drain where steam or scalding water will not cause personal injury. Do not allow drain to freeze or corrode shut.
 4. Use only on concrete floor or other nonflamable surface. Use in an open area with at least 1 foot clearance from walls and combustible materials.
-
1. This product is designed to roll over smooth flat floors. Do not roll over uneven floors and on ramps. Do not move while hot or containing fluid.
 2. Reduced diameter fittings may be used down to 1" if they do not reduce flow rate and increase pressure drop significantly.
 3. Use softened water for cooling.
 4. Use and maintain oil filters.

Hydraulic Installation

WARNING

HAZARD OF EXPLOSION, FIRE AND SCALDING BURNS

1. Connect the 1/2" NPT port identified as "COOLING OUTLET" to an open or plant drain that contains no valves or obstructions that could impede discharge. Review the condition of potential hot water or steam going down a plant drain. Verify that local codes and materials are acceptable for this service.
2. This system is for use only with liquid phase heat transfer fluids suitable for a max bulk temperature of 550°F at atmospheric pressure. Use with any other fluids could result in death, personal injury, fire or damage to the equipment.
3. Do not place valves in vent line or allow vent line to become even partially clogged. Vent line on the expansion tank must be piped to a safe area and/or catch drum. Provisions must be taken to allow constant slope on vent to allow draining and to prevent liquids from collecting in the vent pipe. Vent should be periodically checked to verify it is free and clear of all obstructions. Vent piping should be no smaller than connection on the system. Do not place valves in vent line as system must remain vented at all times.
4. Do not overfill expansion tank.
5. Do not allow heat transfer oil to saturate insulation. Failure to comply could result in personal injury or property damage.

Important

Read and understand all instructions in this manual and other manuals shipped with the system prior to installation. All work specified within this instruction sheet should be performed by qualified personnel as required (electrician, plumber or mechanic).

1. System should be mounted on a solid level foundation. Where required, containment area should be provided in case of fluid loss. The system should be installed at the same level or higher than the process to be heated.
2. Before installing, check that all mounting bolts on equipment are tight. These sometimes loosen in shipment.
3. Piping to and from the process should match the piping on the system. If extremely long runs of pipe are to be used, one

Hydraulic Installation

(continued)

size larger than the system connections can be used to minimize pressure drop. Piping should be arranged to be self-supporting and not supported by the heat transfer system. On long runs, isolation from thermal expansion should also be provided. If the above are not taken into consideration, unnecessary stress will be put on the pump and/or piping.

4. Thread sealant and/or gaskets used on process piping should be rated for temperatures and heat transfer fluid to be used. Check with manufacturer for compatibility.
5. The piping of the entire system should be arranged to minimize pockets where air may be trapped. Manual bleed valves must be provided at any location where air may be trapped.
6. Connect the cooling water supply (30 psi to 80 psi) to the unit's 1/2" NPT "WATER SUPPLY/COOLING INLET" port with suitable pipe or hose.

Figure 2.1
Piping

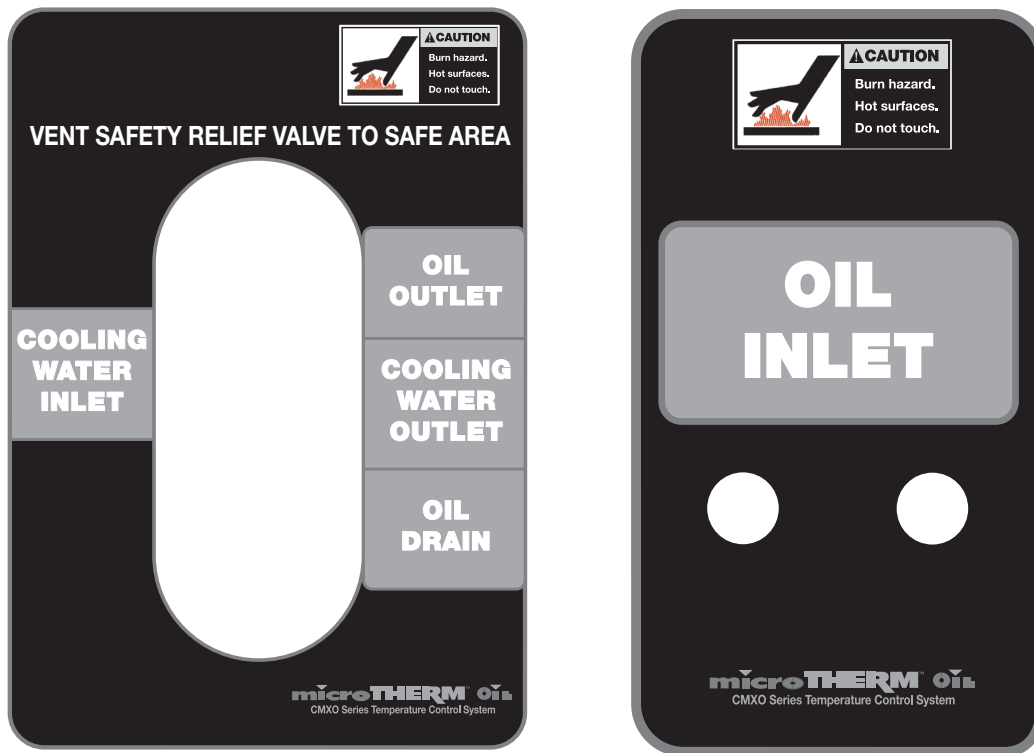
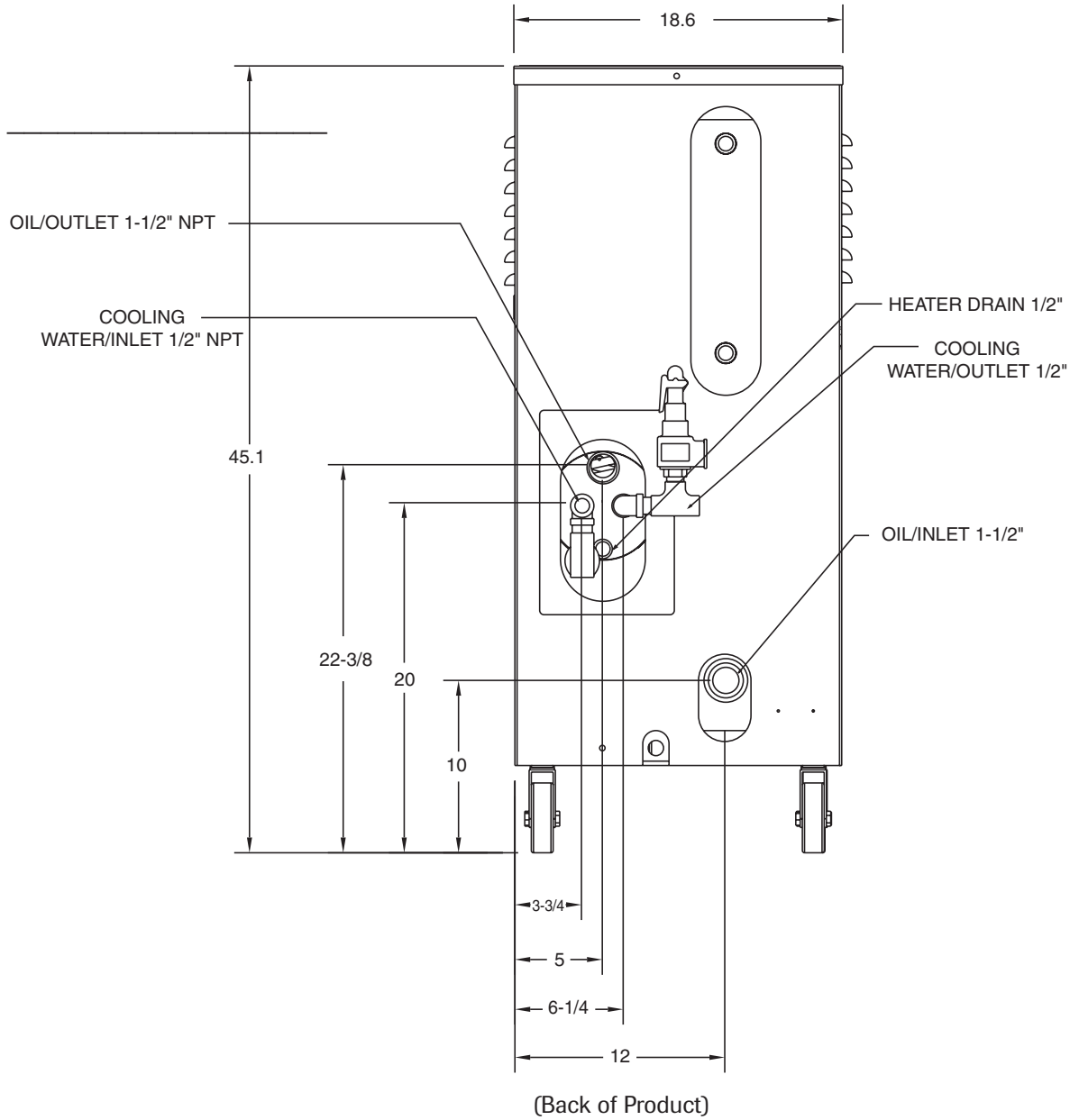

Figure 2.2
Piping Connections



Electrical Installation

WARNING

HAZARD OF ELECTRIC SHOCK

1. Disconnect all power before installing or servicing the heat transfer system. This system must be installed by a qualified person in accordance with National Electric Code, NFPA 70. Failure to comply can result in personal injury or equipment damage.
2. The heat transfer system must be effectively grounded to the grounding means provided in control box in accordance with National Electric Code.

Fusing or other over-current protection must be supplied to the system by the user.

The unit is completely wired when shipped. The only wiring necessary is to the blue colored terminals L1, L2, L3, and the green-and-yellow colored ground. To make these connections:

Figure 2.3
Power Connection Terminals

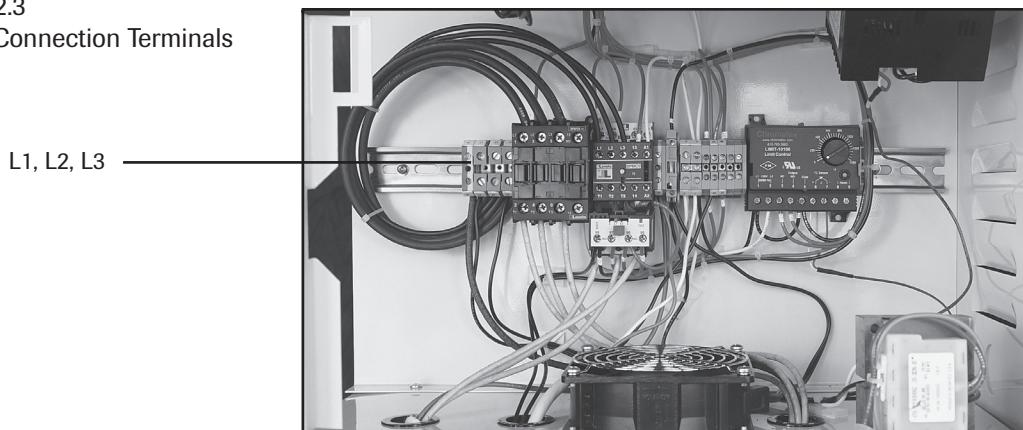

1. Loosen the screw on the front electrical enclosure door to unlock the latch.
2. Open the front electrical enclosure door. Using 90°C wire sized per National and local codes, run each leg of the three phase supply power and ground to the appropriate terminals as shown in Figure 2.3.
3. A separate fused disconnect is required. Locate this fused disconnect near the equipment. Codes may require the location of disconnect in sight of operation standing next to the equipment. Consult applicable codes for details.

4. With power off, check the wiring connections by tugging on the lines. Tighten all terminals in the control area. These can loosen due to vibration in shipping.

Pump Rotation Check

5. Close the front electrical enclosure door. Pull the top cover off of the heat transfer system and locate the pump motor.
6. Press the **START** and **STOP** buttons in quick succession.

Watch the rotation on the pump motor to insure it matches the label.

7. If rotation is incorrect, disconnect power to the system and swap any two of the supply lines. Repeat rotation check.

WARNING

ELECTRIC SHOCK HAZARD

Close the front electrical enclosure door and retighten the locking screw. This must be done to limit access to high voltage components. Failure to comply result in personal injury or equipment damage.

Control Voltage Fusing

Figure 2.4 contains a 120V fuse for the control circuitry. This fuse protects the control transformer and circuitry.

1. Should the fuse blow, an indicator will light on the terminal block.
2. Disconnect power from the system.
3. Determine the cause of the blown fuse.
4. Replace with an equivalent fuse.
5. Reconnect power.

Figure 2.4

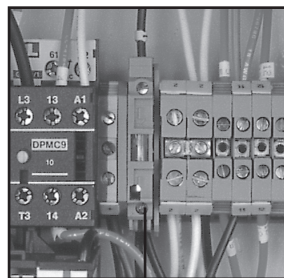

Control Voltage Fuse

Section 3

Temperature Control Operations

- ▶ Control Panel
- ▶ Temperature Controller Operation

Figure 3.1
Control Panel Layout

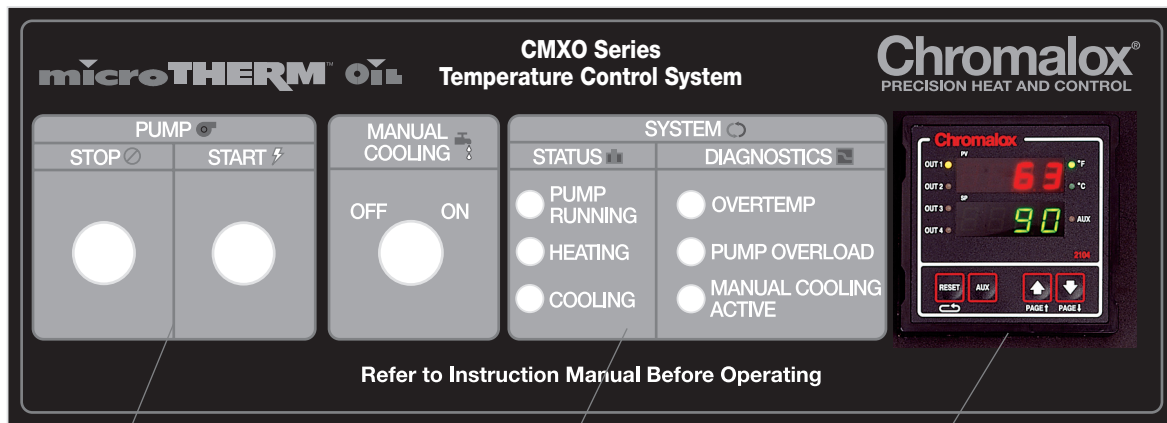
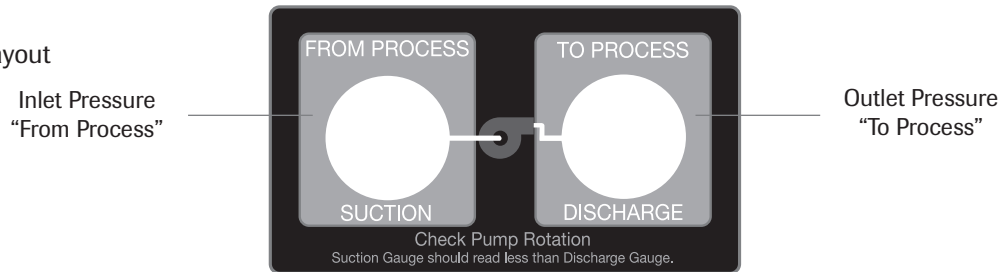

START/STOP Pushbuttons

Press **START** to start the pump.
Indicator will illuminate while pump is running. Press **STOP** to stop the pump.

Status and Diagnostic Indicators

System shuts down if any red diagnostic indicator is illuminated.

- ☀ **Pump Overload:**
 - Pump has drawn too much current.
- ☀ **Over Temperature:**
 - System temperature has exceeded 600°F.
- ☀ **Pump Running**
- ☀ **Heating**
- ☀ **Cooling**
- ☀ **Manual Cooling:**
 - If manual cooling is on, heaters shut off and water cooling is on. Normally this is off and the temperature controller determines when to heat or cool.

Temperature Controller

Top Display reads current system outlet temperature.

Bottom Display reads setpoint temperature.

Press ▲ to increase setpoint temperature.

Press ▼ to decrease setpoint temperature.

- ☀ **OUT 1**
 - Heat is being applied.
- ☀ **OUT 2**
 - Cooling is being applied.
- ☀ **AUX**
 - Indicates system is in Standby.

Temperature Controller Operation

The Chromalox® 2104 1/4 DIN temperature controller is a high-performance, single-loop controller. The 2104 controller has two control outputs for heating and cooling that can be configured separately and provide flexible temperature control. A dual digital display of current process temperature and setpoint temperature make the system easy to understand and operate.

The 2104 controller has extended capabilities and functions for more technically advanced applications. To learn more about how these controller capabilities may be used, consult the enclosed 2104 Controller Technical Manual, part number, 0037-75276.

Figure 3.2
Controller Displays

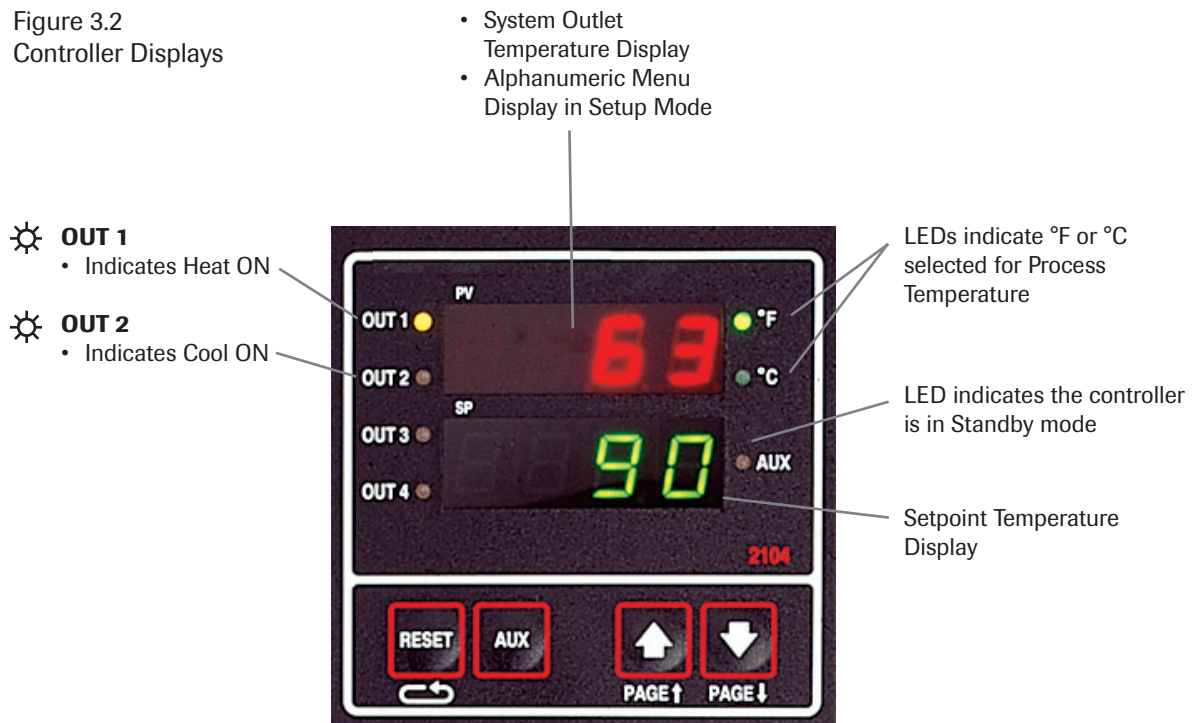

PAGE/MENU Setup

All control parameters, selections and calibration procedures for the temperature controller are accomplished through simple MENU selections. These MENU selections are organized into PAGES.

The Display PAGE (DISP) allows you to view the status of the controller. The Control Page (CTRL) allows you to change the control setpoint and security lock.

Figure 3.3
Controller
PAGE/MENU
Selections

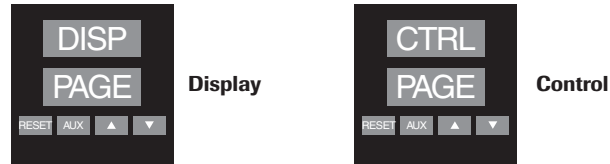

Accessing the Security Lock or Setpoint MENU is accomplished by entering the Setup Mode, then selecting the Control PAGE and the desired MENU.

To enter Setup Mode:

Hold down the **RESET** pushbutton for longer than 3 seconds.

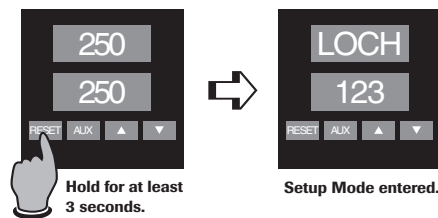

To change the PAGE:

Press and hold the **RESET** pushbutton while pressing the **▲** or **▼** pushbutton. the upper display will increment (or decrement) through the PAGEs, and PAGE will be displayed in the lower display.

After reaching the CTRL PAGE, press RESET to move through the MENUs. The alpha cue for the MENU will appear on the upper display, and the current value will appear in the lower display.

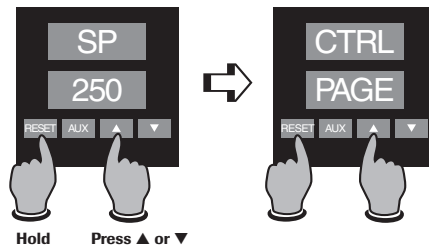

To change a MENU value:

After the MENU is selected and displayed, use the ▲ and ▼ pushbuttons to change the value. For large adjustments (for example, 100 to 200), hold the pushbutton pressed and the display will change more quickly.

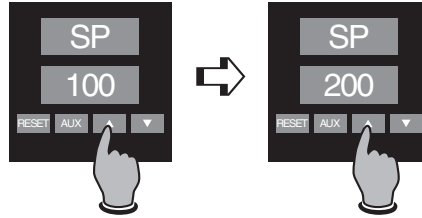

To return to Operating Mode:

Press and hold **RESET** for more than 3 seconds. The controller will automatically return to operating mode after 10 minutes of no pushbutton activity.

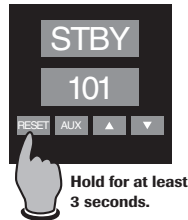

Security Code

Every parameter or selection in the 2104 controller's setup PAGES has an identifying MENU. The MENUs are accessible only if the correct Security Code is entered. This allows you to set the Security level that is appropriate for your operating environment, prohibiting unauthorized access to or accidental changing of control parameters.

The microTHERM™ system is factory preset to security code 123. To adjust any of the controller's setup parameters, the security code must be set to 458.

The Security Code is entered on the Control PAGE CTRL, at the MENU LOCH. This code determines which MENUs may be adjusted.

To access and enter the Security Code:

1. Press and hold **RESET** for more than 3 seconds to enter Setup Mode. Security Lock is the first menu that will appear (LOCH).
2. To change the Security Code, press **▲** or **▼** until the correct security code is displayed (458 to change controller setup).



3. Reference the factory preset MENU settings (Figure 8.2, page 35), when replacing the controller or if the settings have been changed.



Control Page

Menu	Description	Available Settings	Factory Settings	Security
LOCH	Security Lock	0 to 9999	123	A
SP	Setpoint	Instrument sensor span	32°F	B

Section 4 Operation

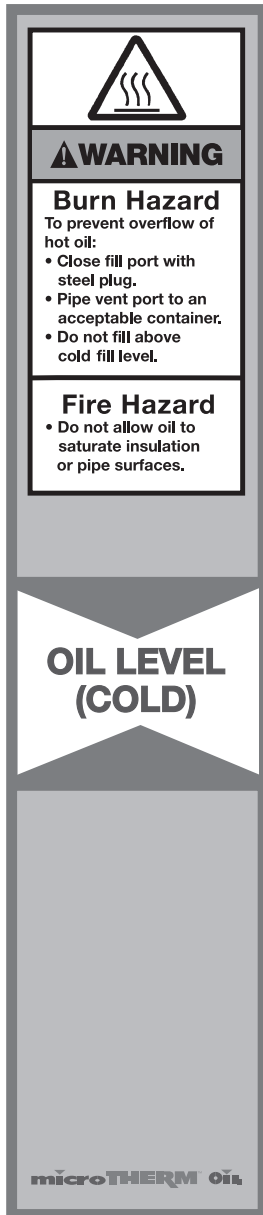

CAUTION

Damage to the pump and/or heater may occur if the system is operated without fluid. Fill system prior to starting. Operate in 105°F or less surrounding temperature.

Note:

Read and understand instructions on the temperature control before operating the system.

1. Check to ensure the fluid is the same as or compatible with the fluid with which the system was factory pretested. (Mobiltherm 603)

Important

For disposal see fluid manufacturer's recommendations.

2. The system is filled with heat transfer fluid directly from the 55 gallon drum by simply connecting a hose from the expansion tank (located on the top of the system) to the drum. Fill expansion tank until sight glass indicates it is approximately $\frac{1}{3}$ full.
3. The overheat temperature control is located inside the control panel. Setpoint should be adjusted 50°F higher than the indicating temperature control. **WARNING: Never exceed a setting of 600°F on the overtemperature control.**
4. Close control box door and turn circuit breaker on. Start pump – do not be alarmed if the pump is noisy during the initial start-up operation, this is due to air in the system.
5. Bleed out all air by opening bleeder valves in the customer's piping. The pump should become quiet.

CAUTION: During the initial start-up operation, the liquid level in the expansion tank must be checked continually. This level should not exceed the three-quarter mark on the glass nor drop below the one-quarter mark.

Note: If abnormal fluid expansion is detected, this is probably due to a pocket of air or steam still present in the system. Check all bleed valves. If problem continues, de-energize pump and check bleed valves.

6. Set indicating or controlling thermostat at 220°F, which will energize the heater. The heater is interlocked with the pump motor starter so that, in the event of motor failure, the heating elements will shut off automatically.

7. Run the system until 220°F is reached. Periodically open the bleed valves in the customer's piping to remove air from the system. At 220°F any moisture that has been trapped in the system will flash into steam as it goes through the heater and can be bled out through the bleed valves.
8. Excessive moisture and air in the system will cause the heat transfer liquid to back up into the expansion tank, thus evacuating the piping or process. If this happens, shut the system down, bleed off the steam and air allowing the liquid to return. If problem persists, drain the system and recharge with new moisture-free heat transfer liquid.
9. After the system is completely free of air pockets and moisture, set control thermostat at the desired temperature. Never set temperature control above 550°F.
10. For detailed operation and tuning procedure on the temperature control, consult instruction manual on the temperature control.
Note: Consult Service Manual PQ410 for additional aid to help start-up and to service Chromalox Heat Transfer Systems.

 **WARNING**

BURN HAZARD

Operating systems at temperatures above 140°F will create surface temperatures on pipes that can cause burns. Precautions should be taken to prevent operator contact with hot pipes. Also, bleed valves should be locked down to prevent release of hot fluid.



Note:

This is a PID type controller and cycling of the heat and cool can be expected below and above setpoint.

11. For system shutdown, lower the setpoint to 90°F or lower (see Section 3). Allow the system to cool to this temperature.
12. Press  to de-energize the pump and disable the system.
13. Disconnect power to the unit.

 **WARNING**

ELECTRIC SHOCK AND BURN HAZARD

Do not leave system unattended in a **HOT** electrical condition.
Do not leave system unattended while **HOT**.

Manual Cooling

If manual cooling is on, heaters will be off and water cooling will be on. Normally, manual cooling is off and the temperature controller determines when to heat or cool. Manual cooling is optional.

To use manual cooling:

1. Turn manual cooling on and observe temperature.
2. Optional. If at a safe temperature, you may stop the pump until you are ready to run again. Important, even if the pump is off, cooling water will run to the heater as long as manual cooling is on and there is electricity to the product.
3. When ready, turn pump on and turn manual cooling off. The temperature controller will heat or cool to the desired temperature. Important, even if electricity is turned off to the product, when electricity is turned on, the temperature controller will go back to the previous temperature before manual cooling. If this is not desired, it is best to use the temperature controller instead of manual cooling.

Section 5 Diagnostics

- Section Contents**
- ▶ Pump Overload
 - ▶ Over Temperature

Figure 5.1
Diagnostic Indicators

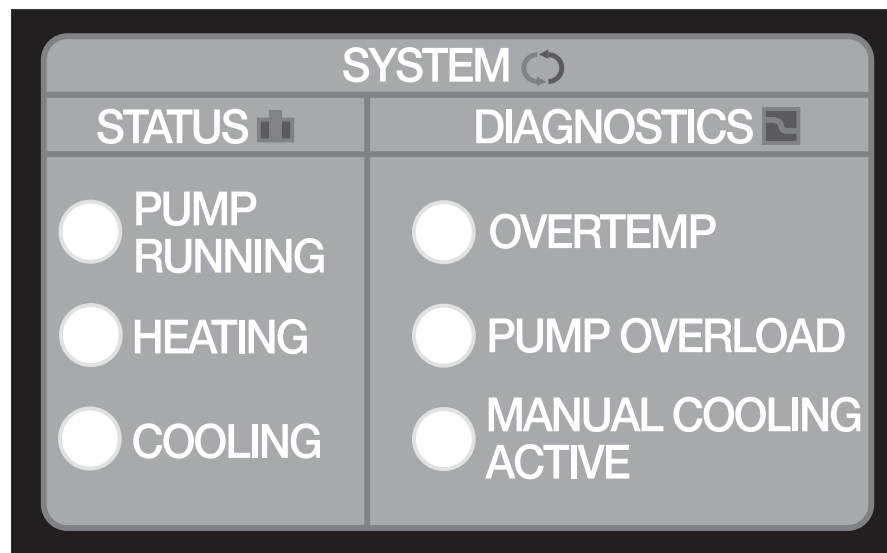

Diagnostic Functions All red light diagnostic functions will shut down the system and require the operator to remedy the problem before it can be restarted.

Pump Overload Indicator

The Pump Overload Indicator will illuminate when the pump draws too much current. Low line voltage, single phase power input, and a seized pump motor are all possible causes for pump overload.

Figure 5.2
Pump Reset Switch

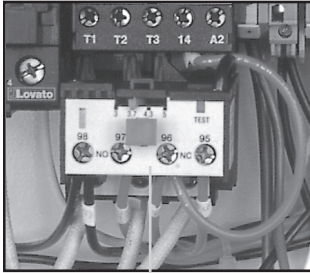

Pump Reset Switch

WARNING

ELECTRIC SHOCK HAZARD

If the Pump Overload Indicator is illuminated, disconnect all power and piping to the system. Failure to do so could result in personal injury or equipment damage.

After the system power is disconnected, solve the electrical current problem. To put the pump back on-line, open the front electrical enclosure and press the pump reset switch. See Figure 5.2.

WARNING

ELECTRIC SHOCK HAZARD

Close the front electrical enclosure door and retighten the locking screw. This must be done to limit access to high voltage components. Failure to comply could result in personal injury or equipment damage.

Over Temperature Controller

If the system temperature exceeds 600°F (315°C), the Over Temperature Indicator will illuminate. When the system temperature drops below 550°F, press reset on the over temperature controller inside the panel. Close door and retighten the screw. The controller will not reset until the temperature is below 600°F. Or remove electricity to the product and the over temperature controller will reset after temperature is below 600°F.

Figure 5.3
Over Temperature Controller
Reset Switch



Over Temperature Controller
Reset Switch

Section 6 Maintenance

Section Contents

- ▶ Take Out Of Service
- ▶ Heater Removal/Replacement
- ▶ Pump Removal/Replacement

WARNING

ELECTRIC SHOCK AND BURN HAZARD

Disconnect all power before servicing or performing maintenance to the system. Do not attempt to service system while it is operating or while hot.

Failure to comply can result in:

- a. Electric shock.
- b. Burns from hot heating elements, piping, and hot oil or water.
- c. Injury from operating or rotating pump and motor.

Maintenance is to be performed by qualified personnel only. Thoroughly read and understand these instructions. Consult the factory if you have any questions.

Take Out Of Service

To take the unit out of service, the following steps must be done in sequence:

1. Set the temperature controller setpoint to 90°F or lower. Allow to cool.
2. Turn off power to the unit. The controller will turn off.
3. Turn off the water supply to the unit.
4. Disconnect electrical supply to the unit.
5. Drain the system.
6. If it is exposed to freezing temperatures while out of service, remove water by blowing air through cooling pipe. You will need to open the cooling valve by turning on manual cooling or removing it.

Heater Removal/Replacement

WARNING

ELECTRIC SHOCK HAZARD

Disconnect all power to system before servicing. Failure to comply can result in personal injury or equipment damage.

BURN HAZARD

Never service system while hot. Allow system to cool to room temperature before servicing.

1. Check that power is disconnected from the system and remove wiring to heater.
2. Disconnect thermocouple from control cabinet.
3. Drain heater and pump.
4. Remove bolts on heater and undo fittings on pipe. Remove heater through the front door.
5. Install new heater and retighten all bolts and fittings.
6. Put all sheet metal back in place and retighten screws.
7. Refill system and follow operation procedure in Section 4.

LEAKS

1. Leaks should be minimized.
2. **CAUTION: Hazard of Fire.** Some heat transfer fluids are flammable and if allowed to leak on hot pipes or in fibrous thermal insulation, a fire hazard can be created.
3. Disassemble, clean and reseal the connections using high temperature sealant. (Do not use TFE or other tape.) Sealants are to be rated for temperatures and fluids used in the system.

WARNING

ELECTRIC SHOCK HAZARD

Close the front electrical enclosure door and retighten the locking screw. This must be done to limit access to high voltage components. Failure to comply could result in personal injury or equipment damage.

Pump Removal/Replacement

WARNING

ELECTRIC SHOCK HAZARD

Disconnect all power to system before servicing. Failure to comply can result in personal injury or equipment damage.

BURN HAZARD

Never service system while hot. Allow system to cool to room temperature before servicing.

1. If pump requires service, drain system and remove top and side panels.
2. Pump/motor can be removed from the system as an assembly for service.
3. Disconnect piping at unions on inlet and outlet piping leading to the pump.
4. Remove four bolts which hold the pump/motor base to the base of the system.
5. After verifying power is disconnected remove conduit and wiring from the motor.
6. Lift out pump/motor assembly.
7. Service pump per pump manufacturers instructions.
8. If replacing the pump, be sure to remove piping from old pump casing before discarding. Clean thread on pipe and thread into new pump casing using high temperature oil resistant thread sealant. **DO NOT USE TFE OR OTHER TAPE SEALANTS.**
9. Install new pump in system reconnect piping.
10. Reconnect wiring and check rotation as indicated in “INSTALLATION” section.

WARNING

ELECTRIC SHOCK HAZARD

Close the front electrical enclosure door and retighten the locking screw. This must be done to limit access to high voltage components. Failure to comply could result in personal injury or equipment damage.

Figure 6.1 Electrical Schematic, Heat, Cool

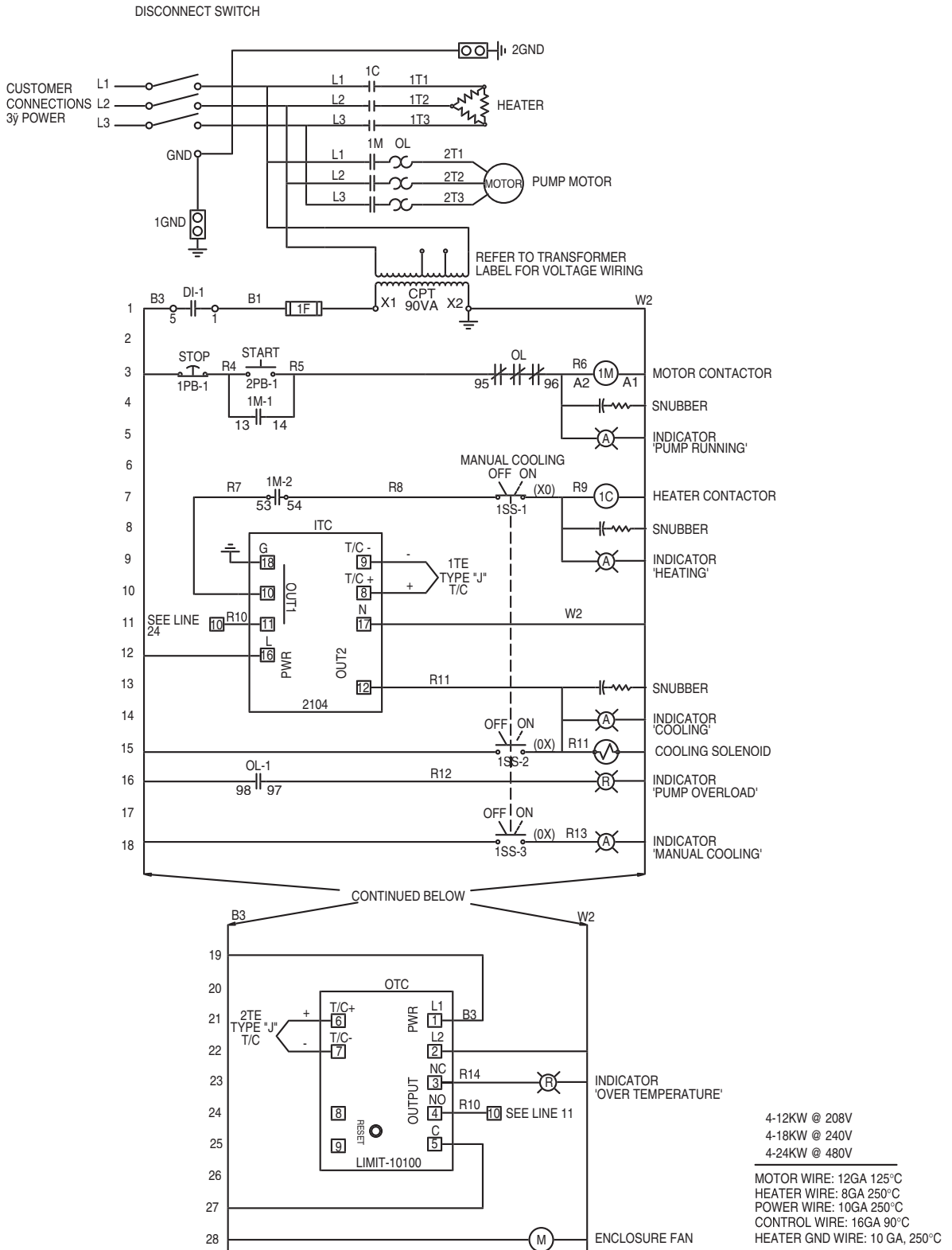
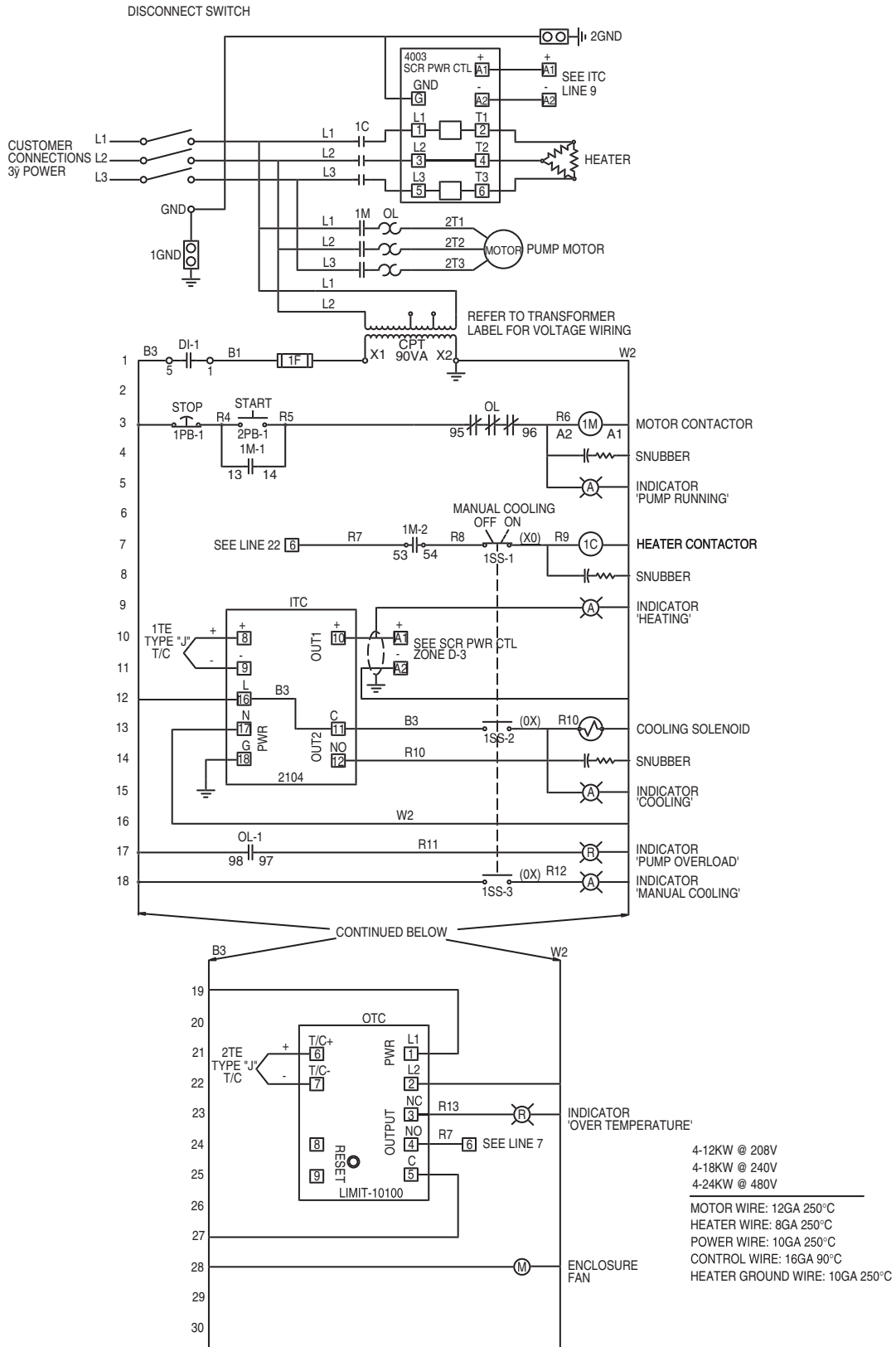

Figure 6.2 Electrical Schematic, Heat, Cool, SCR



Section 7 Troubleshooting

Troubleshooting Guide—*For qualified personnel only. See warnings in earlier sections.*

Symptom	Probable Cause	Correction
Unit will not start, control display does not light.	<ol style="list-style-type: none"> 1. Unit not wired correctly. 2. Disconnect switch OFF. 3. Blown fuse. 4. Wrong voltage. 	<ol style="list-style-type: none"> 1. Check wiring. 2. Turn disconnect ON. 3. Check customer disconnect fuses and 120V fuse on terminal block (blown fuse indicator will light if fuse is blown). 4. Check supply voltage and unit's rated voltage.
Control display lights, unit will not start.	<ol style="list-style-type: none"> 1. Pump motor overload. 2. System above temperature limit of 600°F. 	<ol style="list-style-type: none"> 1. See Section 5. Determine problem and press pump reset. 2. Allow unit to cool below 550°F and press reset on over temperature controller inside the panel. See Section 5.
Unit stops while running. restart.	<ol style="list-style-type: none"> 1. Pump motor overload. 2. System exceeds temperature limit of 600°F. 	<ol style="list-style-type: none"> 1. Determine problem, press pump reset, and restart. 2. Allow unit to cool below 550°F, press reset on over temperature controller inside the panel, and See Section 5.

continued →

Troubleshooting Guide—For qualified personnel only. See warnings in earlier sections.

Symptom	Probable Cause	Correction
Pump Overload Indicator illuminated.	1. Pump motor overload.	1. See Section 5. Determine problem and press pump reset button.
Over Temperature Indicator illuminated	1. System above temperature limit of 600°F.	1. Allow unit to cool below 550°F and press reset on over temperature controller inside the panel. See Section 5.
Unit runs but fails to pump.	1. Incoming phase reversed on pump motor.	1. Swap any two legs on the incoming power.
Unit will not heat to setpoint.	1. Cooling valve stuck open. 2. Heater element failure. 3. Heater output insufficient. 4. Controller needs to be tuned. 5. Manual cooling on.	1. Check for cooling water flow during heat cycle. 2. Check current at heater contactor during heating. 3. Excessive losses in process or incorrectly sized unit for application. 4. Check factory MENU settings, Section 3 of this manual. Refer to 2104 Controller Technical Manual, page 35, for further information. 5. Turn manual cooling off.
Unit will not cool to setpoint.	1. Inadequate cooling water flow. 2. Cooling outlet obstructed. 3. Heater contactor fused closed. 4. Controller needs to be tuned.	1. Open cooling water supply line more and assure adequate pressure. 2. Check cooling outlet for obstructions. 3. Check voltage across contactor during cooling cycle. 4. Check factory MENU settings, Section 3 of this manual. Refer to 2104 Controller Technical manual, page 35, for further information.

If you continue to have problems with the system after review of the above issues, please contact Chromalox Product Service at 800-443-2640.

Section 8 Specifications

Pump Size (HP)	Nominal Flow (gpm)	Oil Connections (inches dia.)	Water (inches dia.)	Approximate Dimensions (inches)
3	30	1 1/2 NPT	1/2 NPT	45 height 38 depth 19 width

Figure 8.1
Pump Capacity
(As reported by pump manufacturer on Model HTO-80; Size 1.5 x 1.25; Speed 3450 RPM; S.G. (.85)).

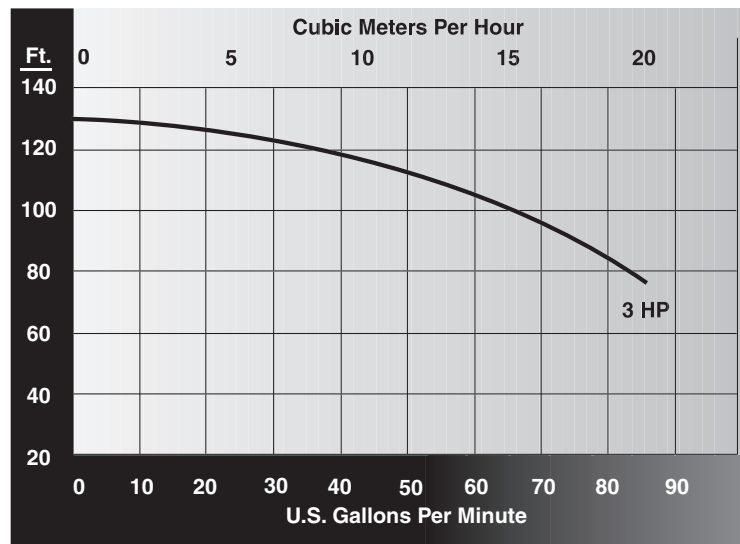
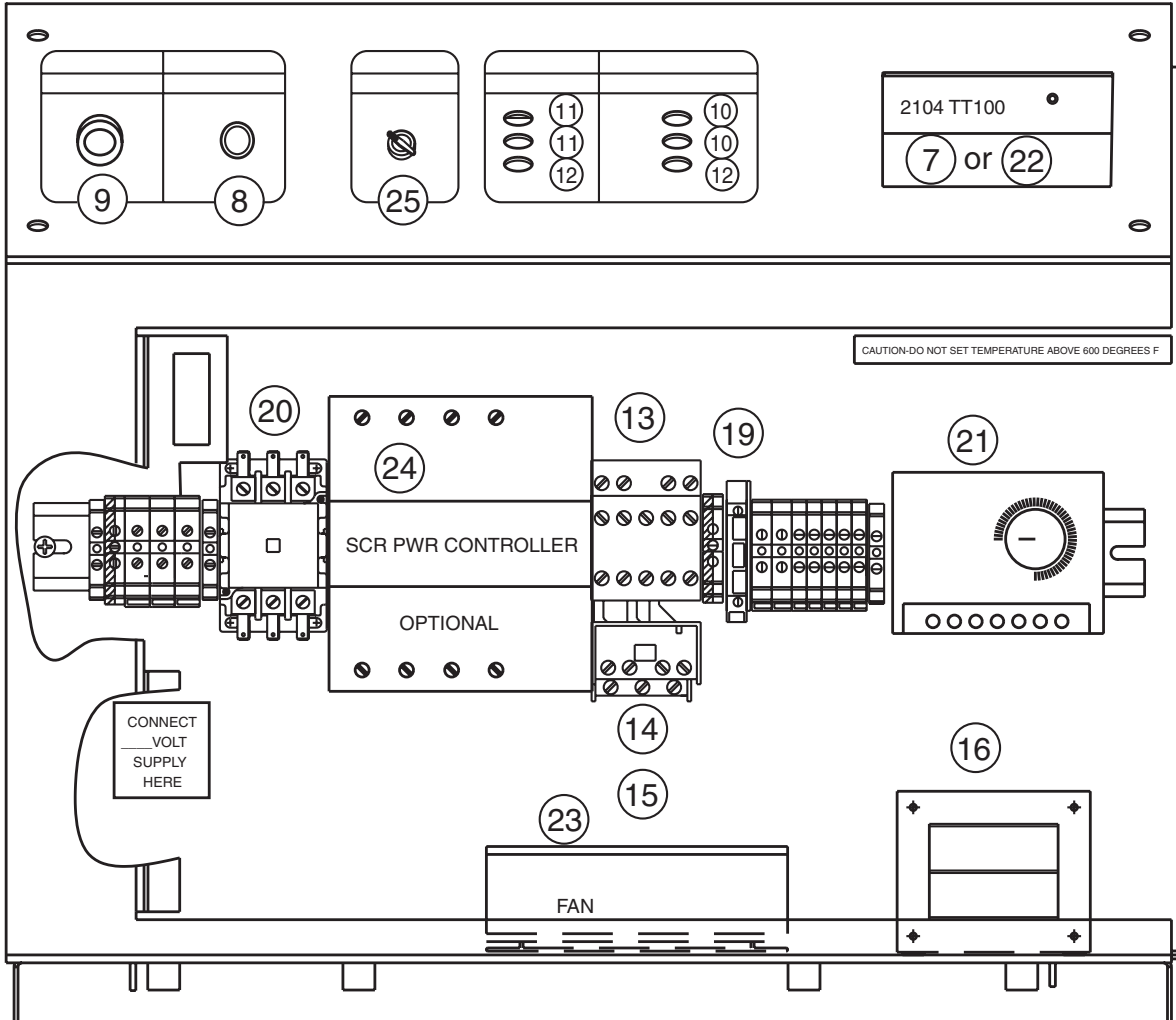

Figure 8.2
Power & Capacity Information

kW	BTU's Per Hour	Nominal Amps*		Volume (Gal.)	Heat Exchanger Surface Area (Ft.)
		240V	480V		
4	15,354	21.4	10.7	6.1	3.2
6	20,472	26.2	13.1	6.1	3.2
9	30,708	33.4	16.7	6.1	3.2
12	40,944	40.7	20.3	6.1	3.2
18	61,416	54.7	27.5	6.1	3.2
24	81,888		34.6	6.1	3.2

*Total per leg based on 3 phase, 60 cycle power with heater at rated voltage, motor at rated output, and control transformer at full load. Measured value may vary depending on conditions.

Figure 8.3
 Replacement Parts
 Identification



Replacement Heaters

microTHERM^{oil}		Replacement Parts
kW	Voltage	Heater
6	240	052-305096-001
	480	052-305096-002
9	240	052-305096-007
	480	052-305096-008
12	240	052-305096-005
	480	052-305096-006
18	240	052-305096-003
	480	052-305096-004
24	480	052-305096-001

Replacement Parts Common to All Models

Identification #	Part Name	Part #
1	3 HP Pump & Motor 230V/460V	226-304843-002
	Pump Rebuild Kit (Seal, Gasket, etc.)	251-121946-032
2	Solenoid Valve	344-072237-021
3	Safety Relief Valve	344-300032-103
4	Pressure Gauge 0-100psig	130-118661-037
5	Pressure Gauge 30" Vac - 30 psig	130-118661-038
6	Thermocouple	
	Process T/C	309-304460-036
	Overtemp T/C	300-304460-012
7	Temperature Controller	309-123617-101
8	Push Button, Start	292-304687-003
9	Push Button, Stop	292-304687-004
10	Light, Red	213-122066-041
11	Light, Amber	213-122066-042
12	Light, Green	213-122066-043
13	Motor Contactor 240/480V	072-123534-065
14	Auxillary Motor Contact Block	071-122886-055
15	Motor Thermal Overload 240V	359-122078-097
15	Motor Thermal Overload 480V	359-122078-096
16	Transformer 240/480V	315-303786-001
17	Caster, Swival	375-123425-006
18	Caster, Rigid	375-123425-007
19	Control Voltage Fuse	303-123432-024
20	Heater Contactor	072-304551-008
21	Over Temperature Controller	381-700400-297
22	Temperature Controller with digital communications - Call 1-888-996-9258	
23	Fan	112-121869-005
24	SCR	300-400360-610
25	On/Off Cooling Switch	292-304687-002

Section 9

Index

Alarm

- Latching 14
- Overtemperature 11, 14, 27
- Relay Action 14

Cabinet 2

- Contactors 23, 30
- Control Output #1 (Heat) 10, 11
- Control Output #2 (Cool) 10, 11
- Control Setpoint 10, 11, 14, 15, 16, 26, 30
- Control Voltage Fusing 9, 30
- Controller
 - Temperature Controller 1-3, 10, 11, 12, 17, 19, 30
- Cooling, Control 10, 11, 17
- Cooling, Manual 17
- Cooling Solenoid 23 See Valve, Cooling
- Cooling Water Valve 2, 26, 27

Diagnostic Functions 18

- Diagnostic Indicators 3, 10, 18
 - Over Temperature 10, 14, 18, 19, 23, 27
 - Pump Overload 10, 18, 19, 27
- Display, Control 11, 26

Electrical Installation 8

Fusing 8, 9

- Control Voltage 9, 30

Hazard 4, 5, 8, 9, 15, 16, 19, 20, 21, 22

- Heater 4, 15, 16, 17, 20, 21, 27, 28, 30, 31
 - Removal/Replacement 20, 21

Indicators

- Cooling 10, 23
- Diagnostic 10, 18
- Heating 10, 23
- Overtemp 10, 14, 18, 19, 23, 27
- Pump Overload 10, 18, 19, 27

kW 28

Leaks 21

Manual Cooling 10, 17

MENU Selections 12

- Control 12, 13, 14
- Display 11, 12
- Setup 12

MENU Value 13

Motor 6, 9, 15, 19, 20, 22, 23, 26, 27, 30

Motor Contactor 23, 30

Motor Control 10, 19

Operating Mode 13

Operating Temperature 2

Output Relay #3 14

Output Relay #4 14

Overtemperature Indicator 10, 14, 18, 19, 23, 27

Power Requirements 1, 28

Pressure Gauges 30

Process Temperature 11, 14, 15, 16, 19

Pump 2, 3, 6, 9, 10, 15-22, 26, 27, 28, 30, 31

- Pump Indicator Light 19, 23

- Removal/Replacement 20, 21

- Rotation Check 9

Pump Capacity 28

Pump 9, 15, 19, 20, 22, 23, 26, 27

Pump Reset Switch 19, 26

Replacement Parts 29, 30

Schematic, Electrical 23, 24

Safety Relief Valve 2, 4, 30

Security Code 13, 14

- Access 2, 9, 12, 13, 14, 19

- Change 2, 12, 13, 14, 28

Security Lock 12, 14

Service 20, 30

Setpoint 10, 11, 12, 14, 15, 16, 20, 27

- Change 10, 14, 27

- Control 10, 11, 14, 15, 16, 26, 30

- Temperature 1-3, 5, 6, 10-12, 14-22, 26, 27, 30

Setup Mode 11, 12

Shutdown 16

Solenoid Valve 2, 30

Specifications 28

Switch

- Pump Reset 19

Troubleshooting 26

Valve

- Cooling 1, 2, 4-6, 10, 11, 17, 20, 26, 27, 30

- Safety Relief 2, 4, 30

- Solenoid 2, 30

Vent 5

Wiring Diagram

- Heat, Cool 23

- Heat, Cool, SCR 24

