



XC90

Section	Group	Weight(Kg/Pounds)	Year	Month
3	39		2004	04

XC90 2003, XC90 2004, XC90 2005, XC90 2006, XC90 2007, XC90 2008, XC90 2009, XC90 2010

Replaces issue: 2002 05

Installation instructions, accessories - Subwoofer

Volvo Car Corporation Göteborg, Sweden



Required tools

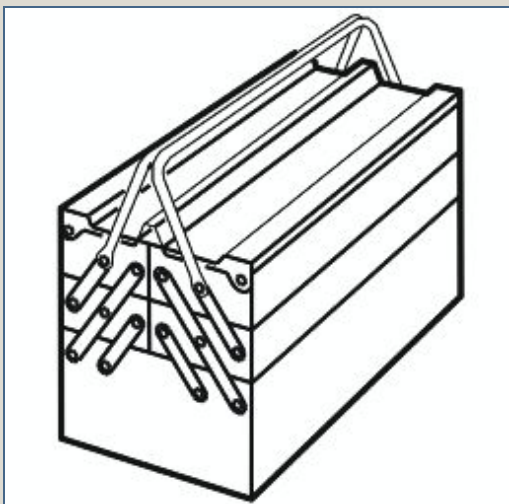

A0000162

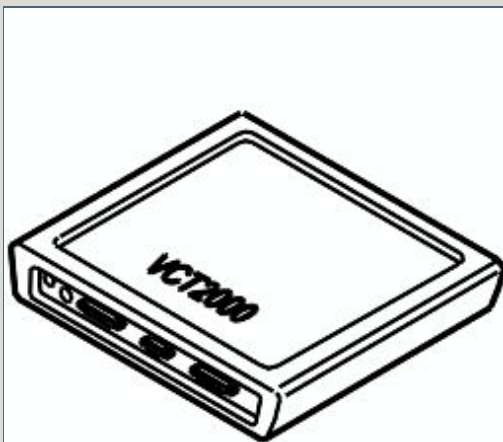

A0801178

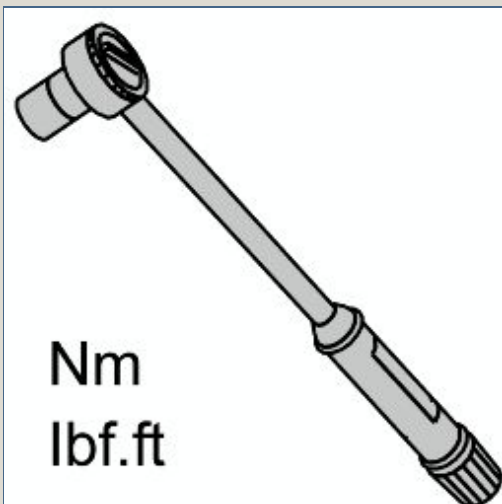

Nm
lbf.ft

A0000161

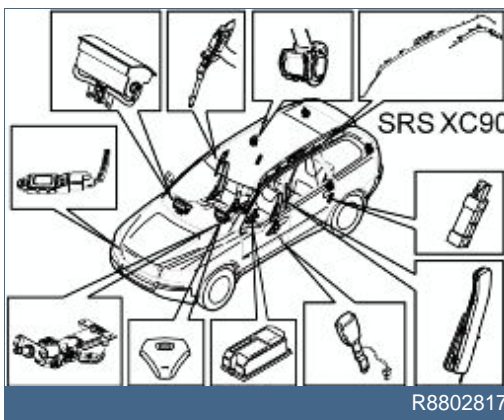

R8802817

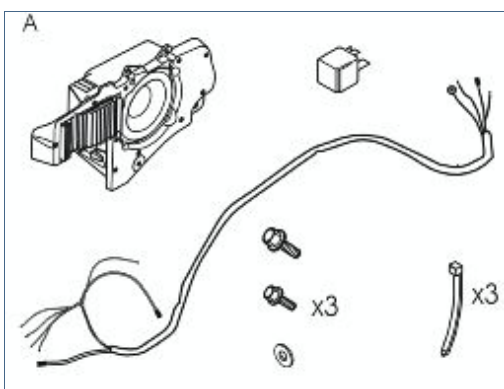

R3903989

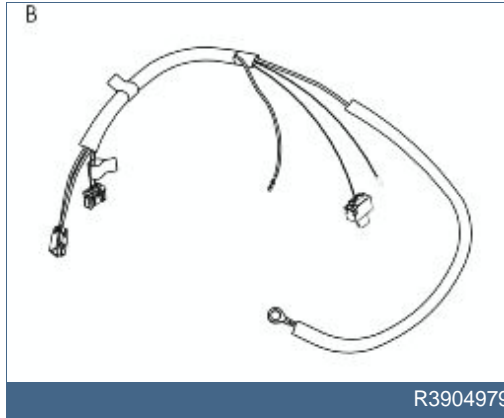

Any comments on this publication? Please contact your nearest dealer. Thank you!

Publication no: MA 9162298, Issue: 2004-04
Comments:.....
From:.....
Address:.....
Telephone no:.....
Telefax:.....



INTRODUCTION

- **NOTE! Read through the whole installation instruction before starting the work.**
- The front page gives the date of this edition and the edition it replaces
- The second page shows the tools needed for the installation and the contents of the installation kit
- The illustrations display the procedure in order of operation. The order of operation is repeated in the text section
- Cut out the text page in order to follow the illustrations and text at the same time.

Cars equipped with SRS/SIPS (Airbag)

Warning!

Extra care must be taken when working on cars equipped with SRS/SIPS air bags. This is important to prevent:

1. Personal injury
2. Damage to or malfunction of the SRS/SIPS system.

Work on the SRS/SIPS systems or related components must always be carried out by an authorised Volvo workshop.

Is the car equipped with SRS (supplemental restraint system)?

Cars equipped with a driver's airbag have the letters "SRS" imprinted on the centre panel of the steering wheel. Cars equipped with driver's and passenger airbags are marked with "SRS" on both the steering wheel centre panel and also on the dashboard close to the airbag.

If the car is equipped with SIPS (side impact protection system) a "SIPS" decal is marked on both the front seats.

Cars equipped with inflatable curtains have the marking "SRS" on one of the panels along the posts on the inside of the car.

Cars equipped with SRS (supplemental restraint system) also have an "SRS" decal on the front windscreen.

Do not damage the SRS wiring!

Do not trap, chafe, pierce or damage the SRS wiring. SRS wiring has orange casing and/or is plaited.

Steering and front suspension

The contact reel in the SRS system can easily be damaged when working on the steering wheel, steering shaft or steering gear. Refer to the SRS (supplemental restraint system) Service Manual or service instructions in VIDA for information on carrying out such work. This is to prevent damage.

SRS warning lamp

If the SRS warning lamp lights after repairs have been carried out, take the car to an authorised Volvo workshop.

SRS collision sensor control module

S60 / V70 (00-) / S80 / XC90

The collision sensor control module is located on the tunnel under the centre console, in front of the parking brake.



CAUTION!

The air bag inflation areas must not be obstructed. Never place any objects, such as upholstery or accessories, within these areas. The panels must be able to open in the correct manner at the right time, otherwise there is an increased risk of personal injury in the event of a collision.

CAUTION!

The ignition must be in position "0" and the key removed from the ignition switch if any connector in the SRS system is to be unplugged. Then wait at least one minute and disconnect the battery negative lead before unplugging any of the connectors. When work is completed, the ignition key must be turned to position "II" before reconnecting the battery negative lead.

Subwoofer

Note!

This accessory requires software unique to the car

Note!

Points 4 - 10, 12, 21 - 31 and 38 only apply to cars up to and including model year -2004 (CH -133999)

Points 32 - 37 and 39 only apply to cars from model year 2005- (CH 134000-).



1

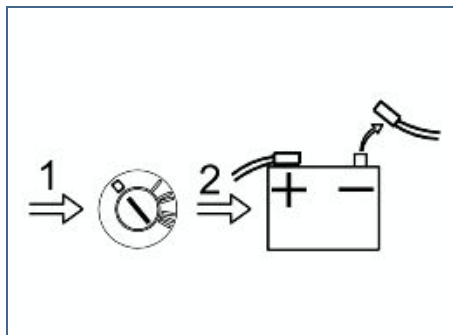

A8800136

Preparatory work

- Move the left front seat as far forward as possible
- Turn the ignition key to position 0
- Disconnect the battery negative lead.

Note!

Wait at least five minutes before disassembling the connectors or removing other electrical equipment

2A

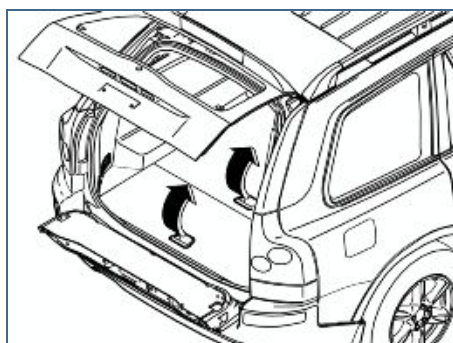

R8902691

Preparatory work

Illustration A

Applies to cars with two rows of seats

- Fold up the centre rear floor hatch slightly
- Remove the hatch by pulling it off the mountings at the front edge
- Remove the storage box underneath and lift it out. If the floor hatch has a carrier bag holder on the underneath, it is secured by a strap on each of the shorter sides of the storage box. These straps must be undone
- Remove the front floor hatch in the same way. (Applies to cars up to and including model year -2004 (CH -133999)).

2B

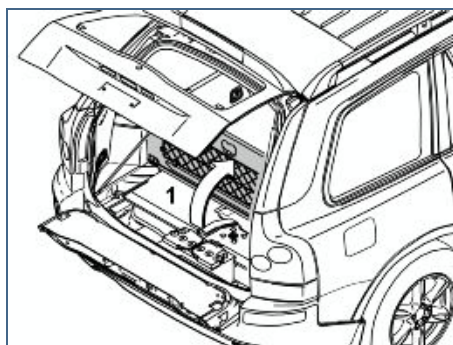

R8903031

Illustration B

Applies to cars with three rows of seats and the integrated carrier bag holder on the underside of the centre floor hatch

- Fold up the centre rear floor hatch (1)
- Release the two straps on the panel underneath. Lift up the panel at the rear edge. Fold back the floor hatch towards the panel. Lift out the floor hatch and panel.

Applies to the XC90 with three rows of seats without integrated carrier bag holders

- Fold up the centre rear floor hatch (1) at the rear edge and lift it out.



3

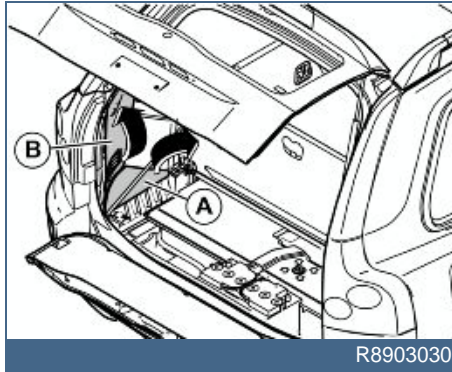

Preparatory work

- Remove the side floor hatch (A) and the folding side panel (B) on the left-hand side in the cargo compartment.

4

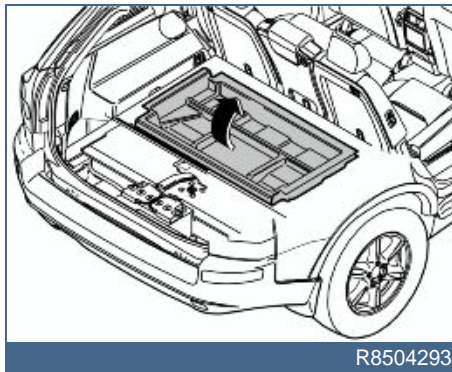

Preparatory work

Applies to cars up to and including model year -2004 (CH -133999)

Applies to cars with two rows of seats

- Remove the front storage compartment.

5

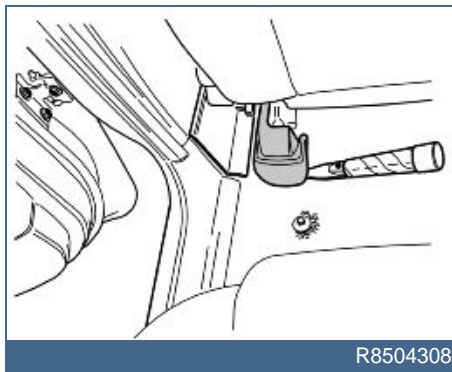

Preparatory work

- Remove the rear panel on the left rear mounting on the left-hand front seat. Pry up the rear edge of the panel slightly and then pull backwards and upwards.

6

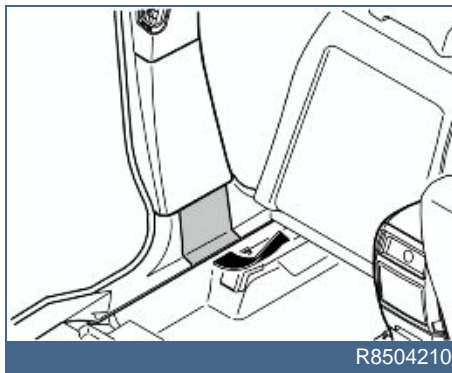

Preparatory work

- Carefully pry off the panel above the joint between the left-hand door sills, at the lower edge. Use a weatherstrip tool.



7

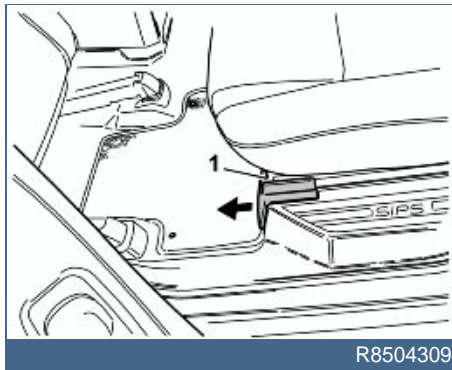

Preparatory work

- Remove the panel for the front mounting on the left-hand seat in the second row of seats by pressing down the catch (1) on top and detaching the panel by pulling it forward
- Remove the screw underneath.

8

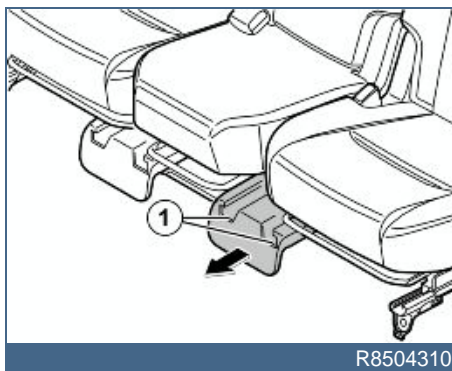

Preparatory work

- Remove the panel for the front mountings on the centre and left-hand seat in the second row. Press down the catches (1) on top and detach the panel by pulling it forward
- Remove the left-hand screw underneath.

9

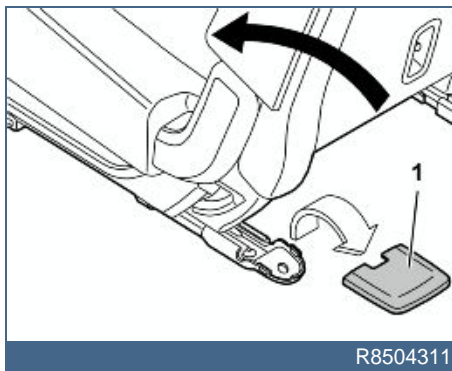

Preparatory work

Applies to cars with two rows of seats

- Fold the backrest on the left-hand seat in the second row of seats forwards.

Applies to cars with three rows of seats

- Fold the left-hand seat backrest forwards in the second row. Slide the backrest forward as far as possible.

Applies to all models

- Remove the covers for the rear mountings for the left-hand seat in the second row. Pry the covers off at the rear edge
- Remove the screws underneath.

10A

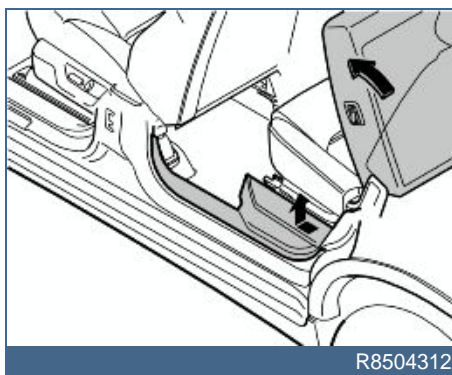

Preparatory work

Illustration A

- Detach the top edge of the sill trim panel to access the seat belt mounting in the end mounting.

Illustration B

- Remove the seat belt from the end mounting. First carefully press down the lug as illustrated in illustration B so that the seat belt releases from the end mounting.



10B

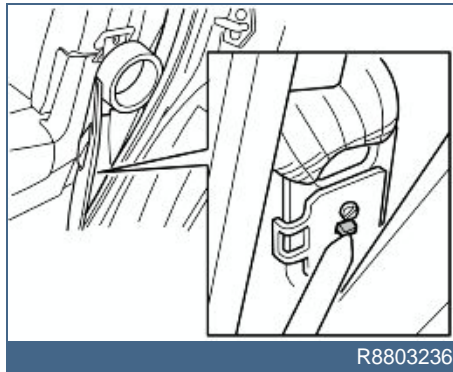

R8803236

Use a weatherstrip tool.

Illustration A

- Continue to pull off the sill trim panel until the remaining clips release
- Unhook the sill trim panel from the B-post panel. Place the sill trim panel in the cargo compartment
- Remove the seat.

Note!

Lift the seat out of the passenger compartment carefully. Ensure that the mountings do not damage the door panels.

11

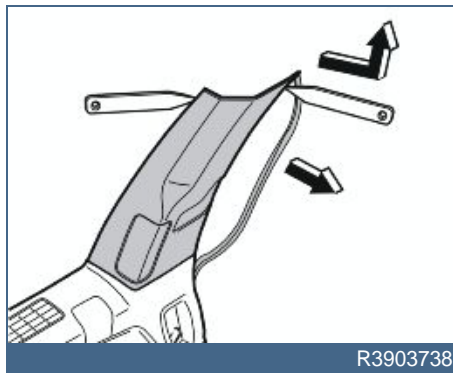

R3903738

Preparatory work Applies to all models

- Pull off the rubber strip at the rear edge of the door opening for the left-hand rear door opposite the left C-post panel
- Carefully pry off the left-hand C-post panel at the sides at the top edge. Use a plastic weatherstrip tool. Pull off until the three clips on the inside release. Do not damage the headlining or the panel
- Remove the panel by pulling upwards slightly and unhooking it from the side panel.

12



R8504307

Preparatory work Applies to cars up to and including model year -2004 (CH -133999)

- Fold up the floor carpet. Secure the floor carpet using one of the seat belts
- Carefully fold up the insulation. Place a shim underneath so that the connector bridge can be exposed.

Note!

Do not damage the insulation. It is brittle and breaks easily.

13

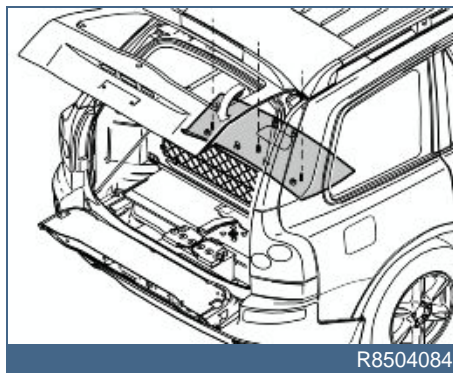

R8504084

Preparatory work Applies to all models

- Remove the covers and the screws underneath for the rear headlining
- Carefully pry off the panel at the rear edge. Use a plastic weatherstrip tool
- Pull the rear edge of the panel downwards until all clips on the inside have released
- Disconnect the connector for the rear roof lighting (applies to cars with three rows of seats)



- Pull the panel backwards to release it.

14

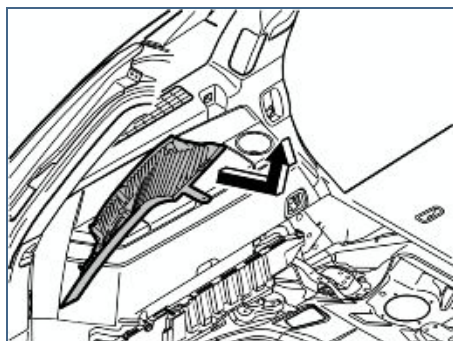

R8504123

Preparatory work

- Pull off the left-hand D-post panel starting at the top edge. Then pull downwards until the three clips on the inside have released. Do not damage the panel
- Remove the panel by pulling upwards slightly and unhooking it from the side panel. Disconnect the connector if the car has a loudspeaker in the D-post.

15A

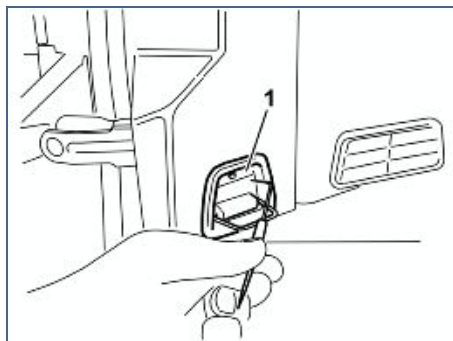

R8504313

Preparatory work

Illustration A shows the removal of the cover for the load securing eyelets for all models

- Fold out the load securing eyelet
- Insert a scribe with an angled tip into the hole in the top of the cover
- Turn the scribe so that the angled tip engages in the reverse of the cover (1). Pull the cover off.

15B

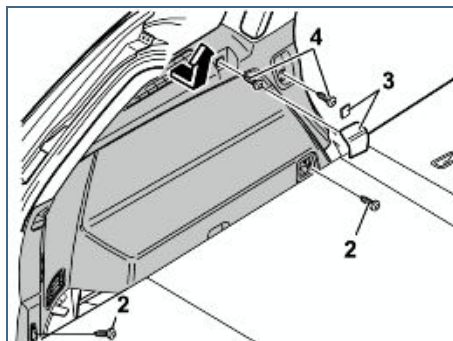

R8504315

Illustration B applies to cars with two rows of seats
Illustration C applies to cars with three rows of seats

- Fold up the seats in the third row (applies to cars with three rows of seats)
- Remove the screws (2) for the load securing eyelets in the left-hand side panel
- Remove the covers (3) over the front mountings for the left-hand side panel. Pry the covers off. Use a plastic weatherstrip tool or a small screwdriver
- Remove the screws (4)

15C

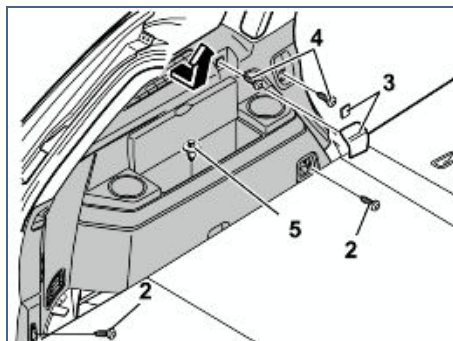

R8504316

- Remove the clip (5) at the bottom of the storage compartment in the panel (Applies to cars with three rows of seats)
- Pull up the panel slightly at the top edge so that the clips on the inside release. Remove the panel by pulling it straight upwards.



16A

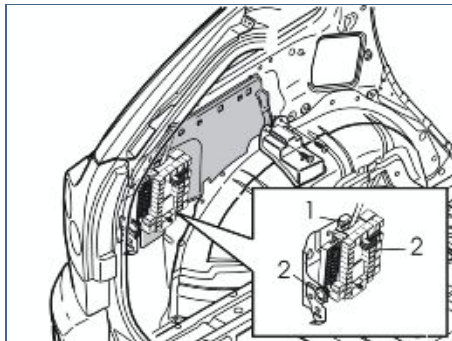

R3904162

Preparatory work

Illustration A

- Remove the rear electronic module (REM). First release the catch (1) on the top of the module
- Fold the module forwards. Lift it out of the mountings (2) and place it to one side.

Illustration B

Applies to cars with three rows of seats

- Remove the panel support at the top edge of the left-hand wheel arch. The panel support is secured using two screws.

16B

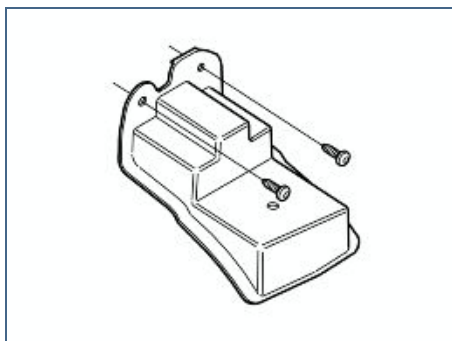

R8504104

17

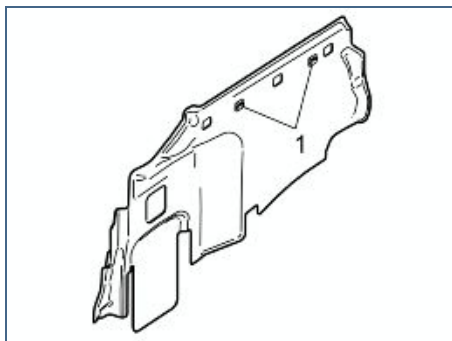

R8504463

Preparatory work

- Remove the insulation panel above and behind the left-hand wheel arch. The insulation panel is secured with two clips (1).

18

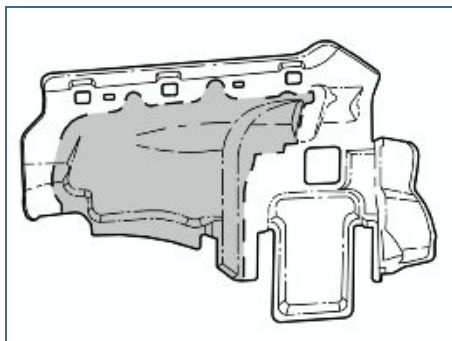

R8504449

Preparatory work

- Go over the embossed dotted line on the reverse of the insulation panel using a marker pen (see the illustration)
- Cut out the insulation panel following the marking. Reinstall the insulation panel.



19

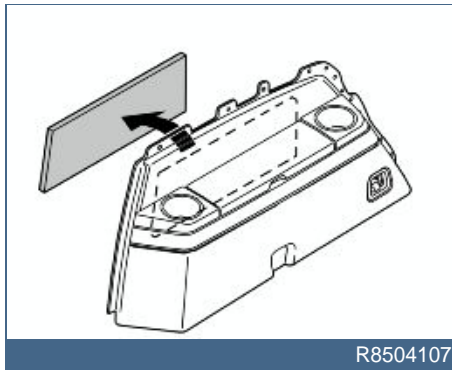

R8504107

Preparatory work

- Take the left side panel and carefully cut away the insulation on its reverse to expose an area in front of the subwoofer.

20

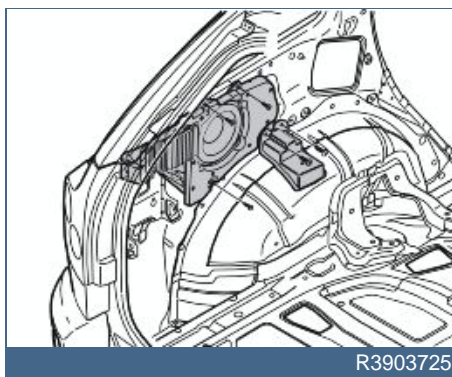

R3903725

Installing the subwoofer

Applies to cars with two rows of seats

- Take the subwoofer, the four screws and the washer from the kit
- Secure the subwoofer using the screws in the existing welded nuts above and behind the left-hand rear wheel arch. The washer must be positioned at the front/lower mounting of the subwoofer.

Applies to cars with three rows of seats

- Take the subwoofer and the four screws from the kit
- Secure the subwoofer using the two upper and the lower rear screws in the existing welded nuts. (The front/lower screw is the same as the rear screw for the panel support.)
- Reinstall and tighten the panel support. (The washer is not required).

Applies to all models

- Tighten the M6 screws. Tighten to **10 Nm (7 lbf.ft.)**. Tighten the M8 screw. Tighten to **24 Nm (18 lbf.ft.)**.

21

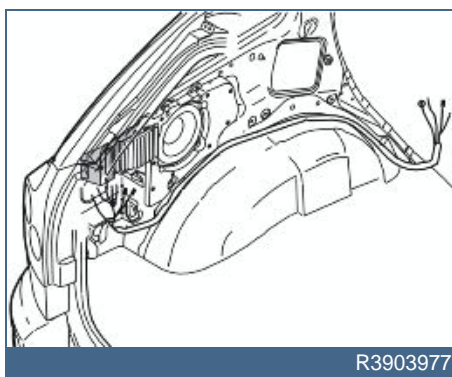

R3903977

Cable routing and connecting to the fusebox and Subwoofer

Applies to cars up to and including model year -2004 (CH -133999)

- Take the cable harness (A in the kit illustration) from the kit. Position the end of the cable harness, with two plastic connectors, at the rear of the fuse holder
- Route the cable harness along the upper edge of the left-hand rear wheel well. Continue along the front edge of the wheel arch, under the member for the rear mounting for the second row of seats and up to connector bridge under the left-hand seat on the second row of seats.



22

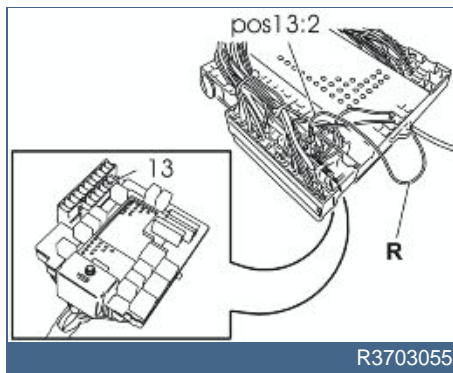

R3703055

Cable routing and connecting to the fusebox and Subwoofer

- Take the red cable from the cable harness. Install the cable on the reverse of the fusebox in position 13 and socket 2 as illustrated
- Take the 15 Amp fuse from the kit. Install the fuse in position 13 in the fusebox.

23

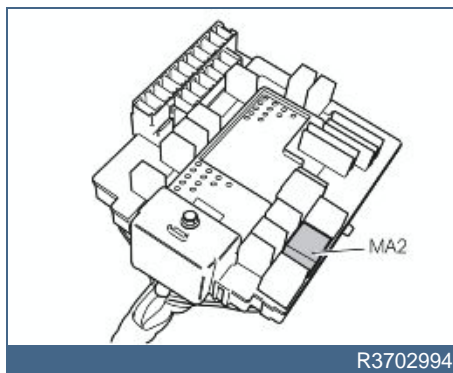

R3702994

Cable routing and connecting to the fusebox and Subwoofer

- Take the relay from the kit. Install the relay in position MA2 in the fusebox.

24

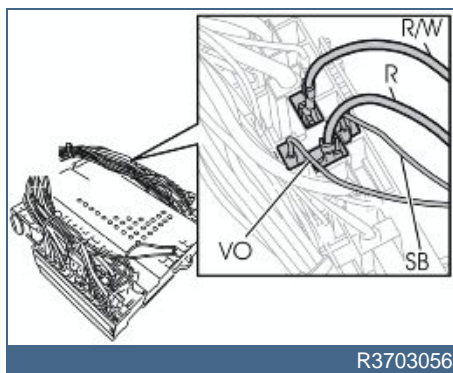

R3703056

Cable routing and connecting to the fusebox and Subwoofer

- Connect the four contiguous cables on the reverse of the fusebox to relay position MA2 as follows:

Red/white (R/W) cable to terminal 1

Black (SB) cable to terminal 2

Red (R) cable to terminal 3

Violet (V) cable to terminal 4.

25

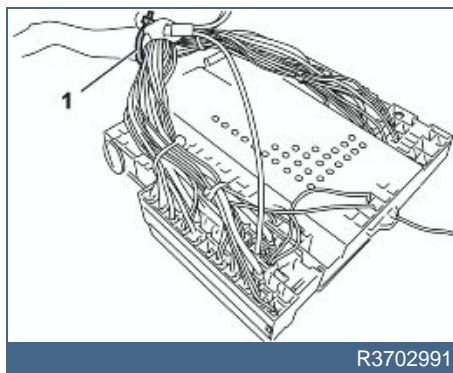

R3702991

Cable routing and connecting to the fusebox and Subwoofer

- Clamp the cables connected to the reverse of the fusebox at the cable harness for the fusebox. Use a tie strap (1) from the kit.



26

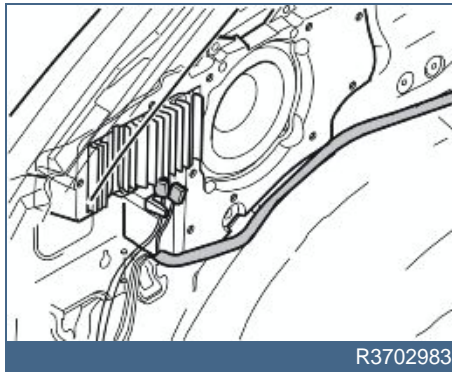

Cable routing and connecting to the fusebox and Subwoofer

- Connect the two connectors on the cable harness to the two sockets underneath the amplifier section of the subwoofer.

27

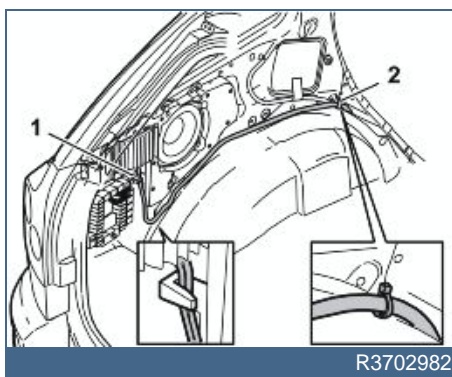

Cable routing and connecting to the fusebox and Subwoofer

- Press the cable harnesses into place on the subwoofer into the existing clamp (1)
- Reinstall the fusebox
- Now adjust the routing of the cable harnesses up to the front edge of the wheel arch so that it reaches the subwoofer. Carefully press the cable harness under the lower edge of the subwoofer so that it remains in place. Clamp the cable harness at point (2) using a cable harness from the kit.

Applies to cars with three rows of seats

- Ensure that the cable harness is positioned as far to the left as possible on the panel support for the left-hand side panel. This is to prevent the cable harness from being trapped
- Tape the cable harness at the panel support.

28

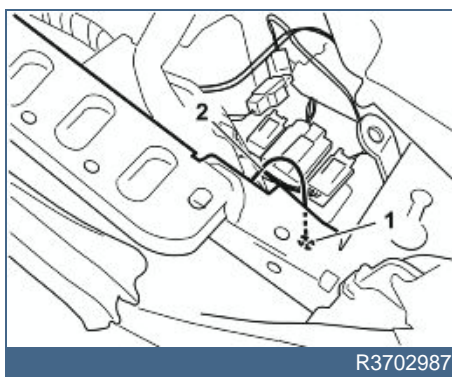

- Slacken off the screw for the existing ground lead under the panel (1). Pull up and connect the routed ground lead (2) together with the existing ground lead. Tighten the screw.



29

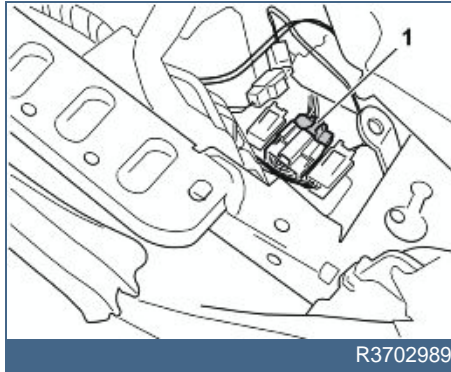

R3702989

- Press down the catch on top of the largest connector (1) (14-pin). Pull it off the connector in the connector bridge.

30

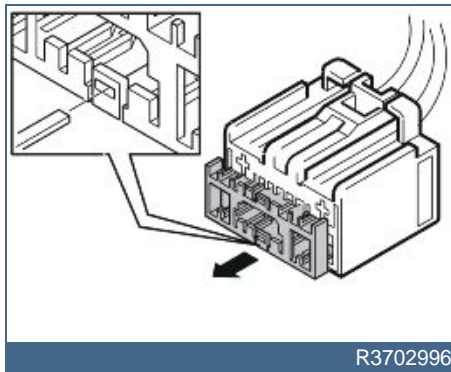

R3702996

- Depress the catch on the red secondary lock on the connector. Pull the connector out to its limit position.

31

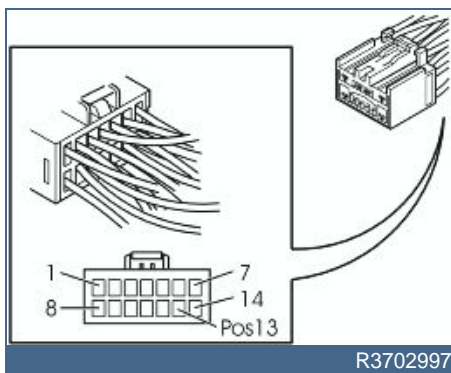

R3702997

- Take the violet cable and install it in terminal 13 on the reverse of the connector as illustrated
- Press the secondary lock into place on the connector. Reinstall the connector.

32

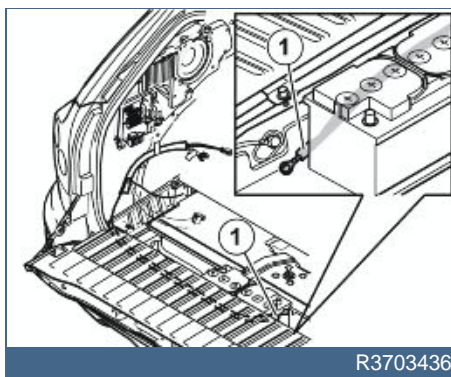

R3703436

Applies to cars from model year 2005- (CH 134000-)

- Take the cable harness B (see the kit illustration) and position as illustrated
- Route the ground lead (1) through the socket at the rear edge of the left-hand floor support. Continue to route the cable behind the battery and up to the ground terminal at the rear crossmember on the right-hand side of the battery
- Remove the existing ground terminal. Install the routed ground lead
- Tighten the ground terminal securely.



33

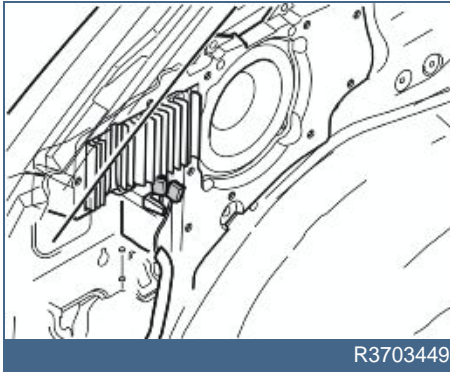

- Connect the two bound connectors on the cable harness to the two sockets underneath the amplifier section of the subwoofer.

34

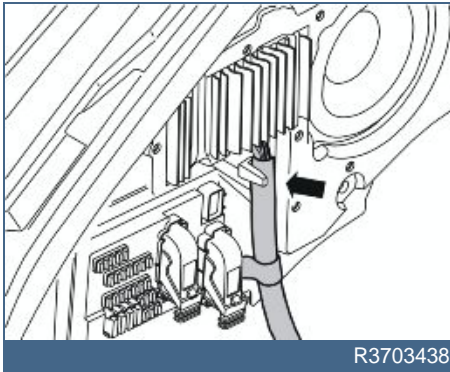

- Press the cable harness connected to the subwoofer into the existing clamp.

35

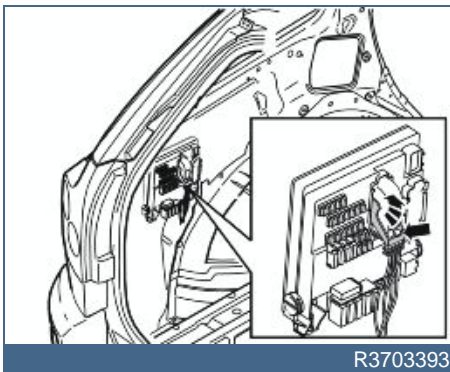

- Press in the catches on the rear brown connector in the fuse holder in the cargo compartment. Turn up the lock arm as far as possible. Pull out the connector.

36

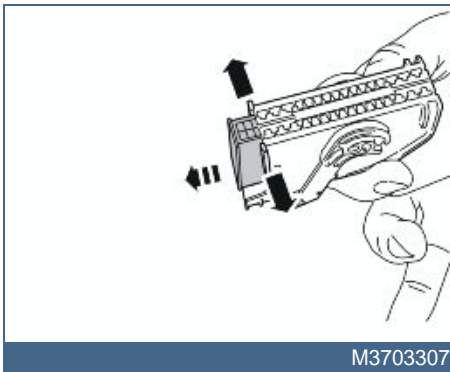

- Carefully pull apart the sides of the holder for the connector at the ends so that the connector can pass by the catches
- Pull the connector out.



37

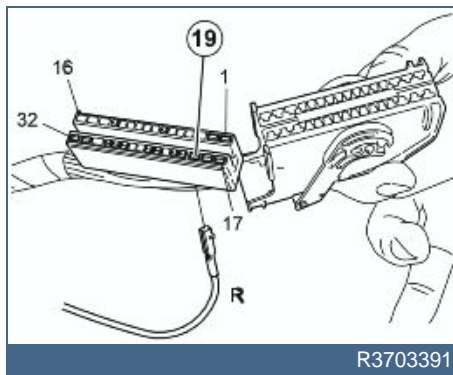

R3703391

Note!

Make a note of the position number of the connector. The position numbers are located on the ends of the connector and in the bottom of the fuse holder.

- Connect the new red (R) cable to terminal 19 in the connector. If the car is prepared for rear air conditioning (A/C) there is already a cable installed in this terminal. Disconnect the cable. Insulate the cable. Secure the cable. Press in the new red (R) cable instead
- Press the connector into its holder. Reinstall the connector to the fuse holder.

38

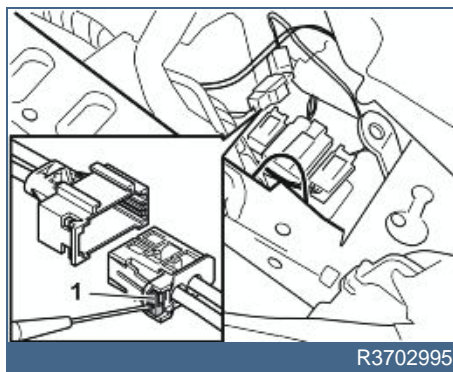

R3702995

Applies to cars up to and including model year -2004 (CH -133999)

- Carefully pull the cable splice for the existing orange fibre optic cables to the side of the connector bridge
- Disconnect the connectors from each other. First depress the catch (1) and then separate them.

39

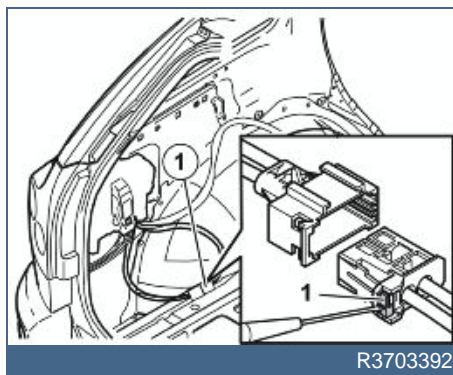

R3703392

Applies to cars from model year 2005- (CH 134000-)

- Carefully pull the pipe coupling to the existing orange fibre optic cables, under the rear fuse holder
- Disconnect the connectors from each other. First depress the catch (1) and then separate them.

40

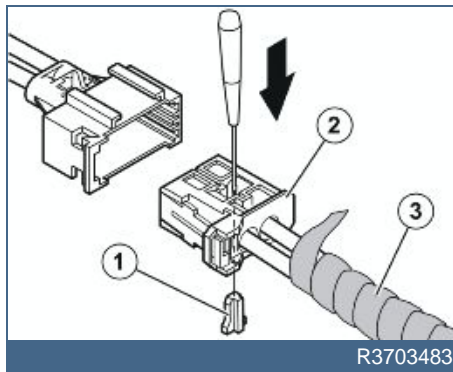

R3703483

Applies to all models

- Detach approximately 10 cm of tape so that the wiring can move freely. Cut off the detached piece of tape
- Carefully press out the blue catch (1) in the connector (2). Do not damage the catch. It is small and falls out easily.



41

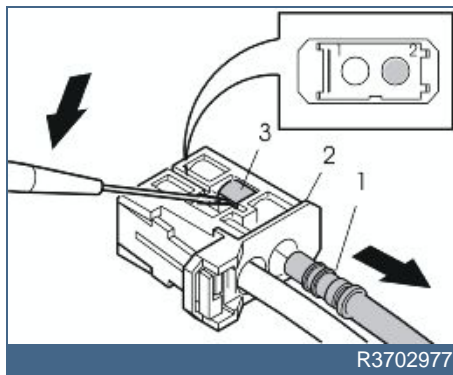

R3702977

- Remove the fibre cable (1) from the connector (2). First carefully pry up the locking tab (3) and at the same time pull off the fibre optic cable.

Note!

Do not open the locking tab more than is necessary as it is fragile and easy to break.

42

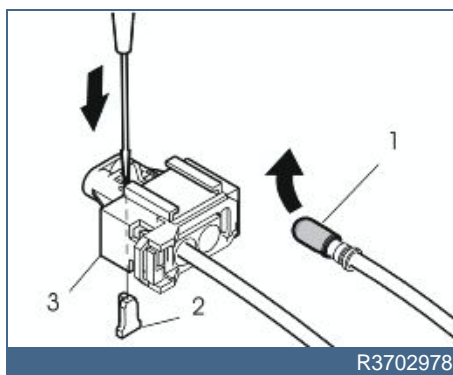

R3702978

- Take the pre-routed cable harness
- Carefully press out the blue catch (2) in the connector (3). Do not damage the catch
- Remove the protective cap (1) from the loose fibre optic cable in the cable harness.

43

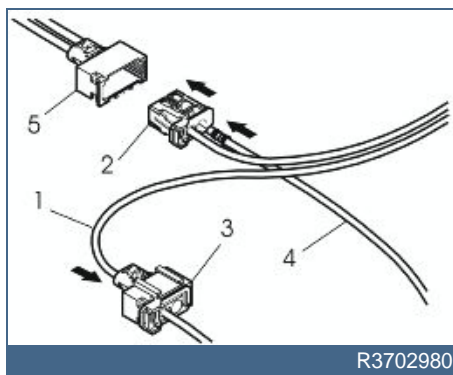

R3702980

- Press in the fibre optic cable (1) (previously disconnected from the existing connector in the car) into the connector (3) until there is an audible click.

Note!

The fibre optic cables must be positioned opposite each other so that they meet in the connector.

- Reinstall the blue catch
- Press the fibre optic cable (4) (from the routed cable harness) into place in the same position in the connector (2) where the existing fibre optic cable was disconnected previously. There must be an audible click
- Reinstall the blue catch
- Connect connectors 2 and 5 to each other.



44

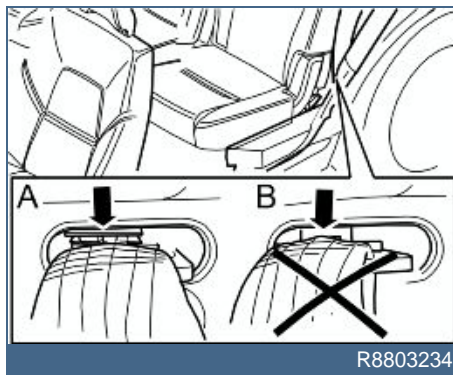

Finishing work

- Reinstall the fibre optic cables and secure the two loose connectors at the existing cable harness. Use tape or tie straps from the kit.

Note!

Ensure that the fibre optic cables do not have a radius of more than 30 mm (1 3/16") and are not positioned so that there is a risk of being trapped or rubbed.

- Remove the shim under the polystyrene insulation and then reinstall. (Applies to cars up to and including model year -2004 (CH -133999))
- Fold back the carpet. (Applies to cars up to and including model year -2004 (CH -133999))
- Reinstall the side panel and cover using screws. Tighten the screws for the load securing eyelets. Tighten to **24 Nm (18 lbf.ft)**
- Reinstall the D-post panel and connect the connector for the D-post loudspeaker (if applicable)
- Connect the connector for the lighting in the rear headlining (applies to cars with three rows of seats)
- Reinstall the rear headlining
- Reinstall the C-post panel. (Applies to cars up to and including model year -2004 (CH -133999))
- Reinstall the seat. Tighten the screws. Tighten to **48 Nm (35 lbf.ft)**. (Applies to cars up to and including model year -2004 (CH -133999))
- Reinstall the panel over the door sill and the panels over the seat mountings as well as the panel at the bottom edge of the B-post panel. (Applies to cars up to and including model year -2004 (CH -133999))

Note!

- See the illustration!

Press the seat belt into the end mounting.

Note!

A click should be heard when the seat belt is locked correctly into the end mounting.

Note!

Check that the seat belt engages correctly in the end mounting by looking at the reverse of the mounting. The position of the lock facing against the end mounting, with the seat belt fully inserted, must be: A= Correct position. B= If the lock facing does not lock correctly against the end mounting (see A), replace the end mounting for a new one.

**Note!**

Check that the seat belt is securely positioned by jerking the belt upwards.

(Applies to cars up to and including model year -2004 (CH -133999))

- Re-position the seats
- Reinstall the folding panel.

45

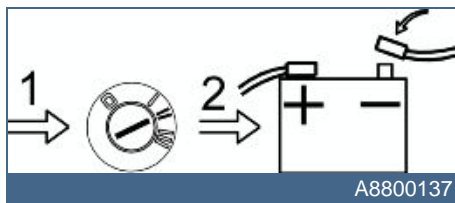
**Finishing work**

- Turn the ignition key to position II
- Reconnect the battery negative lead
- Reinstall the left-hand side floor hatch and the storage boxes
- Reposition the floor hatches
- Program the software according to the service information in VIDA.