



Bay Window Rear/Top Convertible Direct Vent Fireplaces Model: DVRTSB

INSTALLER/CONSUMER SAFETY INFORMATION

PLEASE READ THIS MANUAL
BEFORE INSTALLING AND USING
APPLIANCE

WARNING!
IF THE INFORMATION IN THIS
MANUAL IS NOT FOLLOWED
EXACTLY, A FIRE OR EXPLOSION
MAY RESULT, CAUSING
PROPERTY DAMAGE, PERSONAL
INJURY OR LOSS OF LIFE.

FOR YOUR SAFETY

Installation and service must be
performed by a qualified installer,
service agency or your gas supplier.

WHAT TO DO IF YOU SMELL GAS:

- Do not try to light any appliance.
- Do not touch any electric switch; do not use any phone in your building.
- Immediately call your gas supplier from your neighbor's phone. Follow the gas suppliers instructions.
- If you cannot reach your gas supplier call the fire department.

DO NOT STORE OR USE GASOLINE OR
OTHER FLAMMABLE VAPORS AND/OR
LIQUIDS IN THE VICINITY OF THIS OR
ANY OTHER APPLIANCE.

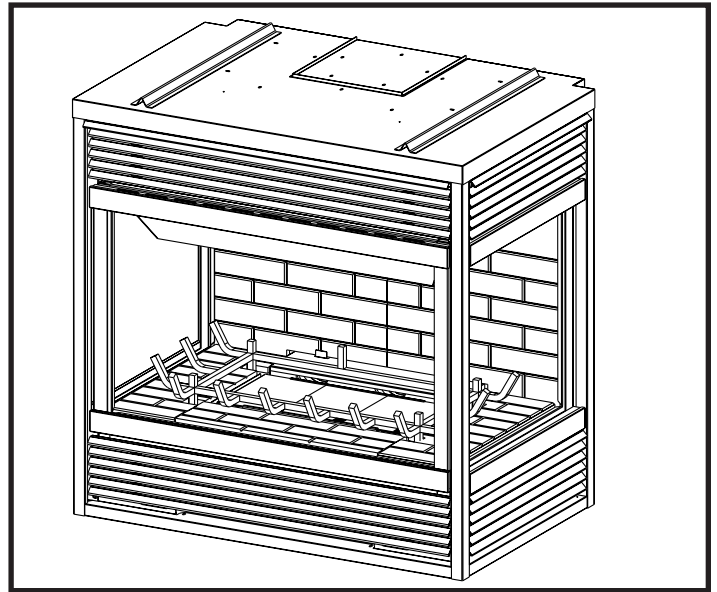

Homeowner's Installation and Operating Manual



INSTALLER: Leave this manual with the appliance.
CONSUMER: Retain this manual for future reference.

Table of Contents

Thank you & congratulations on your purchase of a CFM Corporation fireplace.

PLEASE READ THE INSTALLATION & OPERATING INSTRUCTIONS BEFORE USING APPLIANCE.

IMPORTANT: Read all instructions and warnings carefully before starting installation. Failure to follow these instructions may result in a possible fire hazard and will void the warranty.

Installation & Operating Instructions	
Important Curing/Burning Instructions	3
Fireplace Dimensions	4
Locating Your Fireplace	6
Clearance to Combustibles	6
Mantels	6
Hearths	6
Framing & Finishing	6
Final Finishing	7
Gas Specifications	7
Gas Inlet and Manifold Pressures	7
High Elevations	7
Gas Line Installation	7
EB-1 Electrical Box Connection	8
Remote ON/OFF Switch Installation	8
Alternate Switch Location	8
Optional Top Vent Application	9
Venting Installation Instructions	
General Venting Information-Termination Location	10
General Information For Connecting Vent Pipes	12
How to Use the Vent Graph	13
Rear Wall Vent Applications & Installation	13
Vertical Sidewall Applications & Installation	14
Below Grade Installation	17
Vertical Through-the-Roof Applications & Installation	18
Vertical Through the Roof Installation	18
Twist Lock Vent Components	20
Operating Instructions	
Glass Information	21
Louvre Removal	21
Glass/Frame Removal	21
Glass Cleaning	22
Ceramic Refractory Installation	22
Installation of Logs	22
Lava Rocks & Ember Material	23
Flame & Temperature Adjustment	23
Flame Characteristics	23
Lighting & Operating Instructions	24
Trouble Shooting Guide	25
Fuel Conversion Instructions	27
Maintenance	28
Replacement Parts	29
Optional Accessories	
Fan Kits	32
Remote Controls	33
Warranty	35

Installation & Operating Instructions

This gas appliance should be installed by a qualified installer in accordance with local building codes and with current **CSA-B149.1** Installation codes for Gas Burning Appliances and Equipment. For U.S.A Installations follow local codes and/or the current **National Fuel Gas Code ANSI Z223.1/NFPA 54**.

In the Commonwealth of Massachusetts, all gas fitting and installation of this heater shall only be done by a licensed gas fitter or licensed plumber.

FOR SAFE INSTALLATION AND OPERATION PLEASE NOTE THE FOLLOWING:

1. This fireplace gives off high temperatures and should be located out of high traffic areas and away from furniture and draperies.
2. Children and adults should be alerted to the hazards of high surface temperatures of this fireplace and should stay away to avoid burns or ignition of clothing.
3. **CAUTION: Due to high glass surface temperature children should be carefully supervised when in the same room as fireplace.**
4. Under no circumstances should this fireplace be modified. Parts removed for servicing should be replaced prior to operating this fireplace again.
5. Installation and any repairs to this fireplace must be performed by a qualified installer, service agency or gas supplier. A professional service person should be contacted to inspect this fireplace annually. Make it a practice to have all of your gas fireplaces checked annually. More frequent cleaning may be required due to excess lint and dust from carpeting, bedding material, etc.
6. Control compartments, burners and air passages in this fireplace should be kept clean and free of dust and lint. Make sure the gas valve and pilot light are turned off before you attempt to clean this fireplace.
7. The venting system (chimney) of this fireplace should be checked at least once a year and if needed your venting system should be cleaned.
8. Keep the area around your fireplace clear of combustible materials, gasoline and other flammable vapor and liquids. This fireplace should not be used as a drying rack for clothing, nor should Christmas stockings or decorations be hung in the area of it.
9. Under no circumstances should any solid fuels (wood, coal, paper or cardboard etc.) be used in this fireplace.
10. The flow of combustion and ventilation air must not be obstructed in any way.

11. When fireplace is installed directly on carpeting, vinyl tile or any combustible material other than wood, this fireplace must be installed on a metal or wood panel extending the full width and depth of the fireplace.
12. This fireplace requires adequate ventilation and combustion air to operate properly.
13. This fireplace must not be connected to a chimney flue serving a separate solid fuel burning fireplace.
14. When the fireplace is not in use it is recommended that the gas valve be left in the OFF position.

WARNING: Check with your electronics manufacturer before installing a television or other electronic device above this fireplace.

Proposition 65 Warning: Fuels used in gas, wood-burning or oil fired appliances, and the products of combustion of such fuels, contain chemicals known to the State of California to cause cancer, birth defects and other reproductive harm.
California Health & Safety Code Sec. 25249.6

This appliance may be installed in an aftermarket permanently located, manufactured home or mobile home, where not prohibited by local codes.
This appliance is only for use with the type of gas indicated on the rating plate. This appliance is not convertible for use with other gases, unless a certified kit is used.
The DVRTSB has been approved for mobile home installations.

IMPORTANT:

PLEASE READ THE FOLLOWING CAREFULLY

Remove any plastic from trim parts before turning the fireplace ON.
It is normal for fireplaces fabricated of steel to give off some expansion and/or contraction noises during the start up or cool down cycle. Similar noises are found with your furnace heat exchanger or car engine. It is not unusual for a gas fireplace to give off some odor the first time it is burned. This is due to the curing of the paint and any undetected oil from the manufacturing process.

Please ensure that your room is well ventilated - open all windows during burn in period.

It is recommended that you burn your fireplace for at least ten (10) hours the first time you use it. If the optional fan kit has been installed, place the fan switch in the "OFF" position during this time.

Fireplace Dimensions (Installed as Top Vent)

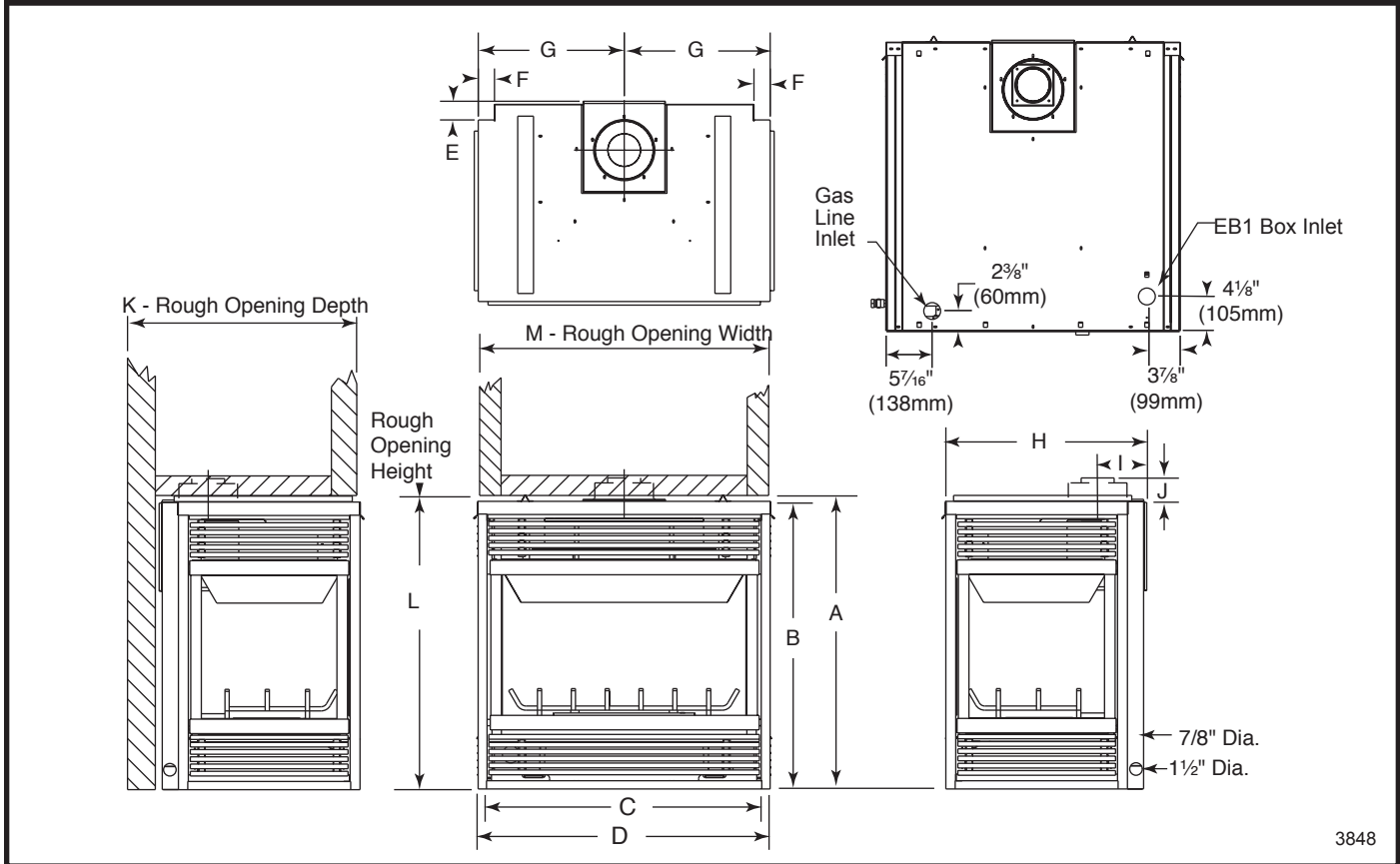

3848

Fig. 2 Fireplace specifications and framing dimensions.

Ref.	DVRTSB (Top Vent)
A	35" (888 mm)
B	34 3/8" (873 mm)
C	32 3/4" (831 mm)
D	34 7/8" (885 mm)
E	2 1/4" (56 mm)
F	2" (51 mm)
G	17 1/2" (444 mm)
H	24" (610 mm)
I	5 1/2" (139 mm)
J	2 3/8" (61 mm)
Framing Dimensions	
K	24" (610 mm) minus one finishing material thickness to be even with face of unit
L	Not to be framed until unit is set in place due to 3 1/8" (79 mm) allowance for flue collar.
M	35" (888 mm) minus twice the finishing material thickness to be even with face of unit.

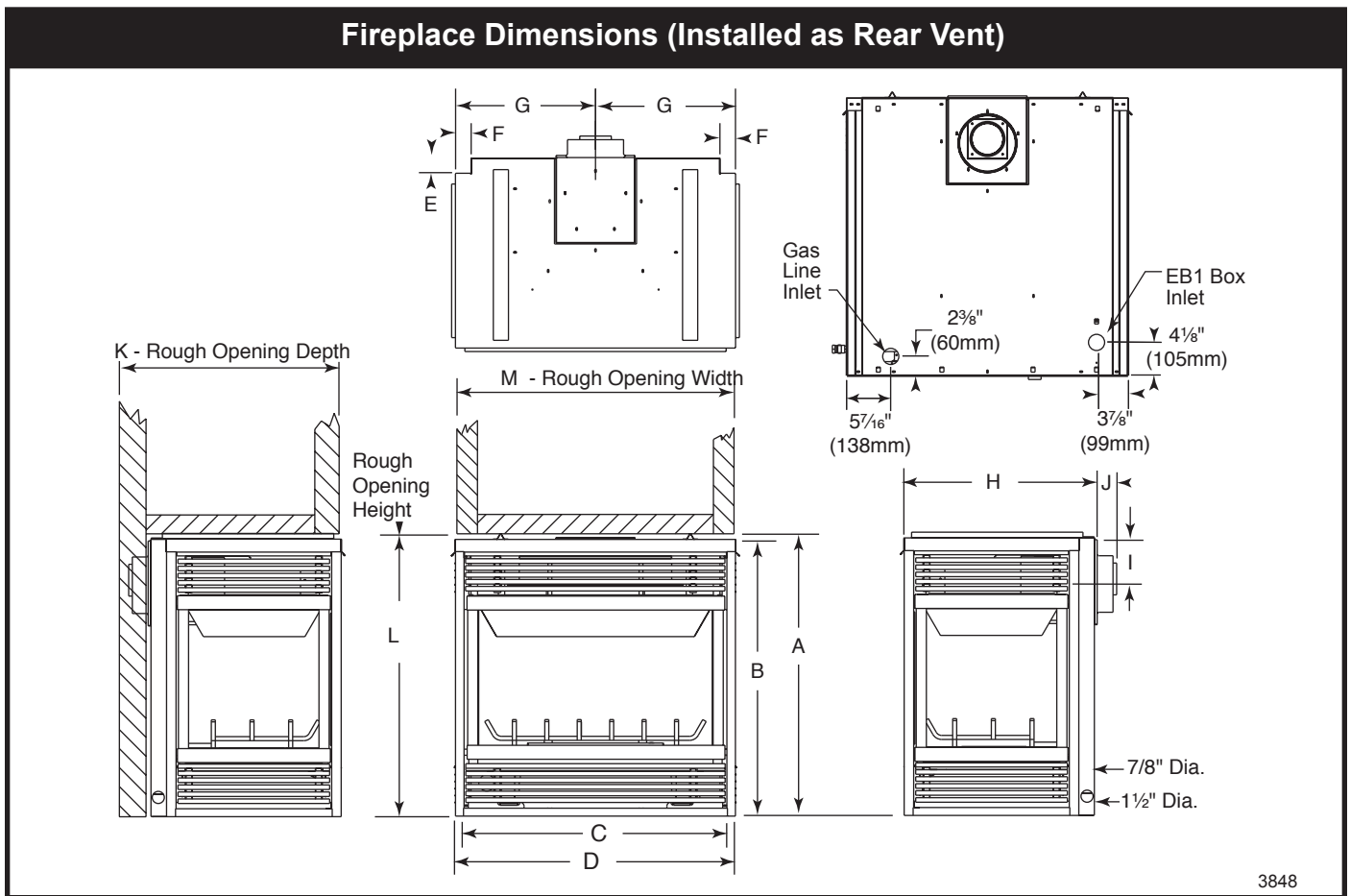

Fig. 3 Fireplace specifications and framing dimensions.

Ref.	DVRTSB (Rear Vent)
A	35" (888 mm)
B	34 3/8" (873 mm)
C	32 3/4" (831 mm)
D	34 7/8" (885 mm)
E	2 1/4" (56 mm)
F	2" (51 mm)
G	17 1/2" (444 mm)
H	24" (610 mm)
I	5 3/4" (139 mm)
J	2 3/8" (61 mm)
Framing Dimensions	
K	24" (609 mm) minus one finishing material thickness to be even with face of unit
L	35 1/4" (895 mm)
M	35" (888 mm) minus twice the finishing material thickness to be even with face of unit.

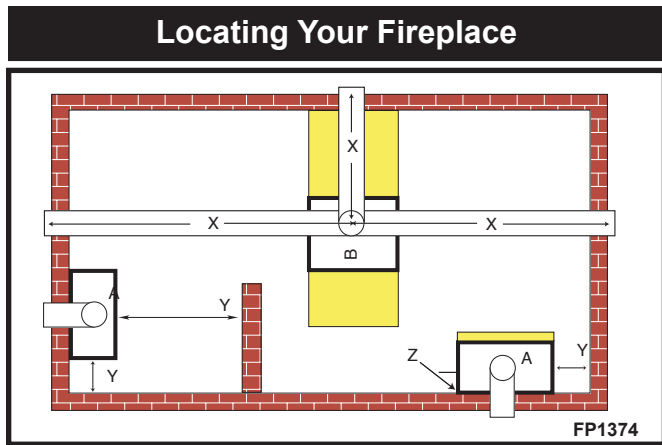

Fig. 1 Locating gas fireplace.

- A. Wall Location (Fig. 1)
 - Y (Minimum distance between a glass panel and a parallel wall = 3' (914 mm))
 - Z (Minimum distance between edge of a glass panel and an adjacent wall = 2-3/4" (70 mm))
- B. Island Location (Fig. 1)
 - X (Maximum length of horizontal venting = 20' (6.1 m). Refer to the venting section of this manual for specific dimensions.)

Clearance to Combustibles

- Top of Unit to Ceiling 36" (914 mm)
- Front of Unit to Combustibles 36" (914 mm)

Appliance

- Top (0") 0 mm to stand-off
- Bottom (0") 0 mm
- Back (1/2") 13 mm to rear panel
- Side Wall (0") 0 mm. (behind side glass panel)

Venting

- Concentric sections of DV Vent
 - Top, bottom & sides (1") 25 mm
- Non-concentric sections of DV Vent
 - Side and bottom (1") 25 mm
 - Top (2") 51 mm

Mantels

The height that a combustible mantel is fitted above the fireplace is dependent on the depth of the mantel. This also applies to the distance between the mantel leg (if fitted) and the fireplace.

For the correct mounting height and widths refer to Figure and the Mantel Chart below.

Noncombustible mantels and legs may be installed at any height and width around the appliance.

 **When using paint or lacquer to finish the mantel, such paint or lacquer must be heat resistant to prevent discoloration.**

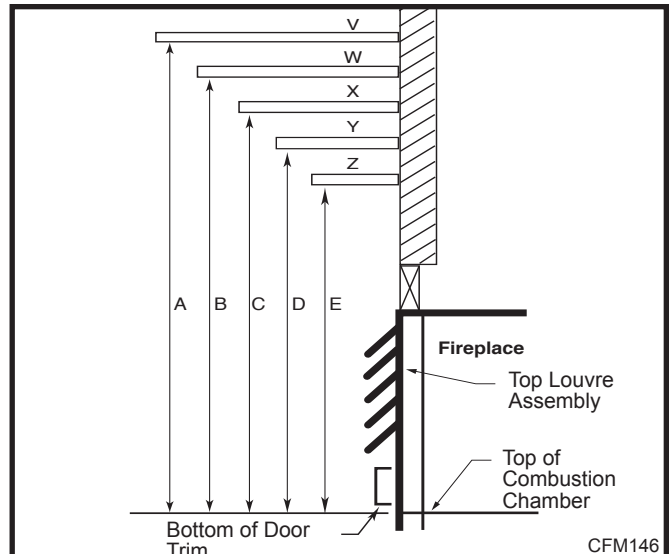

Mantel Chart

Ref.	Mantel Shelf or Breast Plate Depth	Ref.	Mantel from Top of Comb. Chamber
V	10" (254 mm)	A	19" (483 mm)
W	8" (203 mm)	B	17" (432 mm)
X	6" (152 mm)	C	15" (381 mm)
Y	4" (101 mm)	D	13" (330 mm)
Z	2" (51 mm)	E	11" (279 mm)

Fig. 4 Combustible mantel minimum installation.

NOTE: The above mantel shelf chart will be applied for the front and two sides of the fireplace.

Hearth

A hearth is not mandatory but is recommended for aesthetic purposes. We recommend a noncombustible hearth which projects out 12" (305mm) or more from the front of the fireplace.

Cold climate installation recommendation:

 **When installing this unit against a non-insulated exterior wall or chase, it is mandatory that the outer walls be insulated to conform to applicable insulation codes.**

Framing and Finishing

1. Choose the unit location.
2. Place the unit into position and secure it to the floor with 1½" (38 mm) screws, or nails. The holes to secure the unit to the floor are located just behind the access door grille on the left and right side of the unit.
3. Frame in the fireplace with a header across the top. It is important to allow for the finished wall face when setting the depth of the frame.
4. Drywall (sheetrock) or wood material may be placed with a zero clearance to the top edges of the appli-

ance when finishing walls above sides of the appliance with glass windows. Attach the wall finishing to the constructed frame **not the appliance**.

- On DVRTSB models, drywall, wood or wood molding may be placed with zero clearance to the rear wall of the unit, along the vertical edge formed by the standoffs to intersection of the rear wall to the side wall containing the small glass window. Attach the wall finishing to the constructed frame, **not the appliance**.

Final Finishing

Noncombustible materials such as brick or tile may be extended over the edges of the face of the appliance. **DO NOT** cover any vent or grille panels.

If a Trim Kit is going to be installed on the fireplace, the brick or tile will have to be installed flush with the edges of the appliance.

Gas Specifications

Model	Fuel	Gas Control	Max. Input BTU/h	Min. Input BTU/h
DVRTSB RN	Nat	Millivolt	30,000	21,000
DVRTSB RP	Prop	Millivolt	30,000	22,500

Gas Inlet and Manifold Pressures

	Natural	LP (Propane)
Inlet Minimum Pressure	5.5" w.c.	11.0" w.c.
Inlet Maximum Pressure	14.0" w.c.	14.0" w.c.
Manifold Pressure	3.5" w.c.	10.0" w.c.

High Elevations

Input ratings are shown in BTU per hour and are certified without deration for elevations up to 4,500 feet (1,370m) above sea level.

For elevations above 4,500 feet (1,370m) in USA, installations must be in accordance with the current ANSI Z223.1/NFPA 54 and/or local codes having jurisdiction.

In Canada, please consult provincial and/or local authorities having jurisdiction for installations at elevations above 4,500 feet (1,370m).

DVRTSB Certified To

ANSI Z21.88 - 2005 / CSA 2.33 - 2005
Vented Gas Fireplace Heaters

Units: B02A01, B02B01

Gas Line Installation



When purging the gas lines, the front glass must be removed.

The gas pipeline can be brought in through the side and back of the fireplace as well as the bottom. Knockouts are provided on the bottom behind the valve to allow for the gas pipe installation and testing of any gas connection. It is most convenient to bring the gas line in from the right side of the valve as this allows fan installation or removal without disconnecting the gas line.

The gas line connection can be made with properly tinned 3/8" copper tubing, 3/8" rigid pipe or an approved flex connector. Since some municipalities have additional local codes, it is always best to consult your local authority and the **CSA-B149.1** installation codes.

For USA installations consult the current National Fuel Gas Code, **ANSI Z223.1/NFPA 54**.



Always check for gas leaks with a mild soap and water solution. Do not use an open flame for leak testing.

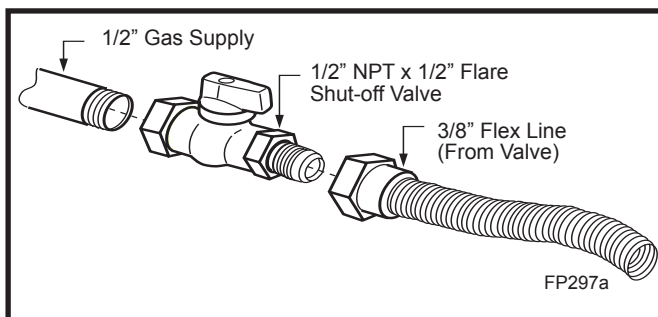

Fig. 5 Typical gas supply installation.

The gas control is equipped with a captured screw type pressure test point, therefore it is not necessary to provide a 1/8" test point up stream of the control.

When using copper or flex connector use only approved fittings. Always provide a union when using black iron pipe so the gas line can be easily disconnected for burner or fan servicing. Refer to the gas specification for pressure details and ratings.



The fireplace valve must not be subjected to any test pressures exceeding 1/2 psi. Isolate or disconnect this or any other gas appliance control from the gas line when pressure testing.

EB-1 Electrical Box



The fireplace, when installed, must be electrically connected and grounded in accordance with local codes or, in the absence of local codes, with the current CSA C22.1 Canadian Electrical Code



For USA installations follow the local codes and the national electrical code ANSI/NFPA No. 70.



It is strongly suggested that the wiring of the EB-1 Electrical Junction Box be carried out by a licensed electrician.



Ensure that the power to the supply line has been disconnected before commencing this procedure.

The EB-1 Electrical junction box has been supplied standard on this model to allow for the easy connection of an optional fan kit. (Fig.)

To connect the EB-1 box to the house electrical supply follow the steps below.

1. Remove the front cover of the EB-1 box.
2. Remove the plug socket assembly from the EB-1 box.
3. Feed the supply line in from the outside through the electrical knock-out.
4. Connect the ground wire of the supply line to the green screw of the socket assembly.
5. Connect the white wire of the power line to the chrome screw of the socket assembly.
6. Connect the black wire of the power supply line to the brass screw (polarized) of the socket assembly.
7. Refit the socket assembly back into the electrical box and replace the cover plate.
8. The EB-1 electrical junction box is now ready to supply power to the FK12 or FK24 fan kits, if fitted.

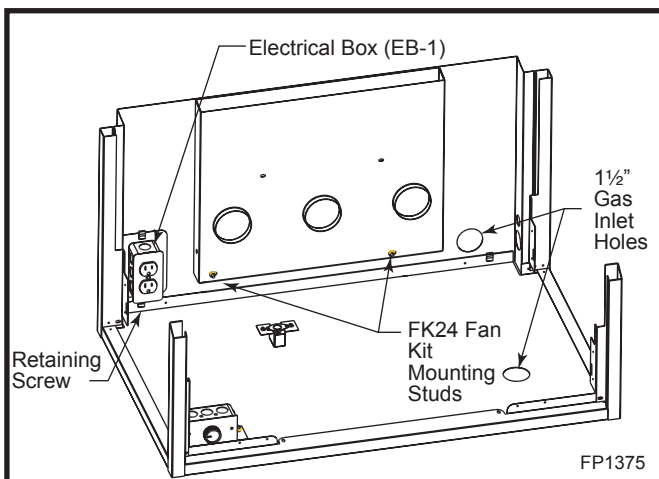

Fig. 6 EB-1 electrical box.

Remote ON/OFF Switch Installation

1. Thread the wiring through the holes on the end panels of the appliance. Take care not to cut the wire or insulation on metal edges. Route the wire to a conveniently located receptacle box.
2. Attach the wire to the ON/OFF switch and install the switch into the receptacle box.
3. Connect the other ends of the wire to the gas control valve. (Fig. 7)

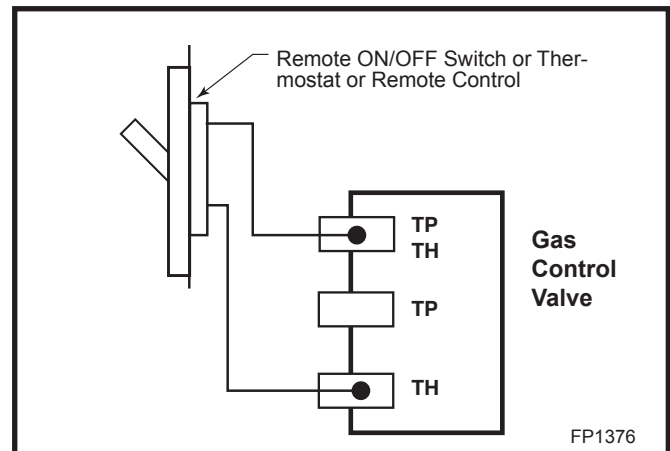

Fig. 7 Remote switch wiring diagram.

Alternate Switch Location

The remote switch can be installed on the front/side of the access door. Simply mount the switch to the bracket provided and screw the bracket to either side of the frame, lining up the screws with the pre-punched holes. (Fig. 8)

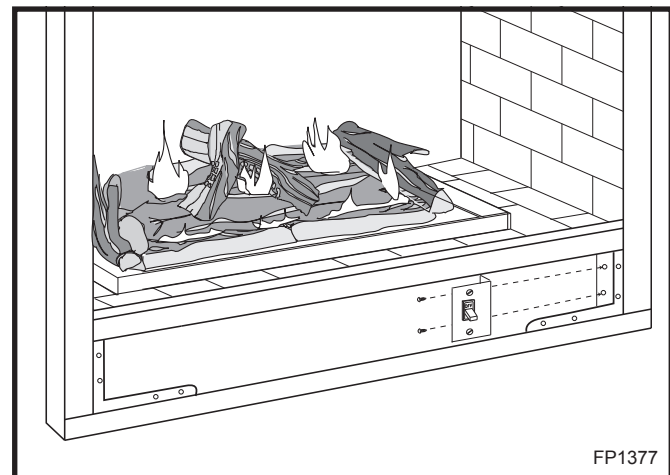

Fig. 8 Alternate switch location.

Optional Top Vent Application

This appliance is shipped as a rear vent unit. If the installation layout requires the unit to be a top vent configuration the appliance can be converted by following the steps below.

When removing and refitting the plates and adapter be sure the associated gaskets are undamaged and refitted as required.

1. Remove the 10 screws securing the outer collar adapter to the fireplace body. (Fig. 9)
2. Set the collar aside, complete with the gasket. Do not damage the gasket as the adapter and gasket must be refitted.
3. Remove all of the insulation material (exposed in Step 2) from the top of the unit. (Fig. 10) This material can be discarded, however if the unit is converted back to rear vent for any reason a new piece of insulation material approved by CFM Corporation must be used for this purpose.
4. Remove the four (4) screws securing the flue cover plate to the top of the intake box and remove the cover and gasket. (Fig. 11)
5. Remove four (4) screws securing the flue pipe to back of the intake box and remove pipe and gasket. (Fig. 11)
6. Secure the plate and gasket removed in Step 4 over the flue opening in the back of the intake box. Ensure the gasket is in place and undamaged.
7. Install the flue pipe and gasket removed in Step 5 over the flue opening in the top of the intake box.
8. Refit the outer collar adapter and gasket to the unit with the round collar on the top. Secure the adapter with the 10 screws removed in Step 1.

When converting the appliance to top vent, ensure the insulation material referred to in Step 3 is completely removed.

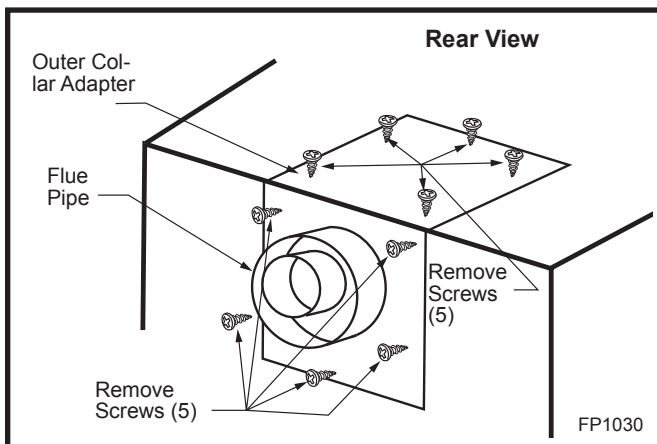

Fig. 9 Remove screws from outer collar adapter.

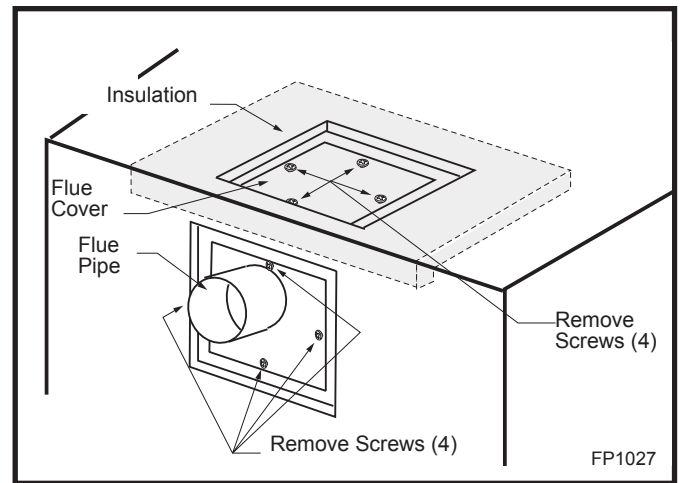

Fig. 10 Remove flue cover and flue pipe.

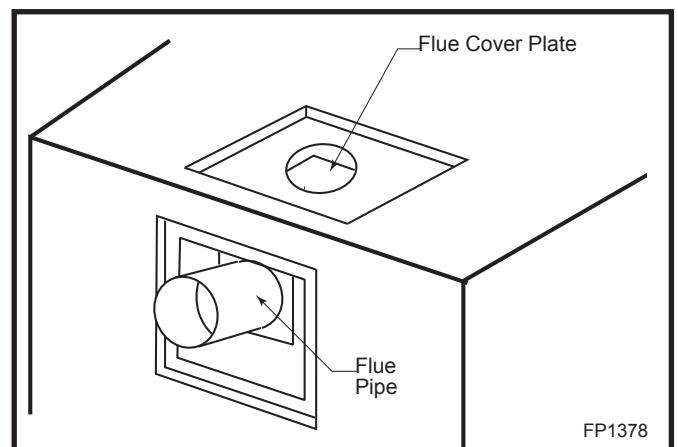

Fig. 11 Remove flue pipe and flue cover plate.

General Venting Information – Termination Location

Your fireplace is approved to be vented either through the rear wall or the vertical side wall, or vertical through the roof.

- Only venting components specifically approved and labeled for this fireplace may be used.
- Venting terminals shall not be recessed into a wall or siding.
- Horizontal venting must be installed on a level plane without any incline or decline.

There must not be any obstruction such as bushes, gar-

den sheds, fences, decks or utility buildings within 24” from the front of the termination hood.

Location of Vent Termination

It is imperative the vent termination be located observing the minimum clearances as shown on this page.

*Check with local codes or in absence of same with CSAB149.1 Installation Codes (1991) for Canada or follow the current National Fuel Gas Code, ANSI Z223.1/ NFPA 54 for installations in the USA.

General Venting Information - Termination Location

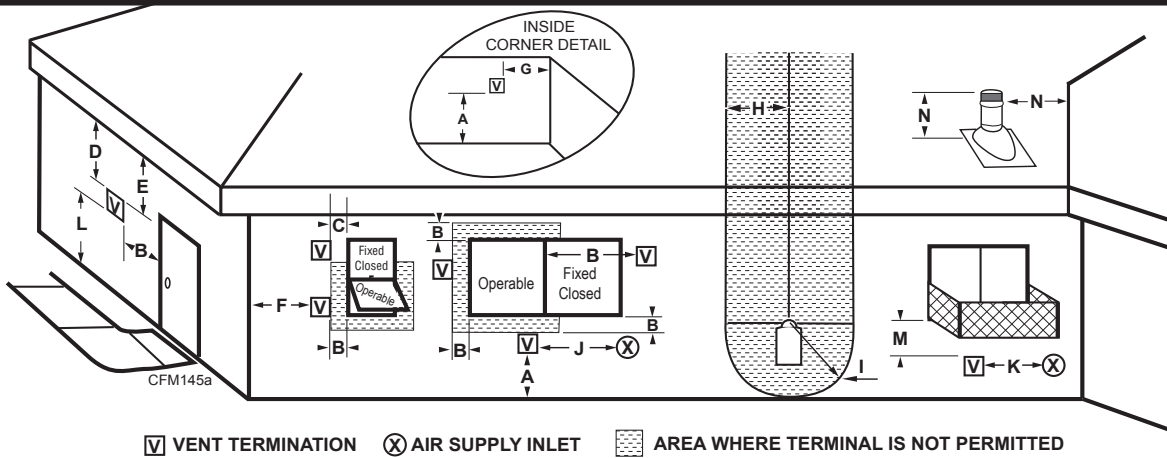

	Canadian Installations ¹	US Installations ²
A = Clearance above grade, veranda, porch, deck, or balcony	12" (30cm)	12" (30cm)
B = Clearance to window or door that may be opened	6" (15cm) for appliances < 10,000Btuh (3kW), 12" (30cm) for appliances > 10,000 Btuh (3kW) and < 100,000 Btuh (30kW), 36" (91cm) for appliances > 100,000 Btuh (30kW)	6" (15cm) for appliances < 10,000 Btuh (3kW), 9" (23cm) for appliances > 10,000 Btuh (3kW) and < 50,000 Btuh (15kW), 12" (30cm) for appliances > 50,000 Btuh (15kW)
C = Clearance to permanently closed window	12" (305mm) recommended to prevent window condensation	12" (305mm) recommended to prevent window condensation
D = Vertical clearance to ventilated soffit located above the terminal within a horizontal distance of 2' (610mm) from the center line of the terminal	18" (458mm)	18" (458mm)
E = Clearance to unventilated soffit	12" (305mm)	12" (305mm)
F = Clearance to outside corner	see next page	see next page
G = Clearance to inside corner (see next page)	see next page	see next page
H = Clearance to each inside of center line extended above meter/regulator assembly	3' (91cm) within a height of 15' (5m) above the meter/regulator assembly	3' (91cm) within a height of 15' (5m) above the meter/regulator assy
I = Clearance to service regulator vent outlet	3' (91cm)	3' (91cm)
J = Clearance to nonmechanical air supply inlet to building or the combustion air inlet to any other appliances	6" (15cm) for appliances < 10,000 Btuh (3kW), 12" (30cm) for appliances > 10,000 Btuh (3kW) and < 100,000 Btuh (30kW), 36" (91cm) for appliances > 100,000 Btuh (30kW)	6" (15cm) for appliances < 10,000 Btuh (3kW), 9" (23cm) for appliances > 10,000 Btuh (3kW) and < 50,000 Btuh (15kW), 12" (30cm) for appliances > 50,000 Btuh (15kW)
K = Clearance to a mechanical air supply inlet	6' (1.83m)	3' (91cm) above if within 10 feet (3m) horizontally
L = Clearance above paved sidewalk or paved driveway located on public property	7' (2.13m)†	7' (2.13m)†
M = Clearance under veranda, porch, deck or balcony	12" (30cm)‡	12" (30cm)‡

N = Clearance above a roof shall extend a minimum of 24" (610mm) above the highest point when it passes through the roof surface, and any other obstruction within a horizontal distance of 18" (450mm).

1 In accordance with the current CSA-B149 Installation Codes
 2 In accordance with the current ANSI Z223.1/NFPA 54 National Fuel Gas Codes
 † A vent shall not terminate directly above a sidewalk or paved driveway which is located between two single family dwellings and serves both dwellings
 ‡ only permitted if veranda, porch, deck or balcony is fully open on a minimum 2 sides beneath the floor:
 NOTE: 1. Local codes or regulations may require different clearances.
 2. The special venting system used on Direct Vent Fireplaces are certified as part of the appliance, with clearances tested and approved by the listing agency.
 3. CFM Corporation assumes no responsibility for the improper performance of the appliance when the venting system does not meet these requirements.

Fig. 12 Termination location requirements.
 10003848

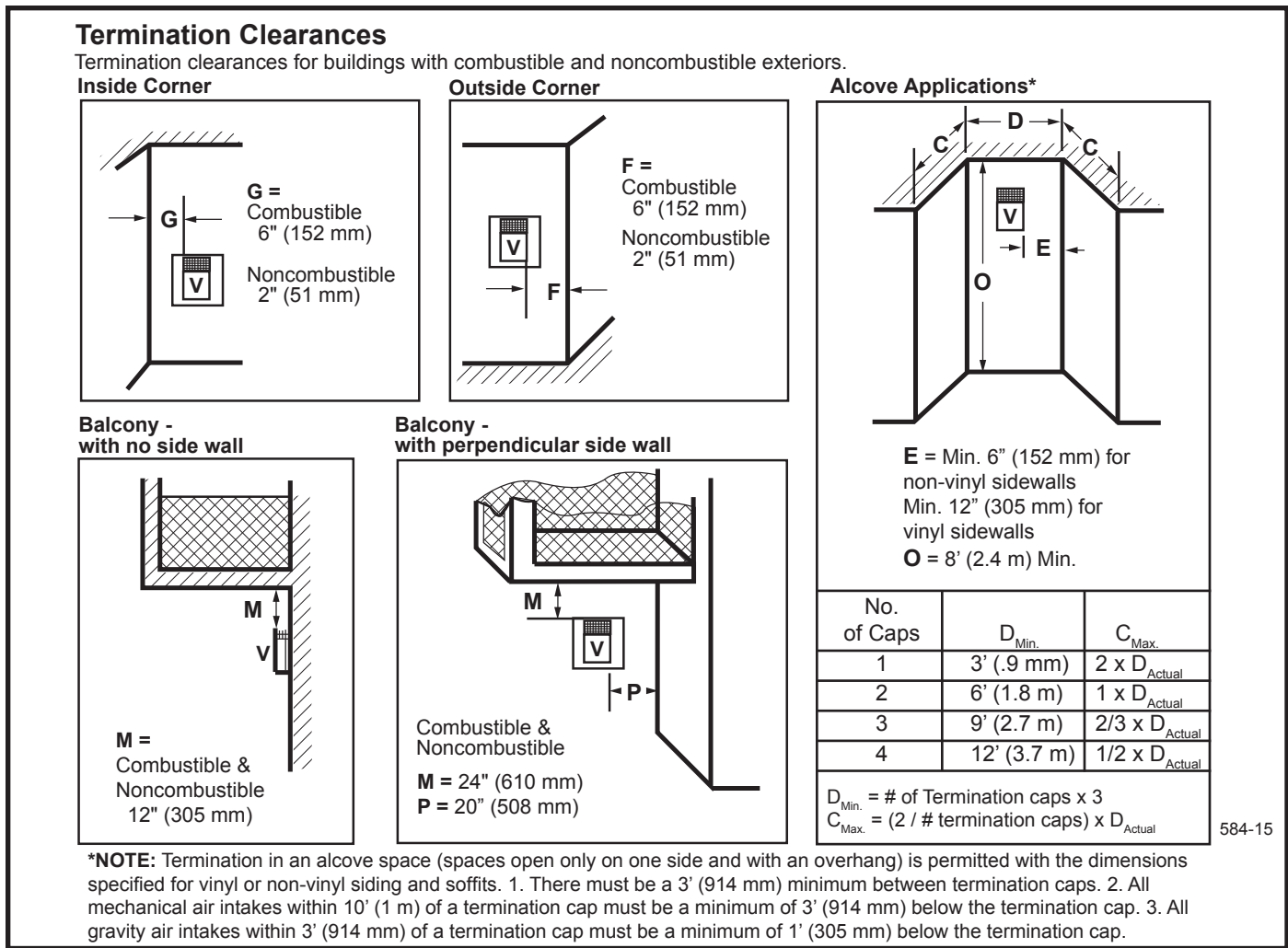

Fig. 12a Termination clearances.

General Information for Connecting Vent Pipes

Canadian Installations:

Venting system must be installed in accordance with the current CSA-B149.1 installation code.

USA Installations:

The venting system must conform with local codes and/or the current National Fuel Gas code ANSI Z223.1/ NFPA 54.

Only direct vent components manufactured by CFM Corporation can be used in Direct Vent systems.

To join the twist lock pipes together, simply align the beads of the male end with the grooves of the female end, twisting the pipe until the flange on the female end contacts the external flange on the male end. It is recommended that you secure the joints with three (3) sheet metal screws, however this is not mandatory with twist lock pipe.

NOTE: For ease of assembly, use a lubricant (Vaseline or similar substance) on male end of twist lock pipe prior to assembly.

Twist Lock Pipes

When using CFM Corporation twist-lock pipe it is not necessary to use sealant on the joints. The only areas of the venting system that need to be sealed with high temperature silicone sealant are the sliding joints of any telescopic vent section used in the system.

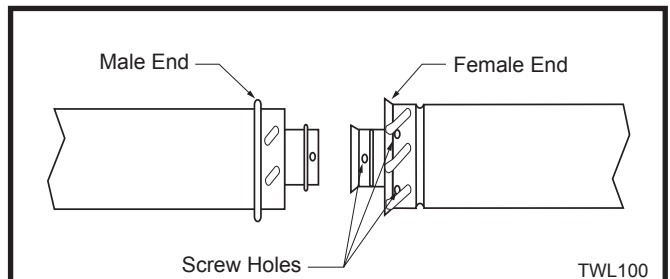

Fig. 14 Twist-lock pipe joints.

How to Use the Vent Graph

The vent chart should be read in conjunction with the following vent installation instructions to determine the relationship of the vertical and horizontal dimensions of the vent system.

1. Determine the height of the center of the horizontal vent pipe exiting through the outer wall. Using this dimension on the Sidewall Vent Graph, (Fig. 15) locate the point intersecting with slanted graph line.
2. From the point of this intersection, draw a vertical line to the bottom of the graph.
3. Select the indicated dimension, and position the fireplace in accordance with same.

Example A:

If the vertical dimension from the floor of the fireplace is 11' (3.4 m) the horizontal run to the face of the outer wall must not exceed 14' (4.3 m).

Example B:

If the vertical dimension from the floor of the unit is 7' (2.14 m), the horizontal run to the face of the outer wall must not exceed 8½' (2.6 m).

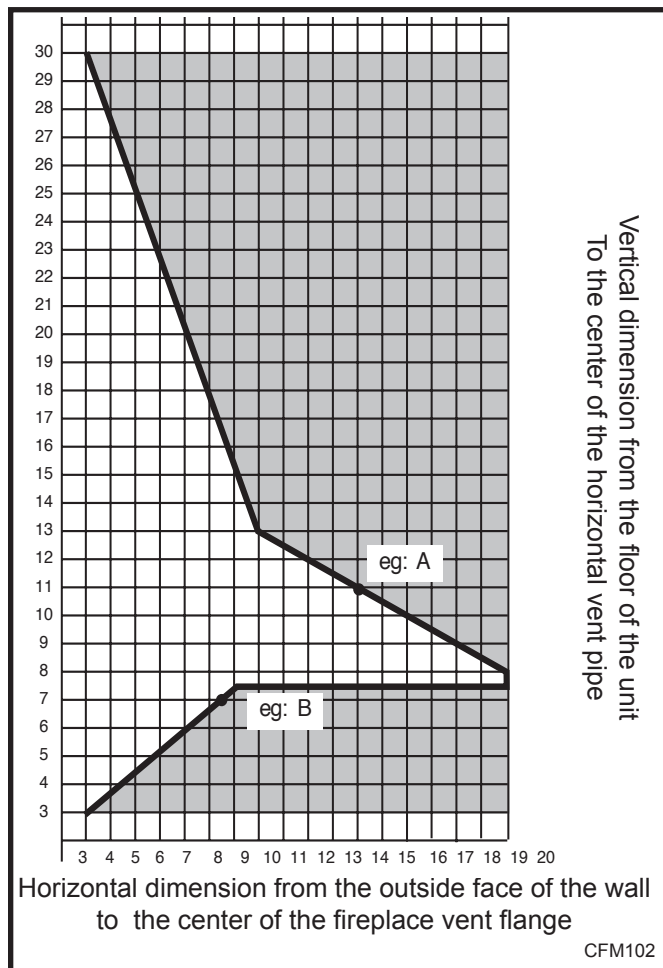

Fig. 15 Sidewall vent graph showing the relationship between vertical and horizontal dimensions for a Direct Vent flue system.

Rear Wall Vent Applications

When installed as a rear vent unit this appliance may be vented directly to a termination located on the rear wall behind the appliance.

- Specific rear vent starter kits must be used in these applications (see 'Venting Components'). The appliance has been approved for installation flat against a rear wall. (Fig. 16)
- The maximum horizontal distance between the rear of the appliance and the outside face of the rear wall is 20" (508mm). (Fig. 16)
- The minimum clearances between any combustible material and the vent pipe sections are:
 Top 2" (51 mm)
 Sides 1" (25 mm)
 Bottom..... 1" (25 mm)

When the vent termination is installed in an accessible location, a Screen Guard Kit, item #7V1B60, should be installed. (Accessible means the termination is likely to be touched)

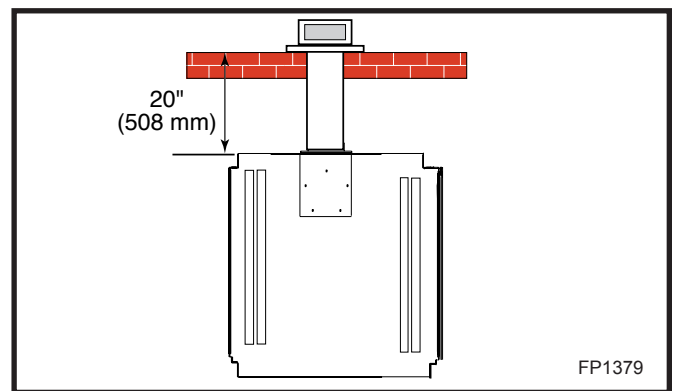

Fig. 16 Rear vent application, no elbows.

Rear Wall Vent Installation

STEP 1

Locate and cut the vent opening in the wall. (Fig. 17) For combustible walls first frame in opening. (Fig. 17)

Combustible Walls: Cut a 10⅝" H x 9⅞" W (265 x 240mm) hole through the exterior wall and frame. (Fig.21)

Noncombustible Walls: Hole opening must be 7½" (190 mm) in diameter.

STEP 2

Measure wall thickness and cut zero clearance sleeve parts to proper length (MAXIMUM 12"/305 mm). Assemble sleeve to its maximum opening (10⅝" x 9⅞") and attach to firestop with #8 sheet metal screws (supplied). Install firestop assembly. (Fig. 18)

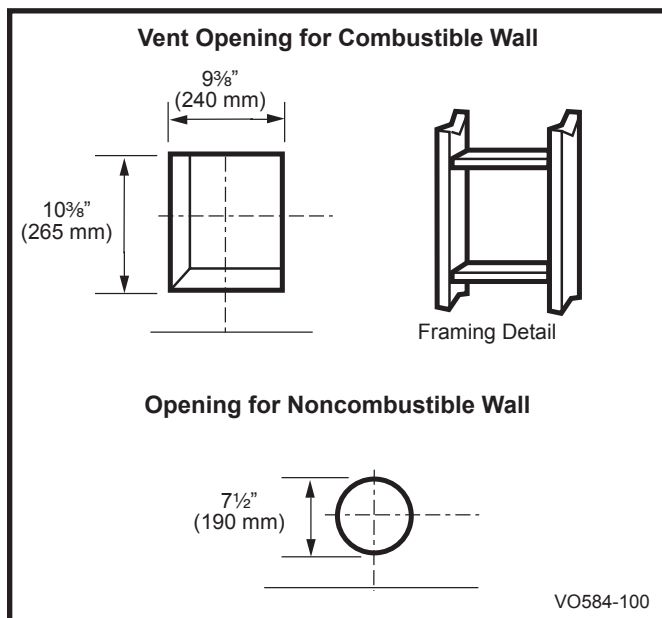

Fig. 17 Locate vent opening on wall.

Zero clearance sleeve is only required for combustible walls.

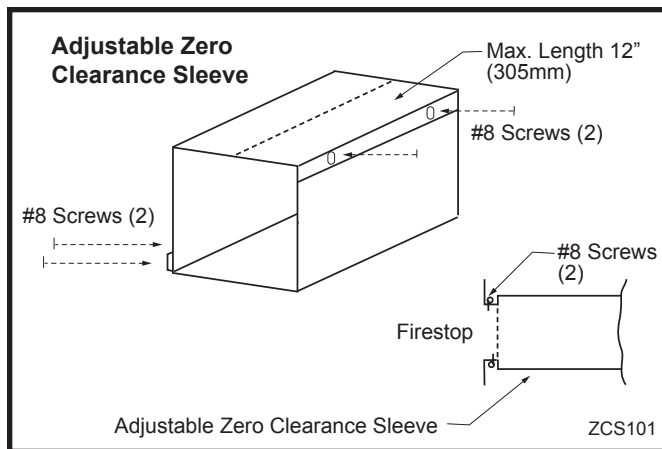

Fig. 18 Adjustable zero clearance sleeve.

STEP 3

Measure the horizontal length requirement for the venting including a 2" (51 mm) overlap, i.e. from the elbow to the outside wall face plus 2" (51 mm) (or the distance required if installing a second 90° elbow. (Fig. 17)

STEP 4

Install the 4" (102 mm) vent to the appliance collar and secure with three (3) sheetmetal screws. Install the 7" (175 mm) vent pipe to the appliance collar and secure with three (3) sheet metal screws. It is not necessary to seal this connection.

It is critical that there is no downward slope away from the appliance when connecting the vent or elbow.

STEP 5

Guide the vent through the vent hole as you place the appliance in its installed position. Guide the 4" (102mm) and 7" (175 mm) collars of the vent termination into the outer ends of the venting. Do not force the termination. If the vent pipes do not align with the termination remove and realign the venting at the appliance flue collars. Attach the termination to the wall as outlined in the instruction sheet supplied with the termination.

Vertical Sidewall Applications

Since it is very important the venting system maintain its balance between the combustion air intake and the flue gas exhaust, certain limitations as to vent configurations apply and must be strictly adhered to.

The vent graph showing the relationship between vertical and horizontal side wall venting will help to determine the various dimensions allowable.

Minimum clearance between vent pipes and combustible materials is one 1" (25mm) on top, bottom and sides unless otherwise noted.

When the vent termination exits through foundations less than 20" (508 mm) below siding outcrop, the vent pipe must flush up with the siding.

It is always best to locate the fireplace in such a way that minimizes the number of offsets and horizontal vent length of vent pipe from the flue collar of the fireplace to the face of the outer wall.

Horizontal plane means no vertical rise exists on this portion of the vent assembly.

When installing the appliance as a rear vent unit the 90° Transition Elbow attached directly to the rear of the unit is not included in the following criteria and calculations, and unless specifically mentioned should be ignored when calculating venting layouts.

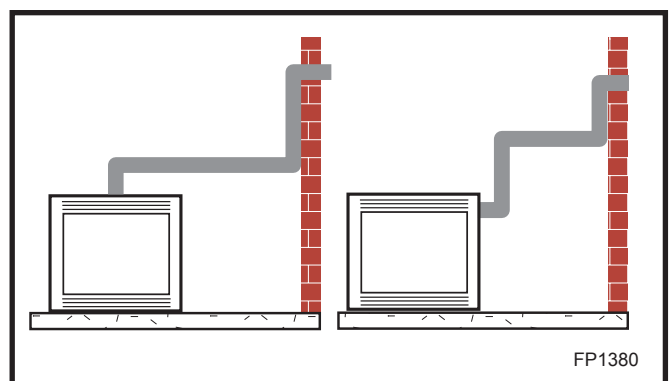

Fig. 19 Maximum number of 90° elbows per sidewall.

- The maximum number of 90° elbows per side wall installation is three (3).
- If a 90° elbow is fitted directly on top of the fireplace flange, the maximum horizontal vent run before the termination or a vertical rise is 36" (914 mm).

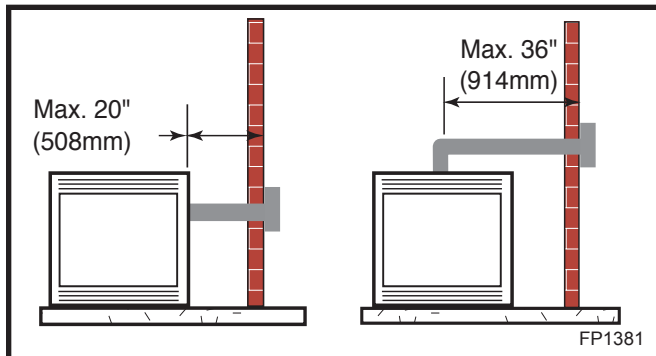

Fig. 20 Maximum horizontal vent run.

- If a 90° elbow is used in the horizontal vent run (level height maintained) the maximum horizontal vent length is reduced by 36" (914 mm). (Fig. 21) This does not apply if the 90° elbows are used to increase or redirect a vertical rise. (Fig. 21)

Example: According to the chart the maximum horizontal vent length in a system with a 7.5' vertical rise is 20' (6 m) and if a 90° is required in the horizontal vent it must be reduced to 17' (5.2 m).

Dimension A plus B must not be greater than 17' (5.2m). (Fig. 21)

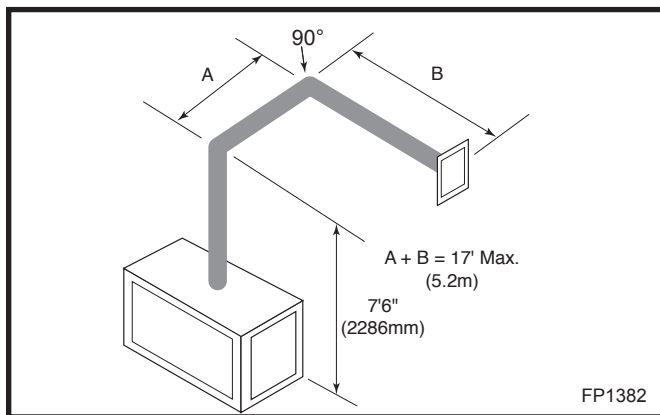

Fig. 21 Maximum vent run with elbows.

- The maximum number of 45° elbows permitted per side wall installation is two (2). These elbows can be installed in either the vertical or horizontal run.
- For each 45° elbow installed in the horizontal run, the length of the horizontal run MUST be reduced by 18" (45cm). This does not apply if the 45° elbows are installed in the vertical part of the vent system.
- The maximum number of elbow degrees in a system is 270°. (Fig. 22)

Example: In Fig. 22

Elbow 1 = 90°

Elbow 2 = 45°

Elbow 3 = 45°

Elbow 4 = 90°

Total Angular Variation = 270°

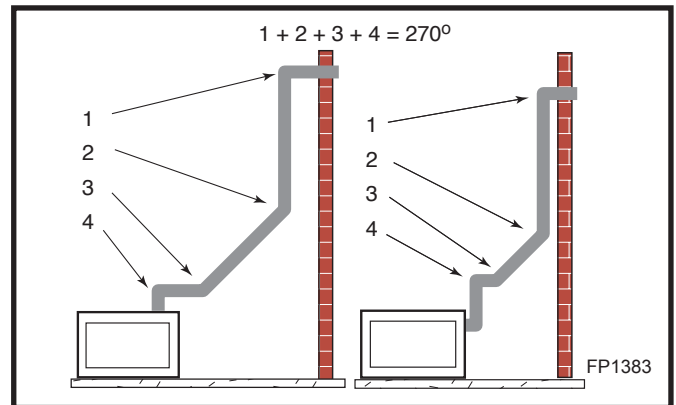

Fig. 22 Maximum number of elbows allowed.

Vertical Sidewall Installation

STEP 1

Locate vent opening on the wall. It may be necessary to first position the fireplace and measure to obtain hole location. Depending on whether the wall is combustible or noncombustible, cut opening to size. (Fig. 23) For combustible walls first frame in opening. (Fig. 23)

Combustible Walls: Cut a 9 3/8" H x 9 3/8" W (240 x 240mm) hole through the exterior wall and frame as shown in Figure 23.

Noncombustible Walls (Fig. 23): Hole opening must be 7 1/2" (190 mm) in diameter.

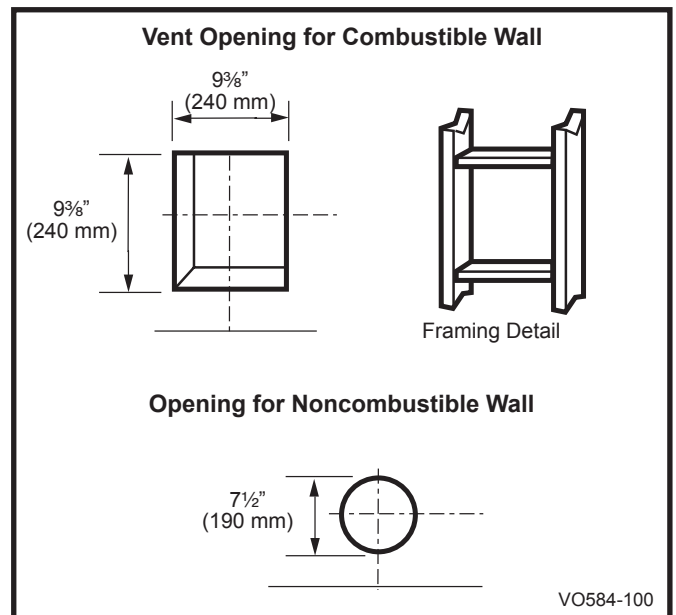

Fig. 23 Locate vent opening on wall.

STEP 2

Measure wall thickness and cut zero clearance sleeve parts to proper length (MAXIMUM 12"/305 mm). Assemble sleeve and attach to firestop with #8 sheet metal screws (supplied). Install firestop assembly. (Fig. 24)



Zero clearance sleeve is only required for combustible walls.

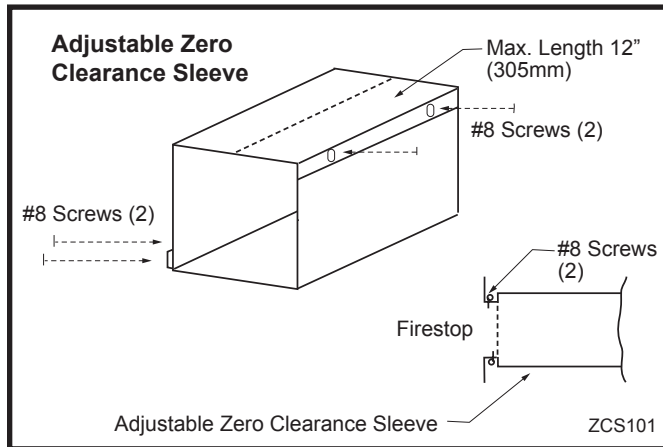

Fig. 24 Adjustable zero clearance sleeve.

STEP 3

Place fireplace into position. (Fig. 25) Measure the vertical height (X) required from the base of the flue collars to the center of the wall opening.

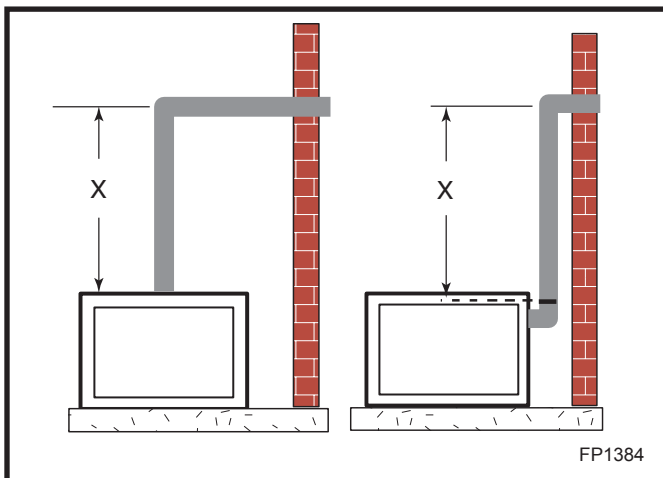

Fig. 25 Vertical height requirements.

STEP 4

Apply a bead of silicone to the inner and outer flue collars of the fireplace and using appropriate length of pipe section(s) attach to fireplace with three (3) screws. Follow with the installation of the inner and outer elbow, again secure joints as described in "Connecting Vent Pipes".

STEP 5

Measure the horizontal length requirement including a 2" (51 mm) overlap, i.e. from the elbow to the outside wall face plus 2" (51 mm) (or the distance required if installing a second 90° elbow. (Fig. 26)



Always install horizontal venting on a level plane.

STEP 6

Use appropriate length of pipe sections - telescopic or fixed and install. The section which goes through the wall is packaged with the starter kit, and can be cut to suit if necessary.

Sealing vent pipe and firestop gaps with high temperature sealant will restrict cold air being drawn in around fireplace.

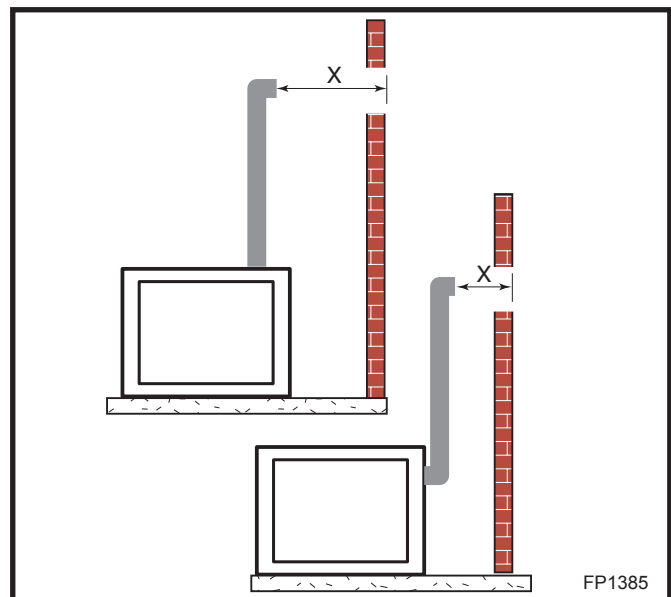

Fig. 26 Horizontal length requirement.

STEP 7

Apply high temperature sealant to 4" (100mm) and 7" (175mm) collars or the termination one inch away from crimped end. Guide the vent terminations 4" and 7" collars into their respective vent pipes. Double check that the vent pipes overlap the collars by 2" (50mm). Secure the termination to the wall with screws provided and caulk around the wall plate to weatherproof.

Support the horizontal pipes every 36" (914mm) with metal pipe straps.

Check the fireplace to make sure that it is levelled and properly positioned.

Below Grade Installation

When it is not possible to meet the required vent terminal clearances of 12" (305 mm) above grade level a starter kit is recommended. It allows installation depth of down to 7" (178 mm) below grade level. The 7" (178mm) is measured from the center of the horizontal vent pipe as it penetrates through the wall.

If venting system is installed below ground, we recommend a window well with adequate and proper drainage.

Ensure sidewall venting clearances are observed.

If installing a snorkel, a minimum 24" (610mm) vertical rise is necessary. The maximum horizontal run with the 24" (610mm) vertical pipe is 36" (914mm). The measurement is taken from the collar of the fireplace (or transition elbow) to the face of the exterior wall. See Vent Chart (see 'How to use the Vent Graph') for extended horizontal runs if the vertical exceeds 24" (610mm).

1. Establish vent hole through the wall. (Fig. 23)
2. Remove soil to a depth of approximately 16" (406mm) below base of snorkel. Install drain pipe. Install window well (not supplied). Refill hole with 12" (305mm) of coarse gravel leaving a clearance of approximately 4" (100mm) below snorkel. (Fig. 27)
3. Install vent system.
4. Ensure a watertight seal is made around the vent pipe coming through the wall.
5. Apply high temperature sealant caulking (supplied) around the 4" and 7" snorkel collars.
6. Slide the snorkel into the vent pipes and secure to the wall.
7. Level the soil so as to maintain a 4" (100mm) clearance below snorkel. (Fig. 27)

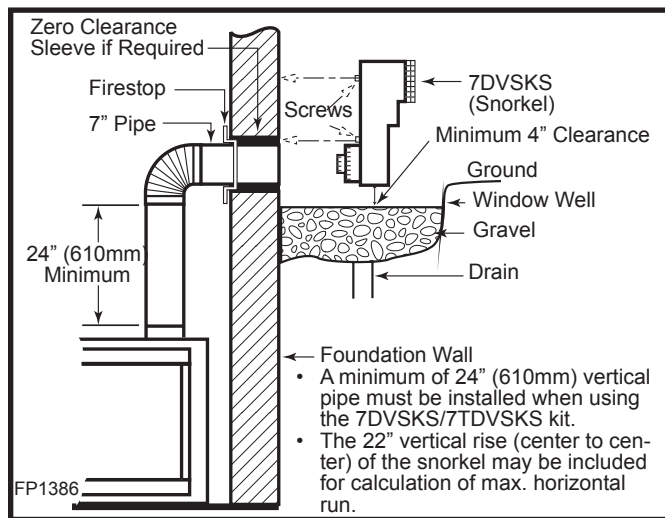

Fig. 27 Below grade installation.



Do not back fill around snorkel.

A clearance of at least 4" (100mm) must be maintained between the snorkel and the soil.

If the foundation is recessed, use recess brackets (not supplied) for securing lower portion of the snorkel. Fasten brackets to wall first, then secure to snorkel with self drilling #8 x 1/2 sheetmetal screws. It will be necessary to extend vent pipes out as far as protruding wall face. (Fig. 28)

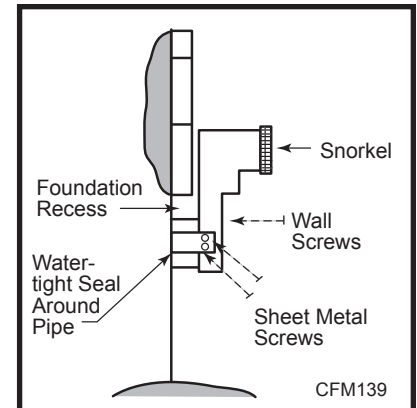

Fig. 28 Snorkel installation, recessed foundation.

Vertical Through-the-Roof Applications

This Gas Fireplace has been approved for:

- Vertical installations up to 40' (12 m) in height. Up to a 10' (3 m) horizontal vent run can be installed within the vent system using a maximum of two 90° elbows. (Fig. 29 & 30)
- Up to two (2) 45° elbows may be used within the horizontal run. For each 45° elbow used on the horizontal level the maximum horizontal length must be reduced by 18" (457 mm).

Example: Maximum horizontal length

- 0 x 45° elbows = 10' (3 m)
- 1 x 45° elbows = 8.5' (2.6 m)
- 2 x 45° elbows = 7' (2.1 m)

- A minimum of an 8' (2.4 m) vertical rise.
- A maximum of two (2) sets of 45° elbow offsets can be used within these vertical installation. From 0 to a maximum of 8' of vent pipe can be used between elbows. (Fig. 30)
- 7DVCS supports offsets. (Fig. 32) This application will require that you first determine the roof pitch and use the appropriate starter kit. (See Venting Components List)
- The maximum angular variation allowed in the system is 270°. (Fig. 30)

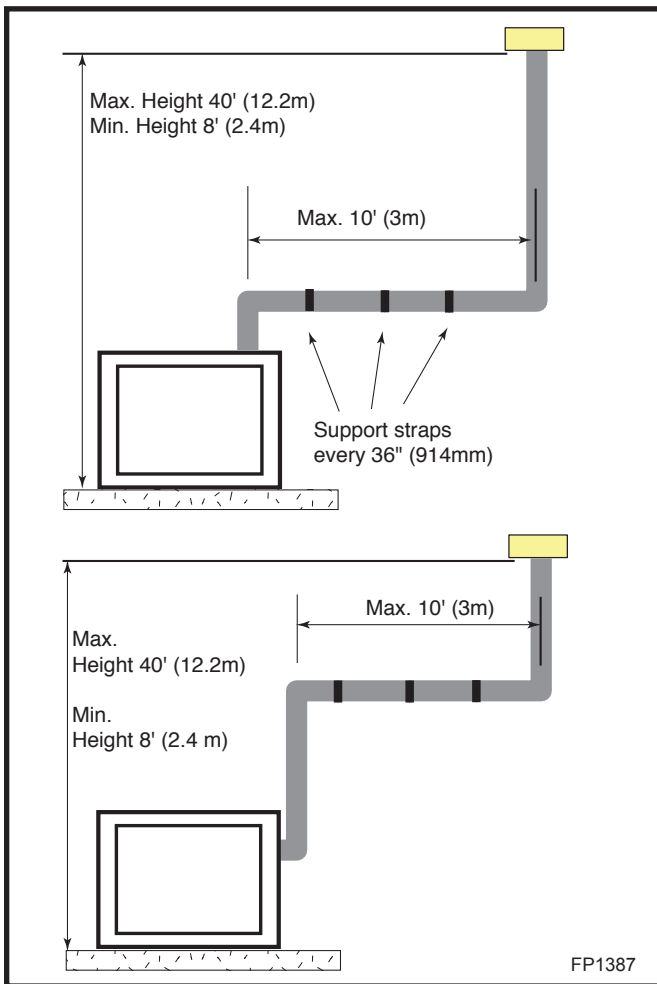

Fig. 29 Support for horizontal runs.

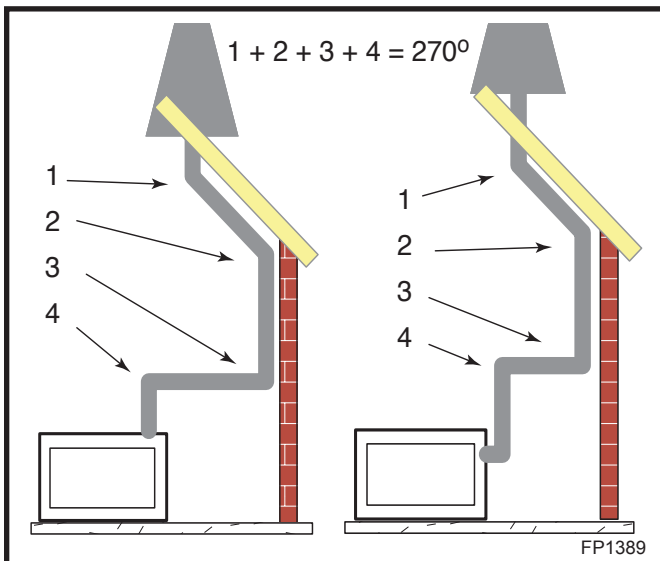

Fig. 30 Maximum elbow usage.

- The minimum height of the vent above the highest point of penetration through the roof is 24" (610 mm) (Fig. 31)

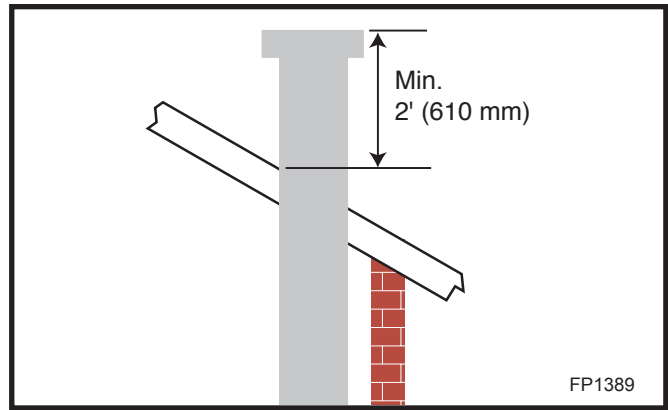

Fig. 31 Minimum termination to roof clearance.

Vertical Through-The-Roof Installation

1. Locate your fireplace.
2. Plumb to center of the (4") flue collar from ceiling above and mark position.
3. Cut opening equal to 9 $\frac{3}{8}$ " x 9 $\frac{3}{8}$ " (240 x 240 mm).
4. Proceed to plumb for additional openings through the roof. In all cases, the opening must provide a minimum of 1" (25 mm) clearance to the vent pipe, i.e., the hole must be at least 9 $\frac{3}{8}$ " x 9 $\frac{3}{8}$ " (240 x 240mm).
5. Place fireplace into position.
6. Place firestop(s) #7DVFS or Attic Insulation Shield #7DVAIS into position and secure. (Fig. 34)
7. Install roof support (Fig. 32) and roof flashing making sure upper flange is below the shingles. (Fig. 33)
8. Install appropriate pipe sections until the venting is above the flashing. (Fig. 33)
9. Install storm collar and seal around the pipe. (Fig. 33)
10. Add additional vent lengths for proper height. (Fig. 31)
11. Apply high temperature sealant to 4" and 7" collars of vertical vent termination and install.

The enlarged ends of the vent section always face downward.

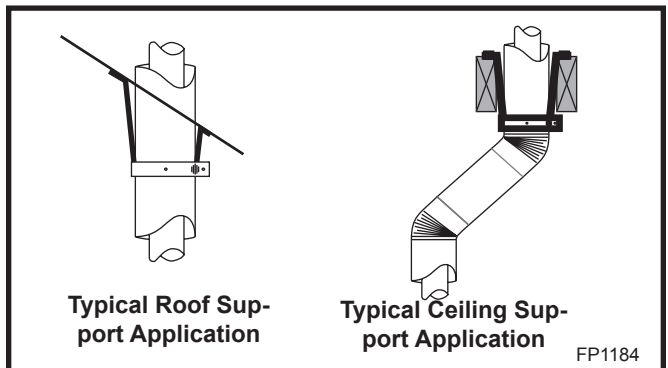

Fig. 32 Venting supports.

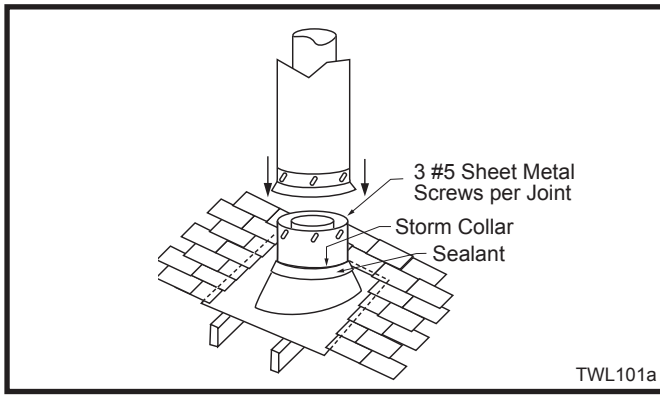

Fig. 33 Roof flashing.



If there is a room above ceiling level, firestop spacer must be installed on both the bottom and the top side of the ceiling joists. (Fig. 34) If an attic is above ceiling level a 7DVAIS (Attic Insulation Shield) must be installed.

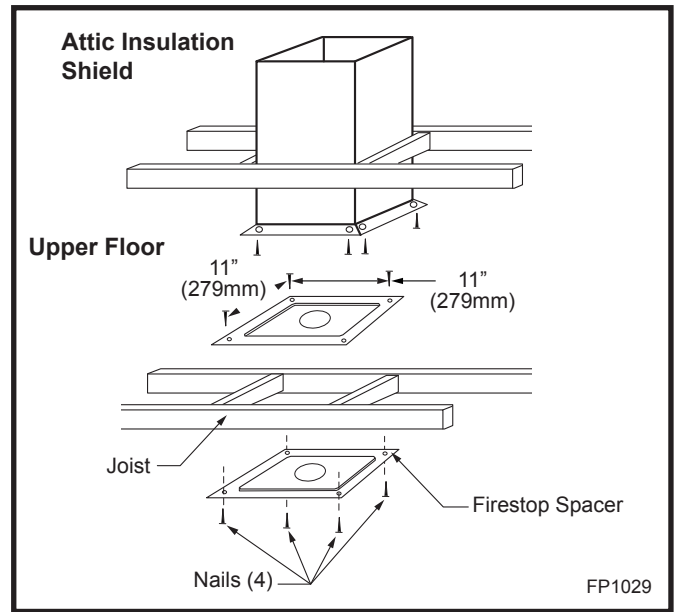
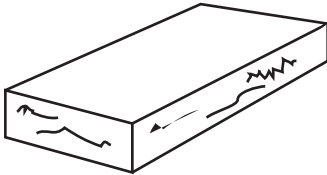

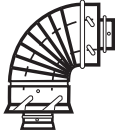
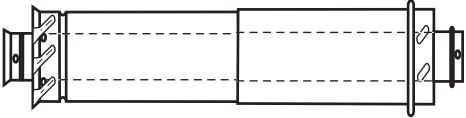
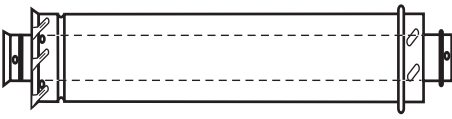
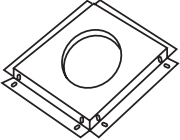





Fig. 34 Attic insulation shield and firestop spacer installation.

Twist Lock Venting Components

	<p>Starter Kit-Model 7TDVSK-Sidewall/Rearwall Venting Starter Kit-Model 7TDVSKV-Vertical Venting for 7TDVSKV-A order 1/12 to 6/12 roof pitch for 7TDVSKV-B order 7/12 to 12/12 roof pitch for 7TDSKV-F order flat roof Starter Kit-Model 7TDVSKS-Snorkel Kit for Below Grade Installation</p>
	<p>45° Elbow 7TDV45 for Rear Vent to Vertical Vent or Vertical/Horizontal Offsets</p>
	<p>90° Transition Elbow 7TDVRT90 for Rear Vent to Vertical Vent 90° Elbow 7TDV90 Vertical/Horizontal Offset</p>
	<p>Telescopic vent sections 7TDVP1218 -12" to 18" adjustable length 7TDVP3564 -35" to 64" adjustable length</p>
	<p>Pipe sections for vertical or horizontal venting Model 7TDVP8" 4 per box Model 7TDVP12" 4 per box Model 7TDVP24" 4 per box Model 7TDVP36" 4 per box Model 7TDVP48"</p>
	<p>Firestop Spacer Model 7DVFS</p>
	<p>Attic Insulation Shield Model 7DVAIS</p>
	<p>Vertical/Horizontal Combination Offset Support Model 7DVCS</p>
	<p>7TBSG 7" T.L. DVRTSB Termination Screen Guard Kit</p>

Operating Instructions

Glass Information

Only glass approved by CFM Corporation should be used on this fireplace.

- The use of any non-approved replacement glass will void all product warranties.
- Care must be taken to avoid breakage of the glass.
- Under no circumstances should this appliance be operated without the front glass in place, or with the glass in a damaged condition.
- Replacement glass (complete with gasket) is available through your Majestic Fireplaces dealer and should only be installed by a licensed qualified service person.

Louvre Removal

- The top side and top end louvres are removed by simply lifting the louvre assembly and pulling the assembly away from the fireplace. (Fig. 35)
- The lower side louvres are hinged along the lower edge and are folded down for access to components in the base cavity of the fireplace.
- The lower end louvre assemblies on the DVRTSB unit are removed in the same manner as the top louvre assemblies.

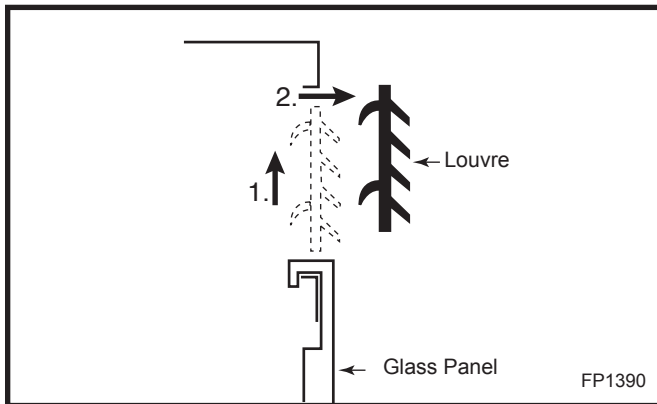

Fig. 35 Louvre removal.

Glass/Frame Removal

Front Glass Frame

1. Shut off the gas supply.
2. Allow the fireplace to cool if it has been in operation.
3. Remove the top louvre assembly.
4. Lower the bottom louvre assembly.
5. Release the two clamps along lower edge of the frame by pulling down on clamp handles. (Fig. 36)

6. Tilt the lower edge of frame out slightly and lift glass/frame assembly up and away from the fireplace. (Fig. 36)
7. To reinstall the glass panel reverse this procedure.

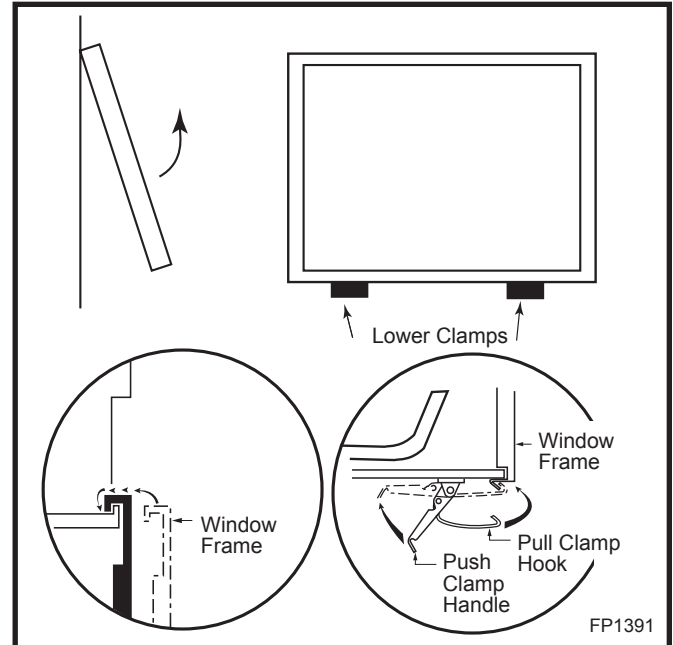

Fig. 36 Remove glass/frame assembly.

Side Glass Frame

1. Remove the top and bottom louvre assemblies.
2. Remove the lower window trim (held in place with magnets).
3. Remove both lower retaining screws. Access to these screws is gained through the holes along the lower edge of the frame behind the trim. (Fig. 37)
4. Tilt lower edge of frame out slightly and lift glass/frame assembly up and away from the fireplace.
5. To reinstall the glass panel reverse the process.

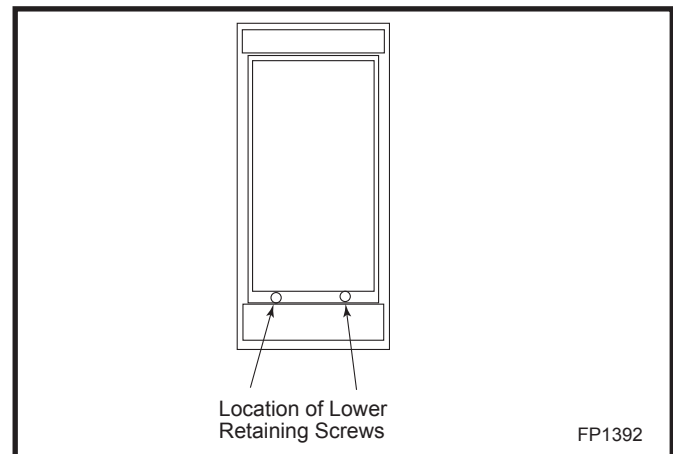

Fig. 37 Remove end glass.

Glass Cleaning

It is necessary to periodically clean glass. During start-up condensation, which is normal, forms on the inside of the glass. This condensation causes lint, dust and other airborne particles to cling to glass surface.

Also initial paint curing may deposit a slight film on the glass. It is therefore recommended glass be cleaned two or three times with a non-ammonia based household cleaner and warm water (We recommend gas fireplace glass cleaner) within the first few weeks of operation.

After the initial cleaning process the glass should be cleaned two or three times during each operating season depending on the environment in the house.



Clean the glass after the first two weeks of operation.

Ceramic Refractory Installation

The rear wall refractory panels are installed in the unit prior to shipment.

1. Unpack the ceramic refractory panels from their carton.



Handle the refractory material carefully, the panels are fragile.

2. Place the front floor refractory panels on the base of the fireplace. (Fig. 38)
3. Place both side panels in place along the side of the base. (Fig. 38)

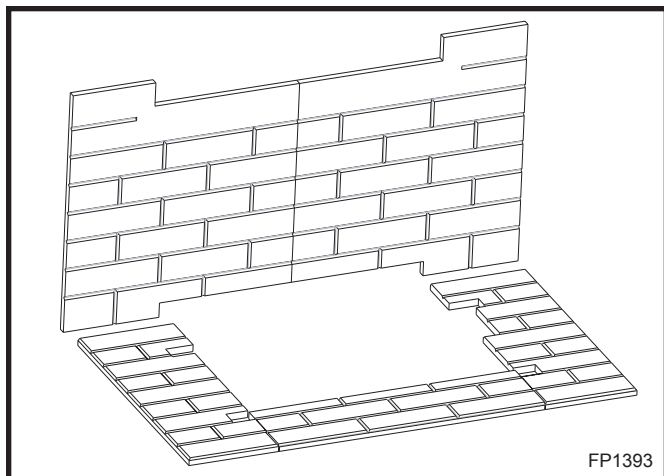

Fig. 38 DVRTSB ceramic panels.

Installation of Logs

The logs can be identified by the number cast into their underside.

The logs must be correctly placed in the order described for the correct operation of the fireplace.

Refer to Figures 30 & 40 for log location and alignment.

1. Unpack the logs from the shipping carton. **Handle the logs carefully as they are fragile.**



Handle and dispose of the plastic bags in a safe manner. They are not toys and should be kept away from infants.

2. Remove front glass/frame assembly.
3. Place the left rear (B105) and right rear (B106) logs in place on the grate. The square hole in the underside of the logs locates over the corner legs of the grate. The inner ends of the log point to the center of the burner.
4. Place the left front (B107) and right front (B108) logs in place. Again the square holes fit over the corner legs of the grate. The inner ends of these logs have a recess in the underside which locates over knobs on the top of the B105 and B106 logs to lock the inner end in place.
5. Place the center front (B109) log in place. The notch on the outer end of this log locates around the third outer prong on the grate and the inner ends with a round recess rest on lug on top of the left front log (B107).
6. Place the center rear (B110) log in place. The square hole in the underside of this log, locates over the rear center bar of the grate. The inner end of the log having a rectangular recess rests on the rectangular knob on the end of the left front log, (B107).

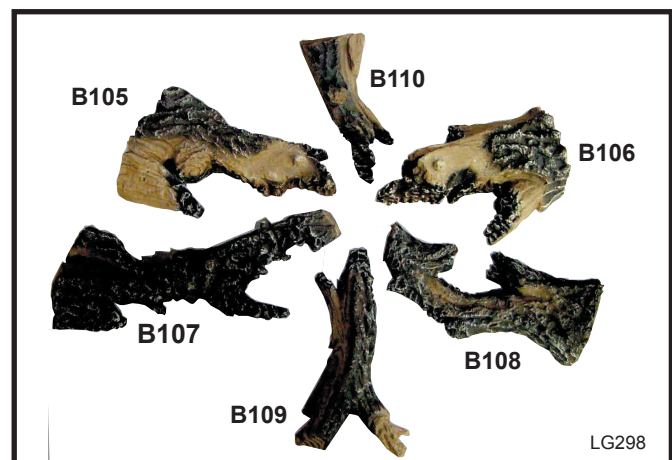

Fig. 39 DVRTSB logs.

Lava Rock & Ember Material

Your log set contains two types of "Lava Rocks".

The placement of this material is best done after the logs have been installed.

Ceramic Ember Rocks (Pt. # 57897)

Remove these 'rocks' from the packaging and spread them over the burner tiles in a random fashion to fill up the spaces between the logs. (Fig. 40) Only place ceramic embers in areas shown in Figure 40.

Lava Rock (Pt.# 10001454)

Remove this material from the packaging and spread it over the ceramic floor panels outside the log stack. **DO NOT PLACE THIS MATERIAL ON THE BURNER TILES.**

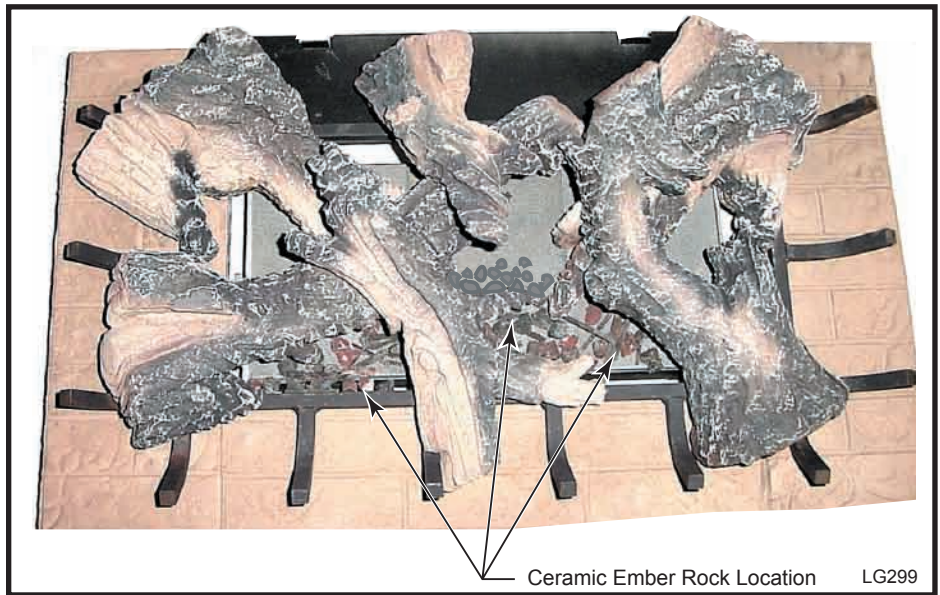

Fig. 40 Location of log cradle prongs in relation to assembled logs.

Flame & Temperature Adjustment

RN/RP Models

For units equipped with 'HI/LO' valves the flame adjustment is accomplished by rotating the 'HI/LO' adjustments knob located near the center of the gas control valve. (Figs. 41 & 42)



Fig. 41 Flame adjustment knob for Honeywell valve.

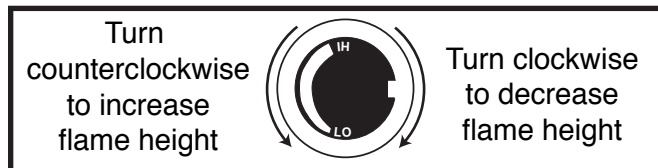

Fig. 42 Flame adjustment knob for SIT valve.

Flame Characteristics

It is important to periodically perform a visual check of the pilot and burner flames. Compare to the illustrations below. (Figs. 43 & 44) If the flame patterns appear abnormal contact a qualified service provider for service and adjustment.

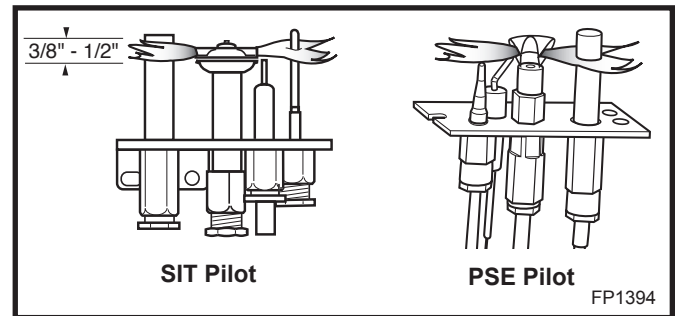

Fig. 43 Correct pilot flame appearance.



Fig. 44 Correct burner flame appearance.

Lighting and Operating Instructions

FOR YOUR SAFETY READ BEFORE LIGHTING

WARNING: If you do not follow these instructions exactly, a fire or explosion may result causing property damage, personal injury or loss of life.

- A. This heater has a pilot which must be lit manually. When lighting the pilot follow these instructions exactly.
- B. BEFORE LIGHTING smell all around the heater area for gas. Be sure to smell next to the floor because some gas is heavier than air and will settle on the floor.

WHAT TO DO IF YOU SMELL GAS

- Do not try to light any fireplace
- Do not touch any electric switch
- Do not use any phone in your building
- Immediately call your gas supplier from a neighbor's phone. Follow the gas supplier's

instructions.

- If you cannot reach your gas supplier, call the Fire Department
- C. Use only your hand to push in or turn the gas control knob. Never use tools. If the knob will not push in or turn by hand, do not try to repair it, call a qualified service technician. Applying force or any attempted repair may result in a fire or explosion.
- D. Do not use this fireplace if any part has been under water. Immediately call a qualified service technician to inspect the heater and to replace any part of the control system and any gas control which has been under water.

Lighting Instructions

1. **STOP!** Read the safety information above.
2. Turn off all electrical power to the fireplace.
3. For MN/MP/TN/TP appliances ONLY, go on to Step 4. For RN/RP appliances turn the On/Off switch to "OFF" position or set thermostat to lowest level.
4. Open control access panel.
5. Push in gas control knob slightly and turn clockwise  to "OFF".

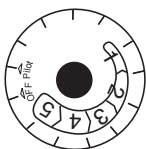

Euro SIT

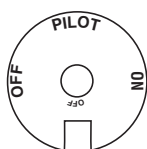

SIT NOVA



Honeywell

6. Wait five (5) minutes to clear out any gas. Then smell for gas, including near the floor. If you smell gas, STOP! Follow "B" in the safety information above. If you do not smell gas, go to the next step.
7. Remove glass door before lighting pilot. (Refer to Glass Frame Removal section).
8. Visibly locate pilot by the main burner.
9. Turn knob on gas control counterclockwise  to "PILOT".

10. Push the control knob all the way in and hold. Immediately light the pilot by repeatedly depressing the piezo spark ignitor until a flame appears. Continue to hold the control knob in for about one (1) minute after the pilot is lit. Release knob and it will pop back up. Pilot should remain lit. If it goes out, repeat steps 5 through 8.

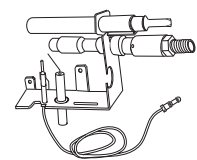
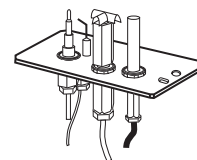
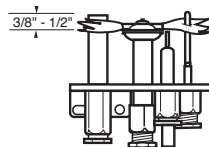

- If knob does not pop up when released, stop and immediately call your service technician or gas supplier.
- If after several tries, the pilot will not stay lit, turn the gas control knob to "OFF" and call your service technician or gas supplier.
- 11. Replace glass door.
- 12. Turn gas control knob to "ON" position.
- 13. For RN/RP appliances turn the On/Off switch to "ON" position or set thermostat to desired setting.
- 14. Turn on all electrical power to the fireplace.

To Turn Off Gas To Heater

1. Turn the On/Off switch to Off position or set the thermostat to lowest setting.
2. Turn off all electric power to the fireplace if service is to be performed.
3. Open control access panel.
4. Push in gas control knob slightly and turn clockwise  to "OFF". Do not force.
5. Close control access panel.

Troubleshooting the Gas Control System

SIT NOVA 820 Millivolt Valve

NOTE: Before trouble shooting the gas control system, be sure external gas shut off is in the “On” position.

WARNING: Before doing any gas control service work, remove glass front.

Symptom	Possible Causes	Corrective Action
1. Spark ignitor will not light	A. Defective or misaligned electrode at pilot.	Using a match, light pilot. If pilot lights, turn off pilot and push the red button again. If pilot will not light - check gap at electrode and pilot-should be 1/8” to have a strong spark.
	B. Defective ignitor (Push Button)	Push Piezo Ignitor Button. Check for spark at electrode and pilot. If no spark to pilot, and electrode wire is properly connected, replace ignitor.
2. Pilot will not stay lit after carefully following lighting instructions.	A. Defective pilot generator (thermocouple), remote wall switch.	Check pilot flame. Must impinge on thermocouple/thermopile. Note: this pilot burner assembly utilizes both-a thermocouple and a thermopile. The thermocouple operates the main valve operation (On and Off). Clean and or adjust pilot for maximum flame impingement on thermopile and thermocouple.
	B. Defective automatic valve	Turn valve knob to “Pilot”. Maintain flow to pilot; millivolt meter should read greater than 10 mV. If the reading is okay and the pilot does not stay on, replace the gas valve. Note: An interrupter block (not supplied) must be used to conduct this test.
3. Pilot burning, no gas to main burner	A. Wall switch or wires defective	Check wall switch and wires for proper connections. Jumper wire across terminals at wall switch, if burner comes on, replace defective wall switch. If okay, jumper wires across wall switch wires at valve, if burner comes on, wires are faulty or connections are bad.
	B. Thermopile may not be generating sufficient millivoltage.	<ol style="list-style-type: none"> 1. Be sure wire connections from thermopile at gas valve terminals are tight and thermopile is fully inserted into pilot bracket. 2. One of the wall switch wires may be grounded. Remove wall switch wires from valveterminals if pilot now stays lit, trace wall switch wiring for ground. May be grounded to fireplace or gas supply. 3. Check thermopile with millivolt meter. Take reading at thermopile terminals of gas valve. Should read 250-300 millivolts (minimum 150) while holding valve knob depressed in pilot position and wall switch “Off”. Replace faulty thermopile if reading is below specified minimum
	C. Plugged burner orifice.	Check burner orifices for debris and remove.
	D. Defective automatic valve operator.	Turn valve knob to “On”, place wall switch to “On” millivolt meter should read greater than 100 mV. If the reading is okay and the burner does not come on replace the gas valve.
4. Frequent pilot outage problem.	A. Pilot flame may be too low or blowing (high) causing the pilot safety to drop out.	Clean and/or adjust pilot flame for maximum flame impingement on thermopile and thermocouple.
	B. Possible blockage of the vent terminal.	Check the vent terminal for blockage (recycling the flue gases)

Troubleshooting the Gas Control System

Honeywell Millivolt Valve

WARNING: Before doing any gas control service work, remove glass front.

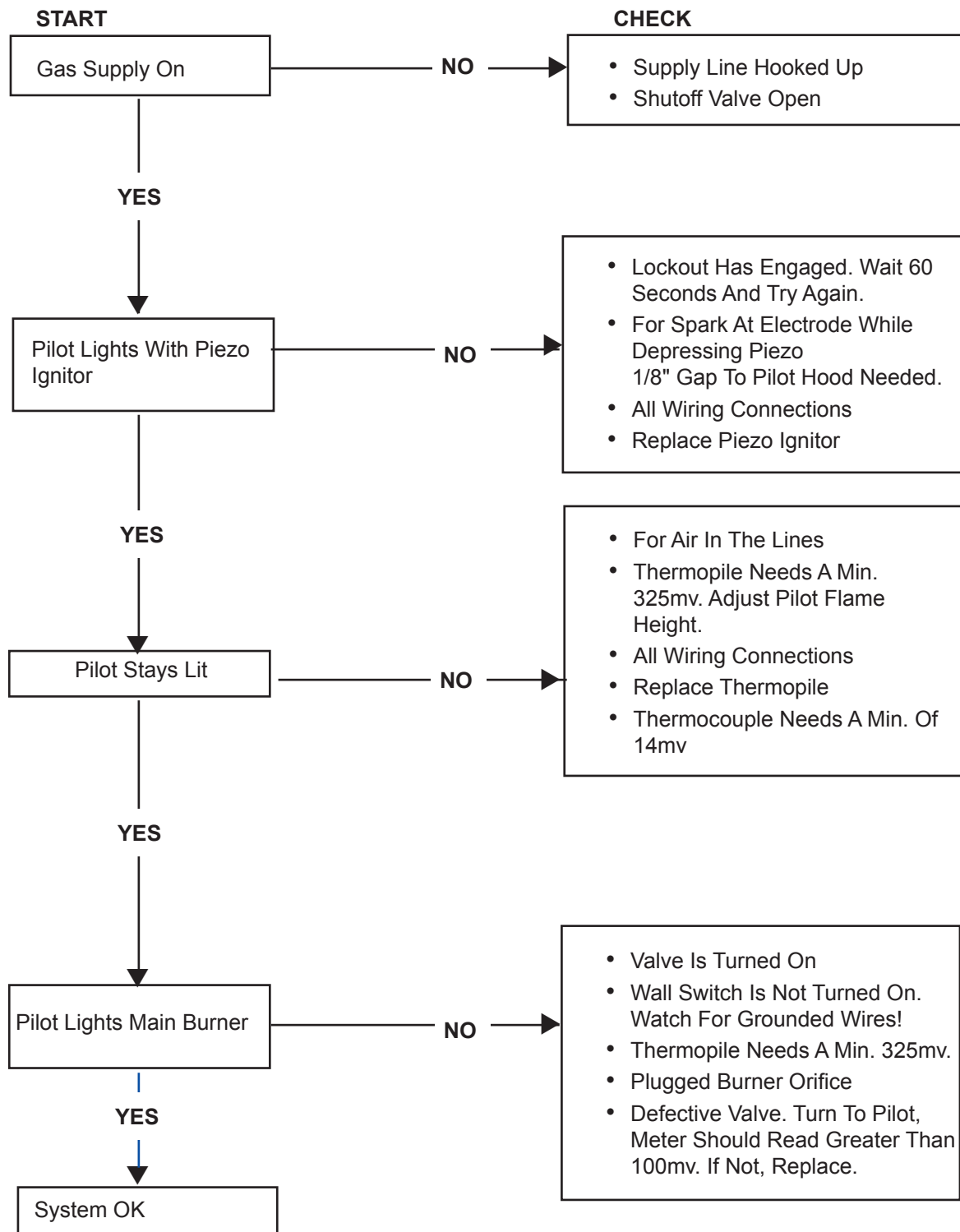

Fuel Conversion Instructions



The conversion of this appliance from one gas to another must be carried out by a qualified service technician.

1. Disconnect power to unit and shut off the gas supply.
2. Remove the glass (Refer to "Glass Removal" Section.)
3. Carefully remove the logs & lava rock material.
4. Remove the screws that are holding the burner housing in place.
5. Remove the burner housing. On this model you may need to loosen the pilot bracket retaining screw/nut and tilt pilot and bracket assembly to gain sufficient clearance to remove the burner housing.
6. Remove front and rear orifice and replace with orifice supplied in the conversion kit.

7. SIT top Convertible Pilot

Gently lift off pilot hood from the pilot. (Do not remove the spring clip holding the hood in place). Using a size 5/32" Allen key unscrew the exposed orifice. Insert the new orifice supplied in the kit, do not over tighten the orifice. Replace the pilot hood ensuring the index tab aligns with the notch on the hood.

PSE Pilot

Using a suitable wrench on hexagonal body unscrew the pilot hood assembly from the pilot, do not twist the hood itself. Remove the orifice and replace it with the new orifice supplied in the kit. Refit the pilot hood assembly. Do not over-tighten the pilot hood. The hood must return to its original alignment. Take care not to damage the thermocouple, thermopile or igniter.

8. SIT 820 NOVA Gas Control Valve (Fig. 11)

- a) Using a Torx T20 or slotted screwdriver, remove and save three pressure regulator mounting screws (A), pressure regulator tower (B) and diaphragm (C).
- b) Ensure the rubber gasket (D) is properly positioned and install the new HI/LO pressure regulator to valve using the new screws (E) supplied with the kit. Tighten screws securely. (Reference torque - 25 in.LB)
- c) Install the enclosed identification label (F) to the valve body where it can be easily seen.

Honeywell Gas Control Valve (Fig. 12)

The Honeywell valve fitted to this unit is suitable for use with LP or Natural Gas. It is converted to required gas application by the installation of a color coded "conversion screw".

- a. Using a suitable small screw-driver lift out the central regulator cap from the "HI/LO" knob on the valve.

- b. Unscrew the exposed conversion screw.
- c. Insert the new color coded conversion screw. Do not over-tighten the screw, it must be fingertight.
- d. Refit the regulator cap.
- e. Mount conversion label supplied with conversion screw to valve in a visible position.

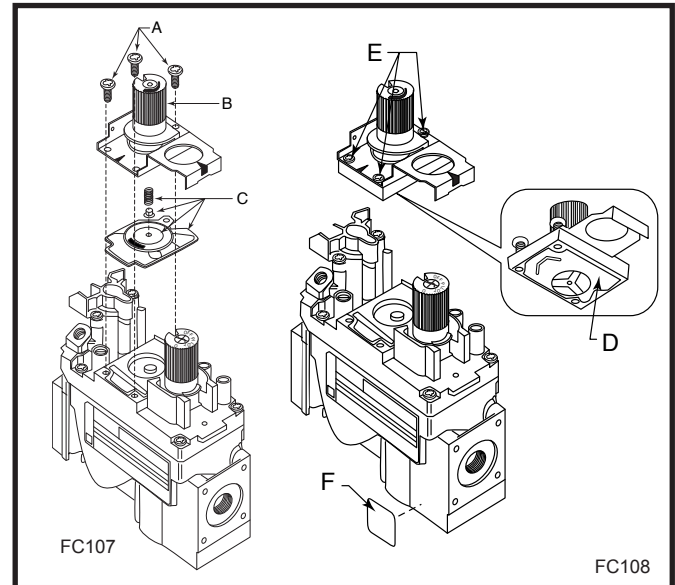

Fig. 45 NOVA SIT820 gas valve.

9. Reassemble fireplace in the reverse order, except for front glass. Leave this off until after unit has been checked for leaks and the gas supply has been bled.

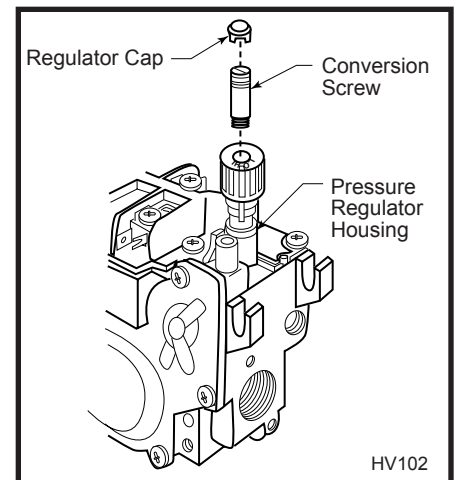

Fig. 46 Honeywell gas valve.

10. After bleeding gas line and checking for leaks with a soap solution, replace the front glass. Fire up the unit, check for flame impingement on logs, adjusting them if necessary. Check manifold and supply pressures. Make sure screws are tightened after checking pressure.



The procedure for converting from one gas to another is the same regardless of the initial gas used. The only variation is in the orifice sizes and component part numbers. Your authorized service provider will ensure correct parts are used.

Maintenance

Burner and Burner Compartment

It is important to keep the burner and the burner compartment clean. At least once per year the logs and lava rock/ember material should be removed and the burner compartment vacuumed and wiped out. Remove and replace the logs as per the instructions in this manual.



Always handle the logs with care as they are fragile and may also be hot if the fireplace has been in use.

FK24/FK12 Fan Assembly

The fan unit requires periodic cleaning. At least once per month in the operating season, open the lower louver panels and wipe or vacuum the area around the fan to remove any build up of dust or lint.

Brass Trim

Clean the brass trim pieces using a soft cloth lightly dampened with lemon oil. Do not use water or household cleaners on any brass components.

Contact your local representative to arrange an annual service program.

Cleaning the Standing Pilot Control System

The burner and control system consists of

- burner tube
- gas orifice
- pilot assembly
- thermopile
- millivolt gas valve

Most of these components may require only an occasional checkup and cleaning and some may require adjustment. **If repair is necessary, it should be performed by a qualified technician.**



Logs May Be HOT!!

1. Turn off pilot light at gas valve side.
2. Let fireplace cool if it has been running.
3. Remove window frame assembly. (Refer to Window Frame Assembly Removal section)
4. Remove logs.
5. Vacuum burner compartment especially around orifice primary air openings.
6. Visually inspect pilot. Brush or blow away any dust or lint accumulation.
7. Reinstall logs.
8. Ignite pilot - Refer to Lighting Instructions.
9. Reinstall window frame assembly.

To obtain proper operation, it is imperative that the pilot and burner's flame characteristics are steady, not lifting or floating.

Typically, the top 3/8" or 1/2" of the thermopile should be engulfed in the pilot flame. (Fig. 47)

To adjust pilot burner; (by qualified service technician)

1. Remove pilot adjustment cap.
2. Adjust pilot screw to provide properly sized flame.
3. Replace pilot adjustment cap.

The primary air shutter is set at factory and should only be adjusted, if necessary, by a qualified service technician.

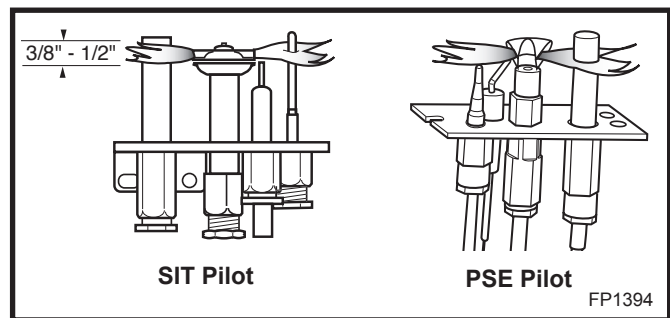
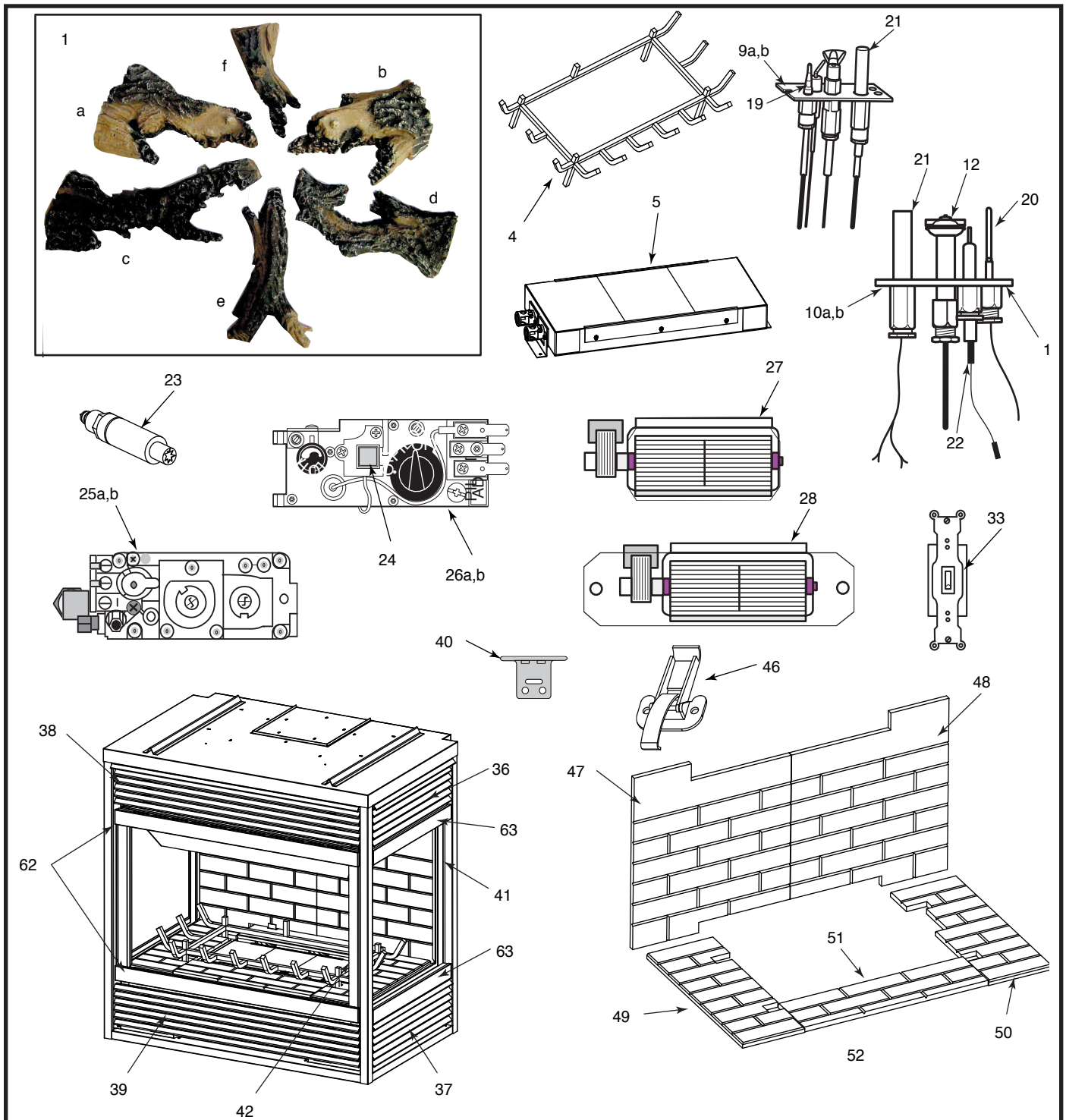

Fig. 47 Correct pilot flame appearance.



CFM Corporation reserves the right to make changes in design, materials, specifications, prices and discontinue colors and products at any time, without notice.

DVRTSB

Ref.	Description	DVRTSB
1.	Log Set (Complete)	10003855
1a.	Log - Rear Left	B105
1b.	Log - Rear Right	B106
1c.	Log - Front Left	B107
1d.	Log - Front Right	B108

DVRTSB (continued)

Ref.	Description	DVRTSB
1e.	Log - Front Center	B109
1f.	Log - Rear Center	B110
2.	Lava Rock Package (not shown)	10001454
3.	Ceramic Lava Rock Package (not shown)	57897
4.	Grate Assembly, Black	10003850
5.	Burner Housing Assembly w/Tiles	10003871
6.	Ceramic Tile (not shown)	10002165
7a.	Orifice, Rear Burner - Nat. (not shown)	Refer to the rating plate for specific orifice information
7b.	Orifice, Rear Burner - Prop. (not shown)	Refer to the rating plate for specific orifice information
8a.	Orifice, Front Burner - Nat. (not shown)	Refer to the rating plate for specific orifice information
8b.	Orifice, Front Burner - Prop. (not shown)	Refer to the rating plate for specific orifice information
9a.	Pilot Assembly PSE - Nat.	10001741
9b.	Pilot Assembly PSE - Prop.	10001742
10a.	Pilot Assembly SIT Top Convertible - Nat.	10002264
10b.	Pilot Assembly SIT Top convertible - Prop.	10002265
11.	Pilot SIT Top Convertible	10002266
12.	Pilot Hood, SIT Top Convertible	10002385
13.	Pilot Tube w/Fitting, PSE (not shown)	10003279
14.	Pilot Tube w/Fitting, SIT (not shown)	10001296
15a.	Orifice, Pilot PSE - Nat. (not shown)	10001822
15b.	Orifice, Pilot PSE - Prop. (not shown)	10001823
16a.	Orifice, Pilot Top Convertible - Nat. (not shown)	10002268
16b.	Orifice, Pilot Top Convertible - Prop. (not shown)	10002269
17.	Manifold Tube and Fittings (not shown)	10002492
18.	Flexible Gas Line (18") w/Fittings (not shown)	20002500
19.	Thermocouple, PSE	10001828
20.	Thermocouple, SIT Top Convertible	53373
21.	Thermopile	51827
22.	Ignitor Electrode (with Cable), SIT	10001297
23.	Ignitor (Piezo), SIT 820 Valve	52464
24.	Ignitor (Piezo), Honeywell Valve	20000062
25a.	Valve, SIT 820 - Nat.	52677
25b.	Valve, SIT 820 - Prop.	52678
26a.	Valve, Honeywell - Nat.	10001782
26b.	Valve, Honeywell - Prop.	10001759
27.	Fan & Bracket FK12 (Optional)	ZA1110
28.	Fan & Bracket FK24 (Optional)	54103
29.	Temperature Sensor (Optional) (not shown)	51704
30.	Fan Speed Control (Optional) (not shown)	51738
31.	Fan Speed Control Knob (Optional) (not shown)	51882
32.	Electrical Cord (not shown)	51865
33.	Remote ON/OFF Switch (RN/RP Models)	51842
34.	Wiring Harness (Remote Switch) (not shown)	55923
35.	Remote ON/OFF Switch Kit (Includes Bracket) (not shown)	53875
36.	Louvre Assembly, Side Top	10003867
37.	Louvre Assembly, Side Bottom	10003868
38.	Louvre Assembly, Front Top	10000037

DVRTSB (continued)

Ref.	Description	DVRTSB
39.	Louvre Assembly, Front Bottom	10003880
40.	Hinge, Lower Louvre Assembly	52356
41.	Window Frame Assembly Side	10003859
42.	Window Frame Assembly Front	10003843
43.	Window Glass (Complete with Gasket), Side (not shown)	10003860
44.	Window Glass (Complete with Gasket), Front (not shown)	55686
45.	Gasket Glass (not shown)	57317
46.	Window Frame Clamp	54174
47.	Refractory Lining (Rear Wall Left)	10003887
48.	Refractory Lining (Rear Wall Right)	10003888
49.	Refractory Lining (Floor Left)	10003890
50.	Refractory Lining (Floor Right)	10003891
51.	Refractory Lining (Floor Front)	10003892
52.	CR Floor Kit w/o Rear	10003889
53.	Air Inlet Cover Plate Assembly (not shown)	10002766
54.	Air Inlet Plate Gasket (not shown)	10002449
55.	Flue Pipe Plate Assembly (not shown)	10002509
56.	Flue Pipe Plate Gasket (not shown)	10002237
57.	Flue Cover Plate (not shown)	10002298
58.	Flue Cover Plate Gasket (not shown)	10002233
59.	Relief Plate (w/Gasket) (not shown)	10002543
60.	Deflector, Cabinet Top Front (not shown)	10002260
61.	Deflector, Cabinet Top Side (not shown)	10003869
62.	Trim Window Top/Bottom	54129-PB
63.	Trim Window Side	10003234

Optional Accessories

Fan Kits

FK24 Fan Assembly

This auxiliary fan system increases the efficiency of the circulation of the heating air.

The FK24 fan kit allows variable speed control of the circulation fan and also incorporates a heat sensor in the circuit.

Specifications

115 Volt / 60Hz / 56 Watts

Maintenance

The fan itself does not require regular maintenance, however periodic cleaning of the fan and the surrounding area is required.

Check the area under the control door (lower louvre assembly) and in front of the fan and wipe or vacuum this area at least once a month during the operating season.

Installation

The fan assembly and other components are supplied fully wired eliminating the need for a licensed electrician to carry out the installation.

If hard wiring the fan in using Method B (following) we strongly recommend the use of a licensed electrician.

1. Open the lower louvre assembly. Maneuver the fan & bracket assembly around the gas valve and lines to locate the unit onto the screw studs on the back of the fireplace.
2. Install the thermal sensor under the bottom of the of the firebox, locating it over the two 10mm studs and secure it with nuts.
3. Locate the fan speed control unit. This can be fitted behind the lower louvre assembly as in Figure 48 or located remotely in a conveniently located wall mounted electrical box. Remote location of the speed control will require suitable extension of the component wiring.
4. The power supply may be connected in two ways:

Method A

Route the 6' lead fitted to the unit to a conveniently located wall socket.

Method B

The EB-I receptacle box (Pt. # ZA1200) may be hard wired into the house supply. The fan lead is then plugged into the EB-I box.

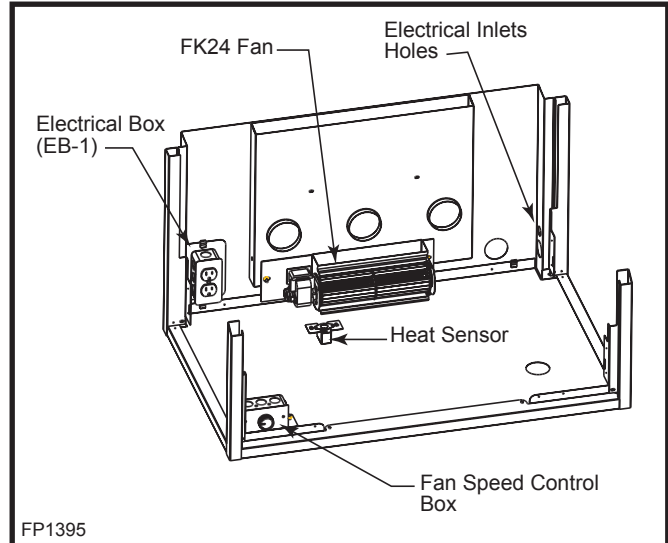

Fig. 48 FK24 fan location.

FK12

This auxiliary fan system increases the efficiency of the circulation of the heating air.

The FK12 Fan Assembly is a fixed speed fan system and does not allow for variable speed control. It does not use the speed control unit or the heat sensor used in the FK24 Kit.

Specifications

115 Volts / 60 Hz / 56 Watts.

Maintenance

The fan itself does not require regular maintenance, however periodic cleaning of the fan and the surrounding area is required.

Check the area under the control door (lower louvre assembly) and in front of the fan and wipe or vacuum this area at least once a month during the operating season.

Installation

The fan assembly is supplied fully wired eliminating the need for a licensed electrician to carry out the installation.

1. Open the lower Louvre assembly. Maneuver the fan & bracket assembly around the gas valve and lines to locate the unit against the back wall of the appliance, resting on the base.
2. With the protective cover removed from the self-adhesive 'Velcro' strips apply mild pressure to the fan & bracket unit to secure the strips to the metal panels. No further securing is required.
3. Power to the fan can be supplied by plugging the supplied lead into a conveniently located wall socket or by using a hard-wired EB-I connector box.



The fireplace, when installed, must be electrically connected and grounded in accordance with local codes or, in the absence of local codes, with the current CSA C22.1 Canadian Electric Code.



For USA installations follow the local codes and the national electrical code ANSI/NFPA No. 70.



Should this fan require servicing or repair the power supply must be disconnected. For rewiring of any replacement parts refer to Figure 49.



Any electrical re-wiring of this fan must be done by a licensed electrician.

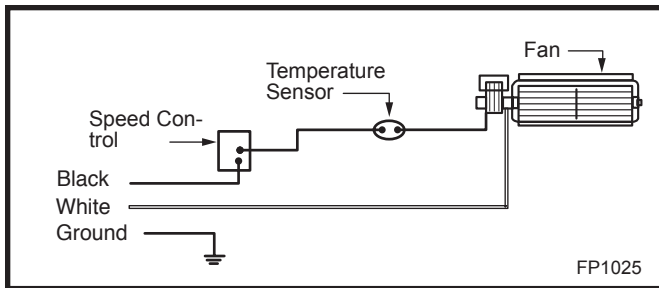

Fig. 49 FK24 fan wiring.

Remote Controls

Optional remote control units are available to control different functions of the appliance.

Model	Function/s Controlled
RC1	ON/OFF
RC2	ON/OFF and Temperature
IMTFK	Wall mounted thermostat control.

LIMITED LIFETIME WARRANTY

PRODUCT COVERED BY THIS WARRANTY

All Vermont Castings gas stoves, gas inserts, and gas fireplaces, and all Majestic brand gas fireplaces equipped with an Insta-Flame Ceramic Burner, or standard steel tube burner.

BASIC WARRANTY

The CFM Corporation Company (hereinafter referred to collectively as the Company) warrants that your new Vermont Castings or Majestic Gas Fireplace/Stove is free from manufacturing and material defects for a period of one year from the date of purchase, subject to the following conditions and limitations.

EXTENDED LIFETIME WARRANTY

The heat exchanger, where applicable, and combustion chamber of every Vermont Castings or Majestic gas product is warranted for life against through wall perforation. All appliances equipped with an Insta-Flame Ceramic Burner have limited lifetime coverage on the ceramic burner plaque. Warrantees are made to the original owner subject to proof of purchase and the conditions and limitations listed on this Warranty Document

COMPONENT WARRANTY

CAST IRON: All external and internal cast iron parts are warranted for a period of three years.

Note: On porcelain enamel finished external parts and accessories The Company offers no Warranty on chipping of enamel surfaces. Inspect all product prior to accepting it for any damage to the enamel.

The salt air environment of coastal areas or a high humidity environment can be corrosive to the porcelain enamel finish. These conditions can cause rusting of the cast iron beneath the porcelain enamel finish, which will cause the finish to flake off.

Dye lot variations with replacement parts and/or accessories can occur and are not covered by warranty.

GLASS DOORS: Glass doors are covered for a period of one year.

Glass doors are not warranted for breakage due to misuse or accident. Glass doors are not covered for discoloration or burned in stains due to environmental issues, or improper cleaning and maintenance.

BRASS PLATED PARTS AND ACCESSORIES: Brass parts should be cleaned with Lemon oil only. Brass cleaners cannot be used. Mortar mix and masonry cleaners may corrode the brass finish. The Company will not be responsible for, nor will it warrant any brass parts which are damaged by external chemicals or down draft conditions.

GAS VALVES: Gas valves are covered for a period of one year

ELECTRONIC AND MECHANICAL COMPONENTS: Electronic and mechanical components of the burner assembly are covered for one year. All steel tube burners are warranted for one year.

ACCESSORIES: Unless otherwise noted all components and CFM Corporation company supplied accessories are covered for a period of one year.

CONDITIONS AND LIMITATIONS

- This new Vermont Castings or Majestic product must be installed by a competent, authorized, service contractor. A licensed technician, as prescribed by the local jurisdiction must perform any installation/service work. It must be installed and operated at all times in accordance with the Installation and Operating instructions furnished with the product. Any alteration, willful abuse, accident, or misuse of the product shall nullify this warranty.
- This warranty is non-transferable, and is made to the original owner, provided that the purchase was made through an authorized supplier of the Company.
- The customer must pay for any Authorized Dealer in-home travel fees or service charges for in-home repair work. It is the dealers option whether the repair work will be done in the customer's home or in the dealer's shop.
- If upon inspection, the damage is found to be the fault of the manufacturer, repairs will be authorized at no charge to the customer parts and/or labor.

- Any part and/or component replaced under the provisions of this warranty is covered for six months or the remainder of the original warranty, whichever is longest.
- This warranty is limited to the repair of or replacement of part(s) found to be defective in material or workmanship, provided that such part(s) have been subjected to normal conditions of use and service, after said defect is confirmed by the Company's inspection.
- The company may, at its discretion, fully discharge all obligations with respect to this warranty by refunding the wholesale price of the defective part(s)
- Any installation, labor, construction, transportation, or other related costs/expenses arising from defective part(s), repair, replacement, or otherwise of same, will not be covered by this warranty, nor shall the Company assume responsibility for same. Further, the Company will not be responsible for any incidental, indirect, or consequential damages except as provided by law.
- SOME STATES DO NOT ALLOW FOR THE EXCLUSION OR LIMITATIONS OF INCIDENTAL AND CONSEQUENTIAL DAMAGES OR LIMITATIONS ON HOW LONG AN IMPLIED WARRANTY LASTS, SO THE ABOVE LIMITATIONS MAY NOT APPLY TO YOUR CIRCUMSTANCES. THIS WARRANTY GIVES YOU SPECIFIC RIGHTS AND YOU MAY HAVE OTHER RIGHTS WHICH VARY FROM STATE TO STATE.
- All other warranties-expressed or implied- with respect to the product, its components and accessories, or any obligations/liabilities on the part of the Company are hereby expressly excluded.
- The Company neither assumes, nor authorizes any third party to assume on its behalf, any other liabilities with respect to the sale of this Vermont Castings, Majestic product
- The warranties as outlined within this document do not apply to chimney components or other non Vermont Castings, Majestic accessories used in conjunction with the installation of this product..
- Damage to the unit while in transit is not covered by this warranty but is subject to claim against the common carrier. Contact the dealer from whom you purchased your fireplace/stove (do not operate the appliance as this might negate the ability to process the claim with the carrier).
- The Company will not be responsible for:
 - a) Down drafts or spillage caused by environmental conditions such as near-by trees, buildings, roof tops, hills, or mountains.
 - b) Inadequate ventilation or negative air pressure caused by mechanical systems such as furnaces, fans, clothes dryers, etc.
- This warranty is void if:
 - a) The fireplace has been operated in atmospheres contaminated by chlorine, fluorine, or other damaging chemicals.
 - b) The fireplace has been subjected to prolonged periods of dampness or condensation
 - c) Any damages to the fireplace, combustion chamber, heat exchanger or other components due to water, or weather damage, which is the result of but not limited to, improper chimney/venting installation.
 - d) Any alteration, willful abuse, accident, or misuse of the product has occurred.

IF WARRANTY SERVICE IS NEEDED...

- 1) Contact your supplier. Make sure you have your warranty, your sales receipt, and the model/serial number of your Vermont Castings, Majestic product.
- 2) DO NOT ATTEMPT TO DO ANY SERVICE WORK YOURSELF.

Canada

ENERGUIDE

**Look for the EnerGuide
Gas Fireplace Energy
Efficiency Rating in this brochure**

Based on CSA P.4.1-02

Efficiency Ratings				
Model	EnerGuide Ratings Fireplace Efficiency (%)	Steady State (%)		D.O.E. (AFUE%)
		Fan-OFF	Fan-ON	
DVRTSB RN	58.4	81	82	64
DVRTSB RP	58.4	82	83	64
DVRTSB RFN	58.4	81	82	64
DVRTSB RFP	58.4	82	83	64
DVRTSB EN	60.4	81	82	64
DVRTSB EP	60.4	82	83	64

**NATIONAL
FIREPLACE
INSTITUTE**



CERTIFIED

www.nficertified.org

We recommend that our gas hearth products be installed and serviced by professionals who are certified in the U.S. by the National Fireplace Institute® (NFI) as NFI Gas Specialists.

CFM Corporation

410 Admiral Blvd. • Mississauga, Ontario, Canada L5T 2N6
800-668-5323 • www.cfmcorp.com