

# **SERVICE MANUAL**

---

( KT-1748 / KT-1948 )



**Kortek Corporation**

## **1.PRECAUTIONS**

### **1-1 SAFETY PRECAUTIONS**

***WARNINGS : Service should not be attempted by anyone unfamiliar with the necessary precautions on this monitor. The following precautions are necessary during servicing.***

- 1) For continued safety, do not attempt to modify the circuit board.
- 2) Disconnect the AC Power before servicing.
- 3) When the Monitor is operating, do not touch any heat sink on the Chassis as it is self-heated.

#### **1-1-1 FIRE & SHOCK HARZARD**

- 1) During servicing, pay attention to the original wires whether it is uncoated or undressed, especially the wires in the high voltage circuit section. If there is any uncoated or melted wire is found, then please do not try to replace the related parts, and wait for the qualified service person's coming.
- 2) Many electrical, mechanical parts in this monitor have special safety-related characteristics for protection against shock hazard and others. These characteristics are often passed unnoticed by a visual inspection and the protection afforded by them cannot necessarily be obtained by using replacement components rated for higher voltage wattage,etc. Replacement parts which have these special characteristics are identified in the manual and supplements by shading on the schematic diagram and the parts list.
- 3) When replacing Chassis, always be certain that all the protective devices are installed properly.
- 4) leakage current check (figurel 1)

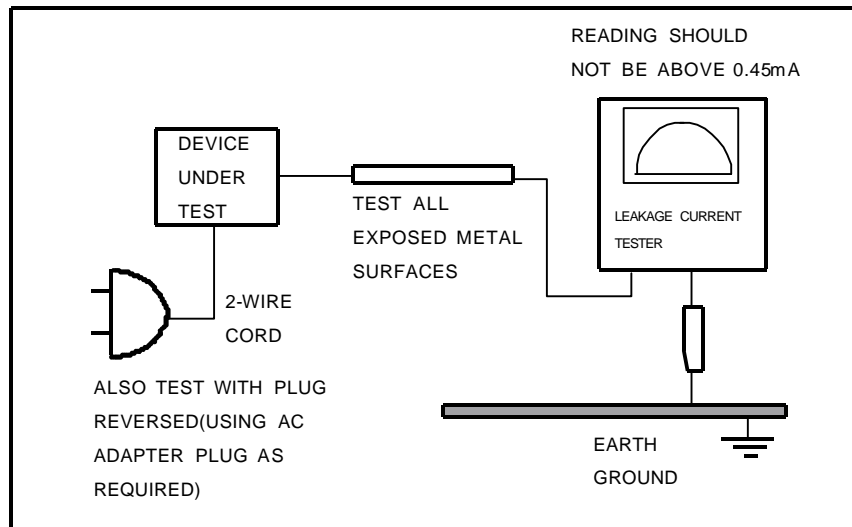

Figure 1

(TEST METHODE)

**1-1-2. X-RADIATION**

***WARNING : The only potential source of x-radiation is the picture tube, however when the high voltage. Circuitry is operating properly, there is no possibility of an x-radiation problem. The basic precaution is to keep the high voltage at the factory recommended level.***

- 1) To measure the high voltage, use a high-impedance high-voltage meter. Connect(-) to chassis and (+) to the CRT anode cap.
- 2) Turn the contrast control max. clockwise.
- 3) Measure the high voltage. The high voltage meter should indicate the following factory recommended level
- 4) If the actual level exceeds the max. factory set level, then immediate service is required to prevent the possibility of premature failure of components
- 5) To prevent X-RADIATION possibility, it is essential to use the specified picture tube.
- 6) The nominal high voltage is 24KV and not exceed 27KV at zero beam current at rated voltage.

**1-2. SERVICING PRECAUTION**

***WARNING 1 : First, reading "safety precaution" section of this manual. If unforeseen circumstances create conflict between the servicing precautions and safety precaution, always follow the safety precautions.***

***WARNING 2 : A high voltage VR replaced in the wrong direction may cause excessive X-RAY Emitting.***

***WARNING 3 : An electrolytic capacitor installed which the wrong polarity might explode.***

- 1) Servicing precautions are printed on the label, and should be followed closely.
- 2) Always unplug the AC power cord from the AC power source before attempting to remove or reinstall any component or assembly, disconnect PCB plugs or connectors, connect all test Components in parallel which an electrolytic capacitor.
- 3) After servicing, always check that the screw, components and wiring have been correctly reinstalled. Make sure that the area around the serviced part has not been damaged.
- 4) Check the insulation between the blades of the AC plug and accessible conductive parts(example : metal parts, input terminals)
- 5) Never touch any of the locked B+ voltage. Do not apply AC power to the unit(or any of its Assemblies) unless all solid-state heat sinks are correctly installed.
- 6) Always connect a test instrument's ground lead to the instrument chassis ground before connecting the positive lead; always remove the instrument's ground lead last.

**2. SOCKET PCB Circuit Description**

**1) VIDEO PRE AMP**

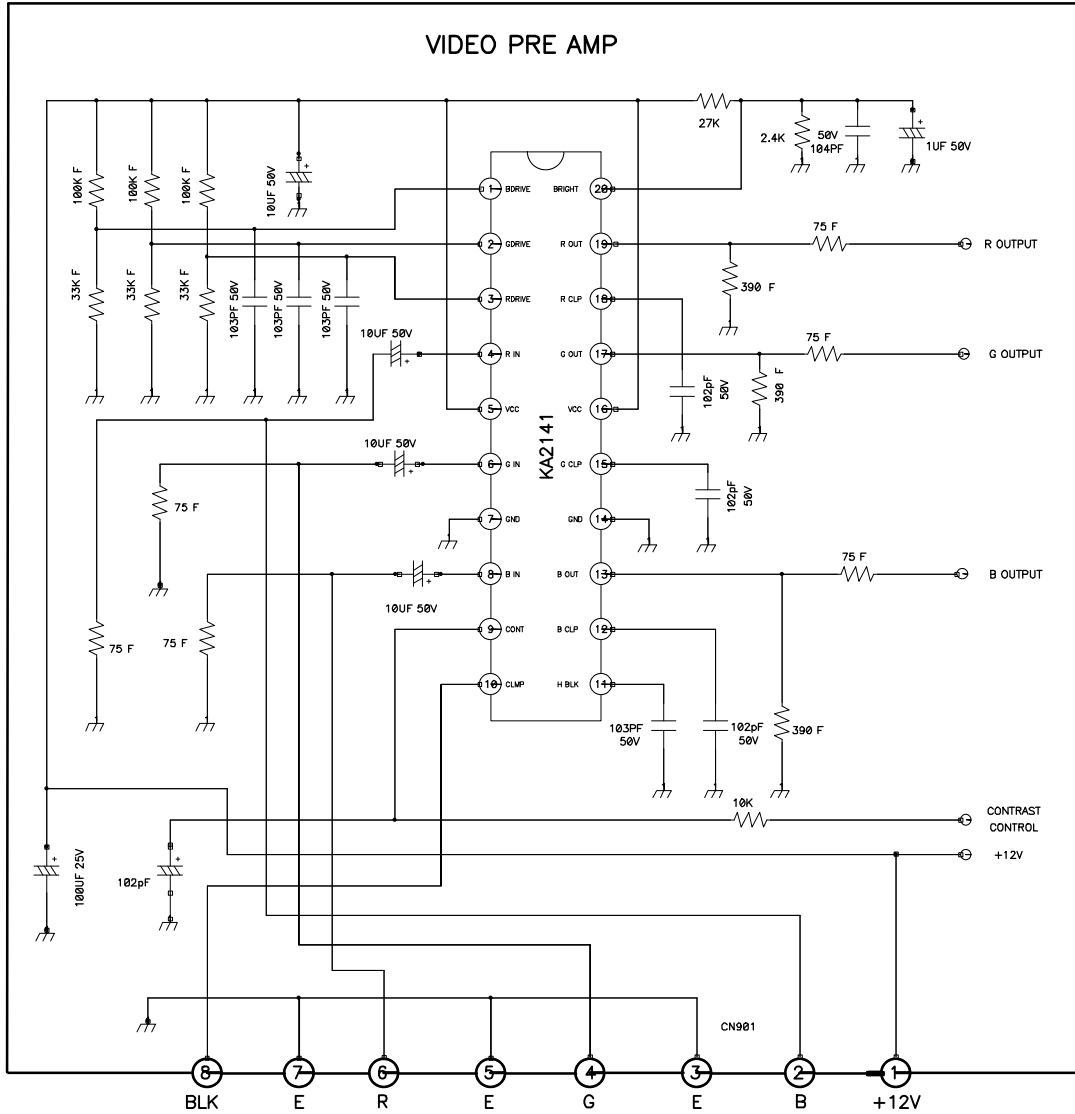

Video signal (0.7V PP) supplied from CN901 PIN2(BLUE), 4(GREEN), 6(RED) is supplied to IC901 PIN4, 6, 8 via C902, C903, C905.

IC901 performs VIDEO PRE AMP function, the amplitude is determined by DCBIAS of PIN 1, 2, 3, and OUT PUT VIDEO LEVEL is determined by PIN9(CONTRAST).

DCBIAS and contrast controlled VIDEO SIGNAL are output to PIN 19(RED) PIN 17(GREEN) PIN 13(BLUE) and supplied to VIDEO OUT PUT CIRCUIT.

For detailed information, please refer to KA2141 DATE BOOK.

2) VIDEO OUT PUT AMP

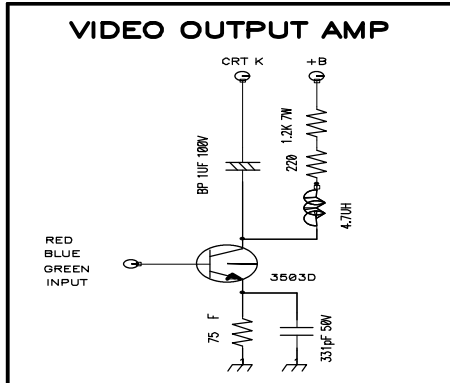

The SIGNAL supplied by VIDEO PRE AMP is input to the base of Q903.

The amplitude of Q903 is determined by EMITTER RESISTOR R938 and COLLECTOR RESISTOR R937 R945, and L903, C935 circuits are composed for frequency loss prevention and compensation. VIDEO OUT PUT AMP is composed of 3 circuits (R. G. B), the explanation above is about RED and since LOCATION NO. for the components are applied differently, please refer to complete circuit for GREEN and BLUE circuits.

For A/S or value changes for the components, please understand the characteristics of the components thoroughly and apply appropriately. R938 and R937 are for 1% (temperature compensation) and R945 is for 5% grade (temperature compensation for TR Q903) and NPO type capacitor must be used for C935.

3) G2 CONTROL CIRCUIT

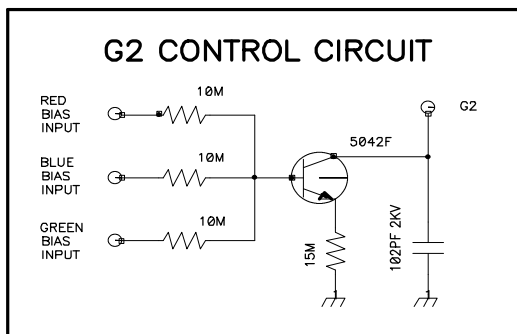

G2 CONTROL CIRCUIT is used to complement the movement of AUTO BIAS circuit and there is no need to adjust SCREEN voltage even when replacing CRT. The circuit works as follows. When R.G.B CATHODE voltage of CRT detected through R936, R931, R933 is applied to the base of Q904, Q904 automatically controls screen voltage and maintains the luminosity of the

screen evenly.

4)AUTO BIAS CIRCUIT

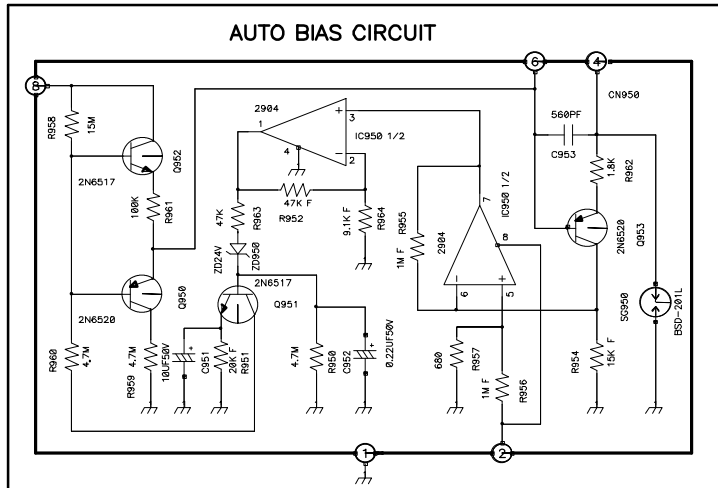

AUTO BIAS CIRCUIT is the circuit which detects the space between the cathode of CRT and GRID 1 and automatically adjusts BIAS voltage. It compensates the color changes when warming up and maintains evenly. Further, it extends the life - time by compensating the emission loss when CRT is used for long time and CRT can be replaced without additional adjustment when A/S. The description of circuits is as follows. PIN4 of SUB PCB is connected with the cathode of CRT. CRT CATHODE is composed of 3 electrodes (R, G, B) and GRID1 is also composed of 3 electrodes. The electrodes maintain spaces different from each other and BIAS voltage should supply voltages proportional to these spaces to acquire even color. Since the principle of the circuit operation is identical for R, G and B, RED circuit will be described as an example. CRT CATHODE emits hot electrons when the voltage is supplied to the heater of CRT and the temperature of the surface of adjacent CRT cathode reaches 900 and over. Then the hot electron moves toward CRT FACE though there are some differences according to the conditions of voltage applied to GRID1, GRID2, GRID3,5, and the current is produced toward opposite way, which shows up at CRT RED cathode.

SUB PCB PIN4 is connected with RED cathode, passes through R962 and the changes in current and voltage occurs at the emitter of Q953.

This changed current is displayed in the waveform and is sent to IC950 to amplify since it is very poor signal. IC950 amplifies in R956, R957, R955 ratio and sends the signal to PIN3 of IC950 for secondary amplification. The secondary amplification of IC950 is performed in R952, R964 ratio and the pulse is transformed into DC LEVEL by ZD950 and C952.

Transformed DC voltage controls Q951, Q952, Q950 and is sent to SUB PCB PIN6 to control the base of Q953. When the base voltage of Q953 changes, the voltage of emitter changes and controls the amount of hot electrons of CRT cathode.

The operation forms FEED BACK LOOP and maintains fixed value through repetition.

### 5) PULSE GENERATOR

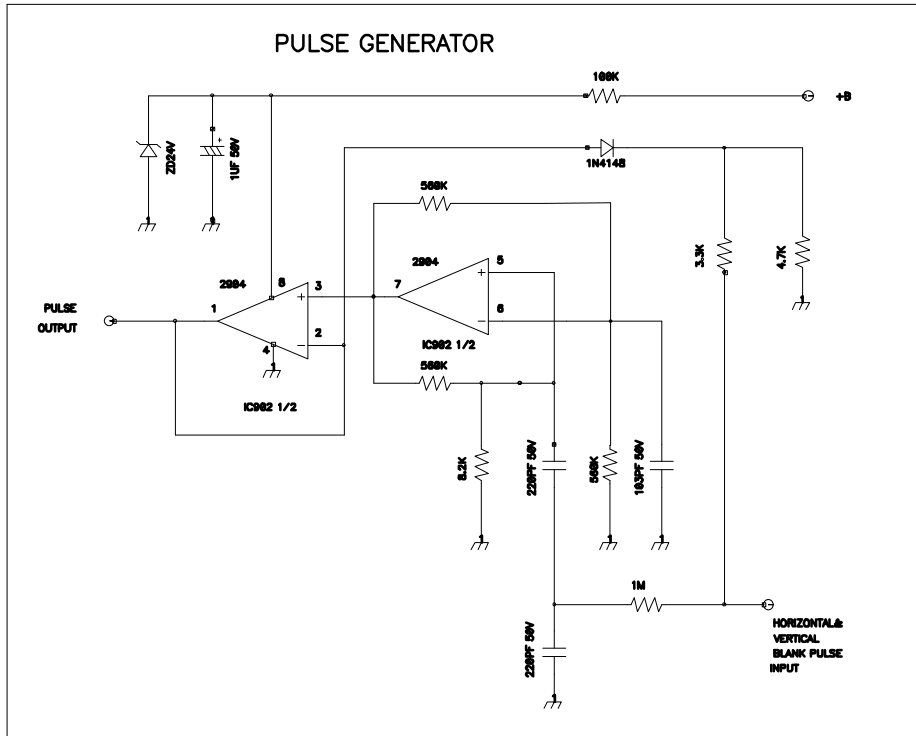

PULSE GENERATOR CIRCUIT supplies power to the control of AUTO BIAS circuit and produces and supplies pulse only while blanking period to prevent error. For more detailed TIMING CHART, please refer to the waveform of the circuit diagram.

The description of the circuit is as follows. HORIZONTAL & VERTICAL BLANK PULSE is supplied through R917, adjusts the waveform delay and width to ease AUTO BIAS movement at PULSE OSCILLATOR circuit composed of IC902, C920, R921, R923, R924, R922 and output to PIN 7 of IC902.

Since the output waveform can not have enough current the waveform is output to PIN1 after amplifying the current using OP AMP and supplies the current to AUTO BIAS CONTROL CIRCUIT.



**3. MAIN PCB Circuit Description**

**1) POWER SUPPLY**

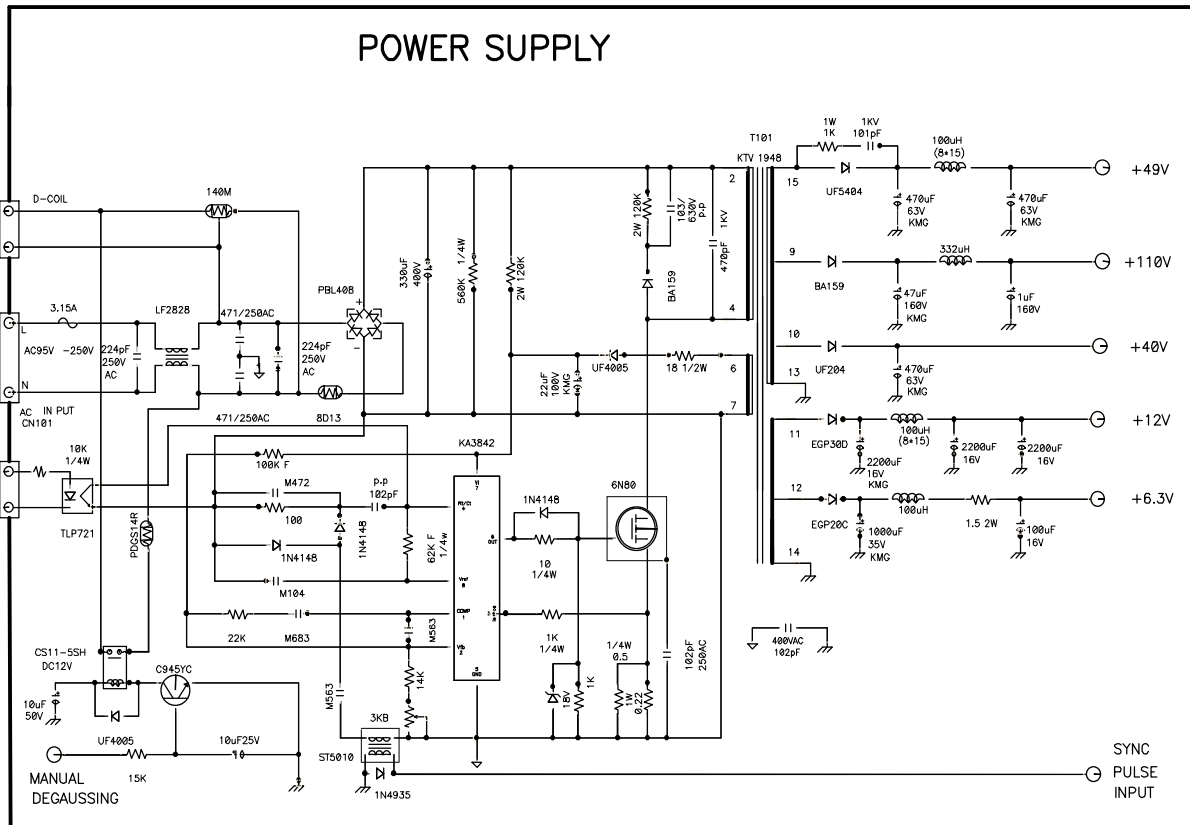

Power supply is composed of line filter, switching amp and switching trans circuit, line filter circuit eliminates the noise of the power line supplied from outside, prevents the noise occurred from switching amp from flowing out through outer power line, and the circuit is composed of C101, L101, C102, C103 and C104.

The AC power supplied through line filter is then supplied to D101 and transformed into ripple current and finally transformed into DC by C105.

The circuit of switching amp is composed of IC101, Q101 and peripheral circuits, IC101 oscillates and controls, and Q101 performs switching function.

IC101 starts oscillation by the transformed DC power supplies through R102 and outputs the pulse to PIN6.

IC101 PIN3, R106, R115 and R108 are composed to form OVER LODE prevention circuit, and IC101 PIN1,2 and the peripheral circuits of IC102 performs voltage adjustment and

stabilization function.

T102 is SYNC TRANS used to match the frequency of the monitor and power supply, and used to prevent noise on the screen when the distance between switching trans and deflection yoke is close.

Switching trans transforms the produced pulse to fit to the voltage of each part and supplies the pulse to these parts, DC voltage is supplied to PIN2 of T101, the pulse is produced at PIN4, and PIN6,7 is composed of a circuit which feeds back the changed amount of voltage and supplies VCC of IC101.

PIN15 is a circuit supplying horizontal deflected voltage through +49V LINE, and is composed of D120, C120, L110 and C121.

R120 and C131 are improved FCC and SMOKE NOISE circuits.

PIN9 of T101 is the circuit supplying voltage to VIDEO OUT PUT AMP through +110V line and the circuit is composed of D121, C123, L111 and C124.

PIN10 is the circuit supplying +B to VERTICAL OUT PUT AMP with +40V line and is composed of D122 and C125.

PIN11 is the circuit supplying activation voltage to HORIZONTAL & VERTICAL OSC IC with +12V line and is composed of D123, C126, L112, C127 and C132.

PIN12 is supplying voltage to CRT heater through +6.3V line and the circuit is composed of D124, C128, L113, R116 and C129. As other circuits for power supply, auto and manual degaussing circuits are composed of PH101 and RL101.

2) HORIZONTAL & VERTICAL MODE CONTROL CIRCUIT

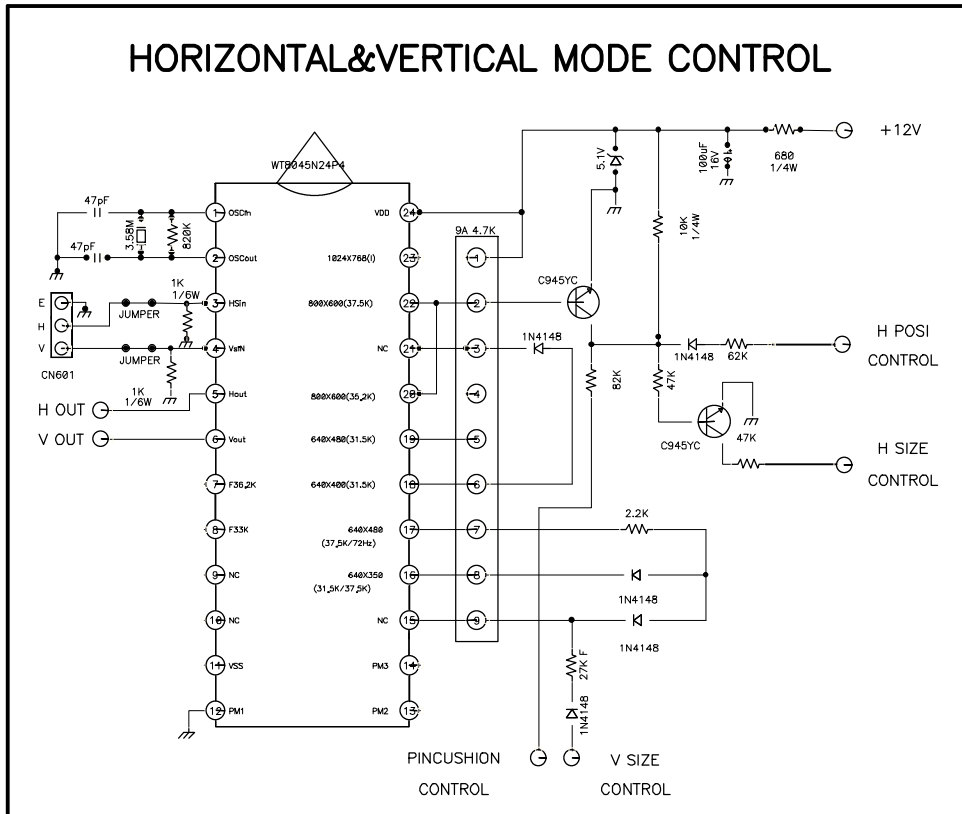

IC601 is in charge of horizontal & vertical sync and mode control, checks H.V SYNC input through PIN3,4 then output through PIN5,6, and regardless of input SYNC output SYNC is always output in negative value.

PIN1,2 forms oscillator circuit of IC601, and is composed of C601, C602, X601 and R603  
 PIN15 ~ PIN23 output low signal from corresponding mode after checking the status of input H.V SYNC.

Here, the output low signal and inverted high signal from Q603 control horizontal position, horizontal size, vertical size, pincushion, etc.

PIN24 uses +5V for the activation voltage of IC601, and ZD603 and R607 are in charge of this function.

AR601 performs pull-up resistor function for I PIN15 ~ PIN22 of C601 and supplies +5V to each gate.

3) CONTROL CIRCUIT

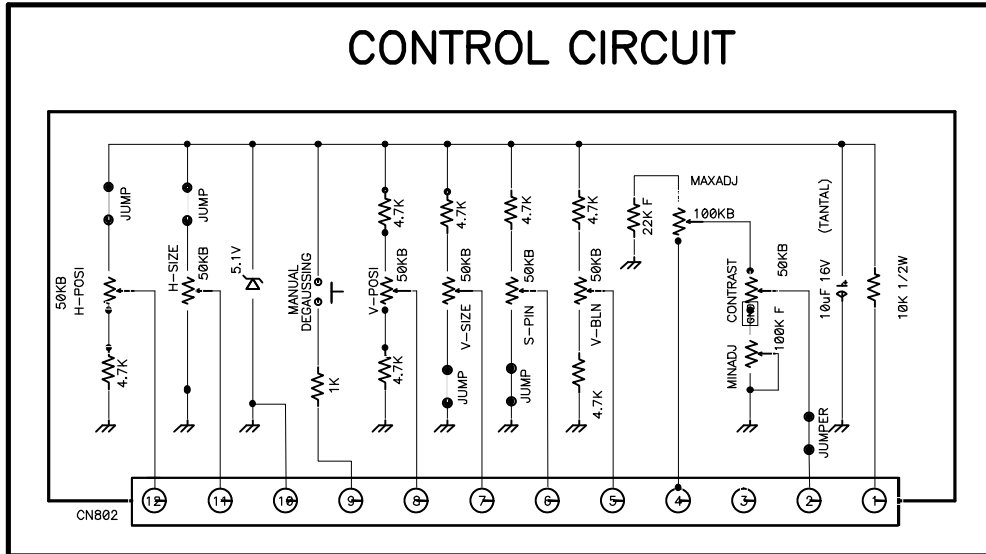

+40V is supplied to PIN1 of control circuit, and the voltage is transformed into +5V by R814, D801 and C801. +5V is controlled by V-BLN, S-PIN, V-SIZE, V-POSI H-SIZE, H-POSI And VR, output to PIN5,6,7,8,11,12 of CN801, adjusted by H-SIZE, H-POSI and VR, output to PIN5,6,7,8,11,12 of CN801 and controls IC301.

SW801 functions as manual degaussing switch and the output is to PIN9 of CN801 via R817.

VR801 is contrast control VR and outputs the voltage controlled into PIN2 of CN801.

VR810 is sub contrast VR, adjusts MAX value, and VR809 controls MIN value.

4) HORIZONTAL DRIVE CIRCUIT

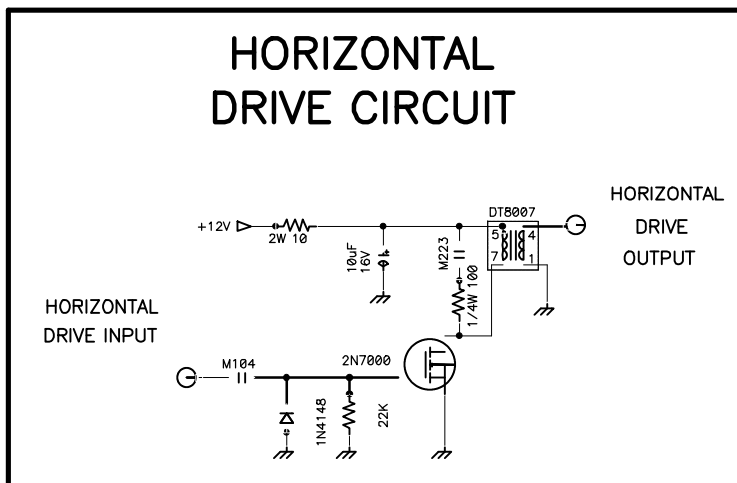

Horizontal drive pulse is applied to the gate of Q402 via C407 and D406 and R407 form BIAS

circuit. +12V is supplied to T402 and PIN7 of T402 generates pulse from switching Q402. The generated pulse is exposed to PIN4,1 of T402 and is supplied to horizontal output TR. R401 is resistor for current regulation and C417 performs noise filter function. C406 is the circuit for input current restraint and noise elimination.

### 5) HORIZONTAL & VERTICAL OSC

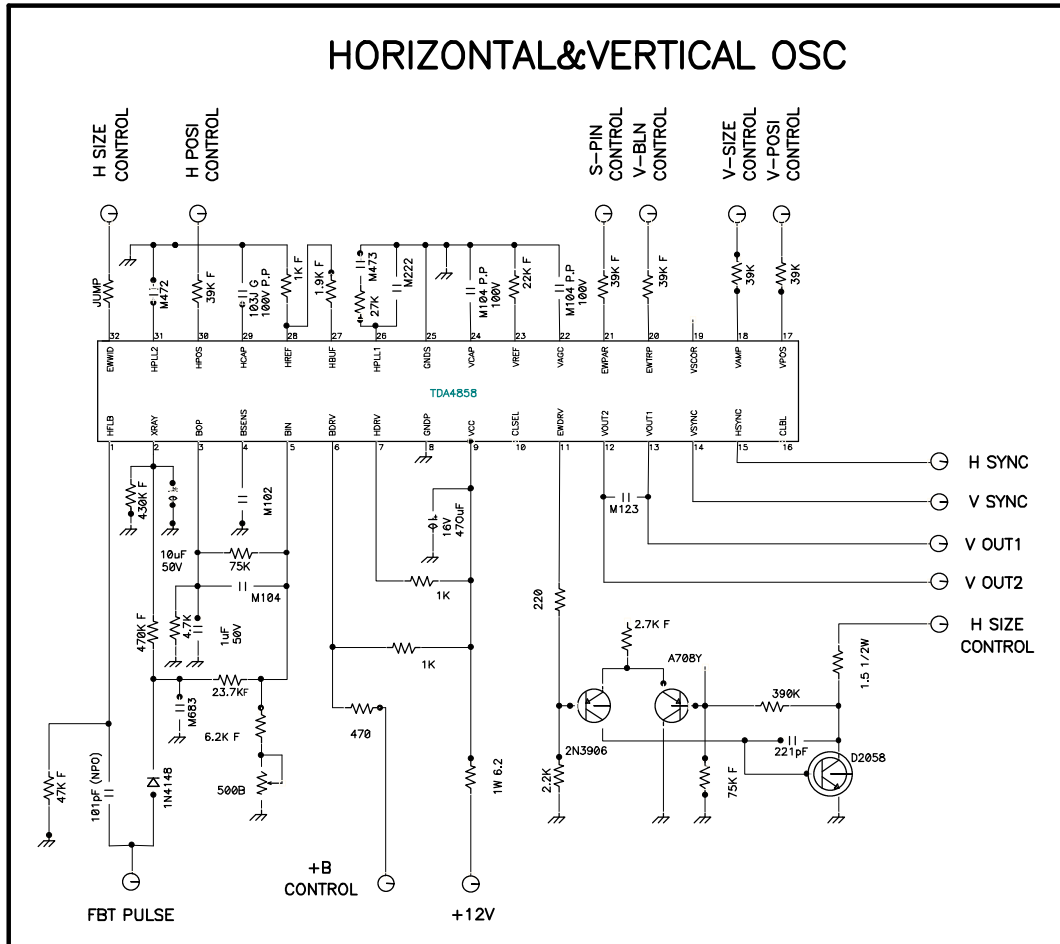

IC301 TDA4858 is in charge of horizontal & vertical OSC and drive, and is activated by +12V of PIN9. Vertical oscillator is composed of PIN22, 23, 24, C306, R306 and C305, PIN28 controls V-BLN, PIN18 V-SIZE and PIN17 V-POSI. Vertical drive output is performed by PIN12 and 13. PIN14 and PIN15 are V.H SYNC input terminals, and are always supplied in negative value. Horizontal oscillator is composed of PIN27, 28, 29, C302, R303 and R304. C303, R305 and C304 connected to PIN26 perform AFC function. PIN2 of IC301 performs X-RAY CONTROL function, and the circuit is composed of F.B.T PULSE, D301, C311, R313, R312 and C307. PIN5 and its peripheral circuits detect and compare F.B.T PULSE and output the pulse to PIN6 for constant high voltage at anytime. VR301 is high voltage control VR and



change DC voltage to Q411 and Q412 to move the horizontal raster to the left or right.

7) VERTICAL OUTPUT PUT CIRCUIT

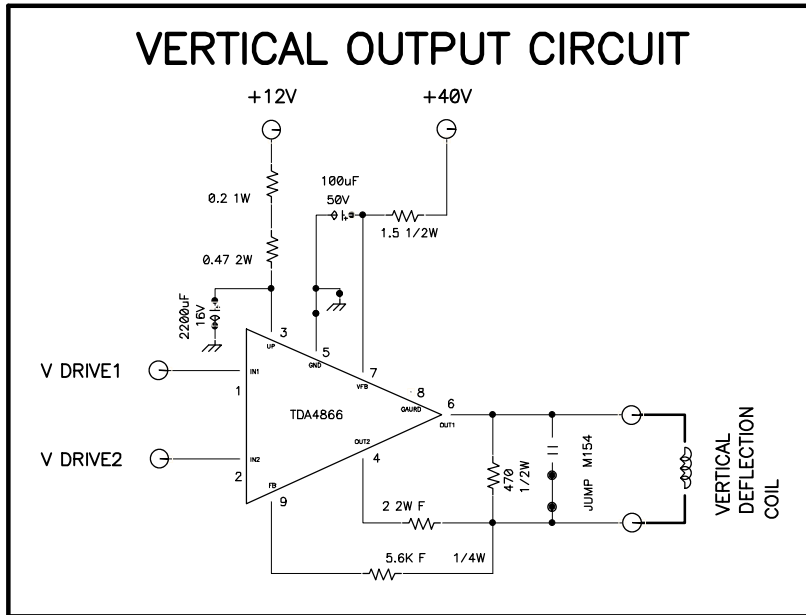

-IC302 TDA4866 is VERTICAL OUT OUTPUT CIRCUIT. It is the circuit which generates sawtooth wave form needed for deflection and supply to deflection yoke.

The waveform supplied to DRIVE 1, 2 is boosted and output to PIN6.

+12V is supplied to PIN3 of IC302 and +40V is supplied to PIN7.

R334 and R335 are 1%(F grade) FEED BACK resistors used for circuit accuracy and temperature compensation.

**4. SPECIFICATIONS**

Model : KT-1748

<b>PARAMETER</b>	<b>MIN</b>	<b>TYP</b>	<b>MAX</b>	<b>UNITS</b>
OPERATING VOLTAGE	90	115/230	260	VAC
OPERATING POWER		60	80	WATTS
LEAKAGE CURRENT TO CHASSIS GND. AT 250VAC, 50/60HZ (LINE/NEUT, IN COMMON)		< 0.40	0.45	mA
LEAKAGE CURRENT TO CHASSIS GND. AT 250VAC, 50/60HZ (LINE/NEUT, IN COMMON)		< 2.0	2.4	mA
OPERATING TEMPERATURE	10		60	
REL. HUMIDITY OPERATING	10		90	%
IMPLOSION PROTECTION	PROVIDEO BY BAND AND MOUNTING LUGS			
MAGNETIC SHIELD	INTERNAL			
DEGAUSSING	MANUAL / AUTO			
VIDEO SIGNAL	+ 0.7Vpp, 75 OHM-MONITOR TERMINATIONS			
RASTER DIM, ADJUST RANGE VERTICAL	< 200		> 245	mm
RASTER DIM, ADJUST RANGE HORIZONTAL	< 280		> 330	mm
MODE	640 480 / 800 600 / 1024 * 768			
PINCUSHION			3.0	%
MIS-CONVERGENCE CENTER		0.25	0.3	mm
CORNERS		0.35	0.45	mm
*VERTICAL				
SCAN RATE	45		90	HZ
HOLD IN RANGE			± 5	HZ
HIGH LEVEL	3.0	5.0	5.5	VOLT
LOW LEVEL	0.0	0.0	1	VOLT
NON-LINEARITY			5	%
*HORIZONTAL				
SCAN FREQ	31		48	KHZ
HOLD IN RANGE			± 500	HZ
SYNC. POLARITY	POSITIVE			
HIGH LEVEL	3.0	5.0	5.5	VOLT
LOW LEVEL	0.0	0.0	1	VOLT
NON-LINEARITY			5	%
WHITE BALANCE	X= 281 ± 0.020 y= 311 ± 0.020			
LUMINANCE	ADJUSTABLE WITH USER CONTROL 10 ± 3(F/L) ~ 55 ± 5(F/L)			



Model : KT-1948

<b>PARAMETER</b>	<b>MIN</b>	<b>TYP</b>	<b>MAX</b>	<b>UNITS</b>
OPERATING VOLTAGE	90	115/230	260	VAC
OPERATING POWER		85	90	WATTS
LEAKAGE CURRENT TO CHASSIS GND. AT 250VAC, 50/60HZ (LINE/NEUT, IN COMMON)		< 0.40	0.45	mA
LEAKAGE CURRENT TO CHASSIS GND. AT 250VAC, 50/60HZ (LINE/NEUT, IN COMMON)		< 2.0	2.4	mA
OPERATING TEMPERATURE	10		60	
REL. HUMIDITY OPERATING	10		90	%
IMPLOSION PROTECTION	PROVIDEO BY BAND AND MOUNTING LUGS			
MAGNETIC SHIELD	INTERNAL			
DEGAUSSING	MANUAL / AUTO			
VIDEO SIGNAL	+ 0.7Vpp, 75 OHM-MONITOR TERMINATIONS			
RASTER DIM, ADJUST RANGE VERTICAL	< 235		> 330	mm
RASTER DIM, ADJUST RANGE HORIZONTAL	< 323		> 395	mm
MODE	640 480 / 800 600 / 1024 * 768			
PINCUSHION			3.0	%
MIS-CONVERGENCE CENTER		0.25	0.3	mm
CORNERS		0.35	0.45	mm
*VERTICAL				
SCAN RATE	45		90	HZ
HOLD IN RANGE			± 5	HZ
HIGH LEVEL	3.0	5.0	5.5	VOLT
LOW LEVEL	0.0	0.0	1	VOLT
NON-LINEARITY			5	%
*HORIZONTAL				
SCAN FREQ	31		48	KHZ
HOLD IN RANGE			± 500	HZ
SYNC. POLARITY	POSITIVE			
HIGH LEVEL	3.0	5.0	5.5	VOLT
LOW LEVEL	0.0	0.0	1	VOLT
NON-LINEARITY			5	%
WHITE BALANCE	X= 281 ± 0.020 y= 311 ± 0.020			
LUMINANCE	ADJUSTABLE WITH USER CONTROL 10 ± 3(F/L) ~ 55 ± 5(F/L)			

5. TROUBLE SHOOTING GUIDE

TROUBLESHOOTING CHARTS

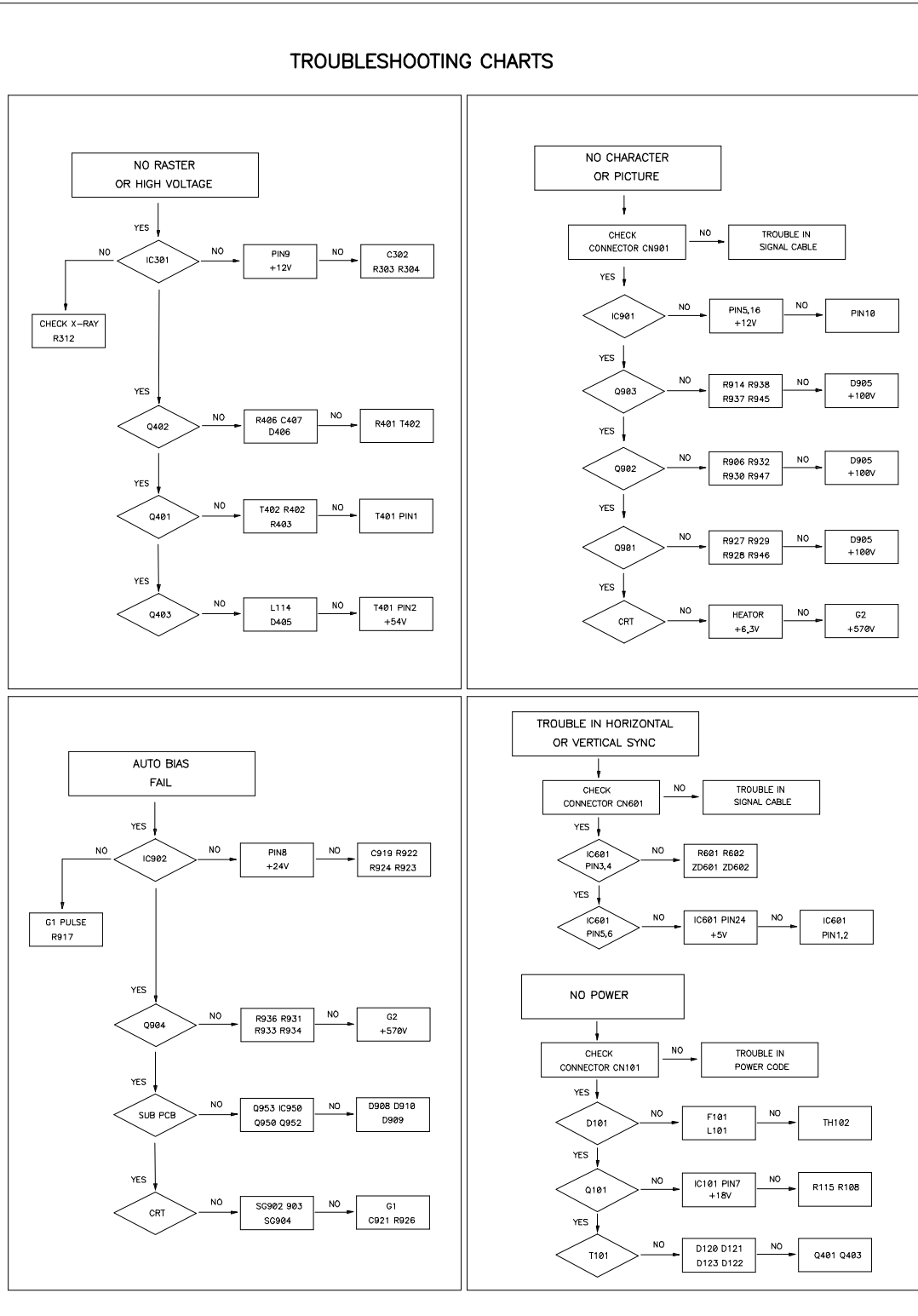

6. BLOCK DIAGRAM

**KT-XX48**

