



KRAMER ELECTRONICS LTD.

USER MANUAL

MODEL:

VS-211H
Automatic HDMI Standby
Switcher

P/N: 2900-000681 Rev 5



VS-211H Quick Start Guide

This guide helps you install and use your product for the first time. For more detailed information, go to http://www.kramerelectronics.com/support/product_downloads.asp to download the latest manual or scan the QR code on the left.

Step 1: Check what's in the box

- VS-211H Automatic HDMI Standby Switcher
- 1 Power supply (5V DC)
- 1 Quick Start sheet
- 4 Rubber feet

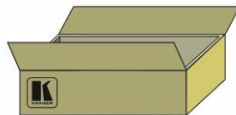

Save the original box and packaging in case your VS-211H needs to be returned to the factory for service.

Step 2: Install the VS-211H

Attach the rubber feet and place on a table or mount the machine in a rack (using an optional RK-3T rack mount).

Step 3: Connect the inputs and outputs

Always switch off the power on each device before connecting it to your VS-211H.

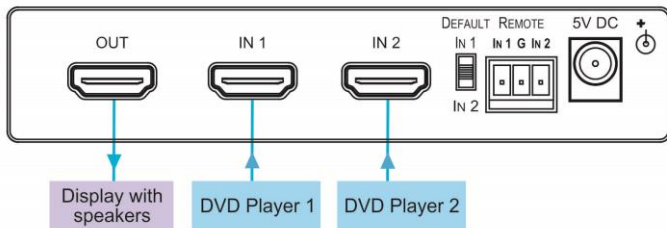

Always use Kramer high-performance cables for connecting AV equipment to the VS-211H.

Step 4: Connect the power

Connect the 5V DC power adapter to the VS-211H and plug the adapter into the mains electricity.



Step 5: Operate the VS-211H

Set the default input using the DEFAULT IN switch. Control via the REMOTE terminal block:

To activate INPUT 1, attach PIN IN 1 to PIN G



To activate INPUT 2, attach PIN IN 2 to PIN G



Contents

1	Introduction	1
2	Getting Started	2
2.1	Achieving the Best Performance	2
2.2	Safety Instructions	3
2.3	Recycling Kramer Products	3
3	Overview	4
3.1	Defining the VS-211H Automatic HDMI Standby Switcher	5
4	Using the VS-211H	6
4.1	Connecting the VS-211H	6
4.2	Selecting the Default Master Source Signal	7
4.3	Connecting the REMOTE Terminal Block Connector	8
5	Technical Specifications	9

Figures

Figure 1:	VS-211H Automatic HDMI Standby Switcher	5
Figure 2:	VS-211H Connections	7
Figure 3:	REMOTE Terminal Block Connector	8

1 Introduction

Welcome to Kramer Electronics! Since 1981, Kramer Electronics has been providing a world of unique, creative, and affordable solutions to the vast range of problems that confront the video, audio, presentation, and broadcasting professional on a daily basis. In recent years, we have redesigned and upgraded most of our line, making the best even better!

Our 1,000-plus different models now appear in 11 groups that are clearly defined by function: GROUP 1: Distribution Amplifiers; GROUP 2: Switchers and Routers; GROUP 3: Control Systems; GROUP 4: Format/Standards Converters; GROUP 5: Range Extenders and Repeaters; GROUP 6: Specialty AV Products; GROUP 7: Scan Converters and Scalers; GROUP 8: Cables and Connectors; GROUP 9: Room Connectivity; GROUP 10: Accessories and Rack Adapters and GROUP 11: Sierra Products.

Congratulations on purchasing your Kramer **VS-211H** *Automatic HDMI Standby Switcher*, which is ideal for providing backup switching for broadcast and post-production applications.

2 Getting Started

We recommend that you:

- Unpack the equipment carefully and save the original box and packaging materials for possible future shipment
- Review the contents of this user manual



Go to <http://www.kramerelectronics.com> to check for up-to-date user manuals, application programs, and to check if firmware upgrades are available (where appropriate).

2.1 Achieving the Best Performance

To achieve the best performance:

- Use only good quality connection cables (we recommend Kramer high-performance, high-resolution cables) to avoid interference, deterioration in signal quality due to poor matching, and elevated noise levels (often associated with low quality cables)
- Do not secure the cables in tight bundles or roll the slack into tight coils
- Avoid interference from neighboring electrical appliances that may adversely influence signal quality
- Position your Kramer **VS-211H** away from moisture, excessive sunlight and dust



This equipment is to be used only inside a building. It may only be connected to other equipment that is installed inside a building.

2.2 Safety Instructions



Caution: There are no operator serviceable parts inside the unit

Warning: Use only the Kramer Electronics input power wall adapter that is provided with the unit

Warning: Disconnect the power and unplug the unit from the wall before installing

2.3 Recycling Kramer Products

The Waste Electrical and Electronic Equipment (WEEE) Directive 2002/96/EC aims to reduce the amount of WEEE sent for disposal to landfill or incineration by requiring it to be collected and recycled. To comply with the WEEE Directive, Kramer Electronics has made arrangements with the European Advanced Recycling Network (EARN) and will cover any costs of treatment, recycling and recovery of waste Kramer Electronics branded equipment on arrival at the EARN facility. For details of Kramer's recycling arrangements in your particular country go to our recycling pages at <http://www.kramerelectronics.com/support/recycling/>.

3 Overview

The **VS-211H** is a high-performance automatic standby switcher for HDMI video signals. The **VS-211H** automatically switches to the secondary input whenever the primary video signal is interrupted. If the primary signal reappears, the unit automatically switches back to the primary input.

In addition, the **VS-211H** features:

- A maximum data rate of up to 2.25Gbps
- HDTV compatibility
- HDCP and HDMI compliance
- 3D pass through
- EDID PassThru that passes EDID signals from source to display
- A DEFAULT INPUT switch for selecting the default HDMI master source signal
- Contact closure remote control for forced operation
- Active switching

3.1 Defining the VS-211H Automatic HDMI Standby Switcher

This section defines the **VS-211H**.

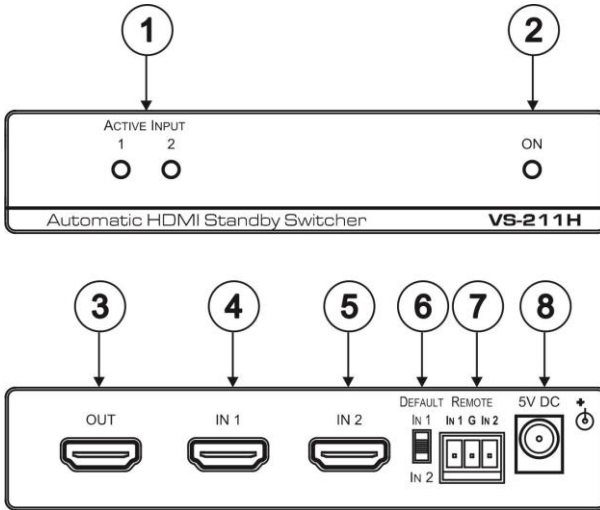

Figure 1: VS-211H Automatic HDMI Standby Switcher

#	Feature	Function
1	ACTIVE INPUT 1,2 LEDs	Illuminate when input is active
2	ON LED	Illuminates when receiving power
3	OUT HDMI Connector	Connects to the HDMI output acceptor
4	IN 1 HDMI Connector	Connects to the HDMI input source 1
5	IN 2 HDMI Connector	Connects to the HDMI input source 2
6	DEFAULT INPUT Switch	Switches to select the default input (IN 1 or IN 2)
7	REMOTE IN 1 and IN 2 Terminal Block Connectors	Connect to a contact closure switch
8	5V DC	+5V DC connector for powering the unit

4 Using the VS-211H

This section describes how to:

- Connect the **VS-211H** (see [Section 4.1](#))
- Select the default master source signal (see [Section 4.2](#))
- Connect the REMOTE connector (see [Section 4.3](#))

4.1 Connecting the VS-211H



Always switch off the power to each device before connecting it to your **VS-211H**. After connecting your **VS-211H**, connect its power and then switch on the power to each device.

To connect the **VS-211H**, as illustrated in the example in [Figure 2](#), do the following:

1. Connect the IN 1 HDMI connector to the HDMI input source 1 (for example, DVD player 1).
2. Connect HDMI input source 2 (for example, DVD player 2) to the IN 2 HDMI connector.
3. Connect HDMI acceptor (for example, an LCD display) to the OUT HDMI connector.
4. Set the DEFAULT INPUT switch to whichever input is the master input, as described in [Section 4.2](#).
5. If needed, connect the remote switches to the REMOTE IN 1 and IN 2 terminal block connectors, as described in [Section 4.3](#).
6. Connect the 5V DC power adapter to the power socket and connect the adapter to the mains electricity.

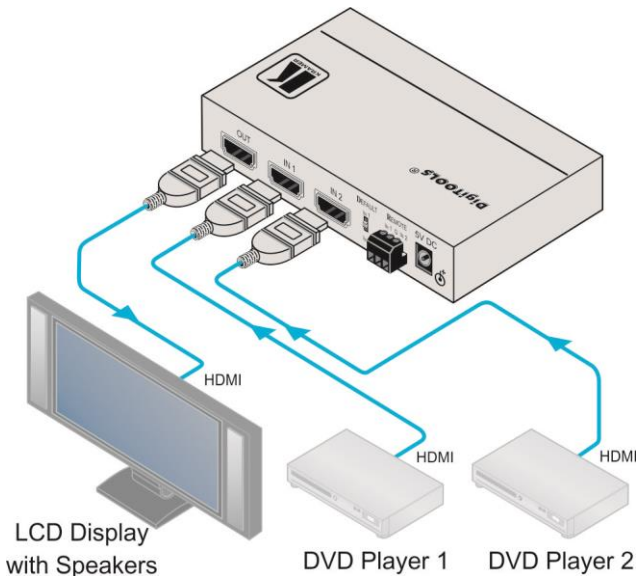

Figure 2: VS-211H Connections

4.2 Selecting the Default Master Source Signal

When active input sources are connected to IN 1 and IN 2, the DEFAULT INPUT switch setting determines the default master input source.

If the master input signal is not detected, the **VS-211H** automatically activates the standby input:

- If IN 1 is the default input and it fails, IN 2 activates
- If IN 2 is the default input and it fails, IN 1 activates

If the master input reactivates while the standby input is active, the unit automatically switches back to the master input:

- If IN 2 is active while IN 1 is the default input, when IN 1 reactivates, it is switched to the output
- If IN 1 is active while IN 2 is the default input, when IN 2 reactivates, it is switched to the output

4.3 Connecting the REMOTE Terminal Block Connector

Regardless of the default input switch setting, you can force the switching of the active input by remote control. To do this, connect the appropriate REMOTE input terminal block connector pins to a contact closure switch (see [Figure 3](#)).

Note that the connection should be permanent, since the VS-211H reverts to an automatic switcher when the connection is removed.

- To force IN 1: connect REMOTE IN1 to PIN G (ground)
- To force IN 2: connect REMOTE IN2 to PIN G (ground)



Do not connect both the REMOTE IN1 and the REMOTE IN2 to PIN G simultaneously

Attach PIN IN1 to
PIN G to activate
INPUT 1

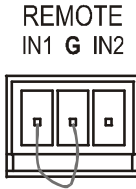

Attach PIN IN2 to
PIN G to activate
INPUT 2



Figure 3: REMOTE Terminal Block Connector

Note: The contact closure setting remains in effect until an event occurs such as changing the default input switch or connecting or attaching an HDMI device.

5 Technical Specifications

INPUTS:	2 HDMI on HDMI connectors
OUTPUT:	1 HDMI on an HDMI connector
DATA RATE:	Supports 2.25Gbps per graphic channel
STANDARDS COMPLIANCE:	HDCP and HDMI
CONTROLS:	Contact closure remote control, input default selection switch
POWER CONSUMPTION:	5V DC, 550mA
OPERATING TEMPERATURE:	0° to +40°C (32° to 104°F)
STORAGE TEMPERATURE:	-40° to +70°C (-40° to 158°F)
HUMIDITY:	10% to 90%, RHL non-condensing
DIMENSIONS:	12cm x 7.2cm x 2.4cm (4.7" x 2.8" x 1.0") W, D, H
WEIGHT:	0.3kg (0.7lbs)
ACCESSORIES:	Power supply, mounting bracket
OPTIONS:	RK-3T 19" rack adapter
Specifications are subject to change without notice at http://www.kramerelectronics.com	

LIMITED WARRANTY

The warranty obligations of Kramer Electronics for this product are limited to the terms set forth below:

What is Covered

This limited warranty covers defects in materials and workmanship in this product.

What is Not Covered

This limited warranty does not cover any damage, deterioration or malfunction resulting from any alteration, modification, improper or unreasonable use or maintenance, misuse, abuse, accident, neglect, exposure to excess moisture, fire, improper packing and shipping (such claims must be presented to the carrier), lightning, power surges, or other acts of nature. This limited warranty does not cover any damage, deterioration or malfunction resulting from the installation or removal of this product from any installation, any unauthorized tampering with this product, any repairs attempted by anyone unauthorized by Kramer Electronics to make such repairs, or any other cause which does not relate directly to a defect in materials and/or workmanship of this product. This limited warranty does not cover cartons, equipment enclosures, cables or accessories used in conjunction with this product.

Without limiting any other exclusion herein, Kramer Electronics does not warrant that the product covered hereby, including, without limitation, the technology and/or integrated circuit(s) included in the product, will not become obsolete or that such items are or will remain compatible with any other product or technology with which the product may be used.

How Long Does this Coverage Last

Seven years as of this printing; please check our Web site for the most current and accurate warranty information.

Who is Covered

Only the original purchaser of this product is covered under this limited warranty. This limited warranty is not transferable to subsequent purchasers or owners of this product.

What Kramer Electronics will do

Kramer Electronics will, at its sole option, provide one of the following three remedies to whatever extent it shall deem necessary to satisfy a proper claim under this limited warranty:

1. Elect to repair or facilitate the repair of any defective parts within a reasonable period of time, free of any charge for the necessary parts and labor to complete the repair and restore this product to its proper operating condition. Kramer Electronics will also pay the shipping costs necessary to return this product once the repair is complete.
2. Replace this product with a direct replacement or with a similar product deemed by Kramer Electronics to perform substantially the same function as the original product.
3. Issue a refund of the original purchase price less depreciation to be determined based on the age of the product at the time remedy is sought under this limited warranty.

What Kramer Electronics will not do Under This Limited Warranty

If this product is returned to Kramer Electronics or the authorized dealer from which it was purchased or any other party authorized to repair Kramer Electronics products, this product must be insured during shipment, with the insurance and shipping charges prepaid by you. If this product is returned uninsured, you assume all risks of loss or damage during shipment. Kramer Electronics will not be responsible for any costs related to the removal or re-installation of this product from or into any installation. Kramer Electronics will not be responsible for any costs related to any setting up this product, any adjustment of user controls or any programming required for a specific installation of this product.

How to Obtain a Remedy under this Limited Warranty

To obtain a remedy under this limited warranty, you must contact either the authorized Kramer Electronics reseller from whom you purchased this product or the Kramer Electronics office nearest you. For a list of authorized Kramer Electronics resellers and/or Kramer Electronics authorized service providers, please visit our web site at www.kramerelectronics.com or contact the Kramer Electronics office nearest you.

In order to pursue any remedy under this limited warranty, you must possess an original, dated receipt as proof of purchase from an authorized Kramer Electronics reseller. If this product is returned under this limited warranty, a return authorization number, obtained from Kramer Electronics, will be required. You may also be directed to an authorized reseller or a person authorized by Kramer Electronics to repair the product.

If it is decided that this product should be returned directly to Kramer Electronics, this product should be properly packed, preferably in the original carton, for shipping. Cartons not bearing a return authorization number will be refused.

Limitation on Liability

THE MAXIMUM LIABILITY OF KRAMER ELECTRONICS UNDER THIS LIMITED WARRANTY SHALL NOT EXCEED THE ACTUAL PURCHASE PRICE PAID FOR THE PRODUCT. TO THE MAXIMUM EXTENT PERMITTED BY LAW, KRAMER ELECTRONICS IS NOT RESPONSIBLE FOR DIRECT, SPECIAL, INCIDENTAL OR CONSEQUENTIAL DAMAGES RESULTING FROM ANY BREACH OF WARRANTY OR CONDITION, OR UNDER ANY OTHER LEGAL THEORY. Some countries, districts or states do not allow the exclusion or limitation of relief, special, incidental, consequential or indirect damages, or the limitation of liability to specified amounts, so the above limitations or exclusions may not apply to you.

Exclusive Remedy

TO THE MAXIMUM EXTENT PERMITTED BY LAW, THIS LIMITED WARRANTY AND THE REMEDIES SET FORTH ABOVE ARE EXCLUSIVE AND IN LIEU OF ALL OTHER WARRANTIES, REMEDIES AND CONDITIONS, WHETHER ORAL OR WRITTEN, EXPRESS OR IMPLIED. TO THE MAXIMUM EXTENT PERMITTED BY LAW, KRAMER ELECTRONICS SPECIFICALLY DISCLAIMS ANY AND ALL IMPLIED WARRANTIES, INCLUDING, WITHOUT LIMITATION, WARRANTIES OF MERCHANTABILITY AND FITNESS FOR A PARTICULAR PURPOSE. IF KRAMER ELECTRONICS CANNOT LAWFULLY DISCLAIM OR EXCLUDE IMPLIED WARRANTIES UNDER APPLICABLE LAW, THEN ALL IMPLIED WARRANTIES COVERING THIS PRODUCT, INCLUDING WARRANTIES OF MERCHANTABILITY AND FITNESS FOR A PARTICULAR PURPOSE, SHALL APPLY TO THIS PRODUCT AS PROVIDED UNDER APPLICABLE LAW.

IF ANY PRODUCT TO WHICH THIS LIMITED WARRANTY APPLIES IS A "CONSUMER PRODUCT" UNDER THE MAGNUSON-MOSS WARRANTY ACT (15 U.S.C.A. §2301, ET SEQ.) OR OTHER APPLICABLE LAW, THE FOREGOING DISCLAIMER OF IMPLIED WARRANTIES SHALL NOT APPLY TO YOU, AND ALL IMPLIED WARRANTIES ON THIS PRODUCT, INCLUDING WARRANTIES OF MERCHANTABILITY AND FITNESS FOR THE PARTICULAR PURPOSE, SHALL APPLY AS PROVIDED UNDER APPLICABLE LAW.

Other Conditions

This limited warranty gives you specific legal rights, and you may have other rights which vary from country to country or state to state.

This limited warranty is void if (i) the label bearing the serial number of this product has been removed or defaced, (ii) the product is not distributed by Kramer Electronics or (iii) this product is not purchased from an authorized Kramer Electronics reseller. If you are unsure whether a reseller is an authorized Kramer Electronics reseller, please visit our Web site at www.kramerelectronics.com or contact a Kramer Electronics office from the list at the end of this document.

Your rights under this limited warranty are not diminished if you do not complete and return the product registration form or complete and submit the online product registration form. Kramer Electronics thanks you for purchasing a Kramer Electronics product. We hope it will give you years of satisfaction.



For the latest information on our products and a list of Kramer distributors, visit our Web site where updates to this user manual may be found.

We welcome your questions, comments, and feedback.

Web site: www.kramerelectronics.com

E-mail: info@kramerel.com



SAFETY WARNING

Disconnect the unit from the power supply before opening and servicing



P/N: 2900-000681



Rev: 5