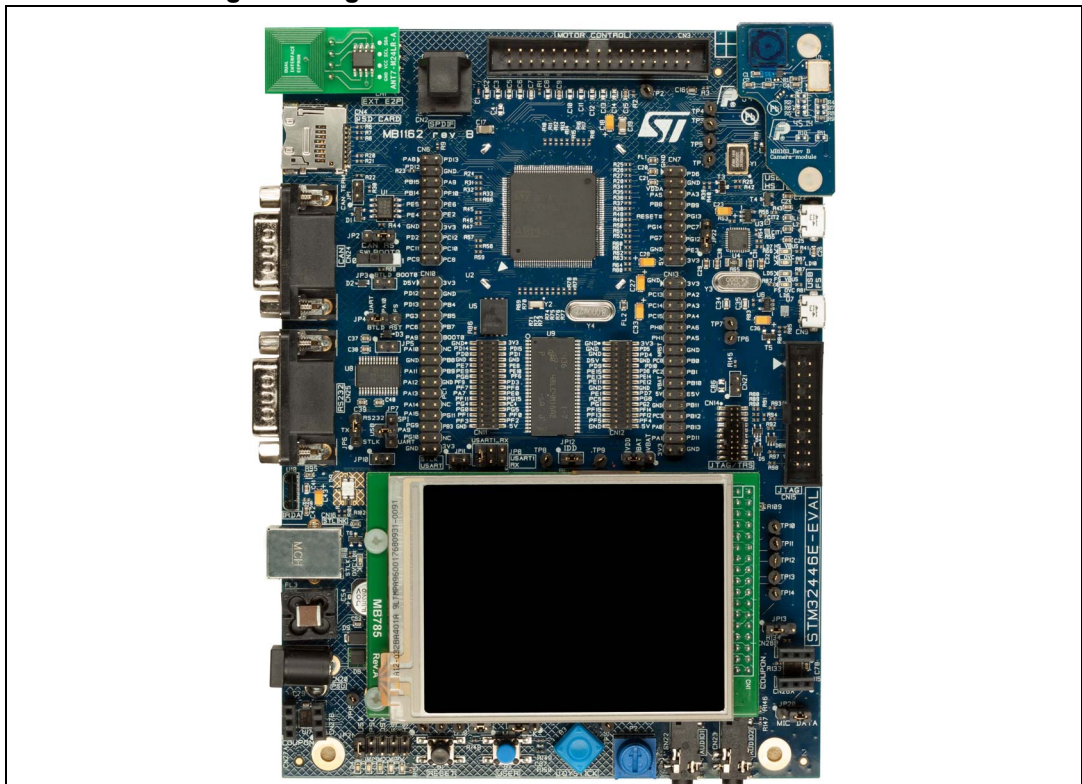


Evaluation board with STM32F446ZE MCU

Introduction

The STM32446E-EVAL evaluation board has been designed as a complete demonstration and development platform for the STMicroelectronics ARM® Cortex®-M4 with FPU core based STM32F446ZET6 microcontroller with SPDIF input, four I2C, four SPI, three I2S, two SAI, two CAN, three 12-bit ADC, two 12-bit DAC, up to 17 timers, USB OTG HS and FS, camera interface, FMC and QuadSPI interfaces, SDIO interface, 512 KB Flash memory and 128KB SRAM, JTAG and ETM trace debugging support. The full range of hardware features on the board can be used to evaluate all peripherals (USB HS & FS, USART, IrDA, CAN, digital microphones, audio codec, ADC and DAC, color LCD glass with touchscreen, SDRAM and QuadSPI Flash memories, I2C EEPROM, RF EEPROM, MicroSD card) and develop user's applications. Extension headers make it possible to easily connect a daughter board specific application. An ST-LINK/V2-1 is integrated on the board, as embedded in-circuit debugger and programmer for the STM32 MCU.

Figure 1. Figure 1: STM32446E-EVAL evaluation board



Contents

- 1 Overview 6**
 - 1.1 Features 6
 - 1.2 Demonstration software 6
 - 1.3 Order code 7
 - 1.4 Delivery recommendations 7

- 2 Hardware Layout and configuration 8**
 - 2.1 Embedded ST_LINK/V2-1 9
 - 2.1.1 Drivers 10
 - 2.1.2 ST-LINK/V2-1 firmware upgrade 10
 - 2.2 Power Supply 11
 - 2.3 Clock Source 13
 - 2.4 Reset Source 14
 - 2.5 Boot Option 15
 - 2.6 Audio 16
 - 2.7 USB OTG FS 18
 - 2.8 USB OTG HS 19
 - 2.9 RS232 and IrDA 19
 - 2.10 MicroSD card 20
 - 2.11 Potentiometer 20
 - 2.12 Analog input or output 21
 - 2.13 CAN 21
 - 2.14 Memories 22
 - 2.15 RF-EEPROM 22
 - 2.16 LCD Display and input devices 22
 - 2.17 MFX (Multi Function eXpander) 23
 - 2.18 Motor Control 24

- 3 Connectors 26**
 - 3.1 Motor control connector CN3 26
 - 3.2 RF_Connectors CN6 and CN7 27
 - 3.3 FMC_Connectors CN11 and CN12 28

3.4	Daughterboard connector CN13 and CN10	30
3.5	MicroSD connector CN4	31
3.6	RS232 connector CN25	32
3.7	ST-LINK/V2-1 USB Type B connector CN16	32
3.8	Audio jack CN22 and CN23	33
3.9	ST-LINK/V2-1 programming connector CN18	33
3.10	Power connector CN20	33
3.11	Analog input connector CN21	34
Appendix A STM32446E-EVAL IO assignment.		35
Appendix B Electrical schematics		41
Appendix C Mechanical dimensions.		60
Appendix D Appendix D: Overview of FCC and IC regulations		62
D.1	Part 15.19	62
D.2	Part 15.105	62
D.3	Part 15.21	62
D.4	Industry Canada	62
4	Revision History	63

List of tables

Table 1.	Power related jumpers and solder bridges	11
Table 2.	32 KHz Crystal Y2 related Solder Bridges	14
Table 3.	8 MHz Crystal Y4 related solder bridges	14
Table 4.	Boot0 switch	15
Table 5.	Boot0 & Boot1 Related Jumpers	15
Table 6.	Audio related jumpers	17
Table 7.	USB_OTG_FS related jumpers	18
Table 8.	RS232 & IrDA related jumpers	19
Table 9.	CAN related jumpers	22
Table 10.	LCD modules	23
Table 11.	MFX signals	23
Table 12.	Motor Control connector CN13	26
Table 13.	Connector CN6	27
Table 14.	Connector CN7	27
Table 15.	FMC Connectors CN11	28
Table 16.	FMC Connectors CN12	29
Table 17.	DB_Connectors CN13	30
Table 18.	DB_Connectors CN10	31
Table 19.	MicroSD connector CN4	32
Table 20.	RS232 connector CN25	32
Table 21.	USB type B connector CN16	33
Table 22.	Analog input-output connector CN4	34
Table 23.	IOs assignment	35
Table 24.	Mechanical dimension	61
Table 25.	Document Revision History	63

List of figures

Figure 1.	Figure 1: STM32446E-EVAL evaluation board.	1
Figure 2.	Hardware Block Diagram	8
Figure 3.	STM32446E-EVAL evaluation board layout	9
Figure 4.	Updating the list of drivers in device manager	10
Figure 5.	Solder bridge to be added on bottom side for Motor control.	21
Figure 6.	PCB underside rework for CAN	22
Figure 7.	PCB underside rework for Motor Control	25
Figure 8.	Motor Control connector CN3	26
Figure 9.	MicroSD connector CN4 (front view)	31
Figure 10.	RS232 connector CN25 (front view)	32
Figure 11.	USB type B connector CN16	33
Figure 12.	Power supply connector CN20	34
Figure 13.	Analog input-output connector CN21	34
Figure 14.	MCU 1.	41
Figure 15.	MCU 2.	42
Figure 16.	Power	43
Figure 17.	USB OTG HS	44
Figure 18.	USB OTG FS	45
Figure 19.	ST-LINK/V2-1	46
Figure 20.	MFX V3.	47
Figure 21.	Peripherals	48
Figure 22.	CAN, RS232 / IrDA	49
Figure 23.	Audio.	50
Figure 24.	Memory.	51
Figure 25.	Motor Control	52
Figure 26.	STM32446E-EVAL LCD	53
Figure 27.	JTAG and trace.	54
Figure 28.	Camera connector	55
Figure 29.	Connectors	56
Figure 30.	FMC connectors	57
Figure 31.	3.2"LCD module with both SPI and 16bit interface.	58
Figure 32.	Camera module	59
Figure 33.	Mechanical dimensions	60

1 Overview

1.1 Features

- STM32F446ZET6 microcontroller.
- 3.2" 240x320 TFT color LCD with resistive touchscreen
- 2048 x 1536 camera module
- SAI stereo audio DAC, audio jacks which support headset with microphone
- Stereo digital microphones connected to DAC or to MCU
- Connectors for microphone coupon board
- SPDIF optical input connector
- Joystick with 4-direction control and selector
- Reset and user buttons
- Potentiometer
- 4 color user LEDs
- 32MB QuadSPI Flash
- 4M x 16-bit SDRAM
- 2GB (or more) MicroSD card
- RF-EEPROM
- USB OTG HS and FS with micro-AB
- Micro-AB connector
- RS232 communication
- CAN 2.0A/B compliant communication
- IrDA transceiver
- Embedded ST-LINK/V2-1
- JTAG/SWD and ETM trace debug support
- Five 5 V power supply options:
 - Power jack
 - ST-LINK USB connector
 - USB FS connector
 - USB HS connector
 - Daughter board
- RTC with backup battery
- Motor control connector
- Extension connectors for daughter board or wrapping board and memory connectors

1.2 Demonstration software

Demonstration software is preloaded in the Flash memory of the board for easy demonstration of the device peripherals in stand-alone mode. For more information and to download the latest version available, refer to the STM32446E-EVAL demonstration software available on the web: www.st.com.

1.3 Order code

To order the evaluation board based on STM32F446ZE MCU, use the order code STM32446E-EVAL.

1.4 Delivery recommendations

Before using the board for the first time, it must be verified that nothing was damaged during shipment and that no components are unplugged or lost. When the board is extracted from its plastic bag, it must be checked that no component remains in the bag.

The main components to verify are:

1. The MicroSD card which may have been ejected from the CN4 connector (top left corner of the board).
2. The dual-interface EEPROM board (ANT7-M24LR-A) which may have been unplugged from the CN1 connector (top left corner of the board).

Note: The plastic protection on the camera should be removed carefully as the connection is very fragile.

Note: For all information concerning the version of the MCU used on the board, its specification and possible related limitations, visit the ST web site (www.st.com) to download relevant datasheet and errata sheet.

2 Hardware Layout and configuration

The STM32446E-EVAL evaluation board is designed around the STM32F446ZET6 microcontroller in a 144-pin LQFP package. The hardware block diagram [Figure 2](#) illustrates the connection between STM32F446ZET6 and peripherals (Camera, RS232, Audio DAC, microphone ADC, TFT LCD, CAN, IrDA, MicroSD card, RF E2PROM and others). [Figure 3](#) will help the user to locate these features on the actual evaluation board.

Figure 2. Hardware Block Diagram

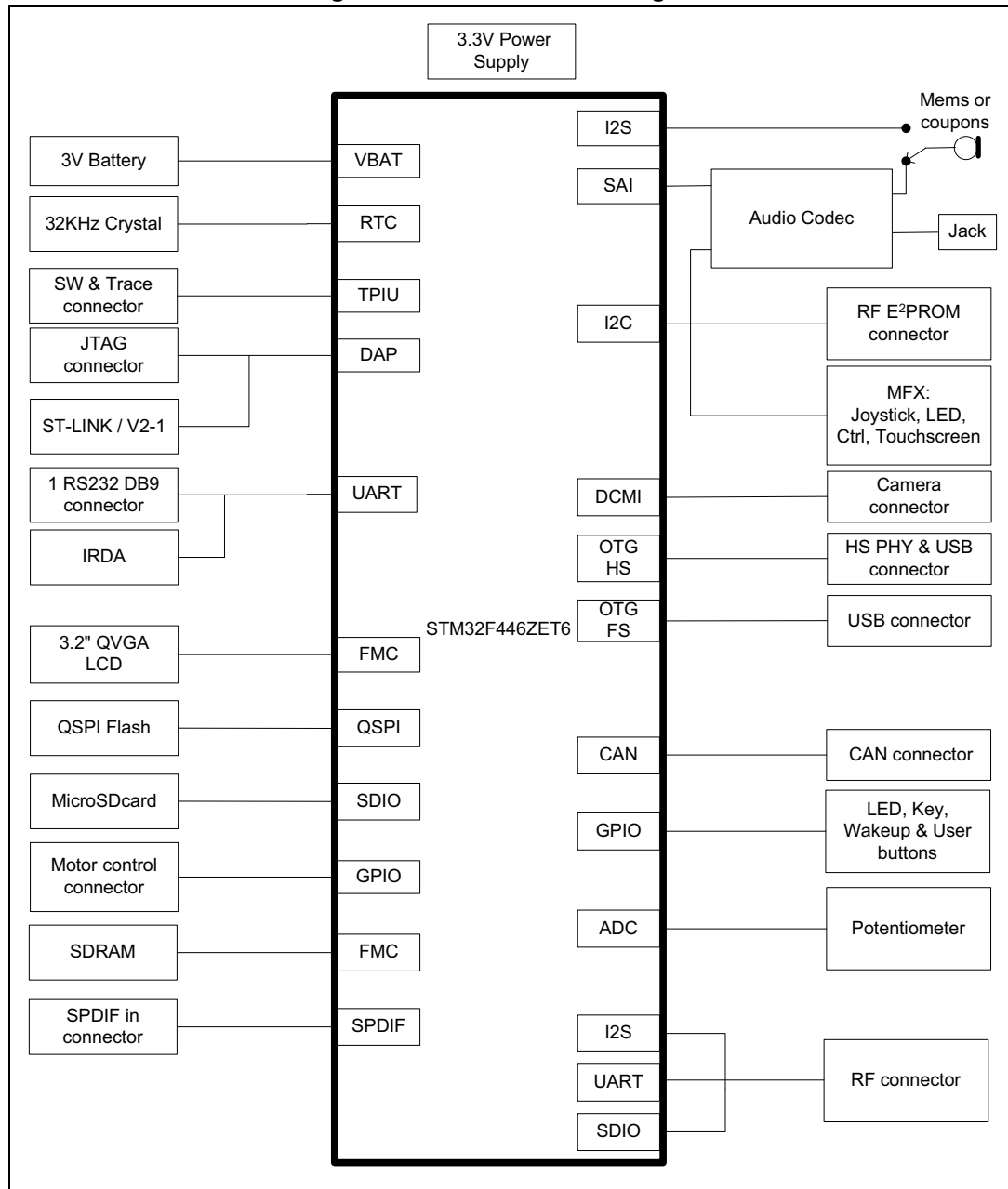
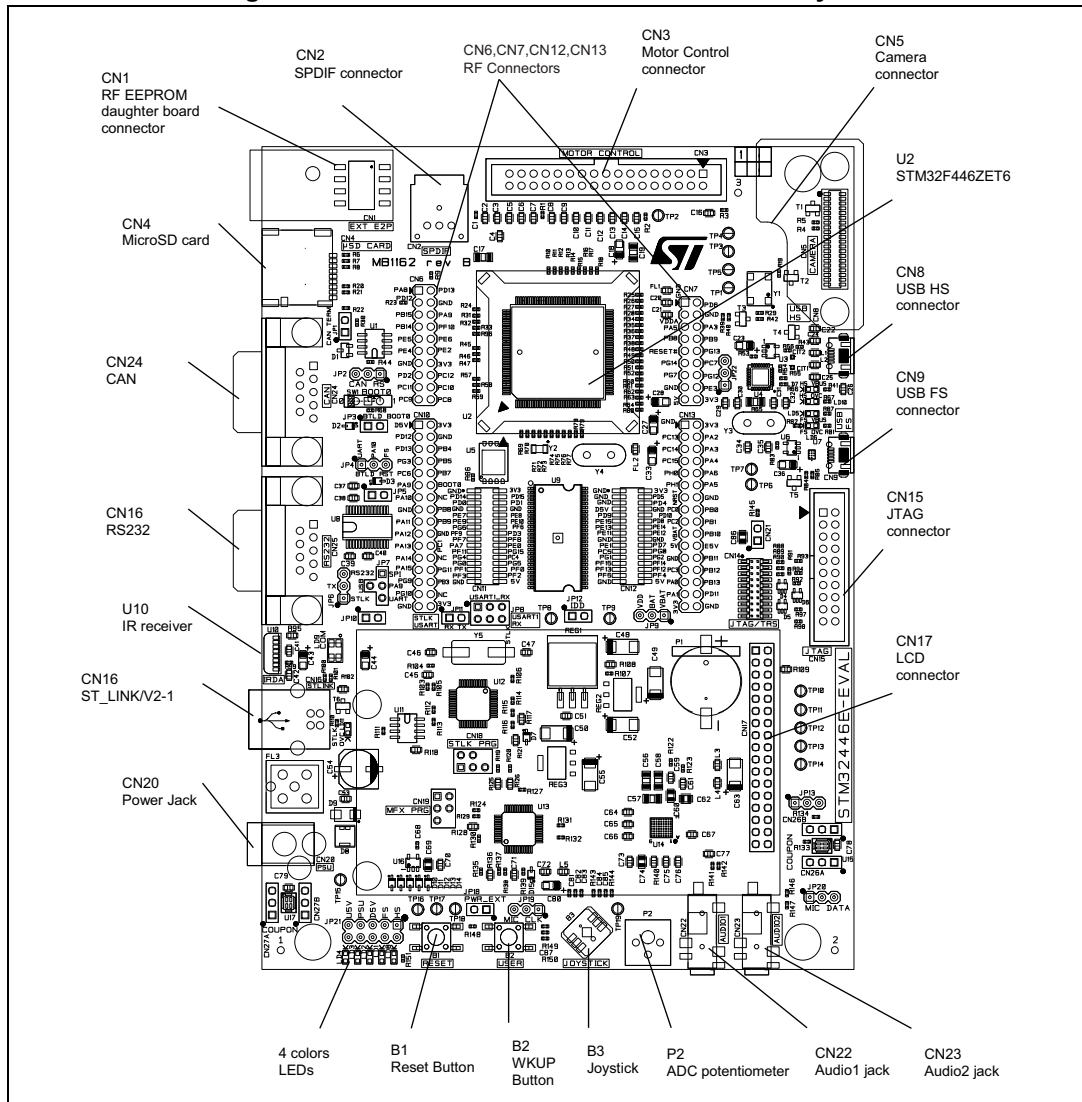


Figure 3. STM32446E-EVAL evaluation board layout



2.1 Embedded ST_LINK/V2-1

The ST-LINK/V2-1 programming and debugging tool is integrated on the STM32446E-EVAL evaluation board.

The embedded ST-LINK/V2-1 supports only SWD for STM32 devices. For information about debugging and programming features the user can refer to the User Manual UM1075 (ST-LINK/V2 in-circuit debugger/programmer for STM8 and STM32), which describes in detail all the ST-LINK/V2 features.

The changes versus ST-LINK/V2 version are listed below:

- New features supported on ST-LINK/V2-1:
 - USB software re-enumeration
 - Virtual com port interface on USB
 - Mass storage interface on USB
 - USB power management request for more than 100 mA power on USB
- Features not supported on ST-LINK/V2-1:
 - SWIM interface
 - Minimum supported application voltage limited to 3 V
- Known limitation:
 - Activating the readout protection on ST-LINK/V2-1 target, prevents the target application from running afterwards. The target readout protection must be kept disabled on ST-LINK/V2-1 boards.

Note: It is possible to power the board via CN16 (Embedded ST-LINK/V2-1 USB connector) even if an external tools is connected to CN14 or CN15 (SWD connector).

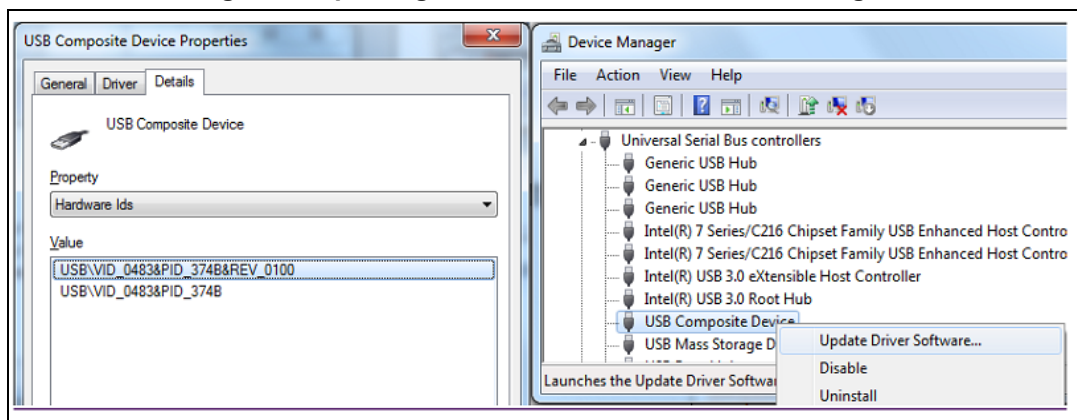
2.1.1 Drivers

The ST-LINK/V2-1 requires a dedicated USB driver for Windows Vista 7 and 8, which can be found on www.st.com. On Windows XP the ST-LINK/V2-1 driver requires WinUsb to be installed, before using the ST-LINK/V2-1 (either available from Microsoft website or included in the USB driver for ST-LINK/V2 for XP).

In case the STM32446E-EVAL evaluation board is connected to the PC before the driver is installed, some STM32446E-EVAL interfaces may be declared as “Unknown” in the PC device manager. In this case the user must install the driver files, and from the device manager he must update the driver of the connected device.

Note: Prefer using the “USB Composite Device” handle for a full recovery.

Figure 4. Updating the list of drivers in device manager



2.1.2 ST-LINK/V2-1 firmware upgrade

The ST-LINK/V2-1 embeds a firmware upgrade mechanism for in-situ upgrade through the USB port. As the firmware may evolve during the life time of the ST-LINK/V2-1 product (for example new functionalities, bug fixes, support for new microcontroller families), it is

recommended to visit www.st.com, before starting to use the STM32446E-EVAL board and periodically, in order to stay up-to-date with the latest firmware version.

2.2 Power Supply

STM32446E-EVAL evaluation board is designed to be powered by 5 V DC power supply and to be protected by PolyZen from wrong power plug-in event. It is possible to configure the evaluation board to use any of the following five sources for the power supply:

- 5 V DC power adapter connected to CN20 (PSU on silkscreen), the Power Jack on the board. The external power supply is not provided with the board.
- 5 V DC power with 500 mA limitation from CN9, the USB_OTG_FS Micro-AB connector
- 5 V DC power with 500 mA limitation from CN8, the USB_OTG_HS Micro-AB connector
- 5 V DC power with 300 mA limitation from CN16, the ST-LINK/V2 USB
- 5 V DC power from both CN10 and CN12, the extension connector for daughterboard

The power supply is configured using JP12, JP21 and JP9 as described in [Table 2: 32 KHz Crystal Y2 related Solder Bridges](#).

Table 1. Power related jumpers and solder bridges

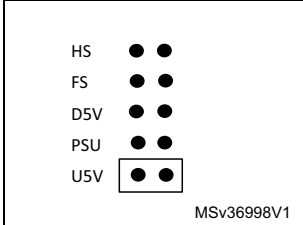
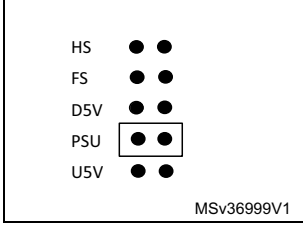
Jumper	Description
JP12	MCU_VDD is connected to 3.3 V power when JP12 is closed and MCU current consumption measurement can be done manually by multi-meter when JP12 is open. Default setting: Fitted.
JP21	To select the ST-LINK/V2-1 USB connector (CN16) power supply, set JP21 on U5V position as shown (default setting):
	 <p>MSv36998V1</p>
JP21	To select power supply jack (CN20 PSU) power supply, set JP21 on PSU as shown:
	 <p>MSv36999V1</p>

Table 1. Power related jumpers and solder bridges (continued)

Jumper	Description										
JP21	To select daughterboard connector (CN10 and CN12) power supply, set JP21 on D5V as shown: <div data-bbox="1110 416 1406 645" style="border: 1px solid black; padding: 5px; margin-top: 10px;"> <table style="width: 100%; border-collapse: collapse;"> <tr><td style="width: 30px;">HS</td><td style="text-align: center;">● ●</td></tr> <tr><td>FS</td><td style="text-align: center;">● ●</td></tr> <tr><td>D5V</td><td style="text-align: center;">● ●</td></tr> <tr><td>PSU</td><td style="text-align: center;">● ●</td></tr> <tr><td>U5V</td><td style="text-align: center;">● ●</td></tr> </table> <p style="text-align: right; font-size: small;">MSv37000V1</p> </div>	HS	● ●	FS	● ●	D5V	● ●	PSU	● ●	U5V	● ●
	HS	● ●									
	FS	● ●									
	D5V	● ●									
PSU	● ●										
U5V	● ●										
To select USB-OTG FS (CN9) power supply, set JP21 on FS as shown: <div data-bbox="1110 685 1406 913" style="border: 1px solid black; padding: 5px; margin-top: 10px;"> <table style="width: 100%; border-collapse: collapse;"> <tr><td style="width: 30px;">HS</td><td style="text-align: center;">● ●</td></tr> <tr><td>FS</td><td style="text-align: center;">● ●</td></tr> <tr><td>D5V</td><td style="text-align: center;">● ●</td></tr> <tr><td>PSU</td><td style="text-align: center;">● ●</td></tr> <tr><td>U5V</td><td style="text-align: center;">● ●</td></tr> </table> <p style="text-align: right; font-size: small;">MSv37001V1</p> </div>	HS	● ●	FS	● ●	D5V	● ●	PSU	● ●	U5V	● ●	
HS	● ●										
FS	● ●										
D5V	● ●										
PSU	● ●										
U5V	● ●										
To select USB-OTG HS (CN8) power supply, set JP21 on HS as shown: <div data-bbox="1110 954 1406 1182" style="border: 1px solid black; padding: 5px; margin-top: 10px;"> <table style="width: 100%; border-collapse: collapse;"> <tr><td style="width: 30px;">HS</td><td style="text-align: center;">● ●</td></tr> <tr><td>FS</td><td style="text-align: center;">● ●</td></tr> <tr><td>D5V</td><td style="text-align: center;">● ●</td></tr> <tr><td>PSU</td><td style="text-align: center;">● ●</td></tr> <tr><td>U5V</td><td style="text-align: center;">● ●</td></tr> </table> <p style="text-align: right; font-size: small;">MSv37002V1</p> </div>	HS	● ●	FS	● ●	D5V	● ●	PSU	● ●	U5V	● ●	
HS	● ●										
FS	● ●										
D5V	● ●										
PSU	● ●										
U5V	● ●										
To select power supply jack (CN20) power supply to both STM32446E-EVAL and daughterboard connected on CN10 and CN13, set JP21 on PSU and D5V as shown (daughterboard must not have its own power supply connected) <div data-bbox="1110 1294 1406 1525" style="border: 1px solid black; padding: 5px; margin-top: 10px;"> <table style="width: 100%; border-collapse: collapse;"> <tr><td style="width: 30px;">HS</td><td style="text-align: center;">● ●</td></tr> <tr><td>FS</td><td style="text-align: center;">● ●</td></tr> <tr><td>D5V</td><td style="text-align: center;">● ●</td></tr> <tr><td>PSU</td><td style="text-align: center;">● ●</td></tr> <tr><td>U5V</td><td style="text-align: center;">● ●</td></tr> </table> <p style="text-align: right; font-size: small;">MSv37003V1</p> </div>	HS	● ●	FS	● ●	D5V	● ●	PSU	● ●	U5V	● ●	
HS	● ●										
FS	● ●										
D5V	● ●										
PSU	● ●										
U5V	● ●										
JP9	To connect MCU Vbat to 3.3 V power, set JP9 as shown (default setting): <div data-bbox="1295 1570 1406 1659" style="border: 1px solid black; padding: 5px; margin-top: 10px;"> <table style="width: 100%; border-collapse: collapse;"> <tr><td style="width: 20px;">1</td><td style="width: 20px;">2</td><td style="width: 20px;">3</td></tr> <tr><td style="text-align: center;">●</td><td style="text-align: center;">●</td><td style="text-align: center;">●</td></tr> </table> </div>	1	2	3	●	●	●				
	1	2	3								
●	●	●									
To connect MCU Vbat to the battery, set JP9 as shown: <div data-bbox="1295 1704 1406 1792" style="border: 1px solid black; padding: 5px; margin-top: 10px;"> <table style="width: 100%; border-collapse: collapse;"> <tr><td style="width: 20px;">1</td><td style="width: 20px;">2</td><td style="width: 20px;">3</td></tr> <tr><td style="text-align: center;">●</td><td style="text-align: center;">●</td><td style="text-align: center;">●</td></tr> </table> </div>	1	2	3	●	●	●					
1	2	3									
●	●	●									

Note: LED LD8 is lit when the STM32446E-EVAL evaluation board is powered by 5 V correctly.

STM32446E-EVAL evaluation board can be powered from ST-LINK USB connector CN16 (U5V), but only ST-LINK part is powered before USB enumeration, because host PC only provides 100 mA to the boards at that time. During the USB enumeration, STM32446E-EVAL board asks for the 300 mA power to the Host PC. If the host is able to provide the required power, the enumeration finishes by a “SetConfiguration” command and then, the power transistor U11 (ST890) is switched ON, the red LED LD8 is turned ON, thus STM32446E-EVAL board can consume maximum 300 mA current, but not more. If the host is not able to provide such requested current, the enumeration fails, therefore the ST890 (U11) remains OFF and the 3.3 V part of the board will not be powered. As consequence, the red LED LD8 remains turned OFF. In such case it is mandatory to use an external power supply as extra power supply.

E5V (from PSU) or D5V can be used as external power supply, in case current consumption of STM32446E-EVAL board exceeds the allowed current on USB. In this condition it is still possible to use USB for communication for programming or debugging only, but it is mandatory to power the board first using E5V or D5V, then connect the USB cable to the PC. Proceeding in this way, ensures that the enumeration succeeds thanks to the external power source.

The following power sequence procedure must be respected:

1. Connect jumper JP21 for PSU or D5V side
2. Check that JP18 is removed (PWR_EXT)
3. Connect the external power source to CN20 (PSU) or D5V (daughterboard mounted)
4. Check red LED LD8 is turned ON
5. Connect the PC to USB connector CN16

If this order is not respected, the board may be powered by VBUS first, then E5V or D5V, and the following risks may be encountered:

1. If more than 300 mA current is needed by the board, the PC may be damaged or current can be limited by PC. As a consequence the board is not powered correctly.
2. 300 mA will be requested at enumeration (since JP18 must be OFF), so there is risk that request is rejected and enumeration does not succeed, if PC can't provide such current. Consequently the board is not powered (LED LD8 remains OFF).

Note: In case the board is powered by an USB charger, there is no USB enumeration, so the led LD8 remains set to OFF permanently and the board is not powered. Only in this specific case the jumper JP18 needs to be set to ON, to allow the board to be powered anyway.

Note: When the board is powered by ST-Link, the current is limited by U11 and the LED LD11 is turned ON in case of over current detection.

2.3 Clock Source

Two clock sources are available on STM32446E-EVAL evaluation board for STM32F446ZET6 and RTC embedded (see [Table 2: 32 KHz Crystal Y2 related Solder Bridges](#) and [Table 3: 8 MHz Crystal Y4 related solder bridges](#)):

- Y2, 32KHz Crystal for embedded RTC
- Y4, 8MHz Crystal with socket for STM32F446ZET6 Microcontroller, Y3, 24MHz Crystal for USB OTG HS.
- Y5, 8MHz Crystal for ST_LINK.

Table 2. 32 KHz Crystal Y2 related Solder Bridges

Solder bridge	Description
SB108	PC14 is connected to 32KHz crystal when SB108 is open (default setting).
	PC14 is connected to DB_CONNECTOR CN13 when SB108 is closed. In such case SB43 must be removed to avoid disturbance due to the 32 Khz quartz
SB107	PC15 is connected to 32KHz crystal when SB107 is open (default setting).
	PC15 is connected to extension connector CN13 when SB107 is closed. In such case SB56 must be removed to avoid disturbance due to the 32 Khz quartz

Table 3. 8 MHz Crystal Y4 related solder bridges

Solder bridge	Description
SB106	PH0 is connected to 8 MHz crystal when SB106 is open (default setting).
	PH0 is connected to extension connector CN13 when SB106 is closed. In such case SB69 must be removed to avoid disturbance due to the 32 Khz quartz.
SB105	PH1 is connected to 8 MHz crystal when SB105 is open (default setting).
	PH1 is connected to extension connector CN26 when SB105 is closed. In such case SB70 must be removed to avoid disturbance due to the 8 Mhz quartz.

2.4 Reset Source

The reset signal of STM32446E-EVAL evaluation board is low active and the reset sources include:

- Reset button B1
- DB_Connectors from CN13 pin 13
- Embedded ST-LINK/V2-1
- RS232 connector CN25 pin 8 (CTS) for ISP.

Note: The jumper JP5 should be set to control RESET by pin8 of RS232 connector CN25 (CTS signal).

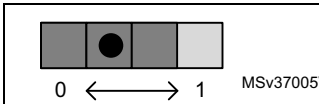
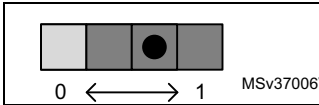
2.5 Boot Option

The STM32446E-EVAL evaluation board is able to boot from:

- Embedded User Flash
- System memory with boot loader for ISP
- Embedded SRAM for debugging

The BOOT0 option is configured by setting SW1.

Table 4. Boot0 switch

Switch	Description
SW1	STM32446E-EVAL boots from User Flash when SW1 is configured as shown (default setting): 
	STM32446E-EVAL boots from User RAM or System memory when SW1 is configured as shown: 

BOOT0 can also be configured via RS232 connector CN25.

Table 5. Boot0 & Boot1 Related Jumpers

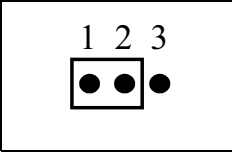
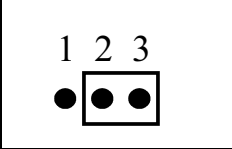
Jumper	Description
JP22	PB2 is used as ULPI_D4 (Camera interface) when JP22 is set as shown on the right (default setting): 
	PB2 is used as BOOT1 and set at level 1 when JP22 is set as shown on the right: 

Table 5. Boot0 & Boot1 Related Jumpers (continued)

Jumper	Description						
JP22	PB2 is used as BOOT1 and pulled down (level zero) when jumper is removed from JP22 as shown on the right: <div data-bbox="1179 398 1406 546" style="border: 1px solid black; padding: 5px; display: inline-block; margin-left: 20px;"> <table style="border-collapse: collapse; text-align: center;"> <tr> <td style="padding: 2px 10px;">1</td> <td style="padding: 2px 10px;">2</td> <td style="padding: 2px 10px;">3</td> </tr> <tr> <td style="padding: 2px 10px;">●</td> <td style="padding: 2px 10px;">●</td> <td style="padding: 2px 10px;">●</td> </tr> </table> </div>	1	2	3	●	●	●
1	2	3					
●	●	●					
JP5	The Bootloader_BOOT0 is also managed by pin 6 of connector CN25 (RS232 DSR signal) when JP5 is closed. This configuration is used for boot loader application only. Default setting: Not fitted						

2.6 Audio

An audio codec WM8994ECS/R with 4 DACs & 2ADCs inside, is connected to SAI interface of STM32F446ZE, to support TDM feature on SAI port. This feature is able to implement audio recording on digital Microphone & analog Microphone and audio playback of different audio stream on headphones.

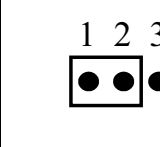
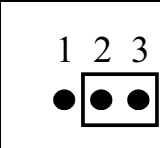
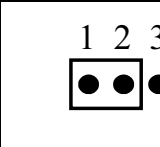
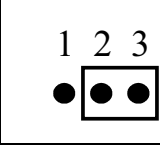
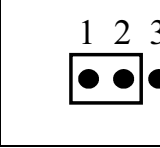
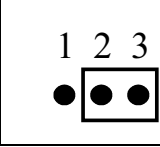
It communicates with STM32F446ZE via I2C4 bus which is shared with camera module, RF-EEPROM & MFX (Multi Function eXpander).

The analog microphone on the headset is connected to ADC of WM8994ECS/R through audio jack CN22. External speakers can be connected to WM8994ECS/R via audio jack CN23.

Two Digital Microphones (MEMs microphone) MP34DT01TR are on STM32446E-EVAL evaluation board. They can be connected to either audio codec or I2S port of STM32F446, by setting jumpers as shown in [Table 6: Audio related jumpers](#). The coupon connectors CN26 & CN27 can be used to support MEMS microphone evaluation board STEVAL-MKI129V1, after removing SB1 & SB133.

An optical connector CN2 is implemented on STM32446E-EVAL, to receive external audio data which is compatible with SPDIF spec.

Table 6. Audio related jumpers

Jumper	Description
JP20	Data signal on digital microphone is connected to audio codec when JP20 is set as shown on the right (default setting): 
	Data signal on digital microphone is connected to I2S port of STM32F446ZE when JP20 is set as shown on the right: 
JP19	Clock signal on digital microphone is connected to audio codec when JP19 is set as shown on the right (default setting): 
	Clock signal on digital microphone is connected to Timer4 output (PD13) of STM32F446ZE, used to divide by 2 the I2S3_CK, when JP19 is set, as shown on the right (it is also needed to close SB23 & SB24 to use Timer 4 to manage I2S3_CK): 
JP13	Digital microphone power source is connected to +3.3V power when JP13 is set as shown to the right (default setting): 
	Digital microphone power source is connected to MICBIAS1 from WM8994ECS/R when JP13 is set as shown to the right: 

Note: I2C address of WM8994ECS/R is 0b0011010.

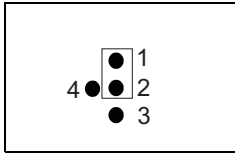
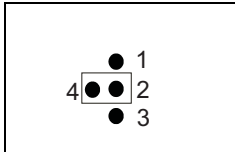
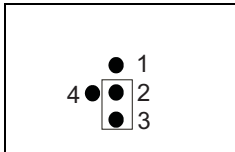
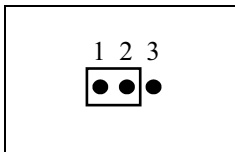
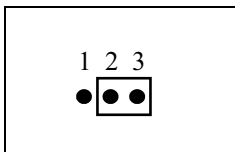
2.7 USB OTG FS

STM32446E-EVAL evaluation board supports USB OTG full speed communication via a USB Micro-AB connector (CN9) and USB power switch (U6) connected to VBUS. The evaluation board can be powered by this USB connector (JP21 in position FS) at 5 V DC with 500 mA current limitation. A green LED LD5 will be lit in two conditions:

- STM32446E-EVAL works as an USB host and power switch (U6) is ON
- STM32446E-EVAL works as a USB device if VBUS is powered by another USB host

A red LED LD5 will be lit when over-current is detected by the power switch U6.

Table 7. USB_OTG_FS related jumpers

Jumper	Description
JP7	STM32F446 port PA9 is used as USART1_TX (in conjunction with JP6) when JP7 is set as shown below (see Warning): 
	STM32F446 port PA9 is connected to USB_FS_VBUS when JP7 is set as shown below (see Warning): 
	STM32F446 port PA9 is connected to SPI when JP7 is set as shown below (see Warning): 
JP4	STM32F446 port PA10 is used as USART1_RX (in conjunction with JP8) when JP4 is set as shown below (see Warning): 
	STM32F446 port PA10 is connected to USB_FS_ID when JP4 is set as shown below (see Warning): 

Warning: There is an error on silkscreen of MB1162 PCB rev B:
 - JP7 pin 1 is named SPI instead of UART
 - JP7 pin 3 is named UART instead of SPI

2.8 USB OTG HS

STM32446E-EVAL evaluation board supports USB OTG high speed communication via a USB Micro-AB connector (CN8) and USB HS PHY USB3300 (U4). The evaluation board can be powered by this USB connector (CN8) at 5V DC with 500 mA current limitation. USB power switch (U3) is connected on VBUS and provides power to CN8 (if SB131 is closed).

Green LED LD7 will be lit when either:

- power switch (U3) is ON and STM32446E-EVAL works as a USB host
- VBUS is powered by another USB host when STM32446E-EVAL works as an USB device.

Red LED LD10 will be lit when over-current occurs.

JP22 should be configured as explained in [Table 5: Boot0 & Boot1 Related Jumpers](#).

2.9 RS232 and IrDA

The RS232 transceiver U8 (with Hardware flow control CTS & RTS) connected to D-type 9-pins RS232 connector CN25, and IrDA transceiver U10, are connected to USART1 of STM32F446ZET6, which can be also shared with ST-LINK USART.

The signal Bootloader_RESET (shared with CTS signal) & Bootloader_BOOT0 (shared with DSR signal) are added on RS232 connector CN8 for ISP support.

USART1 selection is done by setting JP6 and JP8, refer to [Table 8: RS232 & IrDA related jumpers](#) for detail.

Table 8. RS232 & IrDA related jumpers

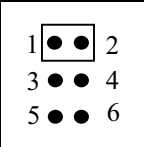
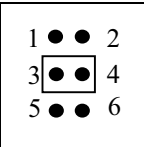
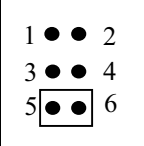
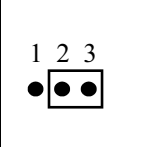
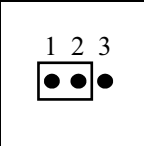
Jumper	Description
JP8	RS232_RX output of RS232 transceiver is connected to PA10 (USART1_RX in conjunction with JP4), when JP8 is set as shown below (default setting): 
	IrDA_RX from IrDA transceiver is connected to PA10 (USART1_RX in conjunction with JP4) when JP8 is set as shown below: 

Table 8. RS232 & IrDA related jumpers (continued)

Jumper	Description
JP8	<p>USART_TX from ST-LINK is connected to PA10 (USART1_RX in conjunction with JP4) to support virtual com port when JP8 is set as shown below:</p> 
JP6	<p>RS232_TX input of RS232 transceiver is connected to PA9 (USART1_TX in conjunction with JP7) when JP6 is set as shown below (default setting):</p> 
	<p>RS232_TX from ST-LINK is connected to PA9 (USART1_TX in conjunction with JP7) to support virtual com port when JP6 is set as shown below:</p> 

2.10 MicroSD card

The 4GB (or more) MicroSD card is connected to SDIO interface of STM32F446ZET6. MicroSD card detection is managed by MFX_IO15, configured with internal pull-up. The following solder bridges are closed to support MicroSD card by default: SB26, SB27, SB28, SB29, SB30, SB47.

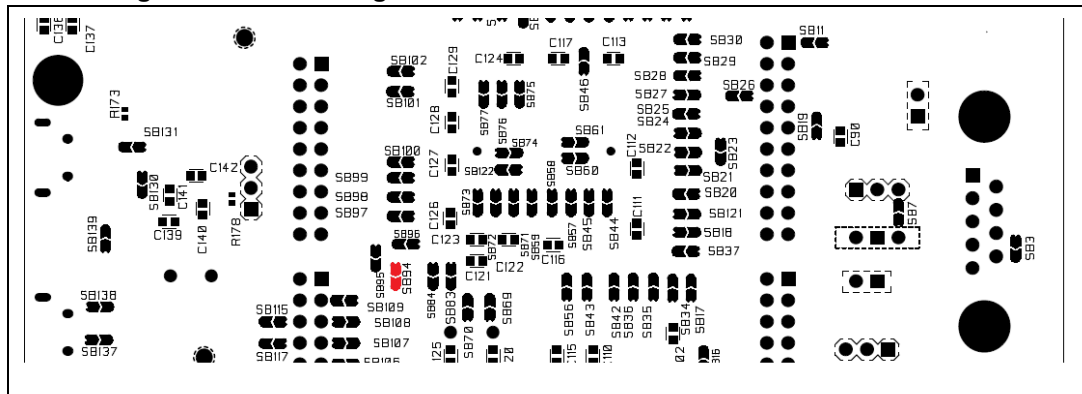
2.11 Potentiometer

A 10 KΩ potentiometer P2 is connected to PA4 of the STM32F446ZET6 on the board.

The following solder bridges must be closed to connect potentiometer to PA4: SB91, SB92, SB94, SB103. The potentiometer is not connected by default to PA4, since SB94, that is marked in red in [Figure 5](#), is opened to support Camera interface by default.

A low pass filter can be implemented, by replacing SB92 and C86 with the right value of resistor and capacitor, as requested by end user's application.

Figure 5. Solder bridge to be added on bottom side for Motor control



2.12 Analog input or output

The analog input or output connector CN21 can be connected to PA4 of STM32F446ZET6, used as ADC or DAC analog IO.

Solder bridge SB91 must be opened and SB92, SB94, SB103 must be closed to connect CN21 to PA4. CN21 is not connected by default to PA4, since SB94 is opened to support Camera interface by default.

In case CN21 is used as ADC, input low pass filter can be implemented by replacing SB92 and C86 with right value of resistor and capacitor, as requested by end user's application. In case CN21 is used as DAC output, a low pass filter can be implemented by replacing SB103 and C86 with the right value of resistor and capacitor, as requested by end user's application.

2.13 CAN

STM32446E-EVAL evaluation board supports one channels of CAN2.0 A/B compliant CAN bus communication based on 3.3 V CAN transceiver. The High-speed mode, standby mode and slope control mode are available and can be selected by setting JP2.

SB19, marked in red in [Figure 6](#), must be closed to connect CAN1_RX to PB8. CAN1_RX is not connected by default to PB8, since SB19 is open to support Camera interface by default.

Figure 6. PCB underside rework for CAN

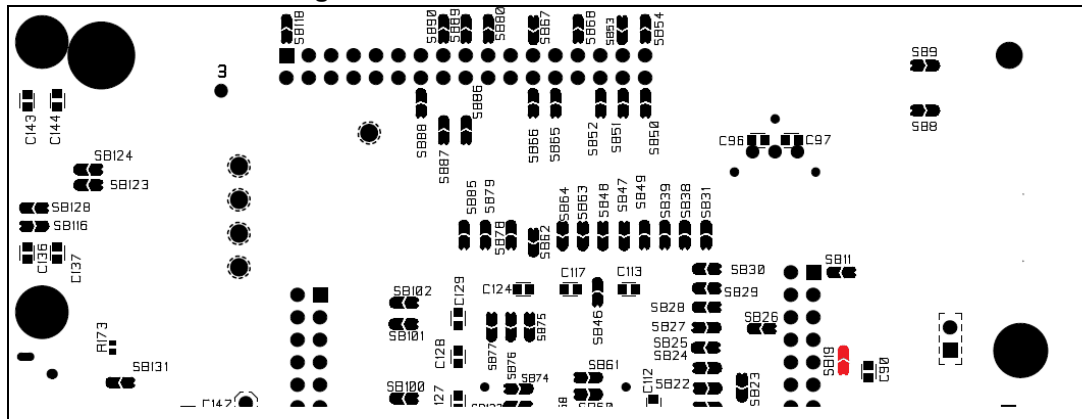


Table 9. CAN related jumpers

Jumper	Description
JP2	CAN transceiver is working in standby mode when JP2 is set as shown to the right:
	CAN transceiver is working in high-speed mode when JP2 is set as shown to the right (default setting):
	CAN transceiver is working in slope control mode when JP2 is open.
JP1	CAN terminal resistor is enabled when JP1 is fitted. Default setting: Not fitted

2.14 Memories

8M Bytes SDRAM is connected to SDRAM Bank1 of FMC interface of STM32F446ZE. All signals for memory are also connected to extension connectors CN11 and CN12.

2.15 RF-EEPROM

An RF-EEPROM module ANT7-M24LR-A (MB1020A-02) is mounted on connector CN12 and connected to the common I2C4 bus of STM32F446ZET6. The I2C address of the RF-EEPROM daughterboard is 0b1010000.

2.16 LCD Display and input devices

The 3.2" TFT color LCD connected to FMC bus and 4 general purpose color LEDs (LD 1, 2, 3, 4) are available as display devices. A touchscreen, a 4-direction joystick with selection key and wakeup/tamper button (B2) are available as input devices and connected to MFX.

Table 10. LCD modules

3.2" TFT LCD connector CN17					
Pin	Description	Pin connection	Pin	Description	Pin connection
1	CS	FMC_NE1	18	PD14	FMC_D12
2	RS	FMC_A0	19	PD15	FMC_D13
3	WR/SCL	FMC_NWE	20	PD16	FMC_D14
4	RD	FMC_NOE	21	PD17	FMC_D15
5	RESET	RESET#	22	BL_VND	GND
6	PD1	FMC_D0	23	BL_Control	VDD
7	PD2	FMC_D1	24	VDD	+3V3
8	PD3	FMC_D2	25	VCI	+3V3
9	PD4	FMC_D3	26	GND	GND
10	PD5	FMC_D4	27	GND	GND
11	PD6	FMC_D5	28	BL_VDD	VDD
12	PD7	FMC_D6	29	SDO	NC
13	PD8	FMC_D7	30	SDI	NC
14	PD10	FMC_D8	31	XL	Touchscreen X-
15	PD11	FMC_D9	32	XR	Touchscreen X+
16	PD12	FMC_D10	33	YD	Touchscreen Y-
17	PD13	FMC_D11	34	YU	Touchscreen Y+

2.17 MFX (Multi Function eXpander)

The Multi Function eXpander (abbreviated MFX) is used on STM32446E-EVAL as IO expander and as ADC inputs to manage the LCD touch screen. The communication interface between MFX and STM32F446E is the common I2C4 bus.

Table 11. MFX signals

Pin number of MFX	Pin name of MFX	MFX functions	Function of STM32756G-EVAL	Direction (For MFX)	Terminal device
3	PC14	MFX_GPO4	unused	Output	-
5	PH0	MFX_GPO5	LD2	Output	LED
6	PH1	MFX_GPO6	unused	Output	-
10	PA0	MFX_GPO0	Touch screen X+	ADC in	LCD

Table 11. MFX signals (continued)

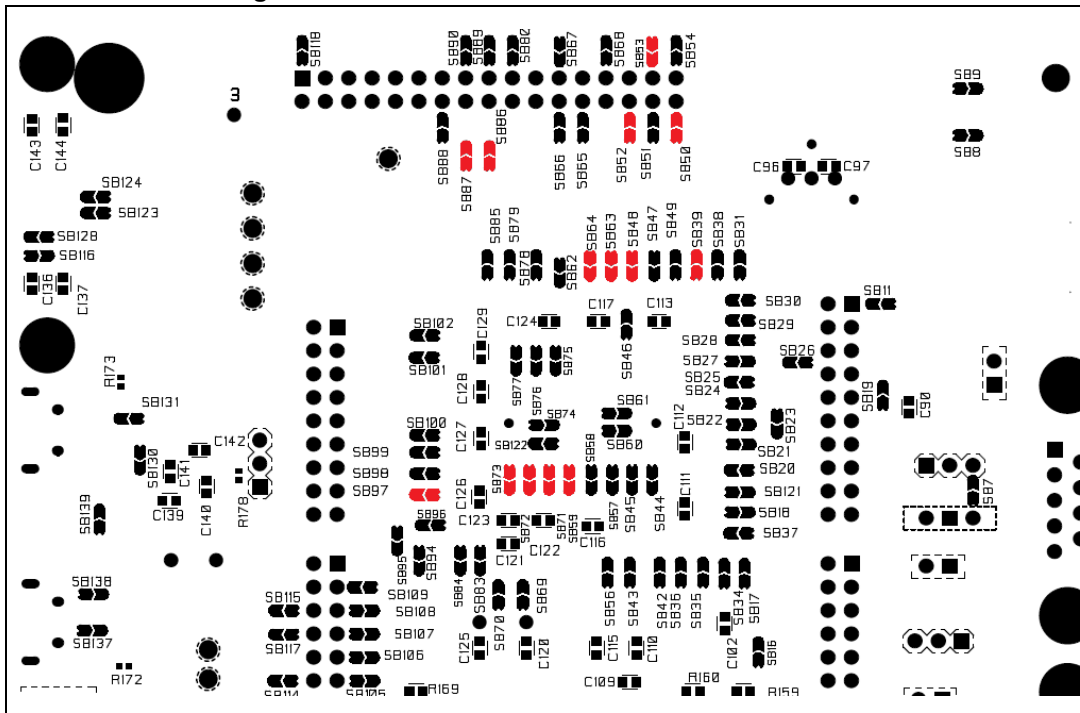
Pin number of MFX	Pin name of MFX	MFX functions	Function of STM32756G-EVAL	Direction (For MFX)	Terminal device
11	PA1	MFX_GPO1	Touch screen X-	ADC in	LCD
12	PA2	MFX_GPO2	Touch screen Y+	ADC in	LCD
13	PA3	MFX_GPO3	Touch screen Y-	ADC in	LCD
15	PA5	MFX_GPIO5	JOY_SEL	Input	Codec
16	PA6	MFX_GPIO6	OTG_FS_OverCurrent	Input	USB_FS
17	PA7	MFX_GPIO7	OTG_FS_PowerSwitchOn	Output	USB_FS
18	PB0	MFX_GPIO0	unused	-	-
19	PB1	MFX_GPIO1	JOY_RIGHT	Input	Joystick
20	PB2	MFX_GPIO2	JOY_LEFT	Input	Joystick
26	PB13	MFX_GPIO13	AUDIO_INT	Input	Audio Codec
27	PB14	MFX_GPIO14	unused	-	-
28	PB15	MFX_GPIO15	MicroSDcard Detect	Input	MicroSD
29	PA8	MFX_GPIO8	OTG_HS_OverCurrent	Input	USB_HS
30	PA9	MFX_GPIO9	EXT_RESET	Output	CN1 Extension connector
31	PA10	MFX_GPIO10	XSDN	Output	Camera
32	PA11	MFX_GPIO11	RSTI	Output	Camera
33	PA12	MFX_GPIO12	Camera_PLUG	Input	Camera
38	PA15	MFX_GPO7	LD4	Output	LED
39	PB3	MFX_GPIO3	JOY_DOWN	Input	Joystick
40	PB4	MFX_GPIO4	JOY_UP	Input	Joystick

2.18 Motor Control

STM32446E-EVAL evaluation board supports both asynchronous and synchronous three-phase brushless motor control via a 34 pins connector CN3, which provides all required control and feedback signals to and from motor power-driving board. The available signals on this connector are emergency stop, motor speed, 3 phase motor current, bus voltage, heatsink temperature, coming from the motor driving board and 6 channels of PWM control signal, going to the motor driving circuit.

Solder bridges that must be closed for motor control application, are marked in red and are showed in [Figure 7](#). The solder bridges, that must be opened for motor control application are: SB85, SB83, SB84, SB19, SB46, SB26, SB38, SB114, SB110 SB111, SB112 and they are showed in the same [Figure 7](#).

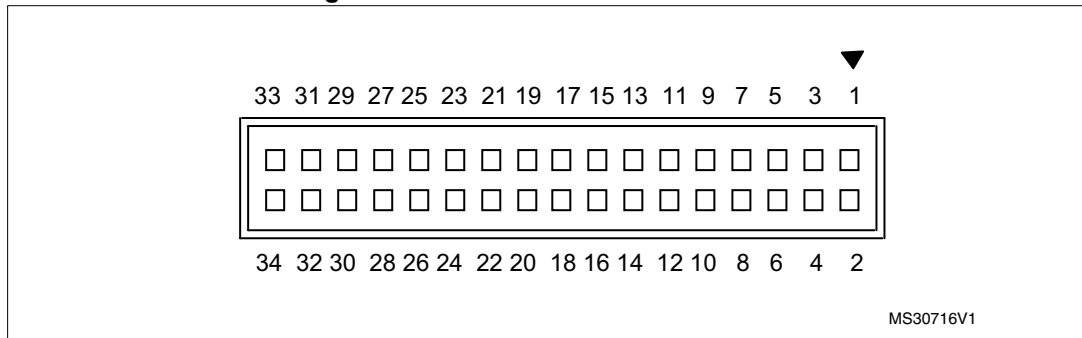
Figure 7. PCB underside rework for Motor Control



3 Connectors

3.1 Motor control connector CN3

Figure 8. Motor Control connector CN3



MS30716V1

Table 12. Motor Control connector CN13

Description	Pin of STM32F4x	Pin number of CN3	Solder bridge	Solder bridge	Pin number of CN3	Pin of STM32F4x	Description
Emergency STOP	PA6	1	-	-	2	-	GND
MC_UH	PC6	3	Close: SB64	-	4	-	GND
MC_UL	PA5	5	Close:SB97	-	6	-	GND
MC_VH	PC7	7	Close:SB63	-	8	-	GND
MC_VL	PB0	9	Close:SB98	-	10	-	GND
MC_WH	PC8	11	Close:SB48	-	12	-	GND
MC_WL	PB1	13	Close:SB99	Close:SB59	14	PC0	BUS VOLTAGE
CURRENT A	PA1	15	Close:SB87	-	16	-	GND
CURRENT B	PA2	17	Close:SB86	-	18	-	GND
CURRENT C	PA3	19	Close:SB74	-	20	-	GND
ICL Shut out	PG6	21	Close: SB62	-	22	-	GND
DISSIPATIVE BRAKE PWM	PD3	23	Close: SB67	Close:SB72	24	PC2	Inductor current
+5V power	-	25	-	Close:SB71	26	PC1	Heatsink temperature
PFC SYNC	PA8	27	Close:SB49	-	28	-	3.3 V power
PFC PWM	PA11	29	Close:SB39	Close:SB52	30	PB12	PFC Shut down

Table 12. Motor Control connector CN13 (continued)

Description	Pin of STM32F4x	Pin number of CN3	Solder bridge	Solder bridge	Pin number of CN3	Pin of STM32F4x	Description
Encoder A	PB6	31	Close:SB53	Close:SB73	32	PC3	PFC Vac
Encoder B	PB7	33	-	-	34	PB8	Encoder Index

Note: Some 0 Ohm resistors have to be removed or soldered to enable motor control application, except the solder bridges configurations mentioned above.

3.2 RF_Connectors CN6 and CN7

Table 13. Connector CN6

Pin number	Signal Name	Pin number	Signal Name
1	RF_INT1	11	RF_SAI1_FS_A
2	I2C4_SDA	12	RF_SAI1_MCLK_A
3	I2C4_SCL	13	GND
4	GND	14	+3V3
5	RF_SPI2_MOSI/2_SD	15	SDCARD_CMD
6	RF_SPI2_SCK/2_CK	16	SDCARD_CK
7	RF_SPI2_MISO	17	SDCARD_D3
8	RF_SPI2_CS	18	SDCARD_D2
9	RF_SAI1_SCK_A	19	SDCARD_D1
10	RF_SAI1_SD_A	20	SDCARD_D0

Table 14. Connector CN7

Pin number	Signal Name	Pin number	Signal Name
1	GND	10	RF_USART6_CTS
2	RF_INT2	11	RF_USART6_TX
3	RF_VDDA	12	RF_USART6_RX
4	GND	13	RF_USART6_CK
5	RF_ADCb_12_IN5	14	RF_USART6_RTS
6	RF_ADCa_123_IN3	15	GND

Table 14. Connector CN7 (continued)

Pin number	Signal Name	Pin number	Signal Name
7	RF_TIM2_CH1/2_ETR	16	RF_SAI1_SD_B
8	RF_TIM2_CH2	17	+5V
9	RESET#	18	+3V3

3.3 FMC_Connectors CN11 and CN12

Table 15. FMC Connectors CN11

Pin number	Pin Name	Signal Name
1	GND	GND
2	+3V3	+3V3
3	PD14	FMC_D0
4	PD15	FMC_D1
5	PF4	FMC_D2
6	PD1	FMC_D3
7	GND	GND
8	GND	GND
9	PE7	FMC_D4
10	PE8	FMC_D5
11	PE9	FMC_D6
12	PE10	FMC_D7
13	PG6	QSPI_BK1_NCS
14	PF6	QSPI_BK1_IO3
15	PF9	QSPI_BK1_IO1
16	PD3	QSPI_CLK
17	PF7	QSPI_BK1_IO2
18	PF8	QSPI_BK1_IO0
19	PA7	FMC_SDNWE
20	PE0	FMC_NBL0
21	PF11	FMC_SDNRAS
22	PG15	FMC_SDNCAS
23	PG4	FMC_BA0
24	PC4	FMC_SDNE0
25	PG0	FMC_A10
26	PG5	FMC_BA1

Table 15. FMC Connectors CN11 (continued)

Pin number	Pin Name	Signal Name
27	PF1	FMC_A1
28	PF0	FMC_A0
29	PF3	FMC_A3
30	PF2	FMC_A2
31	GND	GND
32	+5V	+5V

Table 16. FMC Connectors CN12

Pin number	Pin Name	Signal Name
1	GND	GND
2	+3V3	+3V3
3	GND	GND
4	PD5	FMC_NWE
5	GND	GND
6	PD4	FMC_NOE
7	D5V	D5V
8	GND	GND
9	PD9	FMC_D14
10	PD10	FMC_D15
11	PE15	FMC_D12
12	PD8	FMC_D13
13	PE13	FMC_D10
14	PE14	FMC_D11
15	PE11	FMC_D8
16	PE12	FMC_D9
17	GND	GND
18	GND	GND
19	PE1	FMC_NBL1
20	PD7	FMC_NE1
21	PC5	FMC_SDCKE0
22	PG8	FMC_SDCLK
23	PG1	FMC_A11

Table 16. FMC Connectors CN12 (continued)

Pin number	Pin Name	Signal Name
24	PG2	FMC_A12
25	PF15	FMC_A9
26	PF14	FMC_A8
27	PF13	FMC_A7
28	PF12	FMC_A6
29	PF5	FMC_A5
30	PF4	FMC_A4
31	GND	GND
32	+5V	+5V

3.4 Daughterboard connector CN13 and CN10

Table 17. DB_Connectors CN13

Pin number	Signal Name	Pin number	Signal Name
1	GND	17	PC2
2	+3V3	18	PB1
3	PC13_ANTI_TAMP	19	VBAT
4	PA2	20	PB10
5	PC14_OSC32_IN	21	+5V
6	PA3	22	E5V
7	PC15_OSC32_OUT	23	GND
8	PA4	24	PB11
9	PH0_OSC_IN	25	PC3
10	PA6	26	PB12
11	PH1_OSC_OUT	27	PAO_WKUP
12	PA5	28	PB13
13	NRST	29	PA1
14	GND	30	PD11
15	PC0	31	+3V3
16	PB0	32	GND

Table 18. DB_Connectors CN10

Pin number	Signal Name	Pin number	Signal Name
1	D5V	17	PA11
2	+3V3	18	PB9
3	PD12	19	PA12
4	GND	20	GND
5	PD13	21	PA13
6	PB4	22	PC1
7	PG3	23	PA14
8	PB5	24	NC
9	PC6	25	PA15
10	PB7	26	PG11
11	P	27	PG9
12	BOOT0	28	PB3
13	PA10	29	PG10
14	NC	30	NC
15	GND	31	GND
16	PB8	32	+3V3

3.5 MicroSD connector CN4

Figure 9. MicroSD connector CN4 (front view)

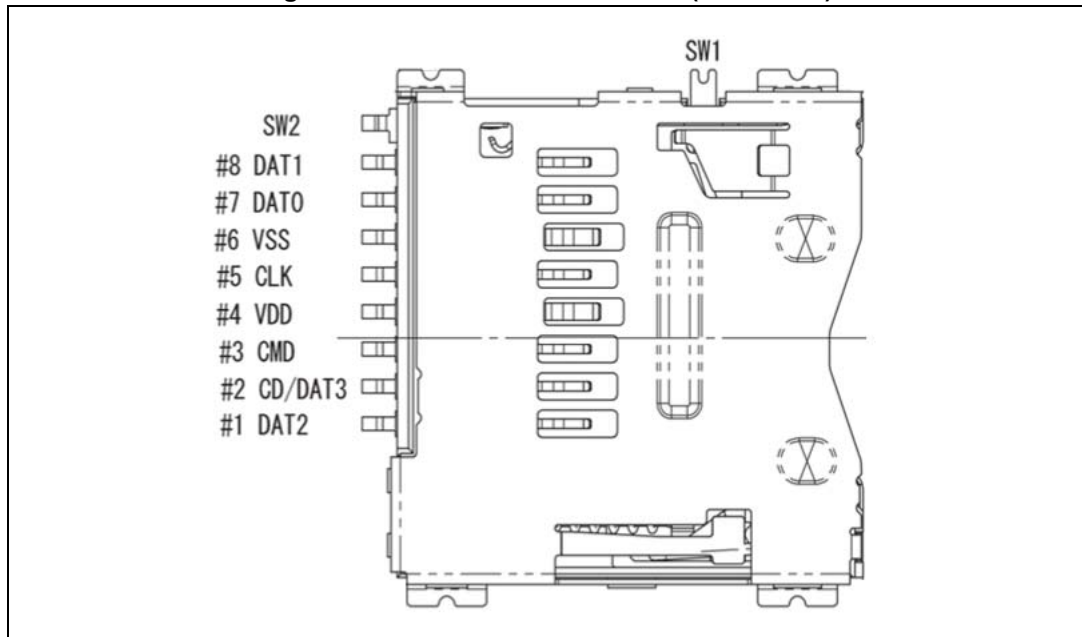


Table 19. MicroSD connector CN4

Pin number	Description	Pin number	Description
1	SDCARD_D2(PC10)	5	SDCARD_CK (PC12)
2	SDCARD_D3(PC11)	6	VSS/GND
3	SDCARD_CMD(PD2)	7	SDCARD_D0(PC8)
4	+3V3	8	SDCARD_D1(PC9)
-	-	10	SDCARD_detect (mfx_io15)

3.6 RS232 connector CN25

Figure 10. RS232 connector CN25 (front view)

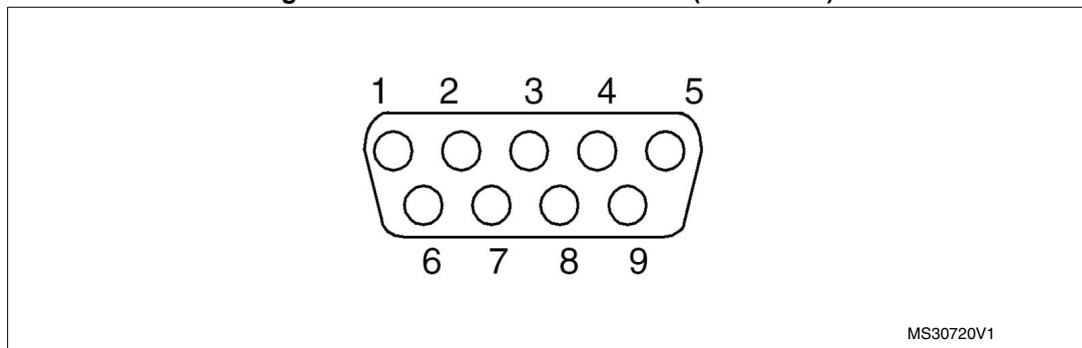


Table 20. RS232 connector CN25

Pin number	Description	Pin number	Description
1	NC	6	RS232_DSR
2	RS232_RX	7	NC
3	RS232_TX	8	RS232_CTS
4	NC	9	NC
5	GND	-	-

3.7 ST-LINK/V2-1 USB Type B connector CN16

The USB connector CN16 is used to connect embedded ST-LINK/V2-1 to PC for debugging of board.

Figure 11. USB type B connector CN16

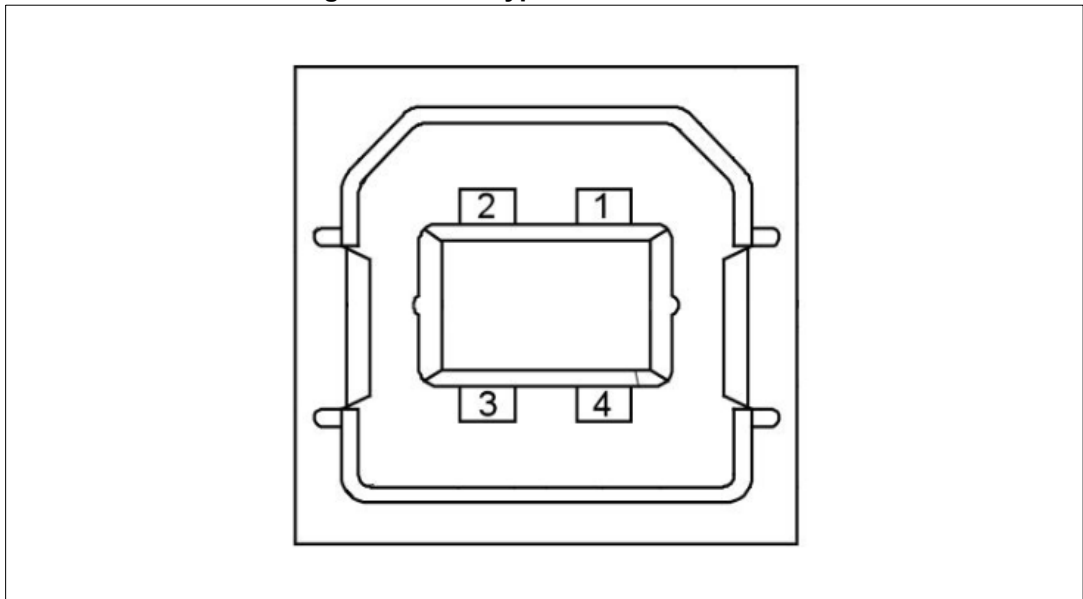


Table 21. USB type B connector CN16

Pin number	Description	Pin number	Description
1	VBUS_STLINK (power)	4	GND
2	STL_USB_DM	5,6	Shield
3	STL_USB_DP	-	-

3.8 Audio jack CN22 and CN23

A 3.5mm Stereo audio jack CN22 and CN23 are connected to audio DAC and ADC is available on STM32446E-EVAL board.

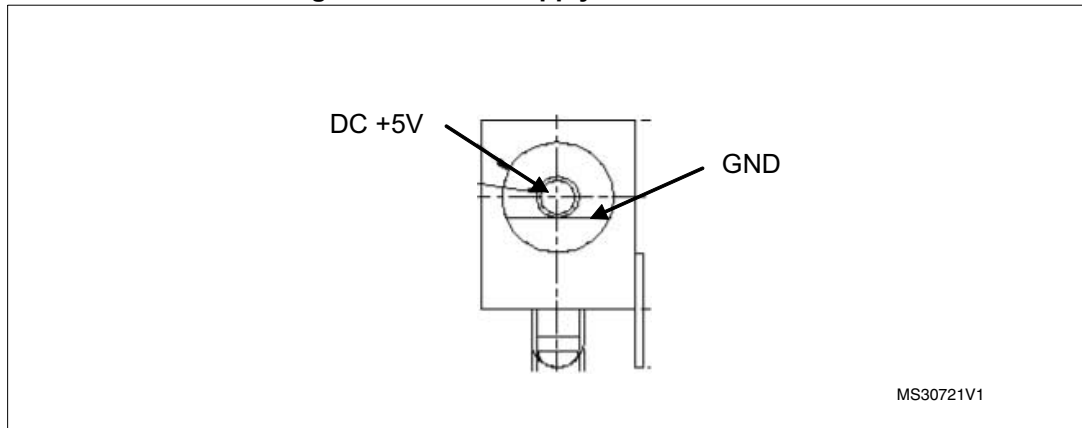
3.9 ST-LINK/V2-1 programming connector CN18

The connector CN18 is used only for embedded ST-LINK/V2-1 programming during board manufacturing. It is not populated by default and not for end user.

3.10 Power connector CN20

STM32446E-EVAL evaluation board can be powered from a DC 5V power supply via the external power supply jack (CN20) shown in [Figure 10: RS232 connector CN25 \(front view\)](#). The central pin of CN20 must be positive.

Figure 12. Power supply connector CN20



3.11 Analog input connector CN21

Figure 13. Analog input-output connector CN21

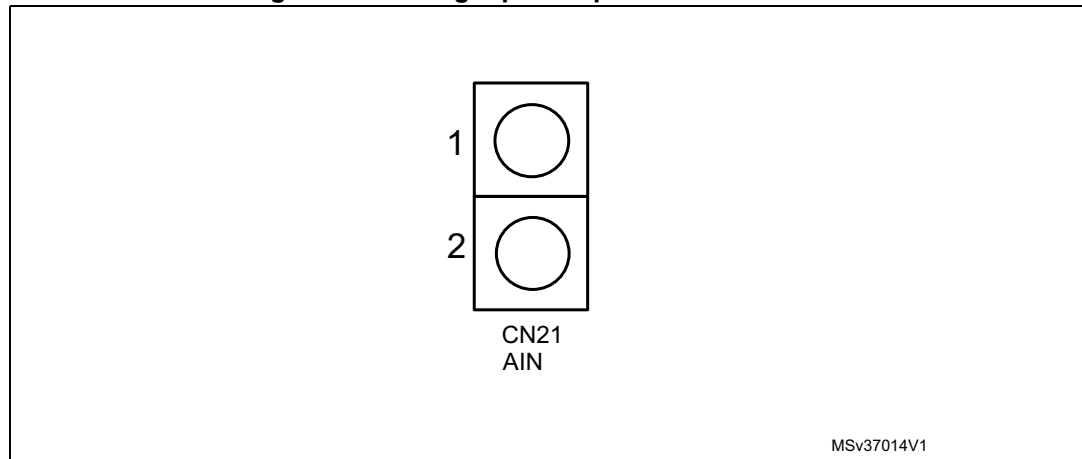


Table 22. Analog input-output connector CN4

Pin number	Description	Pin number	Description
1	GND	2	Analog input-output PA4

Appendix A STM32446E-EVAL IO assignment

Table 23. IOs assignment

LQFP144	Pin Name	Default configuration	Motor control configuration	Camera config
1	PE2	RF_SAI1_MCLK_A TRACECLK	-	-
2	PE3	RF_SAI1_SD_B TRACED0	-	-
3	PE4	RF_SAI1_FS_A TRACED1	-	-
4	PE5	RF_SAI1_SCK_A TRACED2	-	-
5	PE6	RF_SAI1_SD_A TRACED3	-	-
6	VBAT	-	-	-
7	PC13- ANTI_TAMP	Key TAMP_1 WKUP1	-	-
8	PC14- OSC32_IN	-	-	-
9	PC15- OSC32_OUT	-	-	-
10	PF0	FMC_A0	-	-
11	PF1	FMC_A1	-	-
12	PF2	FMC_A2	-	-
13	PF3	FMC_A3	-	-
14	PF4	FMC_A4	-	-
15	PF5	FMC_A5	-	-
16	VSS_5	-	-	-
17	VDD_5	-	-	-
18	PF6	QSPI_BK1_IO3	-	-
19	PF7	QSPI_BK1_IO2	-	-
20	PF8	QSPI_BK1_IO0	-	-
21	PF9	QSPI_BK1_IO1	-	-
22	PF10	RF_SPI2_CS	-	-
23	PH0 - OSC_IN	-	-	-
24	PH1 - OSC_OUT	-	-	-

Table 23. IOs assignment (continued)

LQFP144	Pin Name	Default configuration	Motor control configuration	Camera config
25	NRST	-	-	-
26	PC0	ULPI_STP	Bus_Voltage_ADC123_IN10	-
27	PC1	Mems_SPI3_MOSI	Heatsink_Temperature_ADC123_IN12	-
28	PC2	ULPI_DIR	PFC_IndCurr_ADC123_IN12	-
29	PC3	ULPI_NXT	PFC_Vac_ADC123_IN13	-
30	VDD_12	-	-	-
31	VSSA	-	-	-
32	VREF+	-	-	-
33	VDDA	-	-	-
34	PA0-WKUP	MFx_IRQ_OUT	-	-
35	PA1	SAI2_MCLK_B	Current_ADC123_IN1	-
36	PA2	SAI2_SCK_B	Current_ADC123_IN2	-
37	PA3	ULPI_D0 RF_ADCa_123_IN3	Current_ADC123_IN3	-
38	VSS_4	-	-	-
39	VDD_4	-	-	-
40	PA4	ADC12_IN4	-	HSYNC
41	PA5	ULPI_CK RF_ADCb_12_IN5	UL_TIM8_CH1N	
42	PA6	-	STOP_TIM8_BKIN	PIXCLK
43	PA7	FMC_SDNWE	-	-
44	PC4	FMC_SDNE0	-	-
45	PC5	FMC_SDCKE0	-	-
46	PB0	ULPI_D1	VL_TIM8_CH2N	-
47	PB1	ULPI_D2	WL_TIM8_CH3N	-
48	PB2 / BOOT1	BOOT1 ULPI_D4	-	-
49	PF11	FMC_SDNRAS	-	-
50	PF12	FMC_A6	-	-
51	VSS_6	-	-	-

Table 23. IOs assignment (continued)

LQFP144	Pin Name	Default configuration	Motor control configuration	Camera config
52	VDD_6	-	-	-
53	PF13	FMC_A7	-	-
54	PF14	FMC_A8	-	-
55	PF15	FMC_A9	-	-
56	PG0	FMC_A10	-	-
57	PG1	FMC_A11	-	-
58	PE7	FMC_D4	-	-
59	PE8	FMC_D5	-	-
60	PE9	FMC_D6	-	-
61	VSS_7		-	-
62	VDD_7		-	-
63	PE10	FMC_D7	-	-
64	PE11	FMC_D8	-	-
65	PE12	FMC_D9	-	-
66	PE13	FMC_D10	-	-
67	PE14	FMC_D11	-	-
68	PE15	FMC_D12	-	-
69	PB10	ULPI_D3	-	-
70	PB11	LD1	-	-
71	VCAP1	-	-	-
72	VDD_1	-	-	-
73	PB12	ULPI_D5	PFC_Shutdown_TIM1_BKIN	-
74	PB13	ULPI_D6	-	-
75	PB14	RF_SPI2_MISO	-	-
76	PB15	RF_SPI2_MOSI	-	-
77	PD8	FMC_D13	-	-
78	PD9	FMC_D14	-	-
79	PD10	FMC_D15	-	-
80	PD11	SAI_2_SD_A	-	-
81	PD12	I2C4_SCL	-	-
82	PD13	I2C4_SDA	-	-

Table 23. IOs assignment (continued)

LQFP144	Pin Name	Default configuration	Motor control configuration	Camera config
83	VSS_8	-	-	-
84	VDD_8	-	-	-
85	PD14	FMC_D0	-	-
86	PD15	FMC_D1	-	-
87	PG2	FMC_A12	-	-
88	PG3	MFX_WAKEUP	-	-
89	PG4	FMC_BA0	-	-
90	PG5	FMC_BA1	-	-
91	PG6	QSPI_BK1_NCS	ICL_shutout_GPIO	-
92	PG7	RF_USART6_CK	-	-
93	PG8	FMC_SDCLK	-	-
94	VSS_9	-	-	-
95	VDD_1_USB33	-	-	-
96	PC6	-	UH_TIM8_CH1	D0
97	PC7	RF_USART6_RX	VH_TIM8_CH2	D1
98	PC8	SDCARD_D0	WH_TIM8_CH3	D2
99	PC9	SDCARD_D1	-	D3
100	PA8	RF_INT1	PFC_Sync_TIM1_CH1	-
101	PA9	USB_FS_VBUS USART1_TX RF_SPI2_SCK	-	-
102	PA10	USB_FS_ID USART1_RX	-	-
103	PA11	USB_FS_DM	PFC_PWM_TIM1_CH4	-
104	PA12	USB_FS_DP	-	-
105	PA13	JTMS-SWDIO	-	-
106	VCAP2	-	-	-
107	VSS_2	-	-	-
108	VDD_2	-	-	-
109	PA14	JTCK-SWCLK	-	-
110	PA15	JTDI	-	-
111	PC10	SDCARD_D2	-	D8

Table 23. IOs assignment (continued)

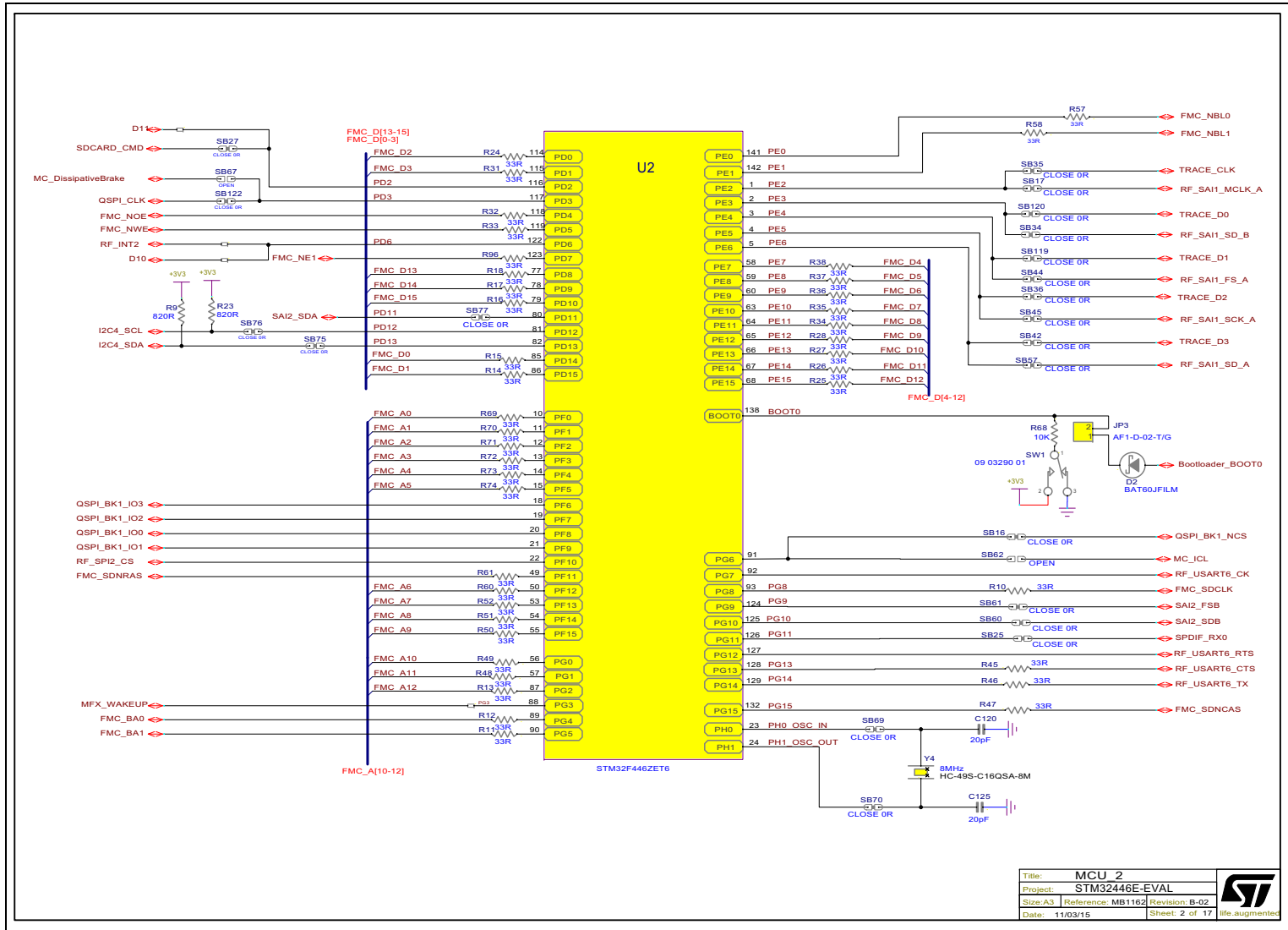
LQFP144	Pin Name	Default configuration	Motor control configuration	Camera config
112	PC11	SDCARD_D3	-	D4
113	PC12	SDCARD_CK	-	D9
114	PD0	FMC_D2	-	-
115	PD1	FMC_D3	-	-
116	PD2	SDCARD_CMD	-	D11
117	PD3	QSPI_CLK	Dissipative_brake_GPIO	D5
118	PD4	FMC_NOE	-	-
119	PD5	FMC_NWE	-	-
120	VSS_10	-	-	-
121	VDD_10	-	-	-
122	PD6	RF_INT2	-	D10
123	PD7	FMC_NE1 (CS_LCD)	-	-
124	PG9	SAI_2_FS_B	-	-
125	PG10	SAI_2_SD_B	-	-
126	PG11	SPDIF_RX0	-	-
127	PG12	RF_USART6_RTS	-	-
128	PG13	RF_USART6_CTS	-	-
129	PG14	RF_USART6_TX	-	-
130	VSS_11	-	-	-
131	VDD_11	-	-	-
132	PG15	FMC_SDNCAS	-	-
133	PB3	Mems_SPI3_SCK/3_CK JTDO/TRACESWO	-	-
134	PB4	LD3_NJTRST	-	-
135	PB5	ULPI_D7	-	-
136	PB6	MIC_I2S_TIM4_CH1	EncA_TIM4_CH1	-
137	PB7	MIC_I2S_TIM4_CH2	EncA_TIM4_CH2	VSYNC
138	BOOT0	-	-	-
139	PB8	CAN_1_RX RF_TIM2_CH1	EnclIndex_TIM4_CH3	D6
140	PB9	CAN_1_TX RF_TIM2_CH2	-	D7

Table 23. IOs assignment (continued)

LQFP144	Pin Name	Default configuration	Motor control configuration	Camera config
141	PE0	FMC_NBL0	-	-
142	PE1	FMC_NBL1	-	-
143	PDR_ON	-	-	-
144	VDD_3	-	-	-

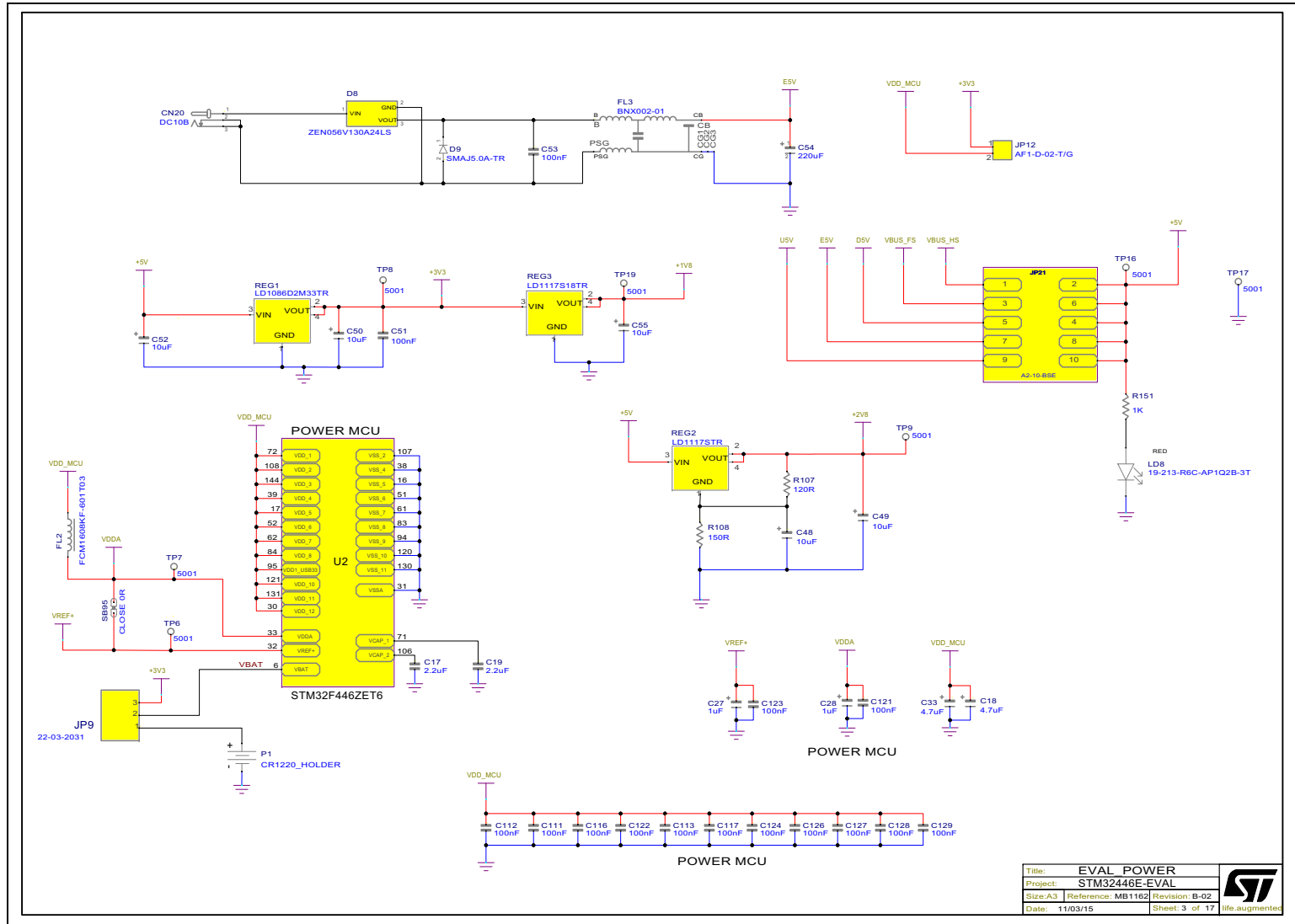


Figure 15. MCU 2



Title:	MCU 2		
Project:	STM32446E-EVAL		
Size:A3	Reference: MB1162		Revision: B-02
Date:	11/03/15		Sheet: 2 of 17

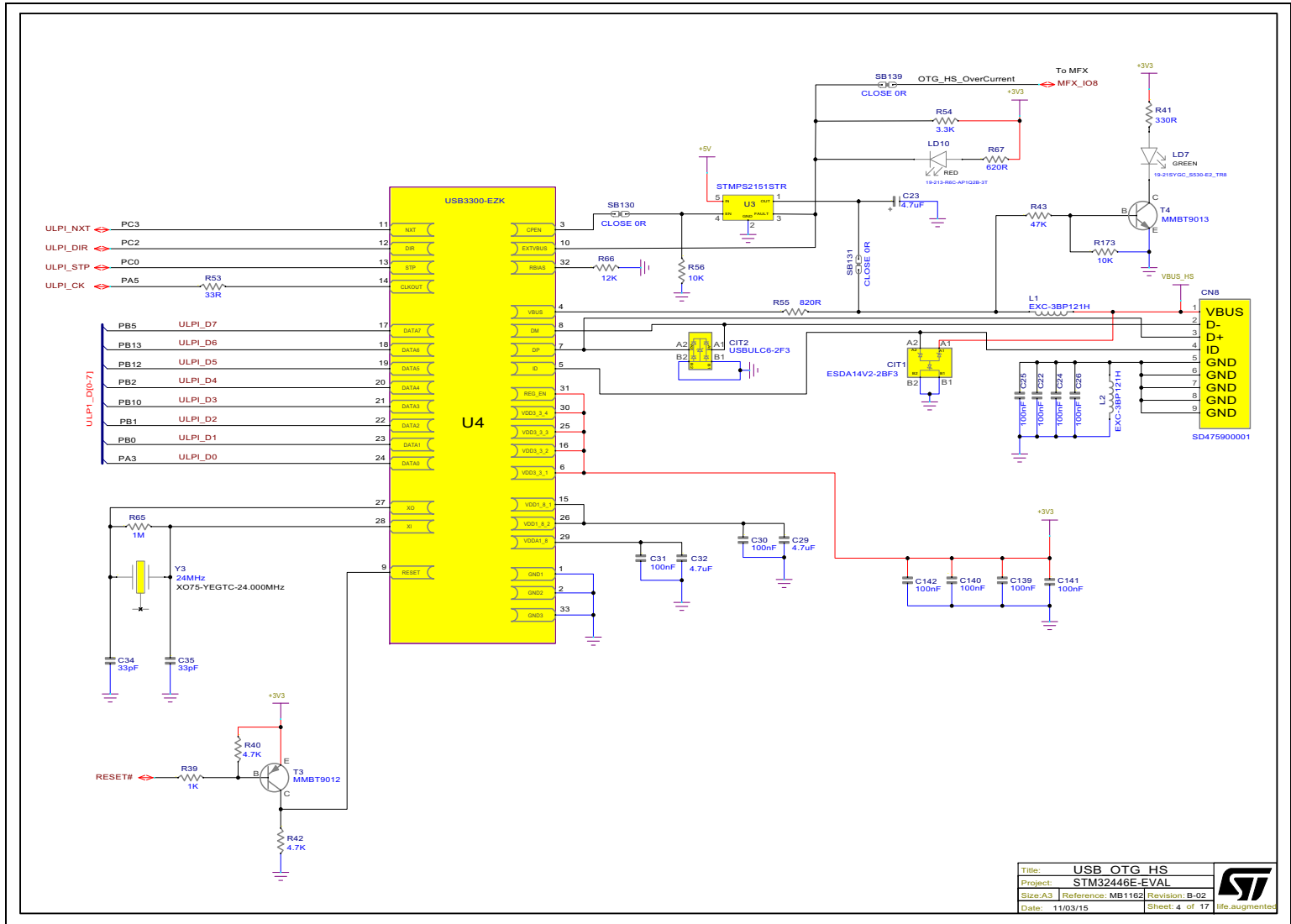
Figure 16. Power



Title:	EVAL_POWER	
Project:	STM32446E-EVAL	
Size:A3	Reference: MB1162	Revision: B-02
Date:	11/03/15	Sheet: 3 of 17



Figure 17. USB OTG HS



Title:	USB OTG HS	
Project:	STM32446E-EVAL	
Size/A3:	Reference: MB1162 Revision: B-02	
Date:	11/03/15 Sheet 4 of 17 life.augmented	

Figure 18. USB OTG FS

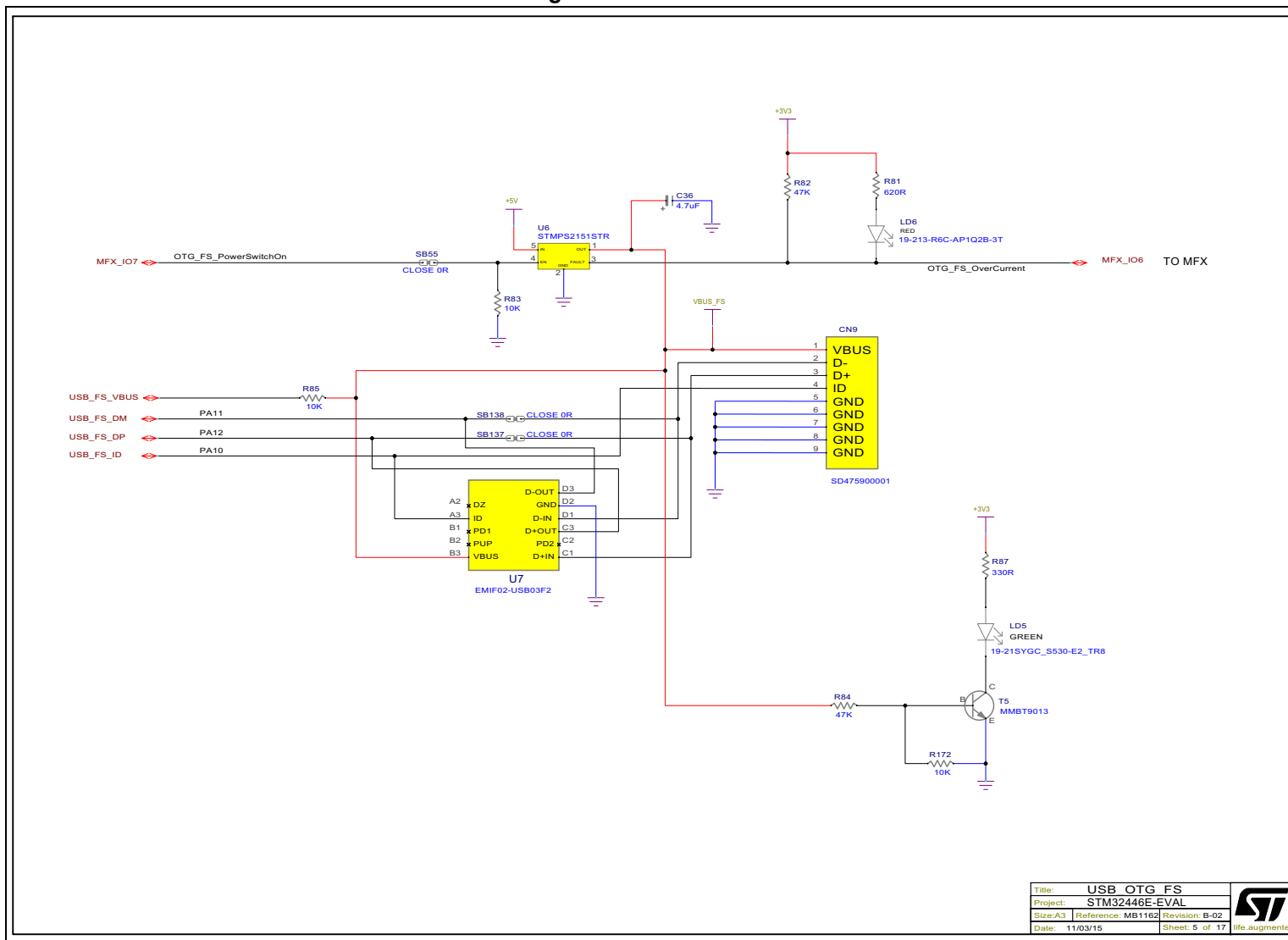
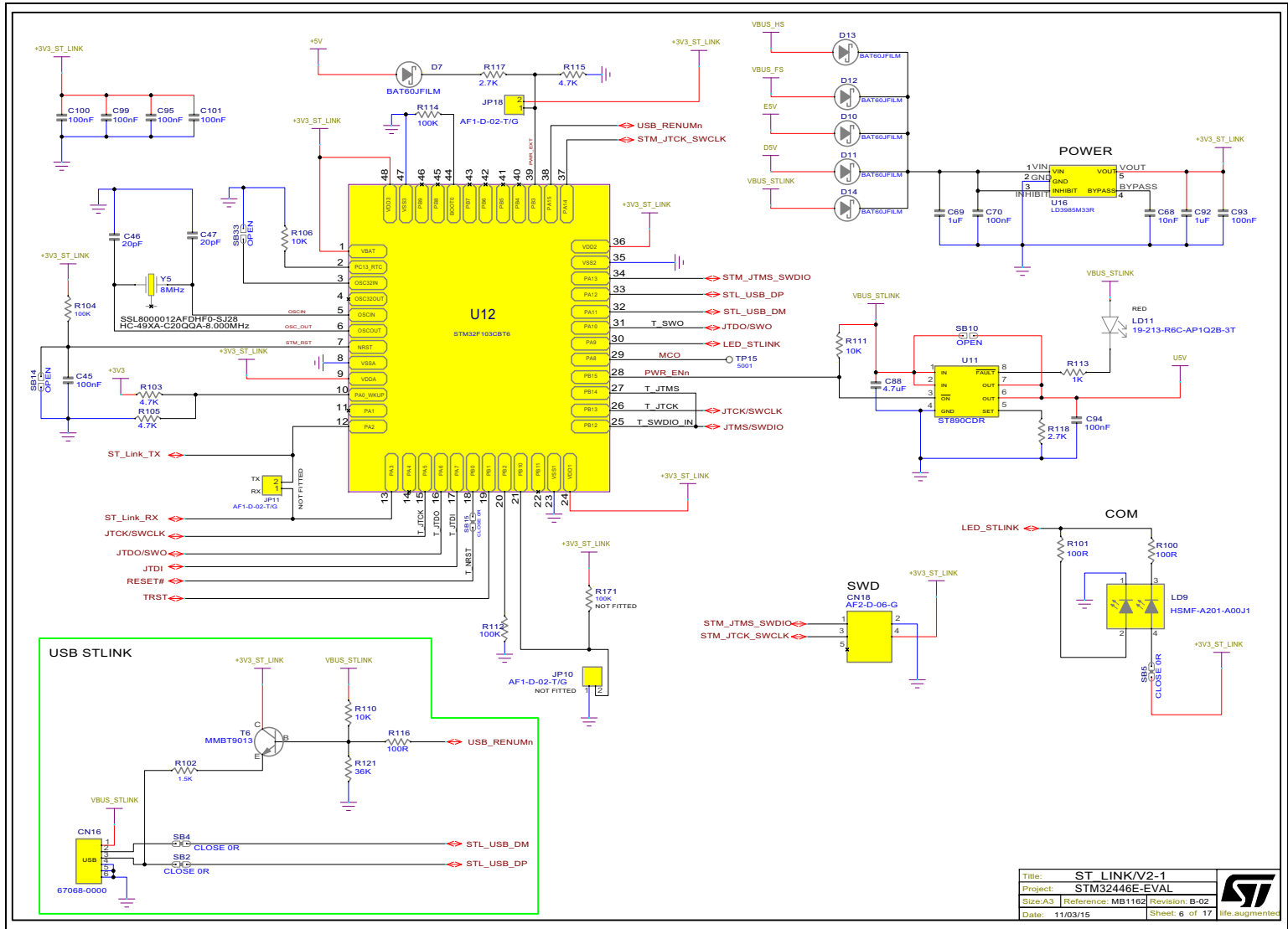


Figure 19. ST-LINK/V2-1



Title:	ST LINK/V2-1
Project:	STM32446E-EVAL
Size:	A3 Reference: MB1162 Revision: B-02
Date:	11/03/15 Sheet: 6 of 17 life.augmented



Figure 20. MFX V3

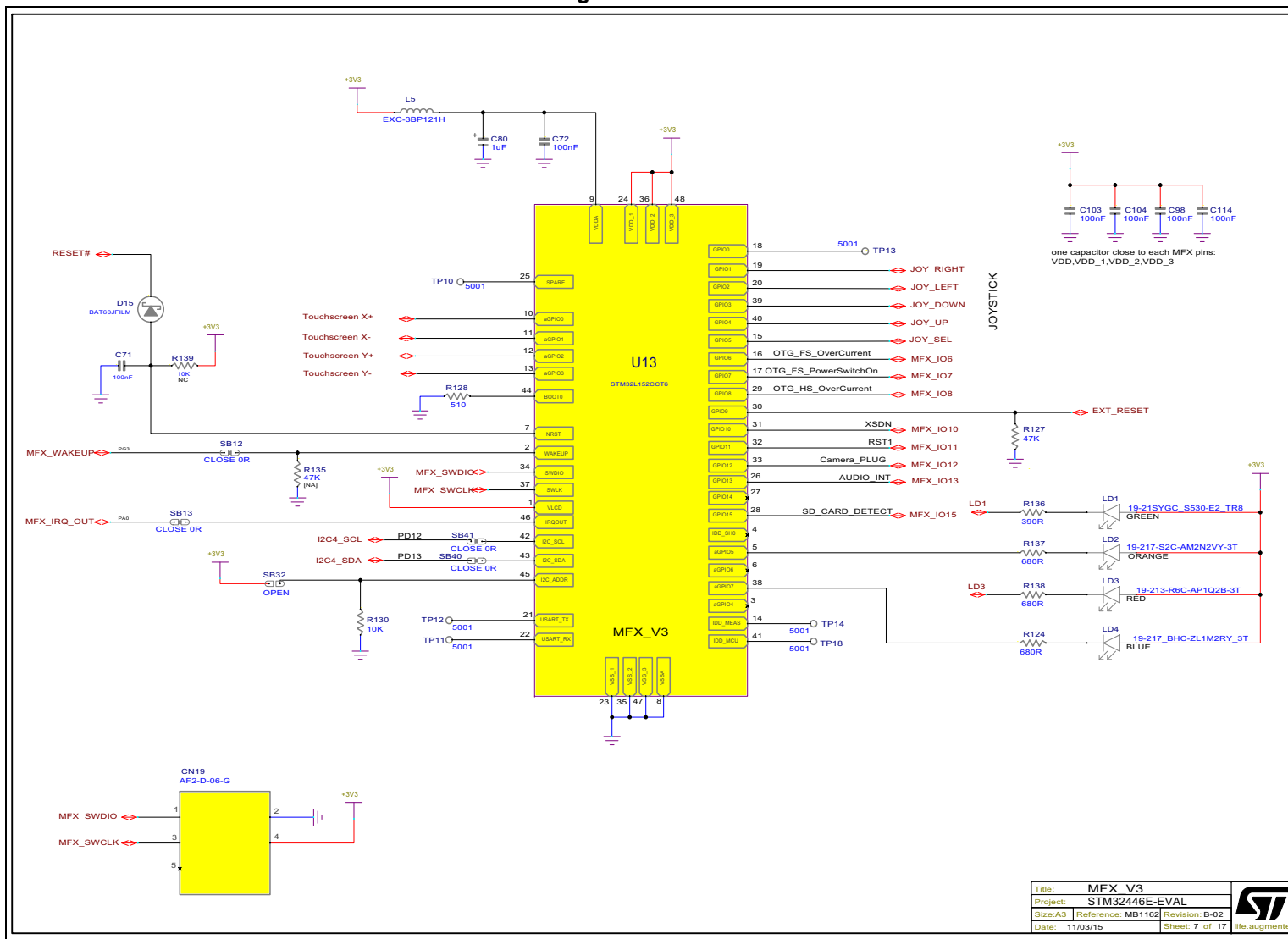
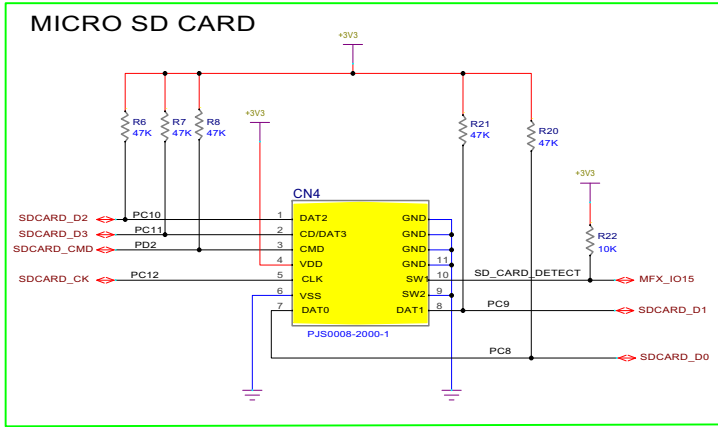
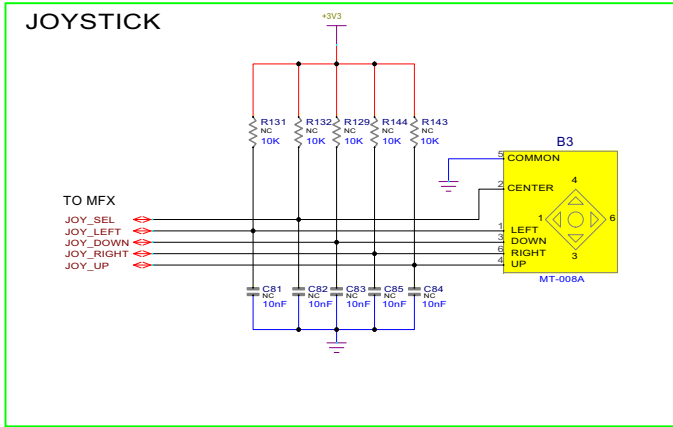
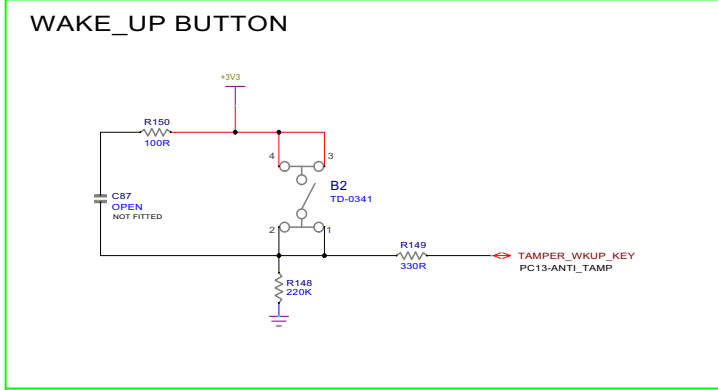
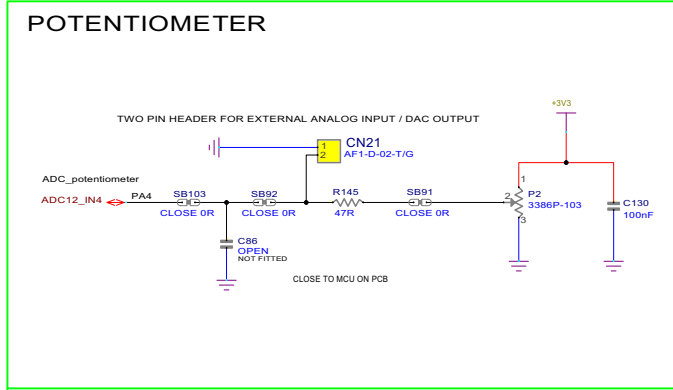




Figure 21. Peripherals



Title:	PERIPHERALS
Project:	STM32446E-EVAL
Size:	A3
Reference:	MB1162
Revision:	B-02
Date:	11/03/15
Sheet:	8 of 17



Figure 22. CAN, RS232 / IrDA

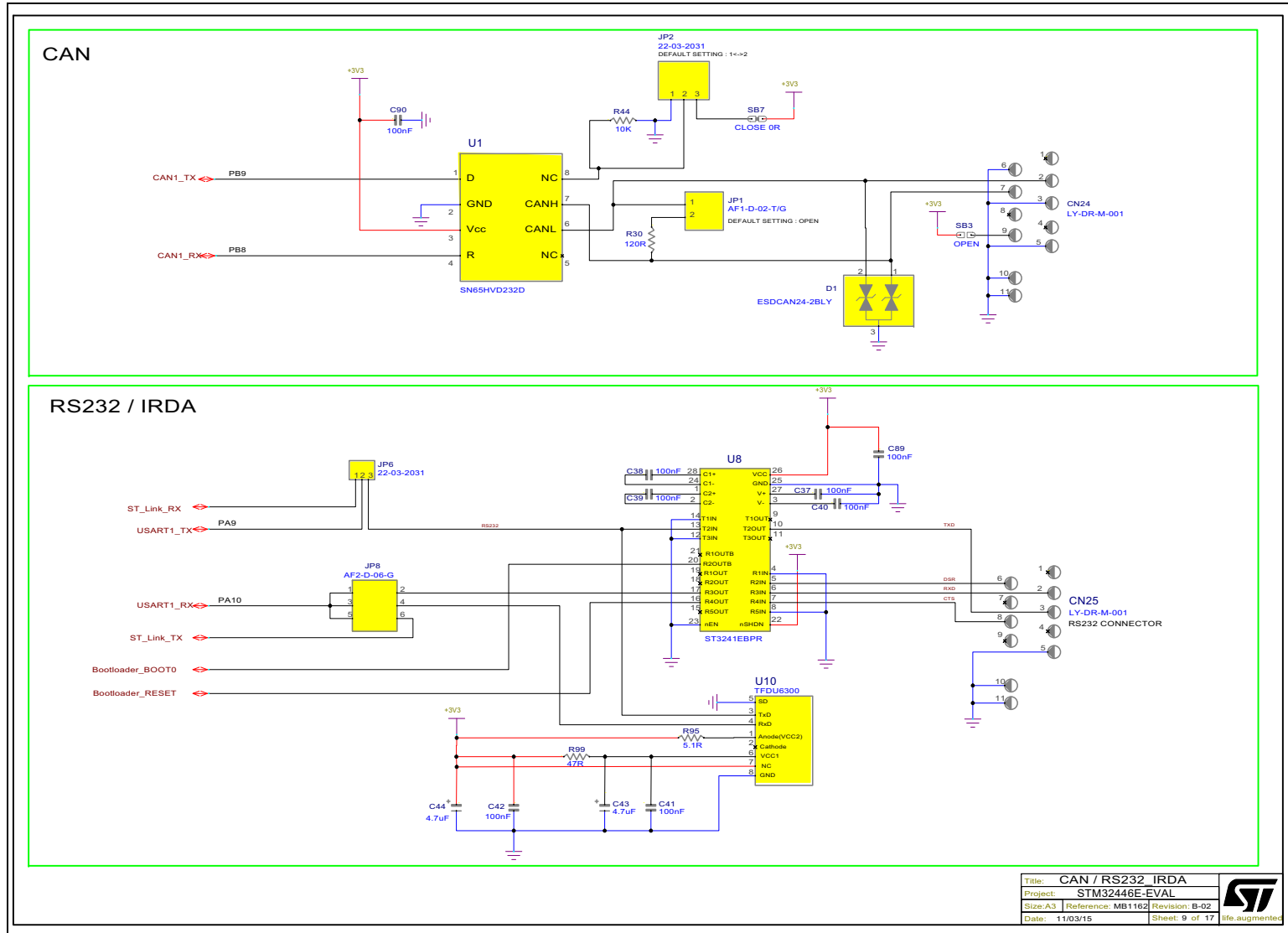
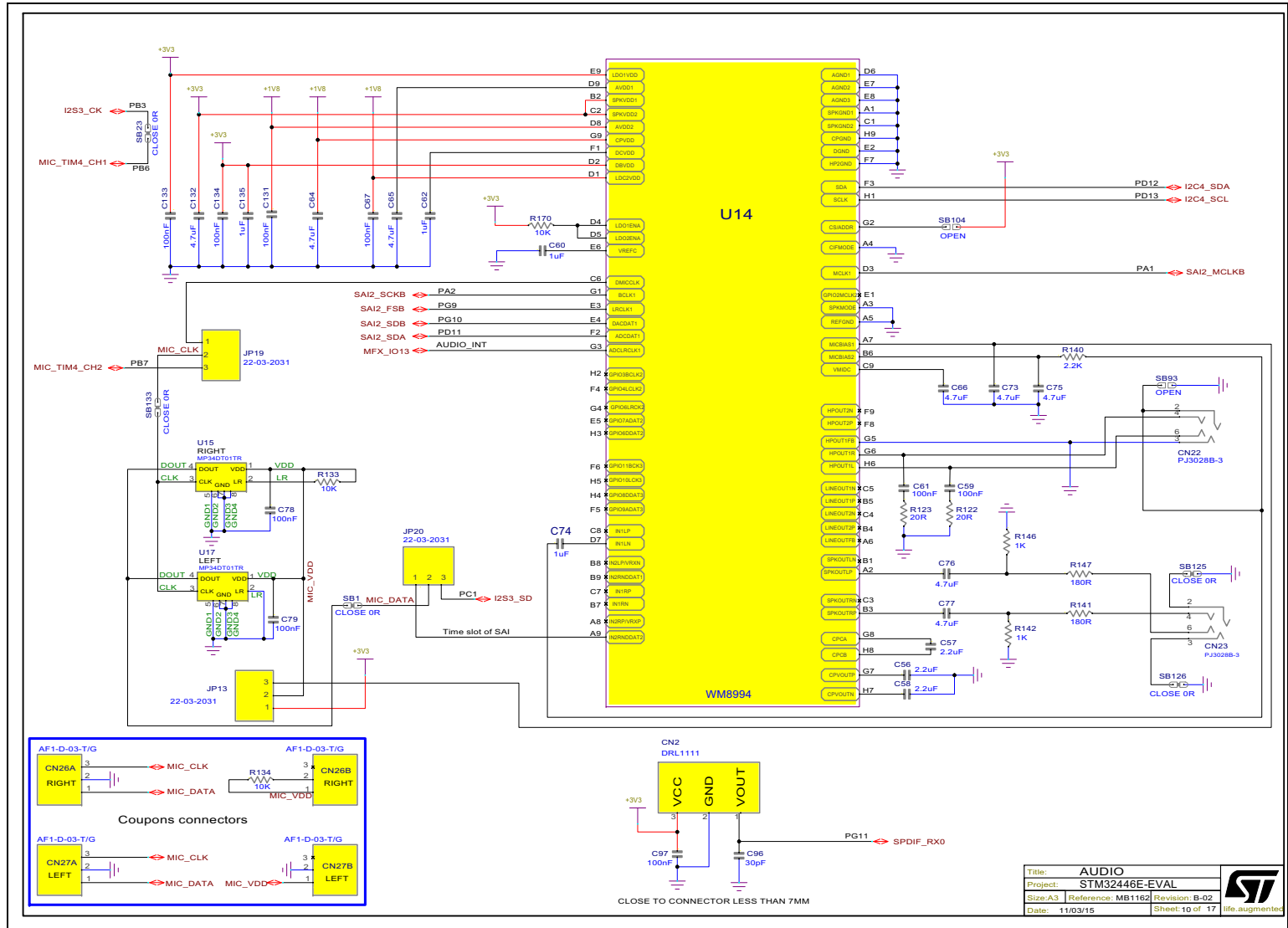




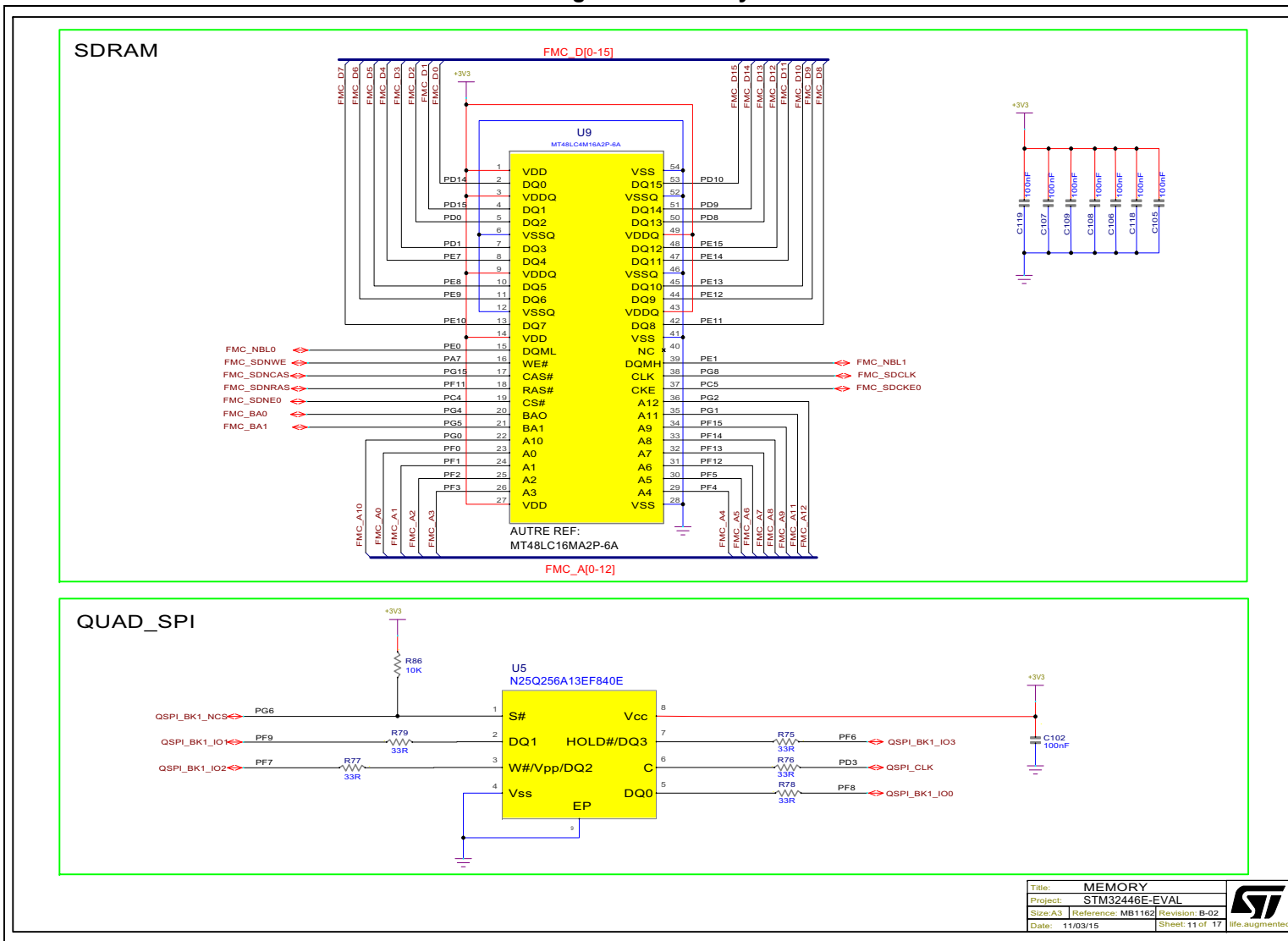
Figure 23. Audio



Title:	AUDIO
Project:	STM32446E-EVAL
Size: A3	Reference: MB1162
Date:	11/03/15
Revision:	B-02
Sheet:	10 of 17
File:	life.augmented



Figure 24. Memory

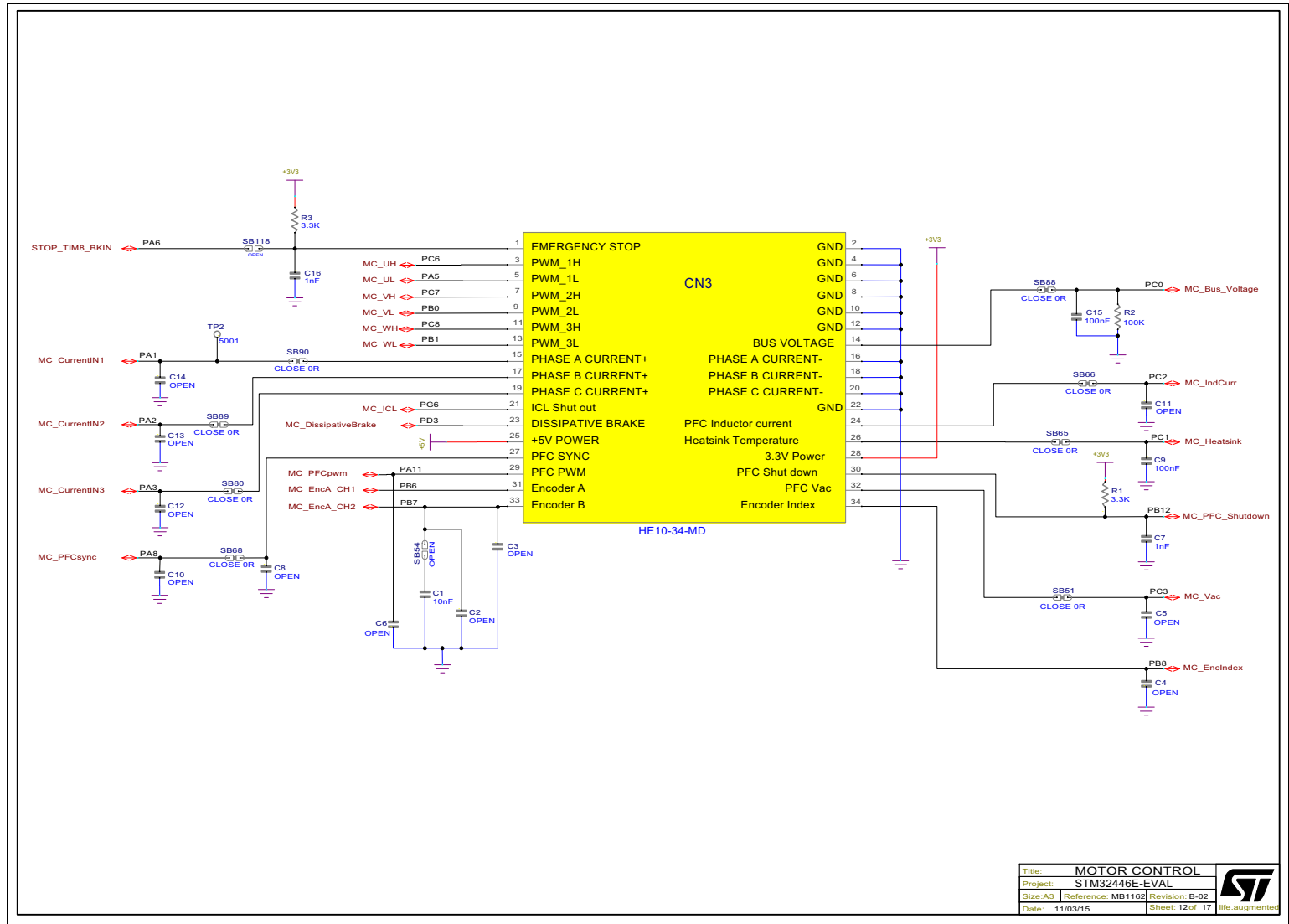


Title:	MEMORY
Project:	STM3246E-EVAL
Size: A3	Reference: MB1162
Date:	11/03/15
Revision:	B-02
Sheet:	11 of 17





Figure 25. Motor Control



Title: MOTOR CONTROL			
Project: STM32446E-EVAL			
Size: A3	Reference: MB1162		Revision: B-02
Date: 11/03/15			Sheet: 12 of 17

Figure 26. STM32446E-EVAL LCD

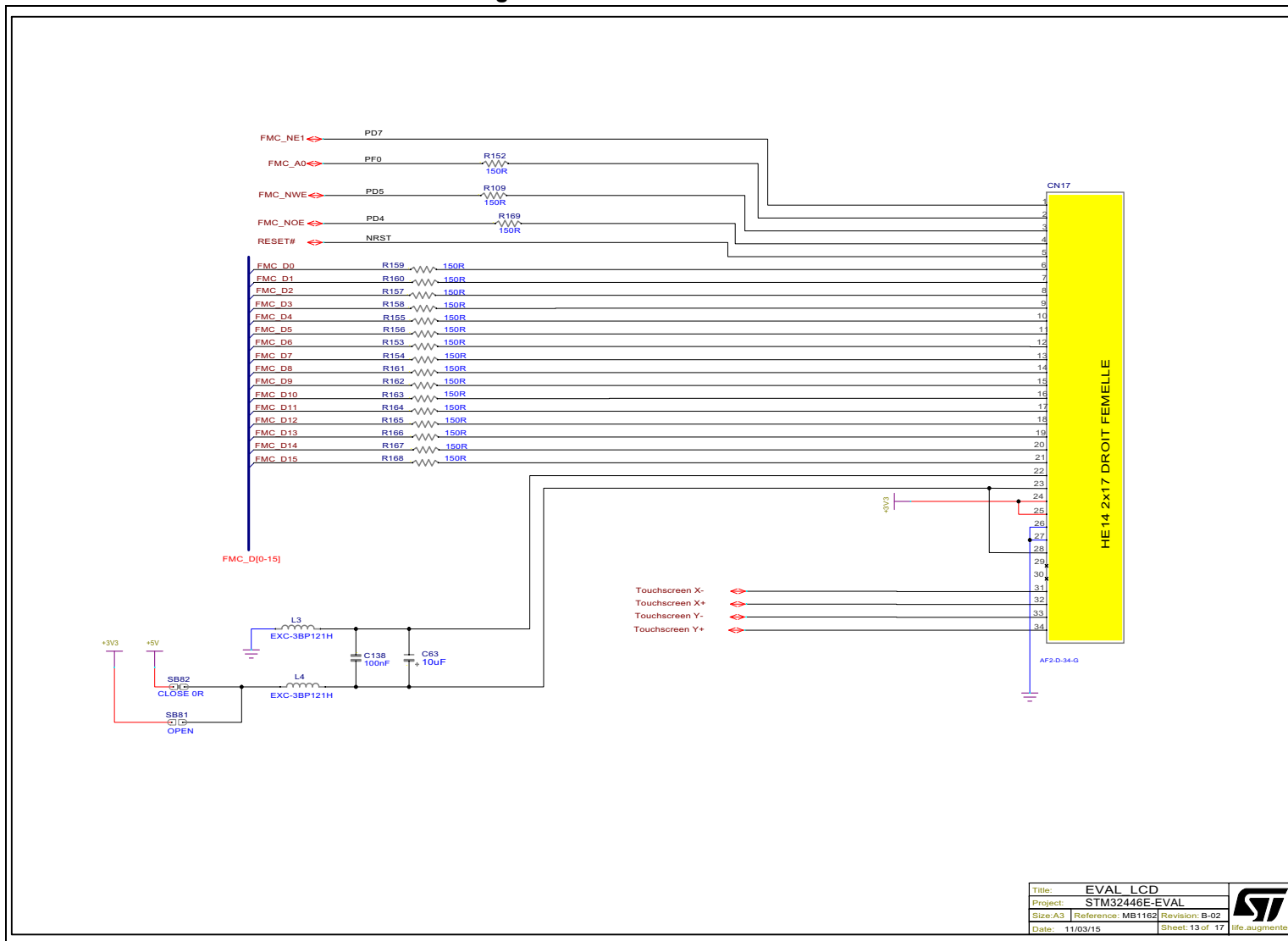


Figure 27. JTAG and trace

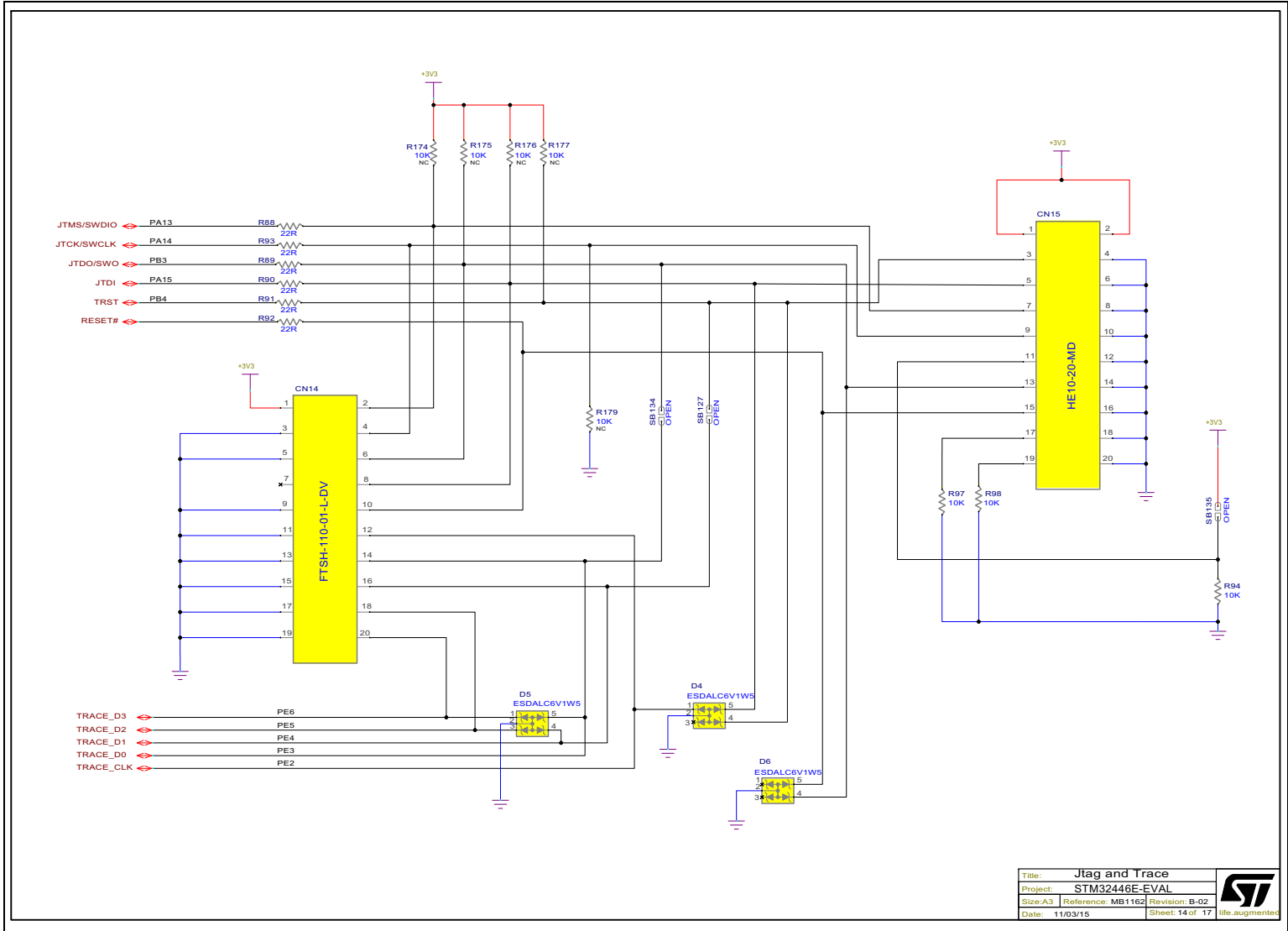


Figure 28. Camera connector

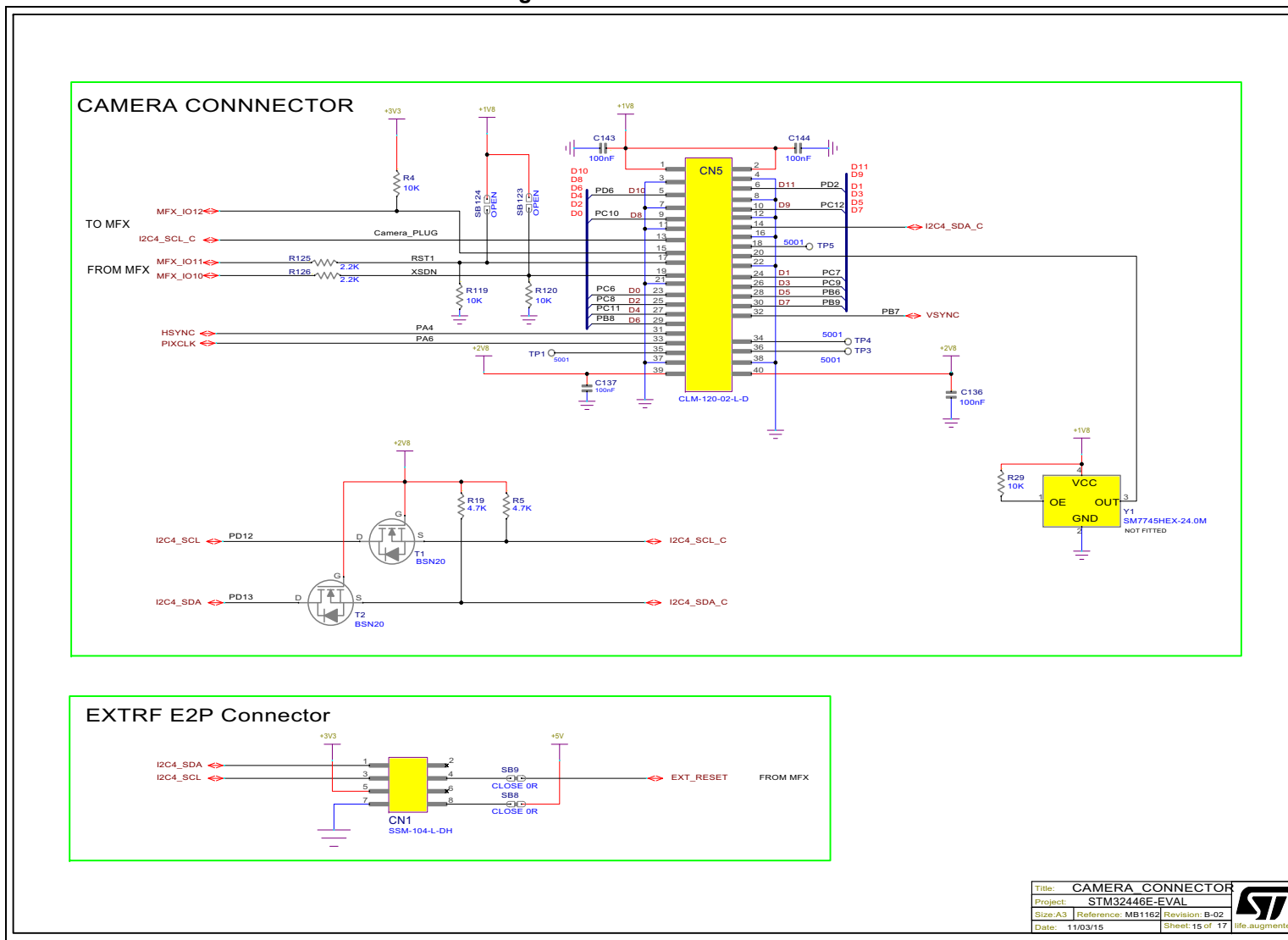
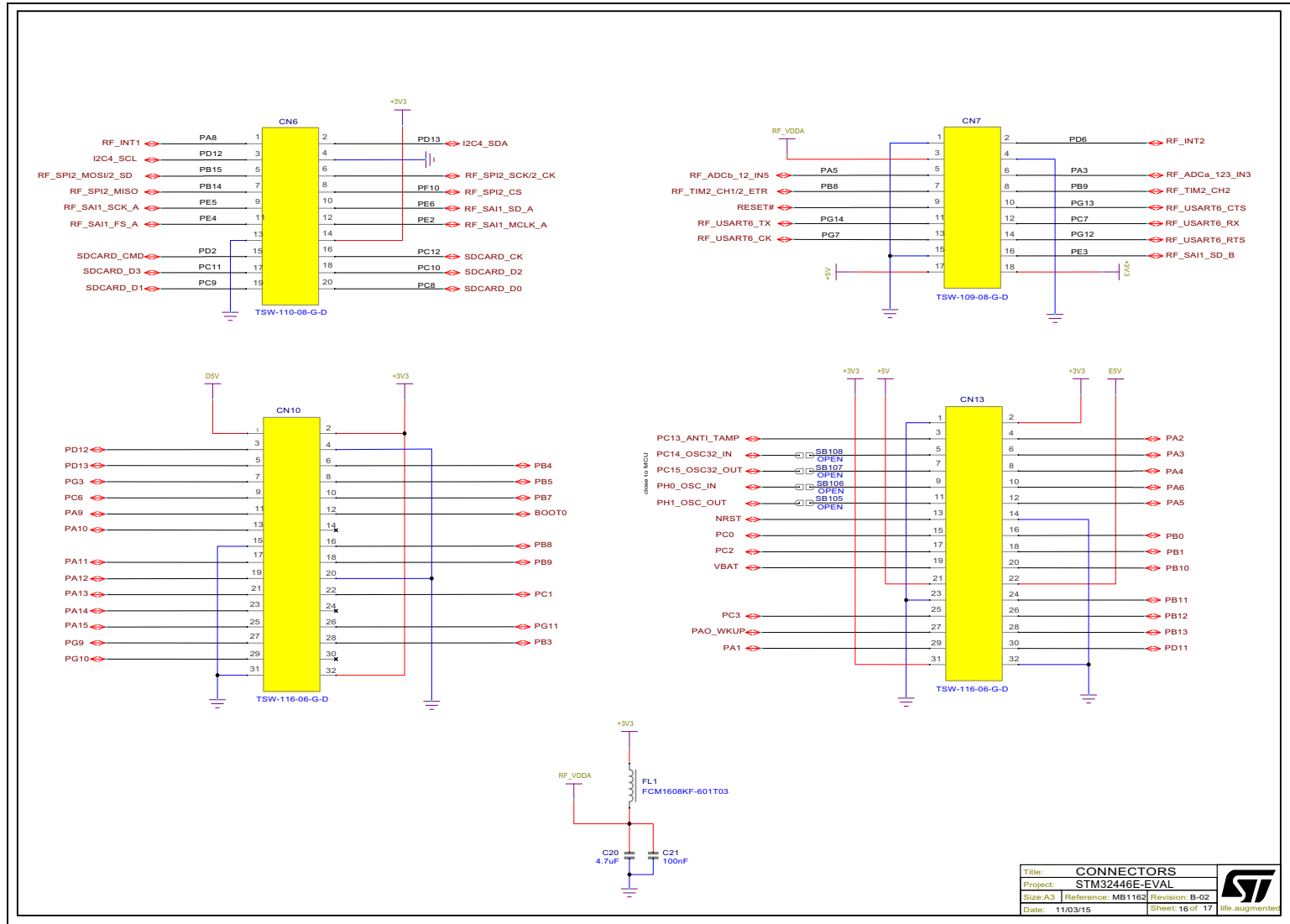


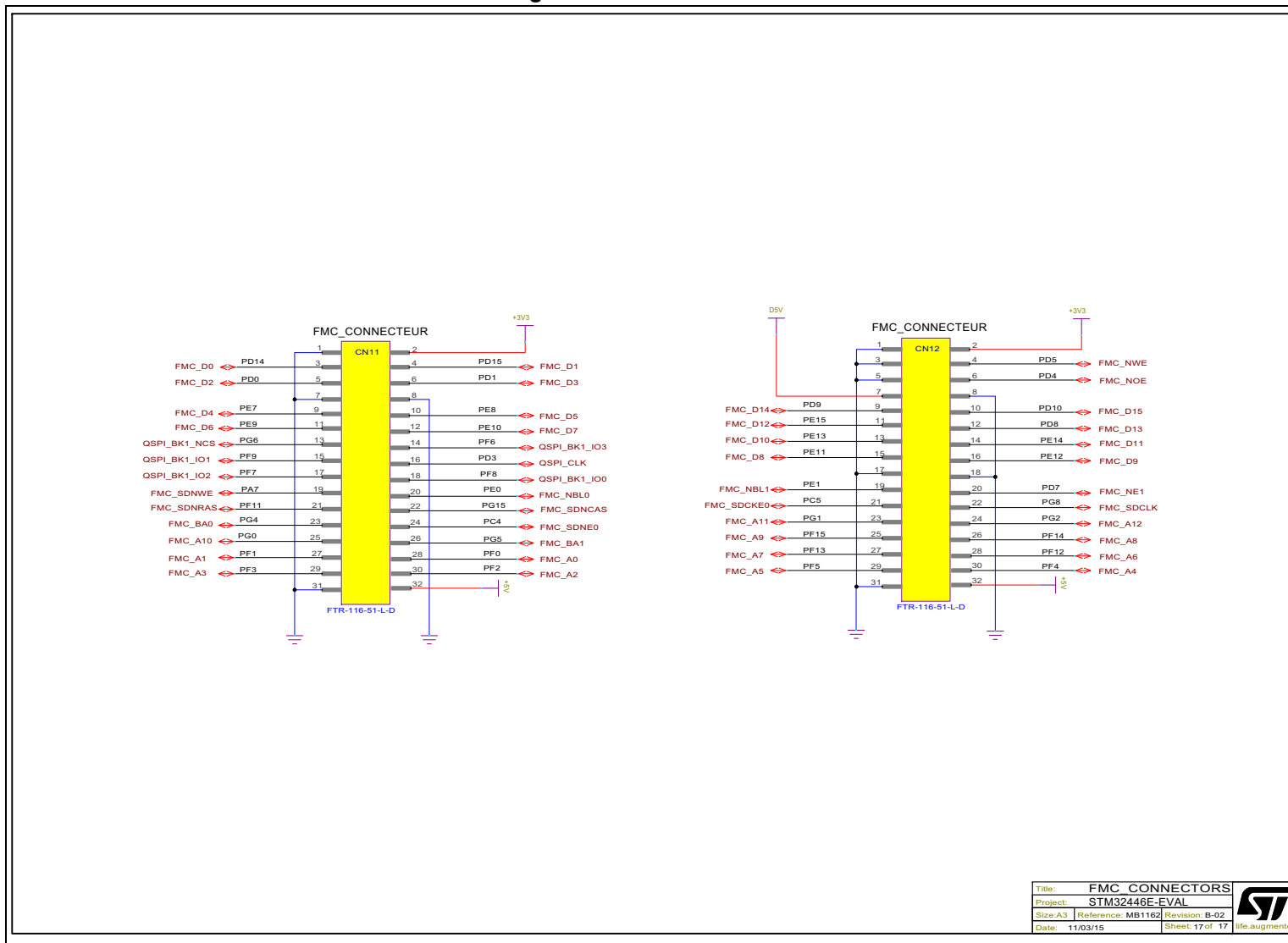
Figure 29. Connectors



Title:	CONNECTORS				
Project:	STM32446E-EVAL				
Size:	A3	Reference:	MB1162	Revision:	B-02
Date:	11/03/15	Sheet:	16 of 17	life.augmented	



Figure 30. FMC connectors



Title:	FMC CONNECTORS		
Project:	STM32446E-EVAL		
Size-A3	Reference: MB1162	Revision: B-02	
Date:	11/03/15	Sheet: 17 of 17	life augmented





Figure 31. 3.2"LCD module with both SPI and 16bit interface

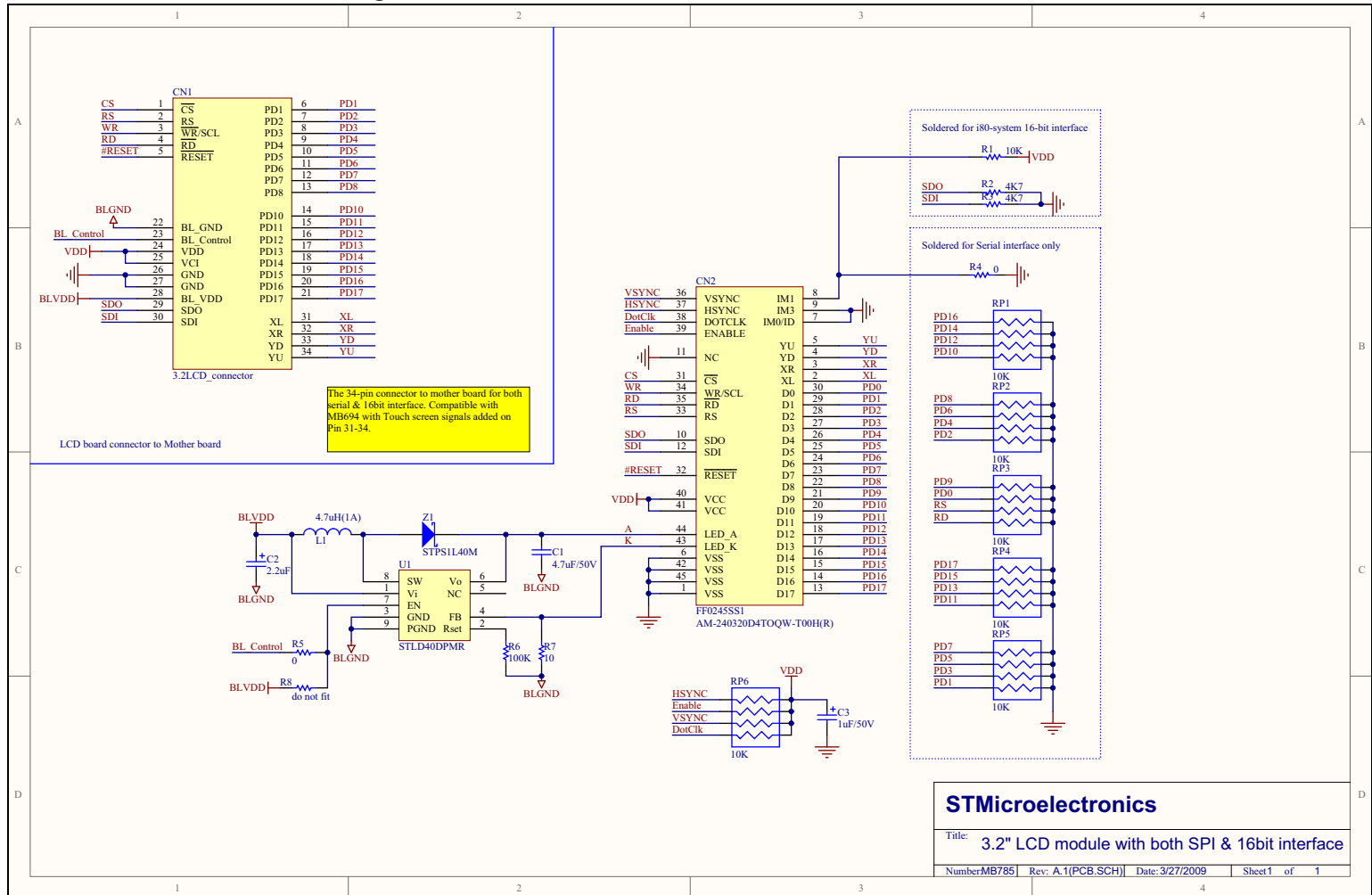
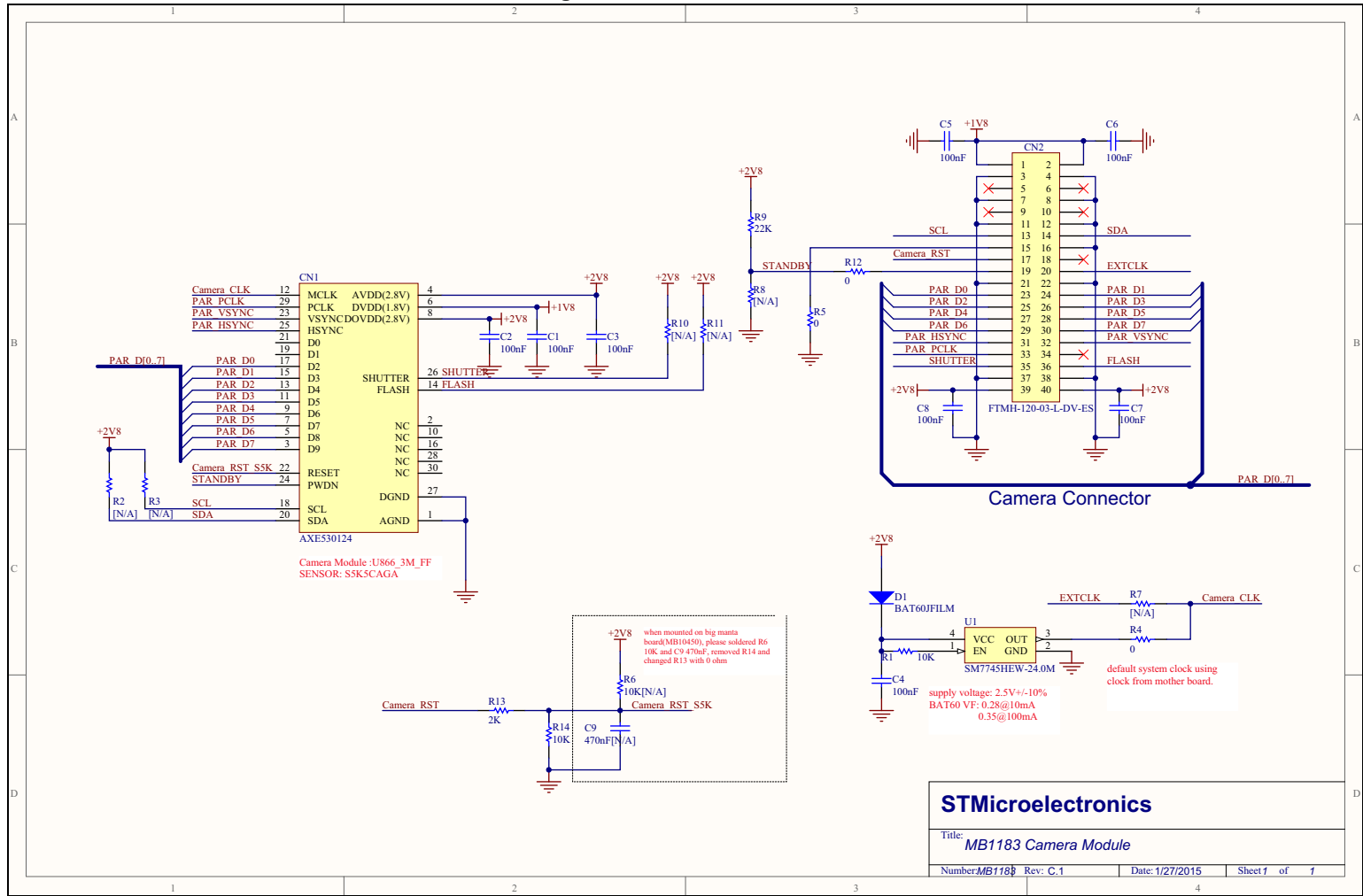


Figure 32. Camera module



Appendix C Mechanical dimensions

Figure 33. Mechanical dimensions

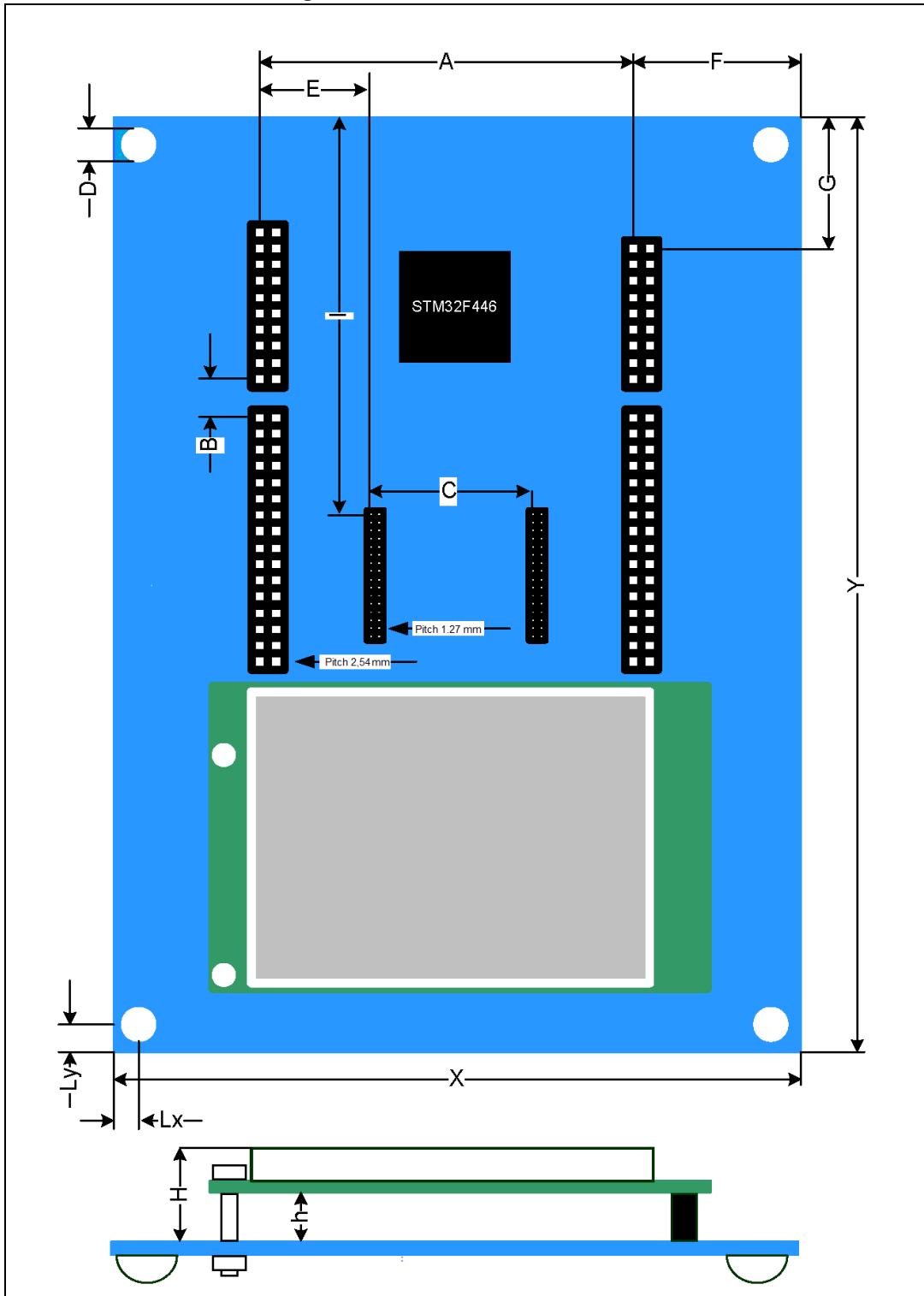


Table 24. Mechanical dimension

Symbol	Size (mm)	Symbol	Size (mm)	Symbol	Size (mm)
X	124.33	A	55.88	E	11.88
Y	172.59	B	5.08	F	35.56
Lx	3.97	C	30.54	G	32.64
Ly	4.16	D	3.5	H	17
-	-	I	772.33	h	10

Appendix D Appendix D: Overview of FCC and IC regulations

D.1 Part 15.19

This device complies with Part 15 of the FCC Rules. Operation is subject to the following two conditions: (1) this device may not cause harmful interference, and (2) this device must accept any interference received, including interference that may cause undesired operation.

D.2 Part 15.105

This equipment has been tested and found to comply with the limits for a Class B digital device, pursuant to part 15 of the FCC Rules. These limits are designed to provide reasonable protection against harmful interference in a residential installation. This equipment generates uses and can radiate radio frequency energy and, if not installed and used in accordance with the instructions, may cause harmful interference to radio communications. However, there is no guarantee that interference will not occur in a particular installation. If this equipment does cause harmful interference to radio or television reception, which can be determined by turning the equipment off and on, the user is encouraged to try to correct the interference's by one or more of the following measures:

- Reorient or relocate the receiving antenna.
- Increase the separation between the equipment and the receiver.
- Connect the equipment into an outlet on a circuit different from that to which the receiver is connected.
- Consult the dealer or an experienced radio/TV technician for help.

D.3 Part 15.21

Any changes or modifications to this equipment not expressly approved by STMicroelectronics may cause, harmful interference and void the FCC authorization to operate this equipment.

D.4 Industry Canada

This device complies with Industry Canada licence-exempt RSS standard(s). Operation is subject to the following two conditions : (1) this device may not cause interference, and (2) this device must accept any interference, including interference that may cause undesired operation.

Le présent appareil est conforme aux CNR d'Industrie Canada applicables aux appareils radio exempts de licence. L'exploitation est autorisée aux deux conditions suivantes : (1) l'appareil ne doit pas produire de brouillage, et (2) l'utilisateur de l'appareil doit accepter tout brouillage radioélectrique subi, même si le brouillage est susceptible d'en compromettre le fonctionnement.

4 Revision History

Table 25. Document Revision History

Date	Version	Revision Details
23-Mar-2015	1	Initial Version

IMPORTANT NOTICE – PLEASE READ CAREFULLY

STMicroelectronics NV and its subsidiaries ("ST") reserve the right to make changes, corrections, enhancements, modifications, and improvements to ST products and/or to this document at any time without notice. Purchasers should obtain the latest relevant information on ST products before placing orders. ST products are sold pursuant to ST's terms and conditions of sale in place at the time of order acknowledgement.

Purchasers are solely responsible for the choice, selection, and use of ST products and ST assumes no liability for application assistance or the design of Purchasers' products.

No license, express or implied, to any intellectual property right is granted by ST herein.

Resale of ST products with provisions different from the information set forth herein shall void any warranty granted by ST for such product.

ST and the ST logo are trademarks of ST. All other product or service names are the property of their respective owners.

Information in this document supersedes and replaces information previously supplied in any prior versions of this document.

© 2015 STMicroelectronics – All rights reserved