

VANGUARD®

DIRECT-VENT GAS FIREPLACE HEATER OWNER'S OPERATION AND INSTALLATION MANUAL

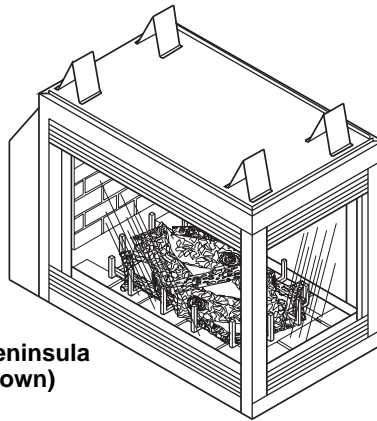

(Peninsula
Shown)



VDVF36PN/PP (PENINSULA) AND VDVF36STN/STP (SEE THRU)

WARNING: If the information in these instructions is not followed exactly, a fire or explosion may result causing property damage, personal injury, or loss of life.

- Do not store or use gasoline or other flammable vapors and liquids in the vicinity of this or any other appliance.
- WHAT TO DO IF YOU SMELL GAS :
 - Do not try to light any appliance.
 - Do not touch any electrical switch;
 - Do not use any phone in your building.
 - Immediately call your gas supplier from a neighbor's phone. Follow the gas supplier's instructions.
 - If you cannot reach your gas supplier, call the fire department.
- Installation and service must be performed by a qualified installer, service agency, or the gas supplier.

SAVE THIS BOOK

This book is valuable. In addition to instructing you on how to install and maintain your appliance, it also contains information that will enable you to obtain replacement parts or optional accessory items when needed. Keep it with your other important papers.

WARNING: Improper installation, adjustment, alteration, service, or maintenance to this appliance can cause injury or property damage. Refer to this manual. For assistance or additional information consult a qualified installer, service agency, or the gas supplier.

WARNING: This Direct-Vent Gas Fireplace Heater series is intended for use with Natural or Propane/LP gas only. Do not attempt to burn any solid fuels in these appliances.

CHECK LOCAL CODES PRIOR TO INSTALLATION

This appliance may be installed in an aftermarket* permanently located, manufactured (mobile) home, where not prohibited by state or local codes.

This appliance is only for use with the type of gas indicated on the rating plate.

This appliance is not convertible for use with other gases, unless a certified kit is used.

*Aftermarket: Completion of sale, not for purpose of resale, from the manufacturer.

Save this manual for future reference.

VANGUARD® VDV36P and VDV36ST Series DIRECT-VENT GAS FIREPLACE HEATER

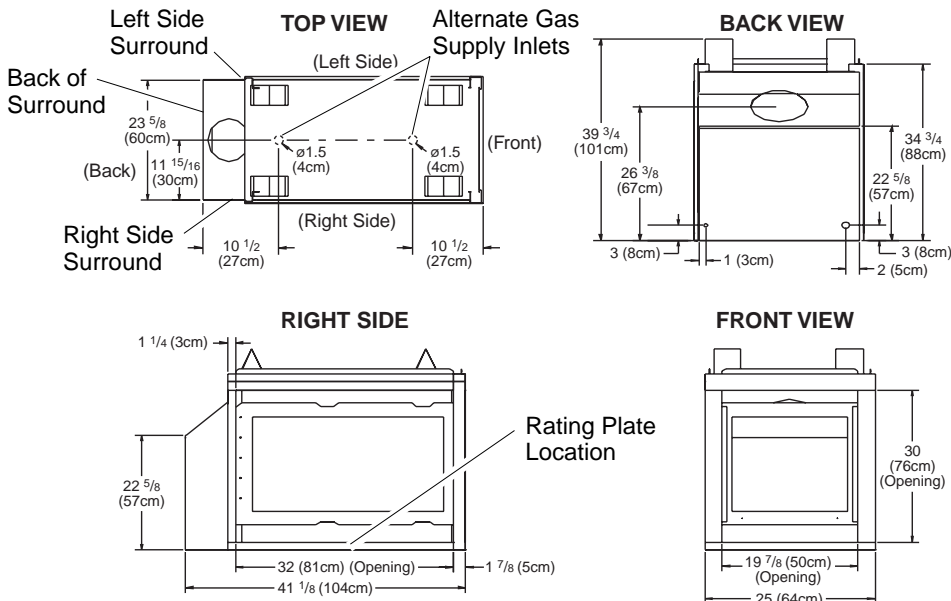

Figure 1 - VDV36PN/PP (Peninsula) Dimensions

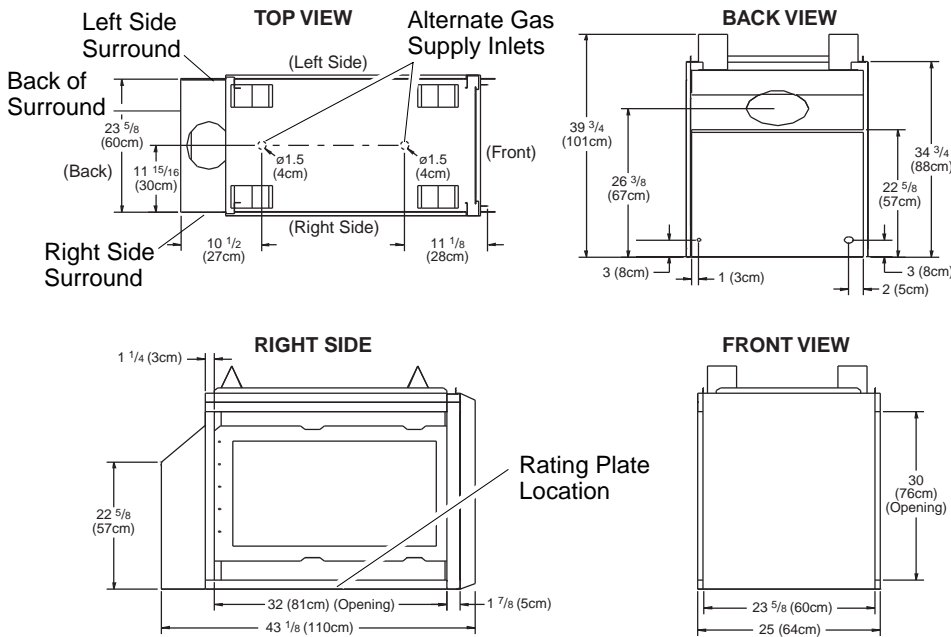

Figure 2 - VDV36STN/STP (See Thru) Dimensions

Note: All dimensions in this manual are in inches unless otherwise specified.

GLOSSARY OF TERMS

Chase - A box-like enclosure to protect venting from the elements when the venting run is on the outside of a structure.

Mastic - A pliable sealant for use around the vent terminal.

Snorkel Termination - A box that raises the horizontal termination above ground level clearances.

Vent Terminal - Mounted on an outside wall or roof to separate the inlet and outlet of the vent system and protect it from weather.

Vinyl Siding Standoff - A metal box that separates the vent cap from vinyl siding.

Wall Thimble/Firestop - A metal plate used to secure the vent pipe when it passes through a wall or ceiling.

OWNER'S MANUAL

INTRODUCTION

Models VDVF36PN/PP series are three-sided direct-vent gas fireplace heaters with a sealed combustion chamber. Models VDVF36STN/STP series are two-sided direct-vent gas fireplace heaters with a sealed combustion chamber. All models use a millivolt gas control and a millivolt ignition system. All models have a manual HI/LO valve to control the flame height. A fan kit is available for these models as an option.

NOTICE: Check local building codes for area requirements before installing this appliance.

- Models VDVF36PN and VDVF36STN use NATURAL GAS ONLY.
- Models VDVF36PP and VDVF36STP use PROPANE/LP GAS ONLY.

If you have any doubts as to which gas your particular appliance is approved and tested for, please check the AGA/CGA rating plate located at the interior of the appliance opening or consult your local distributor (see Figures 1 and 2, page 2).

BEFORE YOU BEGIN

Before beginning the installation of your appliance, read these instructions through completely.

This DESA appliance and its approved components are safe when installed according to this installation manual and operated as recommended by DESA. Unless you use DESA approved components tested for this appliance, **YOU MAY CAUSE A SAFETY HAZARD!**

The DESA warranty will be voided by, and DESA disclaims any responsibility for the following actions:

- A) Modification of the appliance or any of the components manufactured by DESA unless otherwise permitted in writing by DESA.
- B) The use of any components part not approved by DESA in combination with this DESA appliance.
- C) Installation and/or operation in a manner other than instructed in this manual.
- D) The burning of anything other than the type of gas approved for use in this gas appliance.

This appliance, when installed, must be electrically grounded in accordance with local codes, or in the absence of local codes, with the *National Electrical Code, ANS/NFPA 70* or the *Canadian Electrical Code, CSA C22.1*.

The installation must conform with local codes or, in the absence of local codes, with the *National Fuel Gas Code, ANS Z223.1* or the *Canadian Installation Code, CAN/CGA B149*.

This appliance complies with ANS Z21.88-1998 and CSA 2.33-M98 as a VENTED GAS FIREPLACE HEATER. It is listed and tested by International Approval Services.

NOTICE: This appliance is intended to be used only for supplemental heat.

⚠ WARNING: Installation and repair should be done by a qualified service person. The appliance should be inspected before use, and at least annually thereafter by a qualified service person. More frequent cleaning may be required due to excessive lint from carpeting, bedding, pet hair, etc. It is imperative that the control compartments, burners, and circulating air systems be kept clean.

SELECTING LOCATION

To determine the safest and most efficient location for your appliance, consider the following guidelines:

1. The location must allow for proper clearances (see *Clearances*, page 4).
2. Consider a location where heat output would not be affected by drafts, air conditioning ducts, windows, or doors.
3. A location that avoids the cutting of joists or roof rafters makes installation easier.

In selecting a location, the following precautions must be observed:

1. A projection may be ideal for a new addition on an existing finished wall. See *Horizontal Termination Configuration*, pages 10 and 11, or *Vertical Termination Configuration*, pages 13 and 14.
2. Do not locate appliance close to where gasoline or other flammable liquids may be stored. The appliance must be kept clear and free from combustible materials.
3. Do not connect this appliance to a chimney system used for solid fuel burning fireplace.
4. Due to high temperatures, do not locate this appliance in high traffic areas or near furniture and draperies.
5. This fireplace may be installed in bedrooms or bathrooms in accordance with local codes.
6. Never obstruct the openings of the appliance or flow of ventilation air. Keep the control compartments accessible.
7. Do not use this appliance if any part has been under water. Immediately contact a local service technician to examine the appliance and to replace any part(s) of the control ignition system and other related components that have submerged under water.

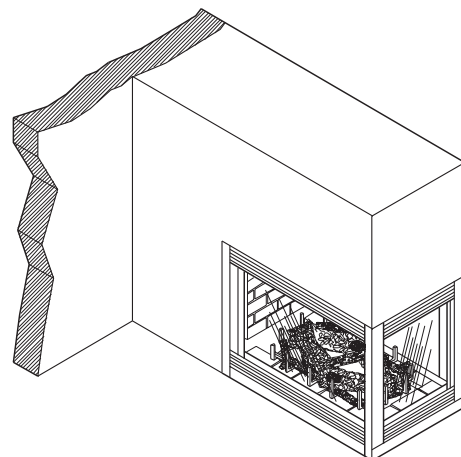

Figure 3 - Possible Installation of Peninsula Fireplace

VANGUARD® VDVVF36P and VDVVF36ST Series DIRECT-VENT GAS FIREPLACE HEATER

PRE-INSTALLATION PREPARATION

CLEARANCES

Minimum clearances to combustibles are:

- Back and Sides of Surround: 0" min.
- Vent Surfaces: 1" (2.5cm) min.
- Ceiling to Opening: ... 36" (91cm) min.
- Floor: 0" min.
- Wall to Front of Glass: 36" (91cm) min.
- Perpendicular Wall to Opening of Unit: 2" (5cm) min.
- Top Spacer: 0" min.

⚠ CAUTION: Do not block required air spaces with insulation or any other material. Do not obstruct the effective opening of the appliance with any type of facing material.

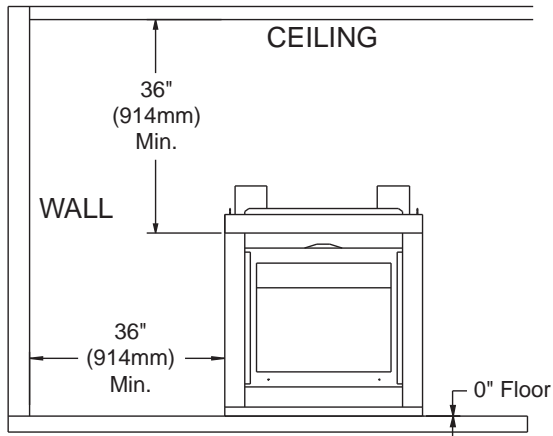

Figure 4 - Minimum Clearances (Peninsula Shown)

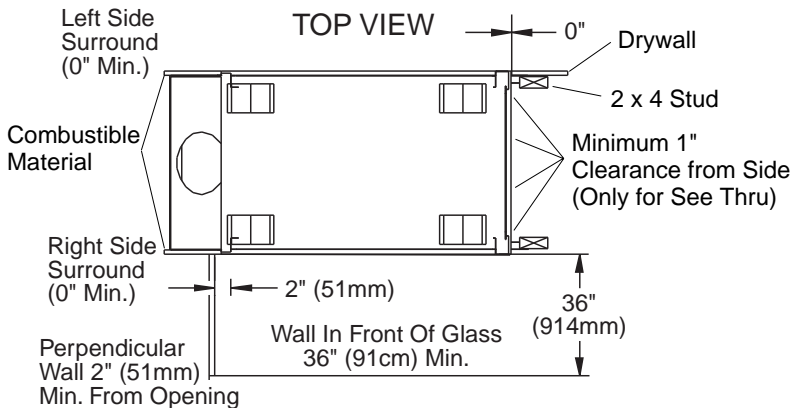

Figure 5 - Minimum Clearances (See Thru Shown)

MANTEL CLEARANCES

Woodwork, such as wood trims, mantles, and other combustible materials projecting no more than 1 1/2 inches (3.8cm) shall not be placed within 7 inches (17.8cm) from the opening of the unit. Combustible material above and projecting more than 1 1/2 inches (3.8cm) from the appliance's face must not be placed less than 15 inches (38.1cm) from the opening of the appliance (see Figure 6).

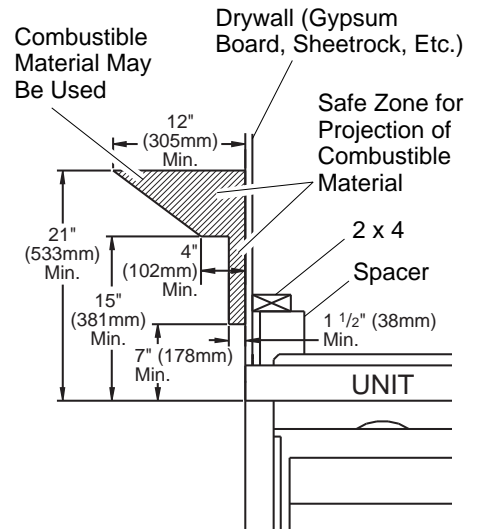

Figure 6 - Mantel Clearances for Peninsula and See Thru Fireplaces (Peninsula Shown)

FRAMING

Once the final location has been determined, observing height clearances for vent termination, you may construct framing using dimensions shown in Figures 7 through 9, page 5, depending on your installation.

If the appliance is to be installed directly on carpeting, tile (other than ceramic), or any combustible material other than wood flooring, the appliance must be installed on a metal or wood panel extending the full width and depth of the appliance. There are three holes on each side of the bottom of the unit where screws can be used to secure the unit to the floor.

PRE-INSTALLATION PREPARATION

Continued

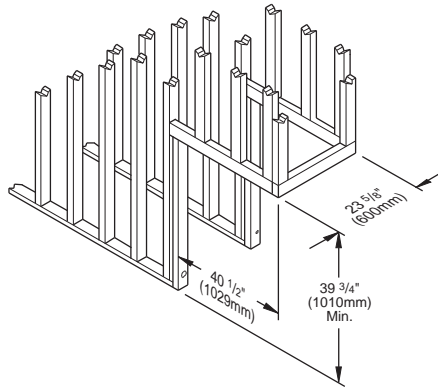

Figure 7 - Rough Opening for Installing Peninsula Fireplace

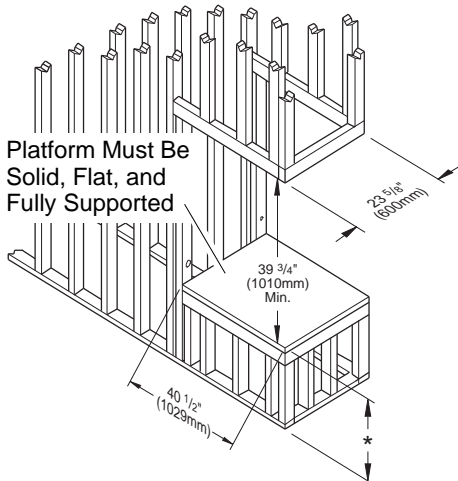

Figure 8 - Rough Opening for Installing Peninsula Fireplace on Platform

* As required by design as long as ceiling clearance is maintained.

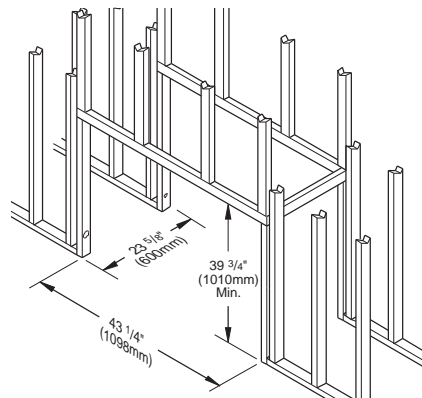

Figure 9 - Rough Opening for Installing See Thru Fireplace

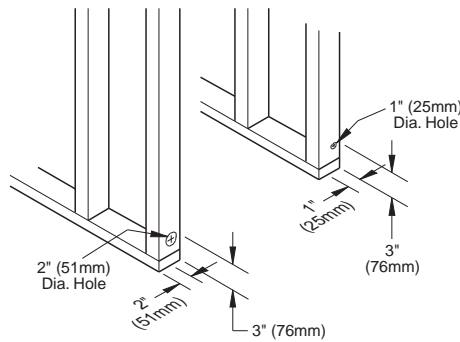

Figure 10 - Hole Locations For Gas Line and Electric Wires for Peninsula and See Thru Fireplaces

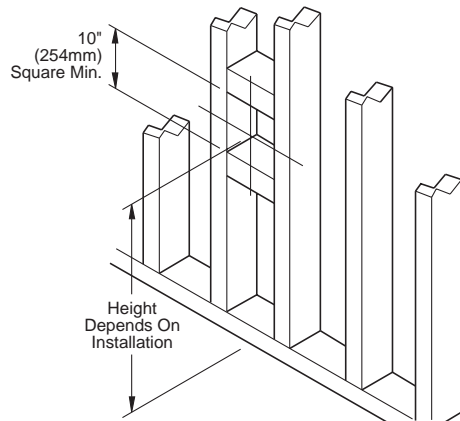

Figure 11 - Rough Opening for Installing Exterior Vent Terminal

Refer to Pages 8 through 14 for Horizontal and Vertical Installation Details

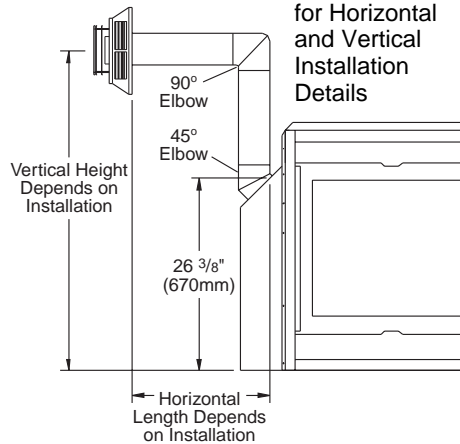

Figure 12 - Vent Opening Height

GENERAL VENTING

These models are approved for use with Simpson Dura-Vent 6 5/8" direct-vent pipe components and terminations as well as both flex and rigid Vanguard vent components.

Your fireplace is approved to be vented either through the side wall, or vertically using the following guidelines:

- Only use Vanguard or Simpson Dura-Vent GS venting components or kits specifically approved for this fireplace.
- Minimum clearance between vent pipes and combustible materials is 1" (25 mm), except where stated otherwise.
- Combustible material may be flush with the top front of fireplace with a maximum thickness of 3/4".
- Do not recess venting terminals into a wall or siding.
- Install horizontal venting with a 1/4" rise for every 12" of run toward the termination.
- You may paint the vent terminal with 450°F (232°C) heat-resistant paint to coordinate with the exterior finish.
- There must not be any obstruction such as bushes, garden sheds, fences, decks, or utility buildings within 24" from the front of the termination cap.
- Do not locate termination cap where excessive snow or ice build up may occur. Be sure to clear vent termination area after snow falls to prevent accidental blockage of venting system. When using snow blowers, do not direct snow towards vent termination area.

LOCATION OF VENT TERMINATION

When locating vent termination, it is important to observe the minimum clearances shown in Figure 13, page 6. You will avoid extra framing by positioning your fireplace against an already existing framing member. The sides of the fireplace may be positioned directly against combustible walls.

*Check with local codes or with the current *CAN/CGA B149[.1 or .2] Installation Codes* for Canada or the USA Installations follow the current *National Fuel Gas Code, ANS Z223.1*, also known as NFPA 54.

Continued

VANGUARD® VDV36P and VDV36ST Series DIRECT-VENT GAS FIREPLACE HEATER

GENERAL VENTING *Continued*

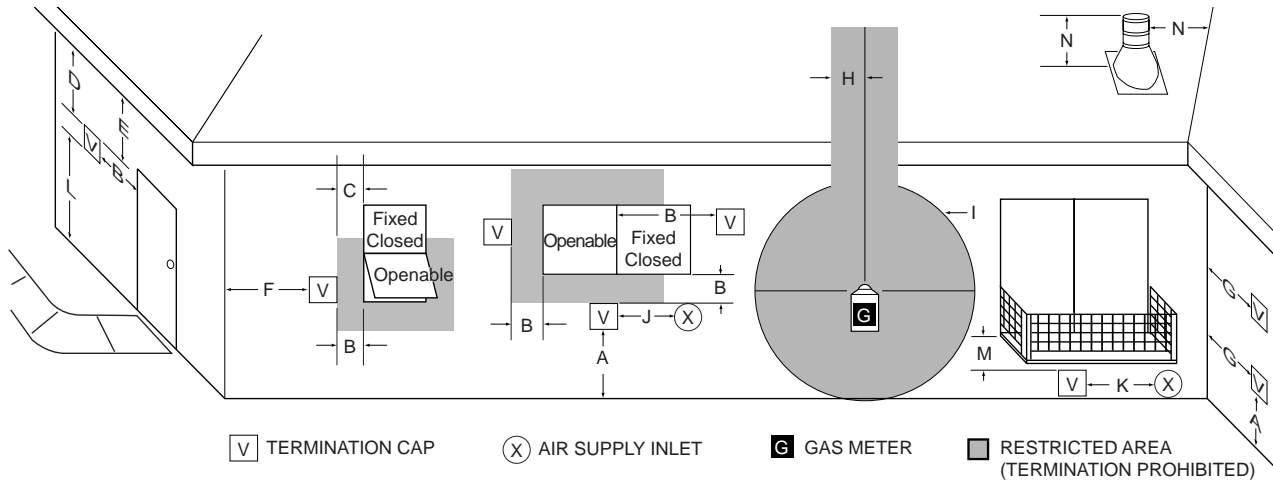

- A = clearance above grade, veranda, porch, deck, or balcony [*12 inches (305mm) minimum]
- B = clearance to window or door that may be opened [12 inches (305mm) minimum]
- C = clearance to permanently closed window [minimum 12 inches (305mm) recommended to prevent condensation on window]
- D = vertical clearance to ventilated soffit located above the terminal within a horizontal distance of 24 inches (610mm) from the center-line of the terminal [18 inches (457mm) minimum]
- E = clearance to unventilated soffit [12 inches (305mm) minimum]
- F = clearance to outside corner (see below)
- G = clearance to inside corner (see below)
- H = *not to be installed above a meter/regulator assembly within 36 inches (914mm) horizontally from the center-line of the regulator
- I = clearance to service regulator vent outlet [*72 inches (1829mm) minimum]
- J = clearance to non-mechanical air supply inlet to building or the combustion air inlet to any other fireplace [*12 inches (305mm) minimum]
- K = clearance to a mechanical air supply inlet [*72 inches (1829mm) minimum]
- L = † clearance above paved side-walk or a paved driveway located on public property [*84 inches (2133mm) minimum]
- M = clearance under veranda, porch, deck [*12 inches (305mm) minimum ‡]
- N = clearance above a roof shall extend a minimum of 24 inches (610mm) above the highest point when it passes through the roof surface and any other obstruction within a horizontal distance of 18 inches (457mm)

† vent shall not terminate directly above a side-walk or paved driveway which is located between two single family dwellings and serves both dwellings*
 ‡ only permitted if veranda, porch, deck or balcony is fully open on a minimum of 2 sides beneath the floor*
 * as specified in CAN/SGA B149 (.1 or .2) Installation Codes (1991) for Canada or for U.S.A. installation follow the current *National Fuel Gas Code, ANS Z223.1*
 Note: Local codes or regulations may require different clearances

Termination Clearances for Buildings with Combustible and Noncombustible Exteriors

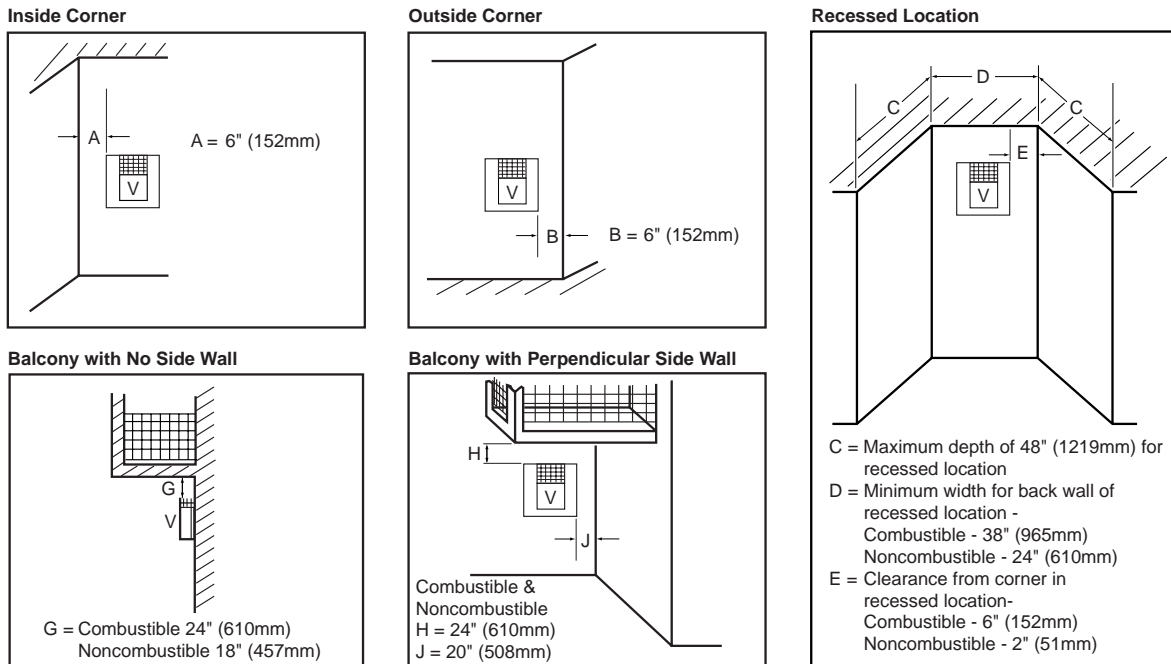

Figure 13 - Minimum Clearances for Vent Terminations

VENTING INSTALLATION

⚠ WARNING: Read all instructions completely and thoroughly before attempting installation. Failure to do so could result in serious injury, property damage or loss of life. Operation of improperly installed and maintained venting system could result in serious injury, property damage or loss of life.

⚠ WARNING: Seal all of the connections with high temperature silicone (600°F/316°C) every time a vent connection is made. Before joining elbows and pipes, apply a bead of high temperature silicone sealant (GE RTV 106/Loctite RTV 81585) to the end of the elbow or pipe. High temperature silicone must also be used to re-seal any connections after maintenance to venting system.

NOTICE: Failure to follow these instructions will void the warranty.

INSTALLATION PRECAUTIONS

Consult local building codes before beginning the installation. The installer must make sure to select the proper vent system for installation. Before installing vent kit, the installer must read this fireplace manual and vent kit instructions.

Only a qualified service person should install venting system. The installer must follow these safety rules:

- Wear gloves and safety glasses for protection
- Use extreme caution when using ladders or when on roof tops
- Be aware of electrical wiring locations in walls and ceilings

The following actions will void the warranty on your venting system:

- Installation of any damaged venting component
- Unauthorized modification of the venting system

- Installation of any component part not manufactured or approved by DESA International
- Installation other than as instructed by these instructions

⚠ WARNING: This gas fireplace and vent assembly must be vented directly to the outside. The venting system must NEVER be attached to a chimney serving a separate solid fuel burning appliance. Each gas appliance must use a separate vent system. Do not use common vent systems.

⚠ WARNING: Horizontal sections of this vent system require a minimum clearance of 2" from the top of the pipe and 1" minimum to the sides and bottom. Vertical sections of this system require a minimum of 1" clearance to combustible materials on all sides of the pipe.

INSTALLATION PLANNING

There are two basic types of direct-vent installation:

- Horizontal Termination
- Vertical Termination

It is important to select the proper length of vent pipe for the type of termination you choose. It is also important to note the wall thickness.

For Horizontal Termination: Select the amount of vertical rise desired. The horizontal run of venting must have 1/4" rise for every 12" of run towards the termination.

⚠ WARNING: Never run the vent downward as this may cause excessive temperatures which could cause a fire.

You may use one or two 90° elbows in this vent configuration. See *Horizontal Termination Configurations* on pages 10 and 11.

For Vertical Termination: Measure the distance from the fireplace flue outlet to the ceiling. Add the ceiling thickness, the vertical rise in an attic or second story, and allow for sufficient vent height above the roofline.

You may use one or two 90° elbows in this vent configuration. See *Vertical Termination Configurations* on pages 13 and 14.

Note: You may use two 45° elbows in place of a 90° elbow. You must follow rise to run ratios when using 45° elbows.

For two-story applications, firestops are required at each floor level. If an offset is needed in the attic, additional pipe and elbows will be required.

You may use a chase with a vent termination with exposed pipe on the exterior of the house. See *Installing Vent System in a Chase*, below.

Your Vanguard direct-vent fireplace has been tested for a minimum 3' rise with a maximum 10" wall thickness. The maximum horizontal run is 20' with 8' vertical rise (see *Installation for Horizontal Termination*, page 8). The maximum vertical run is 30' (see *Installation for Vertical Termination*, page 12).

It is very important that the venting system maintain its balance between the combustion air intake and the flue gas exhaust. Certain limitations apply to vent configurations and must be strictly followed.

Installing Vent System in a Chase

A chase is a vertical box-like structure built to enclose venting that runs along the outside of a building. A chase is not required for such venting.

NOTICE: Treatment of firestops and construction of the chase may vary from building type to building type. These instructions are not substitutes for the requirements of local building codes. You must follow all local building codes.

Note: When installing in a chase, you should insulate the chase as you would the outside walls of your home. This is especially important in cold climates. Minimum clearance between vent pipes and combustible materials such as insulation is 1".

After framing the chase (see *Framing* on pages 4 and 5) install the vent system by following the installation instructions.

Continued

VANGUARD® VDV36P and VDV36ST Series DIRECT-VENT GAS FIREPLACE HEATER

VENTING INSTALLATION

Continued

INSTALLATION FOR HORIZONTAL TERMINATION

1. Determine the route your horizontal venting will take. *Note:* The location of the horizontal vent termination on the exterior wall must meet all local and national building codes and must not be easily blocked or obstructed.

⚠ WARNING: Do not recess vent terminal into a wall or siding.

Snorkel terminations are available for terminations requiring a vertical rise on the exterior of the building (see Figures 14 and 15). Snorkel kit SVK is also available (see page 15). Follow the same installation procedures used for standard horizontal terminations. If installing the snorkel termination below grade (basement applications), you must provide proper drainage to prevent water from entering the snorkel termination (see Figure 15). Do not back fill around the snorkel termination.

2. Rigid vent pipes and fittings have special twist-lock connections. Assemble the desired combination of pipe and elbows to the appliance adaptor with pipe seams oriented towards the wall or floor.

Twist-lock Procedure: The female ends of the pipes and fittings have four locking lugs (indentations). These lugs will slide straight into matching slots on the male ends of adjacent pipes and fittings. (All connections must be sealed with high temperature silicone sealant as specified in the second warning statement on page 7.) Push the pipe sections together and twist one section clockwise approximately one-quarter turn until the sections are fully locked. See Figure 16, page 9. *Note:* Horizontal runs of vent must be supported every three feet. Use wall straps for this purpose.

Flexible vent pipe must be installed with spacer springs every 12". See Figure 16, page 9. All connections must be clamped tightly and sealed with high temperature silicone sealant as specified in the second warning statement on page 7.

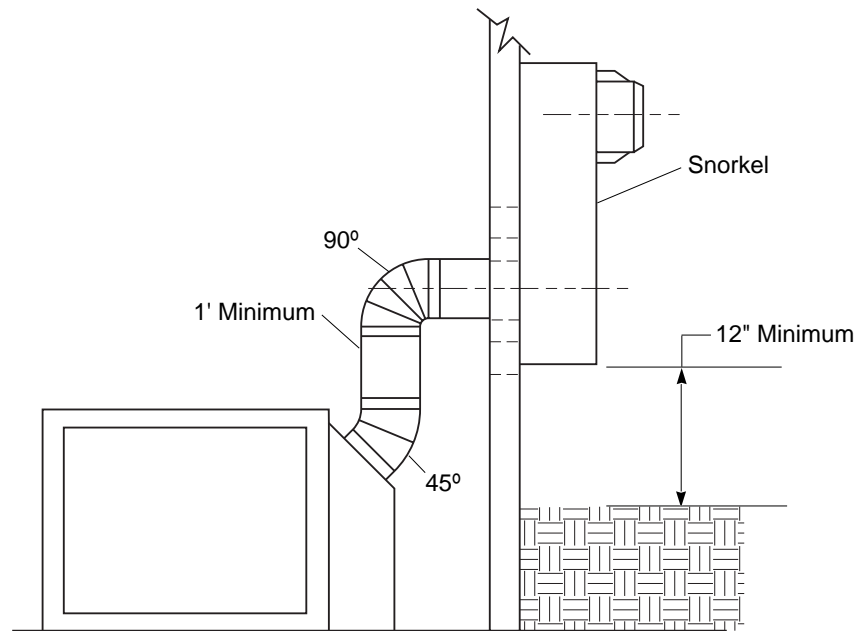

Figure 14 - Snorkel Termination

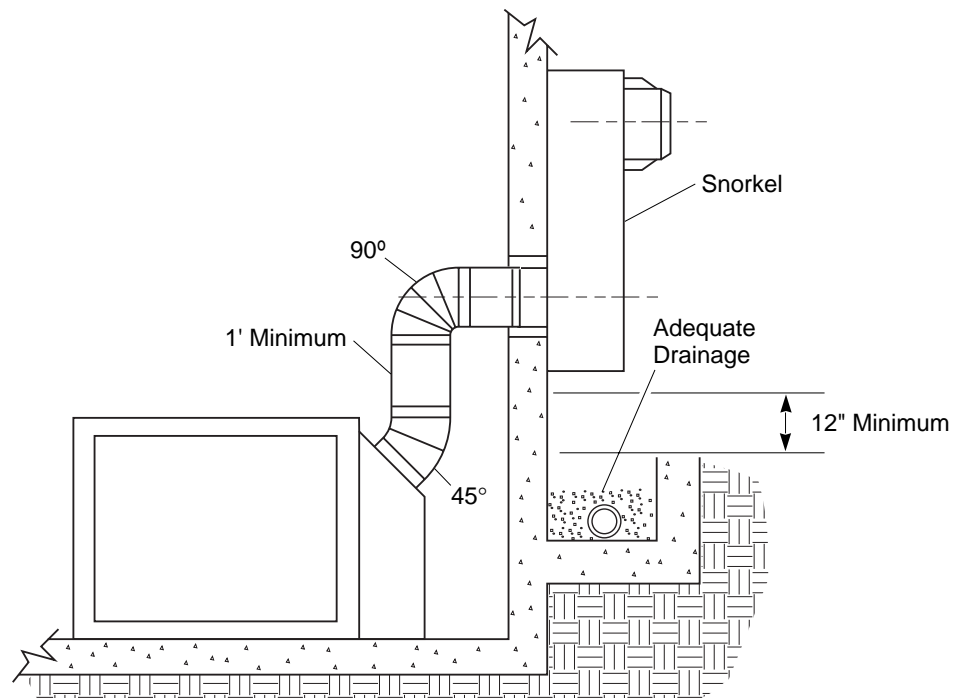

Figure 15 - Snorkel Termination with Drainage Pipe

VENTING INSTALLATION

Continued

- Attach vent pipe assembly to the fireplace. Set fireplace in front of its permanent location to insure minimum clearances. Mark the wall for a 10" square hole (for noncombustible material such as masonry block or concrete, a 7 1/2" diameter hole is acceptable). See Figure 17. The center of the hole should line up with the centerline of the horizontal rigid vent pipe. Cut a 10"x10" (254mm x 254mm) square hole through combustible exterior wall (7 1/2" [190mm] diameter hole if noncombustible). Frame as necessary (see Figure 17).

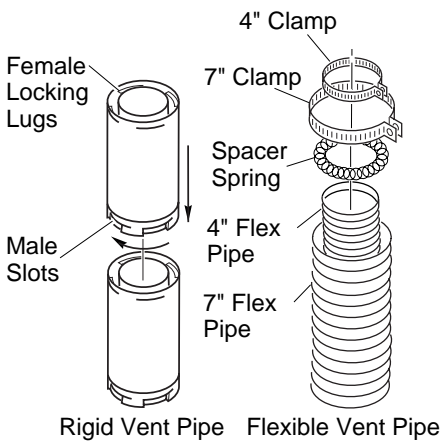

Figure 16 - Vent Pipe Connections

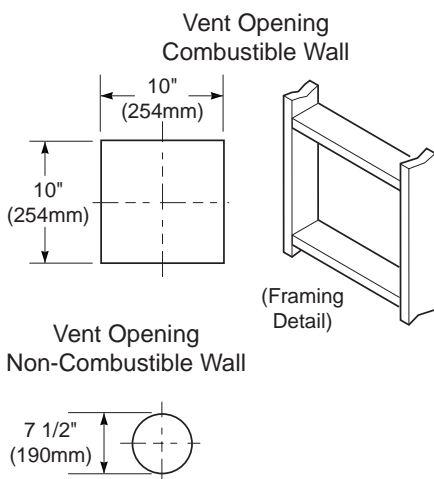

Figure 17 - Vent Opening Requirements

- Apply a bead of non-hardening mastic around the outside edge of the vent cap. Position the vent cap in the center of the 7 1/2" or 10" hole on the exterior wall with the arrow on the vent cap pointing up. Insure proper clearance of 1" to combustibles is maintained. Attach the vent cap with four wood screws supplied (see Figure 18). **Note:** Replace the wood screws with appropriate fasteners for stucco, brick, concrete, or other types of siding.

WARNING: Do not recess vent termination in to any wall. This will cause a fire hazard.

For vinyl siding use vinyl siding stand-offs between vent cap and exterior wall. The vinyl siding standoff prevents excessive heat from melting the vinyl siding material. Bolt the vent cap to the standoff. Apply non-hardening mastic around outside edge of the standoff instead of the vent cap assembly. Use wood screws provided to attach the standoff. See Figure 19.

- Slide the wall thimble over the vent pipe before connecting the horizontal run to the vent cap (see Figure 20).

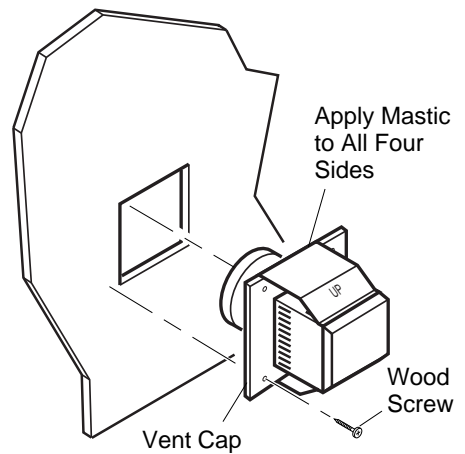

Figure 18 - Installing Horizontal Vent Cap

- Carefully move the fireplace with vent assembly attached toward the wall and insert the vent pipe into the horizontal termination. The pipe overlap should be a minimum of 1 1/4". Apply silicone to the connection. Fasten all vent connections with screws provided. Refer to *Framing* on pages 4 and 5 for instructions on securing unit to framing or floor.
- Slide the wall thimble against the interior wall surface and attach with screws provided (see Figure 20).

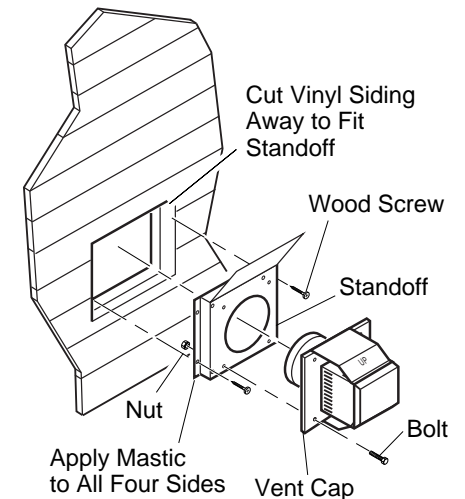

Figure 19 - Installing Vinyl Siding Standoff

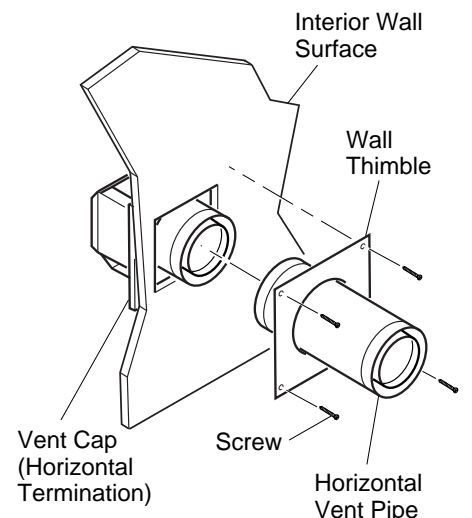

Figure 20 - Connecting Vent Cap with Horizontal Vent Pipe

VANGUARD® VDV36P and VDV36ST Series DIRECT-VENT GAS FIREPLACE HEATER

VENTING INSTALLATION

Continued

Horizontal Termination Configurations

Figures 21 through 23 show different configurations for venting with horizontal termination. Each figure includes a chart with vertical minimum/maximum and horizontal maximum dimensions which must be met. All connections must be sealed with high temperature silicone sealant as specified in the second warning statement on page 7. All horizontal terminations require 1/4" rise per 12" of horizontal run.

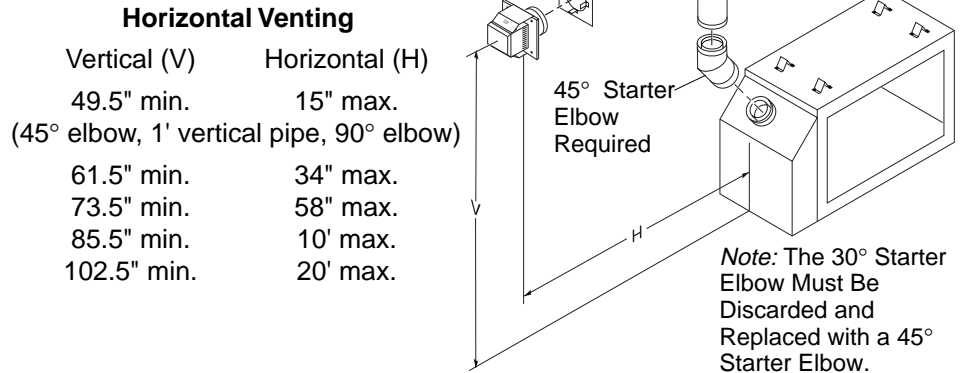

Figure 21 - Horizontal Termination Configuration for Rigid Venting Using One 90° Elbow

Horizontal Venting

See information in Figure 21 for Vertical(V) and Horizontal(H) maximums and minimums. The same amounts apply for flexible venting.

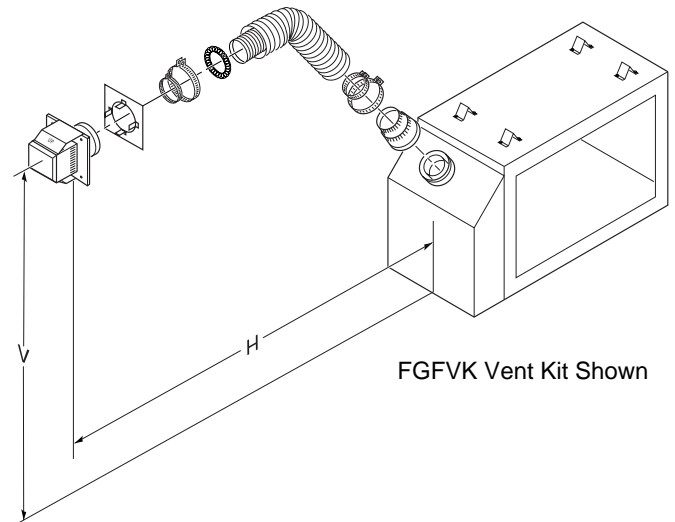

Figure 22 - Horizontal Termination Using Flexible Venting

VENTING INSTALLATION *Continued*

Venting with Two 90° Elbows

Vertical (V)	Horizontal (H ₁) + Horizontal (H ₂)
5' min.	4' max.
6' min.	8' max.
7' min.	10' max.
8' min.	15' max.
20' max.	20' max.

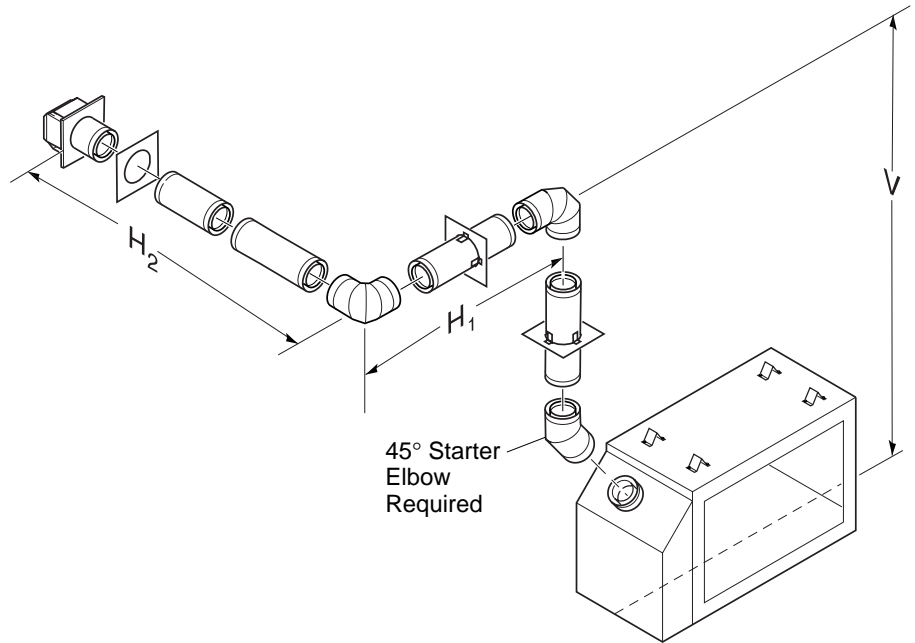

Figure 23 - Horizontal Termination Configuration for Rigid Venting Using Two 90° Elbows with Termination at 90° with Fireplace

Continued

VANGUARD® VDVF36P and VDVF36ST Series DIRECT-VENT GAS FIREPLACE HEATER

VENTING INSTALLATION

Continued

INSTALLATION FOR VERTICAL TERMINATION

NOTICE: Use rigid pipe only. Flex venting is not to be used with a vertical termination.

1. Determine the route your vertical venting will take. If ceiling joists, roof rafters, or other framing will obstruct the venting system, consider an offset (see Figure 24) to avoid cutting loadbearing members. *Note:* Pay special attention to these installation instructions for required clearances (air space) to combustibles when passing through ceilings, walls, roofs, enclosures, attic rafters, etc. Do not pack air spaces with insulation. Also note maximum vertical rise of the venting system and any maximum horizontal offset limitations. Offsets must fall within the parameters shown in Figure 13 on page 6.
2. Set the fireplace in desired location. Drop a plumb line down from the ceiling to the position of the fireplace exit flue. Mark the center point where the vent will penetrate the ceiling. Drill a small locating hole at this point.
Drop a plumb line from the inside of the roof to the locating hole in the ceiling. Mark the center point where the vent will penetrate the roof. Drill a small locating hole at this point.

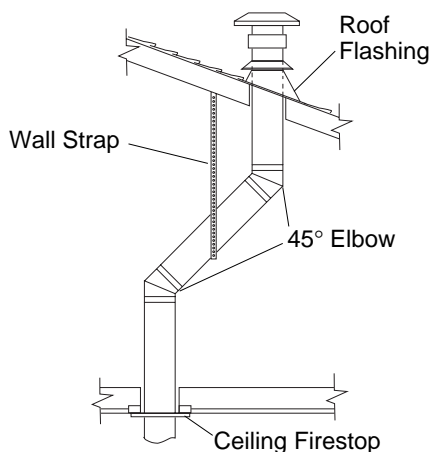
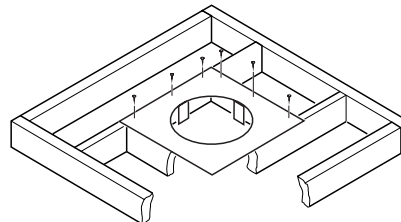

Figure 24 - Offset with Wall Strap and 45°

Flat Ceiling Installation

1. Cut a 10" square hole in the ceiling using the locating hole as a center point. The opening should be framed to 10"x10" (254mm x 254mm) inside dimensions, as shown in Figure 17 on page 9 using framing lumber the same size as the ceiling joists. If the area above the ceiling is an insulated ceiling or a room, nail firestop from the top side. This prevents loose insulation from falling into the required clearance space. Otherwise, install firestop below the framed hole. The firestop should be installed with no less than three nails per side (see Figure 25).
2. Assemble the desired lengths of pipe and elbows necessary to reach from the fireplace flue up through the firestop. All connections must be sealed with high temperature silicone sealant as specified in the second warning statement on page 7. Be sure all pipe and elbow connections are fully twist-locked (see Figure 16, page 9).
3. Cut a hole in the roof using the locating hole as a center point. (Cover any exposed open vent pipes before cutting hole in roof.) The 10"x10" hole must be measured on the horizontal; actual length may be larger depending on the pitch of the roof. There must be a 1" clearance from the vent pipe to combustible materials. Frame the opening as shown in Figure 17 on page 9.

If area above is a room, install firestop above framed hole.



If area above is not a room, install firestop below framed hole.

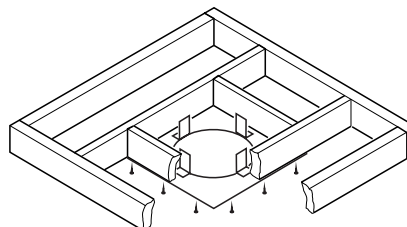

Figure 25 - Installing Firestop

4. Connect a section of pipe and extend up through the hole.

Note: If an offset is needed to avoid obstructions, you must support the vent pipe every 3 feet. Use wall straps for this purpose (see Figure 24). Whenever possible, use 45° elbows instead of 90° elbows. The 45° elbow offers less restriction to the flow of the flue gases and intake air.

5. Place the flashing over the pipe section(s) extending through the roof. Secure the base of the flashing to the roof and framing with roofing nails. Be sure roofing material overlaps the top edge of the flashing as shown in Figure 24. There must be a 1" clearance from the vent pipe to combustible materials.
6. Continue to add pipe sections until the height of the vent cap meets the minimum building code requirements described in Figure 13 on page 6. *Note:* You must increase vent height for steep roof pitches. Nearby trees, adjoining rooflines, steep pitched roofs, and other similar factors may cause poor draft or down-drafting in high winds. Increasing the vent height may solve this problem.
7. Twist-lock the vent cap onto the last section of vent pipe and seal with high temperature silicone sealant as specified in the second warning statement on page 7.

Note: If the vent pipe passes through any occupied areas above the first floor, including storage spaces and closets, you must enclose pipe. You may frame and sheetrock the enclosure with standard construction material. Make sure and meet the minimum allowable clearances to combustibles. Do not fill any of the required air spaces with insulation.

Cathedral Ceiling Installation

1. Remove shingles or other roof covering as necessary to cut the rectangular hole for the support box. Mark the outline of the cathedral ceiling support box on the roof sheathing using the locating hole as a center point.
2. Cut the hole 1/8" larger than the support box outline (see Figure 26, page 13).

VENTING INSTALLATION *Continued*

- Lower the support box through the hole in the roof until the bottom of the box extends at least 2" below the ceiling (see Figure 26). Align the support box vertically and horizontally using a level. Temporarily tack the support box in place through the inside walls and into the roof sheathing.
- Using tin snips, cut the support box from the top corners down to the roofline and fold the resulting flaps over the roof sheathing (see Figure 27). Apply a bead of non-hardening mastic around the top edges of the support box to make a seal between the box and the roof. Nail in place with roofing nails. Remove any combustible material that might be inside of the support box.
- Complete the cathedral ceiling installation by following the same procedures outlined in steps 2 through 7 for *Flat Ceiling Installation*, page 12.

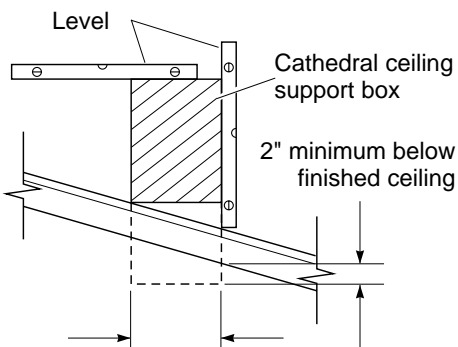

Cut hole 1/8" larger than support box when projected onto roofline

Figure 26 - Cathedral Ceiling Support Box Installation

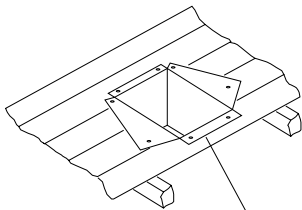

Non-hardening Mastic under all edges of support box before nailing

Figure 27 - Installed Cathedral Ceiling Support Box

Vertical Termination Configurations

Figures 28 through 31 show four different configurations for vertical termination. All connections must be sealed with high temperature silicone sealant as specified in the second warning statement on page 7.

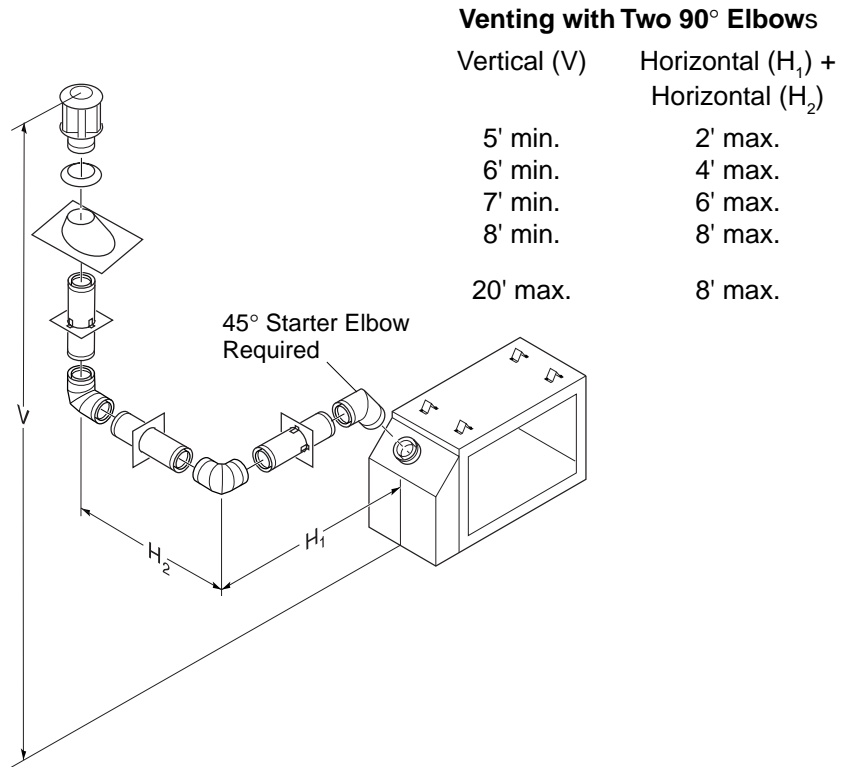

Figure 28 - Vertical Rigid Venting Configuration Using Two 90° Elbows with Two Horizontal Runs

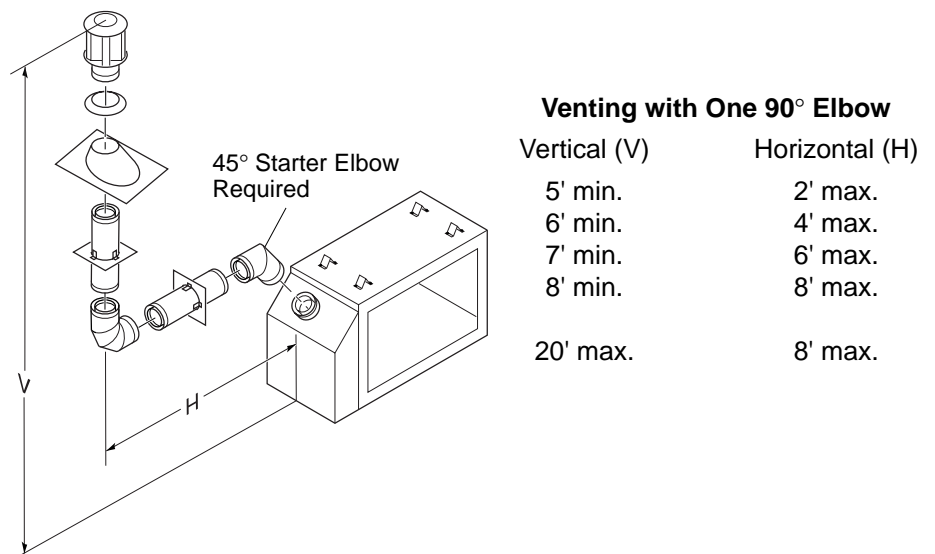
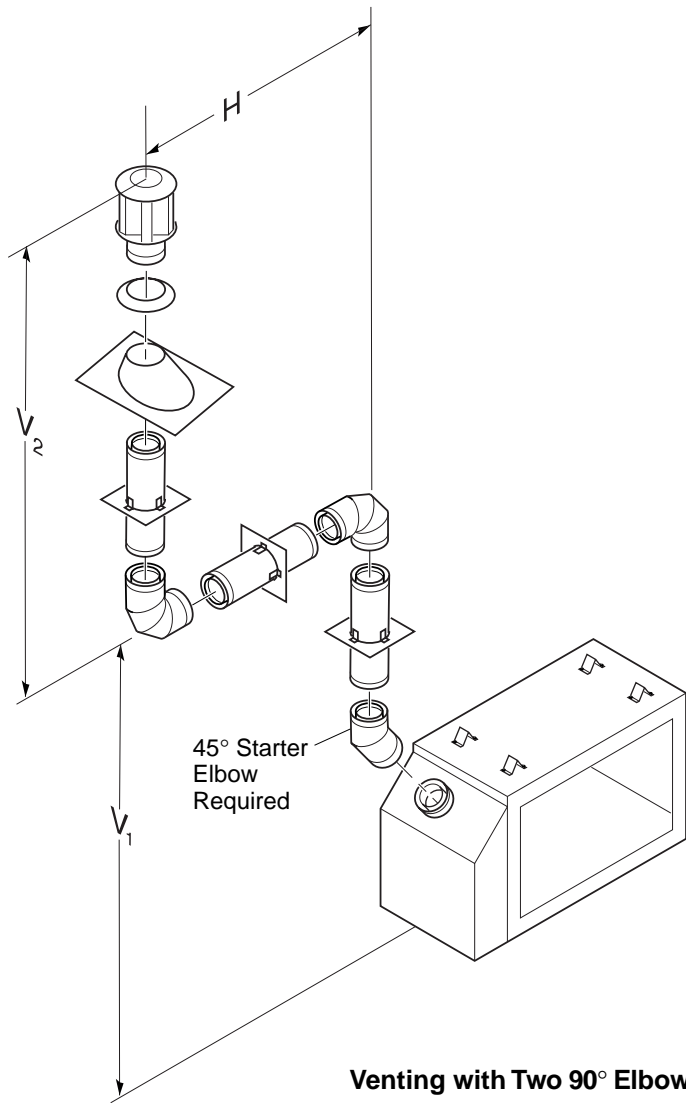

Figure 29 - Vertical Rigid Venting Configuration Using One 90° Elbow

Continued

VANGUARD® VDV36P and VDV36ST Series DIRECT-VENT GAS FIREPLACE HEATER

VENTING INSTALLATION *Continued*



Venting with Two 90° Elbows

Vertical (V_1)	Horizontal (H)
5' min.	6' max.
6' min.	12' max.
7' min.	18' max.
8' min.	20' max.

Note: Vertical (V_1) +
Vertical (V_2) = 20' max.

Figure 30 - Vertical Rigid Venting Configuration Using Two 90° Elbows

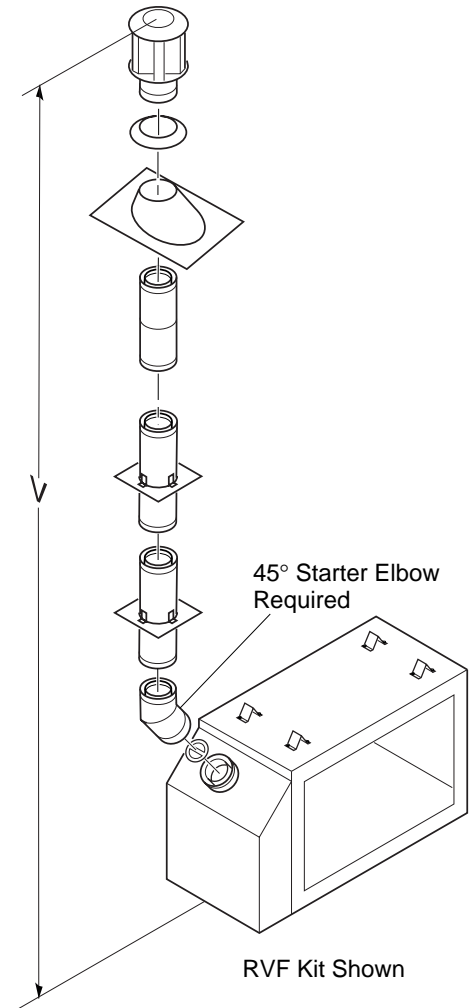

Vertical Venting

$V = 30'$ max.

Figure 31 - Vertical Rigid Venting Configuration With No Horizontal Run

OWNER'S MANUAL

VENTING INSTALLATION *Continued*

HIGH ALTITUDE INSTALLATION

Your Vanguard direct-vent fireplace has been AGA tested and approved for elevations from 0-2000 feet and CGA certified for elevations from 0-4500 feet.

When installing this fireplace at an elevation above 2000 feet (in the USA), you may need to decrease the input rating by changing the existing burner orifice to a smaller size. Reduce input 4% for each 1000 feet above sea level. Check with your local gas company for proper orifice size identification.

When installing this fireplace at an elevation above 4500 feet (in Canada), check with local authorities.

Consult your local gas company to help determine the proper orifice for your location.

For assistance with any high altitude installation contact DESA International's Technical Service Department at 1-800-DESA-LOG (1-800-337-2564).

PARTS LISTS FOR VENTING KITS AND COMPONENTS

***NOTICE: The 7" x 30° Elbow supplied with kits CVK, BVK, SVK, and RVF cannot be used. It MUST be replaced with a 7" x 45° Starter Elbow (D2060).**

Vanguard Rigid Venting

Number	Description
*CVK	Corner Vent Kit Includes: 7" x 30° Elbow, 7" x 90° Elbow, 7" Adjustable Galvanized Pipe (7-12"), 6" Pipe, Wall Thimble, Horizontal Termination, RTV Silicone and 20 Screws
*BVK	Basement Rigid Vent Kit Includes: 7" x 30° Elbow, 7" x 4' Galvanized Pipe, 7" x 90° Elbow, 7" Adjustable Galvanized Pipe (7-12"), Wall Thimble, Horizontal Termination, RTV Silicone and 20 Screws

Vanguard Rigid Venting (Cont.)

Number	Description
*SVK	Snorkel Rigid Vent Kit Includes: 7" x 30° Elbow, 7" x 4' Galvanized Pipe, 7" x 90° Elbow, 7" Adjustable Galvanized Pipe (7-12"), Wall Thimble, 36" Snorkel Termination, RTV Silicone and 28 Screws
*RVF	Roof Rigid Vent Kit Includes: Flue Restrictor, Storm Collar, 7" x 30° Elbow, 7" x 4' Galvanized Pipe, 7" x 2' Galvanized Pipe, 7" Adjustable Galvanized Pipe (7-12"), Firestop Support, Roof Flashing, RTV Silicone, Vertical Termination, and 26 screws
D1000	7" x 12" Galvanized Coaxial Pipe (6 pcs.)
D1010	7" x 24" Galvanized Coaxial Pipe (6 pcs.)
D1020	7" x 48" Galvanized Coaxial Pipe (6 pcs.)
D1030	7" Adjustable (7-12") Galvanized Coaxial Pipe (6 pcs.)
D1050	7" x 6" Galvanized Coaxial Pipe (6 pcs.)
D2000	7" x 90° Elbow (6 pcs.)
D2010	7" x 45° Elbow (6 pcs.)
D2060	7" x 45° Starter Elbow
D3000	Wall Strap/Offset Support (6 pcs.)
D3010	Storm Collar (6 pcs.)
D3020	Wall Thimble (6 pcs.)
D3050	Vertical Restrictor (6 pcs.)
D3060	Ceiling Firestop/Support (6 pcs.)
D3070	Rectangular Horizontal Rigid Vent Termination Cap
D3090	Cathedral Ceiling Support Box
D4000	Roof Flashing 6/12-9/12
D4010	Roof Flashing 9/12-12/12
D4020	Flex Connector (6 pcs.)
D4030	Flex Wall Thimble (6 pcs.)
D4040	4" Hose Clamp (6 pcs.)
D4050	7" Hose Clamp (6 pcs.)
D5000	Vinyl Siding Standoff (6 pcs.)

Vanguard Flexible Venting

Number	Description
FGFVK	Flex Ground Floor Vent Kit Includes: Flex Adapter, 7" x 4' Flexible Pipe, 4" x 4' Flexible Pipe, Wall Thimble, Horizontal Termination, (4) Spacer Springs, (2) 4" Hose Clamps, (2) 7" Hose Clamps, RTV Silicone, and 10 Screws
D1040	7" x 25' Coaxial Flex Pipe with Spacer Springs
D3080	Rectangular Horizontal Flex Termination Cap

SIMPSON DURA-VENT GS 4" x 6 5/8"

Number	Description
902	7" x 48" Pipe
903	7" x 36" Pipe
904	7" x 24" Pipe
906	7" x 12" Pipe
907	7" x 9" Pipe
908	7" x 6" Pipe
911	7" Adjustable (11"-14 5/8") Pipe
940	Wall Thimble
941	Cathedral Ceiling Support Box
943	Roof Flashing 0/12-6/12
943S	Roof Flashing 7/12-12/12
945	7" x 45° Elbow
950	Vinyl Siding Standoff
953	Storm Collar
963	Ceiling Firestop
981	36" Snorkel Termination
984	Horizontal Termination Vent Cap
988	Wall Strap
990	7" x 90° Elbow
991	Vertical High Wind Termination

VANGUARD® VDV F36P and VDV F36ST Series DIRECT-VENT GAS FIREPLACE HEATER

INSTALLATION

WALL SWITCH INSTALLATION

Since the VDV F36 series models use a valve that operates on millivolt current generated by the pilot, a wall switch may be used to activate the gas control valve without the use of normal household electricity.

1. To remove the louvers, simultaneously pull both top end spring latches towards the center of the appliance until they are disengaged from locating holes. Repeat for bottom end spring latches and pull outward. Reverse the procedure to install louvers back onto the appliance (see Figure 32).
2. Connect the 18 ga. wires from wall switch to the gas control valve and microswitch, as shown in Figure 33.

WARNING: Do not wire remote wall switch to main power supply (Standard 120v household current).

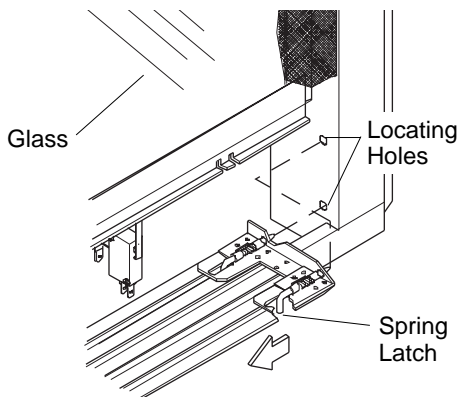

Figure 32 - Removing Louver

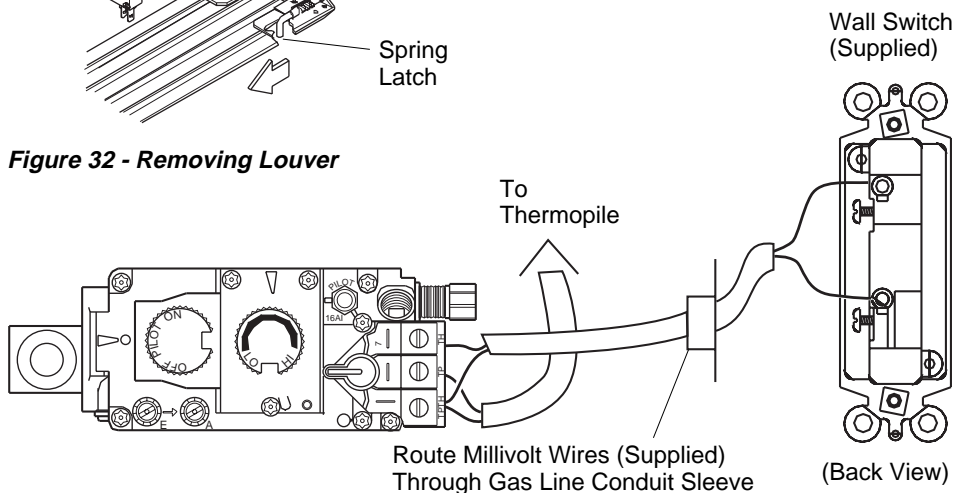

Figure 33 - Wall Switch Wiring Diagram

Note: If any of the original wire supplied must be replaced, use type 18 AWG-105 degree C (25 feet length MAXIMUM) or equivalent.

ELECTRICAL HOOKUP FOR BLOWER ACCESSORY

Before blower accessory can be operated, it must be properly connected to a standard 120 VAC power source. Refer to *Wiring Diagram* on page 23.

An outlet box with two receptacles has been supplied for your convenience, located on the lower left side of the appliance (see Figure 34). An optional remote control may be installed at any time.

CAUTION: Due to high temperatures, make sure no wires are touching the bottom of the firebox.

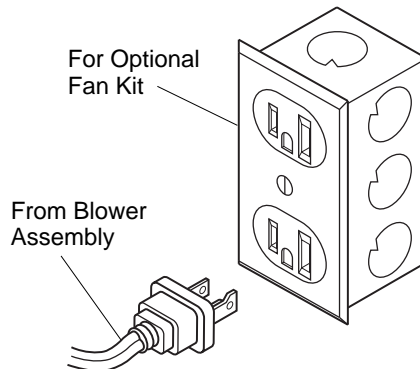

Figure 34 - Connecting Blower Accessory to Power Supply

OPTIONAL WIRELESS HAND-HELD REMOTE CONTROL (GHRC(T) SERIES) INSTALLATION

Note: If using an optional wireless hand-held remote control, the wall switch is no longer operational.

NOTICE: Only use alkaline batteries (not included).

Installing Receiver

1. Remove access panel from lower front face of firebox. Lift straight up on access panel until it stops. Pull bottom of access panel forward, then down.
2. Disconnect wall switch wires from TH and TPTH terminals on control valve (see Figure 33).
3. Install remote receiver unit onto mounting bracket using the two plastic mounting clips (see Figure 35).
4. Connect wires to control valve. Connect white wire to terminal TH. Connect red wire to terminal TPTH.
5. Locate the battery clip mounted on the back of the receiver (see Figure 36).
6. Slide 9-volt battery (not included) through the clip.
7. Attach the terminal wires to the battery (see Figure 36).
8. Replace access panel. Place top of access panel into opening and slide up. Push bottom of access panel in and slide down to install.

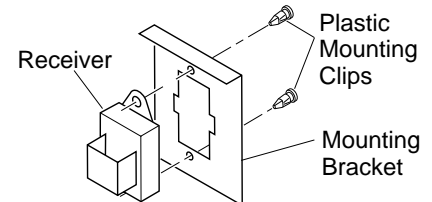

Figure 35 - Installing Remote Receiver (Shown from Rear of Mounting Bracket)

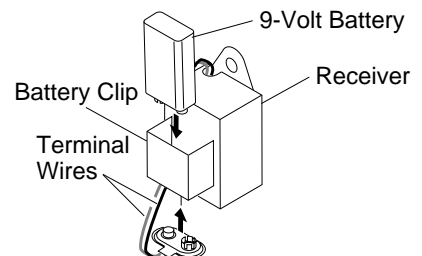

Figure 36 - Installing Battery in Receiver

INSTALLATION

Continued

Installing 9-Volt Alkaline Battery in Hand-Held Remote Control Unit

1. Remove battery cover on back of remote control unit.
2. Attach terminal wires to the battery (not included). Place battery into the battery housing.
3. Replace battery cover onto remote control unit.

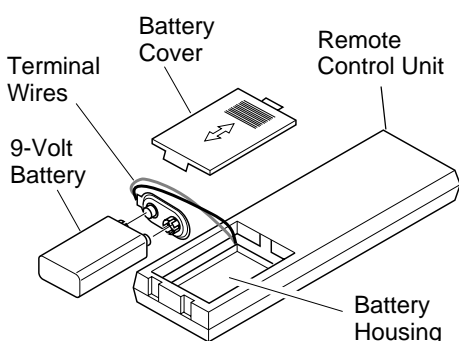

Figure 37 - Installing Battery in Hand-Held Remote Control Unit

GAS LINE HOOK-UP

WARNING: Before you proceed, make sure your gas supply is OFF.

WARNING: Gas line hookup should be done by your gas supplier or a qualified service person.

A manual shut-off valve has been included in the appliance's gas supply system. You may consider installing an extra gas shut-off valve outside the appliance's enclosure (check with local codes) where it can be accessed more conveniently with a key through a wall as shown in Figure 38.

Route a 1/2" NPT black iron gas line towards the appliance coming in from the left. It is recommended to route the pipe between the stand of the firebox and the surround of the fireplace (see Figure 39).

IMPORTANT: The appliance and its individual shut-off valve must be disconnected from the gas supply piping system during any pressure testing of that system at test

pressures in excess of 1/2 psig. (3.5 kPa). The appliance must be isolated from the gas supply piping system by closing its individual manual shut-off valve during any pressure testing of the gas supply piping system at test pressures equal to or less than 1/2 psig. (3.5 kPa).

CAUTION: Do not kink flexible gas line.

CAUTION: Compounds used on threaded joints of gas piping shall be resistant to the action of Liquefied Petroleum (LP or propane), and should be applied lightly to ensure excess sealant does not enter the gas line.

1. Install a sediment trap between the incoming gas line and the gas control valve (see Figure 39). The sediment trap should extend down the center of the pipe. Refer to your local codes.
2. Prepare incoming gas line and check with local codes regarding the use of teflon tape. Complete your gas line in-

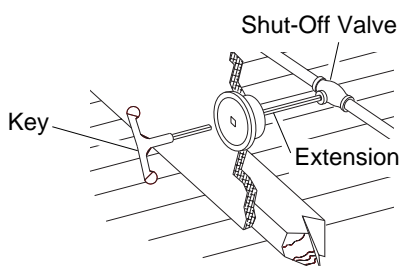

Figure 38 - Typical Exterior Wall Gas Shut-Off Installation

stallation by connecting incoming gas line with flexible gas line. Secure tightly with a wrench, but **Do NOT Overtighten.**

WARNING: All gas piping and connections must be tested for leaks after the installation is completed.

After ensuring that the gas valve is open, apply a soap and water solution to all connections and joints. If bubbles appear, leaks can be detected and corrected.

Do not use an open flame for leak testing and do not operate any appliance if a leak is detected.

WARNING: Improper installation, adjustment, alteration, service, or maintenance can cause injury or property damage. Refer to this manual. For assistance or additional information, consult a qualified installer, service agency, or gas supplier.

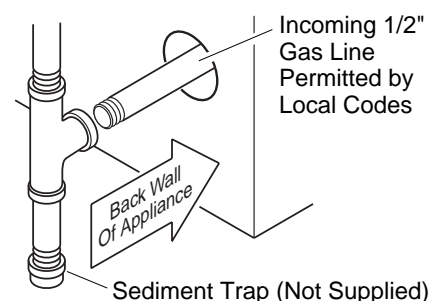

Figure 39 - Sediment Trap

GAS RATING		
TYPE OF GAS	NATURAL	PROPANE/LP
Max. Input Rating:	30,000 Btu/hr	28,000 Btu/hr
Orifice Size (0-4,500 Ft.):	7/64"	#52
Minimum Input Rating: (When the Valve is in the LOW Position)	21,000 Btu/hr	20,000 Btu/hr
* Maximum Output Rating:	21,000 Btu/hr	20,000 Btu/hr
Manifold Pressure:	3.5 in. WC	10.0 in. WC
**Minimum Supply Pressure:	4.5 in. WC	11.0 in. WC
**Maximum Supply Pressure:	10.5 in. WC	13.0 in. WC

* 70% Efficiency (flue loss calculation).

** For the purpose of input adjustment.

Continued

VANGUARD® VDVVF36P and VDVVF36ST Series DIRECT-VENT GAS FIREPLACE HEATER

INSTALLATION

Continued

GAS SUPPLY TESTING

Note: This section is intended as a guide for qualified service technicians installing gas to the appliance.

⚠ CAUTION: Do not connect appliance before pressure testing gas piping. Damage to the gas valve may result and an unsafe condition may be caused.

The millivolt system with a manual HI/LO applies only to the VDVVF36STN/STP and VDVVF36PN/PP models. The gas control valve is secured underneath the firebox with two brackets fastened to the firebox bottom. Two pressure taps are provided on the gas control valve for a pressure gauge connection (see Figure 40).

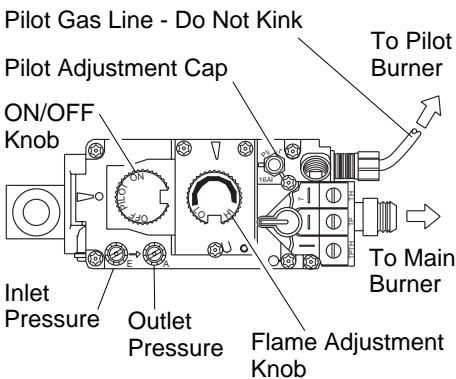

Figure 40 - Millivolt Control Valve

INSTALLING LOG SET

Before proceeding, make sure the gas control valve is in the “OFF” position. Logs have been packaged separately to prevent damage to glass or refractory.

1. Remove top and bottom louvers by simultaneously pulling both top end spring latches towards the center of the appliance until they are disengaged from locating holes. Repeat for bottom end spring latches and pull outward. Reverse procedure to install louvers back.
2. Remove the screen rod by sliding spring clip on one end toward the center. Slide rod into screen rod hole until other end of rod is free. Remove rod.
3. To open the glass door, open the pairs of latches located on the top and bottom of the firebox (see Figure 41). *Note:* Use caution when opening these latches.
4. Carefully open the door. The glass door is mounted to the firebox with 5 screws.
5. To remove the logs from the shrink wrap, carefully cut the plastic around the perimeter of the log. Do not try to remove the logs from the package without first cutting the plastic.
6. Figure 42 shows the log set. Logs “A” have the knot at the end of the log. Logs “B” have the knot at the middle of the log. Twigs “C” have the shape of a “Y”. Twigs “D” have the shape of bent twigs. Twig “E” is a straight twig which is placed across the top of Logs “B”.

7. Figure 43, page 19, shows the top view of the burner and grate.
8. Place logs “A” as shown in Figure 44, page 19.
9. Place logs “B” as shown in Figure 45, page 19. Lift the end of log “A” that will be propped up and place log “B” under it. At the same time, the other side of log “B” is placed over the other log “A”. Repeat procedure for the other log “B”.
10. Take twigs “C” (shaped like a “Y”) and place them as shown in Figure 46, page 19.
11. Take twigs “D” (bent twig) and place them as shown in Figure 46, page 19.
12. Place twig “E” across the top of logs “B” as shown in Figure 46, page 19.
13. When finished installing the logs, close the glass doors while making certain that the safety door switch is fully depressed by the door frame before securing the four (4) spring loaded latches.
14. Replace the louvers in reverse order with the grilles pointing in the down position.

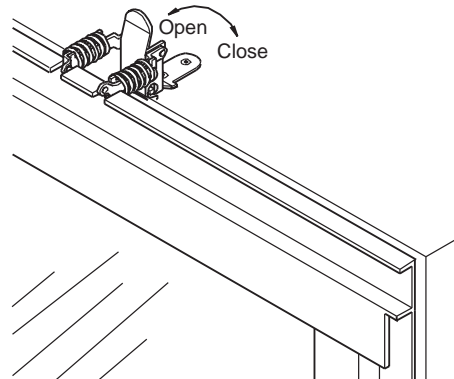

Figure 41 - Removing Glass Door

INSTALLATION

Continued

⚠ WARNING: Improper installation, adjustment, alteration, service, or maintenance can cause injury or property damage. Refer to this manual. For assistance or additional information, consult a qualified installer, service agency, or gas supplier.

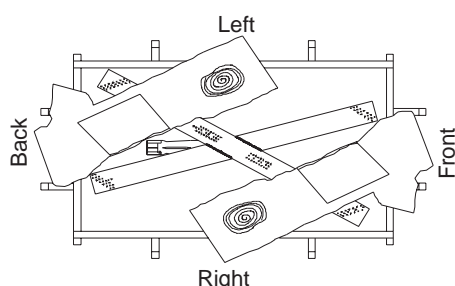

Figure 44 - Installing Logs "A" (Top View)

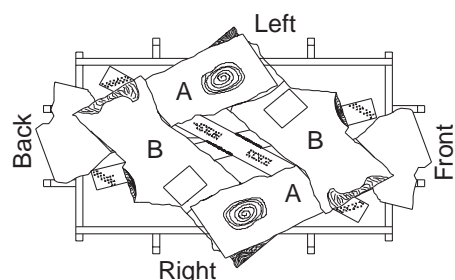

Figure 45 - Installing Logs "B" (Top View)

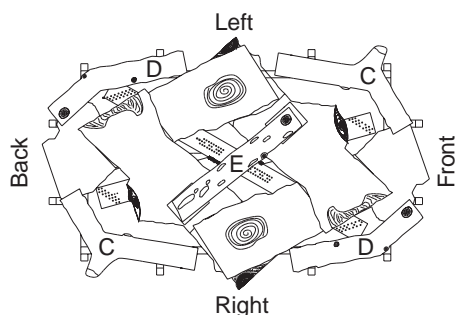

Figure 46 - Installing Twigs "C, D, E" (Top View)

DECORATIVE FACING

Any noncombustible material may be used for facing (glass, tile, brick, etc.) as long as the proper clearances are observed (see *Clearances*, page 4). **IMPORTANT:** Louvered openings must not be obstructed, and upper and lower panels must remain removable for servicing. Use only heat-resistant, noncombustible mortar or adhesive when securing facing material.

Note: Combustible material, such as wood, that has been fireproofed is not considered noncombustible.

PILOT ASSEMBLY ADJUSTMENT

The pilot assembly is factory preset for the proper flame height. Alteration to these settings may have occurred during shipping and handling. If this is the case, some minor adjustment may be necessary and should be done by a qualified technician. To access the pilot assembly, the glass door must be opened. The proper settings for the thermopile height should be at a distance of 3/8" to 1/2" from the pilot flame as shown in Figure 47.

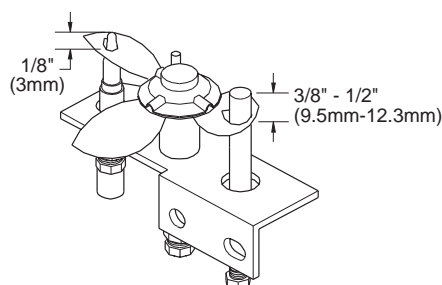

Figure 47 - Correct Pilot Flame Pattern

BURNER FLAME ADJUSTMENT

The air shutter, located at the underside of the main burner (see Figure 48), has been factory preset to the proper air-to-gas ratio which results in an even, clean burning flame across the burner (see Figure 49). If readjustment is necessary, you can restore the proper air-to-gas ratio by loosening the air shutter screw and rotating the air shutter until the proper flame setting is achieved (the shutter's normal setting is "full opened"). Do not forget to retighten the air shutter screws.

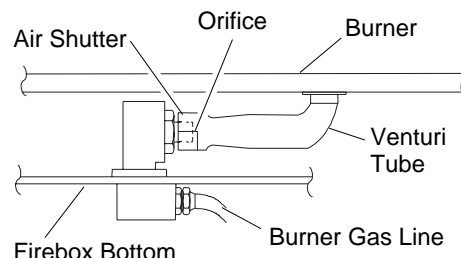

Figure 48 - Connecting Venturi and Orifice

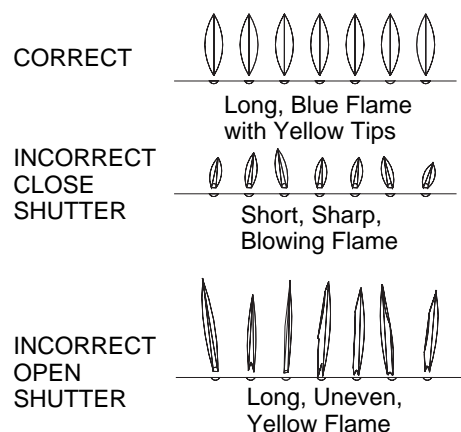

Figure 49 - Burner Flame Patterns

BURNER REMOVAL

⚠ CAUTION: Before proceeding, make sure the entire unit is cool.

1. Remove the top and bottom louvers and screen. Open the glass door (left or right side).
2. Carefully remove the log set.
3. Remove the screw that attaches the burner to the bracket.
4. Slide the burner towards the front of the unit, lift, and remove from the firebox.
5. To reinstall the burner, slide the burner towards the rear of the unit and secure burner to bracket with screw.

⚠ CAUTION: Make certain the orifice is inside the venturi tube's air shutter, see Figure 48.

6. Replace the log set, close door with latches, and attach screen and louvers.

VANGUARD® VDVVF36P and VDVVF36ST Series DIRECT-VENT GAS FIREPLACE HEATER

OPERATING GUIDELINES AND MAINTENANCE INSTRUCTIONS

When lit for the first time, the appliance may emit a slight odor for about 16 - 24 hours. This is normal and is due to the “curing” of the logs and the “burn-in” of internal paints and lubricants used in the manufacturing process. Keep compartments, logs, burners, and area surrounding the logs clean by vacuuming or brushing at least twice a year. Temporary removal of the log set may ease the cleaning of the burner and pilot assembly. In cleaning, take care not to alter the pilot or burner location. Be sure appliance is cool before each maintenance session.

⚠ CAUTION: The appliance and logs can get very hot - Handle only when cool.

⚠ WARNING: Turn off gas and wall switch before servicing appliance. Any safety screen or guard removed for servicing the appliance must be replaced prior to operating the appliance.

Any household glass cleaner may be used to clean the glass panel. Do not use abrasive cleaners as this may damage the glass. **Clean glass only when cool.**

⚠ WARNING: Do not operate appliance with panel(s) and glass removed, cracked, or broken. Replacement of the panel(s) should be done by a licensed, qualified service person.

⚠ WARNING: Make certain wires and gas lines are not touching the underside of the firebox.

⚠ CAUTION: If the glass breaks, be cautious of fragments on the floor. Keep children away from the area. Do not operate the unit. Use proper safety gloves to remove the broken glass door. Discard safely. A glass door kit can be ordered through your local distributor. Do not substitute other material for the glass.

⚠ WARNING: Children and adults should be alerted to the hazards of high surface temperatures, and to stay away from the appliance to avoid burns or clothing ignition. Young children should be carefully supervised when they are in the same room as the appliance.

⚠ WARNING: Have a qualified agency periodically inspect the vent system at the start of each heating season, for any obstruction which may hinder its normal operation. Never obstruct the flow of combustion and ventilation air. Keep the front of the appliance clear of all obstacles and materials.

⚠ WARNING: Do not abuse, strike, or slam the glass doors.

⚠ CAUTION: Label all wires prior to disconnection when servicing controls. Wiring errors can cause improper and dangerous operation.

For further operating guidelines, contact your authorized dealer.

OPERATING FIREPLACE

FOR YOUR SAFETY READ BEFORE LIGHTING

⚠ WARNING: If you do not follow these instructions exactly, a fire or explosion may result causing property damage, personal injury or loss of life.

- A. This appliance has a pilot which must be lighted by hand. When lighting the pilot, follow these instructions exactly.
- B. **BEFORE LIGHTING** smell all around the appliance area for gas. Be sure to smell next to the floor because some gas is heavier than air and will settle on the floor.

WHAT TO DO IF YOU SMELL GAS

- Do not try to light any appliance.
 - Do not touch any electric switch; do not use any phone in your building.
 - Immediately call your gas supplier from a neighbor's phone. Follow the gas supplier's instructions.
 - If you cannot reach your gas supplier, call the fire department.
- C. Use only your hand to push in or turn the gas control knob. Never use tools. If the knob will not push in or turn by hand, don't try to repair it, call a qualified service technician or gas supplier. Force or attempted repair may result in a fire or explosion.
 - D. Do not use this appliance if any part has been under water. Immediately call a qualified service technician to inspect the appliance and to replace any part of the control system and any gas control which has been under water.

LIGHTING INSTRUCTIONS

1. **STOP!** Read the safety information above on this label before proceeding.
2. Set the "HI-LO" knob to the lowest setting.
3. Turn off all electrical power to the appliance.
4. Open control access panel.
5. Push in gas control knob slightly and turn clockwise to "OFF".
6. Wait five (5) minutes to clear out any gas. Then smell for gas, including near the floor. If you smell gas, **STOP!** Follow "B" in the safety information on this page. If you don't smell gas, go to the next step.
7. The pilot is located by the main burner.
8. Turn knob on gas control counterclockwise to "PILOT".
9. Push in the control knob all the way and hold in. Immediately light the pilot by pressing the ignitor button until a flame appears one (1) minute after the pilot is lit. Release knob and it will pop back up. Pilot should remain lit. If it goes out, repeat steps 5 through 9.
 - If knob does not pop out when released, stop and call gas supplier.
 - If the pilot will not stay lit after several tries, turn gas control knob to "OFF" and call your service technician or gas supplier.
10. Turn gas control knob counterclockwise to "ON". Knob can be turned to "ON" only if the control knob is popped out.
11. Set "HI-LO" knob to desired setting.
12. Turn on all electric power to the appliance.

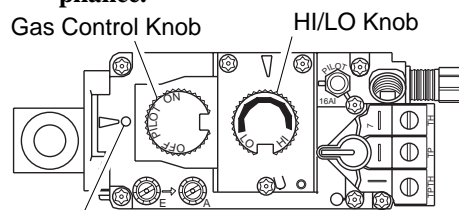

Position Indicator

Figure 50 - Control Knob in the PILOT Position

TO TURN OFF GAS TO APPLIANCE

1. Turn off the wall switch.
2. Turn off all electric power to the appliance if service is to be performed.
3. Remove control access panel.
4. Push in gas control knob slightly and turn clockwise to "OFF". Do not force.
5. Replace control access panel.

OPTIONAL REMOTE OPERATION

Note: All remote control accessories must be purchased separately (see *Accessories*, page 28). Follow instructions included with the remote control.

Thermostat Control Operation

(Optional GHRCT Only) The thermostat control setting on the remote control unit can be set to any comfort level between HI and LO. The burners will turn on and off automatically to maintain the comfort level you select. The ideal comfort setting will vary by household depending upon the amount of space to be heated, the output of the central heating system, etc.

NOTICE: You must light the pilot before using the hand-held remote control unit. See *Lighting Instructions*, column 2.

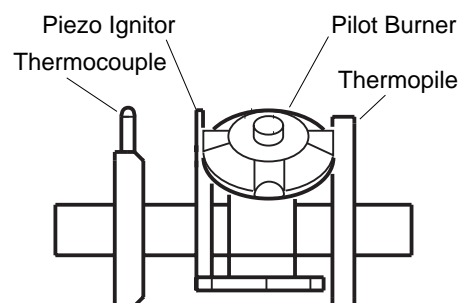

Figure 51 - Pilot

VANGUARD® VDV F36P and VDV F36ST Series DIRECT-VENT GAS FIREPLACE HEATER

OPERATING FIREPLACE *Continued*

1. After lighting, let pilot flame burn for about one minute. Turn control knob to ON position. Adjust flame adjustment knob anywhere between HI and LO. Slide the selector switch to the REMOTE position. **Note:** The burners may light if hand-held remote ON button was on when selector switch was last turned off. You can now turn the burners on and off with the hand-held remote control unit.

IMPORTANT: Do not leave the selector switch in the REMOTE position when the pilot is not lit. This will drain the battery.

IMPORTANT: Be sure to press the ON/OFF buttons on the hand-held remote control unit for up to 3 seconds to assure proper operation.

GHRC Operation:

- 2a. Press ON/OFF button to turn the burners on and off. When turning burners off, the pilot will remain lit.

GHRCT Operation:

- 2b. Select the MAN (manual) or AUTO button on the hand-held remote control unit (see Figure 53).
 - In manual mode, turn burners on or off by pressing the ON or OFF buttons on the hand-held remote control unit.
 - In auto mode, the room temperature is controlled by the thermostat in the hand-held remote control unit. To increase the room temperature, press the top arrow of the TEMP button. To lower the room temperature, press the bottom arrow of the TEMP button. At higher settings the heater will run longer. **IMPORTANT:** This remote control has been specially engineered to take an air temperature sample every 5.5 minutes in the auto mode. It will not respond immediately to the temperature setting being turned up or down.

IMPORTANT: The hand-held remote control unit must be near the heater. Do not keep the hand-held remote control unit too close to the heater. The thermostat on the hand-held remote control unit will heat up too quickly and turn the heater off.

3. Use the STATUS button on the hand-held remote control unit to see the operation mode being used and the temperature setting selected. A red light will come on beside the operation mode being used when the status button is pressed.
4. To turn the burners off when operating in the manual mode, press the OFF button. If operating in the auto mode, press the MAN button, then press the OFF button. The pilot will remain lit. **IMPORTANT:** To turn the pilot off, manually turn the control knob on the heater to the OFF position.

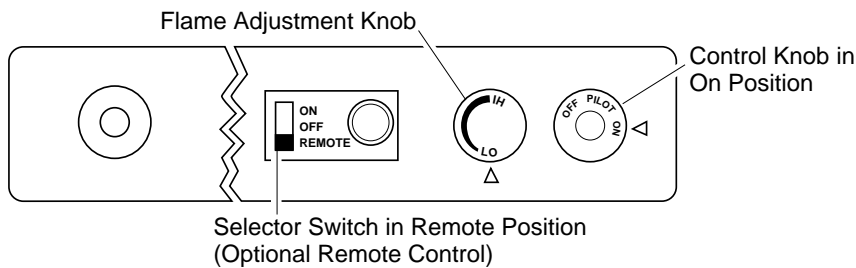

Figure 52 - Setting the Selector Switch, Control Knob, and Flame Adjustment Knob for Remote Operation

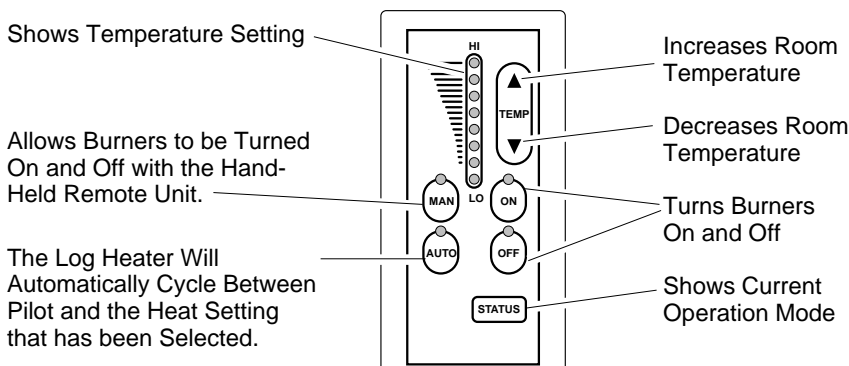

Figure 53 - Thermostat Hand-Held Remote Control Unit Selections (GHRCT only)

OWNER'S MANUAL

SERVICE HINTS

When Gas Pressure Is Too Low

- pilot will not stay lit
- burner will have delayed ignition
- fireplace will not produce specified heat
- propane/LP gas supply may be low

When Gas Quality Is Bad

- pilot will not stay lit
- burner will produce flames and soot
- fireplace will backfire when lit

You may feel your gas pressure is too low or gas quality is bad. If so, contact your local propane/LP gas supplier.

WIRING DIAGRAM

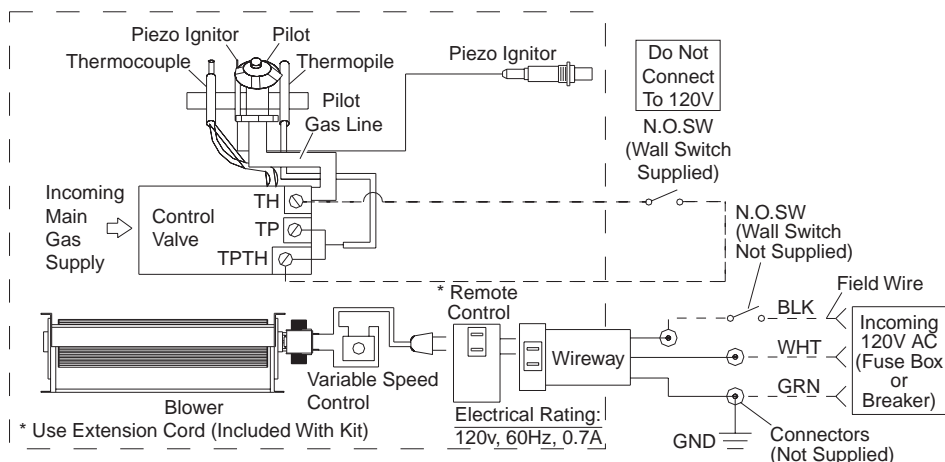

TECHNICAL SERVICE

You may have further questions about installation, operation, or troubleshooting. If so, contact DESA International's Technical Service Department at 1-800-323-5190.

You can also visit DESA International's Technical Services web site at www.desatech.com.

REPLACEMENT PARTS

Note: Use only original replacement parts. This will protect your warranty coverage for parts replaced under warranty.

PARTS UNDER WARRANTY

Contact authorized dealers of this product. If they can't supply original replacement part(s) call DESA International's Technical Service Department at 1-800-323-5190 for referral information.

When calling DESA International, have ready

- your name
- your address
- model and serial numbers of your fireplace
- how fireplace was malfunctioning
- type of gas used (propane/LP or natural gas)
- purchase date

Usually, we will ask you to return the defective part to the factory.

PARTS NOT UNDER WARRANTY

Contact authorized dealers of this product. If they can't supply original replacement part(s) call DESA International's Parts Department at 1-800-972-7879 for referral information.

When calling DESA International, have ready

- model number of your fireplace
- the replacement part number

VANGUARD® VDVF36P and VDVF36ST Series DIRECT-VENT GAS FIREPLACE HEATER

TROUBLESHOOTING

Note: For additional help, visit DESA International's Technical Service web site at www.desatech.com.

⚠ WARNING: Turn off heater and let cool before servicing. Only a qualified service person should service and repair heater.

⚠ CAUTION: Never use a wire, needle, or similar object to clean pilot. This can damage pilot unit.

Note: Before troubleshooting the system, make sure the gas shut-off valve is ON.

Note: All troubleshooting items are listed in order of operation.

OBSERVED PROBLEM	POSSIBLE CAUSE	REMEDY
Pilot will not light	<ol style="list-style-type: none"> 1. No gas supply, or shut-off valve is OFF 2. Air in gas line 3. Construction debris clogging pilot orifice 4. Low gas pressure 5. Control valve knob is not on the PILOT position 6. Kinked pilot line 7. Bad valve 8. Bad thermocouple or loose connection 	<ol style="list-style-type: none"> 1. Check to see if you have gas supply 2. Hold control valve in the PILOT position for 2 to 3 minutes to purge air. If you smell gas stop and wait for a few minutes before trying to light the fireplace 3. Remove debris and dirt, inspect and clean any other possible obstructions 4. Contact your gas supplier 5. Refer to section on pilot lighting 6. Have a qualified technician replace pilot line 7. Replace control valve (see <i>Replacement Parts</i>, page 23) 8. Tighten thermocouple or replace
No gas to burner, although wall switch and valve are set to the ON position	<ol style="list-style-type: none"> 1. Wall switch wires defective 	<ol style="list-style-type: none"> 1. Check electrical connections
Frequent pilot outage	<ol style="list-style-type: none"> 1. Pilot flame may be too low, causing safety pilot to "drop out" 	<ol style="list-style-type: none"> 1. Clean and adjust pilot flame for maximum flame impingement on thermopile
Burner goes off after a short time	<ol style="list-style-type: none"> 1. Venting recirculation problem 	<ol style="list-style-type: none"> 1. Have a qualified technician check venting system for leaks or obstructions. Have a qualified technician measure the pilot's millivoltage

OWNER'S MANUAL

TROUBLESHOOTING

Continued

OBSERVED PROBLEM	POSSIBLE CAUSE	REMEDY
When ignitor button is pressed, there is no spark at pilot	<ol style="list-style-type: none">1. Ignitor electrode not connected to ignitor cable2. Ignitor cable pinched or wet3. Piezo ignitor nut is loose4. Broken ignitor cable5. Bad piezo ignitor6. Ignitor electrode broken7. Ignitor electrode positioned wrong	<ol style="list-style-type: none">1. Reconnect ignitor cable2. Free ignitor cable if pinched by any metal or tubing. Keep ignitor cable dry3. Tighten nut holding piezo ignitor. Nut is located behind the mounting bracket4. Replace ignitor cable5. Replace piezo ignitor6. Replace pilot assembly7. Replace pilot assembly
When ignitor button is pressed, there is spark at pilot but no ignition	<ol style="list-style-type: none">1. Gas supply turned off or manual shutoff valve closed2. Control knob not in PILOT position3. Control knob not pressed in while in PILOT position4. Air in gas lines when installed5. Depleted gas supply (propane/LP models only)6. Pilot is clogged7. Gas regulator setting is not correct	<ol style="list-style-type: none">1. Turn on gas supply or open manual shutoff valve2. Turn control knob to PILOT position3. Press in control knob while in PILOT position4. Continue holding down control knob. Repeat igniting operation until air is removed5. Contact local propane/LP gas company6. Clean pilot or replace pilot assembly7. Replace gas control
Pilot lights but flame goes out when control knob is released	<ol style="list-style-type: none">1. Control knob not fully pressed in2. Control knob not pressed in long enough3. Manual shutoff valve not fully open4. Pilot flame not touching thermocouple, which allows thermocouple to cool, causing pilot flame to go out. This problem could be caused by one or both of the following:<ol style="list-style-type: none">A) Low gas pressureB) Dirty or partially clogged pilot5. Thermocouple connection loose at control valve6. Thermocouple damaged7. Control valve damaged	<ol style="list-style-type: none">1. Press in control knob fully2. After pilot lights, keep control knob pressed in 30 seconds3. Fully open manual shut-off valve4. A) Contact local gas company B) Clean pilot or replace pilot assembly5. Hand tighten until snug, then tighten 1/4 turn more6. Replace thermocouple7. Replace control valve

VANGUARD® VDVVF36P and VDVVF36ST Series DIRECT-VENT GAS FIREPLACE HEATER

TROUBLESHOOTING

Continued

OBSERVED PROBLEM	POSSIBLE CAUSE	REMEDY
Burner does not light after pilot is lit	<ol style="list-style-type: none">1. Burner orifice clogged2. Inlet gas pressure is too low3. Thermopile leads disconnected or improperly connected4. Thermopile is defective	<ol style="list-style-type: none">1. Clean burner or replace burner orifice2. Contact local propane/LP or natural gas company3. Reconnect leads4. Replace thermopile
Delayed ignition burner	<ol style="list-style-type: none">1. Manifold pressure is too low2. Burner porting or orifice clogged	<ol style="list-style-type: none">1. Contact local propane/LP or natural gas company2. Clean burner or replace burner orifice
Burner backfiring during combustion	<ol style="list-style-type: none">1. Burner orifice is clogged or damaged2. Damaged burner3. Gas regulator defective	<ol style="list-style-type: none">1. Clean burner or replace burner orifice2. Replace damaged burner3. Replace gas control
Slight smoke or odor during initial operation	<ol style="list-style-type: none">1. Residues from manufacturing processes and logs curing	<ol style="list-style-type: none">1. Problem will stop after a few hours of operation
Heater produces a whistling noise when burner is lit	<ol style="list-style-type: none">1. Turning control knob to HI position when burner is cold2. Air in gas line3. Dirty or partially clogged burner orifice	<ol style="list-style-type: none">1. Turn control knob to LO position and let warm up for a minute2. Operate burner until air is removed from line. Have gas line checked by local propane/LP gas company3. Clean burner or replace burner orifice
Glass soots	<ol style="list-style-type: none">1. Flame impingement on logs2. Debris around burner air mixer	<ol style="list-style-type: none">1. Adjust the log set so that the flame does not excessively impinge on it2. Inspect the opening at the base of the burner to see that it is NOT packed with any type of material
Fireplace produces a clicking/ticking noise just after burners are lit or shut off	<ol style="list-style-type: none">1. Metal expanding while heating or contracting while cooling	<ol style="list-style-type: none">1. This is common. If noise is excessive, contact qualified service person

OWNER'S MANUAL

TROUBLESHOOTING

Continued

- ⚠ WARNING: If you smell gas**
- Shut off gas supply.
 - Do not try to light any appliance.
 - Do not touch any electrical switch; do not use any phone in your building.
 - Immediately call your gas supplier from a neighbor's phone. Follow the gas supplier's instructions.
 - If you cannot reach your gas supplier, call the fire department.

IMPORTANT: Operating fireplace where impurities in air exist may create odors. Cleaning supplies, paint, paint remover, cigarette smoke, cements and glues, new carpet or textiles, etc., create fumes. These fumes may mix with combustion air and create odors.

OBSERVED PROBLEM	POSSIBLE CAUSE	REMEDY
Fireplace produces unwanted odors	1. Gas leak. See Warning statement above	1. Locate and correct all leaks
Fireplace shuts off in use	1. High or gusting winds 2. Low line pressure 3. Pilot is partially clogged 4. Inner vent pipe leaking exhaust gasses into system 5. Horizontal vent improperly pitched 6. Glass too loose and air tight gasket leaks in corners after usage 7. Bad thermopile or thermocouple 8. Improper vent cap installation	1. Fireplace has been tested for up to 40mph winds. However, extreme conditions may occur 2. Contact local propane/LP or natural gas company 3. Clean pilot 4. Locate and correct all leaks 5. Horizontal vent termination should slope down only enough to prevent any water from entering the unit. The maximum downward slope of the vent termination is 1/4" for any horizontal run 6. Tighten glass 7. Replace faulty component 8. Check for proper installation and freedom from debris or blockage
Gas odor even when control knob is in OFF position	1. Gas leak. See Warning statement above 2. Control valve defective	1. Locate and correct all leaks 2. Replace control valve
Gas odor during combustion	1. Gas leak. See Warning statement above	1. Locate and correct all leaks
Dark residue on logs or inside of fireplace	1. Improper log placement 2. Air holes at burner inlet blocked 3. Burner flame holes blocked	1. Properly locate logs 2. Clean out air holes at burner inlets. Periodically repeat as needed 3. Remove blockage or replace burner

VANGUARD® VDV36P and VDV36ST Series DIRECT-VENT GAS FIREPLACE HEATER

ACCESSORIES

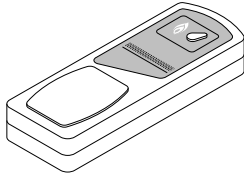

RECEIVER AND HAND-HELD ON/OFF REMOTE CONTROL KIT - GHRC

For all models. Allows the gas log heater to be turned on and off by using a hand-held remote control.

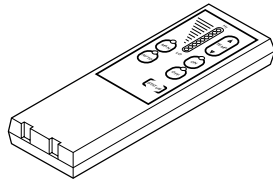

RECEIVER AND HAND-HELD THERMOSTAT REMOTE CONTROL KIT - GHRCT

For all models. Allows the gas log heater to be operated in a manually or thermostatically controlled mode. You can turn the gas log heater on and off without ever leaving the comfort of your easy chair.



BLOWER KIT - DAVDBK (02261)

For all models. Increases air circulation to maximize heat distribution.

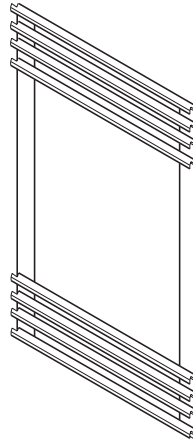

END LOUVER KIT (Peninsula Only) Brass - VELP20 (01638)

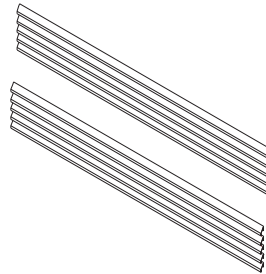

LOUVER KIT Brass - VFLP36 (01628)

REPLACEMENT PARTS

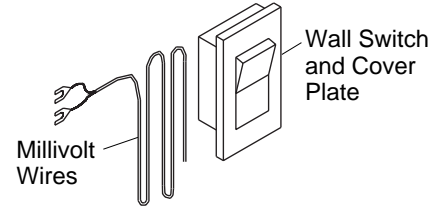

WALL SWITCH KIT 105742-01 (22180)

Wall Switch - 105902-01 (14112)
Cover Plate - 105903-01 (14113)

Wall switch, cover plate, and millivolt wires are supplied with the appliance. If wires need replacing, use proper gauge.

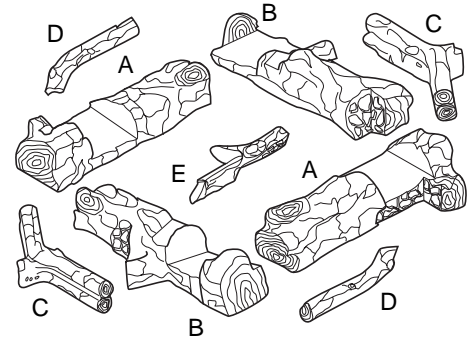

LOG SET - 105891-01 (27237)

Log Piece A - 105896-01 (27238)
Log Piece B - 105895-01 (27239)
Log Piece C - 105893-01 (27242)
Log Piece D - 105892-01 (27240)
Log Piece E - 105894-01 (27241)

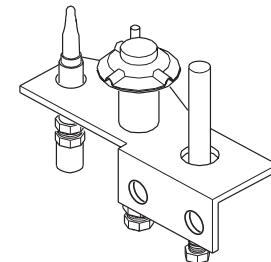

PILOT ASSEMBLY

Natural - 105883-01 (25701)
Propane/LP - 105883-02 (25702)

If in need of replacing, have a qualified technician replace it.

REPLACEMENT PARTS

Continued



Front (Bottom)



Left/Right (Bottom)



Rear (Used for Peninsula and See Thru)

REFRACTORY PIECES

Front (Bottom)

105886-01 (25854)

Left/Right (Bottom)

105887-01 (25856)

Rear - 105888-01 (25855)

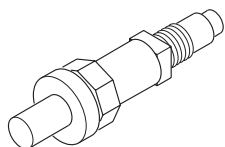

PIEZO IGNITOR - 105884-01 (14261)

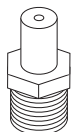

ORIFICE

Natural - 105890-01 (27224)

Propane/LP - 105890-02 (25238)

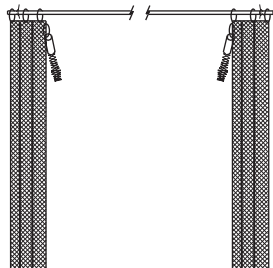

SCREEN ASSEMBLY
105898-01 (25903)

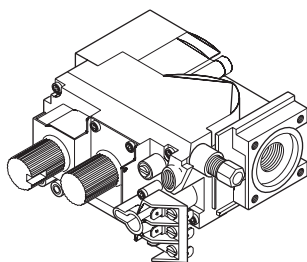

GAS CONTROL VALVE

Natural - 105882-01 (25699)

Propane/LP - 105882-02 (25700)

If in need of replacing, have a qualified technician replace it.

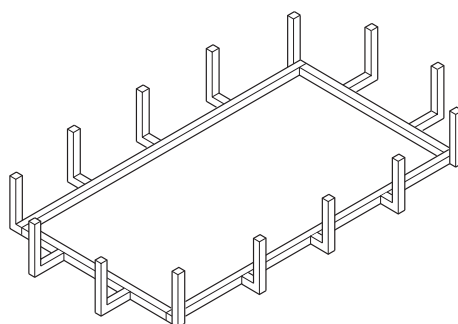

GRATE - 105889-01 (11184)

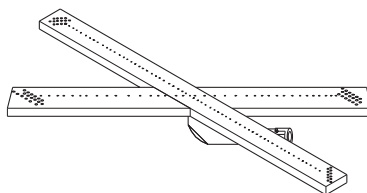

BURNER ASSEMBLY
105885-01 (27243)

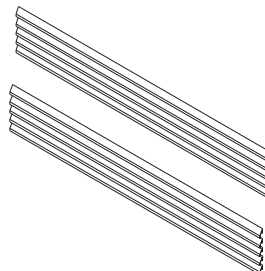

LOUVER KIT
Black - 105904-01 (01627)

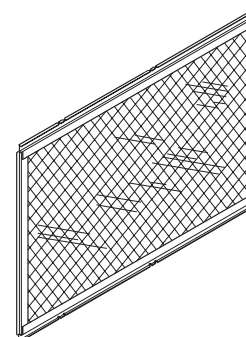

DOOR ASSEMBLY (Ceramic)
105897-01 (25706)

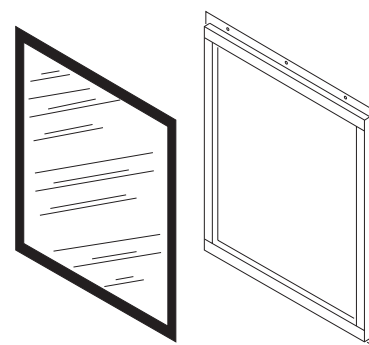

END GLASS ASSEMBLY
(Peninsula Only)
105899-01 (25709) (Ceramic)

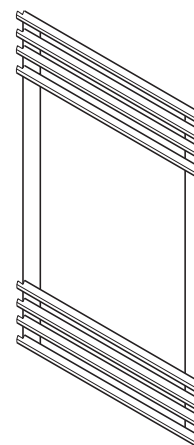

END LOUVER KIT
(Peninsula Only)
Standard - 105900-01 (01645)

WARRANTY INFORMATION

KEEP THIS WARRANTY

Model _____

Serial No. _____

Date Purchased _____

Always specify model and serial numbers when communicating with the factory.

We reserve the right to amend these specifications at any time without notice. The only warranty applicable is our standard written warranty. We make no other warranty, expressed or implied.

LIMITED WARRANTY DIRECT-VENT FIREPLACE

DESA International warrants this product to be free from defects in materials and components for four (4) years from the date of first purchase, provided that the product has been properly installed, operated and maintained in accordance with all applicable instructions. To make a claim under this warranty the Bill of Sale or cancelled check must be presented.

This warranty is extended only to the original retail purchaser. This warranty covers the cost of part(s) required to restore this heater to proper operating condition and an allowance for labor when provided by a DESA Authorized Service Center. Warranty part(s) MUST be obtained through authorized dealers of this product and/or DESA International who will provide original factory replacement parts. Failure to use original factory replacement parts voids this warranty. The heater MUST be installed by a qualified installer in accordance with all local codes and instructions furnished with the unit.

This warranty does not apply to parts that are not in original condition because of normal wear and tear, or parts that fail or become damaged as a result of misuse, accidents, lack of proper maintenance or defects caused by improper installation. Travel, diagnostic cost, labor, transportation and any and all such other costs related to repairing a defective heater will be the responsibility of the owner.

TO THE FULL EXTENT ALLOWED BY THE LAW OF THE JURISDICTION THAT GOVERNS THE SALE OF THE PRODUCT; THIS EXPRESS WARRANTY EXCLUDES ANY AND ALL OTHER EXPRESSED WARRANTIES AND LIMITS THE DURATION OF ANY AND ALL IMPLIED WARRANTIES, INCLUDING WARRANTIES OF MERCHANTABILITY AND FITNESS FOR A PARTICULAR PURPOSE TO FOUR (4) YEARS ON ALL COMPONENTS FROM THE DATE OF FIRST PURCHASE; AND DESA INTERNATIONAL'S LIABILITY IS HEREBY LIMITED TO THE PURCHASE PRICE OF THE PRODUCT AND DESA INTERNATIONAL SHALL NOT BE LIABLE FOR ANY OTHER DAMAGES WHATSOEVER INCLUDING INDIRECT, INCIDENTAL OR CONSEQUENTIAL DAMAGES.

Some states do not allow a limitation on how long an implied warranty lasts or an exclusion or limitation of incidental or consequential damages, so the above limitation on implied warranties, or exclusion or limitation on damages may not apply to you.

This warranty gives you specific legal rights, and you may also have other rights that vary from state to state.

For information about this warranty write:

DESA
INTERNATIONAL

2701 Industrial Drive
P.O. Box 90004
Bowling Green, KY 42102-9004
www.desatech.com



105706 01

NOT A UPC

105706-01
55741
Rev. A
06/99