

**INSTALLER/CONSUMER  
SAFETY INFORMATION**

**PLEASE READ THIS MANUAL  
BEFORE INSTALLING AND  
USING APPLIANCE**

**WARNING!**

**IF THE INFORMATION IN THIS  
MANUAL IS NOT FOLLOWED  
EXACTLY, A FIRE OR  
EXPLOSION MAY RESULT  
CAUSING PROPERTY DAMAGE,  
PERSONAL INJURY OR LOSS  
OF LIFE.**

**FOR YOUR SAFETY**

**Installation and service must  
be performed by a qualified  
installer, service agency or the  
gas supplier.**

**WHAT TO DO IF YOU SMELL GAS:**

- Do not try to light any appliance.
- Do not touch any electric switch; do not use any phone in your building.
- Immediately call your gas supplier from your neighbor's phone. Follow the gas suppliers instructions.
- If you cannot reach your gas supplier call the fire department.

**DO NOT STORE OR USE  
GASOLINE OR OTHER  
FLAMMABLE VAPORS AND  
LIQUIDS IN THE VICINITY OF  
THIS OR ANY OTHER  
APPLIANCE.**

**WARNING: Improper installation,  
adjustment, alteration, service or  
maintenance can cause injury or  
property damage. Refer to this  
manual. For assistance or additional  
information, consult a qualified  
installer, service agency or the gas  
supplier.**

# TEMCO

## FIREPLACE PRODUCTS

### **Builder Rear Vent Direct Vent Zero Clearance Gas Fireplace Heater Models: 33RDVDSN, 36RDVDSN, 39RDVDSN**

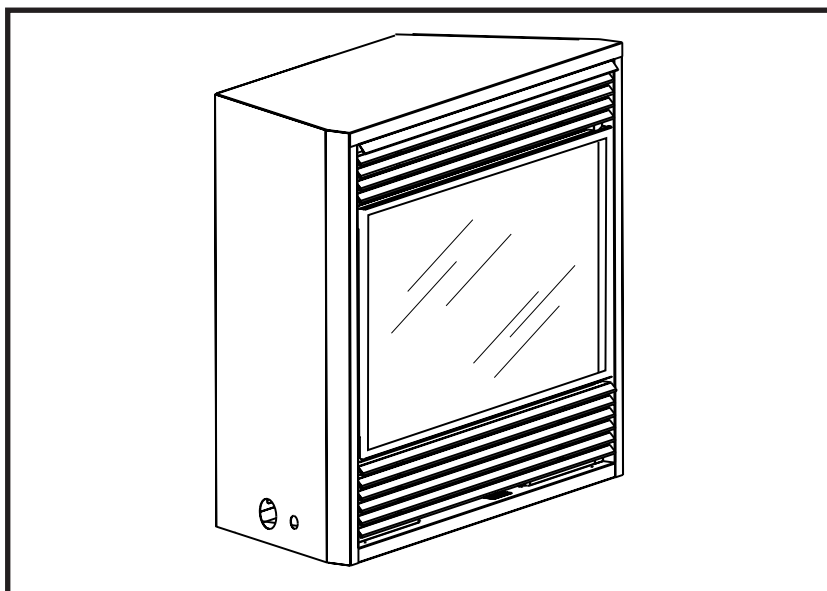

### **Installation Instructions and Homeowner's Manual**



**INSTALLER: Leave this manual with the appliance.  
CONSUMER: Retain this manual for future reference.**

# Table of Contents

**PLEASE READ THE INSTALLATION & OPERATING INSTRUCTIONS BEFORE USING THIS APPLIANCE.**

Thank you and congratulations on your purchase of a CFM Corporation fireplace.

**IMPORTANT: Read all instructions and warnings carefully before starting installation.**

**Failure to follow these instructions may result in a possible fire hazard and will void the warranty.**

## Installation & Operating Instructions

General Information, Warnings, Cautions.....	3
Requirements for the Commonwealth of Massachusetts .....	4
Fireplace Dimensions .....	5
Locating Your Fireplace .....	6
Clearance to Combustibles .....	6
Mantels .....	6
Hearth .....	7
Framing & Finishing.....	7
Final Finishing .....	7
Gas Specifications.....	7
Gas Inlet and Manifold Pressures .....	7
High Elevations.....	7
Gas Line Installation .....	8
EB-1 Electrical Box.....	8

## General Venting Information

General Venting.....	9
General Venting Information-Termination Location .....	10
General Information on Assembling Vent Pipes .....	11
Flex Vent Pipes.....	11
Twist Lock Pipes.....	12
How to Use the Vent Graph.....	12
Rear Wall Vent Application & Installation.....	12
Vertical Sidewall Applications & Installation.....	14
Below Grade Installations.....	18
Vertical Through-the-Roof Applications & Installation.....	19
Venting Components .....	21

## Operating Instructions

Glass Information .....	22
Louvre Removal .....	22
Window Frame Assembly Removal.....	22
Glass Cleaning .....	22
Installation of Logs, Lava Rock & Ember Material .....	23
Lighting & Operating Instructions .....	25
Troubleshooting.....	26
Fuel Conversion Instructions .....	27

## Maintenance

Unit Adjustment .....	29
Maintenance .....	30

## Replacement Parts

.....	32
-------	----

## Optional Accessories

Fan Kits .....	34
Wiring Instructions .....	35
Ceramic Refractory Kits.....	35
Decorative Bay Windows.....	35
Bay Window Screen .....	36
Remote Controls.....	36

<b>Warranty</b> .....	40
-----------------------	----

<b>Installation and Startup Checklist</b> .....	41
---	----

<b>Warranty Registration</b> .....	43
------------------------------------	----

<b>Energide</b> .....	44
-----------------------	----

## Installation & Operating Instructions

This gas fireplace should be installed by a qualified installer, preferably NFI or WETT (Canada) certified, in accordance with local building codes and with current CSA-B149.1 Installation codes for Gas Burning Appliances and Equipment. For USA Installations follow local codes and/or the current National Fuel Gas Code. ANSI Z223.1/NFPA 54.

FOR SAFE INSTALLATION AND OPERATION PLEASE NOTE THE FOLLOWING:

1. This fireplace gives off high temperatures and should be located out of high traffic areas and away from furniture and draperies.
2. Children and adults should be alerted to the hazards of the high surface temperatures of this fireplace and should stay away to avoid burns or ignition of clothing.
3. **CAUTION: Due to high glass surface temperature children should be carefully supervised when in the same room as fireplace.**



4. Under no circumstances should this fireplace be modified. Parts removed for servicing should be replaced prior to operating this fireplace again.
5. Installation and any repairs to this fireplace must be performed by a qualified installer, service agency or gas supplier. A professional service person should be contacted to inspect the fireplace annually. More frequent cleaning may be required due to excess lint and dust from carpeting, bedding material, etc.
6. Control compartments, burners and air passages in this fireplace should be kept clean and free of dust and lint. Make sure that the gas valve and pilot light are turned off before you attempt to clean this fireplace.
7. The venting system (chimney) of this fireplace should be checked at least once a year and if needed your venting system should be cleaned.
8. Keep the area around your fireplace clear of combustible materials, gasoline and other flammable vapour and liquids. This fireplace should not be used as a dry-ing rack for clothing, nor should Christmas stockings or decorations be hung on or around the fireplace.
9. Under no circumstances should any solid fuels (wood, coal, paper or cardboard etc.) be used in this fireplace.
10. The flow of combustion and ventilation air must not be obstructed in any way.
11. When the fireplace is installed directly on carpeting, vinyl tile or any combustible material other than wood, this fireplace must be installed on a metal or wood panel extending the full width and depth of the fireplace.

12. This fireplace requires adequate ventilation and combustion air to operate properly.
13. This fireplace must not be connected to a chimney flue serving a separate solid fuel burning fireplace.
14. When the fireplace is not in use it is recommended that the gas control valve be left in the **OFF** position.
15. These units have been approved for bedroom use.

**33RDVDSN / 33RDVDSP / 36RDVDSN /  
36RDVDSP / 39RDVDSN / 39RDVDSP**  
**Certified To**

**ANSI Z21.88-2005 / CSA 2.33-2005 / UL307B**  
**Vented Gas Fireplace Heaters**

**WARNING: Check with your electronics manufacturer before installing a television or other electronic device above this fireplace.**

**This appliance may be installed in an aftermarket permanently located, manufactured home or mobile home, where not prohibited by local codes. This appliance is only for use with the type of gas indicated on the rating plate. This appliance is not convertible for use with other gases, unless a certified kit is used.**

### IMPORTANT:

#### PLEASE REVIEW THE FOLLOWING CAREFULLY

Remove any plastic from from parts before turning the fireplace ON.  
It is normal for fireplaces fabricated of steel to give off some expansion and/or contraction noises during the start up or cool down cycle. Similar noises are found with your furnace heat exchanger or car engine.  
It is not unusual for your gas fireplace to give off some odor the first time it is burned. This is due to the curing of the paint and any undetected oil from the manufacturing process.  
**Please ensure that your room is well ventilated-open all windows.**  
It is recommended that you burn your fireplace for at least ten four (4) hours the first time you use it. If the optional fan kit has been installed, place the fan switch in the "OFF" position during this time.

**Proposition 65 Warning:** Fuels used in gas, wood-burning or oil fired appliances, and the products of combustion of such fuels, contain chemicals known to the State of California to cause cancer, birth defects and other reproductive harm.  
California Health & Safety Code Sec. 25249.6

# Installation & Operating Instructions

## Requirements for the Commonwealth of Massachusetts

All gas fitting and installation of this heater shall only be done by a licensed gas fitter or licensed plumber.

For all side wall horizontally vented gas fueled equipment installed in every dwelling, building or structure used in whole or in part for residential purposes, including those owned or operated by the Commonwealth and where the side wall exhaust vent termination is less than seven (7) feet above finished grade in the area of the venting, including but not limited to decks and porches, the following requirements shall be satisfied:

### Installation of Carbon Monoxide Detectors

At the time of installation of the side wall horizontal vented gas fueled equipment, the installing plumber or gas fitter shall observe that a hard wired carbon monoxide detector with an alarm is installed on each additional level of the dwelling, building or structure served by the side wall horizontally vented gas fueled equipment. It shall be the responsibility of the property owner to secure the services of qualified licensed professionals for the installation of hard wired carbon monoxide detectors.

In the event that the side wall horizontally vented gas fueled equipment is installed in a crawl space or an attic, the hard wired carbon monoxide detector with alarm and battery back-up may be installed on the next adjacent floor level.

In the event that the requirements of this subdivision can not be met at the time of completion of installation, the owner shall have a period of thirty (30) days to comply with the above requirements; provided, however, that during said thirty (30) day period, a battery operated carbon monoxide detector with an alarm shall be installed.

### Approved Carbon Monoxide Detectors

Each carbon monoxide detector as required in accordance with the above provisions shall comply with NFPA 720 and ANSI/UL 2034 listed and IAS certified.

### Signage

A metal or plastic identification plate shall be permanently mounted to the exterior of the building at a minimum height of eight (8) feet above grade directly in line with the exhaust vent terminal for the horizontally vented gas fueled heating appliance or equipment. The sign shall read, in print size no less than one-half (1/2) inch in size, "**GAS VENT DIRECTLY BELOW, KEEP CLEAR OF ALL OBSTRUCTIONS**".

## Inspection

The state or local gas inspector of the side wall horizontally vented gas fueled equipment shall not approve the installation unless, upon inspection, the inspector observes carbon monoxide detectors and signage installed in accordance with the provisions of 248 CMR 5.08(2)(a)1 through 4.

## Exemptions

The following equipment is exempt from 248 CMR 5.08(2)(a)1 through 4:

- The equipment listed in Chapter 10 entitled "Equipment Not Required To Be Vented" in the most current edition of NFPA 54 as adopted by the Board; and
- Product Approved side wall horizontally vented gas fueled equipment installed in a room or structure separate from the dwelling, building or structure used in whole or in part for residential purposes.

## MANUFACTURER REQUIREMENTS

### Gas Equipment Venting System Provided

When the manufacturer of Product Approved side wall horizontally vented gas equipment provides a venting system design or venting system components with the equipment, the instructions provided by the manufacturer for installation of the equipment and the venting system shall include:

- Detailed instructions for the installation of the venting system design or the venting system components; and
- A complete parts list for the venting system design or venting system.

### Gas Equipment Venting System NOT Provided

When the manufacturer of a Product Approved side wall horizontally vented gas fueled equipment does not provide the parts for venting the flue gases, but identifies "special venting systems", the following requirements shall be satisfied by the manufacturer:

- The referenced "special venting system" instructions shall be included with the appliance or equipment installation instructions; and
- The "special venting systems" shall be Product Approved by the Board, and the instructions for that system shall include a parts list and detailed installation instructions.

A copy of all installation instructions for all Product Approved side wall horizontally vented gas fueled equipment, all venting instructions, all parts lists for venting instructions, and/or all venting design instructions shall remain with the appliance or equipment at the completion of the installation.

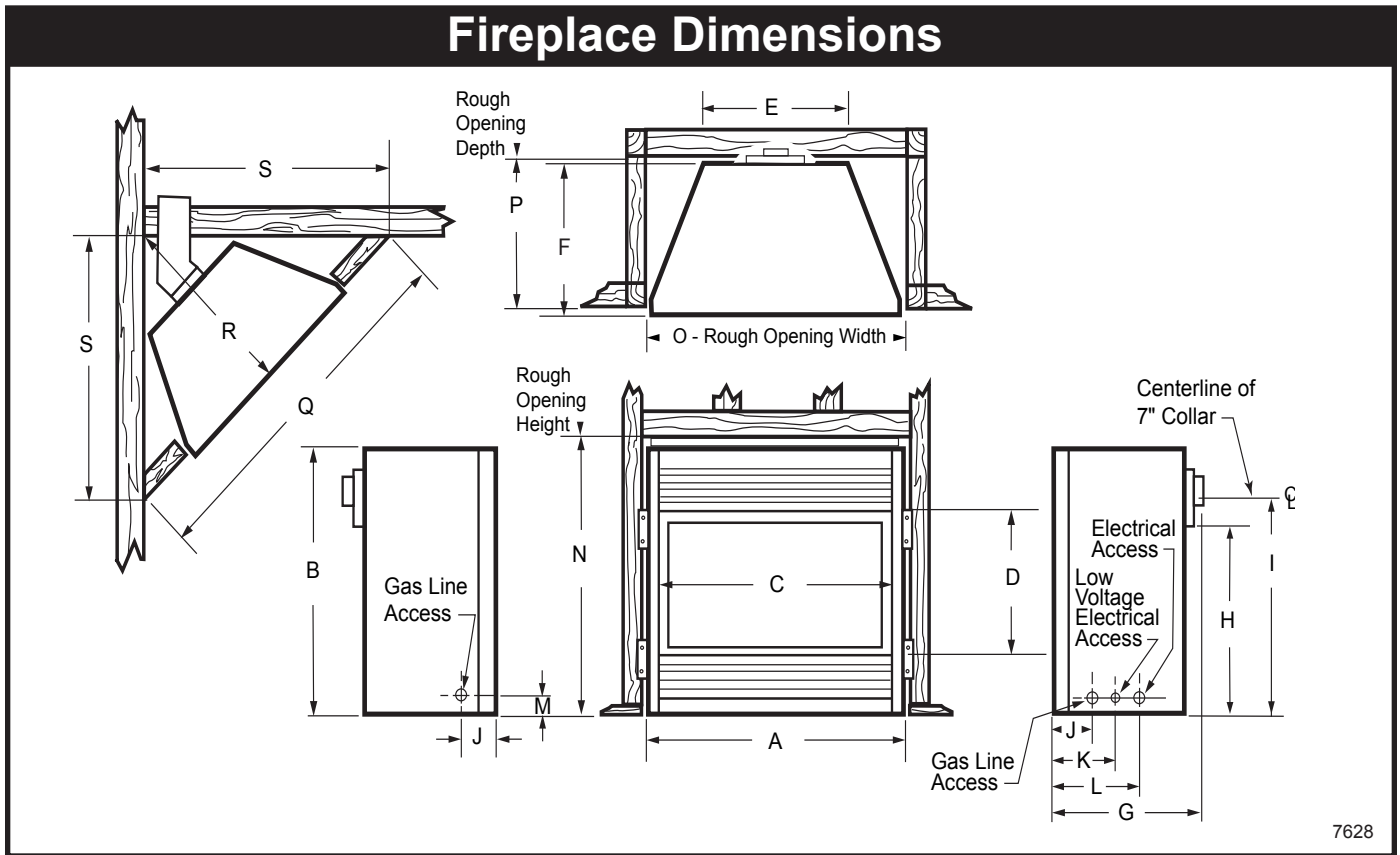

Fig. 1 Fireplace specifications and framing dimensions.

Ref.	33RDVDSN	36RDVDSN	39RDVDSN
A	33" (838 mm)	36" (914 mm)	39" (991 mm)
B	28 <sup>7</sup> / <sub>8</sub> " (733 mm)	34 <sup>1</sup> / <sub>4</sub> " (870 mm)	34 <sup>1</sup> / <sub>4</sub> " (870 mm)
C	31" (787 mm)	33" (838 mm)	36" (914 mm)
D	16 <sup>3</sup> / <sub>8</sub> " (416 mm)	21" (533 mm)	21" (533 mm)
E	22" (559 mm)	24" (610 mm)	24" (610 mm)
F	11 <sup>1</sup> / <sub>2</sub> " (292 mm)	16" (406 mm)	16" (406 mm)
G	14 <sup>3</sup> / <sub>4</sub> " (375 mm)	19" (483 mm)	19" (483 mm)
H	20 <sup>1</sup> / <sub>4</sub> " (515 mm)	23 <sup>7</sup> / <sub>8</sub> " (606 mm)	23 <sup>7</sup> / <sub>8</sub> " (606 mm)
I	23 <sup>3</sup> / <sub>4</sub> " (603 mm)	27 <sup>1</sup> / <sub>2</sub> " (699 mm)	27 <sup>3</sup> / <sub>8</sub> " (695 mm)
J	5" (127 mm)	6 <sup>3</sup> / <sub>4</sub> " (171 mm)	6 <sup>1</sup> / <sub>4</sub> " (159 mm)
K	7 <sup>1</sup> / <sub>2</sub> " (191 mm)	10" (254 mm)	8 <sup>3</sup> / <sub>8</sub> " (213 mm)
L	8 <sup>1</sup> / <sub>2</sub> " (216 mm)	13 <sup>1</sup> / <sub>2</sub> " (343 mm)	12 <sup>1</sup> / <sub>2</sub> " (318 mm)
M	1 <sup>7</sup> / <sub>8</sub> " (18 mm)	1 <sup>7</sup> / <sub>8</sub> " (18 mm)	1 <sup>7</sup> / <sub>8</sub> " (18 mm)
Framing Dimensions			
N	29" (737 mm)	35" (889 mm)	35" (889 mm)
O	33 <sup>1</sup> / <sub>2</sub> " (851 mm)	36 <sup>1</sup> / <sub>2</sub> " (927 mm)	39 <sup>1</sup> / <sub>2</sub> " (1003 mm)
P	12" (305 mm)	16 <sup>1</sup> / <sub>2</sub> " (419 mm)	16 <sup>1</sup> / <sub>2</sub> " (419 mm)
Q	51" (1295 mm)	58 <sup>7</sup> / <sub>8</sub> " (1495 mm)	62 <sup>1</sup> / <sub>4</sub> " (1581 mm)
R	25 <sup>1</sup> / <sub>2</sub> " (648 mm)	29 <sup>7</sup> / <sub>8</sub> " (748 mm)	31 <sup>1</sup> / <sub>8</sub> " (790 mm)
S	36" (914 mm)	41 <sup>5</sup> / <sub>8</sub> " (1057 mm)	44" (1118 mm)

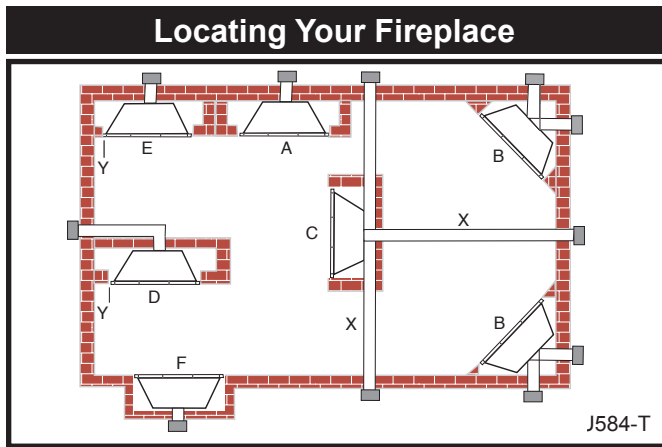

Fig. 2 Locate gas fireplace.

A - Flat on wall    B - Cross corner    C - \*\*Island  
 D - Room divider    E - Flat on wall corner    F - Chase installation  
 Y - Refer to "Clearance to Combustibles" Section

**Note (Fig. 2):**

\*\* Island (C) and Room Divider (D) installation is possible as long as the horizontal portion of the vent system (X) does not exceed 20' (6 m). See details in manual Venting Section.

**Clearance to Combustibles**

Top of Unit to Ceiling ..... 36" (914 mm)  
 Front of Unit to Combustibles ..... 36" (914 mm)

**Appliance**

Top ..... 0" (0 mm)  
 Bottom ..... 0" (0 mm)  
 Side ..... 0" (0 mm)  
 Back ..... 0" (0 mm)

**Venting**

Concentric sections of DV Vent

Top, bottom & sides ..... 1" (25 mm)

Rear Vent Applications

Top ..... 2" (51 mm)  
 Sides and Bottom ..... 1" (25 mm)  
 Flex Vent ..... 7/8" (22 mm)

**Mantels**

The height that a combustible mantel is fitted above the fireplace is dependent on the depth of the mantel. This also applies to the distance between the mantel leg (if fitted) and the fireplace.

For the correct mounting height and widths refer to Figures 3a and 3b.

The fitting of a bay window trim kit does not effect the distances and reference points referred to in the diagram and chart.

Noncombustible mantels and legs may be installed at any height and width around the appliance.

When using paint or lacquer to finish the mantel, such paint or lacquer must be heat resistant to prevent discoloration.

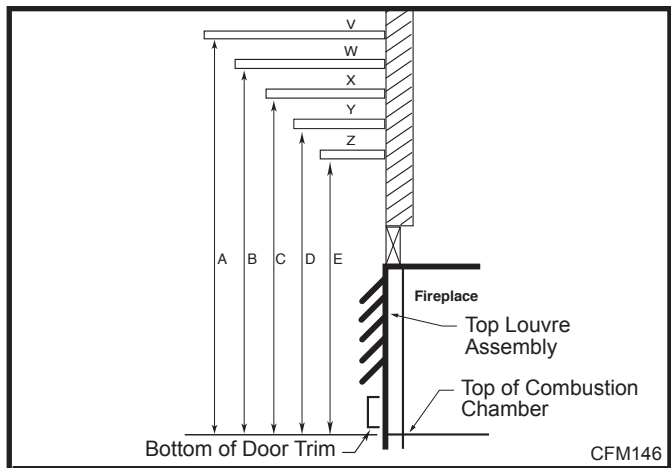

**Mantel Chart**

Ref.	Mantel Shelf or Breast Plate Depth	Ref.	Mantel from Top of Combustion Chamber	
			36/39/RDVDSN	33RDVDSN
V	10" (254 mm)	A	19" (483 mm)	17" (432 mm)
W	8" (203 mm)	B	17" (432 mm)	15" (381 mm)
X	6" (152 mm)	C	15" (381 mm)	13" (330 mm)
Y	4" (101 mm)	D	13" (330 mm)	11" (279 mm)
Z	2" (51 mm)	E	11" (279 mm)	9" (229 mm)

Fig. 3a Combustible mantel minimum installation.

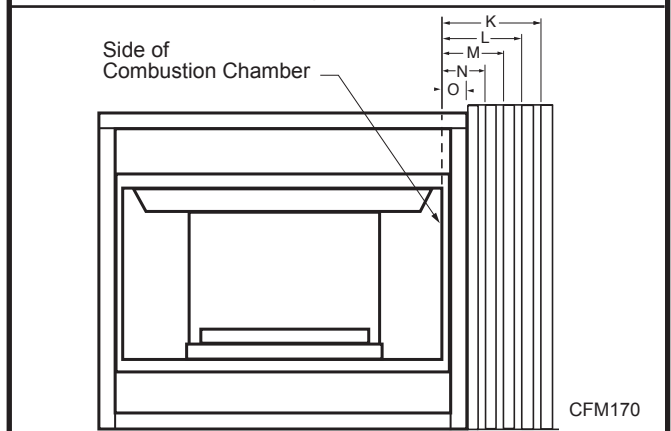
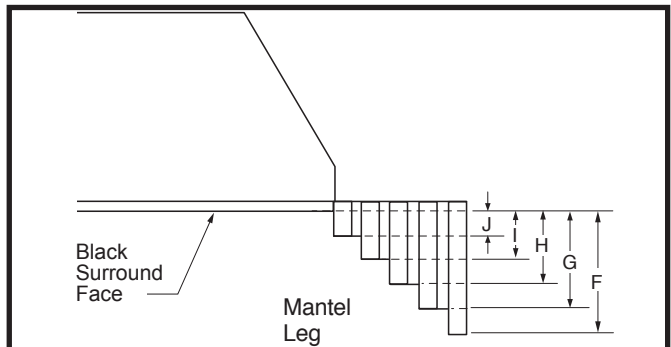

Ref.	Mantel Leg Depth	Ref.	Mantel Leg from Side of Comb. Opening
F	10" (254 mm)	K	11½" (292 mm)
G	8" (203 mm)	L	9½" (241 mm)
H	6" (152 mm)	M	7½" (191 mm)
I	4" (101 mm)	N	5½" (140 mm)
J	2" (51 mm)	O	3½" (89 mm)

Fig. 3b Combustible mantel leg minimum installation.

## Hearth

A hearth is not mandatory but is recommended for aesthetic purposes. We recommend a noncombustible hearth which projects out 12" (305mm) or more from the front of the fireplace.

### Cold climate installation recommendation:



**When installing this unit against a non-insulated exterior wall or chase, it is mandatory that the outer walls be insulated to conform to applicable insulation codes.**

**NOTE: Never allow vapor barrier to contact the outer casing of this fireplace or venting.**

## Framing and Finishing

1. Choose the unit location.
2. Place the unit into position and secure it to the floor with 1/2" (38mm) screws, or nails. The holes to secure the unit to the floor are located just behind the access door grille on the left and right side of the unit.
3. Frame in the fireplace with a header across the top. It is important to allow for the finished wall face when setting the depth of the frame.
4. Attach the fireplace to the frame using the adjustable frame drywall strips (located behind the access door for shipping). Preset the depth to suit the facing material of the wall. The strips are adjustable to 1/2" (13 mm), 5/8" (16 mm) or 3/4" (19 mm). (Fig. 4)
5. Screw through the slotted holes in the drywall strip and into the pre-drilled holes in the fireplace side. Measure from the face of the fireplace to the face of the drywall strip to confirm the final depth.

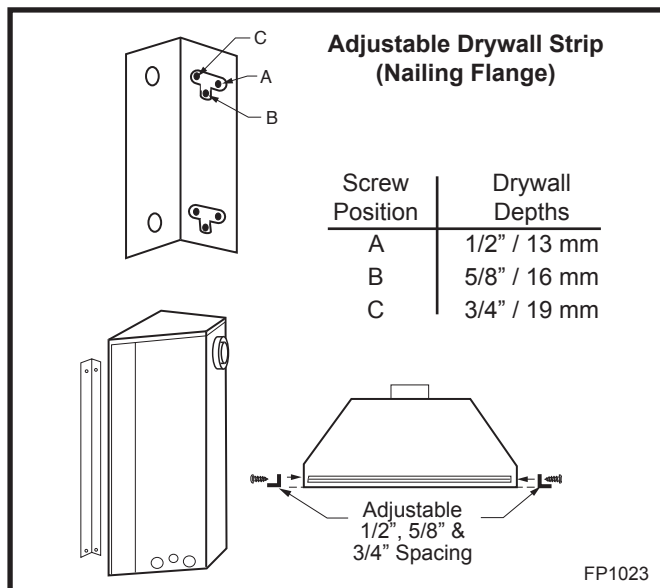

Fig. 4 Nailing flanges.

20007894

## Final Finishing

Noncombustible materials such as brick or tile may be extended over the edges of the face of the appliance. **DO NOT** cover any vent or grille panels.

If a Trim Kit is going to be installed on the fireplace, the brick or tile will have to be installed flush with the edges of the appliance.

## Gas Specifications

Model	Fuel	Gas Control	Max. Input BTU/h	Min. Input BTU/h
33RDVN	Nat	Millivolt	18,000	13,000
33RDVP	Prop	Millivolt	18,000	13,000
33RDVDSN	Nat	120 V	18,000	n/a
33RDVDSP	Prop	120 V	18,000	n/a
36RDVN	Nat	Millivolt	20,000	13,000
36RDVP	Prop	Millivolt	20,000	13,000
36RDVDSN	Nat	120 V	20,000	n/a
36RDVDSP	Prop	120 V	20,000	n/a
39RDVN	Nat	Millivolt	22,000	15,000
39RDVP	Prop	Millivolt	22,000	15,000
39RDVDSN	Nat	120 V	22,000	n/a
39RDVDSP	Prop	120 V	22,000	n/a

## Gas Inlet and Manifold Pressures

	Natural	LP (Propane)
Inlet Minimum	4.5" w.c.	10.8" w.c.
Inlet Maximum	14.0" w.c.	14.0" w.c.
Manifold Pressure	3.5" w.c.	10.0" w.c.

## High Elevations

Input ratings are shown in BTU per hour and are certified without deration for elevations up to 4,500 feet (1,370m) above sea level.

For elevations above 4,500 feet (1,370m) in USA, installations must be in accordance with the current ANSI Z223.1/NFPA 54 and/or local codes having jurisdiction.

In Canada, please consult provincial and/or local authorities having jurisdiction for installations at elevations above 4,500 feet (1,370m).

## Gas Line Installation



**When purging gas line, the front window frame assembly must be removed.**

1. The gas pipeline can be brought in through the rear of the fireplace as well as the bottom. Knockouts are provided on the bottom behind the valve to allow for the gas pipe installation and testing of any gas connection. It is most convenient to bring the gas line in from the rear right side of the valve as this allows fan installation or removal without disconnecting the gas line.

The gas line connection can be made with properly tinned 3/8" copper tubing, 3/8" rigid pipe or an approved flex connector. Since some municipalities have additional local codes, it is always best to consult your local authority and the National Fuel Gas Code, ANSI Z223.1/NFPA 54 in the USA or the CSA-B149.1 installation codes.

\*Adhere to the following installation requirements in the State of Massachusetts:

- The installer must be a licensed plumber or gas fitter.
- Flex connectors must be Massachusetts approved, cannot exceed 36" (914 mm) in length, must be a minimum 1/2" dia. and may not penetrate a wall.

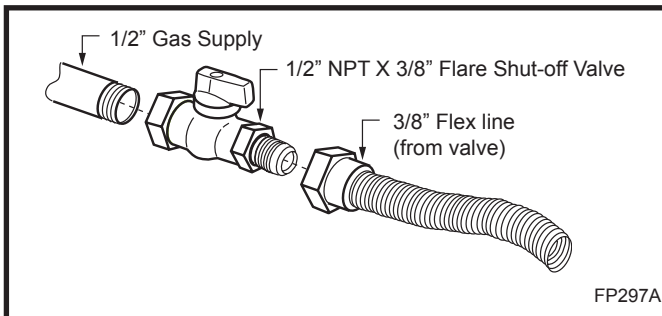

Fig. 5 Typical gas supply installation.

2. The gas control inlet is 3/8" NPT. typical installation layout for rigid pipe is shown in Figure 8.

**NOTE: All models are equipped with a flex tube with a shut off valve having a 1/2" NPT inlet. The flex line with shut off is shipped in the control valve compartment. Using two wrenches, tighten the flexible tube at the shut off valve and at the gas control**

3. When using a flex connector,\* use only approved fittings. When a union is installed, provide easy access in its placement for servicing. Refer to gas specification for pressure details and ratings.
4. When a vertical section of gas pipe is required for the installation, a condensation trap is needed. In Canada see CSA-B149.1 for code details. See the National Fuel Gas Code ANSI Z223.1/NFPA 54 in the USA.

5. For natural gas, a minimum of 3/8" iron pipe with a gas supply pressure of 4.5" w.c. (from the gas meter). Consult with local gas utility and ANSI Z223.1/NFPA 54 if any questions arise concerning pipe sizes.
6. Turn the gas supply to 'ON' and check for leaks. **DO NOT USE OPEN FLAME FOR THIS PURPOSE.** Use an approved leak testing solution.
7. The appliance and its appliance main gas valve must be disconnected from the gas supply piping system during any pressure testing of that system at test pressures in excess of 1/2 psig (3.5K Pa).
8. This appliance must be isolated from the gas supply piping system by closing its equipment shut off valve during any pressure testing of the gas supply piping system at test pressures equal to 1/2 psig (3.5K Pa).



**Always check for gas leaks with a mild soap and water solution. Do not use an open flame for leak testing.**

When using copper or flex connector use only approved fittings. Always provide a union when using black iron pipe so that the gas line can be easily disconnected for burner or fan servicing. See gas specifications for pressure details and ratings.

The fireplace valve must not be subjected to any test pressures exceeding 1/2 psi. Isolate or disconnect this or any other gas appliance control from the gas line when pressure testing.

## EB-1 Electrical Box



**The fireplace, when installed, must be electrically connected and grounded in accordance with local codes or, in the absence of local codes, with the current CSA C22.1 Canadian Electrical Code.**



**For USA installations follow local codes and the national electrical code ANSI/NFPA No. 70.**



**It is strongly suggested that the wiring of the EB-1 Electrical Junction Box be carried out by a licensed electrician.**



**Ensure that the power to the supply line has been disconnected before commencing this procedure.**



The EB-1 Electrical junction box has been fitted standard on this model to allow for the easy connection of an optional fan kit.

To connect the EB-1 box to the house electrical supply follow the steps below.

1. Unscrew retaining screw from EB-1 base plate (Fig. 8) and remove the EB-1 assembly from the appliance.
2. Remove the front cover of the EB box.
3. Remove the plug socket assembly from the EB-1 box.
4. Feed the supply line in through the EB-1 opening in the side of the appliance and then through the back of the EB-1 assembly. (Fig. 6)
5. Connect the black wire of the power supply line to the brass screw (polarized) of the socket assembly.
6. Connect the white wire of the power line to the chrome screw of the socket assembly.
7. Connect the ground wire of the supply line to the green screw of the socket assembly.

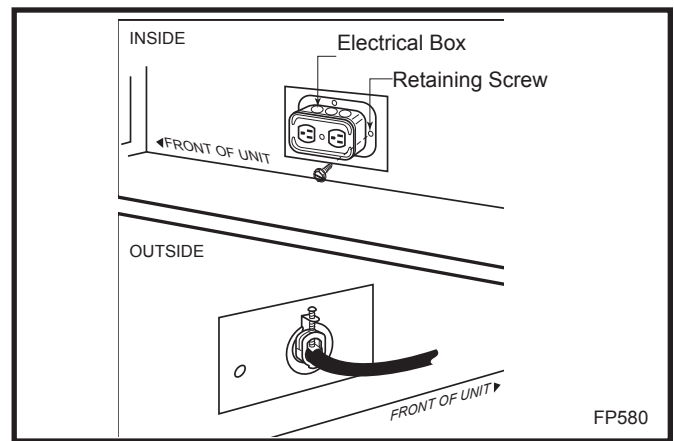

Fig. 6 EB-1 receptacle.

8. Refit the socket assembly back into the electrical box and replace the cover plate. Secure the cable with the clamp on the outside of the EB-1 base plate and refit the EB-1 assembly to the unit with the screw removed in step 1.

## General Venting

Your fireplace is approved to be vented either through the side wall, or vertical through the roof.

- **Only CFM Corporation venting components specifically approved and labelled for this fireplace may be used.**
- Venting terminals shall not be recessed into a wall or siding.
- Horizontal venting which incorporates the twist lock pipe must be installed on a level plane without an inclining or declining slope.
- Horizontal venting which incorporates the use of flex venting shall have an inclining slope from the unit of 1" (25 mm) per 24" (610 mm).

There must not be any obstruction such as bushes, garden sheds, fences, decks or utility buildings within 24" from the front of the termination hood.

Do not locate termination hood where excessive snow or ice build up may occur. Be sure to check vent termination area after snow falls, and clear to prevent accidental blockage of venting system. When using snow blowers, make sure snow is not directed towards vent termination area.

### Location of Vent Termination

It is imperative the vent termination be located observing the minimum clearances as shown on the following page.

### General Venting Information - Termination Location

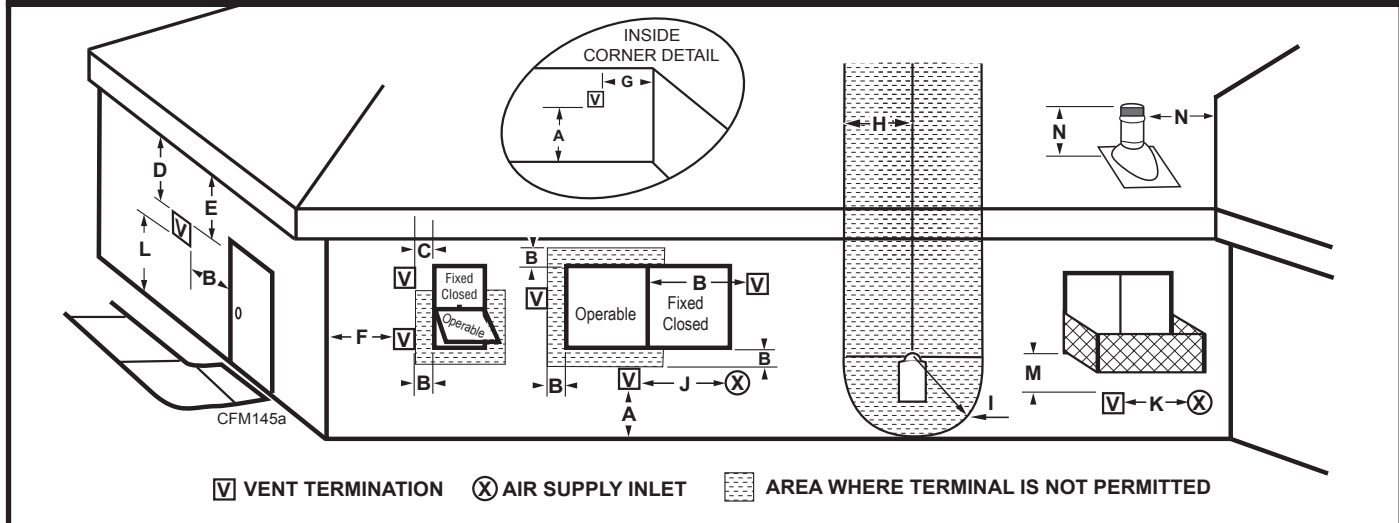

	Canadian Installations <sup>1</sup>	US Installations <sup>2</sup>
A = Clearance above grade, veranda, porch, deck, or balcony	12" (30 cm)	12" (30 cm)
B = Clearance to window or door that may be opened	6" (15 cm) for appliances < 10,000Btuh (3kW), 12" (30 cm) for appliances > 10,000 Btuh (3kW) and < 100,000 Btuh (30kW), 36" (91 cm) for appliances > 100,000 Btuh (30kW)	6" (15 cm) for appliances < 10,000 Btuh (3kW), 9" (23 cm) for appliances > 10,000 Btuh (3kW) and < 50,000 Btuh (15kW), 12" (30 cm) for appliances > 50,000 Btuh (15kW)
C = Clearance to permanently closed window	12" (305 mm) recommended to prevent window condensation	12" (305 mm) recommended to prevent window condensation
D = Vertical clearance to ventilated soffit located above the terminal within a horizontal distance of 2 feet (610mm) from the center line of the terminal	18" (458 mm)	18" (458 mm)
E = Clearance to unventilated soffit	12" (305 mm)	12" (305 mm)
F = Clearance to outside corner	see next page	see next page
G = Clearance to inside corner (see next page)	see next page	see next page
H = Clearance to each inside of center line extended above meter/regulator assembly	3' (91 cm) within a height of 15' above the meter/regulator assembly	3' (91 cm) within a height of 15' above the meter/regulator assy
I = Clearance to service regulator vent outlet	3' (91 cm)	3' (91 cm)
J = Clearance to nonmechanical air supply inlet to building or the combustion air inlet to any other appliances	6" (15 cm) for appliances < 10,000 Btuh (3kW), 12" (30 cm) for appliances > 10,000 Btuh (3kW) and < 100,000 Btuh (30kW), 36" (91 cm) for appliances > 100,000 Btuh (30kW)	6" (15 cm) for appliances < 10,000 Btuh (3kW), 9" (23 cm) for appliances > 10,000 Btuh (3kW) and < 50,000 Btuh (15kW), 12" (30 cm) for appliances > 50,000 Btuh (15kW)
K = Clearance to a mechanical air supply inlet	6' (1.83 m)	3' (91 cm) above if within 10' (3 m) horizontally
L = Clearance above paved sidewalk or paved driveway located on public property	7' (2.13 m)†	7' (2.13 m)†
M = Clearance under veranda, porch, deck or balcony	12" (30 cm)‡	12" (30 cm)‡

N = Clearance above a roof shall extend a minimum of 24" (610 mm) above the highest point when it passes through the roof surface, and any other obstruction within a horizontal distance of 18" (450 mm).

1 In accordance with the current CSA-B149 Installation Codes  
 2 In accordance with the current ANSI Z223.1/NFPA 54 National Fuel Gas Codes  
 † A vent shall not terminate directly above a sidewalk or paved driveway which is located between two single family dwellings and serves both dwellings  
 ‡ only permitted if veranda, porch, deck or balcony is fully open on a minimum 2 sides beneath the floor:  
 NOTE: 1. Local codes or regulations may require different clearances.  
 2. The special venting system used on Direct Vent Fireplaces are certified as part of the appliance, with clearances tested and approved by the listing agency.  
 3. CFM Corporation assumes no responsibility for the improper performance of the appliance when the venting system does not meet these requirements.

Fig. 7 Vent termination clearances.

### Termination Clearances

Termination clearances for buildings with combustible and noncombustible exteriors.

#### Inside Corner

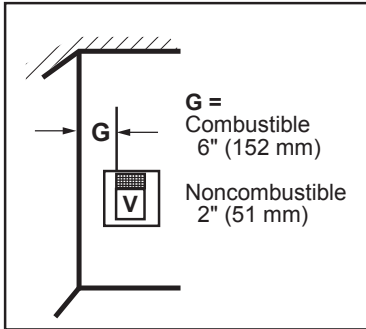

#### Outside Corner

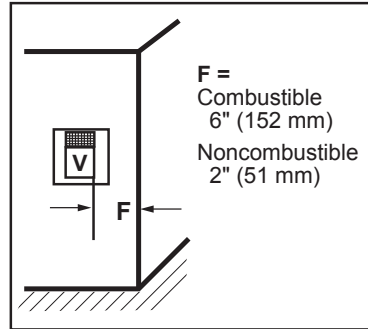

#### Alcove Applications\*

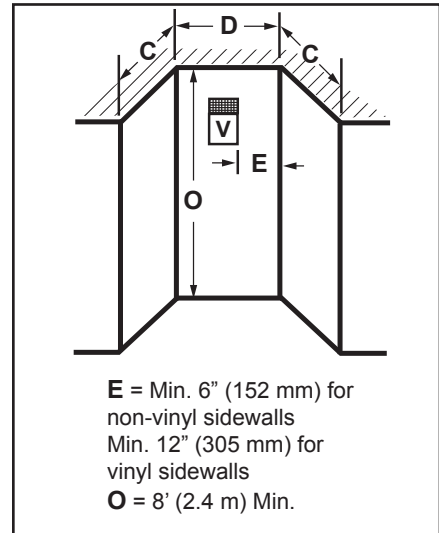

#### Balcony - with no side wall

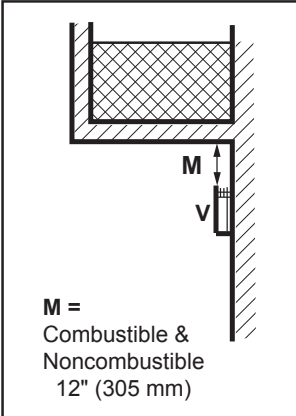

#### Balcony - with perpendicular side wall

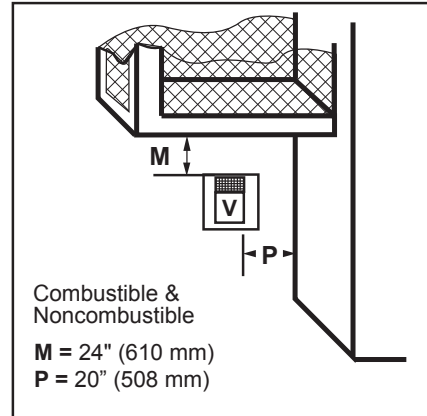

No. of Caps	D <sub>Min.</sub>	C <sub>Max.</sub>
1	3' (914 mm)	2 x D <sub>Actual</sub>
2	6' (1.8 m)	1 x D <sub>Actual</sub>
3	9' (2.7 m)	2/3 x D <sub>Actual</sub>
4	12' (3.7 m)	1/2 x D <sub>Actual</sub>

D<sub>Min.</sub> = # of Termination caps x 3  
 C<sub>Max.</sub> = (2 / # termination caps) x D<sub>Actual</sub>

584-15

**\*NOTE:** Termination in an alcove space (spaces open only on one side and with an overhang) is permitted with the dimensions specified for vinyl or non-vinyl siding and soffits. 1. There must be a 3' (914 mm) minimum between termination caps. 2. All mechanical air intakes within 10' (1 m) of a termination cap must be a minimum of 3' (914 mm) below the termination cap. 3. All gravity air intakes within 3' (914 mm) of a termination cap must be a minimum of 1' (305 mm) below the termination cap.

Fig. 7a Termination clearances.

## General Information on Assembling Vent Pipes

### Canadian Installations:

The venting system must be installed in accordance with the current CSA-B149 .1 installation code.

### USA Installations:

The venting system must conform with local codes and/or the current National Fuel Gas code ANSI Z223.1/ NFPA 54.

Only venting components manufactured by CFM Corporation can be used in Direct Vent systems.

### Flex Vent Pipes

Before joining the flex vent pipe to the unit, apply a bead of high temperature sealant\* (provided) to the 4" pipe exiting the fireplace. Secure flex vent pipe in place with a hose clamp (provided).

\*Be sure the flex pipe overlaps at least 1" (25 mm) onto the collars of the fireplace and termination. If the termination has an internal bead, be sure to overlap and secure 1" (25 mm) past the bead.

\* Be sure the vent is actually crushed before proceeding. Apply a tug to be sure the vent will not slip off the collars.

Repeat process with 7" flex vent pipe. The same procedure must be performed on the vent side.

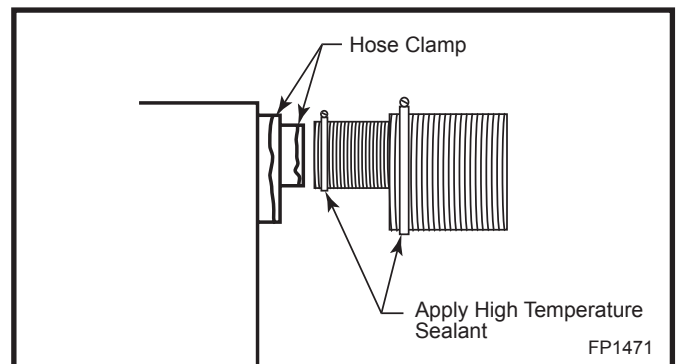

Fig. 8 Apply high temperature sealant to 4" and 7" pipes.

## Twist Lock Pipes

When using CFM Corporation twist-lock pipe it is not necessary to use sealant on the joints. The only areas of the venting system that need to be sealed with high temperature silicone sealant are the collars on the fireplace and termination, and the sliding joint of any telescopic vent section used in the system.

To join the twist lock pipes together, simply align the beads of the male end with the grooves of the female end, then while bringing the ends together, twist the pipe until the flange on the female end contacts the external flange on the male end. It is recommended that you secure the joints with three (3) sheet metal screws, however this is not mandatory with twist lock pipe.

To make it easier to assemble the joints we suggest putting a lubricant (Vaseline or similar) on the male end of the twist lock pipe prior to assembly.

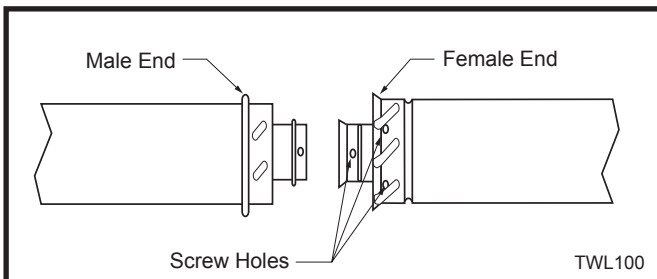

Fig. 9 Twist-lock pipe joints.

## How to Use the Vent Graph

The vent chart should be read in conjunction with the following vent installation instructions to determine the relationship of the vertical and horizontal dimensions of the vent system.

1. Determine the height of the center of the horizontal vent pipe exiting through the outer wall. Using this dimension on the Sidewall Vent Graph (Fig. 10), locate the point intersecting with the slanted graph line.
2. From the point of this intersection, draw a vertical line to the bottom of the graph.
3. Select the indicated dimension, and position the fireplace in accordance with same.

### Example A:

If the vertical dimension from the floor of the fireplace is 11' (3.4 m) the horizontal run to the face of the outer wall must not exceed 14' (4.3 m).

### Example B:

If the vertical dimension from the floor of the unit is 7' (2.14 m), the horizontal run to the face of the outer wall must not exceed 8½' (2.6 m).

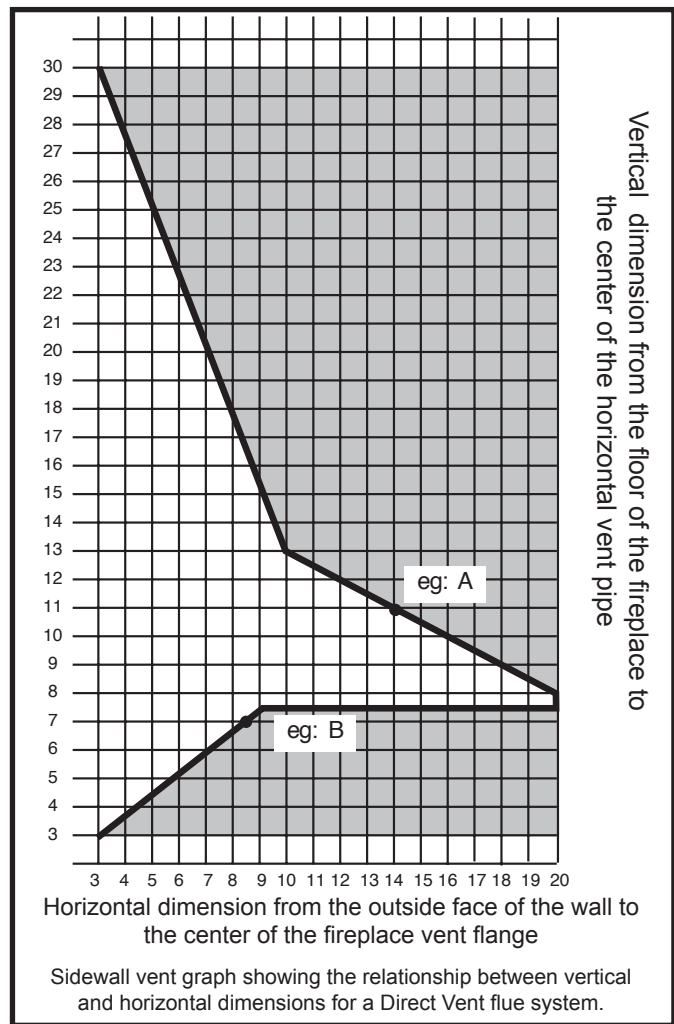

Fig. 10 Sidewall venting graph. (Dimensions in feet)

## Rear Wall Vent Application

When installed as a rear vent unit this appliance may be vented directly to a termination located on the rear wall behind the appliance.

- Only CFM Corporation venting components are approved to be used in these applications (See 'Venting Components' listed for different installation requirements).
- The maximum horizontal distance between the rear of the appliance (or end of the transition elbow in a corner application) and the outside face of the rear wall is 20" (508 mm). (Fig. 11, 12)
- Only one 45° elbow is allowed in these installations.
- Minimum clearances between vent pipe and combustible materials are as follows:

Top - 2" (51 mm)  
Sides - 1" (25 mm)  
Bottom - 1" (25 mm)

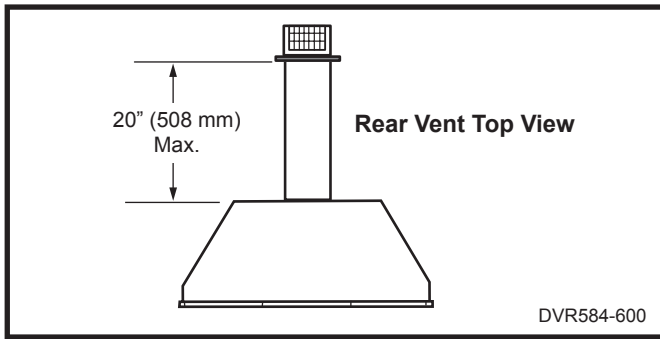

Fig. 11 Rear vent application, no elbows.

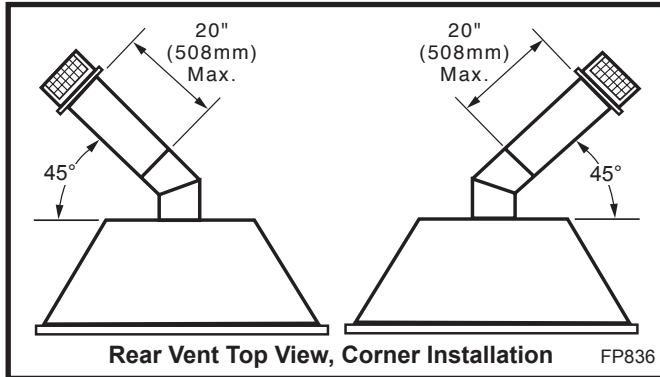

Fig. 12 Rear vent application, one 45° elbow.

**Rear Wall Vent Installation  
Twist Lock Pipe**

**Step 1**

Locate and cut the vent opening in the wall. For combustible walls first frame in opening. (Fig. 13)

**NOTE:** When using flex vent, the opening will have to be measured according to the 1/2" (13 mm) rise in 12" (305mm) vertical run.

**Combustible Walls:** Cut a 10 3/8"H x 9 3/8" W (265 x 240 mm) hole through the exterior wall and frame as shown. (Fig. 13)

**Noncombustible Walls:** Hole opening should be 7 1/2" (191 mm) diameter.



**Zero clearance sleeve is only required for combustible walls.**

**Step 2**

Measure wall thickness and cut zero clearance sleeve parts to proper length (Maximum 12" / 305 mm). Assemble sleeve to its maximum opening (10 3/8" x 9 3/8") and attach to firestop assembly. (Fig. 14)

**Step 3**

Measure the horizontal length requirement for the venting including a 2" (51 mm) overlap, i.e. from the elbow to the outside wall face plus 2" (51 mm). (Fig. 12)

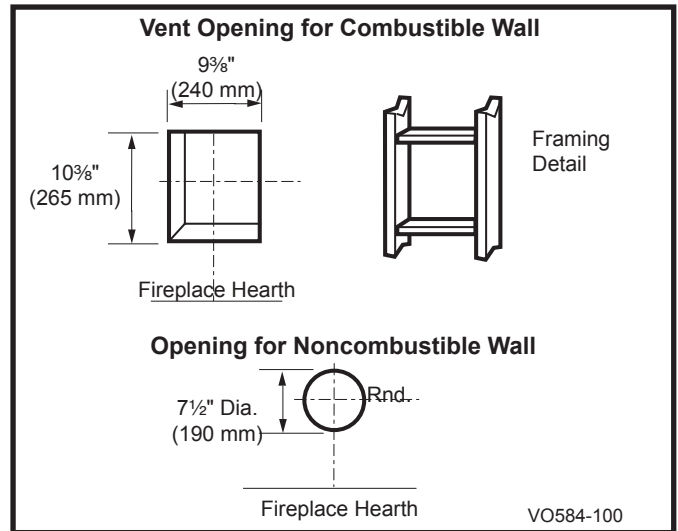

Fig. 13 Locate vent opening on wall.

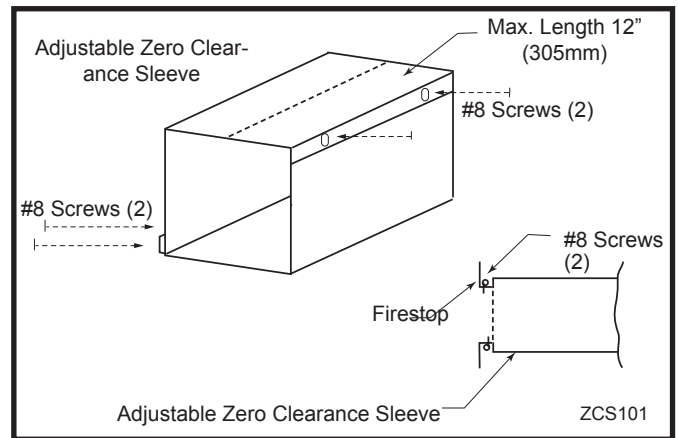

Fig. 14 Adjustable zero clearance sleeve.

**Step 4**

Install the 4" (102 mm) vent to the appliance collar and secure with 3 sheet metal screws. Install the 7" (178 mm) vent pipe to the appliance collar and secure with 3 sheet metal screws. It is not necessary to seal this connection. If a 45° elbow is being used attach the elbow to the appliance in the same manner then attach the venting to the elbow.



**It is critical that there is no downward slope away from the appliance when connecting the vent or elbow.**

**Step 5**

Guide the venting through the vent hole as you place the appliance in its installed position. Guide the 4" (102 mm) and 7" (178 mm) collar of the vent termination into the outer ends of the venting. Do not force the termination. If the vent pipes do not align with the termination, remove and realign the venting at the appliance flue collars. (Fig. 15) Attach the termination to the wall as outlined in the instruction sheet supplied with the termination.

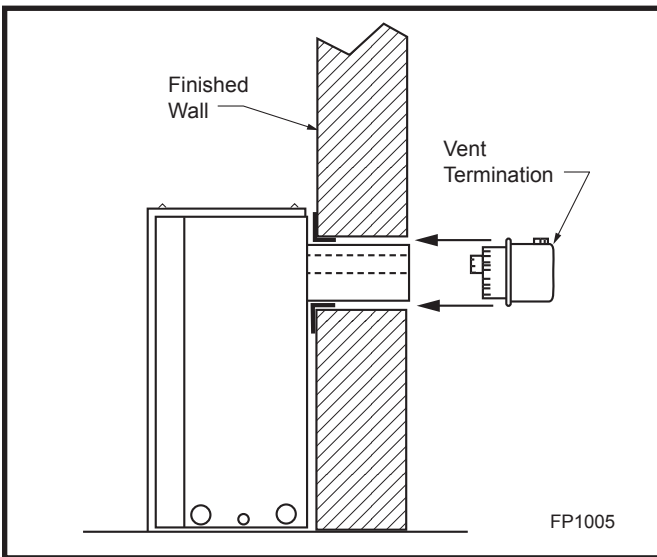

Fig. 15 Side view of final unit location.

### Rear Wall Vent Installation - Flex Vent Pipe

Follow Steps 1 and 2 on Page 13.

#### Step 3

Install the 4" (102 mm) flex vent pipe to the appliance collars described in "General Information Assembling Vent Pipes", Page 10. If the installation requires a 45° angle, grasp the vent pipe close to the appliance collar and bend to 45°. DO NOT exceed 45°. (Fig. 16)

Install the 7" vent pipe in the same manner as Step 2.

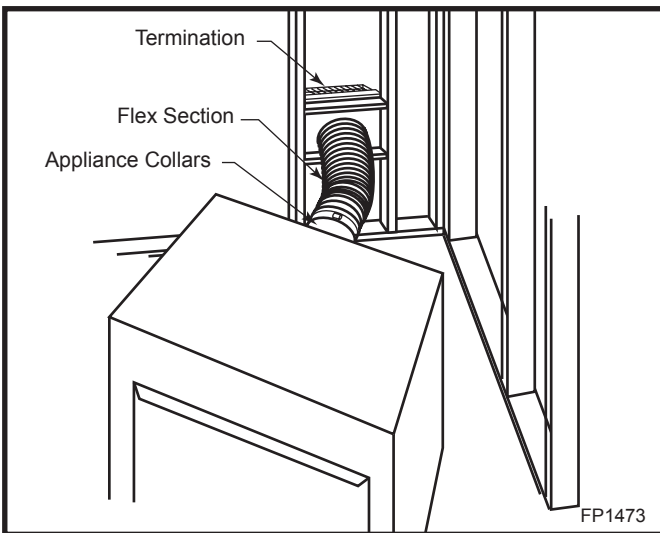

Fig. 16 Grasp the vent pipe close to the collar and bend to 45° angle. Do not exceed 45°.

**NOTE:** There must be a 1/2" (13 mm) rise in a 12" (305 mm) length of flex vent. (Minimum 1" (25 mm) rise.)

#### Step 4

Assemble the flex vent to the collars on the termination as you did on the appliance.

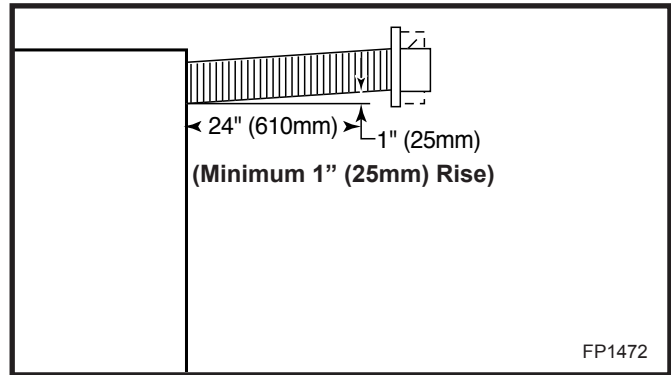

Fig. 17 There must be a 1" rise in 24" length.

### Vertical Sidewall Applications



Since it is very important that the venting system maintain its balance between the combustion air intake and the flue gas exhaust, certain limitations as to vent configurations apply and must be strictly adhered to.

The Vent Graph shows the relationship between vertical and horizontal side wall venting and will help to determine the various dimensions allowable.



Minimum clearance between vent pipes and combustible materials is 1" (25mm) on top, bottom and sides unless otherwise noted.

When vent termination exits through foundations less than 20" below siding outcrop, the vent pipe must flush up with the siding. It is always best to locate the fireplace in such a way that minimizes the number of offsets and horizontal vent length.

The horizontal vent run refers to the total length of vent pipe from the flue collar of the fireplace to the face of the outer wall.

Horizontal plane means no vertical rise exists on this portion of the vent assembly.

- The maximum horizontal vent run is 20 ft. (6.1 m) when the vertical vent rise is 7½ ft. (2.3 m). (Fig. 18)
- The maximum number of 90° elbows per side wall installation is three (3).
- If a 90° elbow is used in the horizontal vent run (level height maintained) the maximum horizontal vent length is reduced by 36" (914 mm). (Fig. 19) This does not apply if the 90° elbows are used to increase or redirect a vertical rise. (Fig. 20)

Example: According to the chart the maximum horizontal vent length in a system with a 7.5' (2.3 m) vertical rise is 20' (6 m) and if a 90° elbow is required in the horizontal vent it must be reduced to 17' (5.2 m). In Figure 19 Dimension A plus B must not be greater than 17' (5.2 m).

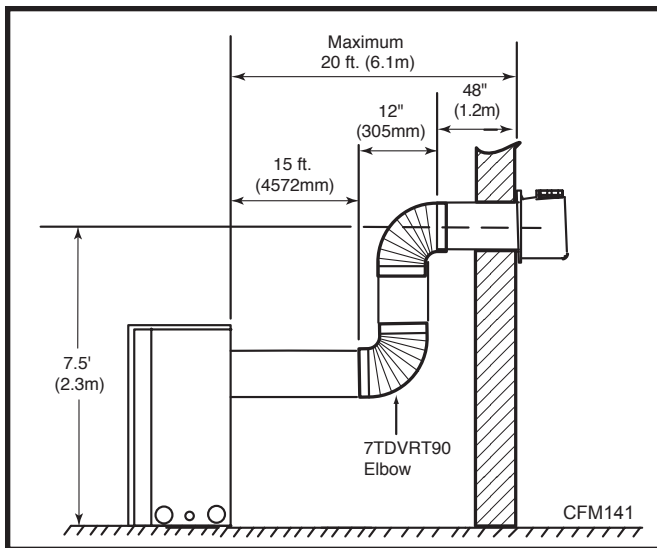

Fig. 18 Maximum number of 90° elbows is three (3).

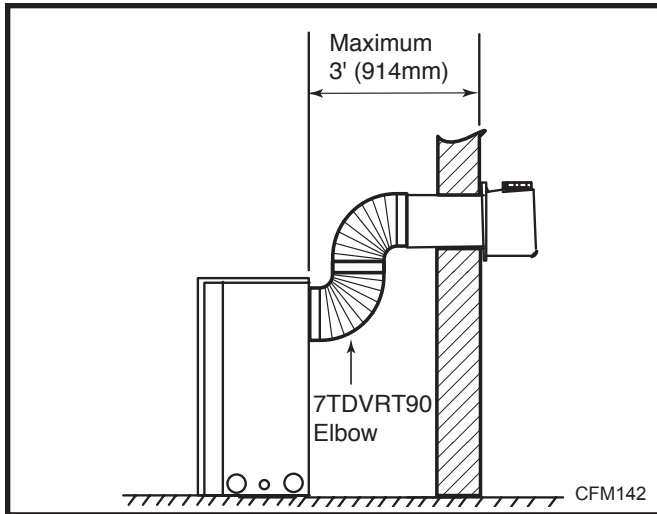

Fig. 19 Maximum horizontal vent run.

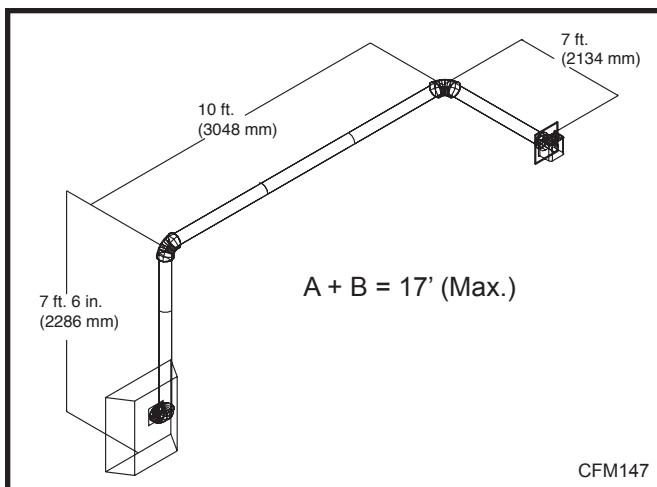

Fig. 20 Maximum vent run with elbows.

- The maximum number of 45° elbows permitted per side wall installation is two (2). These elbows can be installed in either the vertical or horizontal run.
- For each 45° elbow installed in the horizontal run, the length of the horizontal run MUST be reduced by 18" (45cm). This does not apply if the 45° elbows are installed on the vertical part of the vent system.
- The maximum number of elbow degrees in a system is 270°. (Fig. 21)

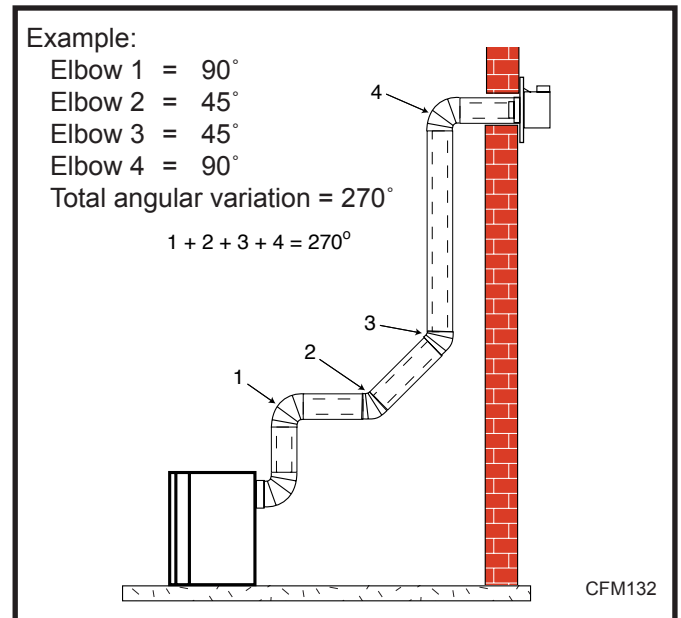

Fig. 21 Maximum number of elbow degrees.

• **IMPORTANT** •

Minimum clearance between vent pipes and combustible materials is one (1") inch (25 mm) on bottom, sides and top.

**Twist Lock Vent Starter Kit 7TDVSK, plus Transition Elbow 7TDVRT90 must be used in Vertical Sidewall installations. The 4" pipe must be centered inside the 7" pipe coming off the transition elbow.**

**Canadian & USA Installations:**

The venting system must conform with local codes, or in the absence of local codes, with National Fuel Gas Code, ANSI Z223.1/NFPA 54 - latest edition, or CSA B149.1 Installation Code.

Only CFM Corporation venting components specifically approved and labelled for this fireplace may be used.

## Vertical Sidewall Installation Twist Lock Pipe

### STEP 1

Locate vent opening on the wall. It may be necessary to first position the fireplace and measure to obtain hole location. Depending on whether the wall is combustible or noncombustible, cut opening to size. (Fig. 22) For combustible walls first frame in opening.

**NOTE:** When using flex vent, the opening will have to be measured according to the 1" (25 mm) rise in 24" (610mm) vent run. (Minimum 1" (25 mm) rise)

**Combustible Walls:** (Fig. 22) Cut a 9 $\frac{3}{8}$ "H x 9 $\frac{3}{8}$ "W (240 x 240 mm) hole through the exterior wall and frame as shown.

**Noncombustible Walls:** (Fig. 22) Hole opening must be 7 $\frac{1}{2}$ " (190 mm) in diameter.

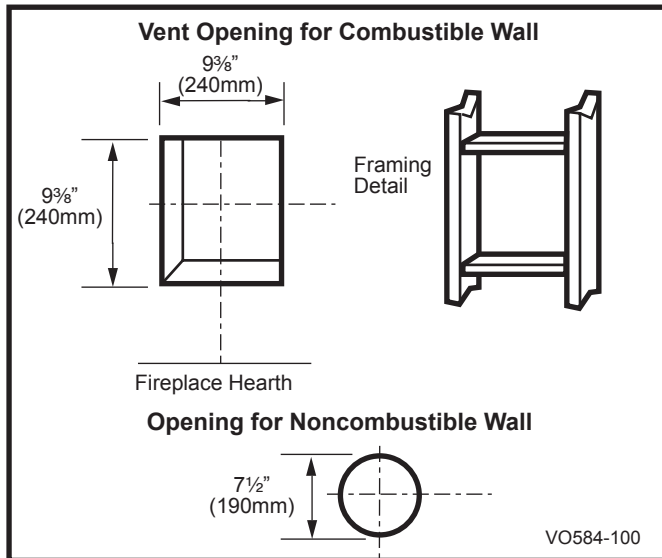

Fig. 22 Locate vent opening on wall.

### STEP 2

Measure wall thickness and cut zero clearance sleeve parts to proper length (MAXIMUM 12"/305 mm). Assemble sleeve and attach to firestop with #8 sheet metal screws (supplied). Install firestop assembly. (Fig. 23)



**Zero clearance sleeve is only required for combustible walls.**

### STEP 3

Apply a bead of high temperature sealant to the inner and outer flue collars of the fireplace and using appropriate venting component(s), attach to fireplace with three (3) screws. (Fig. 24) Follow with the installation of the inner and outer elbow. Again secure joints with three (3) sheet metal screws. Wipe off any excess high temperature sealant.

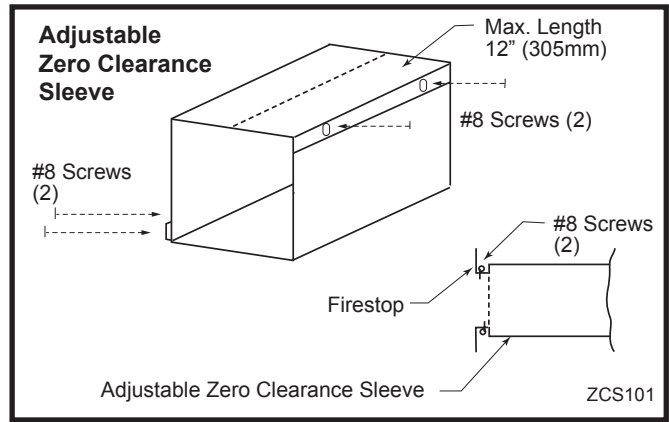

Fig. 23 Adjustable zero clearance sleeve.

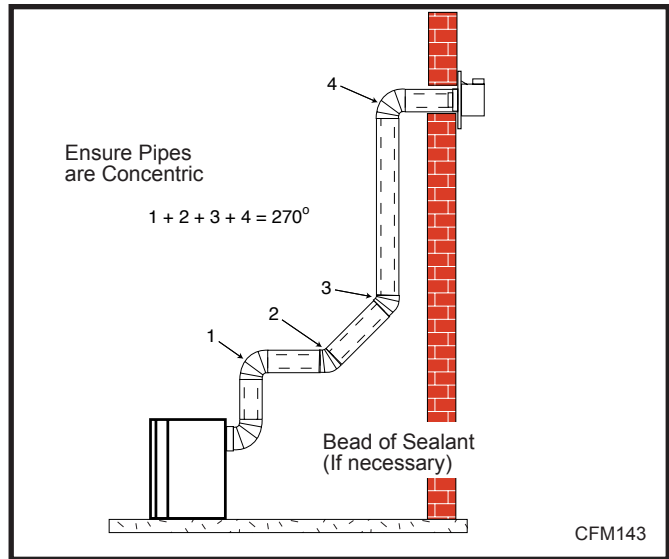

Fig. 24 Apply sealant to inner and outer pipe.

### STEP 4

Measure the horizontal length requirement including a 2" (51 mm) overlap, i.e. from the elbow to the outside wall finish plus 2", or the distance required if installing a second 90° elbow. (Fig. 25)

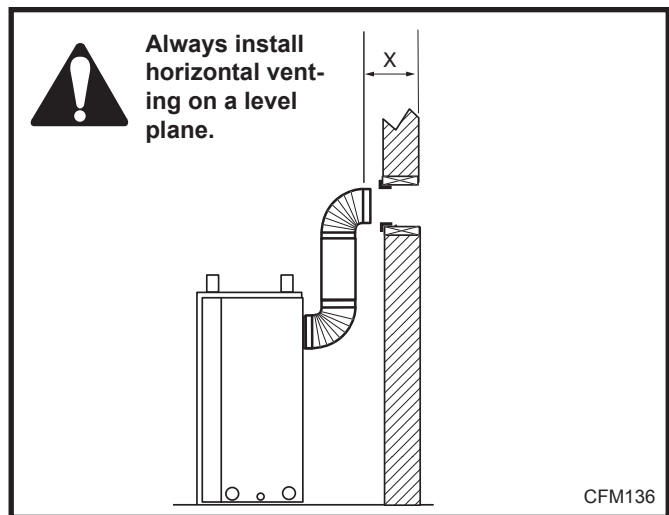

Fig. 25 Measure horizontal length including 2" overlap.



**STEP 5**

Use appropriate length of pipe section - telescopic or fixed - and install the horizontal vent sections. The 20" (508 mm) section of pipe which goes through the wall is packaged with the 7TDVSK starter kit, and can be cut to suit if necessary. (Fig. 26)



**Sealing vent pipe and firestop gaps with high temperature sealant will restrict cold air being drawn in around fireplace.**

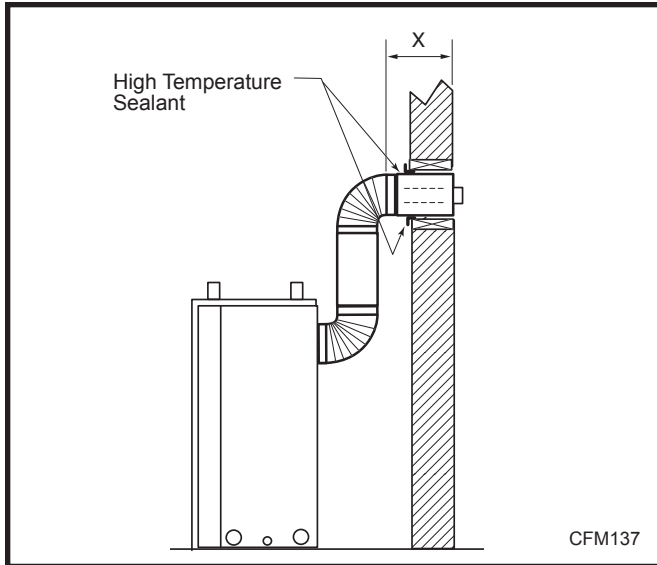

**Fig. 26** Apply high temperature sealant.

**STEP 6**

Apply high temperature sealant to 4" (102 mm) and 7" (178 mm) collars or the termination one inch away from the end. Guide the vent termination's 4" and 7" collars into their respective vent pipes. Double check that the vent pipes overlap the collars by 2" (51 mm). Secure the termination to the wall with screws provided and caulk around the wall plate to weatherproof. (Fig. 27)

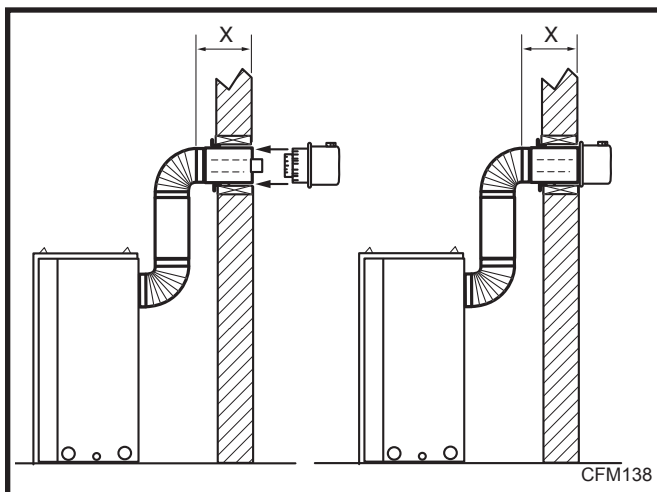

**Fig. 27** Horizontal length requirement.

**Vertical Sidewall Installation  
Flex Vent Pipe**

Follow Step 1 and 2 on Page 15.

**Step 3**

Install the four (4) spacer springs on the 4" flex vent pipe. When installing the spacer springs around the 4" pipe, stretch the spring to approximately 15" (381 mm), wrap the spring around the pipe and interlock the ends of the spacer spring approximately 2" (51 mm). (Fig. 28) Measure 8" (203 mm) from the end of the pipe. Place the next spring 8" (203 mm) from the previously installed spring. Place the next spring approximately 8" (203 mm) from the last spring. Finally place the last spring approximately 8" (203 mm) from the last spring installed. (Fig. 29) Maintain equal spacing between spacer springs.

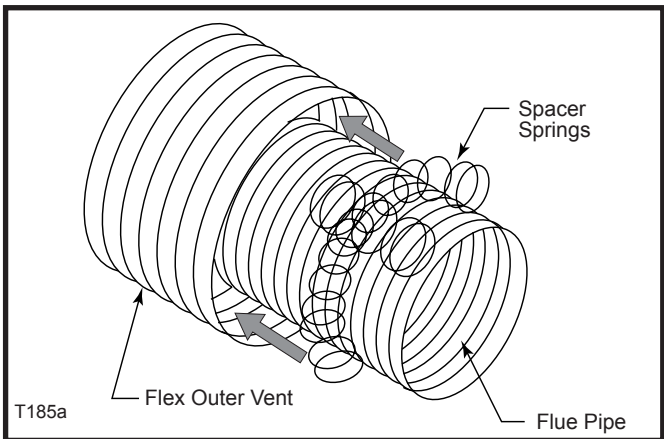

**Fig. 28** Wrap spacer spring around flex flue pipe, overlapping ends.

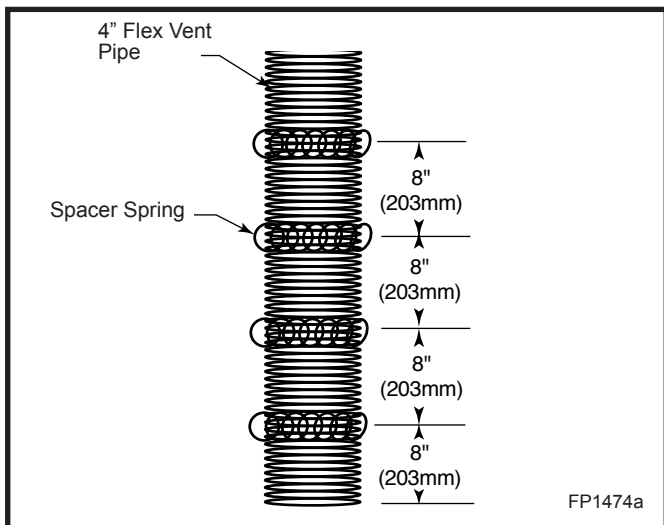

**Fig. 29** Install spacer springs.

**Step 4**

Install the 4" (102 mm) flex vent pipe to the termination cap collar as described on Page 11.

**Step 5**

Slide the 7" (178 mm) flex vent pipe over the 4" flex vent pipe and secure the 7" collar as described on Page 11.

**Step 6**

Be sure to follow the 1" (25 mm) rise in a 24" (610 mm) horizontal run rule. Trim off excess vent material, then install the 4" flex to the flue collar and the 7" flex to the appliance collar. Secure venting with band clamps provided. Refer to Page 11, Figure 8.

### Below Grade Installations

When it is not possible to meet the required vent terminal clearances of 12" (305 mm) above grade level a snorkel vent kit is recommended. It allows installation depth of down to 7" (178 mm) below grade level. The 7" is measured from the center of the horizontal vent pipe as it penetrates through the wall.



**If venting system is installed below ground, we recommend a window well with adequate and proper drainage.**

**Ensure sidewall venting clearances are observed.**

If installing a snorkel a minimum 24" (610 mm) vertical rise is necessary. The maximum horizontal run with the 24" (610 mm) vertical pipe is 36" (914 mm). This measurement is taken from the collar of the fireplace (or transition elbow) to the face of the exterior wall. Refer to the Sidewall Vent Graph for extended horizontal run if the vertical rise exceeds 24" (610 mm).

1. Establish vent hole through the wall. (Page 16, Fig. 22)
2. Remove soil to a depth of approximately 16" (406 mm) below base of snorkel. Install drain pipe. Install window well (not supplied). Refill hole with 12" (305 mm) of coarse gravel leaving a clearance of approximately 4" (102 mm) below snorkel. (Fig. 30)
3. Install vent system.
4. Ensure a watertight seal is made around the vent pipe coming through the wall.
5. Apply high temperature sealant caulking (supplied) around the 4" and 7" snorkel collars.
6. Slide the snorkel into the vent pipes and secure to the wall.
7. Level the soil to maintain a 4" (102 mm) clearance below snorkel. (Fig. 30)

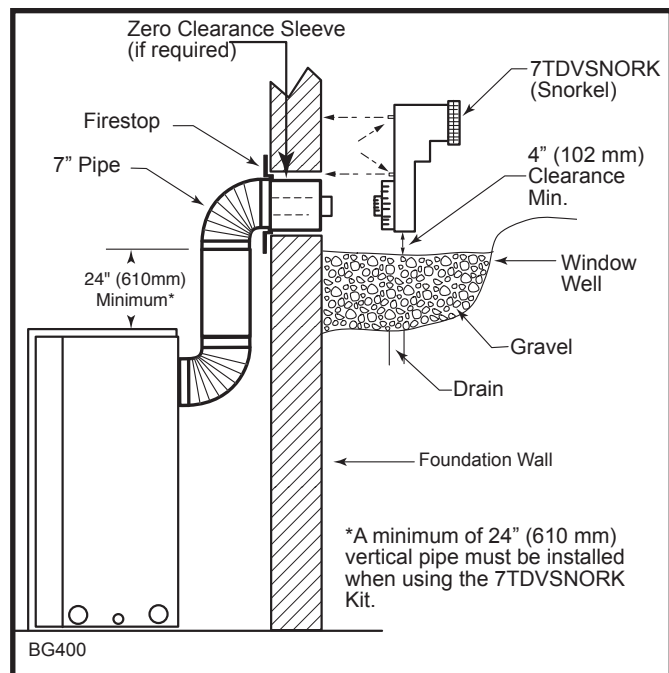
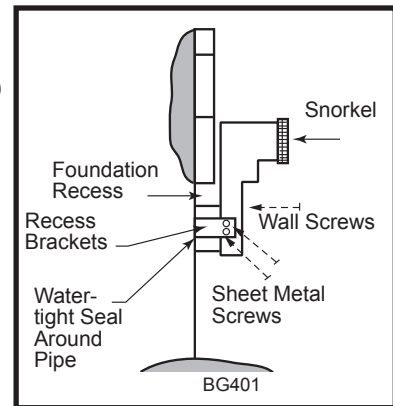

**Fig. 30** Below grade installation.



**Do not back fill around snorkel. A clearance of at least 4" (102 mm) must be maintained between snorkel and the soil.**

If the foundation is recessed, use recess brackets (not supplied) for securing lower portion of the snorkel. Fasten brackets to wall first, then secure to snorkel with self drilling #8 x 1/2 sheet metal screws. It will be necessary to extend vent pipes out as far as protruding wall face. (Fig. 31)



**Fig. 31** Snorkel installation, recessed foundation.

## Vertical Through-the-Roof Applications

This Gas Fireplace has been approved for:

- Vertical installations up to 40' (12 m) in height. Up to a 10' (3 m) horizontal vent run can be installed within the vent system using a maximum of two 90° elbows. (Fig. 32)

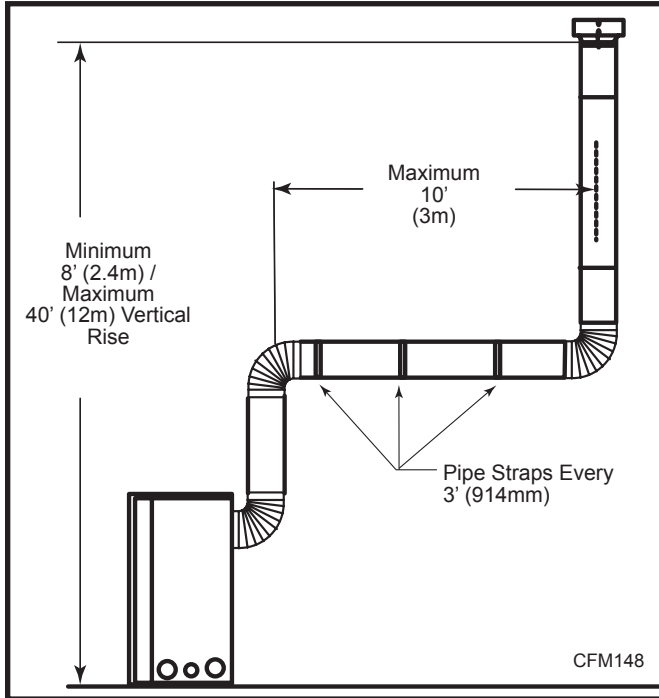

Fig. 32 Support straps for horizontal runs.

- Up to two 45° elbows may be used within the horizontal run. For each 45° elbow used on the horizontal level the maximum horizontal length must be reduced by 18" (457 mm).  
Example: Maximum horizontal length  
0 x 45° elbows = 10' (3 m)  
1 x 45° elbows = 8½' (2.6 m)  
2 x 45° elbows = 7' (2.1 m)
- A minimum of an 8' (2.4 m) vertical rise.
- Two sets of 45° elbows offsets within these vertical installations. From 0 to a maximum of 8' (2.4 m) of vent pipe can be used between elbows. (Fig. 33)
- 7DVCS must be used to support offsets. (Fig. 33) This application will require that you first determine the roof pitch and use the appropriate starter kit. (Refer to Venting Components List)
- The minimum height of the vent above the highest point of penetration through the roof is 2' (610 mm). (Fig. 34)

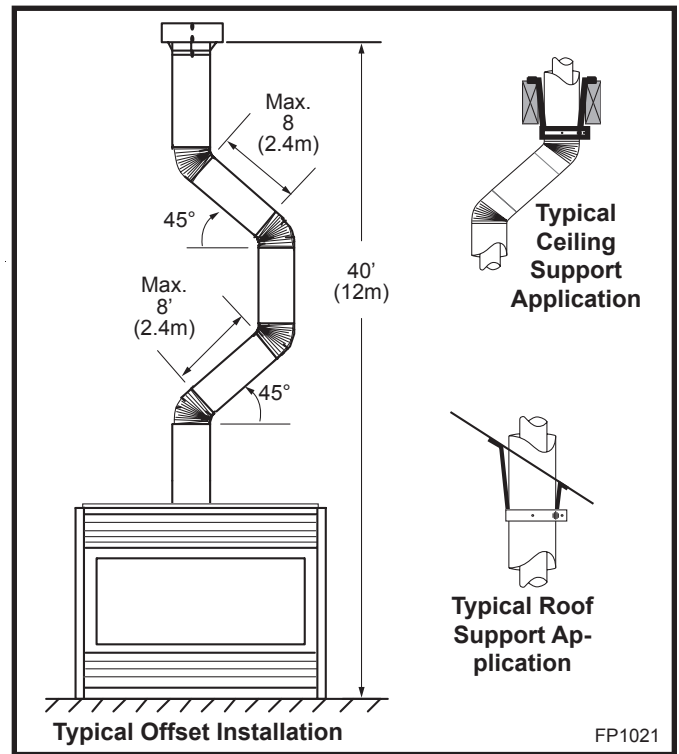

Fig. 33 Typical offset application.

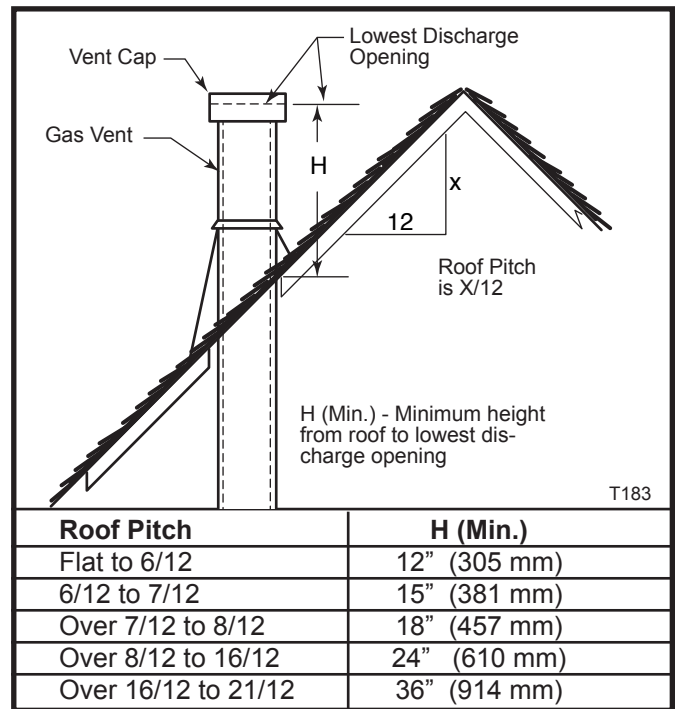

Fig. 34 Vertical termination location.

## Vertical Through-the-Roof Installation

1. Locate your fireplace.
2. Plumb to center of the (4" (102 mm) flue collar from ceiling above and mark position.
3. Cut opening equal to 9 $\frac{3}{8}$ " x 9 $\frac{3}{8}$ " (240 x 240 mm).
4. Proceed to plumb for additional openings through the roof. In all cases, the opening must provide a minimum of 1" (25 mm) clearance to the vent pipe, i.e., the hole must be at least 9 $\frac{3}{8}$ " x 9 $\frac{3}{8}$ " (240 x 240 mm).
5. Place fireplace into position.
6. Place firestop(s) #7DVFS or Attic Insulation Shield #7DVAIS into position and secure. (Fig. 35)
7. Install roof support (Fig. 33) and roof flashing making sure upper flange of flashing is below the shingles. (Fig. 36)
8. Install appropriate pipe sections until the venting is above the flashing. (Fig. 36)
9. Install storm collar and seal around the pipe.
10. Add additional vent lengths for proper height. (Fig. 37)
11. Apply high temperature sealant to 4" and 7" collars.



**If there is a room above ceiling level, firestop spacer must be installed on both the bottom and the top side of the ceiling joists. If an attic is above ceiling level a 7DVAIS (Attic Insulation Shield) must be installed.**

**The enlarged ends of the vent section always face downward. (Fig. 36)**

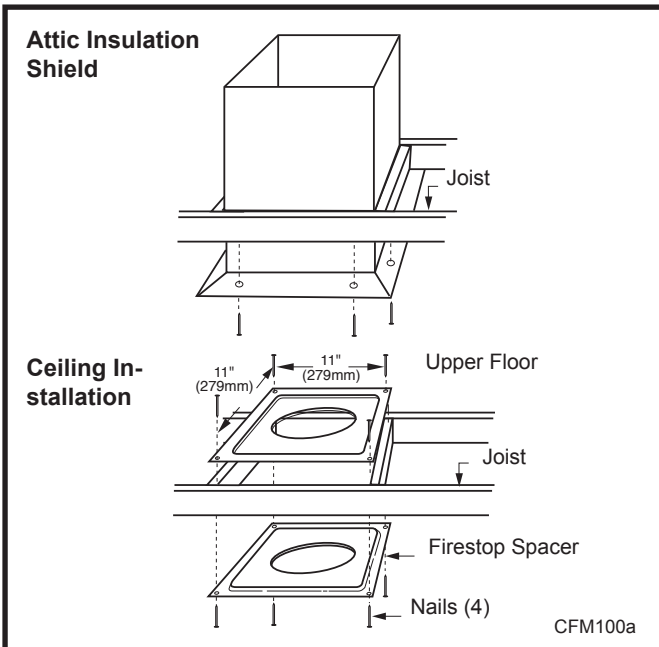

Fig. 35 Place firestop spacer(s) and secure.

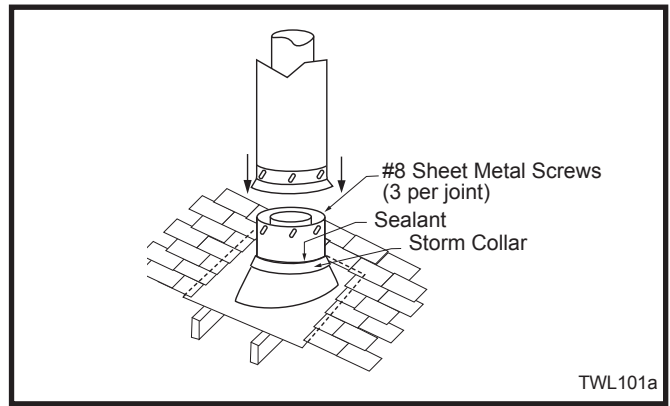

Fig. 36 Roof flashing.

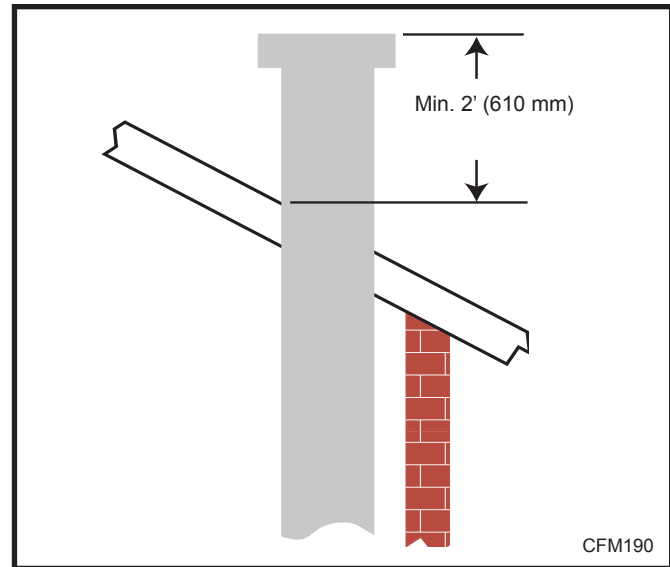
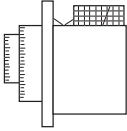
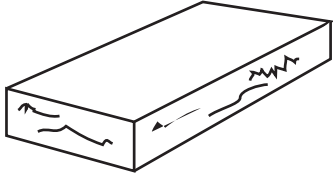

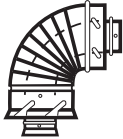
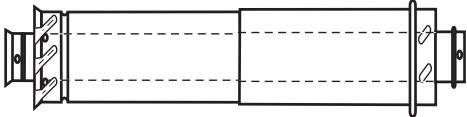
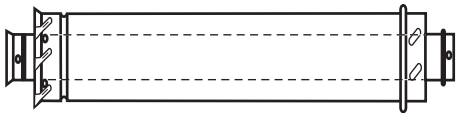
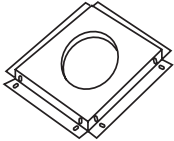
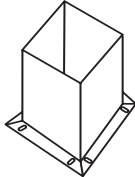
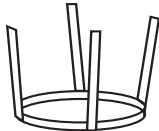

Fig. 37 Minimum termination to roof clearance.

**Venting Components**

	<p>7TDVSK - Through the wall Rear Vent Termination</p>
	<p>Starter Kit -                      Model 7TDVSK - Sidewall Venting (Twist Lock Pipe)                      Model 7FDVSK - Sidewall Venting (Flex Vent Pipe)</p> <p>Starter Kit - Model 7TDVSKV - Vertical Venting                      for 7TDVSKV-A order 1/12 to 6/12 roof pitch                      for 7TDVSKV-B order 7/12 to 12/12 roof pitch                      for 7TDVSKV-F order flat roof</p> <p>Starter Kit for Below Grade Installation                      Model 7TDVSKS -Snorkel Kit (Twist Lock Pipe)                      Model 7FDVSKS -Snorkel Kit (Flex Vent Pipe)</p>
	<p>45° Elbow                      7TDV45 for Rear Vent to Vertical Vent                      or Vertical/Horizontal Offsets</p>
	<p>90° Transition Elbow                      7TDVRT90 for Rear Vent to Vertical Vent                      90° Elbow                      7TDV90 Vertical/Horizontal Offset</p>
	<p>Telescopic vent sections                      7TDVP1117 -11" to 17" adjustable length                      7TDVP3567 -35" to 67" adjustable length</p>
	<p>Pipe sections for vertical or horizontal venting                      Model 7TDVP8" - 4 per box                      Model 7TDVP12" - 4 per box                      Model 7TDVP24" - 4 per box                      Model 7TDVP36"                      Model 7TDVP48"</p>
	<p>Firestop Spacer                      Model 7DVFS</p>
	<p>Attic Insulation Shield                      Model 7DVAIS</p>
	<p>Vertical/Horizontal Combination Offset Support                      Model 7DVCS</p>

## Operating Instructions

### Glass Information



**Only glass approved by CFM Corporation should be used on this fireplace.**

- The use of any non-approved replacement glass will void all product warranties.
- Care must be taken to avoid breakage of the glass.
- **Do not operate appliance with glass front removed, cracked or broken.**
- **Replacement glass (complete with gasket) is available through your CFM Corporation dealer and should only be installed by a licensed qualified service person.**

### ! WARNING



**HOT GLASS WILL CAUSE BURNS.**  
**DO NOT TOUCH GLASS UNTIL COOLED.**  
**NEVER ALLOW CHILDREN TO TOUCH GLASS.**

### Louvre Removal

The top louvre panel is removed by lifting the panel vertically and pulling it away from the appliance. (Fig. 38)

The lower access door is hinged along the bottom edge and is folded down to allow access.

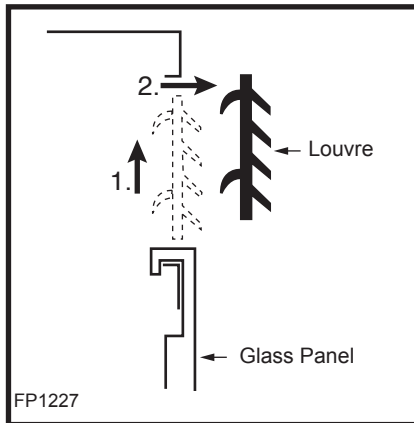

Fig. 38 Remove top louvre assembly.

### Window Frame Removal

1. Turn the fireplace OFF (including the pilot)
2. If the unit has been operating allow time for the components to cool.
3. Remove the top louvre assembly.
4. Open the lower louvre panel.
5. Release the two clamps securing the lower edge of the frame by pulling down on the handles. (Fig. 39)
6. Tilt the glass frame out slightly at the bottom, lift the frame up and away from the fireplace.
7. To replace the glass frame reverse the procedure.

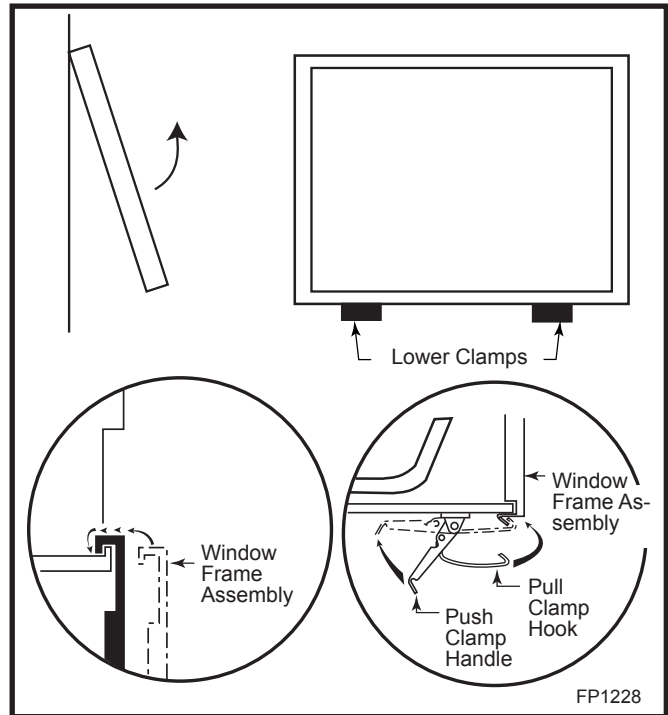

Fig. 39 Window frame assembly removal.

### Glass Cleaning

It is necessary to periodically clean the glass. During start-up condensation, which is normal, forms on the inside of the glass. This condensation causes lint, dust and other airborne particles to cling to the glass surface.

Also initial paint curing may deposit a slight film on the glass. It is therefore recommended that the glass be cleaned two or three times with a non-ammonia based household cleaner and warm water (We recommend gas fireplace glass cleaner) within the first few weeks of operation.

After the initial cleaning process the glass should be cleaned two or three times during each operating season depending on the environment in the house.



**Clean the glass after the first two weeks of operation.**

**Do not clean glass when hot.**

**Do not use abrasive cleaners.**

**Do not strike or slam glass.**

## Installation of Logs, Lava Rock & Ember Material

Unpack the logs from packaging and remove each log from its wrapping materials.



**The logs are fragile and should be handled with care. Keep the packaging material out of the reach of children and dispose of the material in a safe manner.**



**The embers supplied with your fireplace are made from a high grade rock wool and should be handled carefully. Wash your hands immediately after touching to avoid irritation. The embers must be placed correctly in order to function properly.**

### Log Installation - 33RDVDSN

1. Open glass door (if installed).
2. Remove logs from the packaging. (As with all plastic, these bags are not toys and should always be kept away from children and infants.)
3. Place rear log on back bracket. Ensure that log is firmly positioned and there is no side-to-side movement.
4. Place the front log on the front burner (starting toward the rear of the front burner) and slide it forward until the notches lock into place.
5. Place the top logs onto the locator notches. Ensure that the logs are secure. (Fig. 40)

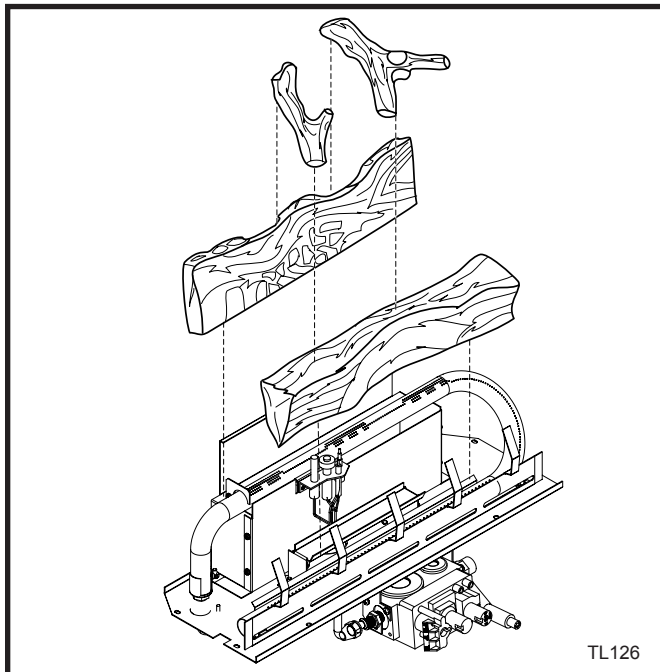

Fig. 40 33RDVDSN log placement.

### Log Installation - 36/39RDVDSN

**Attention:** Glass door should be removed when installing logset and prior to lighting the unit.

1. Remove glass door (Refer to "Window Frame Removal").
2. Remove logs from carton and inspect. Refer to Figure 41.
3. Rear log should be installed onto rear log supports. Match up slots on rear of log with the vertical log bracket tabs. Push log back as far as it will go.
4. The front log should be placed on the front log supports, slots aligned with tabs and log bottom in channel.
5. Top twigs can then be placed in their designated positions provided with pins on back logs and grooves on the front log. Front log must be upright.

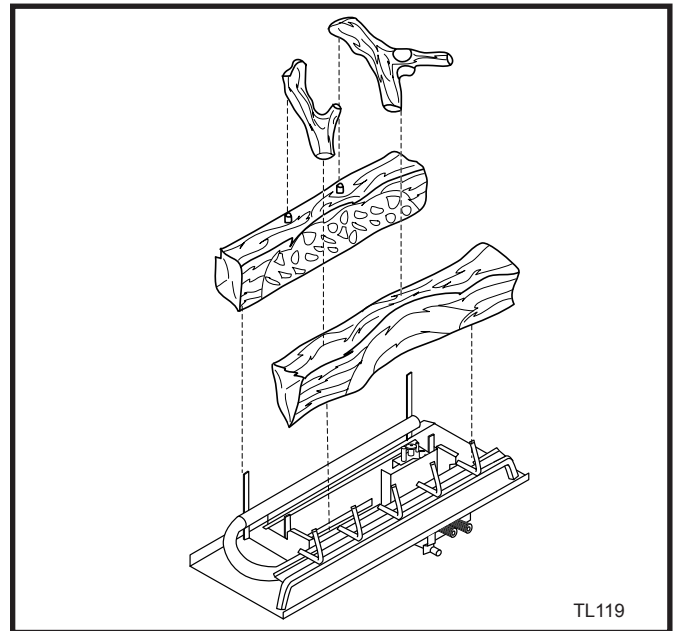

Fig. 41 Correct log placement for 36/39RDVDSN.

### All Models

6. Place platinum embers loosely along top surface of burner along entire length of ported area of front burner. DO NOT place embers on back portion of burner. Use individual pieces of embers no larger than dime size, about 1/16" thick (fluffed up thickness). Use a single layer of embers and DO NOT overlap pieces. Ember material should be fluffed up and not compressed. When properly placed, all embers will glow red. Adding more embers than necessary will detract from appearance.
7. Ember tray ends beyond burner port area and area in front of grate may be covered with lava rock to suit individual appearance preferences.

8. Purge lines and test pilot operation.
9. Replace glass door. The door must be installed before operating the fireplace.
10. Flame should not impinge (touch) on logs.



**WARNING:** Do not place lava rock or any other materials on the burner. Use only certified material supplied with this fireplace. Using uncertified materials will void the warranty.

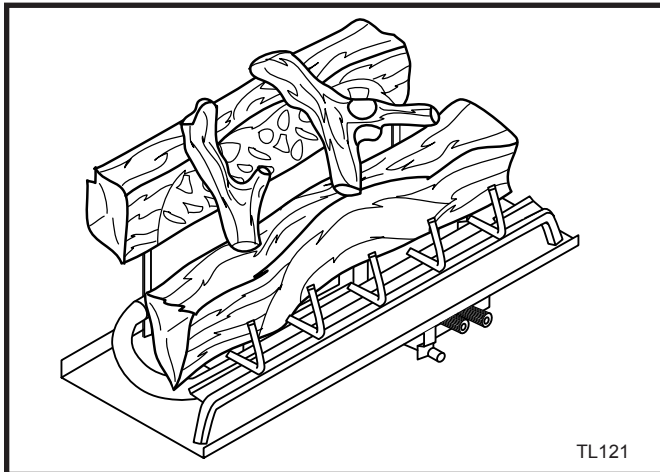

Fig. 42 Logs in final position.

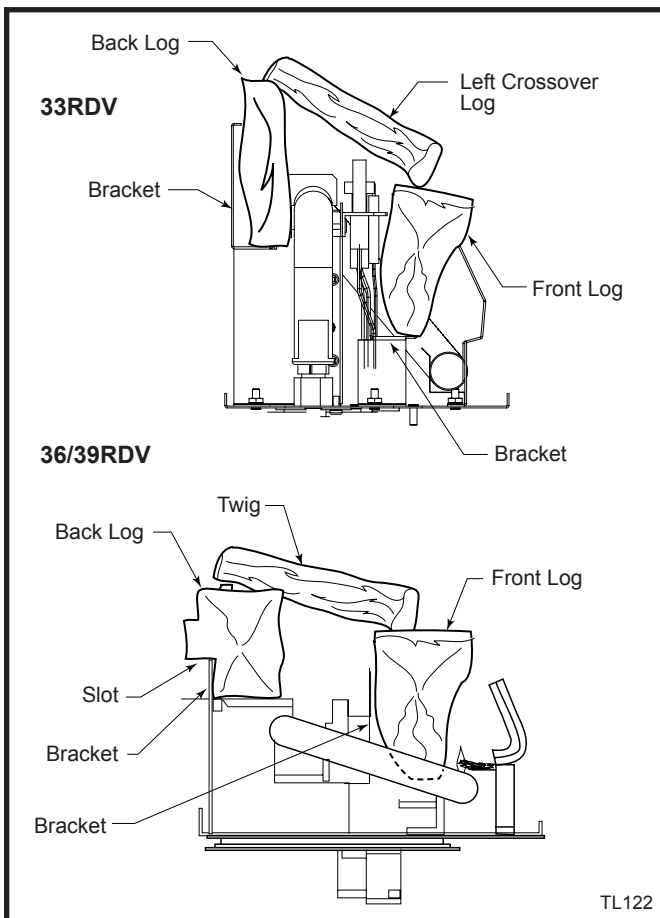

Fig. 43 Side view of logset.

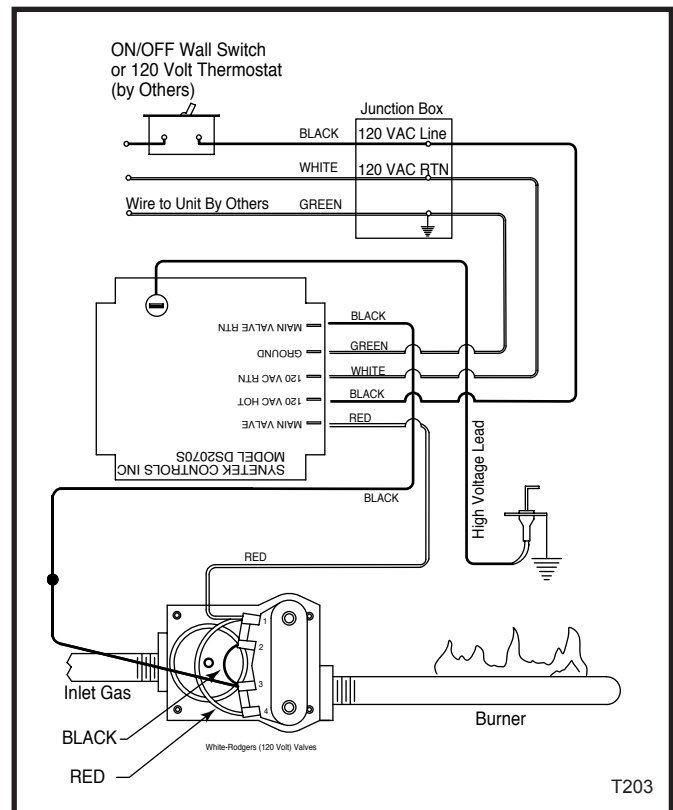

Fig. 44 Electronic ignition module wiring diagram.



# Lighting and Operating Instructions

## FOR YOUR SAFETY READ BEFORE LIGHTING

**WARNING:** If you do not follow these instructions exactly, a fire or explosion may result causing property damage, personal injury or loss of life.

- A. This heater has a pilot which must be lit manually. When lighting the pilot follow these instructions exactly.
- B. BEFORE LIGHTING smell all around the heater area for gas. Be sure to smell next to the floor because some gas is heavier than air and will settle on the floor.

### WHAT TO DO IF YOU SMELL GAS

- Do not try to light any fireplace
  - Do not touch any electric switch
  - Do not use any phone in your building
  - Immediately call your gas supplier from a neighbor's phone. Follow the gas supplier's instructions.
- If you cannot reach your gas supplier, call the Fire Department
- C. Use only the wall switch or remote control switch to turn the gas control on/off. Never use tools. If the knob will not push in or turn by hand, do not try to repair it, call a qualified service technician. Applying force or any attempted repair may result in a fire or explosion.
- D. Do not use this fireplace if any part has been under water. Immediately call a qualified service technician to inspect the heater and to replace any part of the control system and any gas control which has been under water.

## Lighting Instructions

1. **STOP!** Read the safety information above.
2. Set the thermostat, if used, to the lowest setting.
3. Turn off electric power to the appliance.
4. This appliance is equipped with an ignition device which automatically lights the burner. Do not try to light the burner by hand.

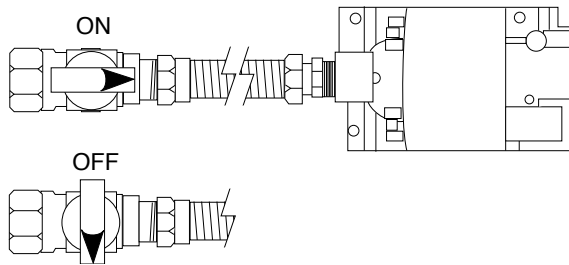

5. Open the access door located at the bottom of the appliance to expose the controls.
6. Turn gas line valve to "ON".
7. Wait five (5) minutes to clear out any gas, then smell for gas, including near the floor. If you smell gas, **STOP!** Follow "B" in the safety information above. If you do not smell gas, go to the next step.
8. Replace control access panel.
9. Turn on all electric power to the appliance.
10. Set thermostat to desired setting (if available).
11. If the appliance will not operate, follow the instructions "To Turn OFF Gas to Appliance" and call your service technician or gas supplier.

## To Turn Off Gas to Heater

1. Set thermostat to lowest setting.
2. Turn off all electric power to the appliance if service is to be performed.
3. Open the control access door.
4. Turn gas line valve to the "OFF" position.
5. Close the control access door.

## Troubleshooting

**NOTE:** Before troubleshooting the gas control system, be sure external shut off is in the “ON” position.



**WARNING:** Before doing any gas control service work, remove glass front!

Problem	Possible Cause	Solution
No gas to main burner	Low gas pressure to the appliance.	With the main burner functioning, adjust the inlet pressure regulator to supply gas to the appliance within the design parameters of the appliance manufacturer. (Typically 7”NG, 11”LPG)
	Gas line valve not in ON position.	Rotate OFF/ON gas line valve to the ON position.
Thermostat/wall switch	Thermostat not in ON position.	Turn thermostat ON, and adjust temperature control to call for heat.
	Defective thermostat or thermostat wiring.	Replace thermostat or wiring.
Thermostat/wall switch	Defective wall switch.	Repeat the above troubleshooting items covered under will not cycle main “Defective thermostat or thermostat wiring”, except substitute the words “wall switch” where the word thermostat appears in the instructions.
	Excessive wire resistance.	Make certain all connections are made using wire of the proper size.
	Valve wired wrong.	Refer to wiring diagram on Page 23.
No spark when system is turned to “ON” and reset cycle* has been completed.	Check for 120V between black “hot” line at control module and “white” return at module.	If 120V not present, check fuse or circuit breaker or repair wiring leading to fireplace.
Spark for six (6) seconds at Ignitor, but no ignition of burner.	a. Check that gas is turned on system purged.	Turn gas on and/or purge system.
	b. Check that tips of ignitor are directly above ports on main burner. Spark is between electrodes and not from one electrode to burner	Position electrodes so tips are directly above burner ports and about 1/4” to 3/8” above burner.
	c. Check for 120V at each coil on the gas valve and listen for click indicating gas valve is opening.	If 120V present, but gas valve does not click, replace gas valve.
Spark for six (6) seconds	Check for clean ground path between electrode bracket and fireplace chassis. Check wiring to wiring diagram label. Check for broken electrode on high-tension lead attachment to module.	Clean, position according to wiring diagram and repair defective electric connections. If all electrical connections are clean and correct, replace module.
Main burner lights normally and then goes out.	a. Check thermostat if applicable.	Turn thermostat up to call for heat or replace.
	b. Check high-tension lead and connector for shorts.	Replace spark electrode assembly.

\*NOTE: Module DS2070S\_A has a five (5) minute lockout timer: If burner does not light wait for five (5) minutes before attempting to relight.

**Attention:** All fireplaces are shipped from the factory equipped for natural gas. Units must be converted for use with propane (LP) gas.

## Fuel Conversion Instructions

**WARNING:** This conversion kit must **ONLY** be applied as part of a conversion kit supplied by the appliance manufacturer for the specific appliance and type of gas being converted.

The conversion shall be carried out in accordance with the requirements of the provincial authorities having jurisdiction and in accordance with the requirements of the CSA B149.2 Installation Code (Canada) and with the requirements of the National Fuel Gas Code Z223.1/NFPA 54 (United States).

**WARNING:** This conversion kit shall be installed by a qualified service agency in accordance with the manufacturer's instructions and all applicable codes and requirements of the authority having jurisdiction. If the information in this instruction is not followed exactly, a fire, explosion or production of carbon monoxide may result causing property damage, personal injury or loss of life. The qualified service agency is responsible for the proper installation of this kit. The installation is not proper and complete until the operation of the converted appliance is checked as specified in the manufacturer's instructions supplied with the kit.

**Installer Notice:** Using an ink pen, fill out the required information on the conversion label. Remove the backing from label and stick label in a visible position on bottom of fireplace close to gas valve.

**Installer Notice:** These instructions must be left with the appliance.

Instructions for converting your fireplace from Natural gas to Propane/LP gas.

All fireplaces are shipped from the factory equipped to operate on Natural gas. To convert the fireplace to operate on Propane/LP gas, follow the instructions below. Please see the appropriate parts list for your model for parts included with the fireplace.

Check the items in the kit with the parts list. Notify the supplier of any items that are missing before installing the conversion kit.

1. Turn off gas supply.
2. Turn off the electrical supply to the appliance if so equipped.

## Replace Burner Orifice

### All Models:

Remove the two (2) screws holding the pilot to the burner bracket.

### 33RDVDSN:

1. Remove the two (2) Phillips head screws from the burner tube retaining bracket. (Fig. 45)
2. With suitable tool, loosen the split nut assembly from the air shutter. (Fig. 46) Lift burner tube up and away.

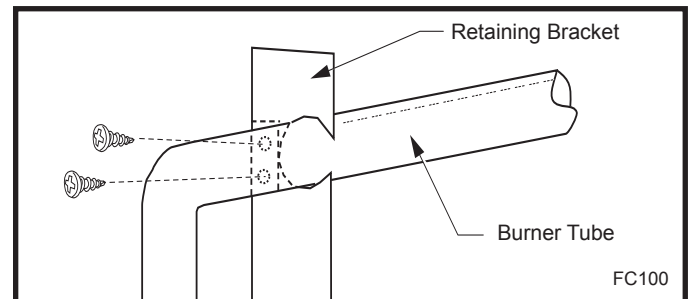

**Fig. 45** Bend retaining bracket away from tube.

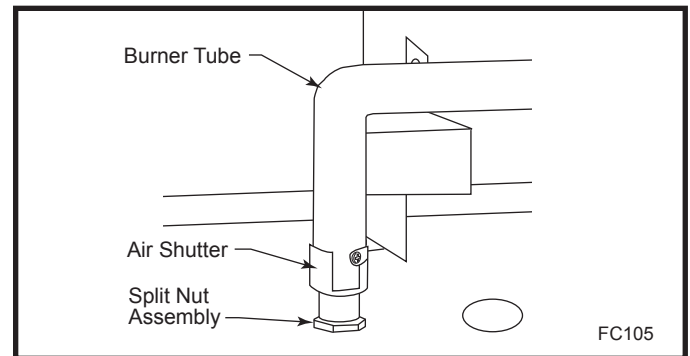

**Fig. 46** Loosen split nut assembly from air shutter and remove burner tube.

### 36/39RDVDSN:

1. Remove lava rock to expose screws and remove grate assembly.
2. Use screwdriver and bend burner tabs outward. (Fig. 47)
3. Loosen the split nut assembly to remove from burner/air shutter. Slide burner tube to the left and off burner orifice. (Fig. 47)

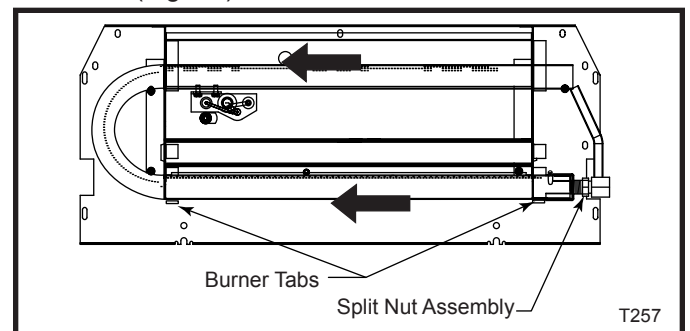

**Fig. 47** Bend tabs down, loosen split nut assembly and slide burner tube to the left.

### All Models:

1. Using a suitable tool replace natural orifice #47 with propane orifice #56 for model 33RDVDSP, or replace natural orifice #45 with propane orifice #55 for model 36RDVDSP, or replace natural orifice #42 with propane orifice #54 for model 39RDVDSP furnished with conversion kit. Tighten orifice with suitable tool until gas tight. (Fig. 48)

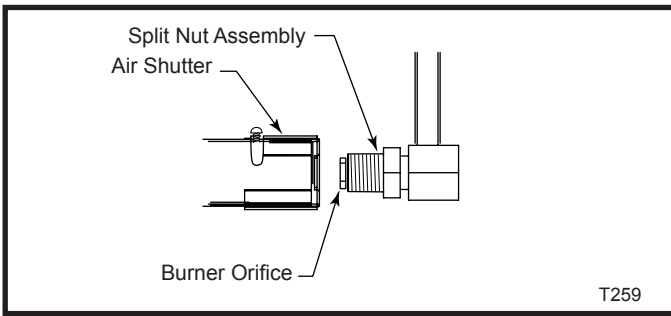

**Fig. 48** Replace burner orifice with correct conversion orifice.

2. Move burner tube back to original position, tighten split nut assembly and bend tabs back up.
3. Set the air shutter opening for propane/LP gas. Tighten air shutter screw. (Refer to Figure 49 and Chart on Page 31)

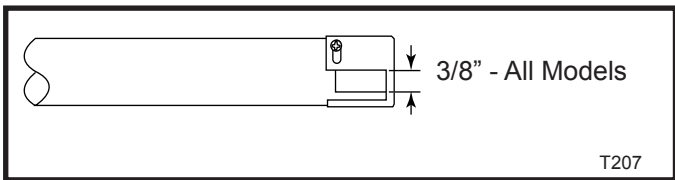

**Fig. 49** Air shutter settings for propane/LP gas.

**NOTE:** Failure to adjust air shutter to proper setting will produce sooting.

4. Fasten pilot to burner bracket with two (2) screws.
5. Replace grate assembly.

**WARNING:** Failure to position the parts in accordance with these diagrams or failure to use only parts specifically approved with this heater may result in property damage or personal injury.

### Valve Conversion

1. Remove plastic cap from regulator fitting. (Fig. 50) Unscrew fitting using a 7/16" wrench. Turn fitting over so end of fitting marked "LPG" (red) screws into valve. Tighten fitting (snug only). Replace plastic cap.
2. Loosen screw and attach a manometer or pressure gauge to the outlet pressure test port (1/8" NPT plugged port) of the control valve.
3. Turn on the gas supply. Turn on the electrical supply to the appliance. Check for gas leaks using soap and water solution or leak detection solution. Bubbles indicate a leak that MUST be corrected. Do not use an open flame to test for gas leaks.
4. Relight the main burners and verify proper burner ignition and operation.

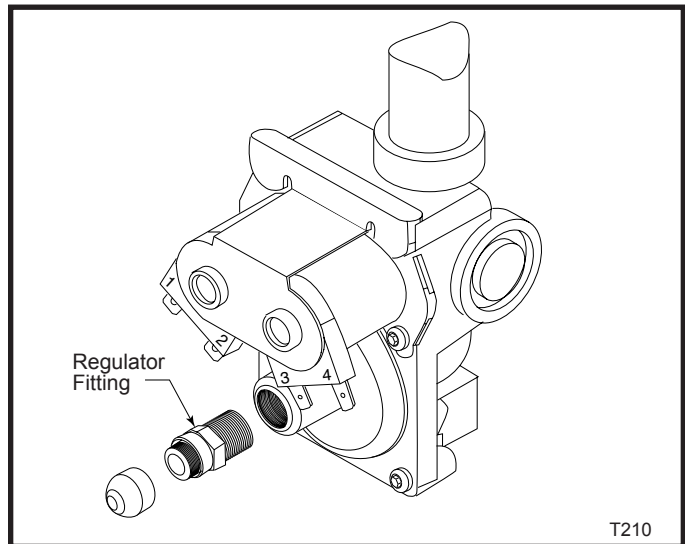

**Fig. 50** White-Rodgers 25M18A-706PI gas control.

5. Check the air shutter opening for the corresponding gas used.
6. With the main burner burning, read the pressure on the manometer or pressure gauge. The pressure on the gauge should read between 9.8" and 10.2" w.c.
7. Turn off the gas supply. Turn off the electrical supply to the appliance.
8. Remove the manometer or pressure gauge. Tighten the screw in the pressure tap.
9. Turn on the gas supply. Turn on the electrical supply to the appliance.
10. Immediately test all gas line connections and the control valve for gas leaks using a soap and water solution or other gas detection solution. Bubbles indicate a leak that MUST be corrected. Do not use an open flame to test for gas leaks.
11. Using a ball point pen, fill out the conversion label that is supplied with the conversion kit. Place the conversion label adjacent to the rating plate.

	Gas Supply Pressure (inches w.c.)		
	Minimum	Normal	Maximum
LP (Propane)	10.8	11.0	14.0
	Manifold Pressure (inches w.c.)		
	Normal		
LP (Propane)	10.0"		

**Max. Input**

33RDVDSP	18,000
36RDVDSP	20,000
39RDVDSP	22,000

Conversion Parts Included with Kit	Kit Number		
	33RDVDSN 20007864	36RDVDSN 20007891	39RDVDSN 20007903
Main Burner Orifice - LP	76776	20007908	20007907
Label, Conversion	10002876	10002876	10002876

## Unit Adjustment

Once installed, the unit should be operated at least three (3) times to ensure that all is in working order.

**NOTE:** Manufacturing oils will smoke during initial firing of appliance. Open windows for ventilation.

Before leaving, the installer should make the following checks:

### Btu Input/Gas Pressure

The fireplace input is marked on the Rating Plate. The gas inlet pressure specified in Table 1 is the pressure where the field-installed gas line connects to the gas control. This is measured at the inlet test port (1/8" NPT plugged port) on the gas valve in the appliance. Ensure that pressure is as shown in Table 1.

The manifold pressure is controlled by a regulator built into the gas control and should be checked at the pressure outlet test port located on the body of the gas valve.

The pressure should be checked with the appliance burning on high (highest setting) **and** all other gas appliances turned on. One must then read the manometer and if pressures are not as specified in Table 1, then the inlet pressure must be adjusted.

The appliance and its individual shut-off valve must be disconnected from the gas supply piping system during any pressure testing of the system at test pressures in excess of 1/2 psig (3.5 KPa).

Pressure ranges are as listed below:

**Table 1**

	Gas Supply Pressure (inches w.c.)		
	Minimum	Normal	Maximum
Natural Gas	4.5"	7.0"	14.0"
LP (Propane)	10.8"	11.0"	14.0"
	Manifold Pressure (inches w.c.)		
	Normal (HI)	Normal (Low)	
Natural Gas	3.5"	1.6"	
LP (Propane)	10.0"	6.3"	

### High Altitude

When installing this fireplace at an elevation between 0 and 2000 feet (0 - 610 m) in the USA and 0 and 4500 feet (0 - 1370 m) in Canada the input rating does not need to be reduced.

When installing this fireplace at an elevation above 2,000 feet (in the United States), it may be necessary to decrease the input rating by changing the existing burner orifice to a smaller size. Input should be reduced four percent (4%) for each 1,000 feet above sea level, unless the heating value of the gas has been reduced, in which case this general rule will not apply. To identify the proper orifice size, check with the local gas utility.

When installing this fireplace at an elevation above 4,500 feet (in Canada), check with local authorities.

Consult your local gas utility for assistance in determining the proper orifice for your location.

### Main Burner

The main burner should be allowed to operate for 15 to 20 minutes before making any adjustment to the burner. The air shutter on the right front of the main burner should be adjusted so that there are no orange/red flames with dark sooty looking tips. A luminous yellow flame with blue base is what is acceptable.

For burner air shutter settings see Air Shutter Settings chart. (Page 31)

If there is too much primary air then the flame will be very blue with yellow tips and smaller flame height.

If there is too little primary air then the flame will be yellow with orange/red tips on the back flames with dark sooty elongated tips. In this condition the glass and logs could show signs of soot accumulation within 10 to 20 minutes.

## Maintenance

### Motor and Blower for Fan Kit (optional)

This motor has been factory oiled and under normal operating conditions should not require oiling.



**WARNING:** Ensure the power is turned off to the fireplace before servicing.

### Cleaning

This unit should be cleaned and serviced by a Qualified Gas Technician at least annually. More frequent cleaning may be necessary if pet hair accumulates, dust and lint are present, or if the unit is located in a high traffic area. A Qualified Agency is defined in the Gas Code.

Cleaning should include burner tubes, orifice/injectors (refer to section B.3 National Fuel Gas Code) and logs. It is recommended that any sediment traps in the gas line be emptied and cleaned at this time. (Refer to Section 3.7.2 National Fuel Gas Code)

### Burner, Firebox and Logs



**CAUTION:** Before cleaning or moving logs or other parts of the unit, be sure to read the section on important safeguards.

Cleaning should be done before the logs are used each year and after long periods of non-use. All cleaning should be carried out when the appliance is cold. Cleaning will be required under normal use. Dusting the front grate or the control knob panel may be required occasionally. Do not use any cleaning fluids to clean the logs or any other part of the appliance.

If the flames show any unusual shapes or behavior, or if the burners fail to ignite properly, then the burner holes may require cleaning. If this occurs, contact your nearest dealer to get the appliance serviced.

Alternatively, the appliance can be cleaned by removing all the logs. Handle the logs gently so as not to damage them. Always lift each log by holding it carefully at each end.

After the logs are removed allowing access to the burner area, use a vacuum cleaner to carefully remove dust and loose particles from the base, logs and from around the burners. Gloves are recommended to prevent the ceramic fibers that compose the logs from pricking your skin. If the skin is pricked, wash gently with soap and water. Use extreme caution in cleaning around the pilot. The spark ignitor should not be moved or altered from the original factory setting. The burner should be placed back into its original locked and secure position after cleaning and servicing (proper location of burners are critical). **NOTE:** All replacements and repairs should be performed by a qualified technician (contact your nearest dealer). After cleaning and/or repairs, follow instructions for positioning of logs as illustrated on Page 23.

### Glass

It will be necessary to clean the glass periodically. During startup it is normal for condensation to form on the glass and cause dirt, lint, etc., to adhere to the inner surface of the glass. There also will be a film deposited on the glass during the initial use of the fireplace due to initial curing of the paint. It is recommended that the glass be cleaned with a non-abrasive household cleaner and warm water. Be sure to rinse and dry the glass well as not to leave any marks. It may be necessary to clean the glass two to three times a season depending on use of the fireplace.

Normal and High Direct Vent Units - Inputs - Orifice Size - Altitude			
Model	BTU/Hr Max. Input	Manifold Pressure @ Max.	Orifice 0 - 2000ft. Altitude in USA Orifice 0-4500ft Altitude in Canada
33RDVDSN	18,000	3.5" w.c.	#47 DMS
33RDVDSP	18,000	10.0" w.c.	#56 DMS
36RDVDSN	20,000	3.5" w.c.	#45 DMS
36RDVDSP	20,000	10.0" w.c.	#55 DMS
39RDVDSN	22,000	3.5" w.c.	#43 DMS
39RDVDSP	22,000	10.0" w.c.	#54 DMS

Conversion Kits		
Model	Change Natural to Propane	Change Propane to Natural
33RDVDSN	20007864*	--
33RDVDSP	--	
36RDVDSN	20007891*	--
36RDVDSP	--	
39RDVDSN	20007903*	--
39RDVDSP	--	

\* Included with fireplace.

Air Shutter Settings	
Model	Opening "A"
33RDVDSN	1/32" (1.0 mm)
33RDVDSP	3/8" (9.5 mm)
36RDVDSN	1/32" (1.0 mm)
36RDVDSP	3/8" (9.5 mm)
39RDVDSN	1/32" (1.0 mm)
39RDVDSP	3/8" (9.5 mm)

**NOTE:** These are minimum settings. Air shutter openings may be increased to prevent flame sooting.

**IMPORTANT:** Always check for gas leaks with a soap and water solution. Do not use open flame for leak testing.

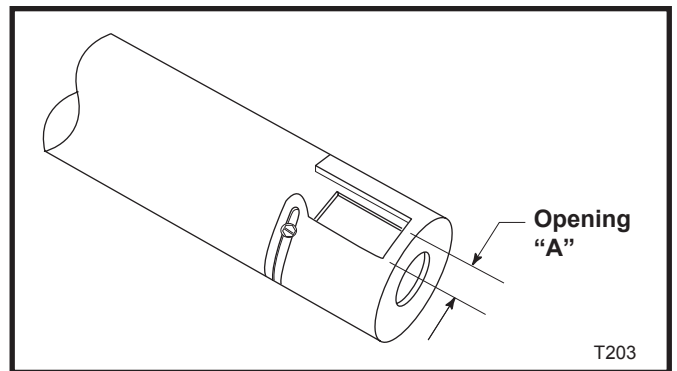
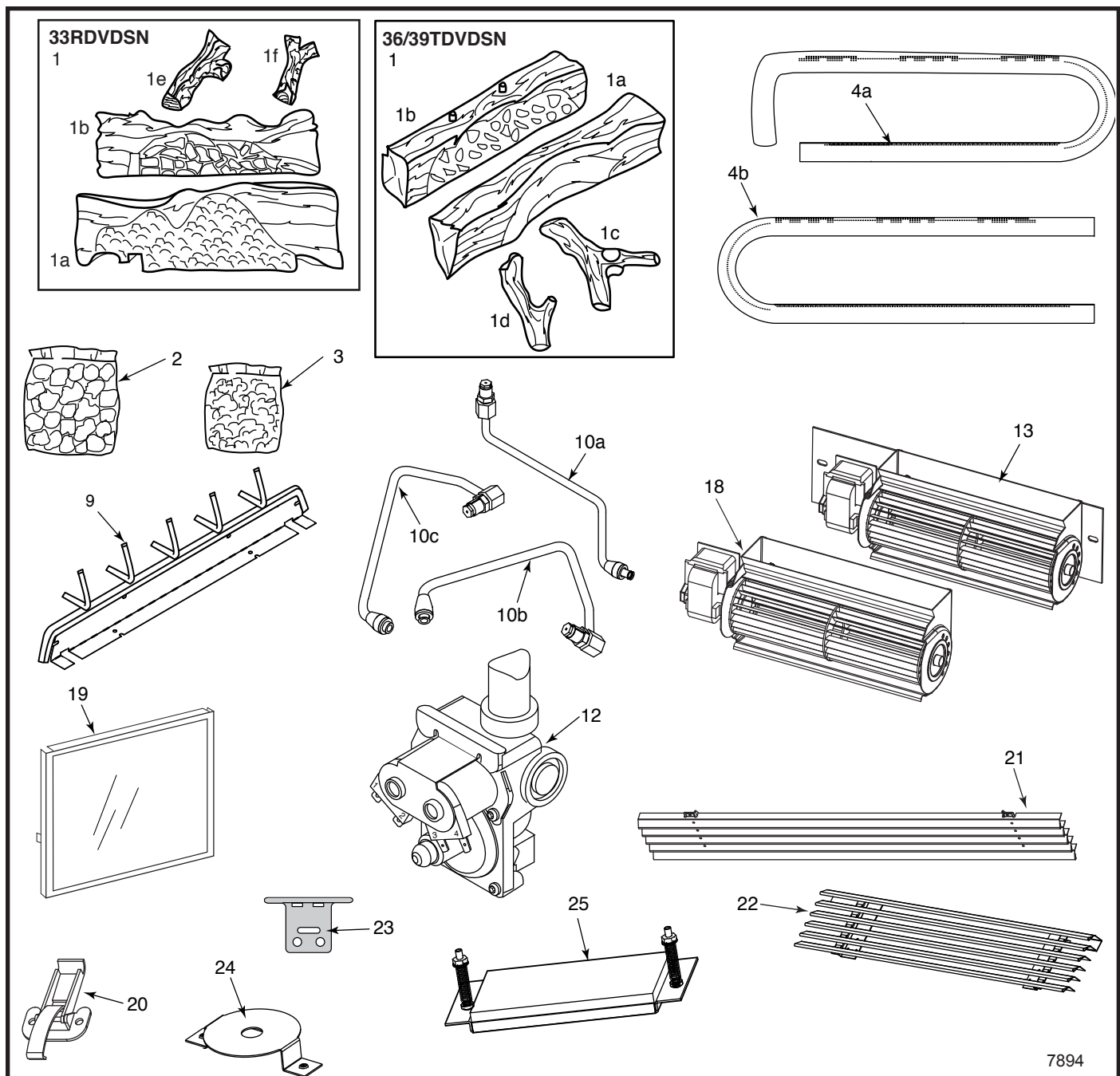

Fig. 51 Air shutter opening.



7894

CFM Corporation reserves the right to make changes in design, materials, specifications, prices and discontinue colors and products at any time, without notice.

## RDVDSN Series Gas Fireplace

Units: GF1HR1, GF1HR2, GF1HR3

Ref.	Description	33RDVDSN	36RDVDSN	39RDVDSN
1.	Log Set (complete)	20007868	20007629	20007629
1a.	Log - Front	20008190	76895	76895
1b.	Log - Back	20008191	20007630	20007630
1c.	Log - Top Right Twig	--	75318	75318
1d.	Log - Top Left Twig	--	75319	75319
1e.	Left Crossover Log	20008192	--	--
1f.	Right Crossover Log	20008193	--	--



**RDVDSN Series Gas Fireplace Heater (continued)**

Ref.	Description	33RDVDSN	36RDVDSN	39RDVDSN
2.	Lava Rock Package (1lb. Bag)	10001454	10001454	10001454
3.	Embers, Platinum	78037	78037	78037
4a.	Burner Tube	20007801	--	--
4b.	Burner Tube	--	20007517	20007517
5.	Orifice, Burner, Nat. (not shown)	20008113	20008112	76775
6.	Orifice, Burner, LP (not shown)	76776	20007908	20007907
7.	DS Ignition Control (Synetek DS2070S)	20007288	20007288	20007288
8.	Spark Electrode w/Wire	72935	72935	72935
9.	Front Grate Assembly	20008048	20008141	20008141
10a.	Manifold Tube (w/Fittings and Orifice)	20008404	--	--
10b.	Manifold Tube (w/Fittings and Orifice)	--	20007585	--
10c.	Manifold Tube (w/Fittings and Orifice)	--	--	20007735
11.	Flexible Gas Line w/On/Off Valve (not shown)	20002500	20002500	20002500
12.	Gas Valve (White-Rodgers)	78581	78581	78581
13.	Fan Assembly (w/Bracket) (FK24 Option)	54103	54103	54103
14.	Electrical Cord (FK24 Option) (not shown)	51865	51865	51865
15.	Fan Temperature Sensor (FK24 Option) (not shown)	51704	51704	51704
16.	Fan Speed Control (FK24 Option) (not shown)	51738	51738	51738
17.	Knob, Fan Speed Control (FK24 Option) (not shown)	51882	51882	51882
18.	Fan Assembly (FK12 Option)	ZA1110	ZA1110	ZA1110
19.	Glass Door Assy	20011627	20011628	20011629
20.	Clamp, Window Frame Assembly	54174	54174	54174
21.	Top Louvre Assembly	10000292	10000037	10000039
22.	Bottom Louvre Assembly	10000293	10000038	10000040
23.	Hinge (Bottom Louvre Assembly)	52356	52356	52356
24.	Relief Plate w/Gasket Assy. Burner Tray	10004192	10004192	10004192

## Optional Accessories

### Fan Kits

#### FK24 Fan Assembly

This auxiliary fan system increases the efficiency of the circulation of the heating air.

The FK24 fan kit allows variable speed control of the circulation fan and also incorporates a heat sensor in the circuit.

#### Specifications

115 Volt / 60Hz / 56 Watts

#### Maintenance

The fan itself does not require regular maintenance, however periodic cleaning of the fan and the surrounding area is required.

Check the area under the control door (lower louvre assembly) and in front of the fan and wipe or vacuum this area at least once a month during the operating season.

#### Installation

The fan assembly and other components are supplied fully wired eliminating the need for a licensed electrician to carry out the installation.

If hard wiring the fan using Method B (following), we strongly recommend the use of a licensed electrician.

1. Open the lower louvre assembly. Maneuver the fan & bracket assembly around the gas valve and lines to locate the unit onto the screw studs on the back of the fireplace.
2. Install the thermal sensor under the bottom of the of the firebox, locating it over the two 10 mm studs and secure it with nuts.
3. Locate the fan speed control unit. This can be fitted behind the lower louvre assembly as in Figure 52 or located remotely in a conveniently located wall mounted electrical box. Remote location of the speed control will require suitable extension of the component wiring.
4. The power supply may be connected in two ways:

##### Method A

Route the 6' lead fitted to the unit to a conveniently located wall socket.

##### Method B (Using EB-1 Receptacle Box)

The EB-1 receptacle box (Pt. # ZA1200) may be hard wired into the house supply. The fan lead is then plugged into the EB-1 box. For instruction on wiring the EB-1 Electrical Junction Box see the earlier chapter in the Installation section of this manual.

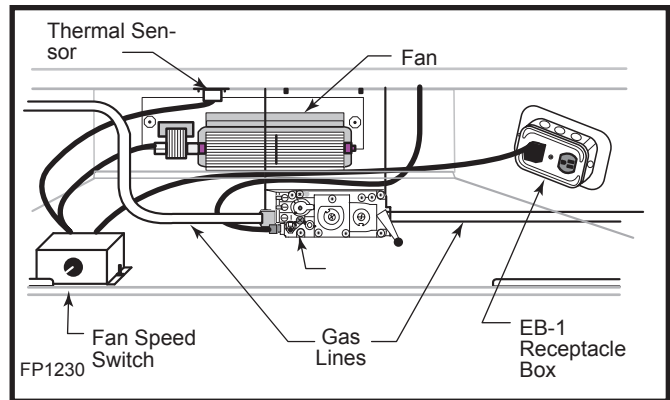

Fig. 52 FK24 fan placement.

#### FK12

This auxiliary fan system increases the efficiency of the circulation of the heating air.

The FK12 Fan Assembly is a fixed speed fan system and does not allow for variable speed control. It does not use the speed control unit or the heat sensor used in the FK24 Kit.

#### Specifications

115 Volts / 60 Hz / 56 Watts.

#### Maintenance

The fan itself does not require regular maintenance, however periodic cleaning of the fan and the surrounding area is required.

Check the area under the control door (lower louvre assembly) and in front of the fan and wipe or vacuum this area at least once a month during the operating season.

#### Installation

The fan assembly is supplied fully wired eliminating the need for a licensed electrician to carry out the installation.

1. Open the lower Louvre assembly. Maneuver the fan & bracket assembly around the gas valve and lines to locate the unit against the back wall of the appliance, resting on the base.
2. With the protective cover removed from the self-adhesive 'Velcro' strips apply mild pressure to the fan & bracket unit to secure the strips to the metal panels. No further securing is required.
3. Power to the fan can be supplied by plugging the supplied lead into a conveniently located wall socket or by using a hard-wired EB-1 connector box.

## Wiring Instructions



The fireplace, when installed, must be electrically connected and grounded in accordance with local codes or, in the absence of local codes, with the current CSA C22.1 Canadian Electric Code.



For USA installations follow the local codes and the national electrical code ANSI/NFPA No. 70.



Should this fan require servicing or repair the power supply must be disconnected. For rewiring of any replacement parts refer to Figure 53.



Any electrical re-wiring of this fan must be done by a licensed electrician.

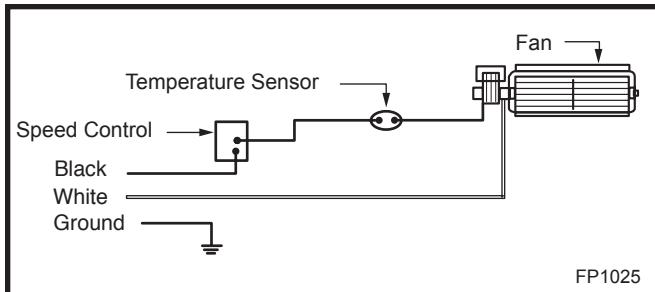

Fig. 53 FK24 fan wiring.

## Ceramic Refractory Kits

Ceramic refractory panels are available in kit form for the RDV/TDV series appliances

Appliance Model	Kit Name
33RDV	AT1CBB
33TDV	AT1CBB
36RDV/TDV	BT2CBB
39RDV/TDV	CT2CBB



Take care when handling the refractory panels as they are fragile until held in place and supported.

**NOTE:** The bottom pieces supplied in ceramic refractory kit are not used on these fireplaces.

**Installation,** refer to Figures 54

1. Remove the front window frame assembly.
2. Remove the logs.
3. Place the lower supports for the side refractory panels on the base of the firebox. Place each support so the slotted hole fits over the forward screw head along the edge of the base.
4. Loosely attach the top adjustable tabs to the studs located in the top of the firebox toward the front corners.

Discard small angular panels.

5. Place the rear refractory panel in place.
6. Slide the side refractory panels into place to hold the rear panel secure. Adjust the top adjustable tabs to hold the side panel against the firebox wall and secure the tab. Repeat the procedure on the other side.
7. Replace the logs and window frame assembly.



For esthetic purposes we recommend lining up the horizontal mortar lines.

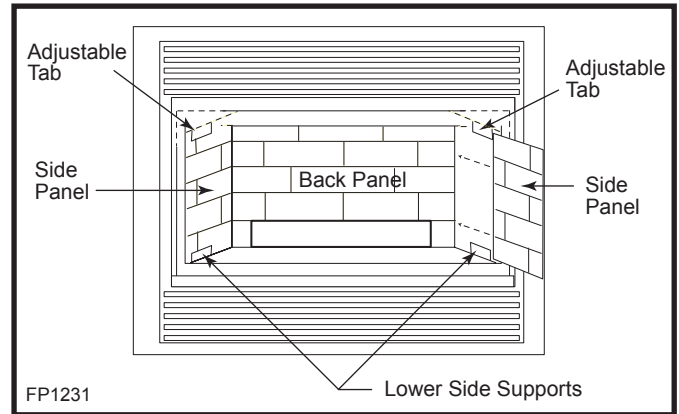

Fig. 54 Ceramic panel installation.

## Decorative Bay Windows

Bay window kits are available for the 33TDVDSN/ 33RDVDSN, 36TDVDSN/36RDVDSN & 39TDVDSN/ 39RDVDSN model appliances.



When fitting the Bay Window Kits the original window frame assembly must remain in place. The Bay Window kit will fit over the existing window frame assembly.

### Installation

1. Remove the existing bottom louvre assembly complete with the hinges.
2. Remove the top louvre assembly.
3. Assemble the Bay Window Kit according to the instructions supplied with the kit.
4. Place the 2 pieces of ceramic refractory along the base of the bay window. (Fig. 55)
5. Hang the Bay Window Assembly over the existing window frame assembly.
6. Re-install the upper louvre assembly.



Do not remove the existing window frame assembly.

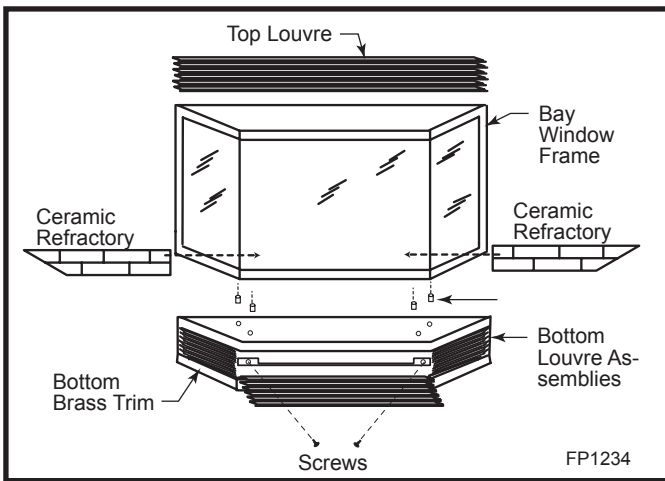

Fig. 55 Bay window installation.

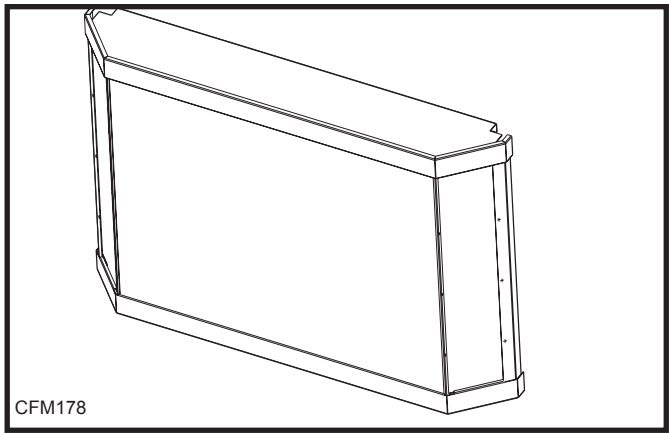

Fig. 56 Bay window screen assembly.

### Bay Window Screen

Bay Window Screen Kits are available for the 33RDVDSN, 36RDVDSN & 39RDVDSN model appliances.



**Do not remove existing window frame assembly! Remove all plastic from brass trims.**

1. Let the fireplace cool down if it has been operating.
2. Remove existing top louvre from fireplace by lifting up and pulling out.
3. Hang Bay Window Screen Frame Assembly over top of existing window frame assembly.

### Remote Controls

Optional remote control units are available to control different functions of the appliances

Model	Function/s Controlled
RC1	ON/OFF
RC2	ON/OFF and Temperature
IMTFK	Wall mounted thermostat control







# One Year Limited Warranty

## TEMCO Fireplace Products Vented Gas Fireplaces

This warranty is limited to **TEMCO Fireplace Products Vented Gas Fireplaces** (henceforth, Product) manufactured by **CFM Corporation** (henceforth, **CFM**).

### Warranty Coverage

**CFM** warrants all components of the Product to be free of defects in materials and workmanship for a period of one year from the date of installation. If, by the sole determination of **CFM**, any component covered under this warranty is found to be defective, **CFM** will, at its option, repair or replace the defective component at no charge and will pay labor cost incurred as specified in the current CFM Labor Allowance Schedule, 71303. If **CFM** determines replacement or repair is not economically practical, **CFM** will, at its option, refund the purchase prices of the Product. Date of installation and purchase price must be verified by acceptable proof of purchase.

This warranty covers only parts and labor as provided above. In no case shall **CFM** be responsible for materials, components or constructions which are not manufactured or supplied by **CFM**, or the labor necessary to install, repair or remove such materials, components or construction.

### Qualification

**The Product must be installed by a qualified installer; strictly in accordance with CFM installation instructions**, and in compliance with local codes and ordinances. The logs must be placed strictly in accordance with the arrangement described in the installation instructions.

The Product must be operated and maintained according to the instructions furnished. **Alteration of the Product in any way is prohibited and voids any and all warranties. Removal of the date plate alters the Product and voids the warranty.**

**The installer must have completed the Installation and Startup Checklist, a copy of which must be sub-**

**mitted along with proof of purchase to obtain prior approval for warranty repair or replacement and to affect a warranty claim. The Checklist is found on Page 19A of this manual.**

The limited warranty applies only to the original owner of the Product or the original owner of the dwelling in which the Product was installed.

Use of any parts other than genuine factory provided replacement parts shall void the warranty.

### Limitations

**CFM** is not responsible for any incidental or consequential damages caused by possible defects in the Product. The duration of any implied warranty with respect to the Product is limited to the duration of the foregoing warranty.

Some states do not allow exclusion of incidental or consequential damages or limits on the duration of implied warranties, so these limitations may not apply to you.

### Warranty Fulfillment

**Claims require specific agreement and consent from CFM Technical Services prior to performing any warranty repair or replacement.**

Please provide the following information when communicating with **CFM** Technical Services, its Dealers or Distributors regarding service under this warranty.

**CFM** reserves the right to investigate any and all claims against this warranty, and to decide on the methods of settlement (if any). This limited warranty is given in lieu of any other expressed or implied warranty, and supersedes all other **CFM** Product warranties.

Model Number: \_\_\_\_\_

Serial Number: \_\_\_\_\_

Date of Installation: \_\_\_\_/\_\_\_\_/\_\_\_\_

Purchased From: \_\_\_\_\_



# TEMCO FIREPLACE PRODUCTS DIRECT VENT FIREPLACES INSTALLATION AND STARTUP CHECKLIST

## Customer Copy

**NOTE: TEMCO Fireplace Products** gas logs and fireplaces require installation by a qualified gas appliance installer. A copy of this checklist must be submitted, along with proof of purchase, when applying to Technical Services for prior written approval of warranty repair or replacement.

- Read and understand installation instructions before attempting installation.

**Verify CORRECT FUEL TYPE**

- Check carton model number.
- Check fireplace label. Models ending in N are for natural gas; those ending in P are for propane (LP gas).

**WARNING: Using the incorrect fuel can create a serious fire hazard and will void the warranties. Install in accordance with local and/or national codes and ordinances. Follow the TEMCO installation instructions.**

- Supply service shutoff valve upstream of gas fireplace.
- Gas line size adequate for input rating (BTU's per hour) of fireplace, per National Fuel Gas Code (NFPA54) in the case of USA installations or Installation Code CAN 1-149 in the case of Canadian installations.

**Make following checks:**

- Gas line integrity at supply line connection.
- Glass front panel position.
- Correct gas pressure. Inlet Pressure \_\_\_\_\_(inches w.c.) Manifold Pressure \_\_\_\_\_(inchesw.c.)
- Piezo ignitor function (millivolt control models only).
- Pilot ignition.
- Main burner ignition.
- Proper flame pattern and color.
- Positioning of logs (in accordance with instructions).
- Clearances to combustibles (vent, framing, mantels, etc.).
- Vent system in compliance with instructions. All joints and connections sealed.
- Wall switch operation. Do not connect millivolt wiring, wall switch or valve to 120v line voltage unless units is specifically DSI equipped.
- Demonstrated proper operating procedure to homeowner.
- Explained the need for proper cleaning and maintenance.
- Check all fittings and connections for gas leaks, correct if necessary.

**Please sign below that checklist has been completed and understood. DATE INSTALLED \_\_\_\_/\_\_\_\_/\_\_\_\_**

Installer	Phone	Consumer	Phone
-----------	-------	----------	-------

## TEMCO FIREPLACE PRODUCTS DIRECT VENT FIREPLACES INSTALLATION AND STARTUP CHECKLIST Installer's Copy

**NOTE: TEMCO Fireplace Products** gas logs and fireplaces require installation by a qualified gas appliance installer. A copy of this checklist must be submitted, along with proof of purchase, when applying to Technical Services for prior written approval of warranty repair or replacement.

- Read and understand installation instructions before installing.

**Verify CORRECT FUEL TYPE**

- Check carton model number.
- Check fireplace label. Models ending in N are for natural gas; those ending in P are for propane (LP gas).

**WARNING: Using the incorrect fuel can create a serious fire hazard and will void the warranties. Install in accordance with local and/or national codes and ordinances. Follow the TEMCO installation instructions.**

- Supply service shutoff valve upstream of gas fireplace.
- Gas line size adequate for input rating (BTU's per hour) of fireplace, per National Fuel Gas Code (NFPA54) in the case of USA installations or Installation Code CAN 1-149 in the case of Canadian installations.

**Make following checks:**

- Gas line integrity at supply line connection.
- Glass front panel position.
- Correct gas pressure. Inlet Pressure \_\_\_\_\_(inches WC) Manifold Pressure \_\_\_\_\_(inchesWC)
- Piezo ignitor function (millivolt control models only).
- Pilot ignition.
- Main burner ignition.
- Proper flame pattern and color.
- Positioning of logs (in accordance with instructions).
- Clearances to combustibles (vent, framing, mantels, etc.).
- Vent system in compliance with instructions. All joints and connections sealed.
- Wall switch operation. Do not connect millivolt wiring, wall switch or valve to 120v line voltage unless units is specifically DSI equipped.
- Demonstrated proper operating procedure to homeowner.
- Explained the need for proper cleaning and maintenance.
- Check all fittings and connections for gas leaks, correct if necessary.

**Please sign below that checklist has been completed and understood. DATE INSTALLED** \_\_\_\_/\_\_\_\_/\_\_\_\_

---

Installer

Phone

Consumer

Phone

### Customer Copy

Model # \_\_\_\_\_ Serial # \_\_\_\_\_

I certify that I have followed all codes and regulations and adhered to the TEMCO Fireplace Products installation instructions. I have completed the proper installation and startup checklist.

#### Installer's Signature

Purchaser \_\_\_\_\_  
Address \_\_\_\_\_  
\_\_\_\_\_  
Phone \_\_\_\_\_  
Retailer \_\_\_\_\_  
Address \_\_\_\_\_  
\_\_\_\_\_  
Phone \_\_\_\_\_  
Date of Purchase \_\_\_\_\_

#### Print Installer's Name

#### WARRANTY REGISTRATION

Please answer the following questions (Check Box):

1. Type of Home  Single Family  Duplex  Apt.  
 Mobile Home  Cabin/Vacation
2. Installed in(Room)  Living  Family  Great  Rec  
 Bedroom  Other
3. Other Choices Considered:  Vented Decorative Gas Log/Fireplace  Woodburning Fireplace  
 Gas Insert  Woodburning Insert  
 Direct-Vent Gas Fireplace/Logs
4. Why did you choose Direct Vent? (Rank in order of importance: 1-6)  
\_\_\_ Appearance \_\_\_ Location Flexibility  
\_\_\_ Builder Decided \_\_\_ Other

-----  
Please cut along dotted line

To register your warranty, please provide the information indicated on this form and mail it to:

**TEMCO Fireplace Products**  
**Attn: Warranty Registration**  
**410 Admiral Blvd.**  
**Mississauga, Ontario Canada L5T 2N6**

Model # \_\_\_\_\_ Serial # \_\_\_\_\_

I certify that I have followed all codes and regulations and adhered to the TEMCO installation instructions. I have completed the proper installation and startup checklist.

#### Installer's Signature

Purchaser \_\_\_\_\_  
Address \_\_\_\_\_  
\_\_\_\_\_  
Phone \_\_\_\_\_  
Retailer \_\_\_\_\_  
Address \_\_\_\_\_  
\_\_\_\_\_  
Phone \_\_\_\_\_  
Date of Purchase \_\_\_\_\_

#### Print Installer's Name

#### WARRANTY REGISTRATION

Please answer the following questions (Check Box):

1. Type of Home  Single Family  Duplex  Apt.  
 Mobile Home  Cabin/Vacation
2. Installed in(Room)  Living  Family  Great  Rec  
 Bedroom  Other
3. Other Choices Considered  Vented Decorative Gas Log/Fireplace  Woodburning Fireplace  
 Gas Insert  Woodburning Insert  
 Direct-Vent Gas Fireplace/Logs
4. Why did you choose Direct Vent? (Rank in order of importance: 1-6)  
\_\_\_ Appearance \_\_\_ Location Flexibility  
\_\_\_ Builder Decided \_\_\_ Other

Canada

# ENERGUIDE

Look for the **EnerGuide**  
Gas Fireplace Energy  
Efficiency Rating in this brochure

*Based on CSA P.4.1-02*

## Efficiency Ratings

Model	EnerGuide Ratings Fireplace Efficiency (%)
33RDVDSN	51
33RDVDSP	51
36RDVDSN	51
36RDVDSP	51
39RDVDSN	59.2
39RDVDSP	59.2

NATIONAL  
FIREPLACE  
INSTITUTE



CERTIFIED  
[www.nficertified.org](http://www.nficertified.org)

We recommend that our gas hearth products be installed and serviced by professionals who are certified in the U.S. by the National Fireplace Institute® (NFI) as NFI Gas Specialists.

## CFM Corporation

2695 Meadowvale Blvd. • Mississauga, Ontario, Canada L5N 8A3  
800-668-5323 • [www.cfmcorp.com](http://www.cfmcorp.com)