

MICRODIN

User's Manual



CE 97

TOTAL
CUSTOMER
SATISFACTION
3 Year Warranty

ISO 9001

Registered Company
Winona, Minnesota USA

Communicating Subpanel Temperature Controller

User Levels:

- New User [go to page 1.1](#)
- Experienced User [go to page 2.1](#)
- Expert User [go to page 2.1](#)

Installers:

- Set-up [go to page 2.1](#)
- Wiring & Installation [go to page 3.1](#)



1241 Bundy Blvd., P.O. Box 5580, Winona, MN USA 55987-5580, Phone: (507) 454-5300, Fax: (507) 452-4507

A

Addendum

MicroDIN User's Manual & Quick Start Guide CE Compliance

Purpose

To meet Mark CE requirements, this addendum provides supplemental information to the MicroDIN User's Manual (W0UD-XUMN Rev A), and the MicroDIN Quick Start Guide (W0UD-XQRN Rev A).

Power Supply Rating

MicroDIN CE Mark compliance requires an IEC 742 rated power supply. This applies to the following power supply references:

User's Manual: p. 3.2, 3.7 (fig. 3.7e), 3.10 (fig. 3.10), 3.11 (fig. 3.11) and A.14

Quick Start Guide: p. 13 (fig. 3.4e), 16, 17 and 22

Figure 3.7e—
Power Wiring

NOTE: An IEC 742 rated power supply is required for CE compliance.

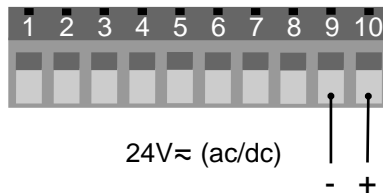

External DC Output Fusing

Also, a customer supplied 1A fuse is required for external dc output connection to meet CE compliance. This applies to the following external dc output references:

User's Manual: p. 3.7 (fig. 3.7b)

Quick Start Guide: p. 13 (fig. 13b)

Figures 3.7b
and 13b—
Control Output,
Open Collector
with External
Power Supply

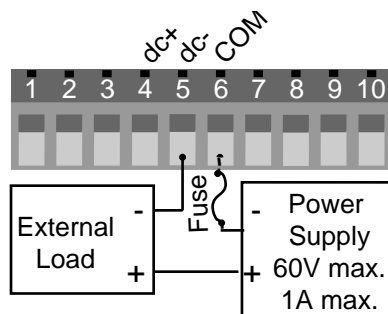

External DC Output Derating

For MicroDIN CE Mark compliance, external load switching (maximum) for an open collector is derated from 60V @ 1A to 42V @ 1A. This applies to the following output rating references:

User's Manual: p. 3.7 (fig. 3.7b) and A.14

Quick Start Guide: p. 13 (fig. 13b) and 22

(1044)

Declaration of Conformity

WATLOW CONTROLS

1241 Bundy Boulevard

Winona, Minnesota 55987 USA

CE 97

Series MicroDIN

Declares that the following product: **English**

Designation: Series MicroDIN
Model Number(s): UD 1 A - 1CES - (Any four numbers or letters)
Classification: Control, Installation Category II, Pollution Degree II
Rated Voltage: 24 to 28V \approx (ac/dc)
Rated Frequency: 50/60 Hz
Rated Power Consumption: 5VA maximum

Meets the essential requirements of the following European Union Directive(s) using the relevant section(s) of the normalized standards and related documents shown:

89/336/EEC Electromagnetic Compatibility Directive

EN 50082-2: 1995 EMC Generic immunity standard, Part 2: Industrial environment

EN 61000-4-2: 1995 Electrostatic discharge

EN 61000-4-4: 1995 Electrical fast transients

ENV 50140: 1994 Radiated immunity

ENV 50141: 1994 Conducted immunity

ENV 50204: 1995 Cellular phone

EN 50081-2: 1994 EMC Generic emission standard, Part 2: Industrial environment

EN 55011: 1991 Limits and methods of measurement of radio disturbance characteristics of industrial, scientific and medical radio-frequency equipment (Class A)

73/23/EEC Low-Voltage Directive

EN 61010-1: 1993 Safety requirements for electrical equipment for measurement, control, and laboratory use, Part 1: General requirements

Déclare que le produit suivant : **Français**

Désignation : Série MicroDIN
Numéro(s) de modèle(s) : UD 1 A - 1CES - (quatre chiffres ou lettres quelconques)
Classification : Commande, installation catégorie II, degré de pollution II
Tension nominale : 24 à 28 V \approx (c.a./c.c.)
Fréquence nominale : 50/60 Hz
Consommation d'alimentation nominale : 5 VA maximum

Conforme aux exigences de la (ou des) directive(s) suivante(s) de l'Union Européenne figurant aux sections correspondantes des normes et documents associés ci-dessous :

89/336/EEC Directive de compatibilité électromagnétique

EN 50082-2 : 1995 Norme générique d'insensibilité électromagnétique, Partie 2 : Environnement industriel

EN 61000-4-2 : 1995 Décharge électrostatique

EN 61000-4-4 : 1995 Courants électriques transitoires rapides

ENV 50140 : 1994 Insensibilité à l'énergie rayonnée

ENV 50141 : 1994 Insensibilité à l'énergie par conduction

ENV 50204 : 1995 Téléphone cellulaire

EN 50081-2 : 1994 Norme générique sur les émissions électromagnétiques, Partie 2 : Environnement industriel

EN 55011 : 1991 Limites et méthodes de mesure des caractéristiques d'interférences du matériel radiofréquence industriel, scientifique et médical (Classe A)

73/23/EEC Directive liée aux basses tensions

EN 61010-1 : 1993 Exigences de sécurité pour le matériel électrique de mesure, de commande et de laboratoire, Partie 1 : Exigences générales

Erklärt, daß das folgende Produkt:

Deutsch

Beschreibung: Serie MicroDIN
Modellnummer(n): UD 1 A - 1 CES - (4 beliebige Zahlen oder Buchstaben)
Klassifikation: Regelsystem, Installationskategorie II, Emissionsgrad II
Nennspannung: 24 bis 28 V \approx (ac/dc)
Nennfrequenz: 50/60 Hz
Nominaler Stromverbrauch: Max. 5 VA

Erfüllt die wichtigsten Normen der folgenden Anweisung(en) der Europäischen Union unter Verwendung des wichtigsten Abschnitts bzw. der wichtigsten Abschnitte der normalisierten Spezifikationen und der untenstehenden einschlägigen Dokumente:

89/336/EEC EWG Elektromagnetische Verträglichkeit

EN 50082-2: 1995 EMC-Rahmennorm für Störsicherheit, Teil 2: Industrielle Umwelt

EN 61000-4-2: 1995 Elektrostatische Entladung

EN 61000-4-4: 1995 Elektrische schnelle Stöße

ENV 50140: 1994 Strahlungsimmunität

ENV 50141: 1994 Leitungsimmunität

ENV 50204: 1995 Mobiltelefon

EN 50081-2: 1994 EMC-Rahmennorm für Emissionen, Teil 2: Industrielle Umwelt

EN 55011: 1991 Beschränkungen und Methoden der Messung von Funkstörungsmerkmalen industrieller, wissenschaftlicher und medizinischer Hochfrequenzgeräte (Klasse A)

72/23/EEC EWG Niederspannungsrichtlinie

EN 61010-1: 1993 Sicherheitsrichtlinien für Elektrogeräte zur Messung, zur Steuerung und im Labor, Teil 1: Allgemeine Richtlinien

Declaro que el producto siguiente:

Español

Designación: Serie MicroDIN
Números de modelo: UD 1 A - 1CES - (Cualquier combinación de cuatro números y letras)
Clasificación: Control, categoría de instalación II, grado de contaminación ambiental II
Tensión nominal: 24 a 28V \approx (Vca/Vcc)
Frecuencia nominal: 50/60 Hz
Consumo nominal de energía: 5 VA máximo

Cumple con los requisitos esenciales de las siguientes directivas de la Unión Europea, usando las secciones pertinentes de las reglas normalizadas y los documentos relacionados que se muestran:

89/336/EEC Directiva de compatibilidad electromagnética

EN 50082-2: 1995 Norma de inmunidad genérica del EMC, parte 2: Ambiente industrial

EN 61000-4-2: 1995 Descarga electrostática

EN 61000-4-4: 1995 Perturbaciones transitorias eléctricas rápidas

ENV 50140: 1994 Inmunidad radiada

ENV 50141: 1994 Inmunidad conducida

ENV 50204: 1995 Teléfono portátil

EN 50081-2: 1994 Norma de emisión genérica del EMC, parte 2: Ambiente industrial

EN 55011: 1991 Límites y métodos de medición de características de perturbaciones de radio correspondientes a equipos de radiofrecuencia industriales, científicos y médicos (Clase A)

73/23/EEC Directiva de baja tensión

EN 61010-1: 1993 Requerimientos de seguridad para equipos eléctricos de medición, control y uso en laboratorios, Parte 1: Requerimientos generales

Erwin D. Lowell

Name of Authorized Representative

Winona, Minnesota, USA

Place of Issue

General Manager

Title of Authorized Representative

February 1, 1997

Date of Issue



Signature of Authorized Representative

Meet the MicroDIN Team



We stand behind our product and are committed to your total satisfaction. Pictured below are some of the people at Watlow who have worked hard to bring you one of the finest industrial temperature controllers available today. Included in the photo are members of the development team, production team, and representatives from our core manufacturing and customer service areas.





Front Row: Rob Hermann, board assembly; Gene Lauer, product manager; Keith Ness, engineering team leader; Steve Lubahn, group leader; Doug Wolfe, technician; Mark Hoven, engineer. **2nd Row,** Sitting behind Front Row: Sally Kotschevar, purchasing; Lisa Voelker, technician; Carolyn Konkel, wave inspection; Mollee Smith, PACE line; John Pham, product development engineer; Randy Haack, application engineer. **Standing:** Barb Lowenhagen; Dave Zill, board assembly; Erin Benson, technician; Kathy Holzworth, production test; John Gabbert, technical documentation; Tonya Adank, surface mount; Stan Breitlow, engineering; Shirley Brown, final assembly; Jason Beyer, application engineer; Rose Johnson, final assembly; Jamil Al-Titi, R & D; Brian Dulek, wave; Jim Brickner, Winona management; Steve Griffiths, manufacturing engineer; Mary White, customer service planner; Dan Johnson, agency coordinator; Les Stellpflug, R & D.

About Watlow Controls

Watlow Controls is a division of Watlow Electric Mfg. Co., St. Louis, Missouri, a manufacturer of industrial electric heating products, since 1922. Watlow begins with a full set of specifications and completes an industrial product that is manufactured totally in-house, in the U.S.A. Watlow products include electric heaters, sensors, controls and switching devices. The Winona operation has been designing solid state electronic control devices since 1962, and has earned the reputation as an excellent supplier to original equipment manufacturers. These OEMs depend upon Watlow Controls to provide compatibly engineered controls which they can incorporate into their products with confidence. Watlow Controls resides in a 100,000 square foot marketing, engineering and manufacturing facility in Winona, Minnesota.

NOTE:
Details of a “Note” appear here in the narrow margin on the outside of each page.

 **CAUTION:**
Details of a “Caution” appear here in the narrow margin on the outside of each page.

 **WARNING:**
Details of a “Warning” appear here in the narrow margin on the outside of each page.

Safety Information

We use note, caution and warning symbols throughout this book to draw your attention to important operational and safety information.

A bold text “NOTE” marks a short message in the margin to alert you to an important detail.

A bold text “CAUTION” safety alert appears with information that is important for protecting your equipment and performance. Be especially careful to read and follow all cautions that apply to your application.

A bold text “WARNING” safety alert appears with information that is important for protecting you, others and equipment from damage. Pay very close attention to all warnings that apply to your application.

The safety alert symbol, , (an exclamation point in a triangle) precedes a general CAUTION or WARNING statement.

The electrical hazard symbol, , (a lightning bolt in a triangle) precedes an electric shock hazard CAUTION or WARNING safety statement.

Technical Assistance

If you encounter a problem with your Watlow controller, see the Troubleshooting Table on [page 6.5](#) first, review all of your configuration information to verify that your selections are consistent with your application: inputs; outputs; alarms; limits; etc. If the problem persists after checking the above, you can get technical assistance from your local Watlow representative, or by dialing (507) 454-5300.

An applications engineer will discuss your application with you.

Please have the following information available when calling:

- Complete model number
- All configuration information
- User’s Manual
- Diagnostic menu readings

Your Feedback

Your comments or suggestions on this manual are welcome, please send them to: Technical Writer, Watlow Controls, 1241 Bundy Blvd., P.O. Box 5580, Winona, MN 55987-5580, Phone: (507) 454-5300, Fax: (507) 452-4507. The MicroDIN User’s Manual is copyrighted by Watlow Winona, Inc., © December 1996, with all rights reserved.

Table of Contents

Chapter 1: Overview	1.1	Indicator Lights	4.14
Introduction to the MicroDIN Controller	1.2	Open Loop Detect	4.14
Setup Steps	1.3	Bumpless Transfer	4.15
Indicator Lights	1.3		
Chapter 2: Communications Setup	2.1	Chapter 5: Parameters	5.1
Communications Overview	2.2	System Group	5.2
EIA-485 Network	2.3	Input Group	5.4
Elements of a MicroDIN 485 Network	2.3	Control Output Group	5.8
PC Connection via 232/485 Converter	2.3	Operation Group	5.11
Special Case 485 Considerations	2.4	PID Group	5.13
Termination Resistor	2.4	Alarm Output Group	5.17
Pull-Up and Pull-Down Resistors	2.4	Error Group	5.22
Modbus™ Protocol	2.5	Characteristics Group	5.25
RTU	2.5	Diagnostics Group	5.27
Access via Registers	2.5	Calibration Group	5.30
MicroDIN Supports	2.5	Chapter 6: Operations	6.1
Modbus™ Register Table	2.6	Startup MicroDIN	6.2
DIP Switches Set Address/Baud Rate	2.7	MicroDIN Shutdown	6.3
MicroDIN DIP Switch Table	2.7	Troubleshooting: Alarms and Errors.....	6.4 - 6.5
Required Parameters Setup	2.8	Calibrating MicroDIN	6.6
Serial Data Format	2.9	Appendix	A.1
Data Format Table	2.9	Modbus™ RTU	A.2
Wiring Tasks	2.9	Glossary	A.8
Wiring Task List	2.9	Declaration of Conformity	A.12
Communications Software	2.9	Specifications	A.14
Watlow's WatLink	2.9	Ordering Information.....	A.15
Other Software Options	2.9	Index	A.16
Chapter 3: Installation Wiring	3.1	Parameter Index	A.18
Introduction	3.2	Required Parameters Setup Order	A.19
Set DIP Lower First.....	3.2	Warranty Information	Back Cover
Mount on DIN Rail or Tabs	3.2		
Wire Unit I/O.....	3.2	Figures by page	
Installation Accessories	3.2	MicroDIN Inputs and Outputs	Figure 1.2
Mount the MicroDIN	3.3	MicroDIN Indicator Lights	1.3
Mount the MicroDIN on a DIN Rail	3.4	MicroDIN Top View with DIP Switches	2.1
MicroDIN RJ-11 and 10-Pin Connectors	3.5	Figure Description	2.1
Input Wiring	3.6	Figure Description	2.1
Output and Power Wiring	3.7	Mounting a MicroDIN Controller	3.2
Communications Wiring	3.8	Mounting on a DIN rail	3.3a
Converter-To-MicroDIN Wiring Example	3.8	Dismounting off a DIN rail	3.3b
Special EIA-485 Considerations	3.9	Bottom view of case with pin assignments	3.4
Wiring Examples	3.10	Control Input, Thermocouple	3.5a
Wiring Examples	3.11	Control Input, 2 and 3-wire RTD	3.5b
		Control Input	3.6a
		Internal Output Circuitry	3.6b
		Alarm Output	3.6c
		Power Wiring	3.6d
		Converter-to-MicroDIN Wiring Example	3.7
		Termination for MicroDIN	3.9
		System Wiring Example	3.10
		System Wiring Example	3.11
		Auto-tuning	4.2
		Power Limits	4.3
		Calibration Offset	4.4
		Filtered and Unfiltered Input Signals	4.5
		Sensor Ranges	4.6
		On/Off Control for Cooling and Heating	4.7
		Proportional Control	4.8
		Proportional plus Integral Control	4.9
		PID Control	4.10
		Alarm Settings	4.11
		Alarm Latching	4.12
		Alarm Silencing	4.13
		Error Information	4.14
		Calibrating diagrams	6.6
Chapter 4: Features	4.1		
The System	4.2		
Auto-tune	4.2		
Power Limit	4.3		
Input	4.4		
Calibration Offset	4.4		
Filter Time Constant	4.5		
Sensor Selection	4.6		
Range Low or Range High	4.6		
Control Methods	4.7		
On/Off	4.7		
Proportional Control	4.8		
Proportional plus Integral (PI) Control	4.9		
Proportional plus Integral plus Derivative (PID) Control	4.10		
Alarms	4.11		
Alarm Set Points	4.11		
Alarm Hysteresis	4.11		
Process or Deviation Alarms	4.12		
Alarm Latching	4.12		
Alarm Silencing	4.13		
Errors	4.14		

Chapter One: Overview

Introduction to the MicroDIN Controller ..	1.2
Setup Steps	1.3
Indicator Lights	1.3

Introduction to the MicroDIN Controller

The Watlow MicroDIN controller is a DIN rail-mounted, temperature controller. It uses one input and two outputs, network connections and dozens of parameters to satisfy a broad variety of control needs.

The single input can use either a thermocouple or RTD sensor. The single control output provides an open collector or switched dc output signal for a power switching device with a DC input. The single alarm output is an electromechanical relay. The network connections allow as many as 32 controllers to be configured and monitored from a single personal computer.

You can configure, operate and monitor the MicroDIN almost entirely from a PLC or personal computer via a serial connection using RJ-11 jacks. Indicator lights on the face of the controller monitor error states, power, communications activity and output activity.

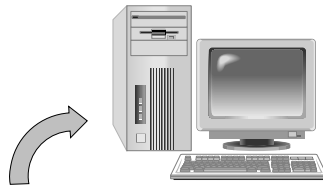

Communications Input and Output to and from Personal Computer



1-32 devices/
EIA-485 Network



Per Unit:

- Sensor Input from the process
- Control Output to the process
- Alarm Output about the process

Figure 1.2 - MicroDIN inputs and outputs in a thermal system

Setup Steps

1. Set up communications.
2. Set the controller's address and baud speed with the DIP switches on the top panel (see [Chapter 2](#), Communications Setup). The controller uses eight data bits with no parity.
3. Mount the controller (see [Chapter 3](#), Wiring).
4. Wire the controller (see [Chapter 3](#), Wiring).
5. Communicate with MicroDIN via an EIA-485 network with Modbus™ RTU protocol.

Indicator Lights

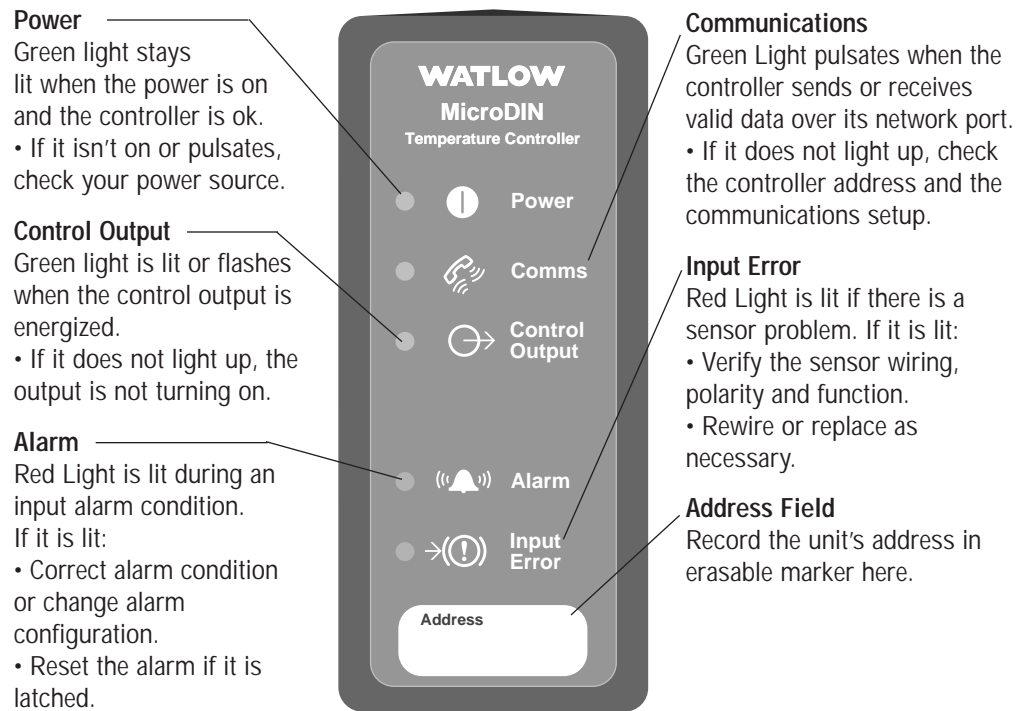

Figure 1.3 - MicroDIN indicator lights

Notes

Chapter Two: Communications Setup

Communications Overview

EIA-485 Network	2.2
Modbus™ Protocol	2.2
Set Address/Baud Rate	2.2
Serial Data Format	2.2
Wiring Tasks	2.2
Communications Software	2.2

EIA-485 Network

Elements of a MicroDIN 485 Network	2.3
PC Connection via 232/485 Converter	2.3
Special Case 485 Considerations	2.4
Termination Resistor	2.4
Pull-Up and Pull-Down Resistors	2.4

Modbus Protocol

RTU	2.5
Access via Registers	2.5
MicroDIN Supports... ..	2.5
Modbus™ Register Table	2.6

DIP Switches Set Address/Baud Rate

MicroDIN DIP Switch Table	2.7
Required Parameters Setup	2.8

Serial Data Format

Data Format Table	2.9
-------------------------	---------------------

Wiring Tasks

Wiring Task List	2.9
------------------------	---------------------

Communications Software

Watlow's WatLink	2.9
Other Software Options	2.9

Communications Overview

EIA-485 Network

The MicroDIN uses the EIA-485 (formerly, RS-485) hardware interface to communicate with three wires in a half-duplex configuration, up to 32 remote devices with a master unit on a network up to 4,000 feet long using 14-26 gauge wire.

Modbus Protocol

The MicroDIN uses Modbus' RTU protocol to read and write to registers that can be viewed or changed from a personal computer. Each MicroDIN parameter has a corresponding Modbus' register and access privileges. The MicroDIN parameter register numbers and the order of priority appear later in this chapter. [Chapter 5](#) details all the MicroDIN parameters, and the Appendix provides information on how to write custom Modbus' applications

Set Address/Baud Rate

You must configure the communications speed and network address of the MicroDIN controller with the eight-bit DIP switch on the top of the unit. Set the controller address with the first six switches and the network speed (9,600 or 19,200 baud) with the eighth switch. Turn to the DIP switch page later in this chapter.

Serial Data Format

The MicroDIN uses the an 8-N-1 data format; 8 data bits, no parity, 1 stop bit, and 1 start bit. See the data format table later in this chapter.

Wiring Tasks

In addition to wiring the controller's input, outputs and power connections, you must also wire the EIA-232-to-EIA-485 converter; connect your computer to the MicroDIN, and connect the MicroDIN communications daisy chain. See Communications Wiring in [Chapter 3](#) for full detail.

Communications Software

Watlow offers a Windows application for MicroDIN, called, WatLink, which will both set up and run multiple MicroDINs over an EIA-485 network using the Modbus' protocol. Turn to a screen sample at the end of this chapter.

You may also write your own application (see Appendix for more detail), or purchase any of several available Modbus'-capable control software packages.

EIA-485 Network

The MicroDIN EIA-485 (RS-485) Network Characteristics

An EIA-485 interface uses three wires in a half-duplex configuration.

The EIA-485 standard specifies a T+/R+ line; a T-/R- line; and a common line. EIA-485 interprets a -5 volt signal <None> as a 1, a +5-volt signal as a 0. Up to 32 remote devices can be connected to a master on a multi-drop network up to 4,000 feet long.

For industrial networks, EIA-485 offers low impedance, a multiple-device capability, strong noise immunity and the long distance capability.

PC Connection via 232/485 Converter

Watlow recommends connecting the MicroDIN to your personal computers with an EIA-232 (RS-232) to EIA-485 (RS-485) converter.

The 232-to-485 converters are proven reliable, low cost, and readily available.

We recommend these suppliers:

- **B & B Electronics Manufacturing Company**

707 Dayton Road, PO Box 1040, Ottawa, IL 61350

Tel: (815) 433-5100; Fax: (815) 434-7094; Web: <http://www.bb-elec.com>

Request part number: **485OIC** with a power supply and the correct 25-pin gender connector for your computer.

- **CMC (Connecticut microComputer, Inc.)**

P.O. Box 186, Brookfield, CT 06804

Tel: (800) 426-2872, (203) 740-9890; Fax: (203) 775-4595

Request part number: **ADA485L** with the correct 25-pin gender connector for your computer.

See [Chapter 3](#) for wiring details.

Special Case 485 Network Considerations

If your EIA-485 network does not work, it may require termination resistors.

Termination Resistor at the Last MicroDIN

 **CAUTION:**
Apply termination and pull-up/pull-down resistors only if necessary to establish data communications. Adding this resistance to a network where it is not required could result in loss of communications and damage to process product.

In some cases long distance networks may require termination resistors. If the continuity checks good and you still cannot get valid responses, add termination.

You can make a terminator by placing a 120 $\frac{1}{2}$ resistor across the C and D terminals of a standard RJ-11 phone plug. Plug the terminator into the open socket in the furthest MicroDIN from the computer.

See [Chapter 3](#), "Installation and Wiring," for a wiring diagram.

Termination and Pull-Up/Pull-Down Resistors at the Converter

If you use a terminator, you should also add pull-up and pull-down resistors to the EIA-485 converter box.

Place a 120-ohm resistor across the transmit/receive terminals (C and D) of the converter box.

Add 1K $\frac{1}{2}$ pull-up and pull-down resistors as shown in [Chapter 3](#) to maintain the correct voltage during the idle state.

See [Chapter 3](#) for wiring diagram.

MicroDIN, A Modbus™ Remote Terminal Unit (RTU)

RTU

The MicroDIN uses Modbus™ RTU (remote terminal unit) protocol to read and write to registers that can be viewed or changed from a personal computer. Sending ASCII text commands to the MicroDIN will not work.

Access Via Registers

Each MicroDIN parameter has a corresponding Modbus™ register and access privileges. The value of each parameter is stored in a Modbus™ register. The access privilege — read only, write only or read/write — determines whether you can change and/or view a parameter's value. [Chapter 5](#) explains some of the interactions between parameters. The tables at the end of this chapter show the parameters and their setup order.

MicroDIN Supports...

Multiple Register Reads

MicroDIN supports Modbus™ Commands 03 and 04 read of a 1- to 32-register block. Responses from -1999 to 9999 are valid data for up to 32 register writes.

Modbus™ 32000 Errors

A Modbus™ read command response of -32000 indicates that a register is not implemented; -32001, register not active; or -32002, not read accessible.

Single Register Writes

MicroDIN supports a Modbus™ write command (06) to a single register.

Multiple Register Writes

MicroDIN supports a Modbus™ write command (16) for multiple writes as long as the data length is 1.

Writing to address 0 broadcasts to all devices on the network.

Write Exceptions

MicroDIN supports write exceptions: 01, illegal function; 02, illegal register; 03, illegal data.

Loop Back

MicroDIN supports a Modbus™ write command 08, “loop back” to echo a message.

⚠ CAUTION:
Avoid writing continuously to EEPROM memory. Continuous writes may result in premature control failure, system downtime and damage to processes and equipment.

See [Disable Non-volatile Memory \(System Group\)](#), Ch. 5.

Compatible Software

You will need compatible software to interact with a MicroDIN controller. One such program is included with the MicroDIN Startup Kit. If you are accustomed to using a Modbus™, see the Appendix for information to help write your own Modbus™ software application.

Modbus Register Numbers

Address			Address		
Absolute	Relative	Parameters	Absolute	Relative	Parameters
40001	0	Model Number (Diagnostics)	40602	601	Input Type (Input)
40002	1	Serial Number (Characteristics)	40603	602	Range Low (Input)
40003	2	Serial Number 2 (Characteristics)	40604	603	Range High (Input)
40004	3	Software ID number (Characteristics)	40605	604	Filter Time Constant (Input)
40005	4	Software Revision (Characteristics)	40606	605	Calibration Offset (Input)
40006	5	Date of Manufacture (Characteristics)	40607	606	Decimal Point (System)
40007	6	Ship Date (Characteristics)	40608	607	Error Clearing Mode (Error)
40017	16	Control Output Hardware (Control Output)	40701	700	Control Output Function (Control Output)
40018	17	Alarm Output Hardware (Alarm)	40714	713	Power Limit Set Point (Control Output)
40025	24	Disable Non-volatile Memory (System)	40715	714	High Side Power (Control Output)
40101	100	Input Actual (Input)	40716	715	Low Side Power (Control Output)
40102	101	Input Error (Input)	40718	717	Alarm Output Function (Alarm Output)
40104	103	Output Power (Control Output)	40720	719	Alarm Type (Alarm Output)
40107	106	Alarm Condition (Alarm Output)	40721	720	Alarm Hysteresis (Alarm Output)
40201	200	Operation Mode (Operation)	40722	721	Alarm Latching Mode (Alarm Output)
40205	204	PID Output Power (PID)	40723	722	Alarm Silencing Mode (Alarm Output)
40206	205	Proportional Term (PID)	40724	723	Alarm Active Sides (Alarm Output)
40207	206	Integral Term (PID)	40725	724	Alarm Logic (Alarm Output)
40208	207	Derivative Term (PID)	40901	900	Units Type (System)
40210	209	System Error (Error)	40902	901	C or F (System)
40211	210	Open Loop Error (Error)	40903	902	Input Error Action (Input)
40301	300	Set Point (Operation)	40904	903	Fixed Manual Output (Control Output)
40302	301	User Operation Mode (Operation)	40905	904	Activate Open Loop Detect (Error)
40305	304	Auto-tune Set Point (PID)	41501	1500	Ambient (CJC) Temperature (System)
40306	305	Initiate Auto-tune (PID)	41502	1501	Ambient (CJC) A-to-D Counts (Diagnostics)
40311	310	Manual Output Power (Operation)	41503	1502	RTD Lead Compens. A-to-D Counts (Diag)
40312	311	Clear Error (Error)	41504	1503	RTD Lead Resistance (Diagnostics)
40322	321	Alarm Low (Alarm Output)	41505	1504	Input A-to-D Counts (Diagnostics)
40323	322	Alarm High (Alarm Output)	41513	1512	Enter Diagnostics Mode (Diagnostics)
40332	331	Clear Alarm (Alarm Output)	41514	1513	Test Displays (Diagnostics)
40333	332	Silence Alarm (Alarm Output)	41515	1514	Test Outputs (Diagnostics)
40501	500	Proportional Band (PID)	41601	1600	Enter Calibration Mode (Calibration)
40502	501	Integral (PID)	41602	1601	Restore to Factory Calibration (Calibration)
40503	502	Reset (PID)	41603	1602	Reset Factory Defaults (Calibration)
40504	503	Derivative (PID)	41604	1603	Calibration Commands (Calibration)
40505	504	Rate (PID)			
40507	506	Cycle Time (PID)			
40508	507	Control Output Hysteresis (PID)			
40601	600	Sensor Type (Input)			

Set Address/Baud Rate

Configure the communications speed and network address of the MicroDIN controller with the eight-bit DIP switch on the top panel. Set the controller address with the first six switches. Set an address between 1 and 63. The network will not work correctly if any two controllers have the same address. DIP switch 1 sets the left-most binary digit. Switch 6 sets the right-most digit.

Record the MicroDIN's address in erasable marker on the white space on the front of the unit.

The seventh switch has no effect.

Set the network speed (9,600 or 19,200 baud) with the eighth switch.

Figure 2.7 - MicroDIN top view with DIP switches and baud settings

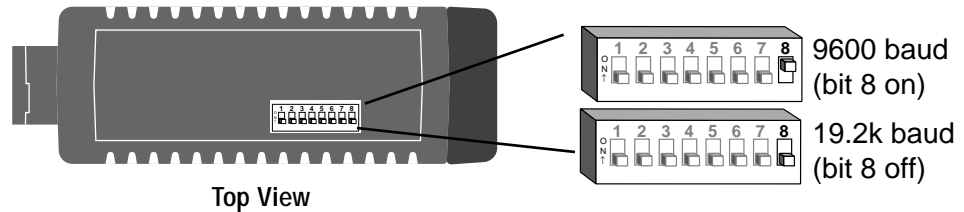

Table 2.7 - Decimal-to-binary conversion

Dec.	Binary	Dec.	Binary	Dec.	Binary	Dec.	Binary
1	000001	16	010000	32	100000	48	110000
2	000010	17	010001	33	100001	49	110001
3	000011	18	010010	34	100010	50	110010
4	000100	19	010011	35	100011	51	110011
5	000101	20	010100	36	100100	52	110100
6	000110	21	010101	37	100101	53	110101
7	000111	22	010110	38	100110	54	110110
8	001000	23	010111	39	100111	55	110111
9	001001	24	011000	40	101000	56	111000
10	001010	25	011001	41	101001	57	111001
11	001011	26	011010	42	101010	58	111010
12	001100	27	011011	43	101011	59	111011
13	001101	28	011100	44	101100	60	111100
14	001110	29	011101	45	101101	61	111101
15	001111	30	011110	46	101110	62	111110
		31	011111	47	101111	63	111111

Note: This table also appears inside the back cover, [p. A.19](#)

Required Parameters Setup Order

This table provides 1) the correct order of entry, 2) the effect of a parameter change, and 3) a place to document settings.

Changing this →
Affects this ↓

CAUTION:
Parameters should be set up in this order.

Key:
D = Changing will change the default
C = Changing will convert the temperature scale
O = Other effect (see [Ch. 5](#))
(See Parameter Index, [p. A.18](#), for detail)

Document your settings below

Communication Setup

	Units Type	C or F	Control Output Function	Sensor Type	Input Type	Range Low	Range High	High Side Power	Low Side Power	Alarm Type	Operation Mode	Decimal
Units Type												
C or F												
Input Error Action												
Control Output Function												
Set Fixed Manual Output		O										
Open Loop Detect												
Sensor Type												
Input Type				O								
Range Low		C	D	D							C	
Range High		C	D	D							C	
Decimal Point			D	D								
Calibration Offset		C	D	D							C	
Filter Time Constant			D	D								
Error Clearing Mode												
Power Limit Set Point		C	D	D							C	
High Side Power		O										
Low Side Power		O										
Alarm Output Function												
Alarm Type			D	D								
Alarm Hysteresis		C	D	D							C	
Alarm Latching Mode												
Alarm Silencing Mode												
Alarm Active Sides												
Alarm Logic												
Alarm High		C	D	D				O			C	
Alarm Low		C	D	D				O			C	
Propband		C	D	D							C	
Integral	O											
Reset	O											
Derivative												
Rate												
Cycle Time												
Output Hysteresis		C	D	D							C	
Operation Mode												
Set Point												
Manual Output Power			O				O	O		O		
Set Point		C	D	D	O	O					C	

Table 2.8 - Parameters Setup order.

Serial Data Format

Configure your computer's COM1 or COM2 (communications) port data format to match the MicroDIN's settings in the table below.

Table 2.9a -
Serial Data Format

Data Bits	Parity	Stop Bit	Start Bit
8	None	1	1

MicroDIN Installation Wiring Tasks

MicroDIN requires these wiring tasks for a successful installation

1. Wire MicroDIN sensor input.
2. Wire MicroDIN Output 1, the control output.
3. Wire MicroDIN Output 2, the alarm output.
4. Wire MicroDIN power.
5. Connect the MicroDIN communications daisy chain.
6. Wire the 232-to-485 converter; connect to the computer.
7. If necessary, wire the termination and pull-up/pull-down resistors.

Communications Software

WatLink

Figure 2.9b -
WatLink for MicroDIN
sample software screen

Watlow offers a Modbus™ package in WatLink, software that will set up and run multiple MicroDINs over an EIA-485 network. WatLink, a Windows 3.31 or Windows 95 application, is available from any Watlow sales representative or authorized distributor. WatLink can handle up to 32 different MicroDIN units.

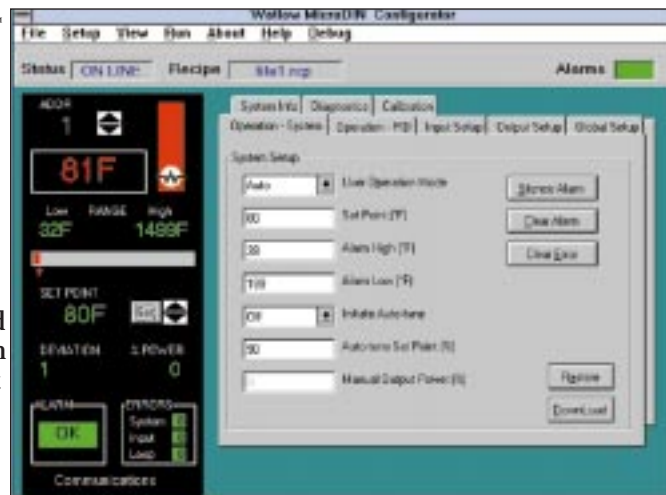

Other Software

To communicate with MicroDIN, you must use a Modbus™ RTU (remote terminal unit) compatible software package. Sending ASCII commands via a standard serial communication application will not work. Refer to the Appendix if you're writing your own Modbus™ RTU application.



Notes

3

Chapter Three: Installation and Wiring

Introduction	
Set DIPs First	3.2
Mount on DIN Rail Tabs.....	3.2
Wire Unit I/O	3.2
Installation Accessories	3.2
Mounting the MicroDIN	3.3
Mounting the MicroDIN on a DIN Rail ...	3.4
MicroDIN RJ-11 and 10-pin Connectors	3.5
Input Wiring	3.6
Output and Power Wiring	3.7
Communications Wiring	3.8
Converter-To-MicroDIN Wiring Example	3.8
Special EIA-485 Considerations	3.9
Wiring Example	3.10
Wiring Example	3.11

Introduction

For a successful MicroDIN installation you need to cover the tasks cited in the subheads below. If you do all these things and the MicroDIN doesn't work, go to the troubleshooting chart in [Chapter 6](#).

Set DIP Switch First

If you haven't done it already, set the controller's address and baud speed with the DIP switches on the top of the unit (see [Chapter 2](#), Communications Setup). The controller uses eight data bits with no parity, and 1 stop bit.

Mount on DIN Rail or Tabs

Mount the controller(s) either on an EN 50022 35mm x 7.5mm DIN rail or with the built-in mounting tabs.

Wire Unit I/O

Wire the MicroDIN's input, output, communications and power connections using the diagrams in this chapter.

Installation Accessories

0219-0218-0000 Included, 6-inch communications cable (RJ-11, 4-conductor, straight through)

0836-0445-0000 Included, 10-pin removable connector with screw terminals

Not Included:

0219-0217-0000 7-foot communications cable (RJ-11, 4-conductor, straight through)

0830-0473-0000 Communications converter (EIA-232 to EIA-485)

0830-0474-0000 Power supply (120V~ (ac) input, 24V= (dc) output)

Mounting the MicroDIN

To mount a MicroDIN on a DIN rail, hook the upper lip of the rail mounting bracket onto the rail and press the controller down until the bottom lip of the mount snaps onto the rail. To remove, as you push the back of the controller down lift the front up until the bottom lip unsnaps from the rail.

To mount a MicroDIN on a panel, use the dimensions below to drill screw holes for the mounting bracket.

Figure 3.3 - Mounting a MicroDIN controller.

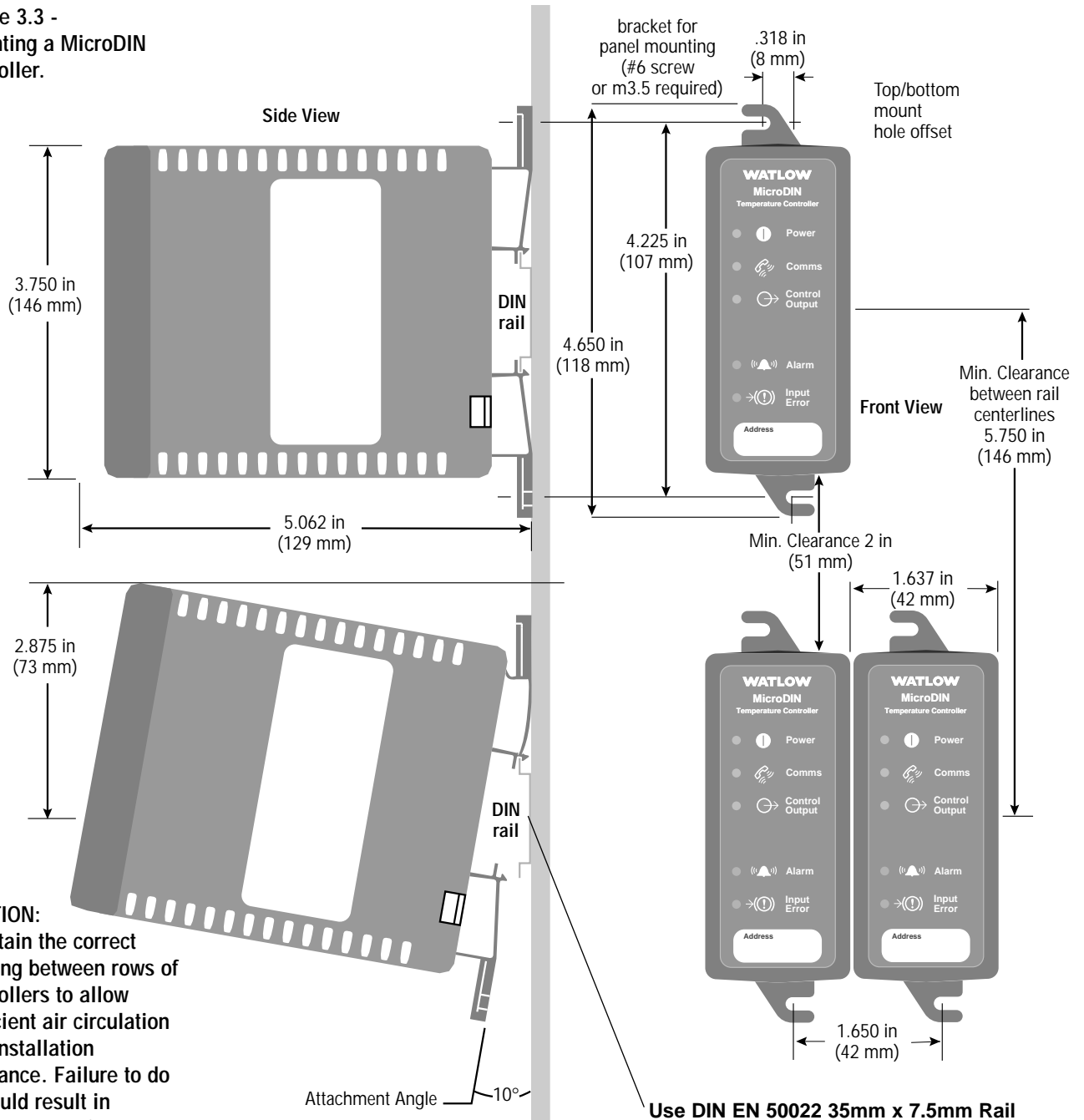

CAUTION: Maintain the correct spacing between rows of controllers to allow sufficient air circulation and installation clearance. Failure to do so could result in damage to equipment.

Mounting the MicroDIN on a DIN rail

To Mount MicroDIN

1. Push unit in and down to catch rail hook on top of rail.
2. Rotate bottom of unit in toward rail.
3. Rail clasp will audibly “snap” into place. If the MicroDIN does not snap into place, check to see if the rail is bent.

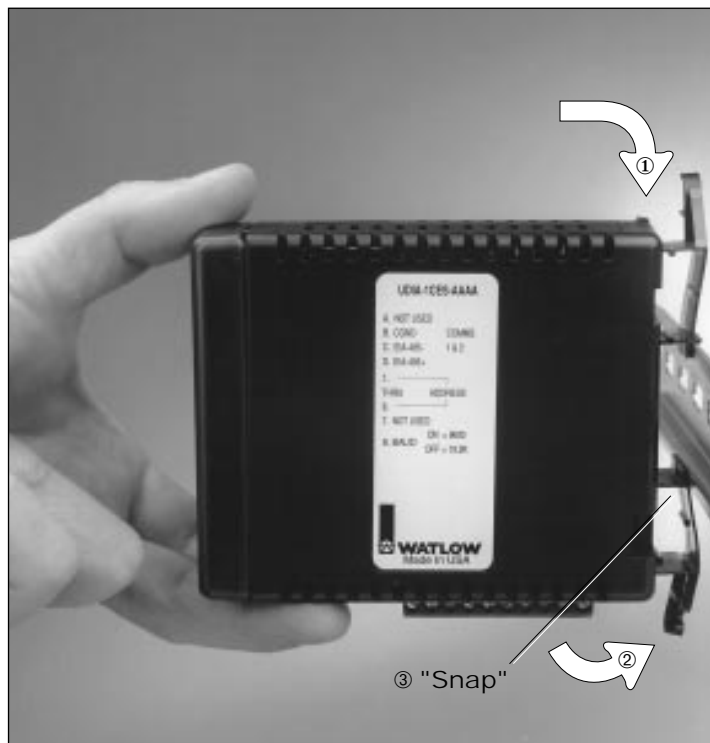

Figure 3.4a -
Mounting a MicroDIN
controller on a DIN rail.

To Dismount MicroDIN

1. Press down on back of controller until the bottom hook clears the rail.
2. Then rotate bottom up and away from rail.

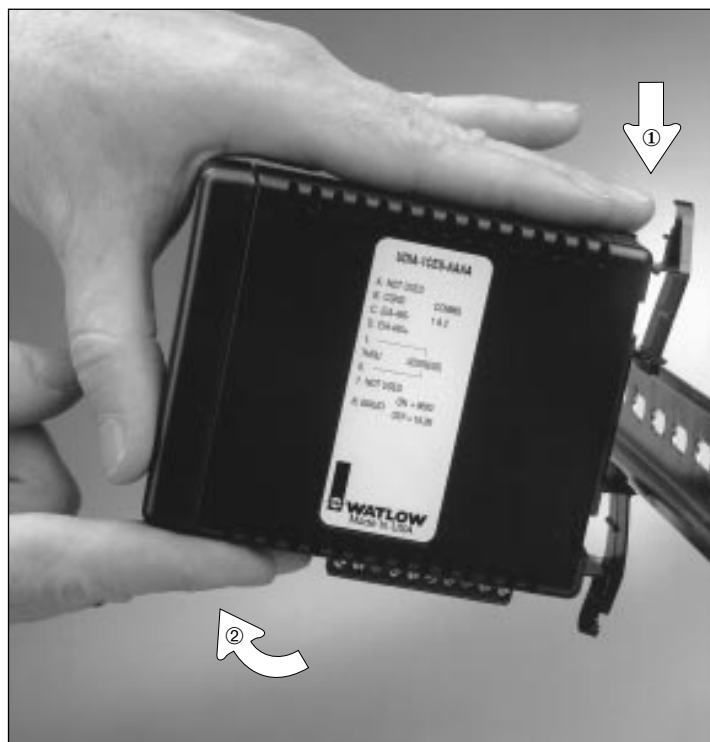

Figure 3.4 b-
Dismounting a MicroDIN
controller from a DIN rail.

MicroDIN RJ-11 and 10-pin Connectors



WARNING:

To avoid potential electric shock, use National Electric Code (NEC) safety practices when wiring and connecting this unit to a power source and to electrical sensors or peripheral devices. Failure to do so could result in injury or death.

The MicroDIN 10-pin screw terminal connector, on the bottom of the case, links it to its power supply, control input, control output and alarm output. Use 26- to 14-gauge wire to connect to the plug terminals.

The alarm output is an electromechanical relay.

See the Appendix for information on sensor ranges and specifications. See [Chapter 5: Parameters](#) for information about software configuration.

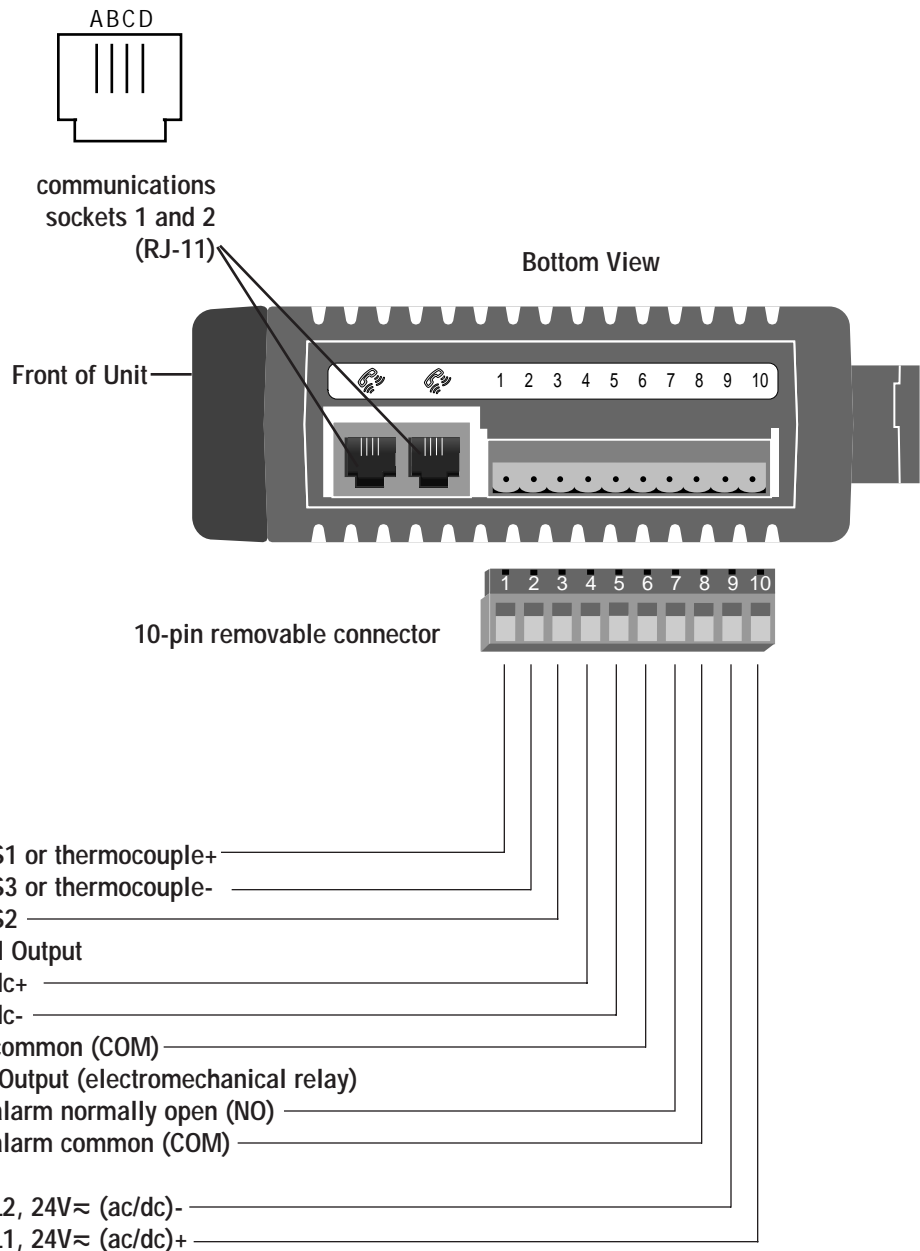

Figure 3.5 - Bottom view of MicroDIN case with connector assignments.



WARNING:

Install high or low temperature limit control protection in systems where an over temperature fault condition could present a fire hazard or other hazard. Failure to install temperature limit control protection where a potential hazard exists could result in damage to equipment and property and injury to personnel.

Input Wiring

Install and Wire

Figure 3.6a — MicroDIN Isolation Diagram

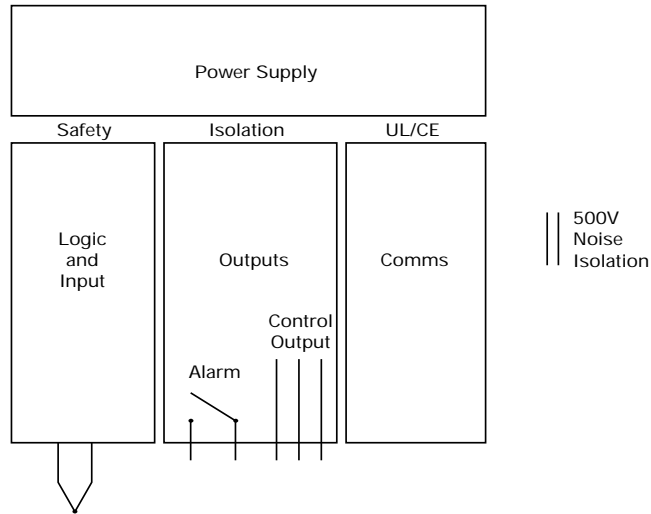

Figure 3.6b — Control Input, Thermocouple

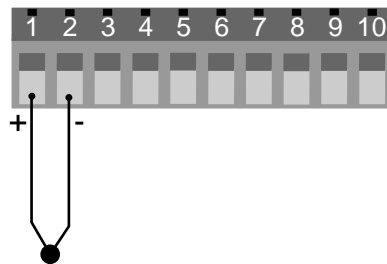

Figure 3.6c — Control Input, 2-wire RTD

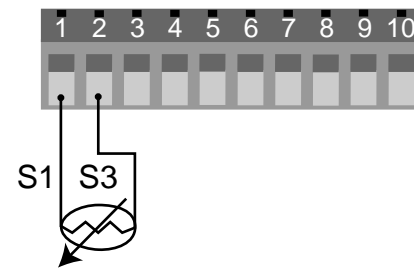
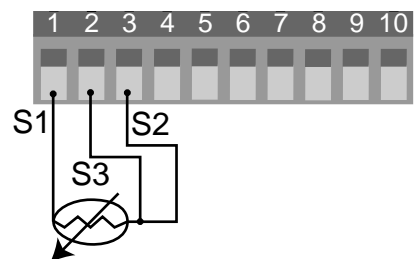
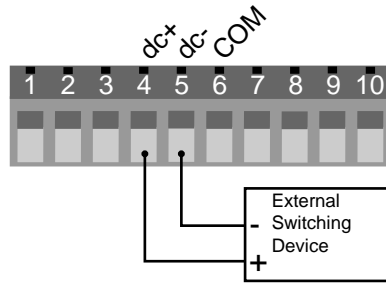

Figure 3.6d — Control Input, 3-wire RTD



Output and Power Wiring

Figure 3.7a —
Control Output, Switched DC
with Internal Power Supply



NOTE:
The current limit feature
is disabled in this version
of the controller.

Figure 3.7b —
Control Output, Open Collector
with External Power Supply

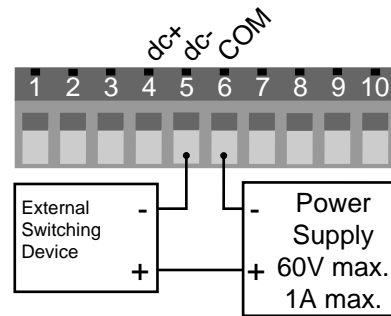
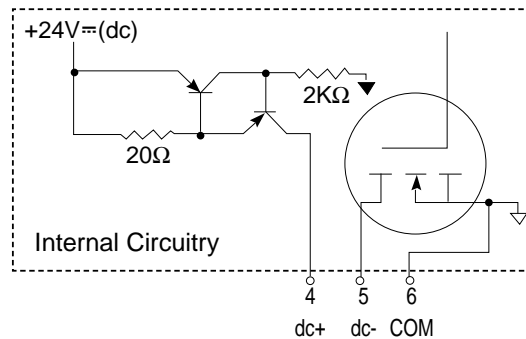
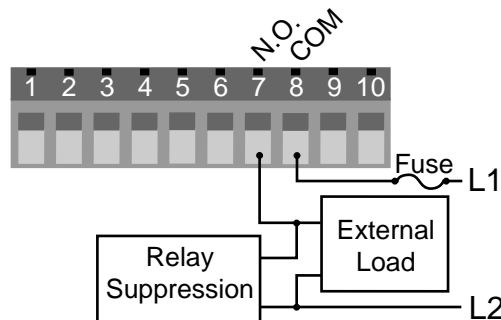

Figure 3.7c — Internal Output Circuitry



⚠
WARNING:
To avoid potential
electric shock, use
National Electric Code
(NEC) safety practices
when wiring and
connecting this unit to a
power source and to
electrical sensors or
peripheral devices.
Failure to do so could
result in injury or death.

Figure 3.7d — Alarm Output



NOTE:
Relay suppression
required only for
inductive loads.

Figure 3.7e — Power Wiring

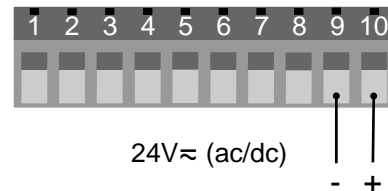

Communications Wiring

Figure 3.8a - MicroDIN communications daisy chain via RJ-11 connectors.

NOTE:
If your network doesn't function, see [Chapter 2](#) for special EIA-485 considerations.

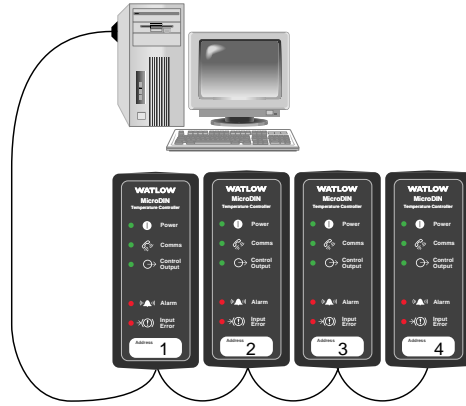

Install and Wire

Converter-To-MicroDIN Wiring Example

Figure 3.8b- B&B Converter to MicroDIN Wiring
(B&B Electronics Manufacturing Company, Ph. 815-433-5100)

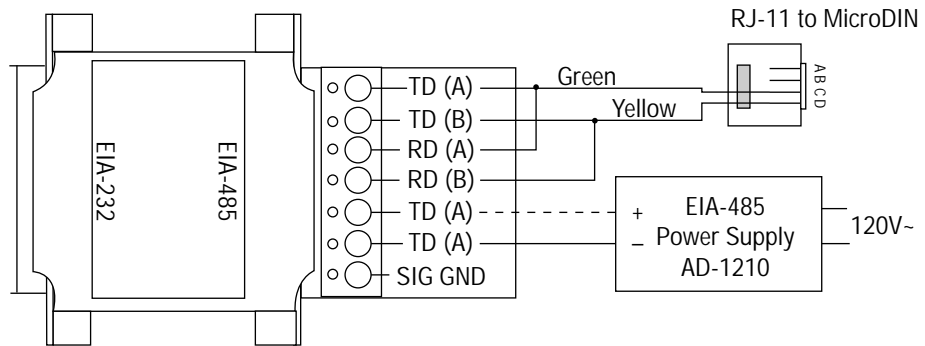

WARNING:
To avoid potential electric shock, use National Electric Code (NEC) safety practices when wiring and connecting this unit to a power source and to electrical sensors or peripheral devices. Failure to do so could result in injury or death.

Figure 3.8c - CMC Converter to MicroDIN Wiring
(CMC Connecticut Micro-Computer, Inc. Ph. 800-426-2872)

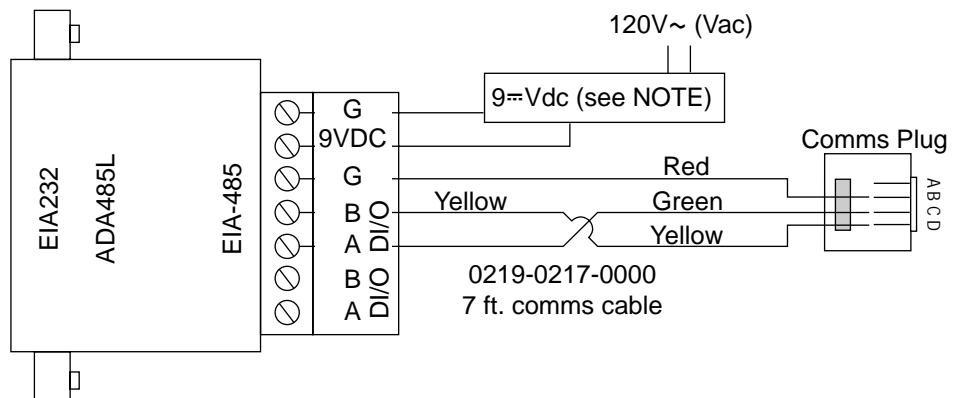

NOTE:
The CMC converter requires an external power supply when used with a laptop.

Special EIA-485 Network Considerations

If your MicroDIN network needs termination and pull-up and pull-down resistors, wire them per the diagrams below. See [Chapter 2](#), “Communications Setup.”

Figure 3.9 a- Termination for MicroDIN; RJ-11 phone plug with 120Ω resistor across C and D

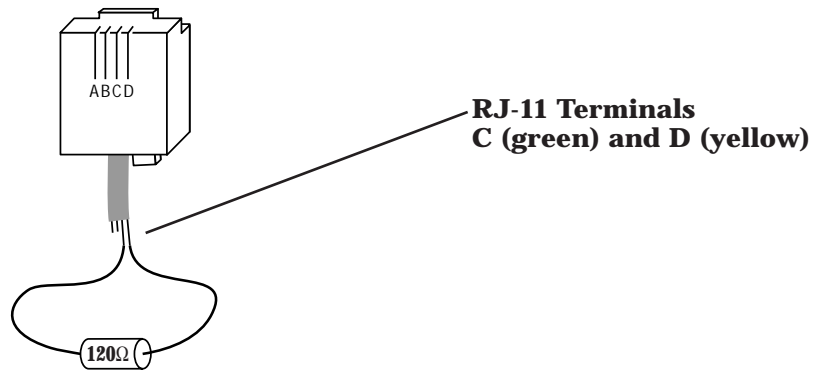

Plug terminator into open socket in MicroDIN controller furthest from computer, the last unit on the network.

Figure 3.9b - Termination for EIA-232/EIA-485 Converter with pull-up and pull-down resistors.

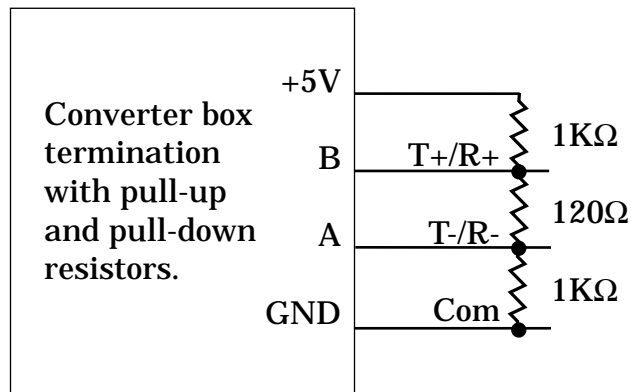

Wiring Examples



WARNING:
To avoid potential electric shock, use National Electric Code (NEC) safety practices when wiring and connecting this unit to a power source and to electrical sensors or peripheral devices. Failure to do so could result in injury or death.

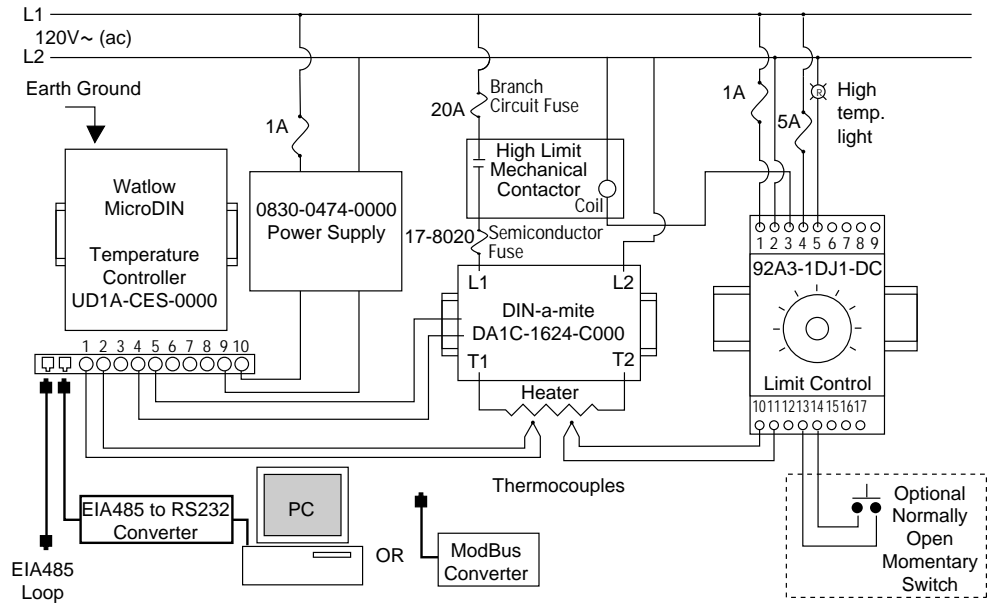

Figure 3.10 - System wiring example, schematic.



WARNING:
Install high or low temperature limit control protection in systems where an over temperature fault condition could present a fire hazard or other hazard. Failure to install temperature limit control protection where a potential hazard exists could result in damage to equipment and property and injury to personnel.



WARNING:
To avoid potential electric shock, use National Electric Code (NEC) safety practices when wiring and connecting this unit to a power source and to electrical sensors or peripheral devices. Failure to do so could result in injury or death.

Figure 3.11 - System wiring example, ladder diagram.



WARNING:
Install high or low temperature limit control protection in systems where an over temperature fault condition could present a fire hazard or other hazard. Failure to install temperature limit control protection where a potential hazard exists could result in damage to equipment and property and injury to personnel.

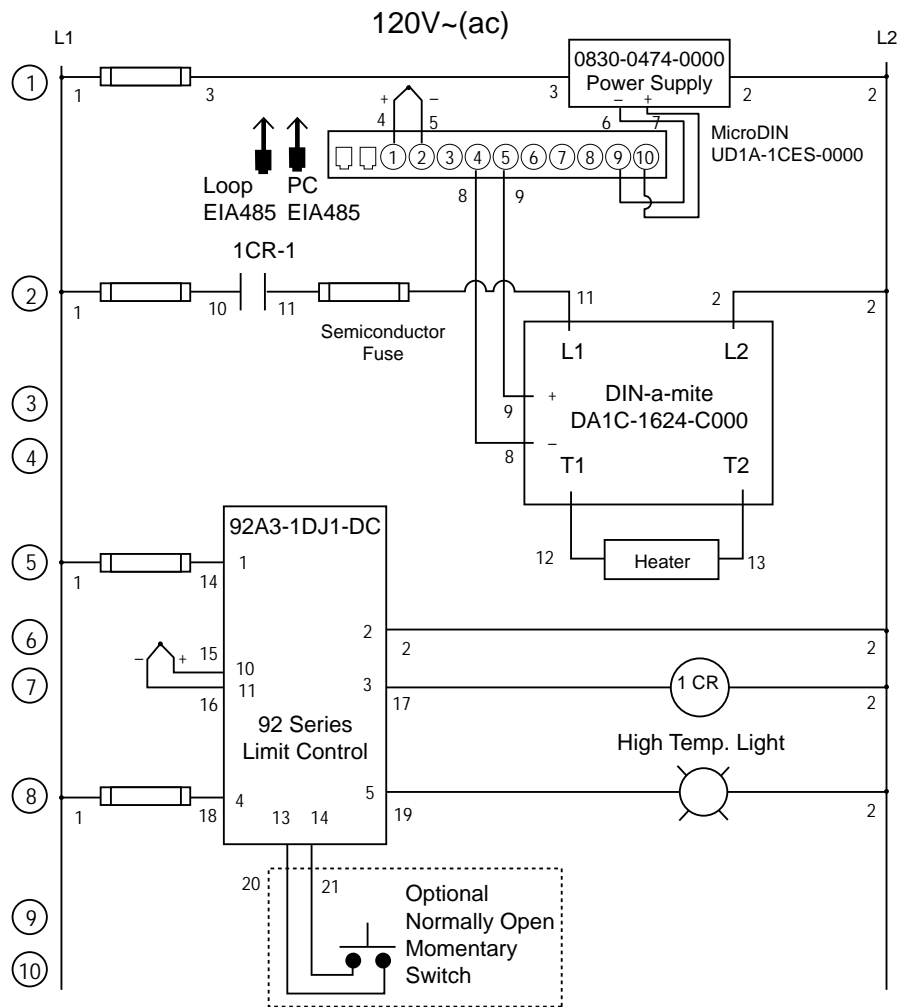



Notes

Chapter Four: Features

The System	
Auto-tune	4.2
Power Limit	4.3
Input	
Calibration Offset	4.4
Filter Time Constant	4.5
Sensor Selection	4.6
Range Low and Range High	4.6
Control Methods	
On/Off	4.7
Proportioned Control	4.8
Proportioned plus Integral (PI) Control	4.9
Proportioned plus Integral plus Derivative (PID) Control	4.10
Alarms	
Alarm Set Points	4.11
Alarm Hysteresis	4.11
Process or Deviation Alarms	4.12
Alarm Latching	4.12
Alarm Silencing	4.13
Errors	
Indicator Lights	4.14
Open Loop Detect	4.14
Bumpless Transfer	4.15

The System

Auto-tune

Auto-tuning allows the controller to explore the responsiveness of the system in order to determine an effective set of parameters for PID control. To do this it crosses an auto-tune set point five times, then controls at the normal set point using the new parameters.

Use Auto-tune Set Point (PID Group) to select the temporary set point, as a percentage of the normal set point, that the controller will tune to. Initiate or cancel the auto-tune process with Auto-tune (PID Group). The default value is 90%.

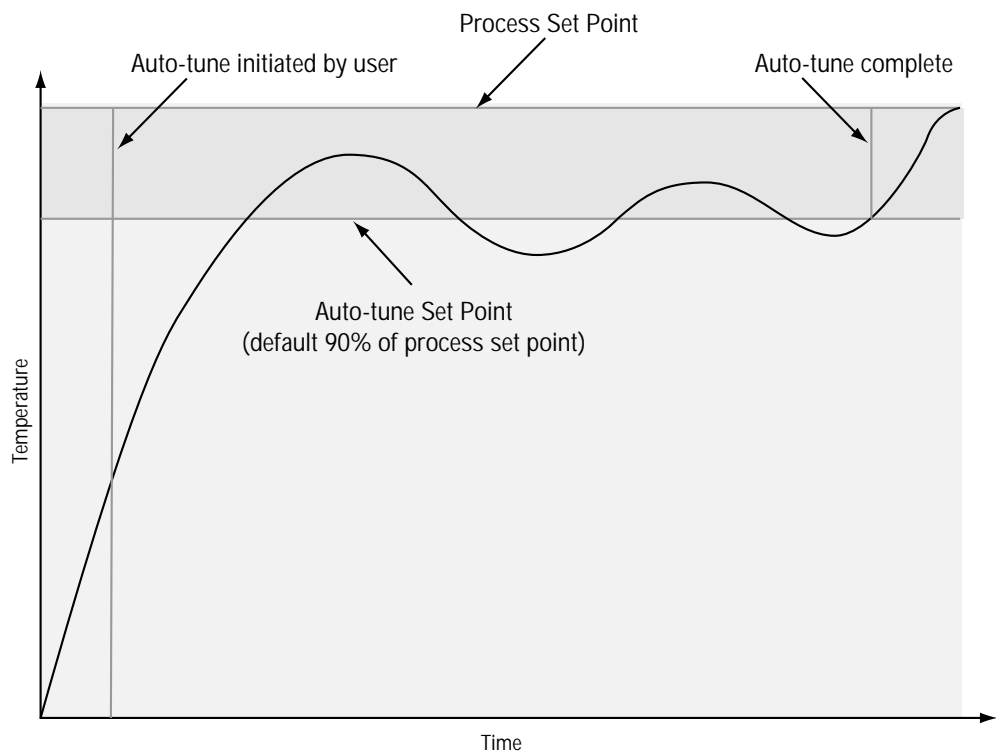

Figure 4.2 — Auto-tuning

Power Limit

A high side power limit and low side power limit set the maximum output power within two ranges

A low side power limit limits the output to a percentage of the maximum output power while the process temperature or value is below the power limit set point.

The high side power limit limits the output to a percentage of the maximum output power while the process temperature or value is above the power limit set point.

The low side power limit can be viewed or changed with Low Side Power Limit (Control Output Group).

The high side power limit can be viewed or changed with High Side Power Limit (Control Output Group).

The power limit set point can be viewed or changed with Power Limit Set Point (Control Output Group).

The actual output power can be viewed with Output Power (Control Output Power Group).

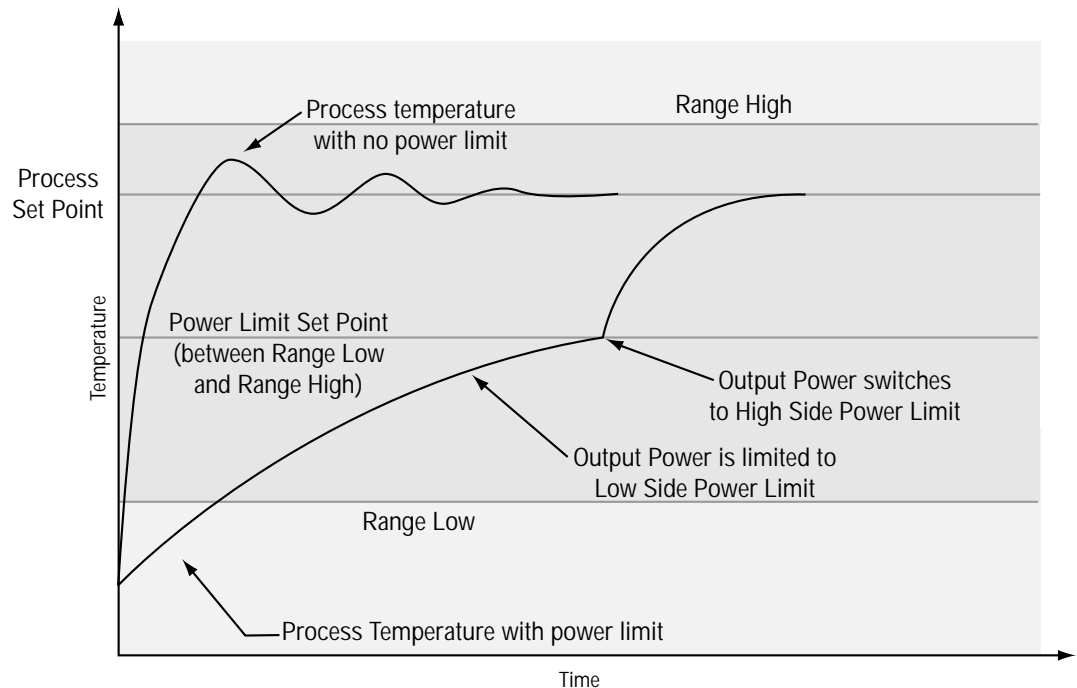

Figure 4.3 — Power Limits

Input

Calibration Offset

Calibration offset allows a device to compensate for an inaccurate sensor, lead resistance or other factors that affect the input value. A positive offset increases the input value, and a negative offset decreases the input value.

The input offset value can be viewed or changed with Calibration Offset (Input Group).

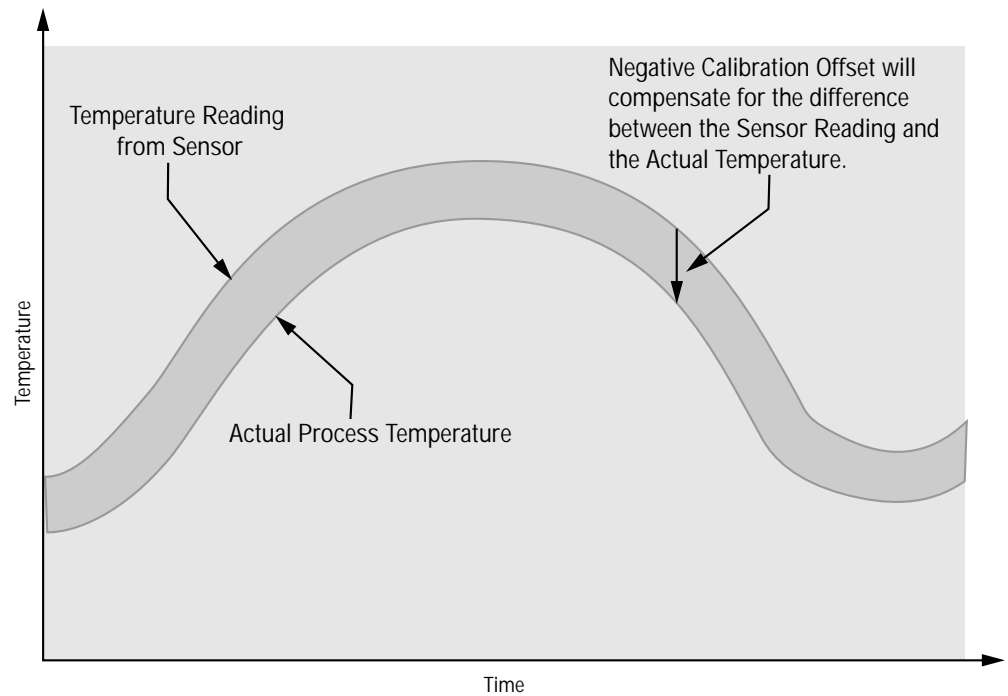

Figure 4.4 — Calibration Offset

Filter Time Constant

A time filter smooths an input signal by sampling the input at designated time intervals. Either the viewed value or both the viewed and control values can be filtered.

View or change the time filter with Filter Time Constant (Input Group). A positive value affects only the viewed values. A negative value affects both the viewed and control values. The filter is a single pole low pass.

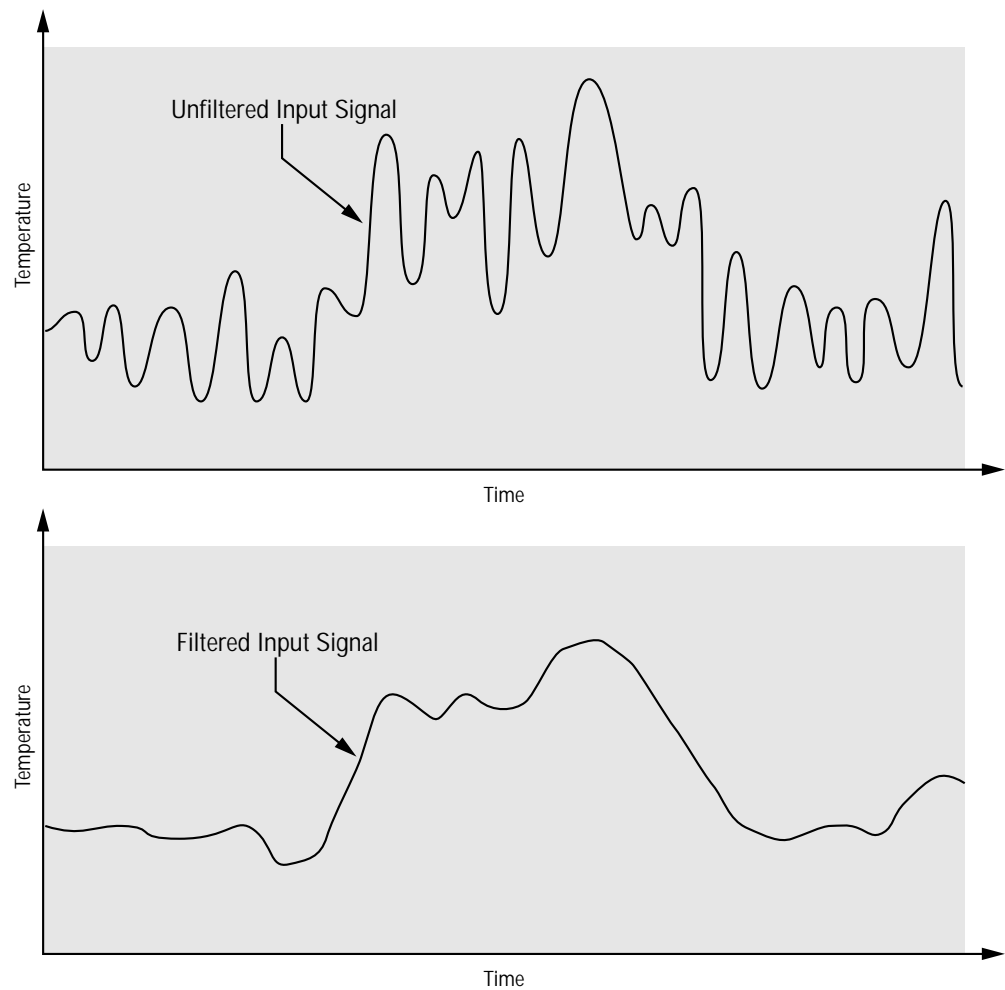

Figure 4.5 — Filtered and Unfiltered Input Signals

Sensor Selection

You need to configure a controller to match the input device, which is normally a thermocouple or RTD. When you select an input device the controller automatically sets the input linearization to match the sensor. It also sets high and low limits, which in turn limit the range high and range low values.

Use Sensor Type and Input Type (Input Group) to select the appropriate sensor.

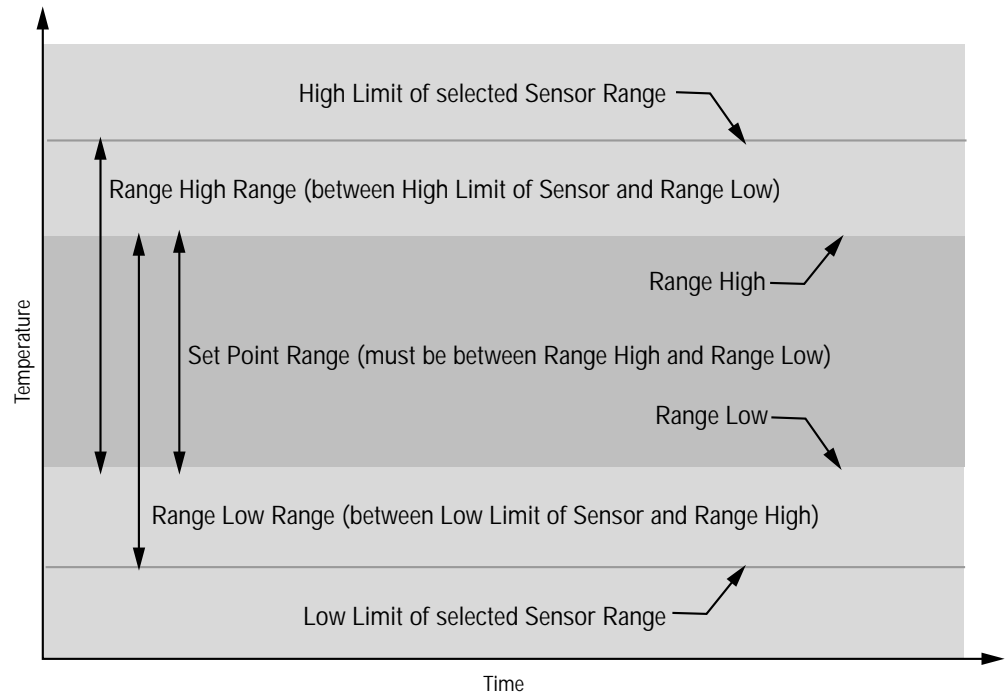

Figure 4.6 — Sensor Ranges

Range Low and Range High

The controller constrains the set point to a value between range high and range low. Range high cannot be set higher than the sensor high limit or lower than range low. Range low cannot be set lower than the sensor low limit or higher than range high.

Use Set Point (Operation Group), Range High and Range Low (Input Group) to select or view values for the corresponding parameters.

Control Methods

On/Off Control

On/off control switches the output either full on or full off, depending on the input, set point and hysteresis values. The hysteresis value creates a buffer zone that increases the time interval that the output is off or on. With hysteresis set to 0 the process value would stay closer to the set point, but the output would switch on and off more frequently, causing “chattering.”

Set hysteresis with Output Hysteresis (PID Group).

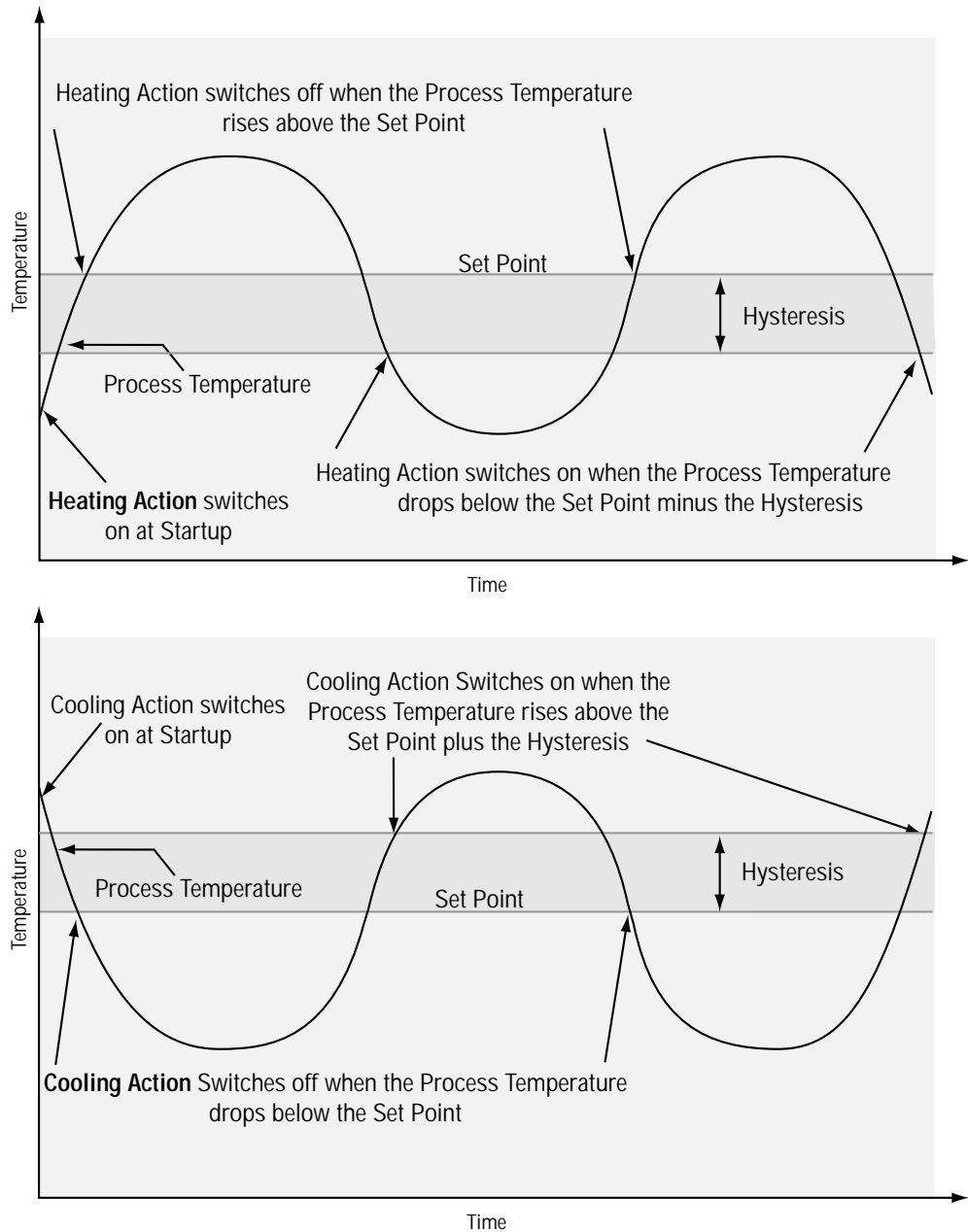

Features

Figure 4.7 — On/Off Control for Heating and Cooling

Proportional Control

Some processes need to maintain a temperature or process value closer to the set point than on/off control can provide. Proportional control provides closer control by adjusting the output when the temperature or process value is within a proportional band. When the value is in the band, the controller adjusts the output based on how close the process value is to the set point: the closer to set point the lower the output. This is similar to backing off on the gas pedal of a car as you approach a stop sign. It keeps the temperature or process value from swinging as widely as it would with simple on/off control. However, when a system settles down, the temperature or process value tends to “droop” short of the set point.

The proportional band can be viewed or changed with Propband (PID Group). To only view the proportional control value use Proportional Term (PID Group).

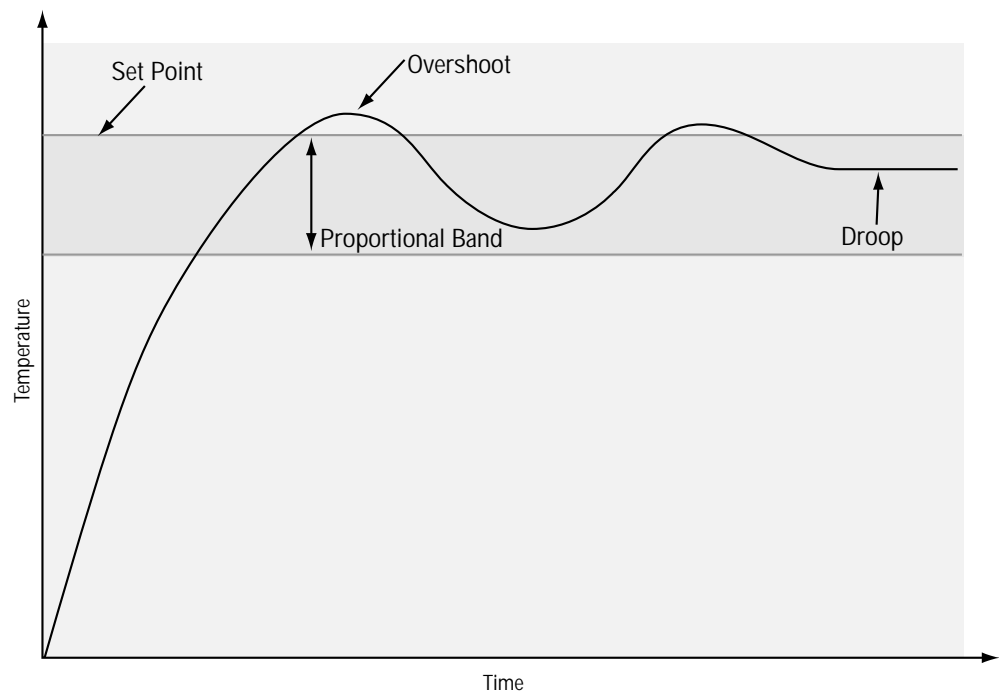

Figure 4.8 — Proportional Control

Proportional plus Integral (PI) Control

The droop caused by proportional control can be corrected by adding integral (reset) control to the system. When the system has settled down the integral (reset) value is tuned to bring the temperature or process value closer to the set point. However, this may increase the overshoot that occurs at startup or when the set point is changed. Used more with fast, high loss loads.

View or change the integral or reset value with Integral or Reset. To only view the integral control value use Integral Term (PID Group).

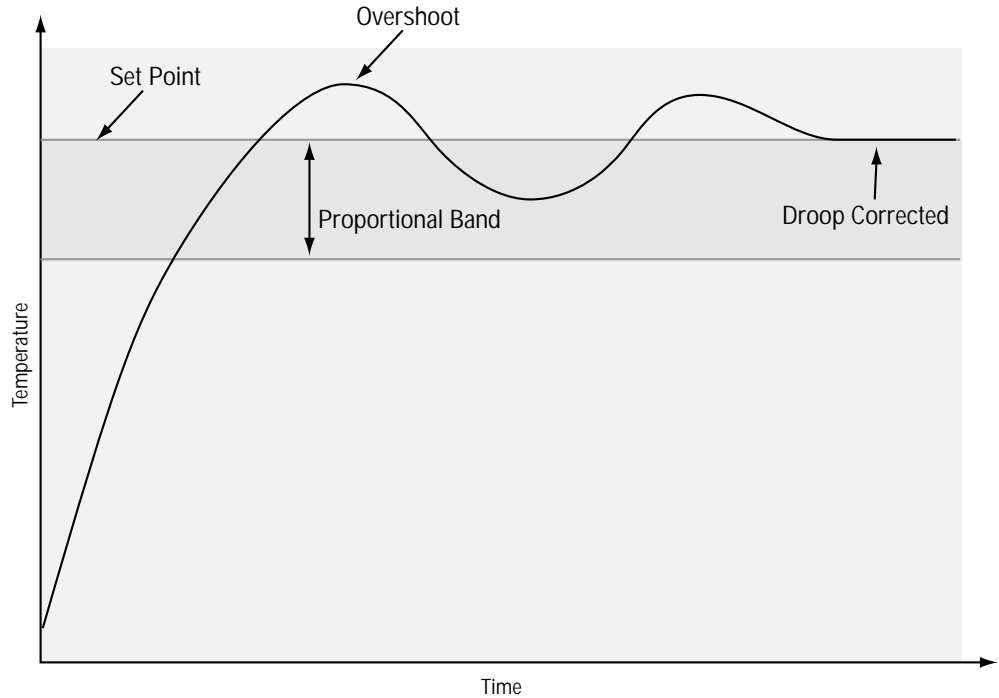

Figure 4.9 — Proportional plus Integral Control

Proportional plus Integral plus Derivative (PID) Control

Use derivative (rate) control to minimize the overshoot in a PI-controlled system. Derivative (rate) adjusts the output based on the rate of change in the temperature or process value. Used more with slow, lagging loads.

View or change derivative or rate with Derivative or Rate (PID Group). To only view the derivative control value use Derivative Term (PID Group).

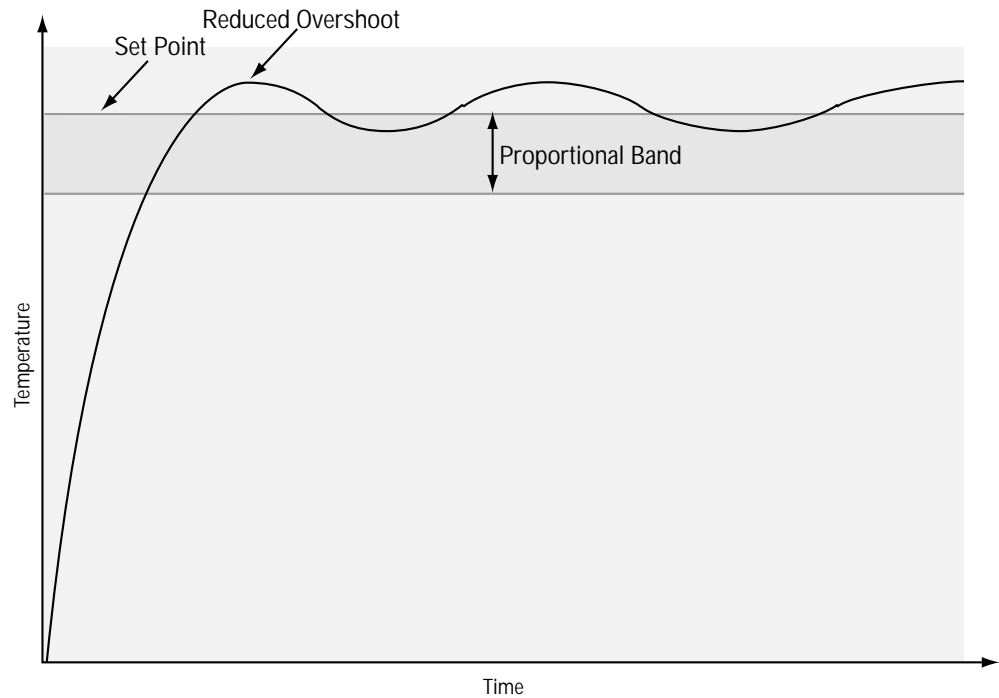

Figure 4.10 — PID Control

Alarms

An alarm takes some action, usually notifying an operator, when the process temperature leaves a defined range. A user can configure how and when an alarm is triggered and whether it turns off automatically when the alarm condition is over.

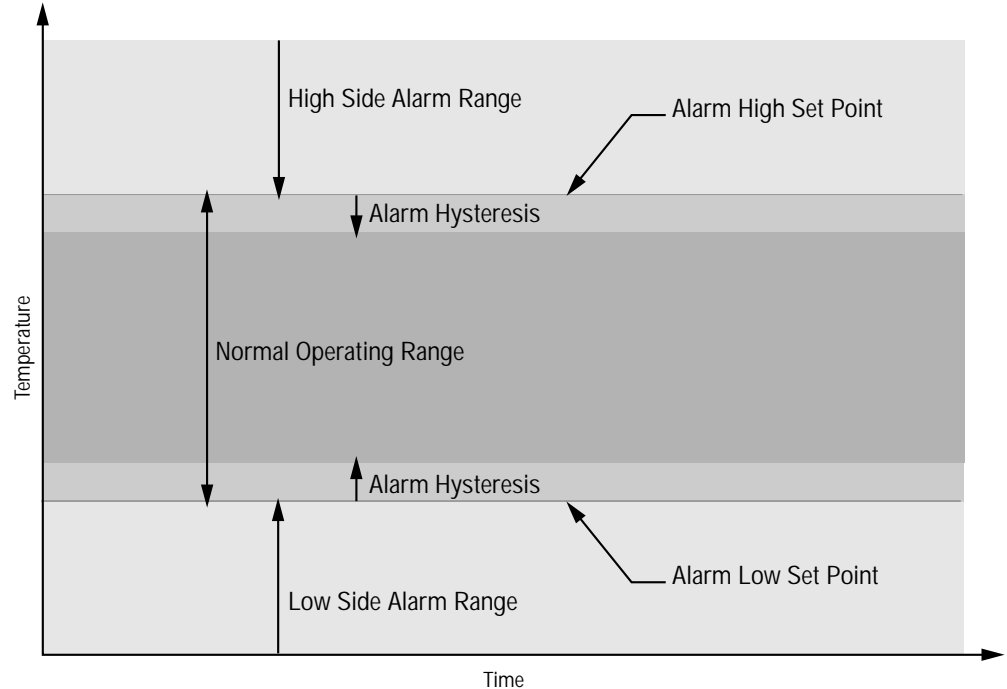

Figure 4.11 — Alarm Settings

Alarm Set Points

The alarm high set point defines the temperature or process value that will trigger a high side alarm. The alarm high set point must be higher than the alarm low set point and lower than the high limit of the sensor range.

The alarm low set point defines the temperature or process value that will trigger a low side alarm. The alarm low set point must be lower than the alarm high set point and higher than the low limit of the sensor range.

Alarm set points or deviation can be viewed or changed with Alarm High and Alarm Low (Alarm Output Group).

Alarm Hysteresis

Alarm hysteresis is a zone defined by adding an hysteresis value to the alarm low set point or subtracting the hysteresis value from the alarm high set point.

Once an alarm has occurred it will not clear until the process value is above the alarm-low setting or below the alarm-high settings by a margin equal to the hysteresis. Example: An alarm starts when the process value reaches the alarm high setting. The alarm will not clear until it is below the high setting by an amount equal to or greater than the alarm hysteresis.

The alarm hysteresis value can be viewed or changed with Alarm Hysteresis (Alarm Output Group).

Process or Deviation Alarms

A process alarm uses one or two fixed set points to define an alarm condition.

A deviation alarm uses one or two set points that are defined relative to the control set point. High and low alarm set points are calculated by adding and/or subtracting offset values from the control set point. If the set point changes, the alarm set points automatically change with it.

Alarm Type (Alarm Output Group) allows you to view or change whether the alarm will function as a process or deviation alarm.

The alarm deviation value can be viewed or changed with Alarm High and Alarm Low (Alarm Output Group).

Alarm Latching

A latched alarm will remain active after the alarm condition has passed. It can only be deactivated by the user. An alarm that is not latched will deactivate automatically when the alarm condition has passed.

Alarm Latching Mode (Alarm Output Group) allows you to view or change whether an alarm will latch.

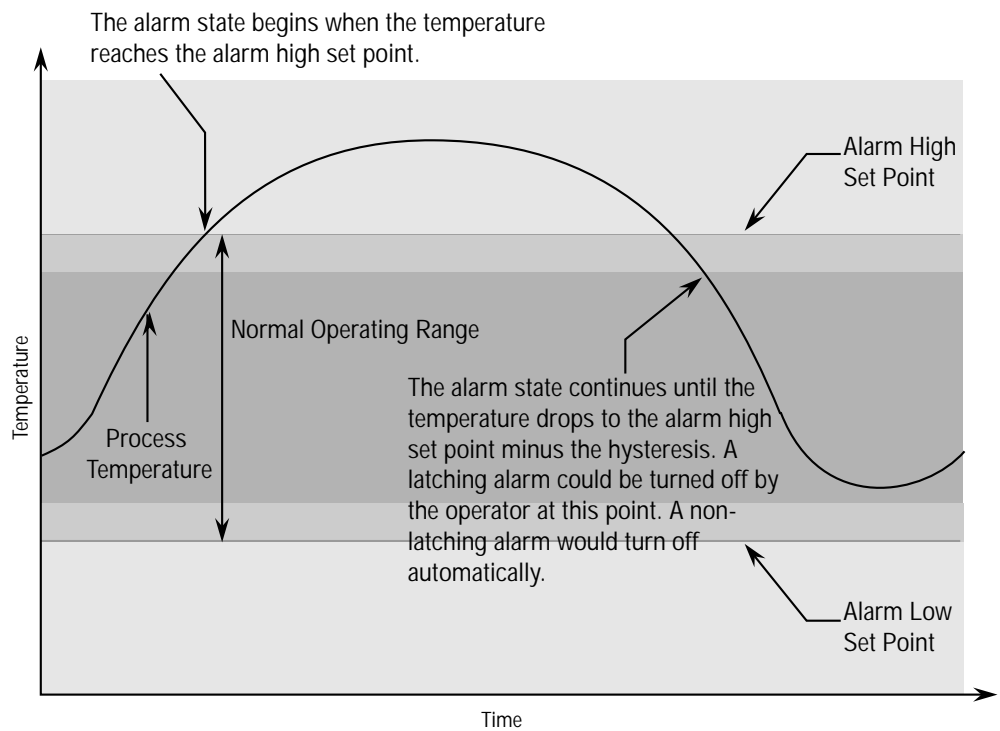

Figure 4.12 — Alarm Latching

Alarm Silencing

Alarm silencing has two uses:

1. It is often used to allow a system to warm up after it has been started up. With alarm silencing on, an alarm is not triggered when the process temperature is initially lower than the alarm low set point. The process temperature has to enter the normal operating range beyond the hysteresis zone in order to activate the alarm function.
2. Alarm silencing also allows the operator to disable the alarm output while the controller is in an alarm state. The process temperature has to enter the normal operating range beyond the hysteresis zone in order to activate the alarm function.

Alarm Silencing Mode (Alarm Output Group) allows you to view or change whether alarm silencing is on.

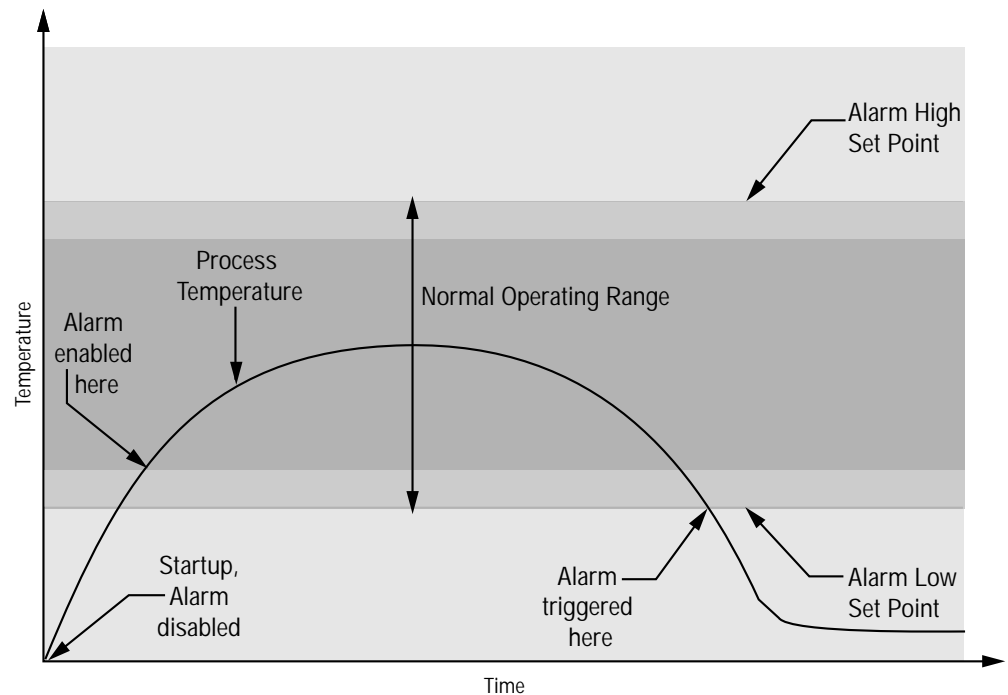

Figure 4.13 — Alarm Silencing

Errors

Panel Indicator Lights

Figure 4.14 - Error Information



Error Information — Unison Green/Red Flashing Code

ERROR 4 5 6 7 11 12 13 14 15

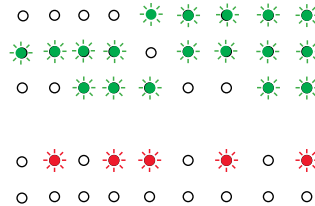

- Error 4 RAM malfunction (return to factory)
- Error 5 EEPROM data corrupted
- Error 6 PROM malfunction (return to factory)
- Error 7 SPI failure, onboard peripheral hardware not responding
- Error 11 New software installed (cycle power to correct)
- Error 12 Cal EEPROM checksum, calibration data corrupted (recalibrate)
- Error 13 A-to-D hardware fail, A-to-D hardware not responding (return to factory)
- Error 14 EEPROM hardware fail, EEPROM peripheral not responding (return to factory)
- Error 15 New unit, displays on first power up (return to factory)

Open Loop Detect

Open loop detect can alert the user of trouble on the input or output side of the control loop. An open loop error is triggered when 100 percent power is applied at the control output for a period of time equal to the setting of integral (PID Group), or when reset without the input registering a 5° (F or C) change.

If an open loop error occurs, shut down the system, check the input and control output wiring and check the input and output devices.

The open loop detect feature can be turned on or off with Activate Open Loop Detect (Error Group). Use Open Loop Error (Error Group) to check for an open loop condition.

Bumpless Transfer

When the sensor opens (fails), the MicroDIN switches from automatic to manual operation.

When transferring from automatic to manual operation, the control output, or outputs, remain stable — a bumpless, or smooth, transition.

If the Input Error Action parameter is set to 0, bumpless transfer, and the process has stabilized at a power level less than 75% ($\pm 5\%$) for a two-minute period prior to the sensor break, then the MicroDIN switches to manual operation at the last automatic power level. If these conditions are not met, the output goes to 0% power (output disabled).

If the Input Error Action parameter is set to Fixed Manual Output, the MicroDIN switches to manual operation at the Fixed Manual Output percent power value.

Manual operation provides open-loop control of the outputs from a range of -100% to 100% output. The MicroDIN allows a negative output value only when Output 1 is set to cool.

Automatic operation provides closed-loop on/off or PID control. When the operator transfers from a closed loop to an open loop, the MicroDIN sets the power level to the setting of the Input Error Action parameter. If Input Error Action is set to 0, bumpless transfer, the controller retains the power level from the closed-loop control. When the MicroDIN returns to closed-loop control, it restores the previous set point process value.

Figure 4.15 — Bumpless Transfer

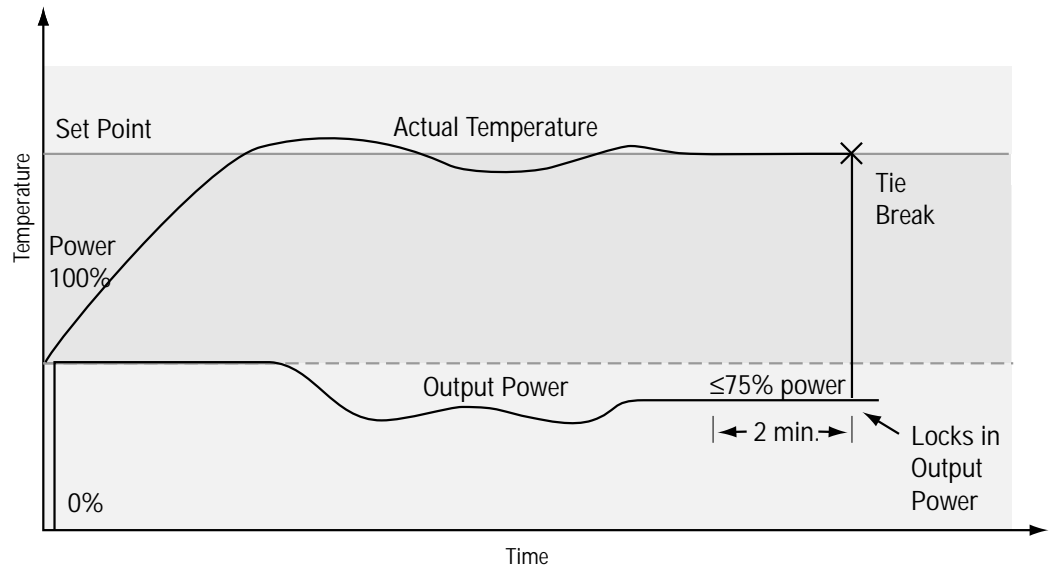



Notes

Chapter Five

Learn the Parameters

System Group	5.2	PID Group	5.13	Characteristics Group ..	5.25
Ambient (CJC) Temperature (1500) ..	5.2	PID Output Power (204)	5.13	Date of Manufacture (5).....	5.25
Non-volatile Memory (24)	5.2	Auto-tune Set Point (304)	5.13	Ship Date (6).....	5.25
Units Type (900)	5.3	Initiate Auto-tune (305)	5.14	Serial Number 1 (1).....	5.25
C or F (901).....	5.3	Proportional Band (500).....	5.14	Serial Number 2 (2).....	5.26
Decimal Point (606).....	5.3	Integral (501)	5.14	Software ID Number (3)	5.26
		Reset (502)	5.15	Software Revision (4)	5.26
		Derivative (503)	5.15		
		Rate (504).....	5.15		
Input Group	5.4	Cycle Time (506).....	5.16	Diagnostics Group	5.27
Input Actual (100)	5.4	Control Output Hysteresis (507) ..	5.16	Model Number (0)	5.27
Input Error (101).....	5.4			Ambient (CJC) A-to-D Counts (1501)	5.27
Sensor Type (600)	5.5			Input A-to-D Counts (1504)	5.27
Input Type (601)	5.5	Alarm Output Group	5.17	RTD Lead Compensation Analog-to-	
Range Low (602).....	5.6	Alarm Condition (106).....	5.17	Digital Counts (1502)	5.28
Range High (603).....	5.6	Alarm Output Hardware (17)	5.18	RTD Lead Resistance (1503)	5.28
Calibration Offset (605)	5.6	Clear Alarm On/Off (331).....	5.18	Proportional Term (205).....	5.28
Filter Time Constant (604)	5.7	Silence Alarm On/Off (332).....	5.18	Integral Term (206)	5.28
Input Error Action (902)	5.7	Alarm Low (321).....	5.19	Derivative Term (207)	5.29
		Alarm High (322)	5.19	Enter Diagnostics Mode (1512) ...	5.29
		Alarm Output Function (717).....	5.20	Test Displays (1513)	5.29
		Alarm Type (719).....	5.20	Test Outputs (1514).....	5.29
		Alarm Hysteresis (720)	5.20		
Control Output Group	5.8	Alarm Active Sides (723).....	5.20		
Output Power (103)	5.8	Alarm Latching Mode (721).....	5.21	Calibration Group	5.30
Control Output Hardware (16)	5.8	Alarm Silencing Mode (722)	5.21	Enter Calibration Mode (1600)....	5.30
Control Output Function (700).....	5.8	Alarm Logic (724)	5.21	Calibration Commands (1603)....	5.30
Power Limit Set Point (713)	5.9			Restore to Factory	
High Side Power (714)	5.9			Calibration (1601).....	5.31
Low Side Power (715).....	5.10			Reset Factory Defaults (1602)	5.31
Fixed Manual Output (903)	5.10				
		Error Group	5.22		
		Open Loop Error (210)	5.22		
		Open Loop Detect (904).....	5.22		
Operation Group	5.11	Input Error (101).....	5.23		
Operation Mode (200).....	5.11	System Error (209).....	5.23		
User Operation Mode (301).....	5.11	Clear Error (311)	5.23		
User Set Point (300).....	5.12	Input Error Action (902)	5.24		
Manual Output Power (310)	5.12	Error Clearing Mode (607).....	5.24		

System Group

Monitor

Ambient (CJC) Temperature [5.2](#)

Use

Non-volatile Memory [5.2](#)

Setup

Units Type [5.3](#)

C or F [5.3](#)

Decimal Point [5.3](#)



CAUTION:

Avoid writing continuously to EEPROM memory. Continuous writes may result in premature control failure, system downtime and damage to processes and equipment.

See Disable Non-volatile Memory (System Group).

System Group – Monitor

System Error

- See Error Group.

Ambient (CJC) Temperature

- Read the ambient temperature in 0.1 degrees Fahrenheit.
- Read only
- Modbus: 1500

Range

0.0 to 180.0 F

Default

none

Active

always

System Group – Use

Non-volatile Memory

- Disable storage of parameters to non-volatile (EEPROM) memory. This allows you to change parameters frequently without wearing out the memory.
- Read/write
- Modbus: 24

Range

0: store parameters when they are changed

1: do not store parameters when they are changed

Default

0 (always reverts to 0 when the controller's power is turned off and on)

Active

always

Affects

all parameters

will not save any parameters when set to 1.



System Group – Setup

Units Type

- Select US or SI units of measurement.
- Read/write
- Modbus: 900

Range

- 0: US (reciprocate integral term)
- 1: SI (reciprocate integral term)

Default

- 0: US

Active

- always

Affects

- Propband, Integral and Reset (PID Group)
- converts Reset and Integral (changes span to degrees or vice versa)

C or F

- Select the temperature scale for the input.
- Read/write
- Modbus: 901

Range

- 0: F (Fahrenheit)
- 1: C (Celsius)

Default

- 0: F

Active

- always

Decimal Point

- Sets the position of the decimal point for input readings.
- Read/write
- Modbus: 606

Range

- 0: decimal 0000 (for thermocouple and RTD)
- 1: decimal 000.0 (for for thermocouple and RTD)

Default

- 0

Active

- if Sensor Type (Input Group) is set to RTD or thermocouple

Input Group

Monitor

Input Actual [5.4](#)

Input Error [5.4](#)

Setup

Sensor Type [5.5](#)

Input Type [5.5](#)

Range Low [5.6](#)

Range High [5.6](#)

Calibration Offset [5.6](#)

Filter Time Constant [5.7](#)

Input Error Action [5.7](#)



CAUTION:

Avoid writing continuously to EEPROM memory. Continuous writes may result in premature control failure, system downtime and damage to processes and equipment.

See Disable Non-volatile Memory (System Group).

Input Group – Monitor

Input Actual

- Monitor the input value.
- During an input error state, this will read 9999 if Read Control Output (Control Output Group) is set to heat or -1999 if it is set to cool.
- Read only
- Modbus: 100

Range
input type range

Default
none

Active
always

Input Error

- Monitor the input error status.
- Read only
- Modbus: 101

Range
0: no error
1: analog-to-digital signal under range
2: sensor under range
3: sensor over range
4: analog-to-digital over range

Default
none

Active
always



Input Group – Setup

Sensor Type

- Select the input sensor type.
- Read/write
- Modbus: 600

Range

- 0: thermocouple
- 1: RTD

Default

- 0: thermocouple

Active

- always

Affects

Changes Input Type (Input Group) to J for thermocouple, DIN for RTD, and defaults temperature related parameters.

Input Type

- Set the linearization for the input sensor.
- Read/write
- Modbus: 601

Range

if Sensor Type (Input Group) set to thermocouple

- 0: J
- 1: K
- 2: T
- 3: E
- 4: N
- 5: C
- 6: D
- 7: PT2
- 8: R
- 9: S
- 10: B

if Sensor Type (Input Group) set to RTD

- 11: RTD_DIN
- 12: RTD_JIS

Default

if Sensor Type (Input Group) is changed to thermocouple: J
if Sensor Type (Input Group) is changed to RTD: DIN

Active

- always

Affected by

Changing Sensor Type sets to J for thermocouple, DIN for RTD, and defaults temperature related parameters

Range Low

- Set the input range low. This setting is the lowest value that the set point can have.
- Read/write
- Modbus: 602

Range

see Sensor Table in the Appendix for sensor ranges and defaults

Default

see Sensor Table in the Appendix for sensor ranges and defaults

Active

always

Affects

Set Point (Operation Group) limits the set point to the range between Range Low and Range High (Input Group)

Range High

- Set the input range high. This setting is the highest value that the set point can have.
- Read/write
- Modbus: 603

Range

see Sensor Table in the Appendix for sensor ranges and defaults

Default

see Sensor Table in the Appendix for sensor ranges and defaults

Active

always

Affects

Set Point (Operation Group) limits the set point to the range between Range Low and Range High (Input Group)

Calibration Offset

- Set the input calibration offset. This allows you to compensate for lead resistance, sensor errors and other factors.
- Read/write
- Modbus: 605

Range

-1999 to 9999

Default

0

Active

always



Filter Time Constant

- Set the filter time for the input, in seconds. This smooths out a rapidly changing input signal. Positive values affect the monitor readings only. Negative values affect both the monitor readings and the control values.
- Read/write
- Modbus: 604

Range

-60.0 to 60.0

Default

0.0

Active

always

Input Error Action

- Select how the controller responds to an input error.
- Read/write
- Modbus: 902

Range

0: bumpless transfer (control output power remains constant, see [Chapter 5](#))

1: switch to the Fixed Manual Output (Control Output Group) setting

2: shut off output

Default

0: bumpless transfer

Active

always

Control Output Group

Monitor

Output Power [5.8](#)

Control Output Hardware [5.8](#)

Setup

Control Output Function [5.8](#)

Power Limit Set Point [5.9](#)

High Side Power [5.9](#)

Low Side Power [5.9](#)

Fixed Manual Output [5.10](#)



CAUTION:
Avoid writing continuously to EEPROM memory. Continuous writes may result in premature control failure, system downtime and damage to processes and equipment.

See Disable Non-volatile Memory (System Group).

Control Output Group – Monitor

Output Power

- Monitor the control output power level. This can limit PID Output Power (PID Group).

- Read only

- Modbus: 103

Range

heat: 0.0 to 100.0

cool: -100.0 to 0.0

Default

none

Active

always

Control Output Hardware

- Read the control output hardware type.

- Read only

- Modbus: 16

Range

3: dc

Default

3

Active

always

Control Output Group – Setup

Control Output Function

- Select whether the control output will control for heating or cooling.

- Read/write

- Modbus: 700



Control Output Group continued

Range

0: heat
1: cool

Default

0: heat

Active

always

Affects

Manual Output Power (Operation Group) determines heat or cool values.

High Side Power, Low Side Power or Fixed Manual Output (Control Output Group) changes range

Power Limit Set Point

- Select the set point that High Side Power and Low Side Power (Control Output Group) will use to limit the control output range.
- Read/write
- Modbus: 713

Range

Range Low to Range High (Input Group) values

Default

Range High

Active

always

High Side Power

- Set the maximum allowed power above the Power Limit Set Point (Control Output Group).
- Read/write
- Modbus: 714

Range

heat: 0.0 to 100.0
cool: -100.0 to 0.0

Default

heat: 100.0
cool: -100.0

Active

always

Affected by

Changing Control Output Function (Control Output Group) changes range.

Low Side Power

- Set the maximum allowed power below the Power Limit Set Point (Control Output Group).
- Read/write
- Modbus: 715

Range

heat: 0.0 to 100.0
cool: -100.0 to 0.0

Default

heat: 100.0
cool: -100.0

Active

always

Affected by

Changing Control Output Function (Control Output Group)
changes range

Fixed Manual Output

- Select the initial control output power to take effect when the controller is switched to manual mode by either the user or an error.
- Read/write
- Modbus: 903

Range

heat: 0.0 to 100.0
cool: -100.0 to 0.0

Default

0.0

Active

always

Affected by

Changing Control Output Function (Control Output Group)
changes range



Operation Group

Monitor

Operation Mode [5.11](#)

Use

Operation Mode [5.11](#)

User Set Point [5.12](#)

Manual Output Power [5.12](#)



CAUTION:
Avoid writing continuously to EEPROM memory. Continuous writes may result in premature control failure, system downtime and damage to processes and equipment.

See Disable Non-volatile Memory (System Group).

Operation Group – Monitor

Operation Mode

- Monitor the operation mode. Normally follows the user selected mode. It returns to the previous state after an error clears.
- Read only
- Modbus: 200

Range

- 0: off
- 1: auto
- 2: manual control (user selected)
- 3: manual control (due to error)

Default

auto

Active

always

Operation Group – Use

User Operation Mode

- Select whether the controller is under auto or manual control.
- Read/write
- Modbus: 301

Range

- 0: auto
- 1: manual

Default

0: auto

Active

always

Affects

Manual Output Power (Operation Group) manual or manual due to error

User Set Point

- Change or monitor the control set point.
- Read/write
- Modbus: 300

Range

Range Low to Range High (Input Group)

Default

75°F, 24°C

Active

if Operation Mode (Operation Group) is set to auto

Affected by

Changing Sensor Type (Input Group) determines range of setting and default

Changing Input Type (Input Group) determines range of setting and default

Changing Range Low (Input Group) determines range of setting and default

Changing Range High (Input Group) determines range of setting and default

Changing C or F (System Group) determines range of setting and default

Manual Output Power

- Set the control output power manually.
- Read/write
- Modbus: 310

Range

0.0 to 100.0: heat mode

-100.0 to 0.0: cool mode

Default

0.0

Active

if Operation Mode (Operation Group) is set to manual or switches to manual due to error

Affected by

Changing Operation Mode (Operation Group) to manual or manual due to error

Changing Control Output Function (Alarm Output Group) determines range of setting



PID Group

Monitor

PID Output Power [5.13](#)

Initiate Auto-tune [5.14](#)

Setup

Auto-tune Set Point [5.13](#)

Proportional Band [5.14](#)

Integral [5.14](#)

Reset [5.15](#)

Derivative [5.15](#)

Rate [5.15](#)

Cycle Time [5.15](#)

Control Output Hysteresis [5.16](#)

PID Group – Monitor

PID Output Power

- Monitor the calculated PID power level. See [Chapter 4](#) for information about PID control.
- Read only
- Modbus: 204

Range

heat: 0.0 to 100.0
cool: -100.0 to 0.0

Default

none

Active

always

PID Group – Use

Auto-tune Set Point

- Set the auto-tune set point as a percent of the currently active set point.
- Read/write
- Modbus: 304

Range

50 to 150

Default

90

Active

always



CAUTION:
Avoid writing continuously to EEPROM memory. Continuous writes may result in premature control failure, system downtime and damage to processes and equipment.

See Disable Non-volatile Memory (System Group).

Initiate Auto-tune

- Initiate or cancel an auto-tune.
- Read/write
- Modbus: 305

Range

0: off or cancel an auto-tune in progress
1: initiate an auto-tune

Default

0: off

Active

if Operation Mode (Operation Group) is set to auto

Affected by

Changing Operation Mode (Operation Group) available when mode is set to auto

PID Group – Setup

Proportional Band

- Set the proportional band for PID control. See [Chapter 4](#) for information about PID control.
- Read/write
- Modbus: 500

Range

0: on/off control mode
1-9999°F or °C: proportional control mode

Default

25°F, 17°C

Active

always

Integral

- Set the integral time for PID control. See [Chapter 4](#) for information about PID control.
- Read/write
- Modbus: 501

Range

0.00 to 99.99 minutes

Default

0.00

Active

if Propband (PID Group) is not set to 0 and Units Type (System Group) is set to SI

Affected by

Changing Units Type (System Group) will convert Integral to Reset.

Reset

- Set the reset time for PID control. See [Chapter 4](#) for information



PID Group continued

about PID control.

- Read/write
- Modbus: 502

Range

0.00 to 99.99 minutes per repeat

Default

0.00

Active

if Propband (PID Group) is not set to 0 and Units Type (System Group) is set to US

Affected by

Changing Units Type (System Group) will convert Integral to Reset.

Derivative

- Set the derivative time for PID control. See [Chapter 4](#) for information about PID control.
- Read/write
- Modbus: 503

Range

0.00 to 9.99 minutes

Default

0.00

Active

if Propband (PID Group) is not set to 0 and Units Type (System Group) is set to SI

Rate

- Set the rate time for PID control. See [Chapter 4](#) for information about PID control.
- Read/write
- Modbus: 504

Range

0.00 to 9.99 minutes

Default

0.00

Active

if Propband (PID Group) is not set to 0 and Units Type (System Group) is set to US

Cycle Time

- Set the control output cycle time in seconds.
- Read/write
- Modbus: 506

Range
0.1 to 60.0 seconds

Default
2.0

Active
if Propband (PID Group) is not set to 0 and Units Type (System Group) is set to US

Control Output Hysteresis

- Set the control output switching hysteresis.
- Read/write
- Modbus: 507

Range
1 to 9999°F or °C

Default
3

Active
only if Propband is set to 0



Alarm Output Group

<i>Monitor</i>	
Alarm Condition	5.17
Alarm Output Hardware	5.17
<i>Use</i>	
Clear Alarm	5.18
Silence Alarm	5.18
<i>Setup</i>	
Alarm Low	5.18
Alarm High	5.19
Alarm Output Function	5.19
Alarm Type	5.19
Alarm Hysteresis	5.20
Alarm Active Sides	5.20
Alarm Latching Mode	5.20
Alarm Silencing Mode	5.21
Alarm Logic	5.21



CAUTION:
Avoid writing continuously to EEPROM memory. Continuous writes may result in premature control failure, system downtime and damage to processes and equipment.

See Disable Non-volatile Memory (System Group).

Alarm Output Group – Monitor

Alarm Condition

- Monitor the alarm state.
- Read only
- Modbus: 106

Range

- 0: no alarm
- 1: high alarm
- 2: low alarm
- 3: high latched alarm
- 4: low latched alarm
- 5: high silenced alarm
- 6: low silenced alarm
- 7: high latched silenced alarm
- 8: low latched silenced alarm
- 9: waiting for in range alarm
- 10: disabled alarm
- 11 error alarm

Default

none

Active

always

*Alarm Output Group continued***Alarm Output Hardware** 

- Read the alarm output hardware type.
- Read only
- Modbus: 17

Range

1: mechanical relay

Default

1

Active

always

*Alarm Output Group – Use***Clear Alarm** 

- Alarm will clear if alarm condition is resolved
- Read/write
- Modbus: 331

Range

0: no action

1: try to clear a latched alarm

Default

0 (always reverts to 0 after a write)

Active

if Alarm Latching Mode (Alarm Output Group) is set to yes

Silence Alarm 

- Silence the alarm manually.
- Read/write
- Modbus: 332

Range

0: no action

1: silence alarm

Default

0 (always reverts to 0 after a write)

Active

always



Alarm Output Group – Setup

Alarm Low

- Set the low alarm set point.
- Read/write
- Modbus: 321

Range

process: sensor range low to Alarm High (Alarm Output Group)
deviation: -1999 to -1

Default

process: sensor range low
deviation: -1999

Active

if Alarm Output Function (Alarm Output Group) is set to alarm

Affected by

Sensor Type (Input Group) determines range of setting and default.

Input Type (Input Group) determines range of setting and default.

Alarm Type (Alarm Output Group) determines range of setting and default.

C or F (System Group) converts and determines range of setting.

Alarm High

- Set the high alarm set point
- Read/write
- Modbus: 322

Range

process: Alarm Low (Alarm Output Group) to sensor range high
deviation: 1 to 9999

Default

process: sensor range high
deviation: 9999

Active

if Alarm Output Function (Alarm Output Group) is set to alarm

Affected by

Sensor Type (Input Group)
determines range of setting and default

Input Type (Input Group)
determines range of setting and default

Alarm Type (Alarm Output Group)
determines range of setting and default

C or F (System Group)
converts and determines range of setting

*Alarm Output Group continued***Alarm Output Function** 

- Turn the alarm output on or off.
- Read/write
- Modbus: 717

Range

0: off
1: alarm

Default

0: off

Active

always

Alarm Type 

- Select alarm type. A process alarm responds when the temperature leaves a fixed range. A deviation alarm responds when the temperature deviates from the set point by a set number of degrees.
- Read/write
- Modbus: 719

Range

0: process alarm
1: deviation alarm

Default

0: process

Active

if Alarm Output Function (Alarm Output Group) is set to alarm

Affects

Alarm Low (Alarm Output Group) changes to sensor low for process alarms or -1999 for deviation alarm.

Alarm High (Alarm Output Group) changes to sensor high for process alarms or 9999 for deviation alarm.

Alarm Hysteresis 

- Sets the switching hysteresis for the alarm output. This defines a band on the inside of the alarm set point. When the process temperature is in this band, the alarm state will not change.
- Read/write
- Modbus: 720

Range

1 to 9999

Default

3

Active

if Alarm Output Function (Alarm Output Group) is set to alarm

Alarm Active Sides 

- Select which side or sides the alarm is active on.
- Read/write
- Modbus: 723



Alarm Output Group continued

Range

- 0: both
- 1: high side only
- 2: low side only

Default

0: both

Active

if Alarm Output Function (Alarm Output Group) is set to alarm

Alarm Latching Mode

- Turn alarm latching on or off. When latching is active, the alarm will remain on after the alarm condition ends. It must be turned off manually.
- Read/write
- Modbus: 721

Range

- 0: no
- 1: yes

Default

0: no

Active

if Set Alarm Output Function (Alarm Output Group) is set to alarm

Alarm Silencing Mode

- Turn alarm silencing on or off. When silencing is active and the controller is first turned on, the alarm cannot become active until the process temperature leaves the alarm range. Also, alarms can be manually silenced after one occurs. Entering the normal operation range resets the silence.
- Read/write
- Modbus: 722

Range

- 0: no
- 1: yes

Default

0: no

Active

if Alarm Output Function (Alarm Output Group) is set to alarm

Alarm Logic

- Select alarm output logic.
- Read/write
- Modbus: 724

Range

- 0: alarm condition de-energizes output (open)
- 1: alarm condition energizes output (closed)

Default

0

Active

if Alarm Output Function (Alarm Output Group) is set to alarm

Error Group

Monitor

Open Loop Error	5.22
Open Loop Detect	5.22
Input Error	5.22
System Error	5.23

Use

Clear Error	5.23
-------------------	----------------------

Setup

Input Error Action	5.24
Error Clearing Mode	5.24



CAUTION:

Avoid writing continuously to EEPROM memory. Continuous writes may result in premature control failure, system downtime and damage to processes and equipment.

See Disable Non-volatile Memory (System Group).

Error Group – Monitor

Open Loop Error

- Read the open loop error status. An open loop indicates that the output is not responding appropriately to the input.

- Read only
- Modbus: 210

Range

- 0: no error
- 1: open loop error detected

Default

none

Active

always

Open Loop Detect

- Turn the open loop detect feature on or off.
- Read/write
- Modbus: 904

Range

- 0: off
- 1: on

Default

0: off

Active

always

Affects

Read Open Loop Error (Error Group) must be on to activate Read Open Loop Error



Error Group continued

Input Error (see also Input Group)

- Monitor the input error status.
- Read only
- Modbus: 101

Range

- 0: no error
- 1: analog-to-digital signal under range
- 2: sensor under range
- 3: sensor over range
- 4: analog-to-digital over signal range

Default

none

Active

always

System Error

- Read the system error status.
- Read only
- Modbus: 209

Range

- 0: no error
- 4: RAM error
- 5: non-volatile checksum error
- 6: PROM error
- 7: hardware failure
- 11: software version change
- 12: calibration checksum error
- 13: analog-to-digital failure
- 14: non-volatile hardware failure
- 15: new unit

Default

none

Active

always

Error Group – Use

Clear Error

- Try to clear a latched input error.
- Read/write
- Modbus: 311

Range

- 0: no action
- 1: try to clear latched input error

Default

0 (always reverts after a write)

Active

always

Error Group – Setup

Input Error Action (see also Input Group)

- Select how the controller responds to an input error.
- Read/write
- Modbus: 902

Range

- 0: bumpless transfer (control output power remains constant, [Chapter 4](#))
- 1: switch to the Fixed Manual Output (Control Output Group) setting
- 2: shut off output

Default

- 0: bumpless transfer

Active

- always

Error Clearing Mode

- Set the error clearing mode. When errors are latched, the error message or indicator persists until it has been cleared manually. Otherwise the error message or indicator clears automatically when the condition that caused it no longer exists.
- Read/write
- Modbus: 607

Range

- 0: not latched (errors clear automatically)
- 1: latched (errors must be cleared manually)

Default

- 0: errors clear automatically

Active

- always



Characteristics Group

Date of Manufacture	5.25
Ship Date	5.25
Serial Number 1	5.25
Serial Number 2	5.26
Software ID Number	5.26
Software Revision	5.26

Date Of Manufacture

- Read the manufacture date as week/year (WWYY).
- Read only
- Modbus: 005

Range

0596-9999 (5th week of 1996 to 52nd week of 1999)

Default

none

Active

always

Ship Date

- Read the ship date as week/year (WWYY).
- Read only
- Modbus: 006

Range

0596-9999 (5th week of 1996 to 52nd week of 1999)

Default

none

Active

always

Serial Number 1

- Read the first four digits of the serial number.
- Read only
- Modbus: 001

Range

0-9999

Default

0

Active

always

Characteristics Group continued

Serial Number 2

- Read the last four digits of the serial number.
- Read only
- Modbus: 002

Range
0-9999

Default
0

Active
always

Software ID Number

- Read the software ID number.
- Read only
- Modbus: 003

Range
0 to 9999

Default
none

Active
always

Software Revision

- Read software revision number.
- Read only
- Modbus: 004

Range
0.00 to 99.99

Default
none

Active
always



Diagnostics Group

Model Number	5.27
Ambient (CJC) A-to-D Counts	5.27
Input A-to-D Counts	5.27
RTD Lead Compensation A to D Counts .	5.28
RTD Lead Resistance	5.28
Proportional Term	5.28
Integral Term	5.28
Derivative Term	5.29
Enter Diagnostics Mode	5.29
Test Displays	5.29
Test Outputs	5.29



CAUTION:

Avoid writing continuously to EEPROM memory. Continuous writes may result in premature control failure, system downtime and damage to processes and equipment.

See Disable Non-volatile Memory (System Group).

Model Number

- Read the model number of the controller.
- Read only
- Modbus: 000

Range
8568 (ASCII 'uD')

Default
none

Active
always

Ambient (CJC) A-to-D Counts

- Read the raw ambient channel, analog-to-digital signal counts.
- Read only
- Modbus: 1501

Range
0 to 65535

Default
none

Active
always

Input A-to-D Counts

- Read the raw input analog-to-digital converter counts.
- Read only
- Modbus: 1504

Range
0 to 65535

Default
none

Active
always

RTD Lead Compensation Analog-to-Digital Counts

- Reads the raw, RTD lead compensation, analog-to-digital converter counts.
- Read only
- Modbus: 1502

Range
0 to 65535

Default
none

Active
always

RTD Lead Resistance

- Reads the measured RTD lead resistance in 0.01 ohms.
- Read only
- Modbus: 1503

Range
0.00 to 99.99

Default
none

Active
always

Proportional Term

- Monitor the proportional term. See [Chapter 4](#) for information about PID control.
- Read only
- Modbus: 205

Range
-100.0 to 100.0

Default
none

Active
always

Integral Term

- Monitor the integral term. See [Chapter 4](#) for information about PID control.
- Read only
- Modbus: 206

Range
heat: 0.0 to 100.0
cool: -100.0 to 0.0

Default
none

Active
always



Derivative Term

- Monitor the derivative term. See [Chapter 4](#) for information about PID control.
- Read only
- Modbus: 207

Range
-100.0 to 100.0

Default
none

Active
always

Enter Diagnostics Mode (Set)

- Enter the diagnostics mode to test indicator lights and outputs and to enter the calibration mode.
- Read/write
- Modbus: 1512

Range
0 to 1788 and 1790 to 9999: exit the diagnostics mode
1789: enter the diagnostics mode

Default
0

Active
always

Test Displays

- Test the indicator lights on the front panel.
- Read/write
- Modbus: 1513

Range
0: turn off all indicator lights
1: turn on the cyclic display test

Default
0

Active
if the controller is in the diagnostics mode

Test Outputs

- Test both outputs.
- Read/write
- Modbus: 1514

Range
0: turn both outputs off
1: turn the control output on and the alarm output off
2: turn the control output off and the alarm output on

Default
0

Active
if the controller is in diagnostics mode

NOTE:

See [page 6.6](#) for the calibration procedures.

 **CAUTION:**
Avoid writing continuously to EEPROM memory. Continuous writes may result in premature control failure, system downtime and damage to processes and equipment.

See [Disable Non-volatile Memory \(System Group\)](#).

Calibration Group

Enter Calibration Mode	5.30
Calibration Commands	5.30
Restore Factory Calibration	5.30
Reset Factory Defaults.....	5.31

Enter Calibration Mode

- Enter calibration mode, to calibrate the controller.
- Must be in diagnostics mode to enter calibration mode
- Read/write
- Modbus: 1600

Range

0 to 1414 and 1416 to 9999: exit calibration mode
1415: enter calibration mode

Default

0

Active

if the controller is in diagnostics mode

Calibration Commands

- Measure and store a selected input calibration value.
- Write
- Modbus: 1603

Range

0: no calibration
1: store 0.000mV input
2: store 50.000mV input
3: store CJC input (32°F Type J, compensated)
4: store ground input (S1, S2 and S3 shorted)
5: store RTD lead resistance (S1 and S2 shorted)
6: store 15.00 ohms
7: store 380.00 ohms
10: store 4mA input

Default

0

Active

if the controller is in calibration mode.



Restore to Factory Calibration (Set)

- Restore factory calibration values from the backup memory.

- Write

- Modbus: 1601

Range

0: no action

1: restore factory calibration

Default

0 (always reads 0)

Active

if the controller is in the calibration mode

Reset Factory Defaults (Set)

- Reset all parameters to factory values.

- Read/write

- Modbus: 1602

Range

0 to 799 and 801 to 999: no action

800: reset parameters to factory values

Default

0

Active

if the controller is in calibration mode

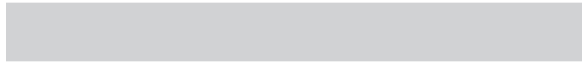

Notes

6

Chapter Six: Operation and Calibration



MicroDIN Startup	6.2
MicroDIN Shutdown	6.3
Troubleshooting Alarms and Errors	6.4
Calibrating the MicroDIN	6.6

MicroDIN Startup

Starting the Watlow MicroDIN for either one zone or several in any thermal system requires successful completion of this checklist:

- Units securely mounted ([see p. 3.3, 3.4](#))
- Proper sensor placement (see Watlow Application Guide)
- Correct input wiring ([see p. 3.5, 3.6](#))
- Correct communications wiring ([see p. 2.2 - 2.4, 3.5, 3.8, 3.9](#))
- Correct fusing installed ([see p. 3.10, 3.11](#))
- Correct limit protection installed ([see p. 3.10, 3.11](#))
- Correct power wiring ([see p. 3.5, 3.7, 3.10, 3.11](#))
- PC communication EIA-485 card, or PC communications card to EIA-485 converter with correct wiring ([see p. 3.8](#))
- Communications port correctly initialized (see PC communications card document)
- MicroDIN Address set and recorded ([see p. 2.7](#))
- MicroDIN baud rate set ([see p. 2.7](#))
- MicroDIN-compatible software ([see p. 2.9, A.2](#))
- MicroDIN correct order of parameter configuration ([see p. 2.8 or A.19 chart](#))
- Record all system parameters ([see p. 2.8 or A.19 chart](#))











MicroDIN Shutdown

Shutting down a Watlow MicroDIN-controlled thermal system for an optimum restart requires attention to the following list:

- Updating all systems and controllers parameter records.
- Securing any system safety interlocks or peripherals
- Protecting the system from unnecessary exposure to moisture or corrosive environments or dust
- Anticipating the next startup and associated issues.

Troubleshooting Alarms and Errors *most likely problems are listed first*

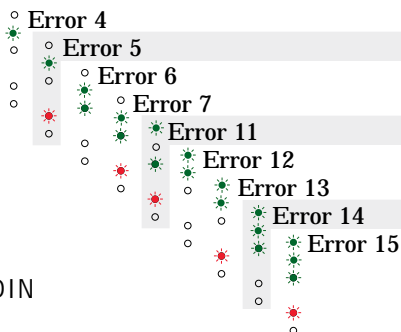
LED Indication	Symptoms	Probable Cause(s)
  <p>Error = off</p> <p>(Normal = steady green)</p>	<ul style="list-style-type: none"> No power. 	<p>Power</p> <ul style="list-style-type: none"> Power supply switch off Fuse blown Breaker tripped Safety interlock door switch, etc. Separate system limit control may be latched Open wiring Power ≤ 20V≈ (ac/dc)
  <p>Error = off</p> <p>(Normal = pulsing green)</p>	<ul style="list-style-type: none"> Unit will not communicate. 	<p>Communications</p> <ul style="list-style-type: none"> MicroDIN address DIP switch incorrectly set MicroDIN baud rate DIP switch incorrectly set MicroDIN unit-to-unit daisy chain disconnected Reversed, short or open EIA-485 communications wiring EIA-485 converter box incorrectly wired Computer COM port incorrectly set up Communications software setup or address incorrect Protocol or parity wrong, not 8, n, 1 Needs termination and pull-up and pull-down resistors
  <p>Error = steady red</p> <p>(Normal = off)</p>	<ul style="list-style-type: none"> Input is in error condition. 	<p>Input Error</p> <ul style="list-style-type: none"> The sensor is improperly wired Sensor wiring reversed, shorted or open MicroDIN firmware setting does not = actual sensor Power ≤ 20V≈ (ac/dc) Ambient environmental temperature out of spec for MicroDIN The MicroDIN open loop detect shows a broken sensor The calibration offset parameter is set much too high or low
  <p>Alarm = steady red</p> <p>(Normal = off)</p>	<ul style="list-style-type: none"> Alarm won't occur. Alarm won't clear. 	<p>Alarms</p> <ul style="list-style-type: none"> Alarm output off Alarm set points incorrect Alarm silenced Alarm sides incorrect In diagnostics mode Alarm latched Alarm set points incorrect Alarm hysteresis incorrect Input in error condition
<p>Flashing LED Indicator Light Pattern</p>		<p>Unit Errors</p> <ul style="list-style-type: none"> RAM malfunction EEPROM data corrupted PROM malfunction Logic hardware problem New firmware installed Calibration data corrupted Analog-to-digital hardware failure EEPROM hardware problem New unit first power up

Corrective Action	Reference
<ul style="list-style-type: none"> • Check switches, fuses, breakers, interlocks, limits, connectors, etc. for energized condition and proper connection • Measure power upstream for required level • Check wire size • Check for bad connections 	<ul style="list-style-type: none"> • See Watlow Publication #COR-AG-76, “Putting it All Together.” • See p. 3.7, 3.10, 3.11, A.14
<ul style="list-style-type: none"> • Check and reset unit DIP switches 1-6 to correct address • Check and reset unit DIP switch 8 to correct baud rate • Look for a break in the daisy chain • Verify correct connections and test wiring paths • Check converter box wiring and its documentation • Reconfigure computer's COM port setup and verify communications ok • Check the communication card documentation for setable variables, operational testing • Restart COMS software, check for settings agreement. Verify COM bus active 	<ul style="list-style-type: none"> • See p. 2.7 • See p. 2.7 • See p. 3.8 • See p. 3.8 • See p. 3.8 • See COM port information • See COM baud information • See software document
<ul style="list-style-type: none"> • Check sensor connections • Check sensor connections and sensor wiring • Change the Sensor Type parameter (Input Group) to match the sensor hardware • Measure power upstream for required level • Verify that the temperature surrounding unit is 32° to 149°F (0° to 65°C) • Check sensor function. The Open Loop Detect parameter (Error Group) indicates it may be broken • Check the Calibration Offset parameter (Input Group) value; set it to a lower level 	<ul style="list-style-type: none"> • See p. 3.5, 3.6, 3.7 • See p. 3.5, 3.6, 3.7 • See p. 5.5 • See p. 3.7, 3.10, 3.11, A.14 • See p. A.14 • See p. 5.22 • See p. 5.6
<ul style="list-style-type: none"> • Send the alarming MicroDIN unit a “clear alarm” signal (Modbus™: 331) Note: The condition causing the alarm must also be resolved for the alarm to clear • To clear the alarm, correct the alarm condition; check to see if the alarm is latched • Check the alarm sides setting • Check the alarm type setting • Check the alarm logic for compatibility with system peripherals and annunciators • Check the power limit setting • Check the operation mode • Check the alarm output function • Check °F/°C setting • Check the calibration offset value; set it to a lower level 	<ul style="list-style-type: none"> • See p. 5.17 • See p. 5.18, 5.19 • See p. 5.18 • See p. 5.20 • See p. 5.19 • See p. 5.21 • See p. 5.9 • See p. 5.18 • See p. 5.19 • See p. 5.3 • See p. 5.6
<ul style="list-style-type: none"> • Return unit to factory • Cycle power to unit • Return unit to factory • Return unit to factory • Cycle power to unit • Recalibrate unit • Return unit to factory • Return unit to factory • Return unit to factory 	<ul style="list-style-type: none"> • See back cover • See p. 3.10 - 3.11 • See back cover • See back cover • See p. 3.10 - 3.11 • See p. 6.6 • See back cover • See back cover • See back cover

Calibrating MicroDIN

Note: For information on writing Modbus™ RTU communications software for MicroDIN, see the Appendix.

To enter the calibration mode, first enter the diagnostics mode; send value 1789 to register 1512. Once in Diagnostics mode, to enter calibration mode, send 1415 to register 1600.

To restore factory calibrations settings, send value 1 to register 1601.

Thermocouple Input Procedure

Equipment Required

- Type J reference compensator with reference junction at 32°F / 0°C, or type J thermocouple calibrator set at 32°F / 0°C.
- Precision millivolt source, 0-50mV minimum range, 0.002mV resolution.

Setup and calibration

- 1) Connect voltage to MicroDIN Terminals 9, 10.

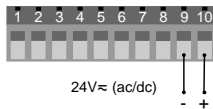

- 2) Connect the millivolt source to Terminal #1 (+) and Terminal #2 (-) on the MicroDIN with copper wire.

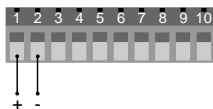

- 3) Enter 0.000mV from the millivolt source to the MicroDIN. Allow at least 10 seconds to stabilize.
 - Send value 1 to register 1603 to store 0.000mV input.
- 4) Enter 50.000mV from the millivolt source to the MicroDIN. Allow at least 10 seconds to stabilize.
 - Send value 2 to register 1603 to store 50.000mV input.
- 5) Disconnect the millivolt source and connect the reference compensator or T/C calibrator to terminal #1 (+) and Terminal #2 (-). With Type J t/c wire, if using a compensator, turn it on and short the input wires. When using a Type J calibrator, set it to simulate 32°F / 0°C. Allow 10 seconds for the control to stabilize.
 - Send register 1603 value 3 to store CJC input (32°F, type J, compensated).
- 6) Rewire for operation and verify calibration.

RTD Input Procedure

Equipment Required

- 1KΩ precision decade box with 0.01Ω resolution
- Precision current source, 0-4mA range with 0.01mA resolution

Setup and calibration

- 1) Connect voltage to terminals #9, #10.

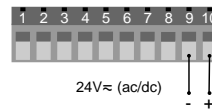

- 2) Short terminals 1, 2 and 3 together with less than 0.1Ω.
 - Send register 1603 value 4 to store ground input.

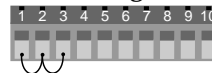

- 3) Short terminals 1 and 3 together with less than 0.5Ω.

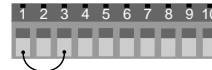

- Send register 1603 value 5 to store RTD lead resistance.

- 4) Connect the decade box to terminals #1, #2 and #3 on the MicroDIN. Use 20 to 24 gauge copper wire.

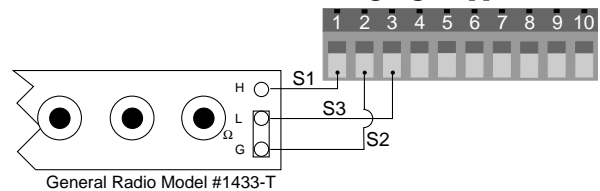

- 5) Enter 15.00Ω from the decade box to the MicroDIN. Allow at least 10 seconds to stabilize.
 - Send value 6 to register 1603 to store 15.00Ω.
- 6) Enter 380.00Ω from the decade box to the MicroDIN. Allow at least 10 seconds to stabilize.
 - Send register 1603 value 7 to store 380.00Ω.
- 7) Disconnect the decade box, and connect the current source to Terminals #2 (-) and #3 (+).
- 8) Enter 4.00mA from the current source to the MicroDIN. Allow at least 10 seconds to stabilize.
 - Send value 10 to register 1603 to store 4mA input.
- 9) Rewire for operation and verify calibration.

A

Appendix

Modbus™ RTU	A.2
Glossary	A.8
Declaration of Conformity	A.12
Specifications	A.13
Ordering Information	A.15
Index	A.16
Parameter Index	A.18
Required Parameter Setup Order	A.19
Warranty Information	Back Cover

Modbus Remote Terminal Unit (RTU)

Modbus RTU enables a computer or PLC to read and write directly to registers containing the controller's parameters. With it you could read all 141 of the controller's parameters with five read commands.

Because of the wide array of choices available for setting up a MicroDIN controller, only a subset of the prompts contain parameters in a given situation. This manual explains the interrelations between prompts. A Modbus read command response of -32000 indicates that a register is not implemented; -32001, register not active; or -32002, not read accessible. A write command will return an exception response of 01 to indicate an illegal function, 02, illegal register; or 03, illegal data. If you try to write to an inactive prompt the controller will return an illegal data address message (02).

If you already have a software application that uses Modbus, you can simply skip to the Temperature/process Controller Prompt Table or the Modbus RTU Address Table in this chapter for the address information your program will need. The rest of this section on the Modbus provides information for writing a software application that uses Modbus.

Writing a Modbus Application

You need to code messages in eight-bit bytes, with no parity bit, one stop bit (8, n, 1). Negative parameter values must be written in twos complement format. Parameters are stored in two-byte registers accessed with read and write commands to a relative address.

Messages are sent in packets that are delimited by a pause at least as long as the time it takes to send 30 bits. To determine this time in seconds, divide 30 by your baud rate.

Because changing some parameters automatically changes or defaults other parameters, use the Complete Parameter Download Sequence table in this chapter to order write commands.

Using a controller address of 0x00 for a write command broadcasts that command to all the controllers in the network. This is a powerful feature if all the controllers on a network use all or most of the same parameters.

Packet Syntax

Each message packet begins with a one-byte controller address, from 0x01 to 0xF7. The second byte in the message packet identifies the message command: read (0x03 or 0x04); write (0x06 or 0x10); or loop back (0x08).

The next n bytes of the message packet contain register addresses and/or data.

The last two bytes in the message packet contain a two-byte Cyclical Redundancy Checksum (CRC) for error detection.

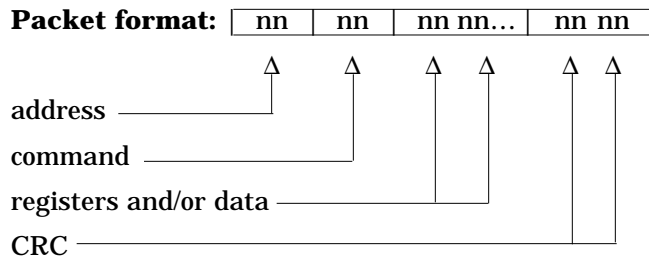

Read Multiple Registers Command (0x03 or 0x04)

This command returns from 1 to 32 registers.

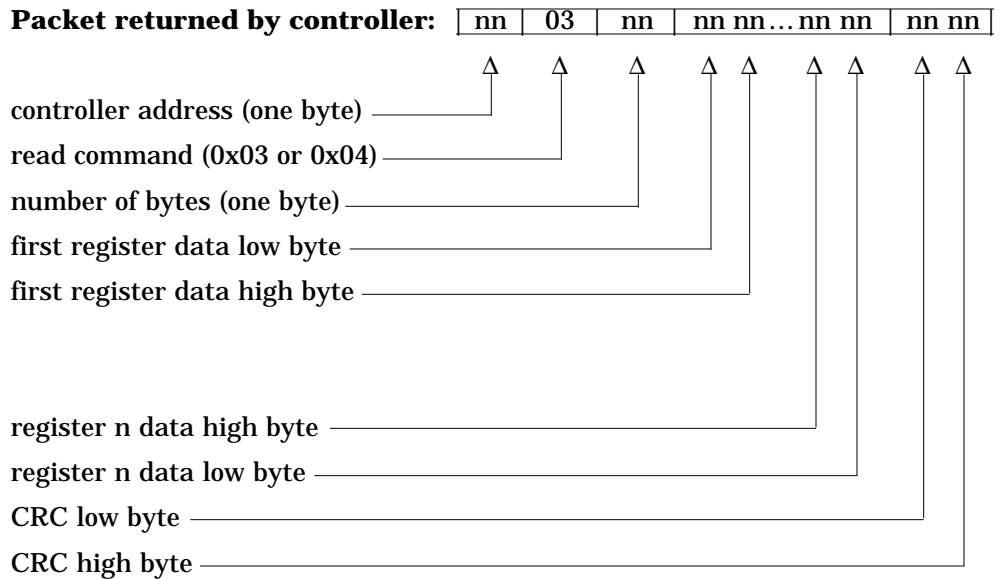
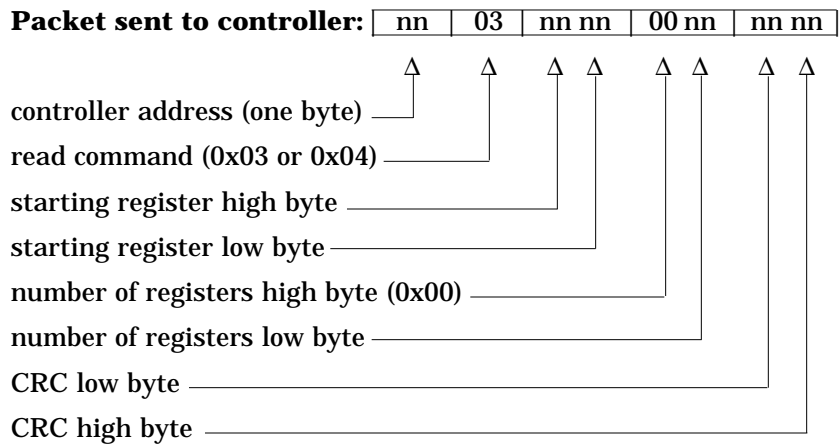

Example: Read register 0 (model number) of the controller at address 1.

Sent: 01 03 00 00 00 01 84 0A
Received: 01 03 02 03 DC B9 2D
Message: 988 (0x03DC).

Example: Read register 1 and 2 (Process 1 and 2 values) of controller at address 5.

Sent: 05 03 00 01 00 02 94 4F
Received: 05 03 04 00 64 00 C8 FF BA
Message: 100 (0x0064) and 200 (0x00C8).

Write to a Single Register Command (0x06)

This command writes a parameter to a single register. The controller will echo back the command. An attempt to write to a read-only parameter returns an illegal data address error (0x02).

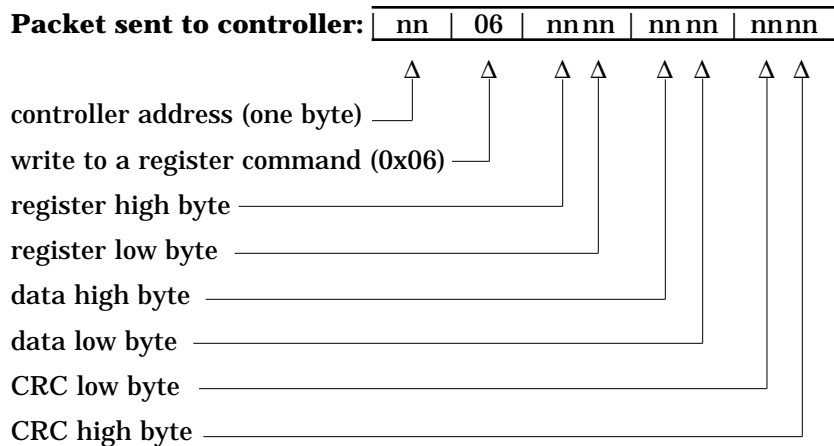

Example: Set register 7 (SPI) to 200 (0x00C8) on controller at address 9.

Sent: 09 06 00 07 00 C8 38 D5
Received: 09 06 00 07 00 C8 38 D5

Write to Multiple Registers Command (0x10)

This command actually writes a parameter to only a single register. An attempt to write to a read-only parameter returns an illegal data address error (0x02).

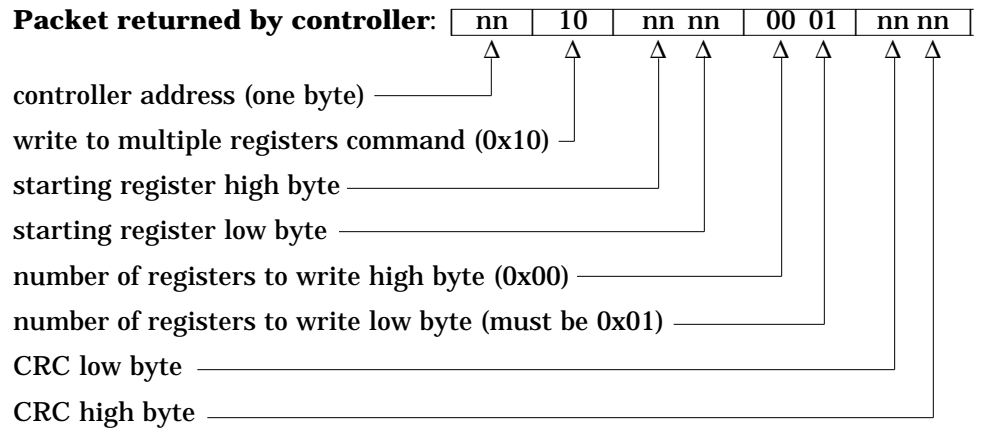
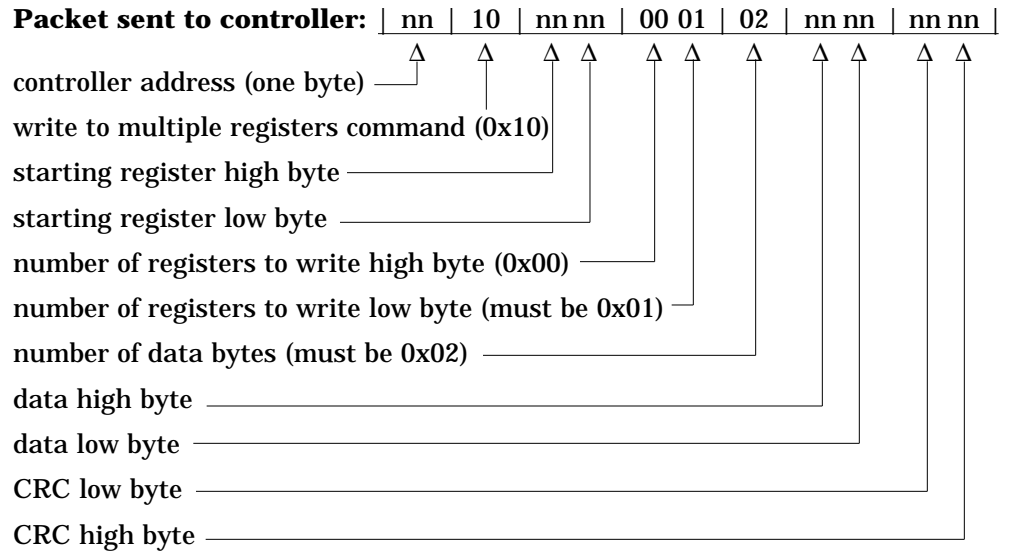

Loop Back Command (0x08)

This command simply echoes the message. This serves as a quick way to check your wiring.

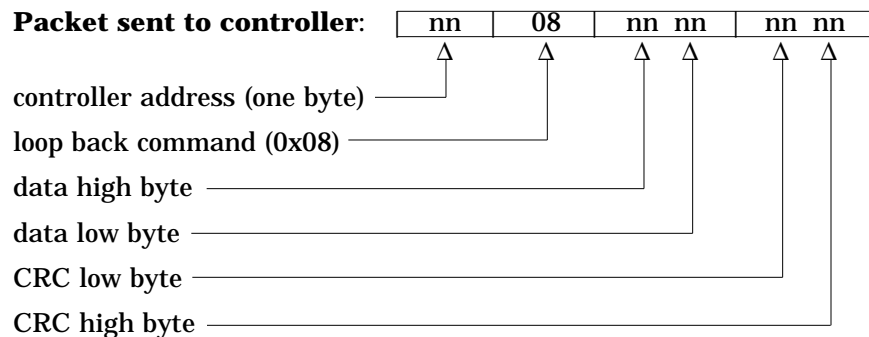

Example: Run loop back test on controller at address 40 (0x28).

Sent: 28 08 55 66 77 88 31 B7

Received: 28 08 55 66 77 88 31 B7

Exception Responses

When a controller cannot process a command it returns an exception response and sets the high bit (0x80) of the command.

0x01 illegal command

0x02 illegal data address

0x03 illegal data value

Packet returned by controller:

nn	nn	nn	nn	nn
----	----	----	----	----

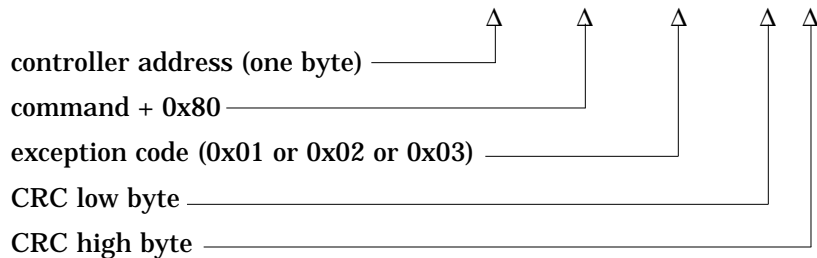

Messages with the wrong format, timing or CRC are ignored. A read command sent to an inactive parameter returns 0x0000.

Example: Exception 01 - Command 02 is not supported.

Sent: 01 02 00 01 00 02 A8 0B

Received: 01 82 01 81 60

Example: Exception 02 - The parameter at register 45 (0x002D) is inactive.

Sent: 01 06 00 2D 00 01 D8 C3

Received: 01 86 02 C3 A1

Example: Exception 03 - Cannot write 12,000 (0x2EE0) to register 7, out of range, illegal data value.

Sent: 01 06 00 07 2E E0 24 23

Received: 01 86 03 02 61

Cyclical Redundancy Checksum (CRC) Algorithm

This C routine, `calc_crc()`, calculates the cyclical redundancy checksum, CRC, for a string of characters. The CRC is the result of dividing the string by 0xA001. Modbus applications calculate the packet's CRC then append it to the packet.

```
#define POLYNOMIAL 0xA001;

unsigned int calc_crc(unsigned char *start_of_packet, unsigned char
*end_of_packet)
{
    unsigned int crc;
    unsigned char bit_count;
    unsigned char *char_ptr;

    /* Start at the beginning of the packet */
    char_ptr = start_of_packet;

    /* Initialize CRC */
    crc = 0xffff;

    /* Loop through the entire packet */
    do{
        /* Exclusive-OR the byte with the CRC */
        crc ^= (unsigned int)*char_ptr;

        /* Loop through all 8 data bits */
        bit_count = 0;
        do{
            /* If the LSB is 1, shift the CRC and XOR the polynomial mask with the CRC */
            if(crc & 0x0001){
                crc >>= 1;
                crc ^= POLYNOMIAL;
            }

            /* If the LSB is 0, shift the CRC only */
            else{
                crc >>= 1;
            }
        } while(bit_count++ < 7);
        } while(char_ptr++ < end_of_packet);

    return(crc);
}
```

Glossary

annunciator — A visual display that uses pilot lights to indicate the former or existing condition of several items in a system.

burst fire — A power control method that repeatedly turns on and off full ac cycles. Also called zero-cross fire, it switches close to the zero-voltage point of the ac sine wave. Variable-time-base burst fire selectively holds or transits ac cycles to achieve the desired power level. See zero cross.

calibration offset — An adjustment to eliminate the difference between the indicated value and the actual process value.

CJC — see cold junction compensation.

closed loop — A control system that uses a sensor to measure a process variable and makes decisions based on that feedback.

cold junction — see junction, cold.

cold junction compensation — Electronic means to compensate for the effective temperature at the cold junction.

default parameters — The programmed instructions that are permanently stored in the microprocessor software.

derivative — The rate of change in a process variable. Also known as rate. See PID.

derivative control (D) — The last term in the PID control algorithm. Action that anticipates the rate of change of the process, and compensates to minimize overshoot and undershoot. Derivative control is an instantaneous change of the control output in the same direction as the proportional error. This is caused by a change in the process variable (PV) that decreases over the time of the derivative (TD). The TD is in units of seconds.

Deutsche Industrial Norm (DIN) — A set of technical, scientific and dimensional standards developed in Germany. Many DIN standards have worldwide recognition.

DIN — See Deutsche Industrial Norm.

droop — In proportional controllers, the difference between set point and actual value after the system stabilizes.

duty cycle — The percentage of a cycle time in which the output is on.

external transmitter power supply — A dc voltage source that powers external devices.

filter, digital (DF) — A filter that slows the response of a system when inputs change unrealistically or too fast. Equivalent to a standard resistor-capacitor (RC) filter.

form A — A single-pole, single-throw relay that uses only the normally open (NO) and common contacts. These contacts close when the relay coil is energized. They open when power is removed from the coil.

form B — A single-pole, single-throw relay that uses only the normally closed (NC) and common contacts. These contacts open when the relay coil is energized. They close when power is removed from the coil.

form C — A single-pole, double-throw relay that uses the normally open (NO), normally closed (NC) and common contacts. The operator can choose to wire for

a form A or form B contact.

hysteresis — A change in the process variable required to re-energize the control or alarm output. Sometimes called switching differential.

integral — Control action that automatically eliminates offset, or droop, between set point and actual process temperature. See auto-reset.

integral control (I) — A form of temperature control. The I of PID. See integral.

isolation — Electrical separation of sensor from high voltage circuitry. Allows use of grounded or ungrounded sensing element.

JIS — See Joint Industrial Standards.

junction, cold — Connection point between thermocouple metals and the electronic instrument. See junction, reference.

junction, reference — The junction in a thermocouple circuit held at a stable, known temperature (cold junction). Standard reference temperature is 32°F (0°C).

Modbus™ — A digital communications protocol owned by AEG Schneider Automation for industrial computer networks.

Modbus™ RTU — Remote Terminal Unit, an individual Modbus™-capable device on a network.

NEMA 4X — A NEMA specification for determining resistance to moisture infiltration. This rating certifies the controller as washable and corrosion resistant.

on/off controller — A temperature controller that operates in either full on or full off modes.

open loop — A control system with no sensory feedback.

output — Control signal action in response to the difference between set point and process variable.

overshoot — The amount by which a process variable exceeds the set point before it stabilizes.

P control — Proportioning control.

PD control — Proportioning control with derivative (rate) action.

PDR control — Proportional derivative control with manual reset, used in fast responding systems where the reset causes instabilities. With PDR control, an operator can enter a manual reset value that eliminates droop in the system.

PI control — Proportioning control with integral (auto-reset) action.

PID — Proportional, integral, derivative. A control mode with three functions: proportional action dampens the system response, integral corrects for droop, and derivative prevents overshoot and undershoot.

proportional — Output effort proportional to the error from set point. For example, if the proportional band is 20° and the process is 10° below set point, the heat proportioned effort is 50 percent. The lower the PB value, the higher the gain.

proportional band (PB) — A range in which the proportioning function of the control is active. Expressed in units, degrees or percent of span. See PID.

proportional control — A control using only the P (proportional) value of PID control.

range — The area between two limits in which a quantity or value is measured. It is usually described in terms of lower and upper limits.

rate — Anticipatory action that is based on the rate of temperature change, and compensates to minimize overshoot and undershoot. See derivative.

rate band — A range in which the rate function of a controller is active. Expressed in multiples of the proportional band. See PID.

reference junction — see junction, reference.

remote — A controller that receives its set point signal from another device called the master.

remote set point — A signal that indicates the set point for the process, and is sent from another device.

reset — Control action that automatically eliminates offset, or droop, between set point and actual process temperature. Also see integral.

automatic reset — The integral function of a PI or PID temperature controller that adjusts the process temperature to the set point after the system stabilizes. The inverse of integral.

automatic power reset — A feature in latching limit controls that does not recognize power outage as a limit condition. When power is restored, the output is re-energized automatically, as long as the temperature is within limits.

manual reset — 1) A feature on a limit control that requires human intervention to return the limit to normal operation after a limit condition has occurred. 2) The adjustment of a proportional control to raise the proportional band to compensate for droop.

resistance temperature detector (RTD) — A sensor that uses the resistance temperature characteristic to measure temperature. There are two basic types of RTDs: the wire RTD, which is usually made of platinum, and the thermistor, which is made of a semiconductor material. The wire RTD is a positive temperature coefficient sensor only, while the thermistor can have either a negative or positive temperature coefficient.

RTD — See resistance temperature detector.

thermal system — A regulated environment that consists of a heat source, heat transfer medium or load, sensing device and a control instrument.

thermocouple (t/c) — A temperature sensing device made by joining two dissimilar metals. This junction produces an electrical voltage in proportion to the difference in temperature between the hot junction (sensing junction) and the lead wire connection to the instrument (cold junction).

thermocouple break protection — The ability of a control to detect a break in the thermocouple circuit and take a predetermined action.

three-mode control — Proportioning control with integral (reset) and derivative (rate). Also see PID.

time proportioning control — A method of controlling power by varying the on/off duty cycle of an output. This variance is proportional to the difference between the set point and the actual process temperature.

transmitter — A device that transmits temperature data from either a thermocouple or a resistance temperature detector (RTD) by way of a two-wire loop. The loop has an external power supply. The transmitter acts as a variable resistor with respect to its input signal. Transmitters are desirable when long lead or extension wires produce unacceptable signal degradation.

WatLink — A Watlow software application for configuring and communication with Watlow controllers via a EIA-485 network and a Microsoft Windows-compatible personal computer.

zero cross — Action that provides output switching only at or near the zero-voltage crossing points of the ac sine wave. See burst fire.

zero switching — See zero cross.

Declaration of Conformity

WATLOW CONTROLS
1241 Bundy Boulevard
Winona, Minnesota 55987 USA



Series MicroDIN

Declares that the following product: **English**

Designation: Series MicroDIN
Model Number(s): UD 1 A -1CES - (Any four numbers or letters)
Classification: Control, Installation Category II, Pollution Degree II
Rated Voltage: 24 to 28V \approx (ac/dc)
Rated Frequency: 50/60 Hz
Rated Power Consumption: 5VA maximum

Meets the essential requirements of the following European Union Directive(s) using the relevant section(s) of the normalized standards and related documents shown:

89/336/EEC Electromagnetic Compatibility Directive

EN 50082-2: 1995 EMC Generic immunity standard, Part 2: Industrial environment

EN 61000-4-2: 1995 Electrostatic discharge
EN 61000-4-4: 1995 Electrical fast transients
ENV 50140: 1994 Radiated immunity
ENV 50141: 1994 Conducted immunity
ENV 50204: 1995 Cellular phone

EN 50081-2: 1994 EMC Generic emission standard, Part 2: Industrial environment

EN 55011: 1991 Limits and methods of measurement of radio disturbance characteristics of industrial, scientific and medical radio-frequency equipment (Class A)

73/23/EEC Low-Voltage Directive

EN 61010-1: 1993 Safety requirements for electrical equipment for measurement, control, and laboratory use, Part 1: General requirements

Déclare que le produit suivant : **Français**

Désignation : Série MicroDIN
Numéro(s) de modèle(s) : UD 1 A - 1CES - (quatre chiffres ou lettres quelconques)
Classification : Commande, installation catégorie II, degré de pollution II
Tension nominale : 24 à 28 V \approx (c.a./c.c.)
Fréquence nominale : 50/60 Hz
Consommation d'alimentation nominale : 5 VA maximum

Conforme aux exigences de la (ou des) directive(s) suivante(s) de l'Union Européenne figurant aux sections correspondantes des normes et documents associés ci-dessous :

89/336/EEC Directive de compatibilité électromagnétique

EN 50082-2: 1995 Norme générique d'insensibilité électromagnétique, Partie 2 : Environnement industriel

EN 61000-4-2: 1995 Décharge électrostatique
EN 61000-4-4: 1995 Courants électriques transitoires rapides
ENV 50140: 1994 Insensibilité à l'énergie rayonnée
ENV 50141: 1994 Insensibilité à l'énergie par conduction
ENV 50204: 1995 Téléphone cellulaire

EN 50081-2: 1994 Norme générique sur les émissions électromagnétiques, Partie 2 : Environnement industriel

EN 55011: 1991 Limites et méthodes de mesure des caractéristiques d'interférences du matériel radiofréquence industriel, scientifique et médical (Classe A)

73/23/EEC Directive liée aux basses tensions

EN 61010-1: 1993 Exigences de sécurité pour le matériel électrique de mesure, de commande et de laboratoire, Partie 1 : Exigences générales

Erklärt, daß das folgende Produkt: **Deutsch**

Beschreibung: Serie MicroDIN
Modellnummer(n): UD 1 A - 1 CES - (4 beliebige Zahlen oder Buchstaben)
Klassifikation: Regelsystem, Installationskategorie II, Emissionsgrad II
Nennspannung: 24 bis 28 V \approx (ac/dc)
Nennfrequenz: 50/60 Hz
Nominaler Stromverbrauch: Max. 5 VA

Erfüllt die wichtigsten Normen der folgenden Anweisung(en) der Europäischen Union unter Verwendung des wichtigsten Abschnitts bzw. der wichtigsten Abschnitte der normalisierten Spezifikationen und der untenstehenden einschlägigen Dokumente:

89/336/EEC EWG Elektromagnetische Verträglichkeit

EN 50082-2: 1995 EMC-Rahmennorm für Störsicherheit, Teil 2: Industrielle Umwelt

EN 61000-4-2: 1995 Elektrostatische Entladung
EN 61000-4-4: 1995 Elektrische schnelle Stöße
ENV 50140: 1994 Strahlungsimmunität
ENV 50141: 1994 Leitungsimmunität
ENV 50204: 1995 Mobiltelefon

EN 50081-2: 1994 EMC-Rahmennorm für Emissionen, Teil 2: Industrielle Umwelt

EN 55011: 1991 Beschränkungen und Methoden der Messung von Funkstörungsmerkmalen industrieller, wissenschaftlicher und medizinischer Hochfrequenzgeräte (Klasse A)

72/23/EEC EWG Niederspannungsrichtlinie

EN 61010-1: 1993 Sicherheitsrichtlinien für Elektrogeräte zur Messung, zur Steuerung und im Labor, Teil 1: Allgemeine Richtlinien

Declara que el producto siguiente: **Español**

Designación: Serie MicroDIN
Números de modelo: UD 1 A - 1CES - (Cualquier combinación de cuatro números y letras)
Clasificación: Control, categoría de instalación II, grado de contaminación ambiental II
Tensión nominal: 24 a 28V \approx (Vca/Vcc)
Frecuencia nominal: 50/60 Hz
Consumo nominal de energía: 5 VA máximo

Cumple con los requisitos esenciales de las siguientes directivas de la Unión Europea, usando las secciones pertinentes de las reglas normalizadas y los documentos relacionados que se muestran:

89/336/EEC Directiva de compatibilidad electromagnética

EN 50082-2: 1995 Norma de inmunidad genérica del EMC, parte 2: Ambiente industrial

EN 61000-4-2: 1995 Descarga electrostática
EN 61000-4-4: 1995 Perturbaciones transitorias eléctricas rápidas
ENV 50140: 1994 Inmunidad radiada
ENV 50141: 1994 Inmunidad conducida
ENV 50204: 1995 Teléfono portátil

EN 50081-2: 1994 Norma de emisión genérica del EMC, parte 2: Ambiente industrial

EN 55011: 1991 Límites y métodos de medición de características de perturbaciones de radio correspondientes a equipos de radiofrecuencia industriales, científicos y médicos (Clase A)

73/23/EEC Directiva de baja tensión

EN 61010-1: 1993 Requerimientos de seguridad para equipos eléctricos de medición, control y uso en laboratorios, Parte 1: Requerimientos generales

Erwin D. Lowell Winona, Minnesota, USA
Name of Authorized Representative Place of Issue

General Manager February 1, 1997
Title of Authorized Representative Date of Issue

Signature of Authorized Representative

Specifications:

W0UD-XSPN Rev A01

Control Mode

- Microprocessor-based, user selectable control modes
- Single input, single output
- Heat or cool auto-tuning

Output #1: User selectable

- ON/OFF; P, PI, PD, PID heat or cool action adjustable switching differential: 1 to 9999 or 0.1 to 999.9°F or °C
- Proportional band: 0 to 9999, or 0.0 to 999.9°F or °C
- Integral: 0.00 to 99.99 minutes per repeat
- Reset: 0.00 to 99.99 repeats per minute
- Derivative/Rate: 0.00 to 9.99 minutes
- Cycle Time: 0.1 to 60.0 seconds

Output #2: User selectable

- Process or deviation alarm with flashing alarm status indicator
- Alarm with separate high and low set points
- Hysteresis: 1 to 9999° switching differential

Operator Interface

- EIA-485 serial communications with Modbus™ RTU protocol
- 9600, 19200 user selectable baud rates
- 1 to 63 user selectable address range

Sensor Input

- Sensor input sampling rate: 10 samples/second, 10Hz
- Thermocouple, grounded or ungrounded sensors
- RTD 2 or 3 wire, platinum, 100Ω@ 0°C calibration to JIS curve (0.003916Ω/Ω/°C), or DIN curve (0.00385Ω/Ω/°C)
- Sensor break protection de-energizes control output to protect system or selectable bumpless transfer to manual operation.
- °F or °C, user selectable
- Sensor Ranges:

	Accuracy Ranges:			Operating Ranges		
B t/c	1598 to 3092°F	870 to 1700°C	32 to 3300°F	0 to 1816°C		
C (W5) t/c	32 to 4200°F	0 to 2315°C	32 to 4200°F	0 to 2315°C		
D (W3) t/c	32 to 4200°F	0 to 2315°C	32 to 4200°F	0 to 2315°C		
E t/c	-328 to 1472°F	-200 to 800°C	-328 to 1470°F	-200 to 800°C		
J t/c	32 to 1382°F	0 to 750°C	32 to 1500°F	0 to 815°C		
K t/c	-328 to 2282°F	-200 to 1250°C	-328 to 2500°F	-200 to 1370°C		
N t/c	32 to 2282°F	0 to 1250°C	32 to 2372°F	0 to 1300°C		
PT2 t/c	32 to 2540°F	0 to 1393°C	32 to 2543°F	0 to 1395°C		
R t/c	32 to 2642°F	0 to 1450°C	32 to 3200°F	0 to 1760°C		
S t/c	32 to 2642°F	0 to 1450°C	32 to 3200°F	0 to 1760°C		
T t/c	-328 to 662°F	-200 to 350°C	-328 to 750°F	-200 to 400°C		
1.0 RTD (DIN)	-328 to 1202°F	-200 to 650°C	-328 to 1472°F	-200 to 800°C		
0.1 RTD (JIS)	-199.9 to 999.9°F	-143 to 636°C	-328 to 1166°F	-200 to 630°C		

- Tenth degree resolution selectable over sensor operating range within limits of -199.9 to 999.9, except for thermocouple types B, R, and S

Primary Control Output (heating or cooling)

- Output update rate: 10 per second, 10Hz (maximum)
Internal Load Switching (nominal):
Switched dc (isolated) signal, 22 to 28V \approx (Vdc), current limited @ 30mA
Overload current and short circuit protection
External Load Switching (maximum):
- Open Collector 60V \approx (Vdc) @ 1A

Alarm Output

- Output update rate 2 per second (2Hz)
- Electromechanical relay, Form A, 2A @ 30V \approx (Vdc) or 240V \sim (Vac),
- Alarm output can be latching or non-latching, and process or deviation with separate high and low values. Alarm silencing (inhibit) on power-up.

Accuracy

- Calibration accuracy and sensor conformity: $\pm 0.1\%$ of span ± 1 @ 77°F ± 5 °F (25°C ± 3 °C) ambient, and rated line voltage $\pm 10\%$ with the following exceptions:
Type T; 0.12% of span for -200°C to -50°C
Types R and S; 0.15% of span for 0°C to 100°C
Type B; 0.24% of span for 870°C to 1700°C
- Accuracy span: Less than or equal to operating ranges, 1000°F/540°C minimum.
- Temperature stability: ± 0.2 °F/°F (± 0.2 °C/°C) rise in ambient maximum for thermocouples, ± 0.05 °F/°F (± 0.05 °C/°C) rise in ambient maximum for RTD sensors
- Voltage stability: $\pm 0.01\%$ of span per percent of rated line voltage

Safety Agency Approvals

- UL/C-UL 508, File # E102269
Industrial Control Equipment
- CE to EN 61010 (pending)

Electromagnetic Compatibility and Immunity

- Complies with EN 50081, EN 50082

Terminals

- Touch-safe set screw type, accepts 26 to 14 gauge wire

Power

- 24-28V \approx (Vac/Vdc), -15%, +10% [20.4 to 30.8V \approx (Vac/Vdc)]; 50/60Hz $\pm 5\%$ for V \sim (Vac)
- 5VA typical power consumption
- Data retention upon power failure via nonvolatile memory
- Sensor input isolation to switched dc output and communication circuitry
500V \sim (Vac) dielectric

Operating Environment

- 32 to 149°F (0 to 65°C)
- 0 to 90% RH, non-condensing
- Storage temperature: -40 to 158°F (-40 to 70°C)

Dimensions

- Width x Height x Depth
1.64" x 4.65" x 5.19" DIN rail mount
(42mm x 118mm x 132mm)
1.64" x 4.65" x 5.06" Chassis mount
(42mm x 118mm 129mm)
- Mounts on DIN rail per DIN EN 50022 (35mm x 7.5mm)
UL \circ is a registered trademark of Underwriters Laboratories.
Modbus ™ is a registered trademark of AEG Schneider Automation.
Adobe \circ and Acrobat \circ are registered trademarks of Adobe Systems Incorporated.
These specifications are subject to change without prior notice.

Ordering Information

MicroDIN Controller -
W0UD-XMNN Rev A00

DIN Rail Mount
Temperature Controller
with no operator
interface and EIA-485
Modbus™ RTU Serial
Communications.

To order, complete the code number to the right with the information below:

U D 1 A - 1 C E S -

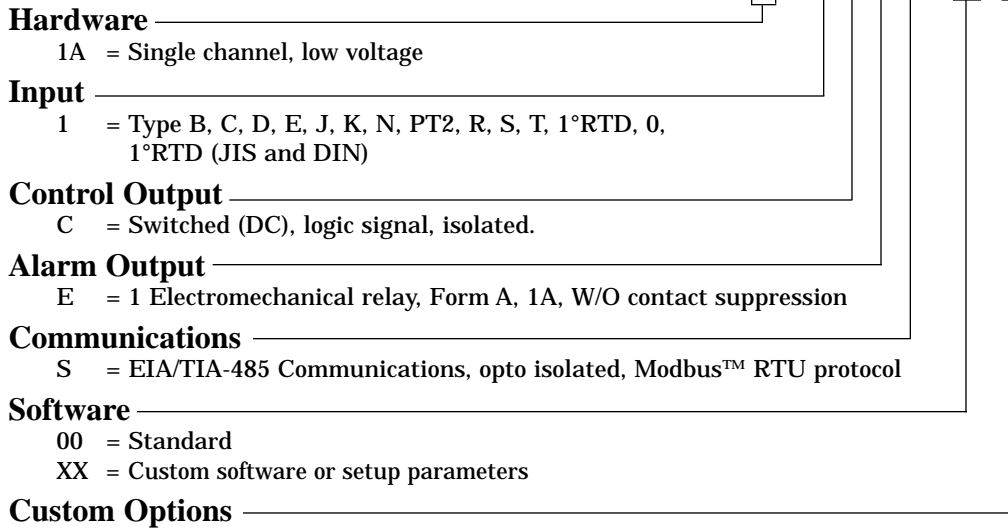

¹Electromechanical relays are warranted for 100,000 closures only.

- Custom Options**
 - 00 = None
 - AA = No Watlow logo on front bezel
 - AB = French nomenclature on front bezel
 - AC = German nomenclature on front bezel
 - AD = Spanish nomenclature on front bezel
 - XX = Custom bezel or label

Configurator software and manual.
Provides operator interface using EIA/TIA-485
Modbus RTU Serial Communications. **W L N K - M D B S - 0 0 0 0**

MicroDIN User's Manual paper version, 8.5" x 11",
5-hole, 104 pages **W O U D - X U M N**

MicroDIN User's Manual Adobe Acrobat®
version on 3.5" diskette (Windows) **W O U D - X U M N - D I S K**

MicroDIN Starter Kit includes configurator
software and manual, power supply, and
communications cable (RJ11 to 4 pigtail leads). **U D 1 A - S T R T - M R T U**

MicroDIN Developers Kit includes MicroDIN
Controller, MicroDIN Starter Kit, EIA-232 to
EIA-485 converter module, DIN-a-mite power
controller with test load, and DIN rail for
convenient mounting. **U D 1 A - D E V K - M R T U**

6-inch communications cable (RJ-11, 4 conductor,
straight through) **0 2 1 9 - 0 2 1 8 - 0 0 0 0**

7-foot communications cable (RJ-11, 4 conductor,
straight through) **0 2 1 9 - 0 2 1 7 - 0 0 0 0**

10-pin removable connector with screw terminals
Communications converter (EIA-232 to EIA-485) **0 8 3 6 - 0 4 4 5 - 0 0 0 0**

Power Supply 120V~ (Vac) input, 24V= (Vdc) output **0 8 3 0 - 0 4 7 3 - 0 0 0 0**

Power Supply 120V~ (Vac) input, 24V= (Vdc) output **0 8 3 0 - 0 4 7 4 - 0 0 0 0**

MicroDIN Accessories

Index

10-pin connector [3.5](#)

A

accuracy [A.14](#)
affects table [2.8](#)
Alarm Active Sides [5.20](#)
Alarm Condition [5.17](#)
Alarm High [5.19](#)
Alarm Hysteresis [4.11, 5.20](#)
alarm latching [4.12](#)
Alarm Latching Mode [5.20 - 5.21](#)
Alarm Logic [5.21](#)
Alarm Low [5.18 - 5.19](#)
alarm output [A.14](#)
Alarm Output Function [5.19](#)
Alarm Output Group [5.17 - 5.21](#)
Alarm Output Hardware [5.17 - 5.18](#)
alarms [4.11 - 4.13](#)
alarm set points [4.11](#)
alarm silencing [4.13](#)
Alarm Silencing Mode [5.21](#)
Alarm Type [5.19 - 5.20](#)
Ambient Temperature [5.2](#)
Analog-to-digital Counts [5.27 - 5.28](#)
Appendix [A.1 - A.19](#)
auto-tune [4.2](#)
Auto-tune Set Point [5.13](#)

B

baud rates [2.7](#)
Bumpless Transfer [4.15](#)

C

Calibration Commands [5.30](#)
Calibration Group [5.30 - 5.31](#)
Calibration Mode [5.30](#)
Calibration Procedures [6.6](#)
Calibration Offset [4.4, 5.6](#)
Characteristics Group [5.25 - 5.26](#)
CJC Counts [5.27](#)
Clear Alarm [5.18](#)
Clear Error [5.23](#)
communications [2.2](#)
communications interface [2.5](#)
communications wiring [3.8 - 3.10](#)
control methods [4.7 - 4.10](#)
control mode [A.13](#)
Control Output Function [5.8 - 5.9](#)
Control Output Group [5.8 - 5.10](#)
Control Output Hardware [5.8](#)
C or F [5.3](#)

Cycle Time [5.15 - 5.16](#)
cyclical redundancy checksum [A.7](#)

D

Date of Manufacture [5.25](#)
Decimal Point [5.3](#)
Declaration of Conformity [A.12](#)
Derivative [5.15](#)
deviation alarms [4.12](#)
Diagnostics Group [5.27 - 5.29](#)
Diagnostics Mode [5.29](#)
dimensions [A.14](#)
DIP switches [2.7](#)
Disable Non-volatile Memory [5.2](#)
dismounting [3.4](#)

E

EIA-485 [2.3](#)
electromagnetic compatibility and immunity [A.14](#)
Enter Calibration Mode [5.30](#)
Enter Diagnostics Mode [5.29](#)
Error Clearing Mode [5.24](#)
Error Group [5.22 - 5.24](#)
errors [4.14](#)
exception responses [A.6](#)

F

Factory Calibration [5.30 - 5.31](#)
Filter Time Constant [4.5, 5.7](#)
Fixed Manual Output [5.10](#)

H

High Side Power [5.9](#)

G

Glossary [A.8 - A.11](#)

I

Initiate Auto-tune [5.17](#)
input [4.4 - 4.6](#)
Input Actual [5.4](#)
Input Counts [5.27](#)
Input Error [5.4, 5.23 - 5.24](#)
Input Error Action [5.7, 5.22 - 5.23](#)
Input Group [5.4 - 5.7](#)
Input Type [5.5](#)
input wiring [3.6](#)
installation [3.1 - 3.12](#)
Integral [5.14](#)

internal load switching [A.13 - A.14](#)
introduction [1.2](#)

L

lights [1.3](#)
loop back command [A.5 - A.6](#)
Low Side Power [5.9 - 5.10](#)

M

Manual Output Power [5.12](#)
Modbus™ register numbers [2.6](#)
Modbus™ remote terminal unit [2.5, A.2](#)
Model Number [5.27](#)
mounting [3.1 - 3.4](#)
multiple registers command [A.3 - A.4](#)

N

Non-volatile Memory [5.2](#)

O

on/off control [4.7](#)
Open Loop Detect [4.14, 5.22](#)
Open Loop Error [5.22](#)
operating environment [A.14](#)
operation interface [A.13 - A.14](#)
Operation Mode [5.11](#)
operations [6.1 - 6.6](#)
operator interface [A.13 - A.14](#)
ordering information [A.15](#)
Output Hysteresis [5.16](#)
Output Power [5.13](#)
overview [1.1 - 1.4](#)

P

packet syntax [A.3](#)
panel indicator lights [4.14](#)
parameter setup order [A.19](#)
parts list [3.2](#)
PID group [5.13 - 5.16](#)
PID Output Power [5.13](#)
power [A.14](#)
power limit [4.3](#)
Power Limit Set Point [5.9](#)
primary control output [A.14](#)
process alarms [4.12](#)
programmable logic controller [4.2, 5.15](#)
Propband [5.14](#)

proportional control [4.8](#)
proportional integral control [4.9](#)
proportional integral derivative control [4.10](#)

R

Range High [4.6](#), [5.6](#)
Range Low [4.6](#), [5.6](#)
Rate [5.15](#)
Reset [5.15](#)
Restore Factory Calibration [5.30](#) - [5.31](#)
Restore Factory Defaults [5.31](#)
RTD lead compensation [5.28](#)
RTD lead resistance [5.28](#)

S

safety agency approvals [A.14](#)
safety information [1](#)
sensor input [A.13](#)
sensor selection [4.6](#)
Sensor Type [5.5](#)
serial interface [2.9](#)
Serial Number 1 [5.25](#)
Serial Number 2 [5.26](#)
Set Point [5.12](#)
setup steps [1.3](#)
Ship Date [5.25](#)
shutdown [6.3](#)
Silence Alarm [5.18](#)
SI (System International)
Units of Measure [5.3](#)
Software ID Number [5.26](#)
Software Revision [5.26](#)
specifications [A.13](#) - [A.14](#)
startup [6.2](#)
system [4.2](#) - [4.3](#)
System Error [5.2](#), [5.23](#)
System Group [5.2](#) - [5.3](#)

T

technical assistance [1](#)
terminals [A.14](#)
Test Displays [5.29](#)
Test Outputs [5.29](#)
troubleshooting alarms [6.4](#) - [6.5](#)
troubleshooting errors [6.4](#) - [6.5](#)

U

US Units of Measure [5.3](#)
User Operation Mode [5.11](#)

W

warranty information back cover
WatLink [2.9](#)
wiring [3.2](#) - [3.10](#)
write to a single register [A.4](#)
write to multiple registers [A.4](#) - [A.5](#)
writing a modbus application [A.2](#)

Parameter Index (alphabetical order)

A

Alarm Active Sides [5.20](#)
Alarm Condition [5.17](#)
Alarm High [5.19](#)
Alarm Hysteresis [4.11, 5.20](#)
Alarm Latching Mode [5.20 - 5.21](#)
Alarm Logic [5.21](#)
Alarm Low [6.21 - 5.18 - 5.19](#)
Alarm Output Function [5.19](#)
Alarm Output Group [5.17 - 5.21](#)
Alarm Output Hardware [5.17 - 5.18](#)
Alarm Silencing Mode [5.21](#)
Alarm Type [5.19 - 5.20](#)
Ambient Temperature [5.2](#)
Analog-to-digital Counts [5.27 - 5.28](#)
Auto-tune Set Point [5.13](#)

C

Calibration Commands [5.30](#)
Calibration Group [5.30 - 5.31](#)
Calibration Mode [5.30](#)
Calibration Offset [4.4, 5.6](#)
Characteristics Group [5.25 - 5.26](#)
CJC Counts [5.27](#)
Clear Alarm [5.18](#)
Clear Error [5.23](#)
Control Output Function [5.8 - 5.9](#)
Control Output Group [5.8 - 5.10](#)
Control Output Hardware [5.8](#)
C or F [5.3](#)
Cycle Time [5.15 - 5.16](#)

D

Date of Manufacture [5.25](#)
Decimal Point [5.3](#)
Derivative [5.15](#)
Diagnostics Group [5.27 - 5.29](#)
Diagnostics Mode [5.29](#)
Disable Non-volatile Memory [5.2](#)

E

Enter Calibration Mode [5.30](#)
Enter Diagnostics Mode [5.29](#)
Error Clearing Mode [5.24](#)
Error Group [5.22 - 5.24](#)

F

Factory Calibration [5.30 - 5.31](#)
Filter Time Constant [4.5, 5.7](#)
Fixed Manual Output [5.10](#)

H

High Side Power [5.9](#)

I

Initiate Auto-tune [5.17](#)
Input Actual [5.4](#)
Input Counts [5.27](#)
Input Error [5.4, 5.23 - 5.24](#)
Input Error action [5.7, 5.22 - 5.23](#)
Input Group [5.4 - 5.7](#)
Input Type [5.5](#)
Integral [5.14](#)

L

Low Side Power [5.9 - 5.10](#)

M

Manual Output Power [5.12](#)
Model Number [5.27](#)

N

Non-volatile Memory [5.2](#)

O

Open Loop Detect [4.14, 5.22](#)
Open Loop Error [5.22](#)
Operation Mode [5.11](#)
Output Hysteresis [5.16](#)
Output Power [5.13](#)

P

PID Group [5.13 - 5.16](#)
PID Output Power [5.13](#)
Power Limit Set Point [5.9](#)
Propband [5.14](#)

R

Range High [4.6, 5.6](#)
Range Low [4.6, 5.6](#)
Rate [5.15](#)
Reset [5.15](#)
Restore Factory Calibration [5.30 - 5.31](#)
Restore Factory Defaults [5.31](#)
RTD Lead Compensation [5.28](#)
RTD Lead Resistance [5.28](#)

S

Sensor Type [5.5](#)
Serial Number 1 [5.25](#)
Serial Number 2 [5.26](#)

Set Point [5.12](#)
Ship Date [5.25](#)
Shutdown [6.3](#)
SI (System International)
Units of Measure [5.3](#)
Silence Alarm [5.18](#)
Software ID Number [5.26](#)
Software Revision [5.26](#)
System Error [5.2, 5.23](#)
System Group [5.2 - 5.3](#)

T

Test Displays [5.29](#)
Test Outputs [5.29](#)

U

US Units of Measure [5.3](#)
User Operation Mode [5.11](#)

Required Parameters Setup Order also found on [page 2.8](#)

This table provides 1) the correct order of entry, 2) the affect of a parameter, and 3) a place to document your settings.

Changing this →
Affects this ↓

CAUTION:
Parameters should be set up in this order.

Key:
D = Changing will change the default
C = Changing will convert the temperature scale
O = Other effect
 (See Parameter Index, [p. A.18](#), for detail)

Document your settings below

	Units Type	C or F	Control Output Function	Sensor Type	Input Type	Range Low	Range High	High Side Power	Low Side Power	Alarm Type	Operation Mode	Decimal
Units Type												
C or F												
Input Error Action												
Control Output Function												
Set Fixed Manual Output			O									
Open Loop Detect												
Sensor Type												
Input Type				O								
Range Low		C	D	D							C	
Range High		C	D	D							C	
Decimal Point			D	D								
Calibration Offset		C	D	D							C	
Filter Time Constant			D	D								
Error Clearing Mode												
Power Limit Set Point		C	D	D							C	
High Side Power			O									
Low Side Power			O									
Alarm Output Function												
Alarm Type				D	D							
Alarm Hysteresis		C	D	D							C	
Alarm Latching Mode												
Alarm Silencing Mode												
Alarm Active Sides												
Alarm Logic												
Alarm High		C	D	D					O		C	
Alarm Low		C	D	D					O		C	
Propband		C	D	D							C	
Integral		O										
Reset		O										
Derivative												
Rate												
Cycle Time												
Output Hysteresis		C	D	D							C	
Operation Mode												
Set Point												
Manual Output Power			O				O	O	O			
Set Point		C	D	D	O	O					C	

Table A.19 - Parameters Setup order.

How to Reach Us



Quality and Mission Statement:

Watlow Controls will be the world's best supplier of industrial temperature control products, services, and systems by exceeding our customers', employees', and shareholders' expectations.

Contact

Your Authorized Watlow Distributor is:

- or Phone: (507) 454-5300.
- Fax: (507) 452-4507.
- For technical support, ask for an Applications Engineer.
- To place an order, ask for Customer Service.
- To discuss a custom option, ask for a MicroDIN Product Manager.

Warranty

The Watlow MicroDIN is warranted to be free of defects in material and workmanship for 36 months after delivery to the first purchaser for use, providing that the units have not been misapplied. Since Watlow has no control over their use, and sometimes misuse, we cannot guarantee against failure. Watlow's obligations hereunder, at Watlow's option, are limited to replacement, repair or refund of purchase price, and parts which upon examination prove to be defective within the warranty period specified. This warranty does not apply to damage resulting from transportation, alteration, misuse, or abuse.

Returns

- Call or fax Customer Service for a Return Material Authorization (RMA) number before returning a control.
- Put the RMA number on the shipping label, and also on a description of the problem.
- 20% of net price restocking charge applies to all standard units returned to stock.

Watlow MicroDIN User's Manual