 **IntesisBox<sup>®</sup>**  
**ME-AC-MBS-1-2I10 v.1.13**

MODBUS RTU (RS-485) Interface for Mitsubishi Electric air conditioners, with 2 general purpose digital inputs and one digital output.

Compatible with all models of Domestic & Mr.Slim lines.

**User's Manual**  
Rev. 9

Order Code: **ME-AC-MBS-1-2I10**

**© Intesis Software S.L. 2009. All Rights Reserved.**

Information in this document is subject to change without notice. No part of this publication may be reproduced, stored in a retrieval system or transmitted in any form or any means electronic or mechanical, including photocopying and recording for any purpose other than the purchaser's personal use without the written permission of Intesis Software S.L.

Intesis Software S.L.  
Milà i Fontanals, 1 bis - 1<sup>º</sup>  
08700 Igualada  
Spain

**TRADEMARKS**

All trademarks and tradenames used in this document are acknowledged to be the copyright of their respective holders.

**INDEX**

1.	Presentation .....	4
2.	Connection .....	5
2.1	Connection to the AC indoor unit.....	5
2.2	Connection to the RS485 bus.....	6
2.3	Connection of the general purpose digital inputs and output .....	6
3.	Modbus Interface Specification .....	7
3.1	Modbus physical layer.....	7
3.2	Modbus Registers .....	7
3.2.1	Control and status registers .....	7
3.2.2	Configuration Registers .....	8
3.2.3	Auxiliary Registers .....	9
3.3	DIP-switch Configuration Interface .....	10
3.4	Implemented Functions.....	11
3.5	Configuration of the device.....	11
3.6	Device LED indicator.....	12
3.7	RS485 bus. Termination resistors and Fail Safe Biasing mechanism .....	12
4.	Specifications.....	14
5.	List of supported AC Unit Types.....	15
6.	Available features for each type of AC Unit. ....	16
7.	Error Codes .....	19

## 1. Presentation



The ME-AC-MBS-1-2I10 interface allows a complete and natural integration of **Mitsubishi Electric** air conditioners into Modbus RTU (RS-485) networks.

Compatible with all AC models of Domestic and Mr.Slim lines.

- Reduced dimensions. 93 x 53 x 58 mm.
- Quick and easy installation.  
*Mountable on DIN rail, wall, or even inside the indoor unit in some models of AC.*
- External power not required.
- Direct connection to MODBUS RTU (RS-485) networks. Up to 254 ME-AC-MBS-1-2I10 devices can be connected in the same network.  
*ME-AC-MBS-1-2I10 is a Modbus slave device.*
- Direct connection to the AC indoor unit.  
*The cable for this connection is also supplied.*
- Configuration from both on-board DIP-switches and MODBUS RTU.
- Total Control and Supervision.
- Real states of the AC unit's internal variables.
- Allows to use simultaneously the IR remote control and MODBUS RTU.
- 2 general purpose digital inputs plus 1 relay output available through Modbus registers.

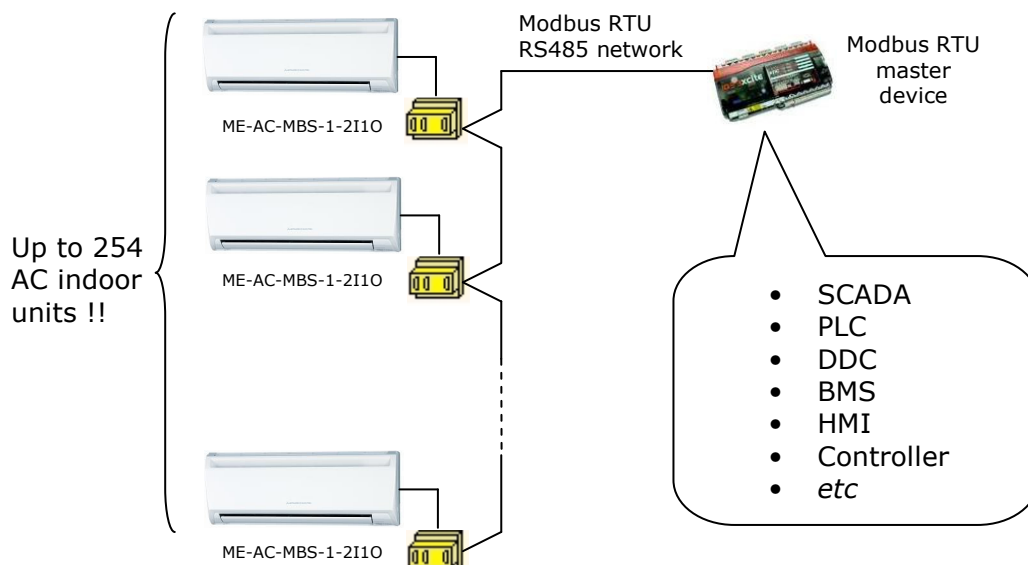

## 2. Connection

The interface comes with a cable for direct connection to the AC indoor unit, a plug-in terminal block of 2 poles for connection to a Modbus RTU RS-485 network, and a plug-in terminal block of 5 poles for connection of external equipment in its general purpose digital inputs and output.

### 2.1 Connection to the AC indoor unit

Disconnect mains power from the AC unit. Open the front cover of the indoor unit in order to have access to the electronic circuit. In the electronic circuit locate the socket connector marked as:

**CN92** in Mr.Slim models, or **CN105** in the rest of models.

Using the cable that comes with the interface, insert one of its connectors, the one installed in the shortest uncovered part, into the socket of the ME-AC-MBS-1-2I10, and the other connector, the one installed in the largest uncovered part, to the socket **CN92** or **CN105** of the AC unit's electronic circuit. You can place the ME-AC-MBS-1-2I10 inside or outside the AC indoor unit depending on your needs, remember that ME-AC-MBS-1-2I10 must be also connected to the Modbus RTU RS-485 network. Close the AC indoor unit's front cover again.

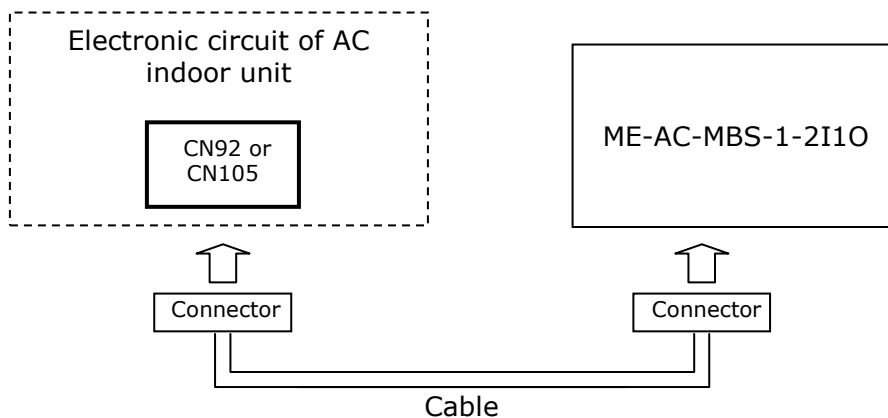

Do not modify the length of the cable supplied with the interface, it may affect to the correct operation of the interface.

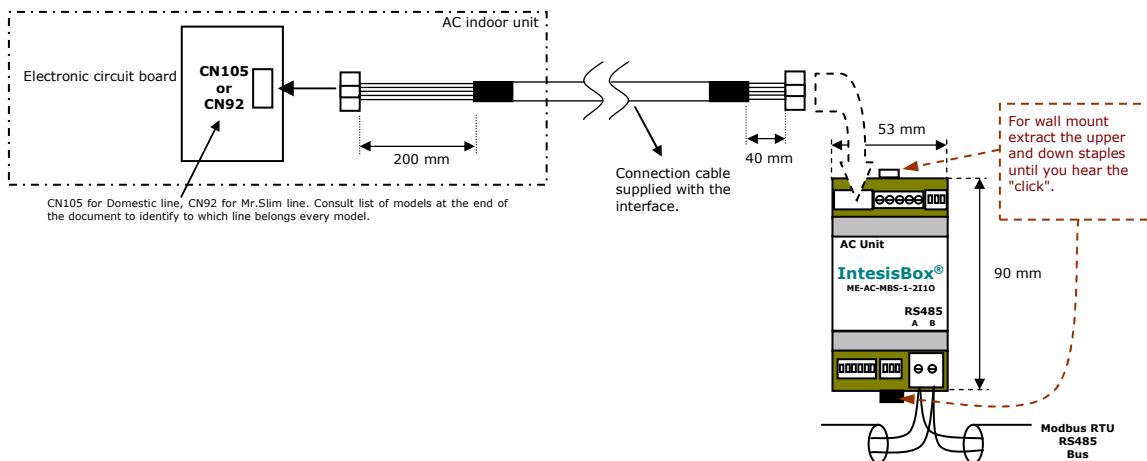

## 2.2 Connection to the RS485 bus

Connect the RS485 bus wires to the plug-in terminal block (the one of two poles) of ME-AC-MBS-1-2I10, respect the polarity on this connection (A+ and B-). Respect the maximum distance of 1.200 meters for the bus, no loop or star topologies are allowed for RS485 bus, a terminator resistor of 120  $\Omega$  must be present at each end of the bus to avoid signal reflections and also a fail safe biasing mechanism (see section 3.7 for more details).

## 2.3 Connection of the general purpose digital inputs and output

Connect dry contacts of other devices to the 2 digital inputs of ME-AC-MBS-1-2I10 as shown below. *Connect only dry contacts of other devices as internal polarization is given by ME-AC-MBS-1-2I10.*

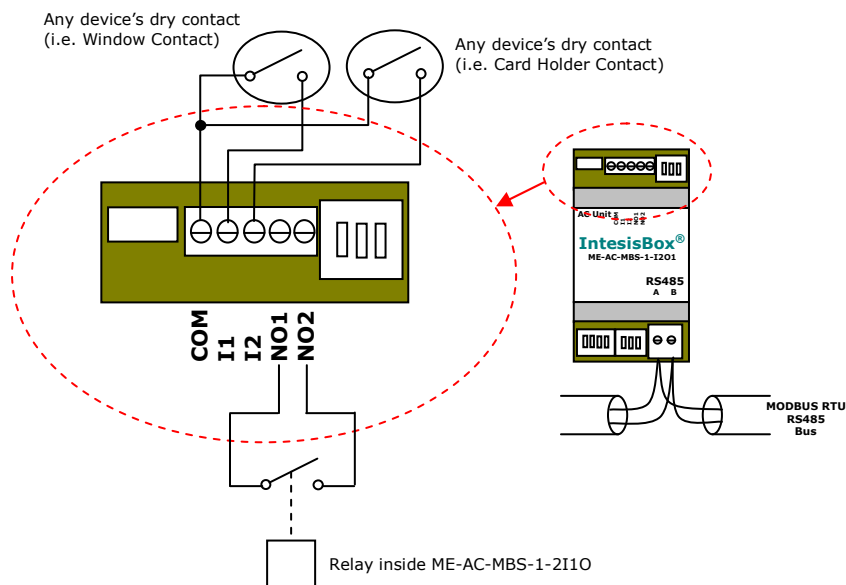

The relay output is also a dry contact normally open that can actuate any device with the following restrictions: 30VDC/5A, or 250VAC/5A max.

The monitoring of the state of the inputs as well as the activation/deactivation of the relay can be done using modbus registers of ME-AC-MBS-1-2I10 (see section 3.2 for details).

### 3. Modbus Interface Specification

#### 3.1 Modbus physical layer

ME-AC-MBS-1-2I10 implements a MODBUS RTU (slave) interface, to be connected to an RS-485 line. It performs an 8N1 communication (8 data bits, no parity and 1 stop bit) with several available baudrates (2400 bps, 9600 bps -default-, 19200 bps and 57600 bps).

#### 3.2 Modbus Registers

All registers are of type "16-bit unsigned Holding Register", in standard modbus' big endian notation.

##### 3.2.1 Control and status registers

Register Addr (protocol address)	Register Addr (PLC address)	R/W	Description
0	1	R/W	AC unit On/Off <ul style="list-style-type: none"> <li>▪ 0: Off</li> <li>▪ 1: On</li> </ul>
1	2	R/W	AC unit Mode <sup>1</sup> <ul style="list-style-type: none"> <li>▪ 0: Auto</li> <li>▪ 1: Heat</li> <li>▪ 2: Dry</li> <li>▪ 3: Fan</li> <li>▪ 4: Cool</li> </ul>
2	3	R/W	AC unit Fan Speed <sup>1</sup> <ul style="list-style-type: none"> <li>▪ 0: Auto</li> <li>▪ 1: Low</li> <li>▪ 2: Mid-1</li> <li>▪ 3: Mid-2</li> <li>▪ 4: High</li> </ul>
3	4	R/W	AC unit Vane Position <sup>1</sup> <ul style="list-style-type: none"> <li>▪ 0: Auto</li> <li>▪ 1: Horizontal</li> <li>▪ 2: Position-2</li> <li>▪ 3: Position-3</li> <li>▪ 4: Position-4</li> <li>▪ 5: Vertical</li> <li>▪ 6: Swing</li> </ul>
4	5	R/W	AC unit Temperature Setpoint <sup>1,2</sup> <ul style="list-style-type: none"> <li>▪ 16..31 (°C)</li> <li>▪ 61..90 (°F)</li> </ul>
5	6	R	AC unit Ambient Temperature <sup>2</sup> <ul style="list-style-type: none"> <li>▪ 10..38 (°C)</li> <li>▪ 50..100 (°F)</li> </ul>
6	7	R/W	Window Contact <ul style="list-style-type: none"> <li>▪ 0: Closed</li> <li>▪ 1: Open</li> </ul>

<sup>1</sup> See Section 6 for detail on indoor unit model differences and function availability

<sup>2</sup> Magnitude for this register can be adjusted to Celsius (default) or Fahrenheit through DIP switch P5

Register Addr (protocol address)	Register Addr (PLC address)	R/W	Description
7	8	R/W	Device Disablement <sup>3</sup> <ul style="list-style-type: none"> <li>0: ME-AC-MBS-1-2I10 enabled</li> <li>1: ME-AC-MBS-1-2I10 disabled</li> </ul>
8	9	R/W	IR Remote Command Disablement <sup>3</sup> <ul style="list-style-type: none"> <li>0: Remote Command enabled</li> <li>1: Remote Command disabled</li> </ul>
9	10	R/W	AC unit Operation Time <sup>3</sup> <ul style="list-style-type: none"> <li>0..65535 (hours). Counts the time the AC unit is in "On" state.</li> </ul>
10	11	R	AC unit Alarm Status <ul style="list-style-type: none"> <li>0: No alarm condition</li> <li>1: Alarm condition</li> </ul>
11	12	R	Error Code <sup>4</sup> <ul style="list-style-type: none"> <li>8000: No error present</li> <li>8001: Error in the communication of ME-AC-MBS-1-2I10 against the AC unit</li> <li>65535 (-1 if read as signed value): Status of AC error has not been obtained yet (initialization value)</li> <li>Any other: Error present. See table at the end of this document.</li> </ul>

### 3.2.2 Configuration Registers

Register Addr (protocol address)	Register Addr (PLC address)	R/W	Description
12	13	R/W	AC Model* * For firmware versions 1.10 onwards (value 266 in register 51) it is NOT needed to setup AC model on the interface, so this register is not used (its value is always "0")
13	14	R/W	"Open Window" switch-off timeout <sup>5, 3</sup> <ul style="list-style-type: none"> <li>0..30 (minutes)</li> <li>Factory setting: 30 (minutes)</li> </ul>
14	15	R/W	Modbus RTU baud-rate <sup>6, 3</sup> <ul style="list-style-type: none"> <li>0: 2400 bps</li> <li>1: 9600 bps</li> <li>2: 19200 bps</li> <li>3: 57600 bps</li> <li>Factory setting: 1 (9600 bps)</li> </ul>
15	16	R/W	Device's Modbus slave address <sup>6, 3</sup> <ul style="list-style-type: none"> <li>1..255</li> <li>Factory setting: 0 (no address / configured at DIP-switch)</li> </ul>

<sup>3</sup> This value is stored in non-volatile memory

<sup>4</sup> See Section 7 for possible error codes and its explanation

<sup>5</sup> Once window contact is open, a count-down to switch off the AC Unit will start from this configured value

<sup>6</sup> This value can also be set-up from device's on-board DIP-switches. See Section 3.3



### 3.2.3 Auxiliary Registers

Register Addr (protocol address)	Register Addr (PLC address)	R/W	Description
16	17	R	Digital Input I1 <ul style="list-style-type: none"> <li>▪ 0: Open contact</li> <li>▪ 1: Closed contact</li> </ul>
17	18	R	Digital Input I2 <ul style="list-style-type: none"> <li>▪ 0: Open contact</li> <li>▪ 1: Closed contact</li> </ul>
18	19	R/W	Relay Output O1 <ul style="list-style-type: none"> <li>▪ 0: Relay deactivated (contact open)</li> <li>▪ 1: Relay activated (contact closed)</li> </ul>
50	51	R	Software version

### 3.3 DIP-switch Configuration Interface

All configuration values on ME-AC-MBS-1-2I10 can be written and read from modbus interface. Though, some of them can also be setup from its on-board DIP-switch interface.

They are DIP-switches P5, P6\* and P7 on the device, in the following location:

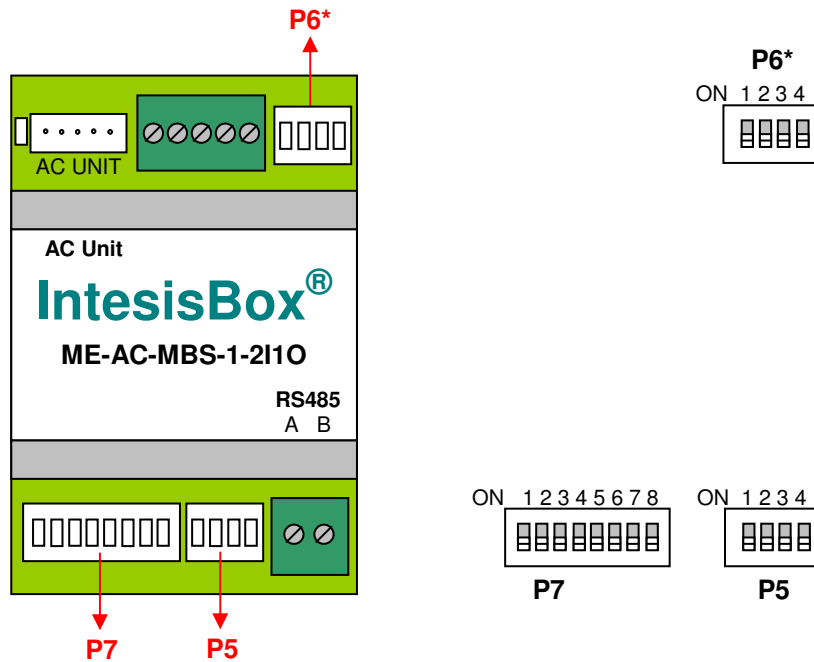

The following table applies for configuration of the interface through these DIP-switches:

DIP SWITCH	Binary value	Decimal value	Switch Position	Description
P7 (modbus address)	00000000	0	1 2 3 4 5 6 7 8 ↓ ↓ ↓ ↓ ↓ ↓ ↓ ↓	Slave Address configured through modbus register 15 (and not through DIP-Switch interface)
	1 2.....8 b <sub>0</sub> b <sub>1</sub> .....b <sub>7</sub>	X	1:b <sub>0</sub> ... 8:b <sub>7</sub> ▪ OFF ↓ for 0 ▪ ON ↑ for 1	Slave Address <sup>7</sup> , 1..255 (in binary)
P5 (baudrate)	0xxx	0	1 2 3 4 ↓ x x x	Baudrate configured through modbus register 14 (and not through DIP-Switch interface)
	1xxx	1	1 2 3 4 ↑ x x x	9600 bps

<sup>7</sup> Device comes from factory with no configured slave address. It must be set up during first installation (either in DIP-switch interface, or by using modbus broadcast messages). See section 3.5

DIP SWITCH	Binary value	Decimal value	Switch Position	Description
P5 (temperature magnitude)	x0xx	0	<pre> 1 2 3 4 x ↓ x x                     </pre>	Temperature magnitude in register addresses 5 and 6 is Celsius (default – factory value)
	x1xx	1	<pre> 1 2 3 4 x ↑ x x                     </pre>	Temperature magnitude in register addresses 5 and 6 is Fahrenheit

\*DIP-Switch P6 is not used by current version of ME-AC-MBS-1-2I10

### 3.4 Implemented Functions

ME-AC-MBS-1-2I10 implements the following standard MODBUS functions:

- 3: Read Holding Registers
- 4: Read Input Registers
- 6: Write Single Register
- 16: Write Multiple Registers (Although this function is allowed, the interface does not allow write operations on more than 1 register with the same request, this means that length field should always be 1 when using this function for writes)

### 3.5 Configuration of the device

During first installation, it is necessary to appropriately set-up, at least, the following configuration parameters (in parenthesis its default / factory value):

- Modbus Slave Address (0 / no address)
- Modbus Baudrate (9600 bps)

All of them can be setup from both, modbus registers or P5 and P7 DIP-Switch interfaces.

Device comes from factory with all DIP-Switches set at low level (all zero / position OFF↓). At this point, the device can be configured by following one of the two following methods:

- Start an RS-485 8N1 communication at 9600 bps with the device, and setup registers 15 (Slave Address) and 14 (Baudrate) by sending broadcast messages (with Slave Address field = 0). Note that ME-AC-MBS-1-2I10 always receives broadcast messages, though they are never answered back (to avoid collisions).
- Configure DIP-Switch interface using values shown in Section 3.3

Note that, setting up a different baudrate than 9600 bps must be done from Modbus interface. This implies that, once this value has been changed to another baudrate, modbus interface will cease receiving data at previous baudrate (as new baudrate configuration immediately applies). So, immediately after changing baudrate configuration, remember to change the baudrate of the modbus master communicating with ME-AC-MBS-1-2I10.

In case that it is desired to configure the interface using its modbus configuration registers (instead of DIP-Switches), remember to keep all micro-switches at low level (all zero / position ↓). Otherwise, configuration at DIP-Switches will prevail over the values configured at modbus registers.

### 3.6 Device LED indicator

The device includes a LED indicator to signal its different possible operational states. In the following table are presented the different indications it can perform and its meaning.

Device status	LED indication	ON / OFF Period	Meaning
On power-up	LED pulse	ON for 5 seconds / OFF after	Device reset / power-up
During normal operation	LED flashing	200ms ON / 2s OFF	Device correctly configured and working
During normal operation	LED OFF	OFF continuously	No modbus slave address configured
During normal operation	LED blinking	200ms ON / 200ms OFF	Communication Error with the AC unit

### 3.7 RS485 bus. Termination resistors and Fail Safe Biasing mechanism

RS485 bus requires a 120Ω terminator resistor at each end of the bus to avoid signal reflections.

In order to prevent fail status detections by the receivers "listening" the bus when all the transmitters outputs are in three-state (high impedance), it is also required a fail safe biasing mechanism. This mechanism provides a safe status (a correct voltage level) in the bus when all the transmitters' outputs are in three-state.

ME-AC-MBS-1-2I10 incorporates an on-board terminator resistor of 120Ω that can be connected to the RS485 bus by using DIP-switch P5 (see below).

A fail safe biasing circuit has also been included in the board of the ME-AC-MBS-1-2I10, it can be connected to the RS485 bus by placing the internal jumpers JP2 and JP3 (see details below). This fail safe biasing of the RS485 bus must only be supplied by one of the devices connected to the bus. As this fail safe biasing circuit also provides a termination resistance, only one of both must be selected in the ME-AC-MBS-1-2I10, fail safe biasing (*jumpers JP2 and JP3 placed*) or terminator resistor (*DIP-switch P5 position 4 to ON*).

The device providing fail safe biasing or terminator resistor should be the one connected at one end of the bus. At the other end of the bus, if there is also a ME-AC-MBS-1-2I10 device, select the 120Ω terminator resistor through DIP-switch P5, or if there is a master device not providing internal 120Ω terminator resistor, connect an external 120Ω resistor in the bus terminal block connection of such master device.

*Some Modbus RTU RS485 master devices can provide also internal 120Ω terminator resistor and/or fail safe biasing (consult the technical documentation of the master device connected to the RS485 network in every case).*

Location of jumpers and DIP-switches for RS485 bus Termination resistor or Fail Safe Biasing selection:

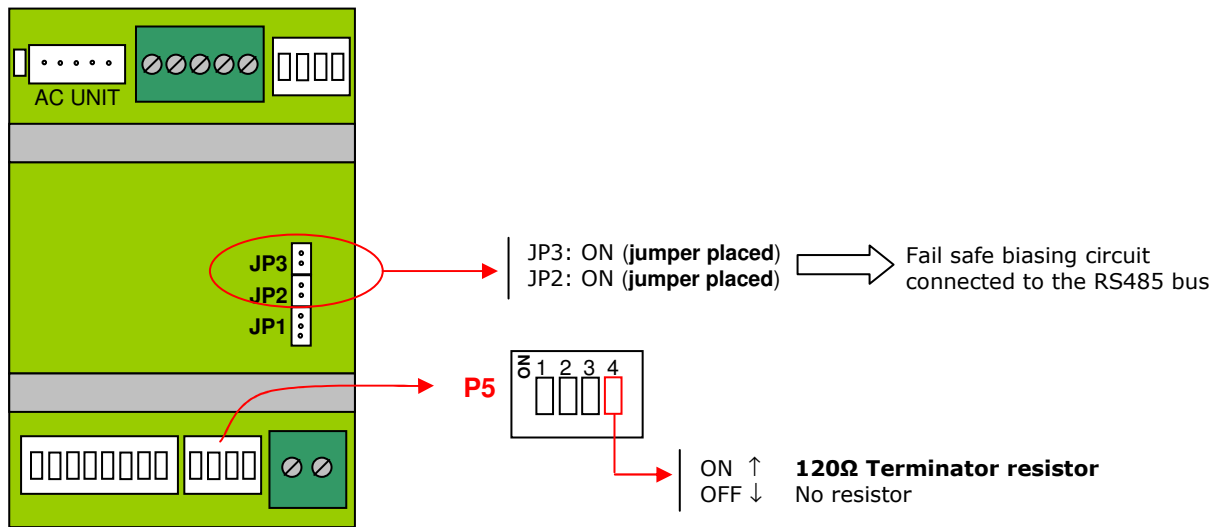

To access to internal jumpers JP2 and JP3, extract the top cover of the interface inserting a small screw-driver or clip in the holes located at both sides of the cover.

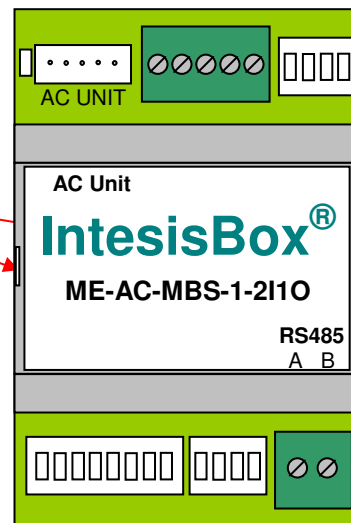

## 4. Specifications

Dimensions	93 x 53 x 58 mm
Weight	85 g
Operating Temperature	-40 . . . 85°C
Stock Temperature	-40 . . . 85°C
Operating Humidity	<95% RH, non-condensing
Stock Humidity	<95% RH, non-condensing
Isolation voltage	1000 VDC
Isolation resistance	1000 MΩ
Modbus Media	Compatible with Modbus RTU - RS485 networks
Digital inputs	For connection of dry contacts of other devices. Internal polarization is given by ME-AC-MBS-1-2I10.
Relay output	Dry contact. 35VDC/5a or 250VAC/5A max.

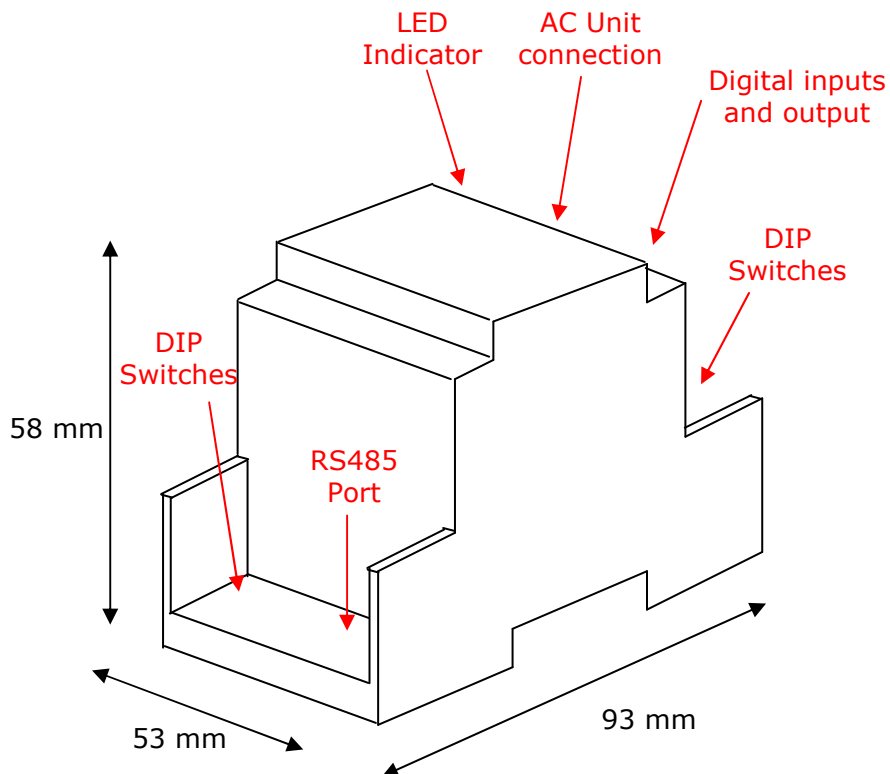

## 5. List of supported AC Unit Types.

Prefix (first part) of the AC unit model number.	Line
MFZ-KA...	Domestic
MLZ-KA...	Domestic
MSZ-FA...	Domestic
MSZ-FD...	Domestic
MSZ-GA22..., MSZ-GA25..., MSZ-GA35..	Domestic
MSZ-GA50..., MSZ-GA60..., MSZ-GA71..	Domestic
MSZ-GB...	Domestic
MSZ-GC...	Domestic
MSZ-GE...	Domestic
MSZ-SF...	Domestic
PCA-RP GA	Mr Slim
PCA-RP KA	Mr Slim
PEA-RP200...	Mr Slim
PEA-RP400...	Mr Slim
PEAD-JA...	Mr Slim
PEAD-RP...	Mr Slim
PEFY-P20-140VMA-E	City Multi
PEH-RP200-250...	Mr Slim
PKA-RP35-50HAL	Mr Slim
PKA-RP60-71-100KAL	Mr Slim
PKA-RP100FAL	Mr Slim
PLA-RP AA2	Mr Slim
PLA-RP BA	Mr Slim
PSA...	Mr Slim
SEZ-KA...	Mr Slim
SEZ-KD...	Mr Slim
SLZ-KA...	Mr Slim

**Any AC unit with a model number not specified in this list (in column *Prefix*), is not compatible with the interface and can not be used.**

## 6. Available features for each type of AC Unit.

Supported AC unit models will differ each other in the features they offer, with regard to following functionalities:

- Number of different operation modes
- Number of different fan speeds
- Number of different vane positions
- Range of temperature set points, which may also depend on the mode of operation of the unit (heat, cool, ...)

In case that modbus registers for *operation mode*, *fan speed*, *vane position* or *temperature setpoints* are written to a value that is not supported by the AC unit under control, the AC unit will ignore the setting. In general, this situation should be avoided: only those values supported by the AC unit under control should be written in the appropriate modbus register.

This list shows the available features in each supported AC type.

MFZ-KA...			Temperature Set Point			
Mode	Fan Speed	Vane Pos	Heat	Cool	Dry	Auto
HEAT, DRY, COOL, AUTO	AUTO, LOW, MID1, MID2, HIGH	0,1,2,3,4,5,6	16..31	16..31	16..31	16..31

MLZ-KA...			Temperature Set Point			
Mode	Fan Speed	Vane Pos	Heat	Cool	Dry	Auto
HEAT, DRY, COOL, AUTO	AUTO, LOW, MID1, MID2	0,1,2,3,4,5,6	16..31	16..31	16..31	16..31

MSZ-FA...			Temperature Set Point			
Mode	Fan Speed	Vane Pos	Heat	Cool	Dry	Auto
HEAT, DRY, COOL, AUTO	AUTO, LOW, MID1, MID2	0,1,2,3,4,6	16..31	16..31	16..31	16..31

MSZ-FD...			Temperature Set Point			
Mode	Fan Speed	Vane Pos	Heat	Cool	Dry	Auto
HEAT, DRY, COOL, AUTO	AUTO, LOW, MID1, MID2, HIGH	0,1,2,3,4,5,6	16..31	16..31	16..31	16..31

MSZ-GA22..., MSZ-GA25..., MSZ-GA35..			Temperature Set Point			
Mode	Fan Speed	Vane Pos	Heat	Cool	Dry	Auto
HEAT, DRY, COOL, AUTO	AUTO, LOW, MID1, MID2	0,1,2,3,4,5,6	16..31	16..31	16..31	16..31

MSZ-GA50..., MSZ-GA60..., MSZ-GA71..			Temperature Set Point			
Mode	Fan Speed	Vane Pos	Heat	Cool	Dry	Auto
HEAT, DRY, COOL, AUTO	AUTO, LOW, MID1, MID2	0,1,2,3,4,5,6	16..31	16..31	16..31	16..31

MSZ-GB...			Temperature Set Point			
Mode	Fan Speed	Vane Pos	Heat	Cool	Dry	Auto
HEAT, DRY, COOL, AUTO	AUTO, LOW, MID1, MID2	0,1,2,3,4,6	16..31	16..31	16..31	16..31

MSZ-GC...			Temperature Set Point			
Mode	Fan Speed	Vane Pos	Heat	Cool	Dry	Auto
HEAT, DRY, COOL, AUTO	AUTO, LOW, MID1, MID2, HIGH	0,1,2,3,4,5,6	16..31	16..31	16..31	16..31

MSZ-GE...			Temperature Set Point			
Mode	Fan Speed	Vane Pos	Heat	Cool	Dry	Auto
HEAT, DRY, COOL, AUTO	AUTO, LOW, MID1, MID2, HIGH	0,1,2,3,4,5,6	16..31	16..31	16..31	16..31



<b>MSZ-SF...</b>			Temperature Set Point			
Mode	Fan Speed	Vane Pos	Heat	Cool	Dry	Auto
HEAT, DRY, COOL, AUTO	AUTO, LOW, MID1, MID2, HIGH	0,1,2,3,4,5,6	16..31	16..31	16..31	16..31

<b>PCA-RP GA</b>			Temperature Set Point			
Mode	Fan Speed	Vane Pos	Heat	Cool	Dry	Auto
HEAT, DRY, COOL, FAN, AUTO	LOW, MID1, MID2, HIGH*	1,3,4,5,6	17..28	19..30	19..30	19..28

\*HIGH speed may not be available in some older versions of this AC type

<b>PCA-RP KA</b>			Temperature Set Point			
Mode	Fan Speed	Vane Pos	Heat	Cool	Dry	Auto
HEAT, DRY, COOL, FAN, AUTO	AUTO, LOW, MID1, MID2, HIGH	0,1,2,3,4,5,6	17..28	19..30	19..30	19..28

<b>PEA-RP200...</b>			Temperature Set Point			
Mode	Fan Speed	Vane Pos	Heat	Cool	Dry	Auto
HEAT, DRY, COOL, FAN, AUTO	LOW, MID2	(no vanes)	17..28	19..30	19..30	19..28

<b>PEA-RP400...</b>			Temperature Set Point			
Mode	Fan Speed	Vane Pos	Heat	Cool	Dry	Auto
HEAT, DRY, COOL, FAN, AUTO	(single fan speed)	(no vanes)	17..28	19..30	19..30	19..28

<b>PEAD-JA...</b>			Temperature Set Point			
Mode	Fan Speed	Vane Pos	Heat	Cool	Dry	Auto
HEAT, DRY, COOL, FAN, AUTO	AUTO, LOW, MID1, MID2	(no vanes)	17..28	19..30	19..30	19..28

<b>PEAD-RP...</b>			Temperature Set Point			
Mode	Fan Speed	Vane Pos	Heat	Cool	Dry	Auto
HEAT, DRY, COOL, FAN, AUTO	LOW, MID2	(no vanes)	17..28	19..30	19..30	19..28

<b>PEFY-P20-140VMA-E</b>			Temperature Set Point			
Mode	Fan Speed	Vane Pos	Heat	Cool	Dry	Auto
HEAT, DRY, COOL, FAN, AUTO*	AUTO, LOW, MID1, MID2	(no vanes)	17..28	19..30	19..30	19..28

\*AUTO operation mode is only available when using outdoor units PURY or PQRY

<b>PEH-RP200-250...</b>			Temperature Set Point			
Mode	Fan Speed	Vane Pos	Heat	Cool	Dry	Auto
HEAT, DRY, COOL, FAN, AUTO	(single fan speed)	(no vanes)	17..28	19..30	19..30	19..28

<b>PKA-RP35-50HAL</b>			Temperature Set Point			
Mode	Fan Speed	Vane Pos	Heat	Cool	Dry	Auto
HEAT, DRY, COOL, FAN, AUTO	AUTO, LOW, MID1, MID2	0,1,2,3,4,5,6	17..28	19..30	19..30	19..28

<b>PKA-RP60-71-100KAL</b>			Temperature Set Point			
Mode	Fan Speed	Vane Pos	Heat	Cool	Dry	Auto
HEAT, DRY, COOL, FAN, AUTO	AUTO, LOW, MID1, MID2	0,1,2,3,4,5,6	17..28	19..30	19..30	19..28

<b>PKA-RP100FAL</b>			Temperature Set Point			
Mode	Fan Speed	Vane Pos	Heat	Cool	Dry	Auto
HEAT, DRY, COOL, FAN, AUTO	LOW, MID2	1,3,4,5,6	17..28	19..30	19..30	19..28

<b>PLA-RP AA2</b>			Temperature Set Point			
Mode	Fan Speed	Vane Pos	Heat	Cool	Dry	Auto
HEAT, DRY, COOL, FAN, AUTO	LOW, MID1, MID2	1,3,4,5,6	17..28	19..30	19..30	19..28

<b>PLA-RP BA</b>			Temperature Set Point			
Mode	Fan Speed	Vane Pos	Heat	Cool	Dry	Auto
HEAT, DRY, COOL, FAN, AUTO	AUTO, LOW, MID1, MID2, HIGH	0,1,2,3,4,5,6	17..28	19..30	19..30	19..28

PSA...			Temperature Set Point			
Mode	Fan Speed	Vane Pos	Heat	Cool	Dry	Auto
HEAT, DRY, COOL, FAN, AUTO	LOW, MID2	(no vanes)	17..28	19..30	19..30	19..28

SEZ-KA...			Temperature Set Point			
Mode	Fan Speed	Vane Pos	Heat	Cool	Dry	Auto
HEAT, DRY, COOL, FAN, AUTO	LOW, MID2	(no vanes)	17..28	19..30	19..30	19..28

SEZ-KD...			Temperature Set Point			
Mode	Fan Speed	Vane Pos	Heat	Cool	Dry	Auto
HEAT, DRY, COOL, FAN, AUTO	AUTO, LOW, MID1, MID2	(no vanes)	17..28	19..30	19..30	19..28

SLZ-KA...			Temperature Set Point			
Mode	Fan Speed	Vane Pos	Heat	Cool	Dry	Auto
HEAT, DRY, COOL, FAN, AUTO	LOW, MID1, MID2	1,3,4,5,6	17..28	19..30	19..30	19..28

## 7. Error Codes

Code (In Hexadecimal)	Description
8000	No active error
1102	Discharge Temperature high
1108	Internal thermostat detector working (49C)
1110	Outdoor unit fail
1300	Pressure low
1302	Pressure high (High pressure probe working 63H)
1503	Protection against freeze or battery high temperature
1504	Protection against freeze or battery high temperature
1504	Over heating protection
1509	High pressure error (ball valve closed)
1520	Super heating anomaly due to low temp. of discharge. (TH4)
2500	Erroneous operation of drain pump
2502	Erroneous operation of drain pump
2503	Drain sensor anomaly (DS)
4030	Serial transmission error
4100	Compressor pause due to excess of current (initial block)
4101	Compressor pause due to excess of current (overload)
4102	Phase detection opened
4103	Anti-phase detection
4108	Phase opened in phase L2 or connector 51CM opened
4118	Error in the anti-phase detector (electronic board)
4124	Connector 49L opened
4210	Cut due to over-current of compressor
4220	Voltage anomaly
4230	Radiator panel temperature anomaly (TH8)
5101	Ambient temperature probe anomaly (TH1), indoor unit
5102	Liquid probe anomaly (TH2)
5102	Cond/Evap probe anomaly (TH5)
5104	Error detection in discharge temperature
5105	Outdoor probe error TH3
5106	Outdoor probe error TH7
5107	Outdoor probe error TH6
5110	Outdoor probe error TH8
5202	Connector 63L opened
5300	Current probe error
6600	MNET duplicated address definition
6602	MNET Line transmission hardware error
6603	MNET BUS busy
6606	MNET Line transmission error
6607	MNET transmission error
6607	MNET without ack
6608	MNET transmission error
6608	MNET without response
6831	IR remote control transmission error (reception error)
6832	IR remote control transmission error (transmission error)
6840	Transmission error with the indoor/outdoor unit (reception error)
6841	Transmission error with the indoor/outdoor unit (transmission error)
6844	Error in inter-connection cable in the indoor/outdoor unit, indoor unit number deactivated (5 min or more)
6845	Error in inter-connection cable in the indoor/outdoor unit (cabling error, disconnection)
6846	Initial timer deactivated
8001	ME-AC-MBS-1-2I1O device communication error
65535 (-1 if read as a signed value)	Status of error has not been obtained from AC yet (initialization value)

In case you detect an error code not listed, contact your nearest Mitsubishi Electric technical support service.