

RMS 5533



User Manual

- Manual #: RGB-RD-UM-R5533 E001
- Revision: V1.1



RMS 5533·User Manual

Thank you for choosing our products!

In order to allow you to learn how to use the Rack Mount Monitor quickly, we bring you the detailed user's guide. You can read the introduction and directions before using the Rack Mount Monitor, please read all the information we provide carefully to use our products correctly.

Copyright

©2012 All rights are reserved by RGBlink.

This document is done independently by Xiamen RGBlink Science & Technology Co.,LTD. No part can be copied, reproduced or translated without permission.

Notice

RGBlink provides this manual "as is" without warranty of any kind, no matter expressed or implied, including but not limited to the implied warranties or merchantability and fitness for a particular purpose. RGBlink may make improvements or changes to the products and the programs described in this publication at any time without notice.

This publication would contain technical inaccuracies or typographical errors. Changes are periodically made to the information in this publication; these changes are incorporated in new editions of this publication.

Federal Communications

Commission (FCC) Statement

This equipment has been tested and found to comply with the limits for a class A digital device, pursuant to Part 15 of the FCC rules. These limits are designed to provide reasonable protection against harmful interference when the equipment is operated in a commercial environment. This equipment generates, uses and radiates radio frequency energy and, if not installed or used in accordance with the instruction manual, may cause harmful

interference to radio communications. Operation of this equipment in a residential area may cause harmful interference, in which case the user will be responsible for correcting any interference.

Guarantee and Compensation

RGBlink provides a guarantee related to perfect manufacturing as part of the legally stipulated terms of guarantee. On receipt, the purchaser must immediately inspect all delivered goods for damage incurred during transportation, as well as for material and manufacturing faults. Please complain to RGBlink by written notice.

The period of guarantee begins from the date of transfer of risks, in the case of special systems and software on the date of commissioning, at latest 30 days after the transfer of risks. In the event of justified notice of compliant, RGBlink can repair the fault or provide a replacement at its own discretion within an appropriate period. If this measure proves to be impossible or unsuccessful, the purchaser can demand a reduction in the purchase price or cancellation of the contract. All other claims, in particular those relating to compensation for direct or indirect damage, and also damage attributed to the operation of software as well as to other service provided by RGBlink, being a component of the system or independent service, will be deemed invalid provided the damage is not proven to be attributed to the absence of properties guaranteed in writing or due to the intent or gross negligence or part of RGBlink.

If the purchaser or a third party carries out modifications or repairs on goods delivered by RGBlink, or if the goods are handled incorrectly, in particular if the systems are commissioned operated incorrectly or if, after the transfer of risks, the goods are subject to influences not agreed upon in the contract, all guarantee claims of the purchaser will be rendered invalid. Not included in the guarantee coverage are system failures which are attributed to programs or special electronic circuitry provided by the purchaser, e.g. interfaces. Normal wear as well as normal maintenance are not subject to the guarantee provided by RGBlink either.

The environmental conditions as well as the servicing and maintenance regulations specified in this manual must be complied with the customer.

Trademark

Brand and product names mentioned in this manual may be trademarks, registered trademarks or copyrights of their respective holders. All brand and product names mentioned in this manual serve as comments or examples and are not to be understood as advertising for the products or their manufactures.

Company Address



Xiamen RGBlink Science & Technology Co., Ltd.

Headquarter: S603~604 Weiye Building Torch Hi-Tech Industrial Development Zone Xiamen, Fujian Province, P.R.C

Shenzhen office: Building 3, A Baiwang Plaza, Xili Nanshan District, Shenzhen, Guangdong Province, P.R.C

Beijing office: Room 602, Building 7, CaiManJie, No.67, Chaoyang Road, Chaoyang District, Beijing, P.R.C

Shanghai office: Building 3, 1358 Nong, Tongpu Road, Shanghai, P.R.C

- **Tel:** +86-592-5771197
- **Fax:** +86-592-5771202
- **Websites:**
 - ~ <http://www.rgblink.com>
 - ~ <http://www.rgblink.cn>
- **E-mail:** rgblinkcs@gmail.com

Safe Operation Summary

The general safety information in this summary is for operating personnel.

Do Not Remove Covers or Panels

There are no user-serviceable parts within the unit. Removal of the rear panel will expose dangerous voltages. To avoid personal injury, do not remove the rear panel. Do not operate the unit without the panel installed.

Use the Proper Properly

This product is intended to operate from a power source that will not apply more than 230 volts rms between the supply conductors or between both supply conductor and ground. A protective ground connection by way of grounding conductor in the power cord is essential for safe operation.

Ground the Product Properly

This product is grounded through the grounding conductor of the power cord. To avoid electrical shock, plug the power cord into a properly wired receptacle before connecting to the product input or output terminals. A protective-ground connection by way of the grounding conductor in the power cord is essential for safe operation.

Use the Proper Power Cord

Use only the power cord and connector specified for your product. Use only a power cord that is in good condition. Refer cord and connector changes to qualified service personnel.

Use the Proper Fuse

To avoid fire hazard, use only the fuse having identical type, voltage rating, and current rating characteristics. Refer fuse replacement to qualified service personnel.

Do Not Operate in Explosive Dangerous Atmospheres

To avoid explosion, do not operate this product in an explosive atmosphere.

Terms and Equipment Mark in This Manual



WARNING

Highlight an operating procedure, practice, condition, statement, etc, which, if not strictly observed, could result in injury or death of personnel.

Note

Highlights an essential operating procedure, condition or statement.



CAUTION

The exclamation point within an equilateral triangle is intended to alert the user to the presence of important operating and maintenance (servicing) instructions in the literature accompanying the appliance.

Amendment Record

The table below lists the changes to the Rack Mount Monitor User's Guide.

Format	Time	ECO#	Description	Principal
1.0	2012-11-02	0000	Release	BIN
1.1	2013-01-31	0001	Interface Upgrade	Vira



CONTENT

CONTENT	10
1. Brief Introduction	13
Chapter Structure.....	14
Manual Usage	15
Terms and Definitions	16
Product Feature	22
2. Panel Instruction	24
In This Chapter	24
RMS 5533 Front Panel.....	25
1. PHONE: 3.5mm Earphone jack.....	25
2. POWER: Power on/off indicator.....	25
3. SOURCE: Input signal selection	25
4. F1: User defined function key 1.....	25
5. F2: User defined function key 2.....	25
6. Aspect Ratio.....	26
7. DISPLAY: Display current settings.....	26
8. MENU.....	26
9. OK: Select and Apply.....	26

10. TALLY Light.....	26
RMS 5533 Rear Panel	27
1: Power	27
2: SDI Loop Through Output.....	27
3: SDI Input.....	27
4: CVBS Input	27
5: CVBS Loop Through Output.....	27
6: TALLY controlling port.....	28
7: DVI/VGA Loop Through Output.....	28
8: DVI/VGA Input.....	28
9: USB Port.....	28
3. Menu Operation	30
In This Chapter	30
MENU	31
System Submenu.....	32
Picture Submenu.....	33
OSD Submenu	34
Display Submenu	35
F Key Submenu.....	36
VGA Setup Submenu	37
4. System Setup and Operation.....	38

In This Chapter	38
How to Turn On/Off the Monitor	39
How to Monitor Audio	40
How to Choose the Signal	41
How to Use User Defined Function Key	42
How to Display Aspect Ratio	43
How to Display Current Settings	44
5. TALLY Light Operation	45
A. Specification.....	46
B. Contact Information.....	48
C. RMS 5533 Optional Module: SDI Input Module.....	49

1. Brief Introduction



This chapter is designed to introduce you to the RMS 5533 User Manual. It covers:

- [Chapter Structure](#)
- [Manual Usage](#)
- [Terms and Definitions](#)
- [Product Feature](#)

1. Brief Introduction

Chapter Structure

Chapter Structure

The following chapters provide instructions for all aspects of RMS 5533 operations:

- Chapter 1 [Brief Introduction](#)
- Chapter 2 [Panel Instruction](#)
- Chapter 3 [Menu Operation](#)
- Chapter 4 [System Setup and Operation](#)
- Chapter 5 [TALLY Light Operation](#)
- Appendix A [Specification](#)
- Appendix B [Contact Information](#)
- Appendix C [RMS 5533 Optional Module: SDI Input Module](#)

1. Brief Introduction

Manual Usage

Manual Usage

Following are important tips for streamlining your use of this User's Guide in its electronic "PDF" form.

Navigation

Use Acrobat Reader's "bookmarks" to navigate to the desired location. All chapter files have the same bookmark structure for instant navigation to any section. Please note:



- Extensive hyperlinks are provided within the chapters.
- Use Acrobat's "**Go to Previous View**" and "**Return to next View**" buttons to trace your complete navigational path.



- Use the "**Previous Page**" and "**Next Page**" buttons to go to the previous or next page within a file.
- Use Acrobat's extensive search capabilities, such as the "**Find**" tool and "**Search Index**" tool to perform comprehensive searches as required.

Catalogue and Index

Use the Table of Contents bookmarks to navigate a desired topic. Click any item to instantly jump to that section of the guide. You can also use the **Index** to jump to specific topics within a chapter. Each page number in the **Index** is a hyperlink.

1. Brief Introduction

Terms and Definitions

Terms and Definitions

The following terms and definitions are used throughout this guide;

- **"ASCII"**: American Standard for Information Interchange. The standard code consisting of 7-bit coded characters (8 bits including parity check) used to exchange information between data processing systems, data communication systems, and associated equipment. The ASCII set contains control characters and graphic characters.
- **"Aspect ratio"**: The relationship of the horizontal dimension to the vertical dimension of an image. In viewing screens, standard TV is 4:3, or 1.33:1; HDTV is 16:9, or 1.78:1. Sometimes the ":1" is implicit, making TV = 1.33 and HDTV = 1.78.
- **"AV"**: Audio visual or audio video.
- A **"Background"** is an unscaled source, typically originating from a computer. A background source appears at the system's lowest priority — visually in back of all other sources.
- **"Baudrate"**: Named of J.M.E. Baudot, the inventor of the Baudot telegraph code. The number of the electrical oscillations per second, called baud rate. Related to, but not the same as, transfer rate in bits per second (bps).
- **"Blackburst"**: The video waveform without the video elements. It includes the vertical sync, horizontal sync, and the chroma burst information. Blackburst is used to synchronize video equipment to align the video output. One signal is normally used to set up an entire video system or facility. Sometimes it is called House sync.
- **"BNC"**: Bayonet Neill-Concel man. A cable connector used extensively in television and named for its inventors. A cylindrical bayonet connector that operates with a twist-locking motion. To make the connection, align the two curved grooves in the collar of the male connector with the two projections on the outside of the female collar, push, and twist. This allows the connector to lock into place without tools.
- **"Brightness"**: Usually refers to the amount or intensity of video light produced on a screen without regard to color. Sometimes called "black level."
- **"CAT 5"**: Category 5. Describes the network cabling standard that consists of four unshielded twisted pairs of copper wire terminated by RJ-45 connectors. CAT 5 cabling supports data rates up to 100 Mbps. CAT 5 is based on the EIA/TIA 568

1. Brief Introduction

Terms and Definitions

Commercial Building Telecommunications Wiring Standard.

- **“Color bars”**: A standard test pattern of several basic colors (white, yellow, cyan, green, magenta, red, blue, and black) as a reference for system alignment and testing. In NTSC video, the most commonly used color bars are the SMPTE standard color bars. In PAL video, the most commonly used color bars are eight full field bars. In the computer, the most commonly used color bars are two rows of reversed color bars.
- **“Color burst”**: In color TV systems, a burst of sub-carrier frequency located on the back porch of the composite video signal. This serves as a color synchronizing signal to establish a frequency and phase reference for the chrome signal. Color burst is 3.58 MHz for NTSC and 4.43 MHz for PAL.
- **“Color temperature”**: The color quality, expressed in degrees Kelvin (K), of a light source. The higher the color temperature, the bluer the light. The lower the temperature, the redder the light. Benchmark color temperature for the A/V industry includes 5000°K, 6500°K, and 9000°K.
- **“Contrast ratio”**: The ratio of the high light output level divided by the low light output level. In theory, the contrast ratio of the television system should be at least 100:1, if not 300:1. In reality, there are several limitations. In the CRT, light from adjacent elements contaminate the area of each element. Room ambient light will contaminate the light emitted from the CRT. Well-controlled viewing conditions should yield a practical contrast ratio of 30:1 to 50:1.
- **“DVI”**: Digital Visual Interface. The digital video connectivity standard that was developed by DDWG (Digital Display Work Group). This connection standard offers two different connectors: one with 24 pins that handles digital video signals only, and one with 29 pins that handles both digital and analog video.
- **“EDID”**: Extended Display Identification Data – EDID is a data structure used to communicate video display information, including native resolution and vertical interval refresh rate requirements, to a source device. The source device will then output the optimal video format for the display based on the provided EDID data, ensuring proper video image quality. This communication takes place over the DDC – Display Data Channel.
- **“Ethernet”**: A Local Area Network (LAN) standard officially known as IEEE 802.3. Ethernet and other LAN technologies are used for interconnecting computers, printers, workstations, terminals, servers, etc. within the same building or campus. Ethernet operates over twisted pair and over coaxial cable at

1. Brief Introduction

Terms and Definitions

speeds starting at 10Mbps. For LAN interconnectivity, Ethernet is physical link and data link protocol reflecting the two lowest layers of the OSI Reference Model.

- **“Frame”**: In interlaced video, a frame is one complete picture. A video frame is made up of two fields, or two sets of interlaced lines. In a film, a frame is one still picture of a series that makes up a motion picture.
- **“Gamma”**: The light output of a CRT is not linear with respect to the voltage input. The difference between what you should have and what is actually output is known as gamma.
- **“HDMI” - High – Definition Multimedia Interface**: An interface used primarily in consumer electronics for the transmission of uncompressed high definition video, up to 8 channels of audio, and control signals, over a single cable. HDMI is the de facto standard for HDTV displays, Blu-ray Disc players, and other HDTV electronics. Introduced in 2003, the HDMI specification has gone through several revisions.
- **“HDSDI”**: The high-definition version of SDI specified in SMPTE-292M. This signal standard transmits audio and video with 10 bit depth and 4:2:2 color quantization over a single coaxial cable with a data rate of 1.485 Gbit/second. Multiple video resolutions exist including progressive 1280x720 and interlaced 1920x1080 resolutions. Up to 32 audio signals are carried in the ancillary data.
- **“JPEG” (Joint photographic Expects Group)**: Commonly used method of lost compression for photographic images using a discreet cosine transfer function. The degree of compression can be adjusted, allowing a selectable tradeoff between storage size and image quality. JPEG typically achieves 10:1 compression with little perceptible loss in image quality. Produces blocking artifacts.
- **“MPEG”**: Motion Picture Expect Group. A standard committee under the auspices of the International Standards Organization working on algorithm standards that allow digital compression, storage and transmission of moving image information such as motion video, CD-quality audio, and control data at CD-ROM bandwidth. The MPEG algorithm provides inter-frame compression of video images and can have an effective compression rate of 100:1 to 200:1.
- **“NTSC”**: The color video standard used in North America and some other parts of the world created by the National Television Standards Committee in the 1950s. A color signal must be compatible with black-and-white TV sets. NTSC utilizes an interlaced video signals, 525 lines of resolution with a refresh rate of 60 fields per second (60 Hz). Each frame is

1. Brief Introduction

Terms and Definitions

comprised of two fields of 262.5 lines each, running at an effective rate of 30 frames per second.

- **"PAL"**: Phase Alternate Line. A television standard in which the phase of the color carrier is alternated from line to line. It takes four full pictures (8 fields) for the color-to-horizontal phase relationship to return to the reference point. This alternation helps cancel out phase errors. For this reason, the hue control is not needed on a PAL TV set. PAL, in many transmission forms, is widely used in Western Europe, Australia, Africa, the Middle East, and Micronesia. PAL uses 625-line, 50-field (25 fps) composite color transmission system.
- **"Operator"**: Refers to the person who uses the system.
- **"PIP"**: Picture-in-Picture. A small picture within a larger picture created by scaling down one of the images to make it smaller. Each picture requires a separate video source such as a camera, VCR, or computer. Other forms of PIP displays include Picture-by-Picture (PBP) and Picture-with-Picture (PWP), which are commonly used with 16:9 aspect display devices. PBP and PWP image formats require a separate scaler for each video window.
- **"Polarity"**: The positive and negative orientation of a signal. Polarity usually refers to the direction or a level with respect to a reference (e.g. positive sync polarity means that sync occurs when the signal is going in the positive direction).
- **"RJ-45"**: Registered Jack-45. A connector similar to a telephone connector that holds up to eight wires used for connecting Ethernet devices.
- **"RS-232"**: An Electronic Industries Association (EIA) serial digital interface standard specifying the characteristics of the communication path between two devices using either DB-9 or DB-25 connectors. This standard is used for relatively short-range communication and does not specify balanced control lines. RS-232 is a serial control standard with a set number of conductors, data rate, word length, and type of connector to be used. The standard specifies component connection standards with regard to the computer interface. It is also called RS-232-C, which is the third version of the RS-232 standard, and is functionally identical to the CCITT V.24 standard.

1. Brief Introduction

Terms and Definitions

- **“Saturation”**: Chroma, chroma gain. The intensity of the color, or the extent to which a given color in any image is free from white. The less white in a color, the truer the color or the greater its saturation. On a display device, the color control adjusts the saturation. Not to be confused with the brightness, saturation is the amount of pigment in a color, and not the intensity. Low saturation is like adding white to the color. For example, a low-saturated red looks pink.
- **“Scaling”**: A conversion of a video or computer graphic signal from a starting resolution to a new resolution. Scaling from one resolution to another is typically done to optimize the signal for input to an image processor, transmission path or to improve its quality when presented on a particular display.
- **“SDI”**: Serial Digital Interface. The standard based on a 270 Mbps transfer rate. This is a 10-bit, scrambled, polarity independent interface with common scrambling for both component ITU-R 601 and composite digital video and four channels of (embedded) digital audio.
- **“Seamless Switching”**: A feature found on many Extron video switchers. This feature causes the switcher to wait until the vertical interval to switch. This avoids a glitch (temporary scrambling) which normally is seen when switching between sources.
- **“SMPTE”**: Society of Motion Picture and Television Engineers. A global organization, based in the United States that sets standards for base band visual communications. This includes film as well as video and television standards.
- **“S-video”**: A composite video signal separated into the luma (“Y” is for luma, or black and white information; brightness) and the chroma (“C” is an abbreviation for chroma, or color information).
- **“Sync”**: Synchronization. In video, sync is a means of controlling the timing of an event with respect to other events. This is accomplished with timing pulses to insure that each step in a process occurs at the correct time. For example, horizontal sync determines exactly when to begin each horizontal scan line. Vertical sync determines when the image

1. Brief Introduction

Terms and Definitions

is to be refreshed to start a new field or frame. There are many other types of sync in video system.(Also known as "sync signal" or "sync pulse.")

- **"TCP/IP"**: Transmission Control Protocol/Internet Protocol. The communication protocol of the Internet. Computers and devices with direct access to the Internet are provided with a copy of the TCP/IP program to allow them to send and receive information in an understandable form.
- **"USB"**: Universal Serial Bus. USB was developed by seven PC and telecom industry leaders (Compaq, DEC, IBM, Intel, Microsoft, NEC, and Northern Telecom). The goal was easy plug-and-play expansion outside the box, requiring no additional circuit cards. Up to 127 external computer devices may be added through a USB hub, which may be conveniently located in a keyboard or monitor. USB devices can be attached or detached without removing computer power. The number of devices being designed for USB continues to grow, from keyboards, mice, and printers to scanners, digital cameras, and ZIP drives.
- **"VESA"**: Video Electronics Standards Association. A nonprofit number organization dedicated to facilitating and promoting personal computer graphics through improved standards for the benefit of the end-user. www.vesa.org.
- **"VGA"**: Video Graphics Array. Introduced by IBM in 1987, VGA is an analog signal with TTL level separate horizontal and vertical sync. The video outputs to a 15-pin HD connector and has a horizontal scan frequency of 31.5 kHz and vertical frequency of 70 Hz (Mode 1, 2) and 60 Hz (Mode 3). The signal is non-interlaced in modes 1, 2, and 3 and interlaced when using the 8514/A card (35.5 kHz, 86 Hz) in mode 4. It has a pixel by line resolution of 640×480 with a color palette of 16 bits and 256,000 colors.
- **"YCrCb"**: Used to describe the color space for interlaced component video.
- **"YPbPr"**: Used to describe the color space for progressive-scan (non-interlaced) component video.

1. Brief Introduction

Product Feature

Product Feature

- **High Resolution LCD Panel**

Consists of three 5-inch, 16:9, 800X480 LCD panel, with wide viewing angle and 19-inch 3U rack mount.

- **Underscan and Overscan**

Switch between underscan and overscan mode.

- **Pixel to pixel zoom-in**

The real time zoom-in function is to enlarge to the input video as pixel to pixel from the center.

- **Safe area**

The safe area is offered to mark an area of picture that can be seen on the television screens.

- **Multi Input/Output**

Support SDI, DVI, VGA and CVBS loop out.

- **3G SDI Input**

Accept 3G/HD/SD SDI input.

- **SDI embedded audio output**

Convert SDI embedded audio to analog and output via 3.5mm earphone.

- **DVI embedded audio output**

Convert DVI embedded audio to analog and output via 3.5mm earphone.

- **Image flip**

Rotate the image by 180°.

- **User defined function keys**

There are 2 function keys on the monitor front panel, and users could define the functions to achieve shortcut.

1. Brief Introduction

Product Feature

- **User defined video title**

User can edit a video title for the current camera, and the title will display on the top of screen.

2. Panel Instruction



In This Chapter

This chapter provides detailed information about the RMS 5533 panel. The following topics are discussed:

- [RMS 5533 Front Panel](#)
- [RMS 5533 Rear Panel](#)

2. Panel Instruction

RMS 5533 Front Panel

RMS 5533 Front Panel

Front view:

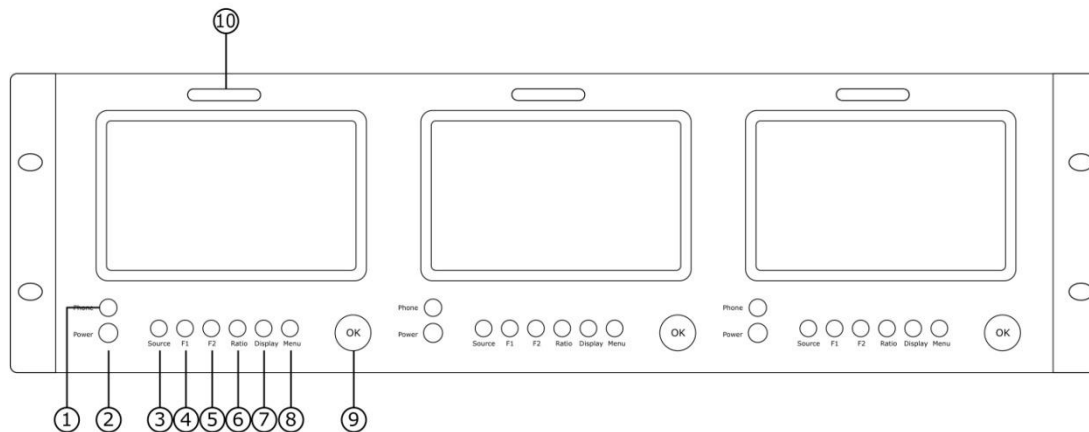

1. PHONE: 3.5mm Earphone jack

For HDMI (supported by DVI input) embedded audio monitoring.

2. POWER: Power on/off indicator

Connect with power cable, press the "POWER" and the power indicator is turned on and after 10 seconds, the monitor will be switched on and get into working status.

Press the "POWER" again, the indicator is turned off and monitor is switched off.

The monitor will memory the state before shutdown, and will keep the state when startup the computer next time.

Note

Disconnect with power cable if the monitor will not be used for a period of time.

3. SOURCE: Input signal selection

Press "SOURCE" and push "OK" rotary to select the input video signal: Video, DVI, VGA, SDI (SDI is optional module).

4. F1: User defined function key 1

5. F2: User defined function key 2

2. Panel Instruction

RMS 5533 Front Panel

6. Aspect Ratio

Press "RATIO", 16:9 and 4:3 switch.

7. DISPLAY: Display current settings

Press "DISPLAY" to display safety mark, title and the current input signal information.

8. MENU

9. OK: Select and Apply

Push "OK" rotary to adjust settings and press to apply.

Note

Out of menu system, directly push "OK" rotary to adjust volume.

10. TALLY Light

Red, Green and Yellow 3-color TALLY indicator (Version 1.1 does not support currently).

2. Panel Instruction

RMS 5533 Rear Panel

RMS 5533 Rear Panel

Rear view:

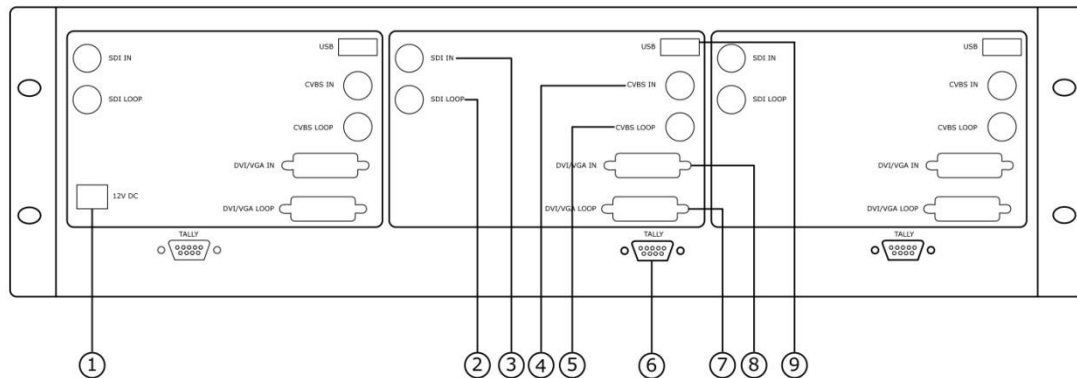

NO.	INTERFACE	NO.	INTERFACE
1	Power	6	TALLY Controlling
2	SDI Loop Through Output	7	DVI/VGA Loop Through Output
3	SDI Input	8	DVI/VGA Input
4	CVBS Input	9	USB Port
5	CVBS Loop Through Output		

1: Power

DC 12V IN: Connect with DC12V power adapter. Power polarity is: negative inside and cathode outside.

2: SDI Loop Through Output

SDI-LOOP: Standard BNC connector.

3: SDI Input

SDI-IN: Standard BNC Connector.

4: CVBS Input

CVBS-IN: Composite video input (BNC connector).

5: CVBS Loop Through Output

CVBS-LOOP: Composite video loop through output (BNC

2. Panel Instruction

RMS 5533 Rear Panel

connector, it is valid only when switch the signal to AV channel).

6: TALLY controlling port

TALLY controlling port (RS232) (Version 1.1 does not support currently).

7: DVI/VGA Loop Through Output

DVI/VGA-LOOP: DVI/VGA Loop through output.

Note

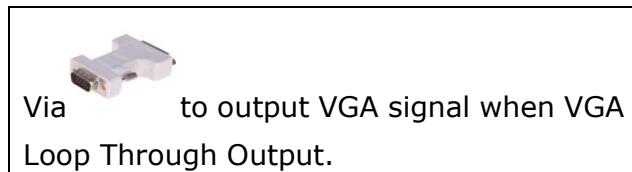

8: DVI/VGA Input

DVI/VGA -IN: DVI/VGA input.

Note

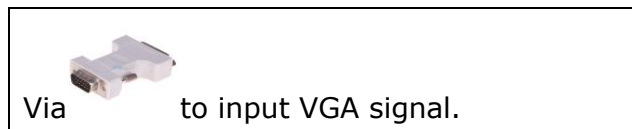

9: USB Port

USB Port: Used to software upgrade.

Note

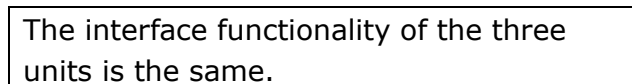

2. Panel Instruction

RMS 5533 Rear Panel

- **Input formats**

Input	Supported formats
CVBS	PAL/NTSC
DVI	480i / 576i / 480p / 576p
	1080i (60 / 59.94 / 50)
	720p (60 / 59.94 / 50)
	1080p (60 / 59.94 / 50 / 30 / 29.97 / 25 / 24 / 23.98)
VGA	800x600@60Hz
	1024x768@60Hz
	1024x768@75Hz
	1280x720@60Hz
	1280x768@60Hz
	1280x800@60Hz
	1280x1024@60Hz
	1360x768@60Hz
	1366x768@60Hz
	1400x1050@60Hz
	1440x900@60Hz
	1600x1200@60Hz
	1680x1050@60Hz
1920x1080@60Hz	
SDI	SMPTE-425M 1080p (60 / 59.94 / 50)
	SMPTE-274M 1080i (60 / 59.94 / 50)
	SMPTE-296M 720p (60 / 59.94 / 50)
	SMPTE-125M 480i (59.94)
ITU-R BT.656 576i (50)	

3. Menu Operation

In This Chapter

This chapter provides menu operation about the RMS 5533. Including: how to be visited, the available functions, and the description of menu item.

The following topics are discussed:

- ◆ MENU
- ◆ System Submenu
- ◆ Picture Submenu
- ◆ OSD Submenu
- ◆ Display Submenu
- ◆ F Key Submenu
- ◆ VGA Setup Submenu

3. Menu Operation

MENU

MENU

Language setting

The language in menu is optional, it includes Chinese, English, etc. English is the default language.

Following is the operation for how to change English to Chinese, and the opposite applies as well.

1. Press "MENU" to enter to menu.
2. Push "OK" rotary to select "OSD" and press "OK" to ensure.
3. Enter to "OSD" to select "LANGUAGE" and press "OK" to ensure.
4. Press "OK" to change "ENGLISH" to "CHINESE".
5. Press "MENU" to return to menu system.

Submenu setting

1. Press "MENU" and it will display menu system;
2. Push "OK" rotary to select an item. The selected item will be highlighted display yellow.
Press "OK" (select yellow) to enter the selected item, push "OK" rotary to select the parameter.
3. Under menu system, press "MENU" to back to previous menu.
Press "MENU" to exit.

3. Menu Operation

System Submenu

System Submenu



The System Submenu includes:

1. **RATIO:** Aspect ratio has two options, 16:9 and 4:3.
2. **SCAN:** "UNDERSCAN" / "OVERSCAN" selection.
3. **ZOOM:** "OFF", "ZOOM1" and "ZOOM2" selection.
ZOOM1: Canon DSLR scale zoom-in.
ZOOM2: Pixel to Pixel zoom-in.
4. **MARKER:** Select and set the safe area scale from 80%, 85%, 90% and 95%.
5. **FLIP:** Select "ON" and press "OK" to flip the picture by 180°.
6. **RESET:** Select "OK" to recover all to factory setting.
7. **TITLE:** User defined title.

Yellow is the selected letters, push "OK" rotary to select the letters, and press "OK" to input. Max 10 letters are supported. After setting, press "OK" to ensure, the system will display the user defined title.

3. Menu Operation

Picture Submenu

Picture Submenu

SYSTEM	PICTURE	OSD	DISPLAY	FKEY	VGA Setup
	CONTRAST		50		
	BRIGHTNESS		50		
	SATURATION		50		
	SHARPNESS		50		
	CLR TEMP		Medium		
	PIC MODE		Standard		
	HUE		50		

▲ ▼ MENU OK

The Picture Submenu includes:

1. CONTRAST: 0~100
2. BRIGHTNESS: 0~100
3. SATURATION: 0~100
4. SHARPNESS: 0~100
5. COLOR TEMP: color temperature, cool selection, normal, warm, user defined.
6. PIC MODE: user defined and preset picture modes, vivid selection, standard, soft, user defined.
7. HUE: 0~100 (Only available under CVBS NTSC input, other signal display gray and can not be adjusted).

3. Menu Operation

OSD Submenu

OSD Submenu



The OSD Submenu includes:

1. LANGUAGE: Chinese, English, etc.
2. H-POSITION: Menu horizontal position (0-100) adjustment.
3. V-POSITION: Menu vertical position (0-100) adjustment.
4. DURATION: Menu timeout setting (5-60s), it will automatically quit if the menu remains idle, and default: Off.

3. Menu Operation

Display Submenu

Display Submenu

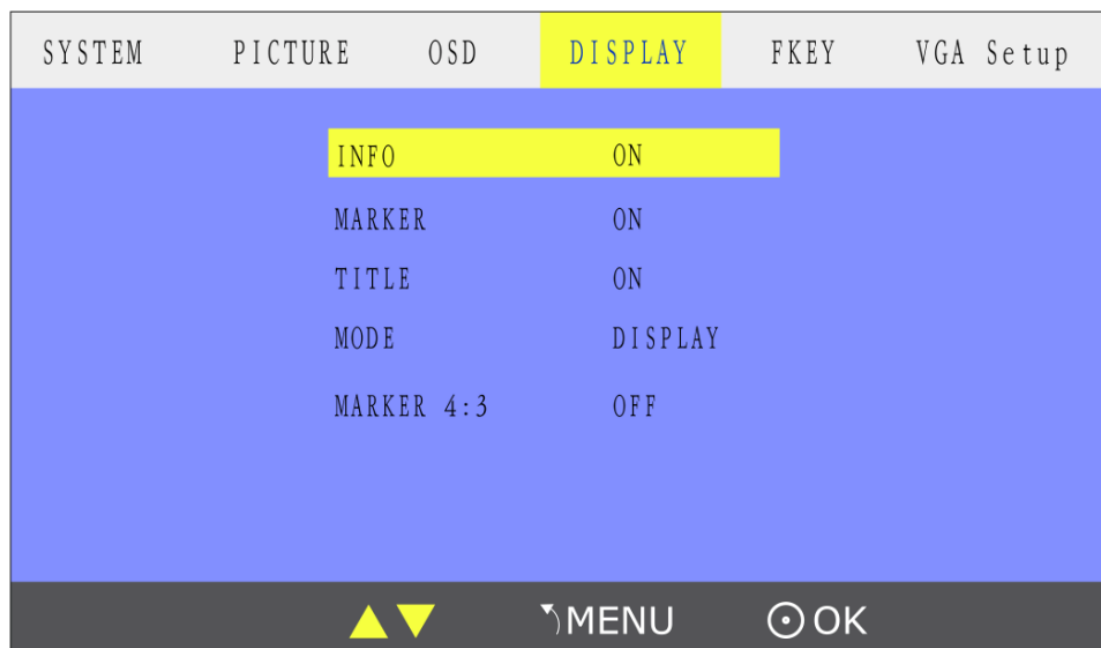

Enter to "DISPLAY" submenu, to set the following items:

1. INFO: Select "ON", screen will display "Input Format", "RATIO", "SCAN", "MARKER", "FLIP", "ZOOM" at the up-left.
2. MARKER: Safe area. Select "ON", screen will display the safe area, and select "OFF" to close it.
3. TITLE: User edited title.
4. MODE: "DISPLAY" or "TEST PATTEN". Select and press "DISPLAY", screen will display the image. Select "TEST PATTEN" and press "DISPLAY", screen will display test patten to check if LCD screen operate normally.
5. MARKER 4:3: The 4:3 scale mark on 16:9 image (only available under HD input).

3. Menu Operation

F Key Submenu

F Key Submenu



Enter to "FKEY" submenu, user defined F1/F2 functions.

The available function items are:

RATIO: Aspect ratio switch

SCAN: Underscan / Overscan switch

ZOOM: Picture Zoom-in

FLIP: Image flip

PIC MODE: Preset picture mode switch

CLR TEMP: Color-temperature switch

B/W: Color / Black & white switch

Note

The FUN. KEY Settings Submenu is to define Function Key F1 and F2.

Via USB input, enter to "Software Upgrade (USB)", and select "ON" can achieve upgrade software.

Software Version: Display the current software version information. (For read only).

SDI Version: Display the current SDI version information. (For read only).

3. Menu Operation

VGA Setup Submenu

VGA Setup Submenu

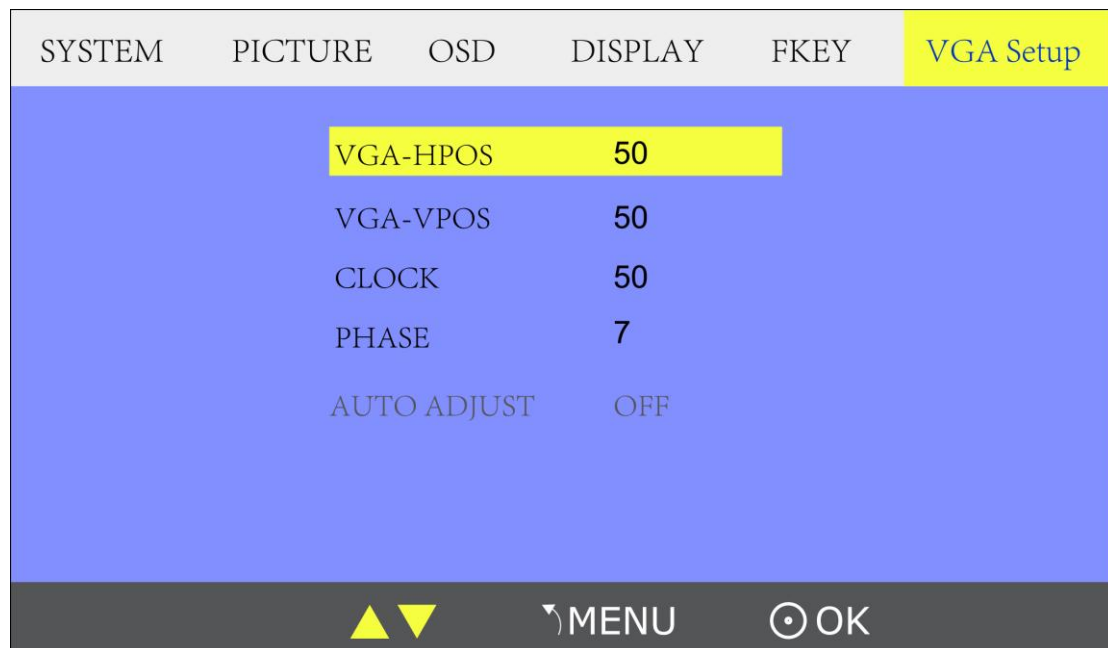

Enter to "VGA Setup" submenu to adjust VGA-HPOS (0~100), VGA-VPOS (0~100), CLOCK (0~100), PHASE (0~100). Also can select "ON" at "AUTO ADJUST" to adjust when input VGA signal.

4. System Setup and Operation

In This Chapter

This chapter focuses on system setup and operation, mainly including the following contents:

- [How to Turn On/Off the Monitor](#)
- [How to Monitor Audio](#)
- [How to Choose the Signal](#)
- [How to Use User Defined Function Key](#)
- [How to Display Aspect Ratio](#)
- [How to Display Current Settings](#)

How to Turn On/Off the Monitor

1. Plug in the power cord.
2. Press "POWER" key, key light lights, about 10 seconds later, the monitor begins to work.
3. Press "POWER" key again, key light goes out, the monitor is in standby state.
4. Disconnect the power, the monitor is turned off.

The monitor will memory the state before shutdown, and will keep the state when startup the computer next time.

Note

Disconnect with power cable if the monitor will not be used for a period of time.

How to Monitor Audio

First, ensure the monitor power on and in normal operation.

Specific operations as follows:

1. Press "SOURCE" key, and push "OK" rotary to choose signal.

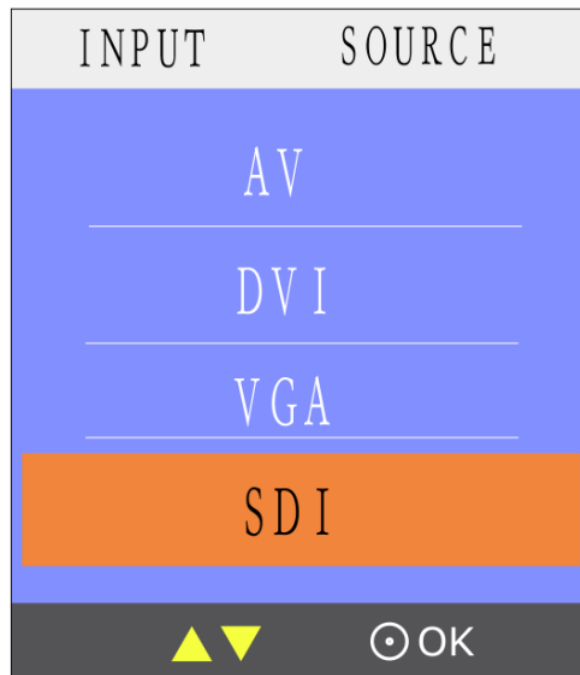

2. Press "OK" key to ensure the selected signal, can monitor HDMI (supported by DVI input) embedded audio.
3. Press "OK" key again, (or wait for about 5 seconds when out of menu system), push "OK" rotary to choose the desired volume.



How to Choose the Signal

First, ensure the monitor power on and in normal operation.

Specific operations as follows:

1. Press "SOURCE" key, and LCD screen displays as follows:

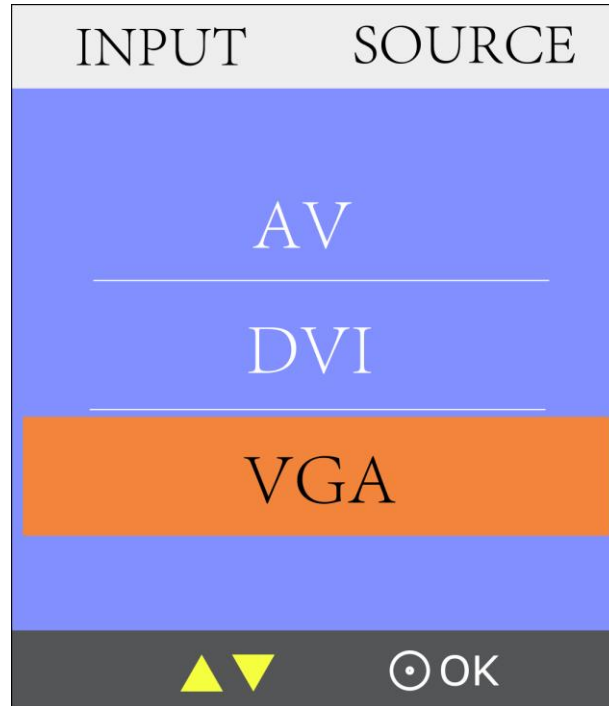

2. Push "OK" rotary to choose signal, AV, DVI, VGA, SDI (SDI is optional module) are available.
3. Press "OK" key to ensure the selected signal.

How to Use User Defined Function Key

First, ensure the monitor power on and in normal operation.

Specific operations as follows:

1. Enter to "MENU", press "FKEY" key:

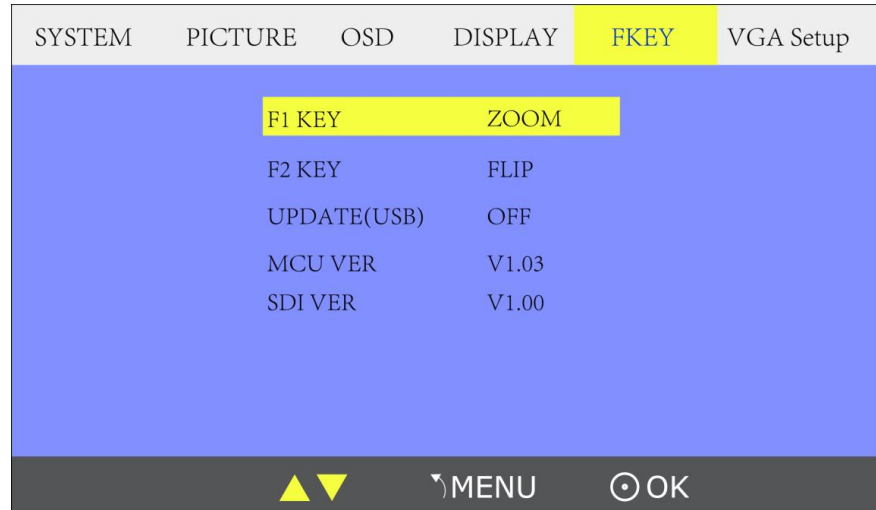

2. Choose "F1 KEY" or "F2 KEY".
3. Press "OK" key to ensure.
4. Push "OK" rotary to choose items.

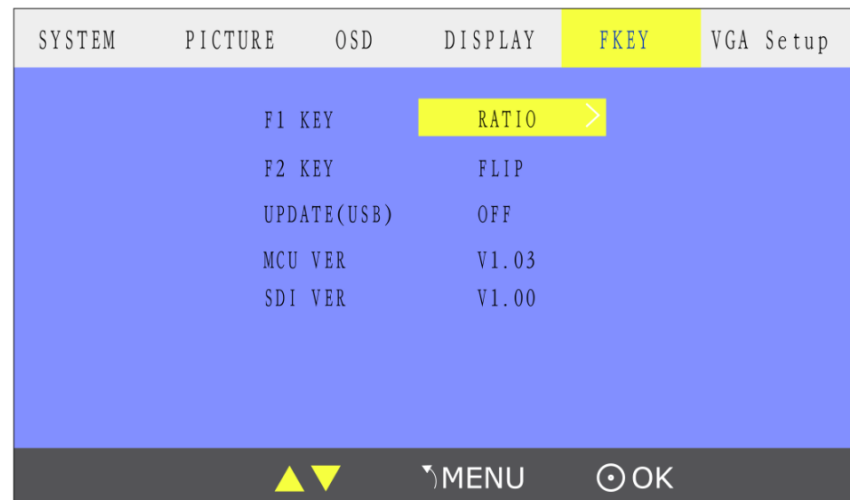

5. Press "OK" key to ensure.

How to Display Aspect Ratio

First, ensure the monitor power on and in normal operation.

Specific operations as follows:

1. Press "RATIO" key.
2. Push "OK" rotary to choose the aspect ratio, aspect ratio has two options, 16:9 and 4:3.



3. Press "OK" key to ensure.

How to Display Current Settings

1. First, ensure the monitor power on and in normal operation.
2. Press "DISPLAY" key, the LCD screen displays the current input signal information, including:

VGA

RATIO

SCAN

MARKER

FLIP

ZOOM

As shown below:

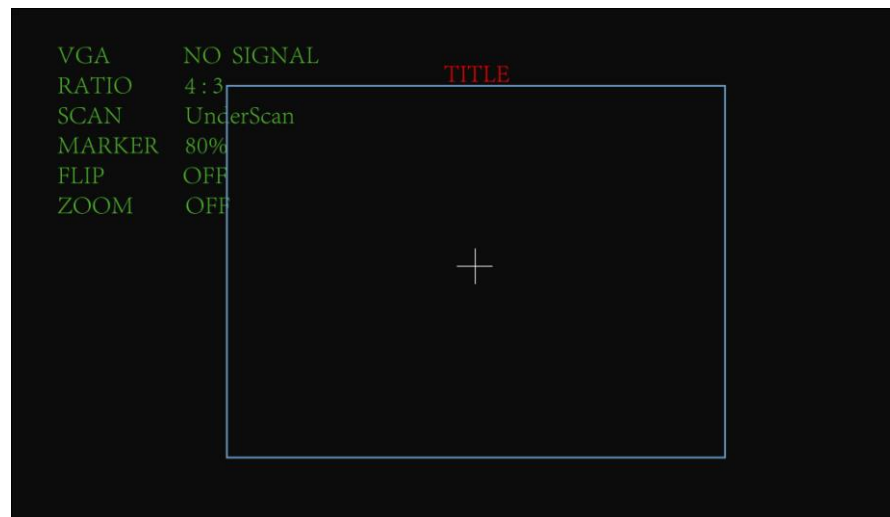

5. TALLY Light Operation

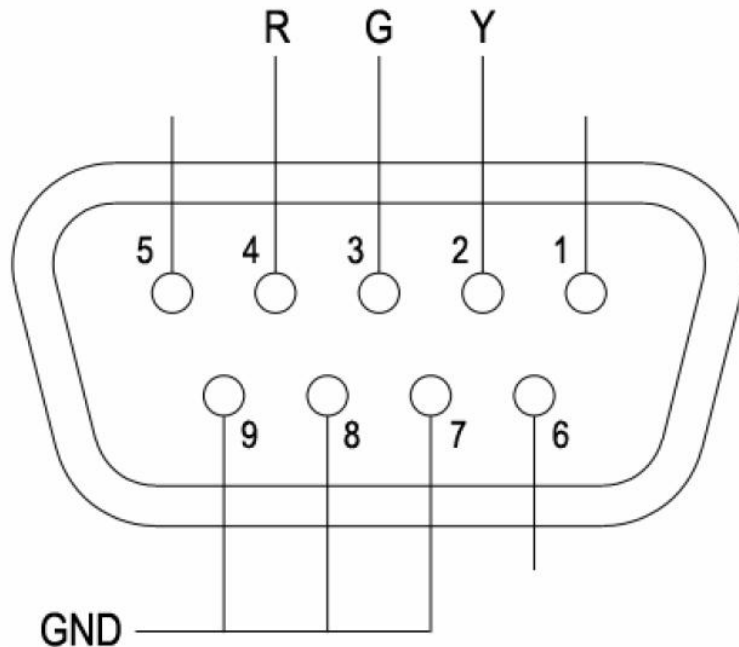

Terminal	1	2	3	4	5	6	7	8	9
Description		Y	G	R			GND	GND	GND

1. There are front TALLY lights on each of the display units, which can display RED, GREEN and YELLOW signals.
2. The TALLY light controlling port is the RS232 socket at the rear panel, and terminal description as above.
3. The RED light is on when connecting the terminal "R" with "GND", and goes out when disconnecting.
4. The GREEN light is on when connecting the terminal "G" with "GND", and goes out when disconnecting.
5. The YELLOW light is on when connecting the terminal "Y" with "GND", and goes out when disconnecting.

A. Specification



LCD Performance		
Size	5.0 inches x3	
Resolution	800xRGBx480	
Color	4677 million colors	
Aspect ratio	16:9 / 4:3	
Brightness	350cd/m ²	
Contrast	500:1	
Viewing angle	Horizontal /Vertical:140°/120°	
Video Format		
CVBS	NTSC / PAL	
SDI	SMPTE-425M	1080p (60 / 59.94 / 50)
	SMPTE-274M	1080i (60 / 59.94 / 50)
		1080p (30 / 29.97 / 25 / 24 / 23.98)
	SMPTE-296M	720p (60 / 59.94 / 50)
	SMPTE-125M	480i (59.94)
	ITU-R BT.656	576i (50)
DVI	480i / 576i / 480p / 576p	
	1080i (60 / 59.94 / 50)	
	720p (60 / 59.94 / 50)	
	1080p (60 / 59.94 / 50 / 30 / 29.97 / 25 / 24 / 23.98)	
VGA	800x600@60Hz	
	1024x768@60Hz	
	1024x768@75Hz	
	1280x720@60Hz	
	1280x768@60Hz	
	1280x800@60Hz	
	1280x1024@60Hz	
	1360x768@60Hz	
	1366x768@60Hz	
	1400x1050@60Hz	
	1440x900@60Hz	
	1600x1200@60Hz	
	1680x1050@60Hz	

	1920x1080@60Hz
General	
Working voltage	DC 12V
Power consumption	≤24W
Working temperature	0°C~+40°C
Working humidity	10%~90%
Storage temperature	-15°C~+60°C
Storage humidity	10%~90%
Dimensions	480X130X42mm
Net weight	2100g

B. Contact Information



Warranty:

All video products are designed and tested to the highest quality standard and backed by a full 3-year parts and labor warranty. Warranties are effective upon delivery date to customer and are non-transferable. RGBlink warranties are only valid to the original purchase/owner. Warranty related repairs include parts and labor, but do not include faults resulting from user negligence, special modification, lighting strikes, abuse(drop/crush), and/or other unusual damages.

The customer shall pay shipping charges when unit is returned for repair.

Headquarter: S603~604 Weiye Building Torch Hi-Tech Industrial Development Zone Xiamen, Fujian Province, P.R.C

C. RMS 5533 Optional Module: SDI Input Module

SDI is the optional module for RMS 5533 Rack Mount Monitor, it can be installed based on user's requirements.

The following is the picture of SDI input module:

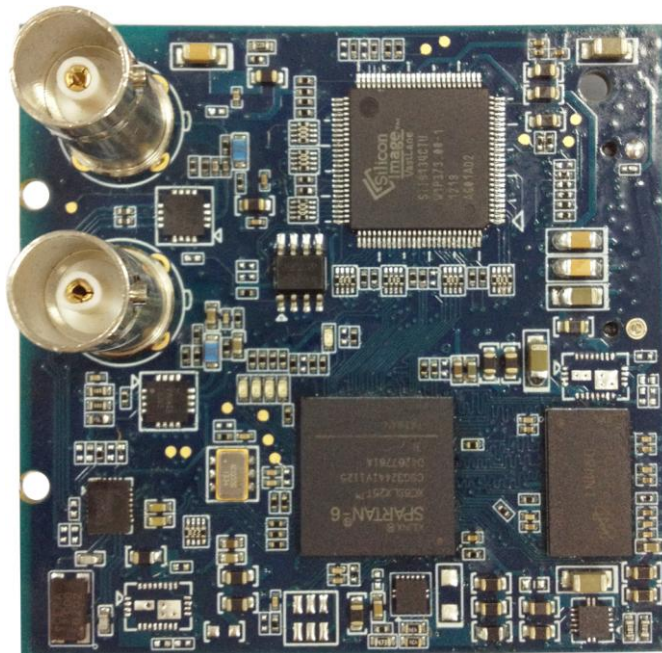

Specific installation steps are as follows:

Step 1: Unscrew the screw above the rear panel with the screwdriver, take the rear panel apart.



Step 2: Take three circuit boards inside apart respectively, the red box in circuit board is the area for SDI input module installation.



Step 3: Install the SDI input module in the area as shown above, then tighten the screws, install it one by one.

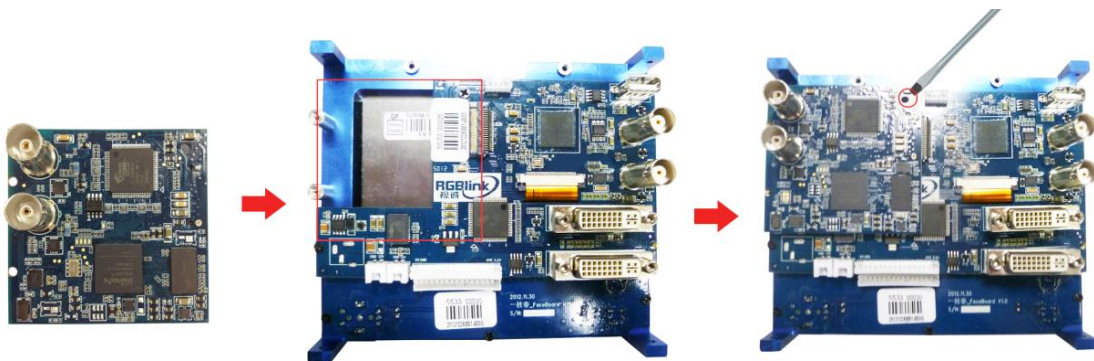

Step 4: When SDI input module installation complete, assemble the three circuit boards.



Step 5: Lock the rear panel, adding SDI input module finished.

