

SUPERSONIC®

Audio

INSTRUCTION MANUAL



SC-709CD

Before connection operating or adjusting this product
Please read these instructions completely
Please keep this manual.

Know these safety symbols



This "bolt of lightning" indicates uninsulated material within your unit which may cause an electrical shock. For the safety of everyone in your household, please do not remove product covering.



The "exclamation point" calls attention to features for which you should read the enclosed literature closely to prevent operating and maintenance problems.

Dripping warning:

The product shall not be exposed to dripping or splashing liquids and objects filled with liquids, such as vases, cups shall not be placed on the product.

For Customer Use
Enter below the Serial No. which is located
On the bottom of the cabinet. Retain this
Information for future reference.

Model No.: _____
Serial No.: _____

**WARNING: TO PREVENT
FIRE OR SHOCK HAZARD, DO
NOT EXPOSE THIS EQUIPMENT TO
RAIN OR MOISTURE.**

CAUTION: TO PREVENT
ELECTRIC SHOCK, MATCH WIDE
BLADE OF PLUG TO WIDE SLOT,
AND FULLY INSERT.

Ventilation warning:

The normal ventilation of the
product shall not be impeded for
intended use.

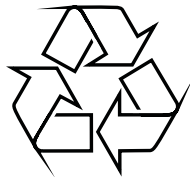

PREPARATION FOR USE

Unpacking and Setup

- * Carefully remove the unit from the display carton and remove all packing material from the unit itself.
- * Remove any descriptive labels that may be found on either the front or top cabinet of the unit. Do not Remove any labels located on either the back or in front cabinet of the unit.
- * Press the CD door OPEN Button to open the CD compartment door. There is a white card in the CD Compartment which is intended to prevent the Laser pickup from moving during shipment of the product,

Power Supply

Using AC power

1. Check if the power voltage, as shown on the type plate located on the bottom of the set, corresponds to your local AC power supply. If it does not, consult your dealer or service centre.
 2. Connect the power cord to the AC socket and then plug it into the socket. the power supply is now connected and ready for use.
 3. To switch off completely, unplug the power cord from the wall socket.
- Unplug the power cord from the wall outlet to protect your set during heavy thunderstorms.

Batteries (not included)

Open the battery compartment and insert eight batteries, type LR14, UM-2 or C-cells, (preferably Alkaline) with the correct polarity as indicated by the + and - symbols inside the compartment. The Batteries contains chemical substances, so they should be disposed of properly. Incorrect use of batteries can cause electrolyte leakage and will corrode the compartment and cause the batteries to burst. Therefore:

- Do not mix battery types: e.g. alkaline with carbon Zinc. Only use batteries of the same type for the set.
- When inserting new batteries, do not try to mix old batteries with new ones.
Remove the batteries if the set is not being used for a long time.

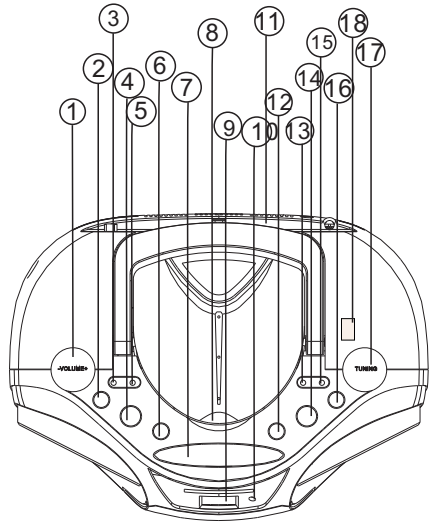

- 1.VOLUME CONTROL
- 2.EQ BUTTON
- 3.PRE-DN BUTTON
- 4.FUNCTION BUTTON
- 5.PRE-UP BUTTON
- 6.POWER BUTTON
- 7.CASSETTE RECORDERS KEYS
- 8.CD LID
- 9.LCD DISPLAY
- 10.STANDBY INDICATOR
- 11.FM ANTENNA
- 12.REPEAT BUTTON
- 13.STOP BUTTON
- 14.TIME/PROG. BUTTON
- 15. PLAY/ PAUSE BUTTON
- 16. MUTE BUTTON
- 17. TUNING/SKIP-/SKIP+ BUTTON
- 18.USB JACK

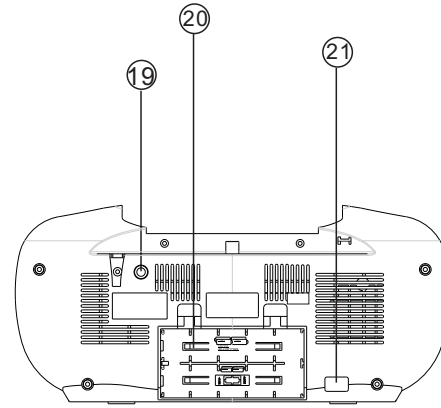

- 19.AUX JACK
- 20.BATTERIES COMPARTMENT
- 21.AC SOCKET

Remote Control

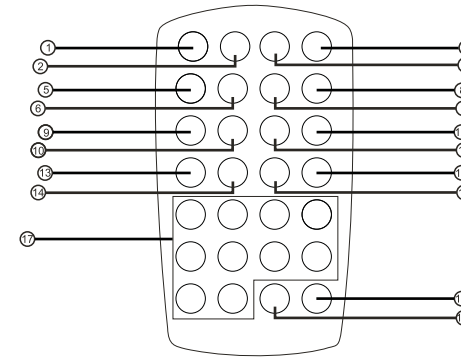

- 1.POWER BUTTON
- 2.BAND BUTTON
- 3.INTRO BUTTON
- 4.MUTE BUTTON
- 5.RANDOM BUTTON
- 6.P-UP BUTTON
- 7.REPEAT/MO/ST BUTTON
- 8.TIME/PROGRAM BUTTON
- 9.BACK BUTTON
- 10.FUNCTION BUTTON
- 11.NEXT BUTTON
- 12.EQ BUTTON
- 13.PLAY/PAUSE BUTTON
- 14.P-DOWN BUTTON
- 15.BBS BUTTON
- 16.STOP BUTTON
- 17.NUMBER KEY
- 18.VOL-BUTTON
- 19.VOL+BUTTON

- * Please pull out the plastic paper from the battery door before use the remote control.
 - * When the remote control operation becomes unstable or the distance from which the remote control works is shorter . Replace the batteries with new ones.
 - * Using the remote control unit
- To use the remote unit, point at the REMOTE SENSOR and press the buttons gently and firmly. Remote control operation is possible within approximate 18ft(6m). However, since the remote control range is less when the unit is used at an angle, use directly in front of the REMOTE SENSOR , for maximum distance.
- Do not expose the REMOTE SENSOR to strong light(direct sunlight or artificial lighting)and make sure that there are no obstacles between the REMOTE SENSOR and the remote control unit.

Top and front panels(see 1)**1.VOLUME BUTTON**

- Press the VOLUME button mark place adjust volume level..

2.EQ BUTTON

-Press the button to change EQ CD/MP3/USB/AUX/RADIO's music style.

-When playing the music, Press this button is in the popular-jazz-FLR-classica-rock.

3. PRE-DN BUTTON

- In the radio mode, press PRE-DN button mark to choose the back channel.

- In the mp3 mode, press PRE-DN button mark to enter the back folder.

4. FUNCTION SELECT

- Select source of sound CD/USB/AUX/TAPE/RADIO.

5.PRE-UP BUTTON

-In the radio mode, press PRE-UP button mark to choose the next channel.

-In the mp3 mode, press PRE-UP button mark place enter into the next folder.

6.POWER BUTTON

-Press POWER button to turn on/off power.

7.CASSETTE RECORDERS KEYS

RECORD (●) - start recording

PLAY (◀) - start playback

F.FWD (◀◀) -rewind the tape toward the beginning.

F.REW (▶▶) -advance the tape toward the end.

STOP/EJECT (■▲) - stop the tape

- open the cassette compartment

PAUSE (⏸) - interrupt recording or playback

8. CD DOOR OPEN/CLOSE BUTTON

- Press here to open/close the CD door.

9. LCD DISPLAY

- Show the FM dial frequency.

- Show the number of tracks.

- Show the time.

10. STANDBY INDICATOR**11.FM ANTENNA**

-To improve FM reception.

12.REPEAT BUTTON

- Repeat a track CD/MP3/USB program.

- Repeat mode : repeat ->repeat all-> repeat album ->normal

13.STOP BUTTON

- Stop CD/MP3/USB playback; erase a CD program.

14.TIME/PROGRAM BUTTON

-In standby mode, to setup the time of the unit.

-Program and review programmed track numbers.

-In the working mode, press this button can for CD/MP3/USB/RADIO for programming.

15.PLAY/PAUSE BUTTON

- Start or pause MP3/CD/USB playback.

- In the radio mode, press this button you will enter in the low end of the manual channel scan mode.

16.MUTE BUTTON

Press the mute button allows CD/MP3/USB AUX/the RADIO to enter the mute state.

17.TUNING/SKIP-/SKIP+ BUTTON**BACK KNOB**

-BACK track selection.

-Rotate and hold more than 1.5 sec BACK search intra track.

-In the radio mode, rotate BACK will enter the low end of the manual channel scan mode.

NEXT KNOB

-NEXT track selection.

-Rotate and hold more than 1.5 sec forward search intra track.

-In the radio mode, rotate NEXT will enter the high-end manual channel scan mode.

18.USB JACK

-To listen to your USB with Mp3 music files.

19.AUX JACK

-Press FUNCTION button , select AUX station.

Play Mp3, DISCMAN,WALKMAN AUX

insert when no disc.

NOTE: please take out the CD disc.

20.BATTERY DOOR

-To open battery compartment.

21. AC SOCKET

- Inlet for power cord.

Radio reception

1.Press FUNCTION button select RADIO mode.

2.Tune to required station by press BACK、NEXT or PRE-UP、PRE-DN button.

Manual Tuning: Press BACK or NEXT button and then release within 1 sec.

Auto Tuning: Press the PLAY/PAUSE button enter the automatic channel surfing mode, and to be put automatically sets.

reset Channel:(FM 30 Preset memories)

(1) Press BACK or NEXT button to select desired station.

(2) Press PROGRAM button once , The MEMORY number indicator begins fixed in the display.

(3) Press PRESET-UP OR PRESET DOWN buttons to select the desired number.

(4) Press PROGRAM button to save that station.

(5) Repeat steps (1) to (4) procedures for other stations.

3.After end of program. Press PRE-UP or PRE-DN to start play the frequency that you selected or Press number key on the remote control .

4.Press [VOL-]or [VOL +] to adjust the volume.

5.Extend TELESCOPIC ANTENNA to its full length if you are listening to FM broadcasting.

6. Turn off the radio by pressing the FUNCTION button select another mode or press the power button to turn off the unit.

7. The memory frequency still exists , after switching back on the unit.

USE AUX

To listen to music with a mp3, discman, walkman.

- 1.Connect to the AUX .
 - 2.Press function button selector to AUX, the sound source of the mp3 or discman or walkman will output through the unit.
- Press the volume control to adjust the volume.
 - The external unit not can control the player.

USING THE CASSETTE

UNDERSTANDING THE BUTTONS

RECORD - Press to record from the radio or CD play.

PLAY - Press to play cassettes.

REW - From stop mode, press to rewind the tape toward the beginning.

F.FWD - From stop mode, press to advance the tape toward the end.

STOP/EJ. - Press to stop current tape activity or to open the cassette compartment door when no buttons are active.

PAUSE - Press to interrupt tape play or record mode, press the second time to resume tape play or tape record mode.

HOW TO PLAY A CASSETTE TAPE

- 1.Press FUNC button select TAPE mode.
 - 2.Press STOP/EJ.key to open the cassette compartment door.
 - 3.Insert a recorded cassette and close the cassette compartment door.
 - 4.Press PLAY to start playback.
 - 5.To interrupt playback, press PAUSE ,To resume, press the key again.
 - 6.Press REW/F.FWD to move tape to the desired starting point.
 - 7.Adjust the volume to your desired listening level.
 - 8.To stop the tape ,press STOP/EJ.
- The keys are automatically released at the end of the tape, except if PAUSE has been activated.

RECORDING FROM THE RADIO

- 1.Tune to the desired radio station.
- 2.Press STOP/EJ. To open the cassette door.
- 3.Insert a suitable cassette into the cassette deck and close the cassette door.
- 4.Press RECORD to start recording. RECORD key and PLAY key go down simultaneously.
- 5.For brief interruptions ,press PAUSE .To resume recording, press PAUSE again.
- 6.To stop recording , press STOP/EJ.
- 7.To hear what you have recorded, follow the instructions in how to PLAYING a cassette tape.

RECORDING FROM CD

- 1.Insert a blank tape into the tape deck.
- 2.Press CD button on.
- 3.Load a CD disc into disc compartment and select the desire track you want to record.
- 4.Press DISC PLAY/PAUSE button to play the desired track(passage)
- 5.Press RECORD key and the PLAY key will automatically engage.
- 6.Press PAUSE key to interrupt or edit recording. Press it again to resume recording.
- 7.Press STOP/EJ. Key to end recording.
- 8.To hear what you have recorded, follow the instructions in how to PLAY A CASSETTE TAPE

PROGRAM METHOD

- (1)Press the [PROGRAM] key at STOP mode, system will go to PROGRAM mode.
 - The PRG icon and P01 will blink. This prompts the user to enter the first songs in the program PLAY list.
- (2)The user can select the desire tracks by using [NEXT], [BACK] keys.
 - Once these keys are pressed, the Display will show the selected track.
- (3)After select the desired track, press [PROGRAM] key again and it will be stored in the memory.
 - Mp3 Maximum 99 and CD Maximum 20 tracks can be programmed when Repeat steps (2) to (3) procedures.
- (4)If press the [STOP] key during the program mode, then the selected TRACKS will be stored in the memory and return to STOP mode (Continuous Play mode)
- (5)If press the [PLAY] key during the program mode, it will start the program PLAY mode.
 - PLAY start from P01 Track

Erasing a program

You can erase the content of the memory by:

- While playing, press STOP button twice.
- Opening the CD door
- Select the other mode.

CD/MP3 PLAYER

CD/MP3 Player

Playing a CD/MP3

This CD-player can play Audio Discs, MP3 CD-R. Do not try to play CD-ROM, CDi, VCD, DVD or computer CD.

1. Press function button to CD state.
2. To open the cd door, press cd open button.
3. Insert a mp3/cd or cd-r, with the printed side facing up and press cd door gently to close.
4. Press play/pause on the set to start playback.
5. Press the pause button to pause play, press the play button back playing.
6. To stop cd playback, press stop.

note: cd/mp3 play will also stop when:

- you open the cd compartment;
- you select radio sound source;
- the cd/mp3 has reached to the end.

Selecting a different track.

During playback you can use back or next to select a particular track.

If you have selected a track number in the stop or pause position, press play to start playback.

Press next once briefly for the next track, or press repeatedly until the desired track number appears in the display.

Press back once briefly to return to the beginning of a current track.

Press back more than once briefly for a previous track.

-Finding a song within a track

1. Press and key hold down back or next. the cd is played at high speed.
2. When you recognize the song you want release back or next. normal playback resumes.

different play modes: repeat

- Repeat-play the current track continuously.
- Repeat all-plays the entire cd continuously.

Playing tracks in random order after press the random button, the tracks will be played in random order.

Playing a USB

Playing a USB

USB Audio functions

- 1) Press function button or stop usb button to choose the usb state.
- 2) PLAY/PAUSE
- 3) NEXT, BACK Skip search
- 4) Program Track (MP3 99 Track CD 20 Track)
- 5) REPEAT MODE : repeat 1->repeat all-> repeat album ->normal
- 6) Maximum Folder : 99 Folders
- 7) Maximum File : 999 Files

*Notice :

- When the unit has not the disc, and plug a usb card in the unit. The unit will automatically play the usb card,
- The unit don't support the HDD all and the portion usb with mp3 player.

Note: at the mode of CD/MP3 / USB, the lcd will show display the number of song or the song playing time.

RECORDING

GENERAL INFORMATION ON RECORDING

*Recording is permissible in so far as copyright or other rights of third parties are not infringed.

*This deck is not suitable for recording on CHROME (IEC II) or METAL (IEC IV) type cassette. For Recording, use NORMAL type cassettes (IEC I) on which the tabs have not been broken.

The best recording level is set automatically, Altering the VOLUME controls will not affect the recording in progress.

*To protect a tape from accidental erasure, have the tape in front of you and break out the left tab. Recording on this side is no longer possible. To record over this side again, cover the tabs with a piece of adhesive tape.

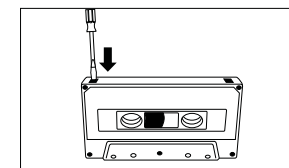

MAINTENANCE

Tape deck maintenance

To ensure quality recording and playback of the tape deck, clean parts A, B and C shown in the diagram below, after approx. 50 hours of operation, or on average once a month, use a cotton bud slightly moistened with alcohol or a special head cleaning fluid to clean the deck.

- 1, Open the cassette door by pressing STOP*EJECT.
- 2, Press PLAY and clean the rubber pressure rollers C
- 3, Press PAUSE and clean the magnetic heads A and also the Capstan B
- 4, After cleaning, press STOP*EJECT.

Note: Cleaning of the heads can also be done by playing a cleaning cassette through once.

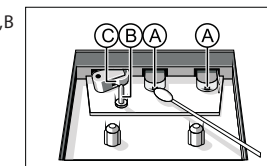

MAINTENANCE & SAFETY

Precautions & General Maintenance

- Place the set on a hard and flat surface so that the system does not tilt.
- Do not expose the set, batteries or CDs to humidity, rain, sand or excessive heat caused by heating equipment or direct sunlight.
- Do not cover the set. Adequate ventilation with a minimum gap of 6 inches between the ventilation holes and surrounding surfaces is necessary to prevent heat build-up.
- The mechanical parts of the set contain self-lubricating bearings and must not be oiled or lubricated.
- To clean the set, use a soft dry cloth. Do not use any cleaning agents containing alcohol, ammonia, benzene or abrasives as these may harm the housing.

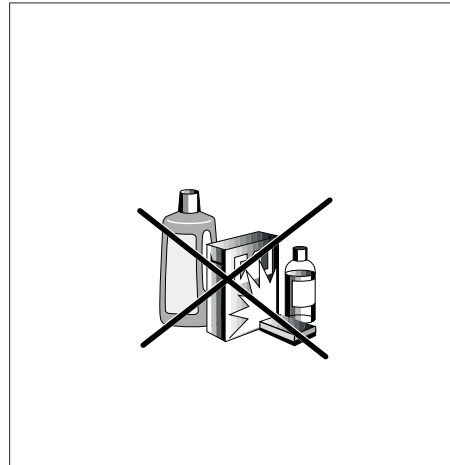

CD player and CD handling

- The lens of the CD player should never be touched!
- Sudden changes in the surrounding temperature can cause condensation to form and the lens of your CD player to cloud over. Playing a CD is then not possible. Do not attempt to clean the lens but leave the set in a warm environment until the moisture evaporates.
- Always close the CD door to keep the CD compartment dust-free. To clean, dust the compartment with a soft dry cloth.
- To clean the CD, wipe in a straight line from the centre towards the edge using a soft, lint-free cloth. Do not use cleaning agents as they may damage the disc.
- Never write on a CD or attach any stickers to it.

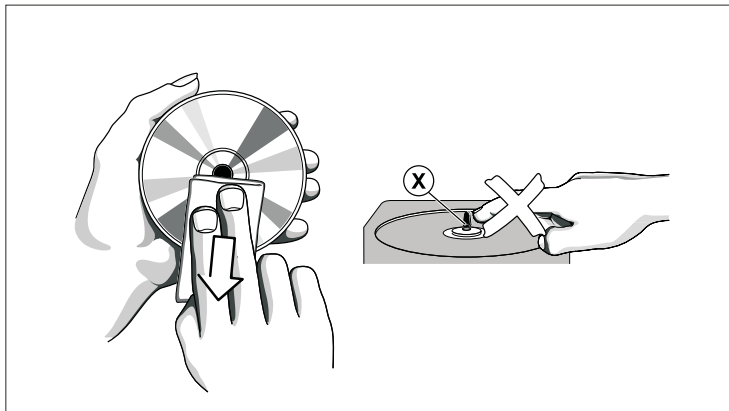

TROUBLESHOOTING

TROUBLESHOOTING

Troubleshooting

If a fault occurs, first check the points listed below before taking the set for repair.

Do not open the unit as there is a risk of electric shock.

If you are unable to remedy a problem by following these hints. Consult your dealer or service center.

WARNING: Under no circumstances should you try to repair the set yourself, as this will invalidate the warranty.

--Problem and Solution:

No sound.

Volume not adjusted

No Power

- Power cord not securely connected
- Connect the AC power cord properly
- Batteries dead/incorrectly inserted
- Insert (fresh) batteries correctly

Display does not function properly

Any reaction to operation of any of the controls:

- Electrostatic discharge
 - Switch off and unplug the set. Reconnect after a few seconds

Poor cassette sound quality

- Dust and dirt on the heads, etc.
- *Clean deck parts etc, see Maintenance
- Use of incompatible cassette types (METAL or CHROME)
- *Only use NORMAL (IEC I) for recording

Recording does not work

- Cassette tabs may be broken
- *Apply a piece of adhesive tape over the missing tab space

Environmental information

We have done our best to reduce the packaging and make it easy to separate into 3 materials: Cardboard, paper pulp and expandable polyethylene.

Your set consists of materials which can be recycled if disassembled by a specialized company. Please observe the local regulations regarding the disposal of packaging, dead batteries and old equipment..

CD/MP3/USB playback does not work

- CD/MP3/USB badly scratched/dirty
- Replace/clean CD/MP3/USB (see maintenance)

The CD/MP3 skips tracks

- CD/MP3 damaged or dirty
- Replace or clean CD/MP3
- Program is active, quit program mode.

CD badly scratched or dirty

- Replace/clean CD, see Maintenance

no disc indication

- CD-R, is blank or the disc is not finalized
- Use a finalized CD-R.