



RETAIN THESE INSTRUCTIONS
FOR FUTURE REFERENCE

INSTALLATION INSTRUCTIONS

STANDARD SERIES

36" B-VENTED GAS APPLIANCES
P/N 700,003M REV. H 05/2004

MODELS

Millivolt Models
B-40RMN
B-40RMP

Electronic Models
B-40REN
B-40REP

This appliance may be installed in an after-market permanently located, manufactured home (USA only) or mobile home, where not prohibited by local codes. This appliance is only for use with the type of gas indicated on the rating plate. This appliance is not convertible for use with other gases, unless a certified kit is used.

WARNING: IF THE INFORMATION IN THIS MANUAL IS NOT FOLLOWED EXACTLY, A FIRE OR EXPLOSION MAY RESULT CAUSING PROPERTY DAMAGE, PERSONAL INJURY OR LOSS OF LIFE.

FOR YOUR SAFETY: Do not store or use gasoline or other flammable vapors or liquids in the vicinity of this or any other appliance.

FOR YOUR SAFETY: What to do if you smell gas:

- DO NOT light any appliance.
- DO NOT touch any electrical switches.
- DO NOT use any phone in your building.
- Immediately call your gas supplier from a neighbor's phone. Follow your gas suppliers instructions.
- If your gas supplier cannot be reached, call the fire department.

Installation and service must be performed by a qualified installer, service agency or the gas supplier.

AVERTISSEMENT: ASSUREZ-VOUS DE BIEN SUIVRE LES INSTRUCTIONS DONNÉ DANS CETTE NOTICE POUR RÉDUIRE AU MINIMUM LE RISQUE D'INCENDIE OU POUR ÉVITER TOUT DOMMAGE MATÉRIEL, TOUTE BLESSURE OU LA MORT.

POUR VOTRE SÉCURITÉ: Ne pas entreposer ni utiliser d'essence ni d'autre vapeurs ou liquides inflammables dans le voisinage de cet appareil ou de tout autre appareil.

POUR VOTRE SÉCURITÉ: Que faire si vous sentez une odeur de gaz:

- Ne pas tenter d'allumer d'appareil.
- Ne touchez à aucun interrupteur. Ne pas vous servir des téléphones se trouvant dans le bâtiment où vous vous trouvez.
- Evacuez la pièce, le bâtiment ou la zone.
- Appelez immédiatement votre fournisseur de gaz depuis un voisin. Suivez les instructions du fournisseur.
- Si vous ne pouvez rejoindre le fournisseur de gaz, appelez le service des incendies.

L'installation et service doit être exécuté par un qualifié installateur, agence de service ou le fournisseur de gaz.



WH Report No. J20006722

TABLE OF CONTENTS

Introduction	page 2
General Information	page 2
Location	page 3
Clearances	page 3
Appliance Specifications	page 4
Gas Vent Rule	page 4
Framing Specifications	page 5
Typical Installation Sequence	page 5
Installation	page 5
Vent System Installation	page 6
Field Wiring	page 7
Connecting Gas Line	page 7
Outside Air Kit Installation	page 8
Log and Rockwool Installation	page 9
Appliance Operation	page 9
Manual Limit Switch	page 9
Millivolt Appliance Checkout	page 10
Electronic Appliance Checkout	page 10
Adjustments	page 10
Finishing Requirements	page 11
Cold Climate Insulation	page 11
Installation Accessories	page 11
Gas Conversion Kits	page 12



We suggest that our gas hearth products be installed and serviced by professionals who are certified in the U.S. by the National Fireplace Institute® (NFI) as NFI Gas Specialists.

This installation manual will help you obtain a safe, efficient, dependable installation for your appliance and vent system.

Please read and understand these instructions before beginning your installation.

INTRODUCTION

The millivolt appliances are designed to operate on either natural or propane gas. A millivolt gas control valve with piezo ignition system provides safe, efficient operation.

The electronic appliances are designed to operate on either natural or propane gas. An electronic direct intermittent pilot system provides safe, efficient operation. External electrical power is required to operate these units.

These appliances comply with National Safety Standards and are tested and listed by Warnock Hersey (Report No. J20006722) to ANSI Z21.50 - 2000 (in Canada, CSA 2.22 - 2000), and CAN/CGA-2.17-M91 in both USA and Canada, as vented gas fireplaces.

Installation must conform to local codes. In the absence of local codes, installation must comply with the current National Fuel Gas Code, ANSI Z223.1 (NFPA 54). (In Canada, the current CAN/CGA B149 installation code.) Electrical wiring must comply with local codes. In the absence of local codes, installation must be in accordance with the National Electrical Code, NFPA 70 - (latest edition). (In Canada, the current CSA C22.1 Canadian Electric Code.)

DO NOT ATTEMPT TO ALTER OR MODIFY THE CONSTRUCTION OF THE APPLIANCE OR ITS COMPONENTS. ANY MODIFICATION OR ALTERATION MAY VOID THE WARRANTY, CERTIFICATION AND LISTINGS OF THIS UNIT.

WARNING: IMPROPER INSTALLATION, ADJUSTMENT, ALTERATION, SERVICE OR MAINTENANCE CAN CAUSE INJURY OR PROPERTY DAMAGE. REFER TO THIS MANUAL. FOR ASSISTANCE OR ADDITIONAL INFORMATION CONSULT A QUALIFIED INSTALLER, SERVICE AGENCY OR THE GAS SUPPLIER.

GENERAL INFORMATION

Note: Installation and repair should be performed by a qualified service person. The appliance should be inspected annually by a qualified professional service technician. More frequent inspections and cleanings may be required due to excessive lint from carpeting, bedding material, etc. It is imperative that the control compartment, burners and circulating air passage ways of the appliance be kept clean.

S'assurer que le brûleur et le compartiment des commandes sont propres. Voir les instructions d'installation et d'utilisation qui accompagnent l'appareil.

Provide adequate clearances around air openings and adequate accessibility clearance for service and proper operation. Never obstruct the front openings of the appliance.

WARNING: THESE FIREPLACES ARE VENTED DECORATIVE GAS APPLIANCES. DO NOT BURN WOOD OR OTHER MATERIAL IN THESE APPLIANCES.

These appliances are designed to operate on natural or propane gas only. The use of other fuels or combination of fuels will degrade the performance of this system and may be dangerous.

Input of appliance is 15,000 BTU/HR.

Gas Type	Orifice Size	Elevation
Natural	#49 (.073)	0 - 4500' (0 - 1370 m)
Propane	(.045)	0 - 4500' (0 - 1370 m)

Nominal operating pressures for the manifold side of the gas control system are; 3.5 inches water column (0.87 kPa) for natural gas models and 10 inches water column (2.49 kPa) for propane gas models.

Do not use these appliances if any part has been under water. Immediately call a qualified, professional service technician to inspect the appliance and to replace any parts of the control system and any gas control which have been under water.

Ne pas se servir de cet appareil s'il a été plongé dans l'eau, complètement ou en partie. Appeler un technicien qualifié pour inspecter l'appareil et remplacer toute partie du système de contrôle et toute commande qui ont été plongés dans l'eau.

This appliance may be installed in an aftermarket permanently located, manufactured home (USA only) or mobile home, where not prohibited by local codes. This appliance is only for use with the type of gas indicated on the rating plate. This appliance is not convertible for use with other gases, unless a certified kit is used. Cet appareil peut être installé dans un maison préfabriquée (É.-U. seulement) ou mobile déjà installée à demeure si les règlements locaux le permettent.

Cet appareil doit être utilisé uniquement avec les types de gaz indiqués sur la plaque signalétique. Ne pas l'utiliser avec d'autres gaz sauf si un kit de conversion certifié est installé.

Millivolt appliances may be fitted at time of manufacture with either a Honeywell millivolt gas control valve or as SIT millivolt gas control valve. Both valves have been tested with and approved for use with these appliances and are listed accordingly.

Test gage connections are provided on the front of the millivolt gas control valve (identified IN for the inlet and OUT for the manifold side). A 1/8" NPT test gage connection is provided at the inlet and outlet side of the electronic gas control valve.

Minimum inlet gas pressure to the appliance is 5.0 inches water column (1.24 kPa) for natural gas and 11 inches water column (2.74 kPa) for propane for the purpose of input adjustment.

Maximum inlet gas supply pressure to the appliance is 10.5 inches water column (2.61 kPa) for natural gas and 13.0 inches water column (3.23 kPa) for propane.

The appliance must be isolated from the gas supply piping system (by closing its individual manual shut-off valve) during any pressure testing of the gas supply piping system at test pressures equal to or less than 1/2 psig (3.5 kPa).

The appliance and its individual shut-off valve must be disconnected from the gas supply piping system during any pressure testing of that system at pressures in excess of 1/2 psig (3.5 kPa).

These appliances must not be connected to a chimney or flue serving a separate solid fuel burning appliance.

Do not place clothing or other materials on or near this appliance.

WARNING: FAILURE TO COMPLY WITH THE INSTALLATION AND OPERATING INSTRUCTIONS PROVIDED IN THIS DOCUMENT WILL RESULT IN AN IMPROPERLY INSTALLED AND OPERATING APPLIANCE, VOIDING ITS WARRANTY. ANY CHANGE TO THIS APPLIANCE AND/OR ITS OPERATING CONTROLS IS DANGEROUS. IMPROPER INSTALLATION OR USE OF THIS APPLIANCE CAN CAUSE SERIOUS INJURY OR DEATH FROM FIRE, BURNS, EXPLOSION OR CARBON MONOXIDE POISONING.

Carbon Monoxide Poisoning: Early signs of carbon monoxide poisoning are similar to the flu with headaches, dizziness and/or nausea. If you have these signs, obtain fresh air immediately. Turn off the gas supply to the appliance and have it serviced by a qualified professional, as it may not be operating correctly.

WARNING: B-VENT APPLIANCES ARE NOT DESIGNED TO OPERATE IN NEGATIVELY PRESSURED ENVIRONMENTS (PRESSURE WITHIN THE HOME IS LESS THAN PRESSURES OUTSIDE). SIGNIFICANT NEGATIVELY PRESSURED ENVIRONMENTS CAUSED BY WEATHER, HOME DESIGN, OR OTHER DEVICES MAY IMPACT THE OPERATION OF THESE APPLIANCES. NEGATIVE PRESSURES MAY RESULT IN POOR FLAME APPEARANCE, SOOTING, DAMAGE TO PROPERTY AND/OR SEVERE PERSONAL INJURY. DO NOT OPERATE THESE APPLIANCES IN NEGATIVELY PRESSURED ENVIRONMENTS.

WARNING: CHILDREN AND ADULTS SHOULD BE ALERTED TO THE HAZARDS OF HIGH SURFACE TEMPERATURES. USE CAUTION AROUND THE APPLIANCE TO AVOID BURNS OR CLOTHING IGNITION. YOUNG CHILDREN SHOULD BE CAREFULLY SUPERVISED WHEN THEY ARE IN THE SAME ROOM AS THE APPLIANCE.

WARNING: DO NOT PLACE CLOTHING OR OTHER FLAMMABLE MATERIALS ON OR NEAR THIS APPLIANCE.

AVERTISSEMENT: SURVEILLER LES ENFANTS. GARDER LES VÊTEMENTS, LES MEUBLES, L'ESSENCE OU AUTRES LIQUIDES À VAPEUR INFLAMMABLES LOIN DE L'APPAREIL.

WARNING: THIS APPLIANCE MAY ONLY BE FITTED WITH DOORS CERTIFIED FOR USE WITH THE APPLIANCE.

AVERTISSEMENT: POUR UTILISATION UNIQUEMENT AVEC LES PORTES EN VERRE CERTIFIÉES AVEC L'APPAREIL.

These appliances are equipped with an integral combustion air door and actuator arm. Combustion air kits are optional and must be installed before removing the securing screw allowing the movement of the combustion air actuator arm (*see Step 7*).

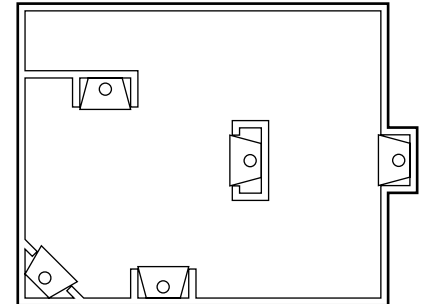

Typical Locations

Figure 1

LOCATION

In selecting the location, the aesthetic and functional use of the appliance are primary concerns. However, vent system routing to the exterior and access to the fuel supply are also important. Due to high temperatures the appliance should be located out of traffic and away from furniture and draperies. Consideration should be given to traffic ways, furniture, draperies, etc., due to elevated surface temperatures. The location should also be free of electrical, plumbing or other heating/air conditioning ducting.

The appliance should be mounted on a fully supported base extending the full width and depth of the unit. The appliance may be located on or near conventional construction materials. However, if installed on combustible materials, such as carpeting, vinyl tile, etc., a metal or wood barrier covering the entire bottom surface must be used.

These appliances may be used for bedroom installations in the United States and are listed accordingly. These units may not be installed in bedrooms in Canada.

CLEARANCES

Minimum clearance to combustibles for the appliance is as follows: sides and back - 0" (0 mm), floor - 0" (0 mm), adjacent wall - 0" (0 mm), ceiling - 64" (1626 mm).

APPLIANCE SPECIFICATIONS

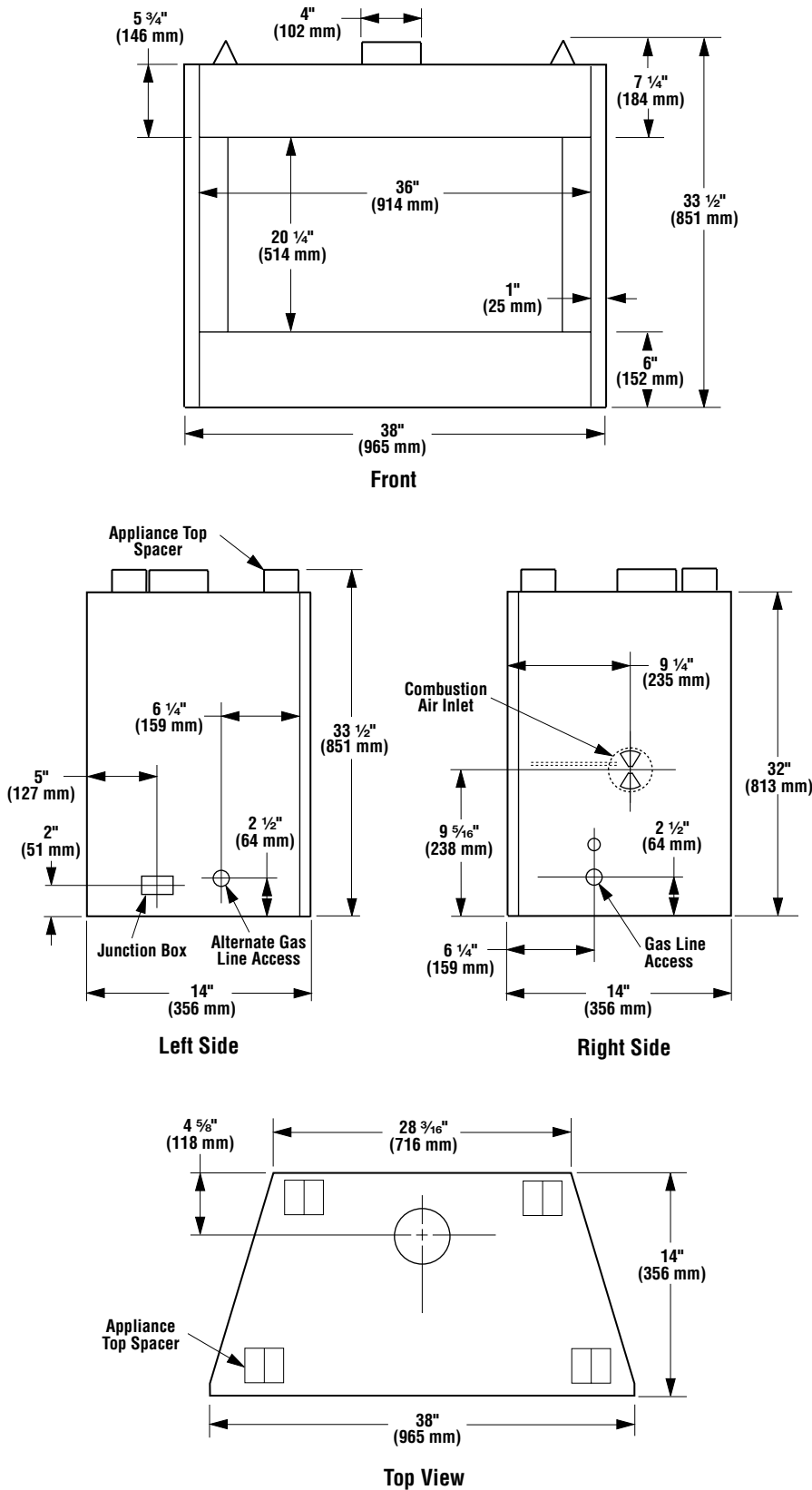

Figure 2

NOTE: DIAGRAMS & ILLUSTRATIONS NOT TO SCALE.

Venting

Gas Vent Rule – Gas vent caps are not permitted within 8 feet (2.4 mm) of a vertical wall or similar obstruction. Gas vent caps that are located 8' or more from a portion of a building which extends at an angle greater than 45° upward from the horizontal may terminate in accordance with Table 1 (**Figure 3**), provided that in no case shall any discharge opening on the cap be less than 2' (610 mm) horizontally from the roof surface (National Fuel Gas Code ANSI Z223.1 (NFPA 54) 7.6.2) (CAN/CGA B149).

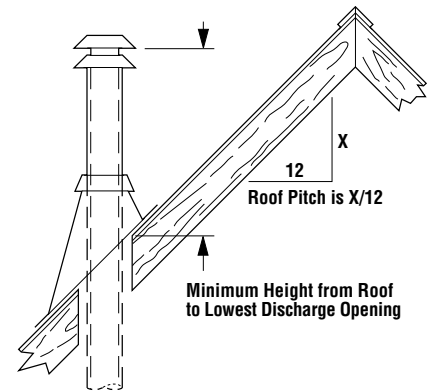

Figure 3

Roof Slope	Minimum Height from Roof to Lowest Discharge Opening	
	Feet	Meters
Flat to 6/12	1' 0"	0.3
Over 7/12 to 9/12	2' 0"	0.6
Over 10/12 to 12/12	4' 0"	1.2
Over 13/12 to 16/12	6' 0"	1.8
Over 17/12 to 21/12	8' 0"	2.4

Note: Venting terminals shall not be recessed into a wall or siding.

Table 1

Multiple Terminations – These appliances may vent adjacent to and at the same level with any other gas appliances (including direct-vent appliances) provided that there is at least 2 ft. (0.6m) between the proximal edges of the vent caps. These appliances may be vented adjacent to a chimney vent servicing a solid fuel fireplace provided the B-vent cap is at least 2 ft. (0.6m) away from the nearest point of the chimney opening.

FRAMING SPECIFICATIONS

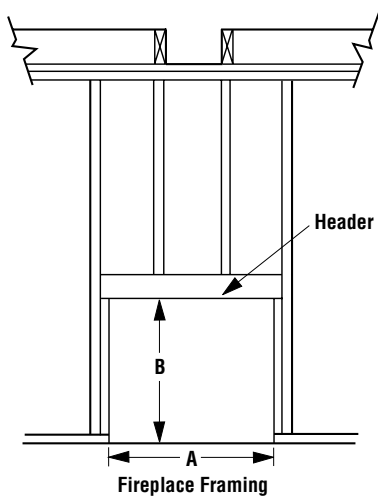

Figure 4

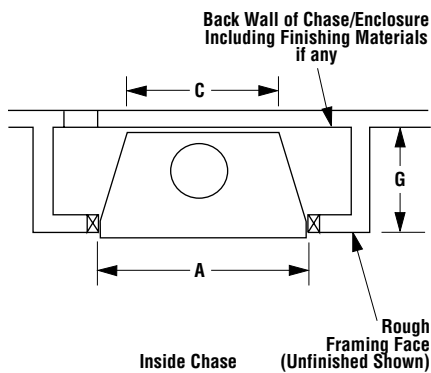

Figure 5

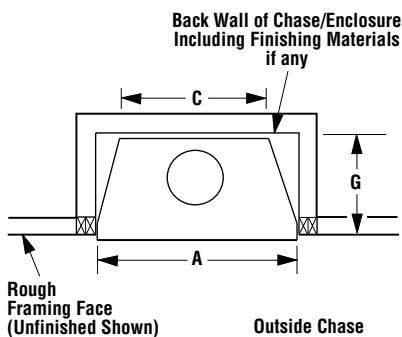

Figure 6

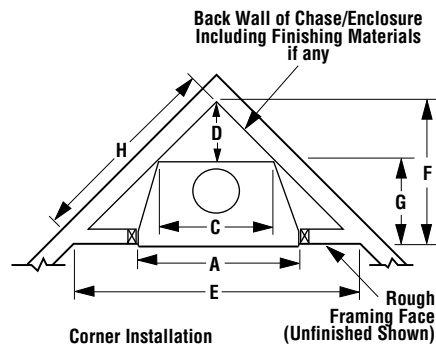

Figure 7

Framing Dimensions

A	38 1/2"	978 mm
B	33 3/4"	857 mm
C	28 3/16"	716 mm
D	14"	356 mm
E	55"	1397 mm
F	27 1/2"	699 mm
G	13 1/2"	343 mm
H	38 7/8"	987 mm

Note: All framing dimensions calculated for 1/2" dry wall at the appliance face. If sheathing the chase or finishing with other thickness materials, calculations will need to be made.

TYPICAL INSTALLATION SEQUENCE

The typical sequence of installation follows, however, each installation is unique resulting in variations to those described.

1. Construct the appliance framing.
2. Route gas supply line to appliance location.
3. Install nailing flanges and position the appliance.
4. Install the vent system and exterior termination.
5. Field wire and install operating control switch.
6. Make connection to gas supply.
7. Install (optional) outside Air Kit.
8. Check log position.
9. Checkout appliance operation.
10. Adjust burner to ensure proper flame appearance.

PRE-INSTALLATION NOTES

The fireplace may be installed directly on a combustible floor or raised on a platform of an appropriate height. Do not place fireplace on carpeting, vinyl or other soft floor coverings. It may, however, be placed on flat wood, plywood, particle board or other hard surfaces. Be sure fireplace rests on a solid continuous floor or platform with appropriate framing for support and so that no cold air can enter the room from under the fireplace.

The fireplace may be positioned and then the framing built around it, or the framing may be constructed and the fireplace positioned into the opening.

Usually, no special floor support is needed for the fireplace, however, to be certain:

1. Estimate the total weight of the fireplace system and surround materials such as brick, stone, etc., to be installed.
2. Measure the square footage of the floor space to be occupied by the system, surrounds and hearth extensions.
3. Note the floor construction, i.e. 2 x 6's, 2 x 8's or 2 x 10's, single or double joists, type and thickness of floor boards.
4. Use this information and consult your local building code to determine if you need additional support.

If you plan to raise the fireplace and hearth extension, build the platform assembly then position fireplace and hearth extension on top. Secure the platform to the floor to prevent possible shifting.

INSTALLING THE FIREPLACE

Step 1. Frame appliance enclosure as illustrated in **Figures 4 through 7 on page 5.**

Note: The framed depth, 13 1/2" (343 mm) from a framed wall, must always be measured from a finished surface. If a wall covering such as drywall is to be attached to the rear wall, then the 13 1/2" (343 mm) must be measured from the drywall surface. It is important that this dimension be exact.

If the appliance is to be elevated above floor level, a solid continuous platform must be constructed.

The header may rest on the top metal spacers, but must not be notched to fit around them.

Consult all local codes.

Step 2. Route gas line (**Figure 8**) using techniques and materials prescribed by local and/or national codes. It is recommended that a gas line of ½" or greater diameter be used to allow full gas volume to the fireplace. Undue pressure loss will occur if the pipe is too small. The appliance, as set up at the factory, is best suited for use with a gas line routed from the right side. The gas line may however be alternately routed from the left side.

When rigid pipe is used, an ANSI approved manual shut-off valve and union must be installed upstream of the fireplace.

Ensure that a sediment trap is installed in the existing gas line, if not, install a sediment trap upstream to prevent moisture and contaminants from passing through trap to the appliance controls and burners. Failure to do so could prevent the appliance from operating reliably.

An external regulator must be used on all propane (L.P.G.) heaters to reduce the supply tank pressure to 13" w.c. (maximum). Any copper tubing used to supply propane (L.P.G.) from the tank must be internally tinned.

IMPORTANT: HOLD GAS VALVE SECURELY TO PREVENT MOVEMENT WHEN CONNECTING TO INLET GAS LINE

WARNING: CONNECTING DIRECTLY TO AN UNREGULATED PROPANE (L.P.G.) TANK MAY CAUSE AN EXPLOSION.

All appliances are equipped with a gas flex line and shutoff valve attached directly to the gas control valve. To quickly and easily complete the gas line routing, use the gas flex line kit.

Step 3. Slide the fireplace into prepared framing or position fireplace in its final position and frame later.

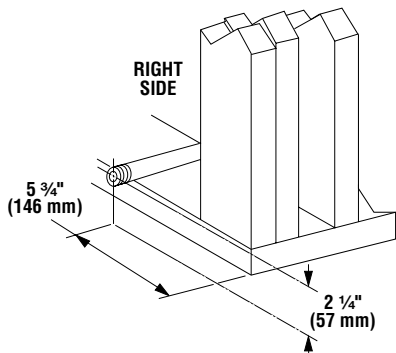

Figure 8

Refer to fireplace drawings and specifications on **pages 4 and 5** for framing dimensions and details. Framing header may be positioned directly on the fireplace top spacers.

IMPORTANT: UNDER NO CIRCUMSTANCES CAN THE FIREPLACE TOP SPACERS (FIGURE 2) BE REMOVED OR MODIFIED, NOR MAY YOU NOTCH THE HEADER TO FIT AROUND OR BE INSTALLED LOWER THAN THE SPACERS. THE HEADER MAY BE IN DIRECT CONTACT WITH THE TOP SPACERS BUT MAY NOT BE SUPPORTED BY THEM.

Fireplace should be secured to side framing members using provided nailing flanges. Use 8d nails (**see Figure 9**).

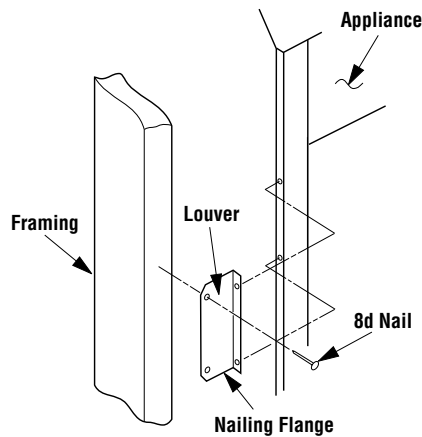

Figure 9

Note: The nailing tabs and the area directly behind the nailing tabs are exempt from the clearances described on the fireplace clearance label.

Step 4. Install the Vent System and Exterior Termination -

A - Connect a 4" (102 mm) Type B vent system to the appliance flue collar with two (2) No. 8 sheet metal screws (**Figure 10**) and install the remainder of the Type B vent to the outside.

B - The following venting configurations may be installed (**see Figure 11**):

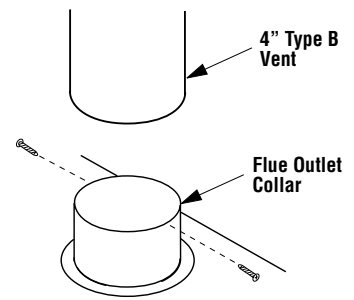

Figure 10

1 - Vertical - Minimum overall height of the vent system and appliance without an offset must be 12' (3.66 m)

2 - With Offset - Minimum overall height of the vent system and appliance must be 15' (4.57 m) when an offset up to 60 degrees from the vertical is used. There must be a minimum vertical vent height of 2 ft. (0.6 m) above the appliance collar before the offset can be applied.

3 - With Offset, when using the optional, 36GEP or 36GEP-BB, non-operable glass doors - Minimum overall height of the vent system and appliance must be 12' (3.66 m) when an offset up to 60 degrees from the vertical is used. The lower part of the offset may start at the appliance flue collar.

Maximum overall height of the vent system and appliance should not exceed 40 feet (12.19 m).

Install the B-vent system in accordance with the vent manufacturer's instructions.

CAUTION: THIS APPLIANCE CANNOT BE VENTED HORIZONTALLY.

Note: Refer to the vent manufacturers installation instructions for variations of venting techniques. If common venting of several units is contemplated, it should be discussed with an architect and the local Building Department.

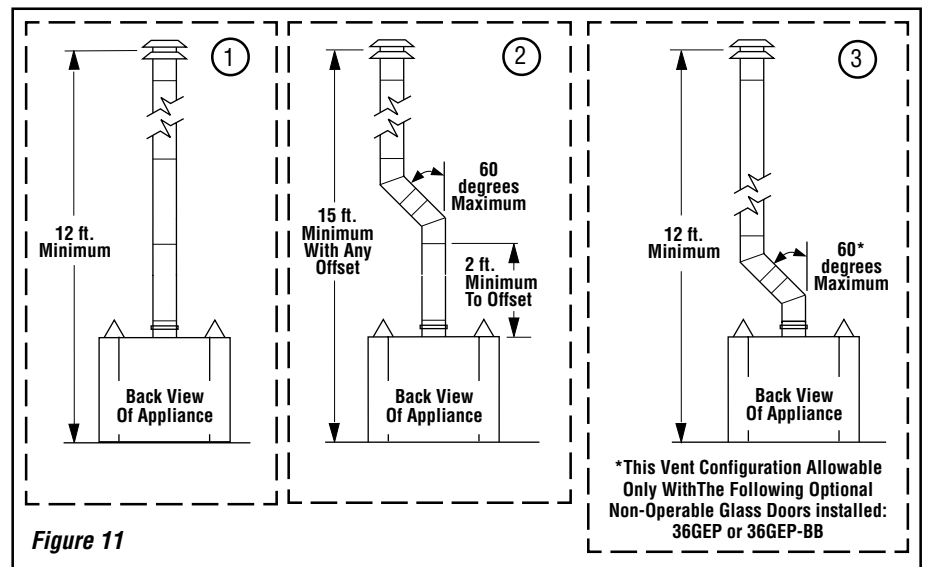

Figure 11

NOTE: DIAGRAMS & ILLUSTRATIONS NOT TO SCALE.

Step 5. Field Wiring – Refer to Section A for millivolt appliances and Section B for electronic appliances.

A. Millivolt Wiring – Units may be fitted at the factory with either a Honeywell millivolt gas control valve or an SIT millivolt gas control valve. Both valves have been tested with and approved for use with these appliances and are listed accordingly. Refer to **Figure 12** for wiring of Honeywell systems and **Figure 13** for wiring of SIT systems.

The gas valve has been set in place and has been pre-wired at the factory. No additional wiring is required unless the optional wall switch or optional remote control kit is to be installed. Locate the optional wall switch or optional remote control in the desired location and connect the millivolt wire (**see Figures 12 and 13**).

CAUTION: DO NOT CONNECT THE WALL SWITCH TO A 120V POWER SUPPLY.

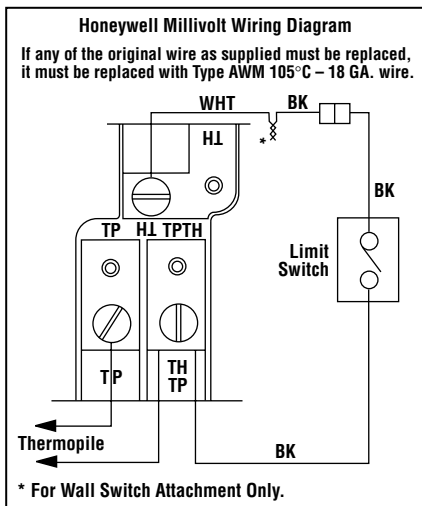

Figure 12

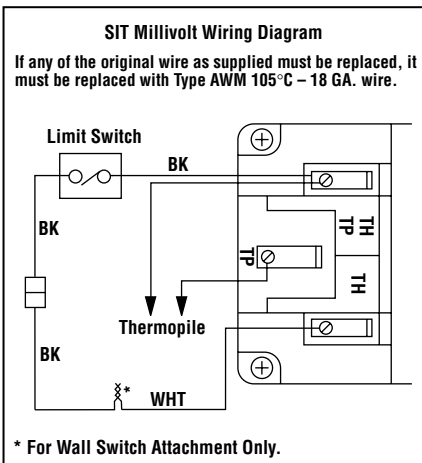

Figure 13

Note: *Optional wall switch not supplied. If the optional wall switch is not installed, the ends of the 15' (4.5m) coiled wire must be connected with a wire nut (not supplied) for the appliance to operate.*

B. Electronic Wiring – The electronic appliance must be connected to the main power supply. To install:

1. Route a 3-wire 120V 60Hz power supply to the appliance junction box and ground. (**See Figures 14 and 16**).
2. Locate and install a low voltage (24V) wall switch (not supplied) in the desired location. Connect the low voltage wire to this switch (**see Figure 14**).
3. After wiring is complete, replace the appliance junction box cover and secure with the hex head screws previously removed.

IMPORTANT: Ground lead must be connected to the green screw located on the outlet box. See Figure 14. Failure to do so will result in a potential safety hazard. The appliance must be electrically grounded in accordance with local codes or, in the absence of local codes, the National Electrical Code, ANSI/NFPA 70- (latest edition). (In Canada, the current CSA C22-1 Canadian Electrical Code.)

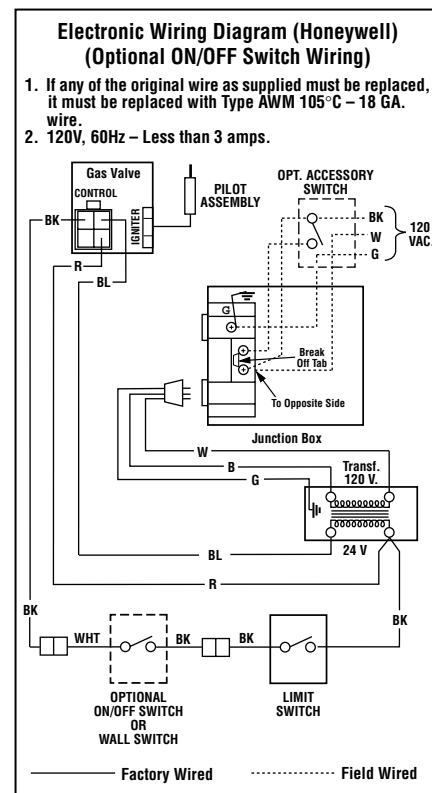

Figure 14

Step 6. Connecting Gas Line – Make gas line connections. All codes require a shut-off valve mounted in the supply line. **Figure 17** illustrates two methods for connecting the gas supply. The flex-line method is acceptable in the U.S., however, Canadian requirements vary depending on locality. Installation must be in compliance with local codes.

The gas control valve is located in the lower control compartment. To access the valve remove the removable access panel and set aside (**Figure 15**).

Note: *To provide increased access to the lower control compartment, you may choose to remove the front log. To do so, undo the twists in the wires securing the log from below to each of the grate tines. After removal of the log cut the wires off closely to the log before reinstalling it. These are only required for shipping.*

The millivolt control valve has a 3/8" (10 mm) NPT thread inlet port. The electronic control valve has a 1/2" (13 mm) NPT thread inlet port and is fitted with a 1/2" x 3/8" (13 mm x 10 mm) NPT fitting. Both the millivolt and electronic models are fitted with a gas flex line and shutoff valve, 3/8" NPT. Plan the connections accordingly.

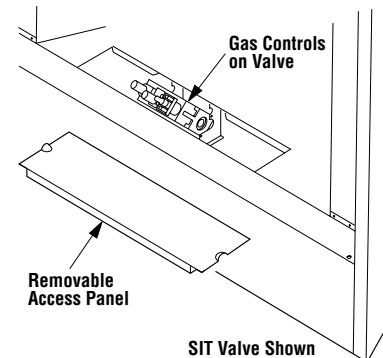

Figure 15

Secure all joints tightly using appropriate tools and sealing compounds (ensure propane resistant compounds are used in propane applications). Turn on gas supply and test for gas leaks using a soapy water solution. **Never use an open flame to check for leaks.**

- A. Mix a 50% dish soap, 50% water solution.
- B. Light the appliance (refer to the lighting instructions provided in the Homeowner's Care and Operation Instructions).

C. Brush all joints and connections with the soapy water solution to check for leaks. If bubbles are formed, or gas odor is detected, turn the gas control knob to the "OFF" position. Either tighten or refasten the leaking connection and retest as described above.

Note: Supply wires may be alternatively connected to the outlet using the screw terminals, however the black supply wire must be wired to a terminal that is opposite (across the outlet) the point where the white supply wire is connected.

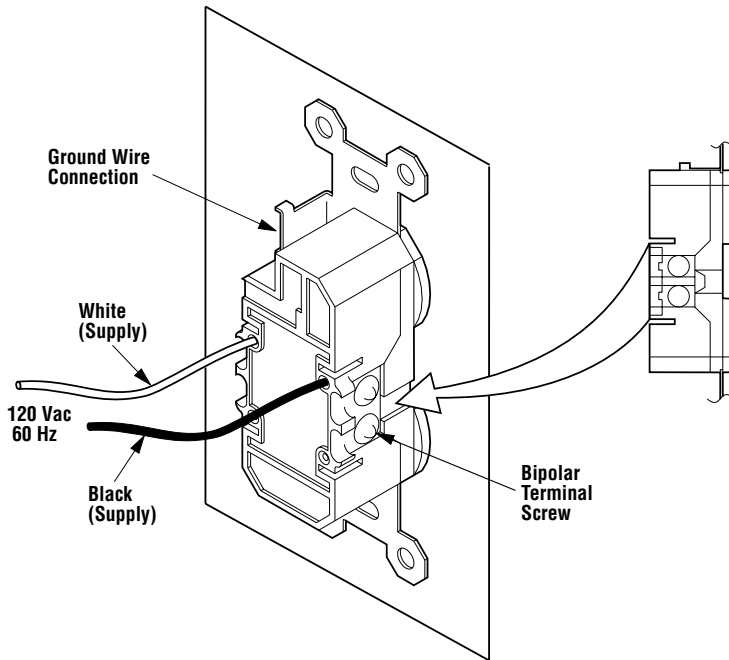

Figure 16

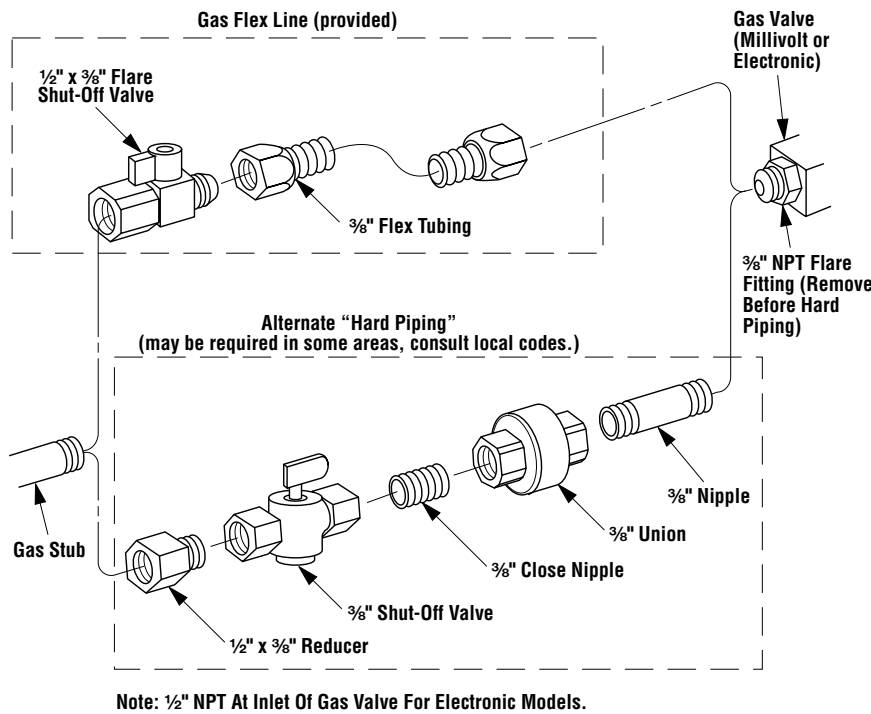

Figure 17

D. When the gas lines are tested and leak free, observe the individual tongues of flame on the burner. Make sure all ports are open and producing flame evenly across the burner. If any ports are blocked, or partially blocked, clean out the ports.

Step 7. Installing Outside Air Kit – These appliances are equipped with an outside (make-up) air door and integral actuator arm. If the appliance is to be installed with an outside air vent system, use only FireCraft Models FAOK-4 or FAOK-4LD Combustion Air Kits.

After completing the installation of the optional combustion air vent system the actuator arm must be put in service and tested to ensure proper operation before completing any enclosure around the firebox. Failure to do so may result in extensive and costly rework.

WARNING: DO NOT REMOVE THE ACTUATOR ARM LOCKING SCREW UNLESS THE COMPLETE OUTSIDE AIR VENT SYSTEM HAS BEEN INSTALLED IN ACCORDANCE WITH THE DETAILED INSTRUCTIONS PROVIDED WITH THE KIT.

Locate the actuator arm along the right side of the appliance firebox opening and refer to **Figure 18**. After completing the installation of the Outside Combustion Air Kit remove and discard the actuator arm locking screw.

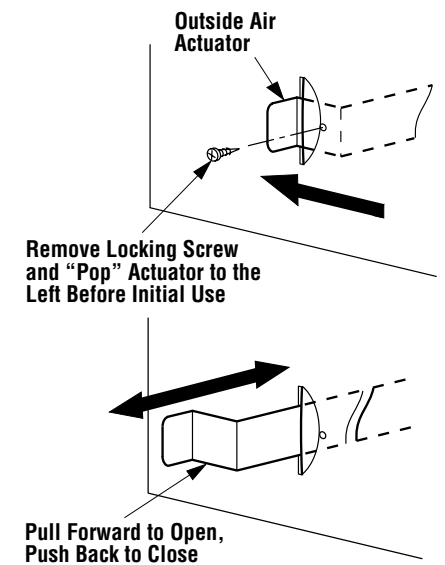

Figure 18

To operate, push the end of the actuator to the left as shown in **Figure 18**, until it "pops" free of its "locked" position. Pull the actuator forward to open the combustion air door, and push it back to close. To "lock" the combustion air door closed, ensure the actuator is pushed all the way back then push the end of the actuators to the right until the step in the actuator moves behind the appliance front face within the slotted opening.

Operate the actuator through several cycles including the "lock" position. Ensuring proper operation and freedom of movement. Return the actuator arm to the locked position.

Step 8. Log Placement – This appliance is equipped with two concrete logs wired and shipped in place (see **Figure 19**). As located at the factory the log set will require no adjustment before the appliance is placed in service. Ensure logs are unbroken and located as shown.

To provide increased access to the lower control compartment, you may chose to remove the front log. To do so, undo the twists in the wires securing the log from below to each of the grate tines. After removal of the log, cut the wires off closely to log before reinstalling it. These wires are only required for shipping. To place the front log, position it, centered, on the log rack in the cradel area provided.



Figure 19

APPLIANCE OPERATION

Step 9. Checking the System – With gas line installed run initial system checkout before closing up the front of the unit. Follow the pilot lighting instructions provided in the Homeowner's Care and Operation Instructions. For piezo ignitor location see **Figure 20** (milli-volt appliances only).

Note: Instructions are also found on the pull out labels attached to the gas control valve.

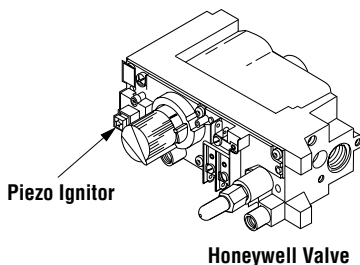
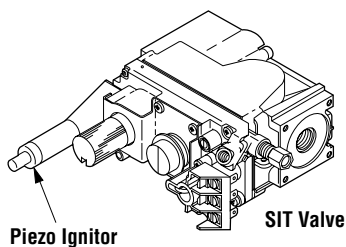

Figure 20

When first lighting the appliance, it will take a few minutes for the line to purge itself of air. Once purging is complete, the pilot and burner will light and operate as indicated in the instruction manual.

Subsequent lightings of the appliance will not require such purging. Inspect the pilot flame (remove logs, if necessary, handling carefully).

MANUALLY-RESET BLOCKED FLUE SAFETY SWITCH

This appliance is equipped with a manually-reset blocked flue safety switch. Refer to **Figure 21** for its location. If during appliance operation, the flame goes out (independently of the burner on/off wall switch), it may be due to the operation of this safety limit switch. First **allow the appliance to cool**. Then reset the safety switch by pushing the red reset button on the back of the switch.

To access the blocked flue safety switch, remove the limit switch bracket, with switch and low voltage wires attached. Push the red reset button and then reinstall limit switch bracket.

The appliance should then relight and remain lit. If this does not occur, **turn off the appliance and call a qualified service technician.**

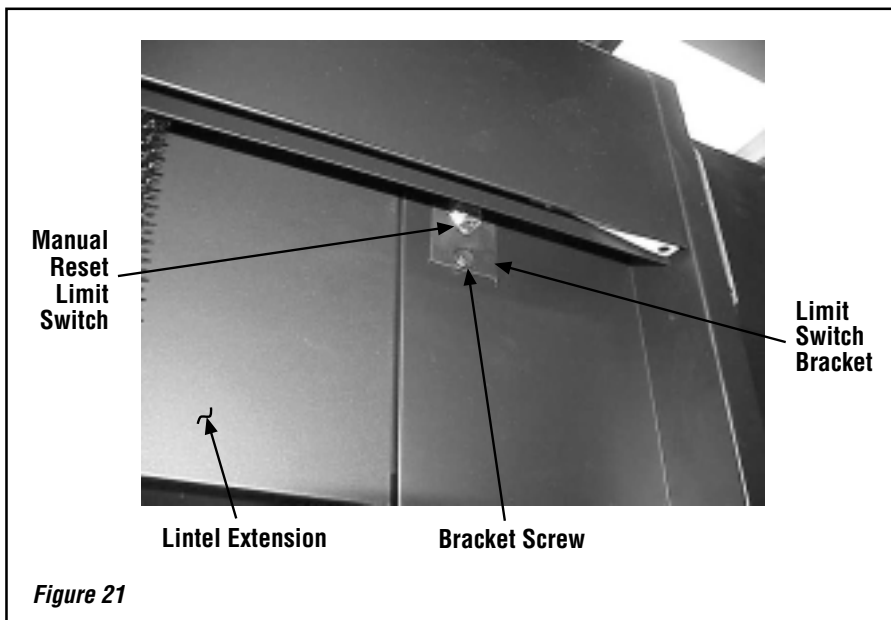

Figure 21

Millivolt Appliance Checkout

The pilot flame should be steady, not lifting or floating. Flame should be blue in color with traces of orange at the outer edge.

The top $\frac{3}{8}$ " (9 mm) at the pilot generator (thermopile) should be engulfed in the pilot flame. The flame should project 1" (25 mm) beyond the hood at all three ports (**Figure 22**).

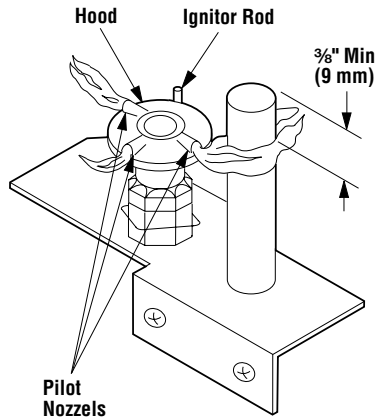

Figure 22

Replace the front log if removed for pilot inspection.

To light the burner; turn "ON" the remote wall switch and rotate the gas valve control knob counterclockwise to the "ON" position ("ON" will be to the left hand side of the valve).

Electronic Appliance Checkout

To light the burner, turn 'ON' the optional remote wall switch and turn the gas control switch to the "ON" position. Ensure the ignitor lights the pilot. The pilot flame should engulf the flame rod as shown in **Figure 23**.

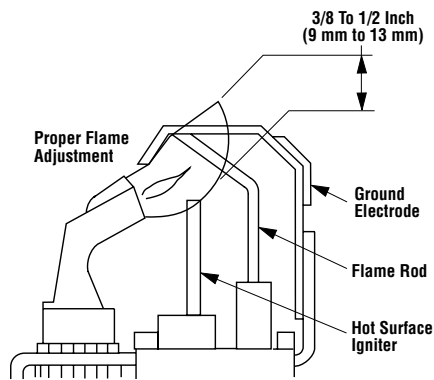

Figure 23

Step 10. Adjustments – The following paragraphs address adjustment concerns and procedures.

Flame Appearance and Sooting

Proper flame appearance is a matter of taste. Generally most people prefer the warm glow of a yellow to orange flame. Appliances operated with air shutter openings that are too large, or with long vertical vent runs, will exhibit flames that are blue and transparent. These weak, blue and transparent flames are termed anemic.

If the air shutter opening is too small sooting may develop. Sooting is indicated by black puffs developing at the tips of very long orange flames. Sooting results in black deposits forming on the logs, appliance inside surfaces and on exterior surfaces adjacent to the vent termination. Sooting is caused by incomplete combustion in the flames and a lack of combustion air entering the air shutter opening.

To achieve a warm yellow to orange flame with an orange body that does not soot, the shutter opening must be adjusted between these two extremes.

No smoke or soot should be present. If sooting conditions exist, the air shutter opening on the main burner can be adjusted. Normally, the more offsets in the vent system, the greater the need for the air shutter to be opened further.

WARNING: AIR SHUTTER ADJUSTMENT SHOULD ONLY BE PERFORMED BY A QUALIFIED PROFESSIONAL SERVICE TECHNICIAN.

Adjustment

To adjust the flame, position the air shutter to the nominal setting (**Figure 24**). Allow the burner to operate for at least 30 minutes. Observe the flame continuously. If it appears weak or sooty as previously described, adjust the air shutter open or closed until desired effect is achieved.

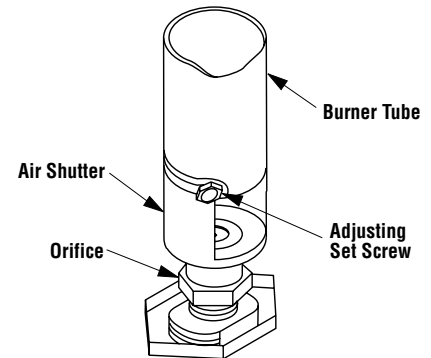

Nominal Air Shutter Settings
 Natural Gas - $\frac{1}{16}$ " (1.59 mm) Open
 Propane Gas - $\frac{1}{4}$ " (6.35 mm) Open

Figure 24

When satisfied that the appliance operates properly, proceed to finish the installation. Leave the control knob/lever in "ON" position and turn the remote switch "OFF." Replace the refractory access panel.

FINISHING REQUIREMENTS Wall Details and Combustible Mantels

Complete finished interior wall. To install the appliance facing flush with the finished wall, position framework to accommodate the thickness of the finished wall (*Figure 25*). This figure also indicates vertical installation clearances to combustible mantels. *Figure 26* also shows an example of a combustible mantel shelf projecting a maximum of 12" (305 mm) from the wall, and which must be installed a minimum distance of 15 ¾" (400 mm) from the top of the firebox opening.

A hearth extension is not required with this appliance. Any hearth extension used is for appearance only and does not have to conform to standard hearth extension installation requirements.

Note: Combustible wall finish materials and/or surround materials must not be allowed to encroach the area defined by the appliance front face (black sheet metal). Never allow combustible materials to be positioned in front of or overlapping the appliance front face.

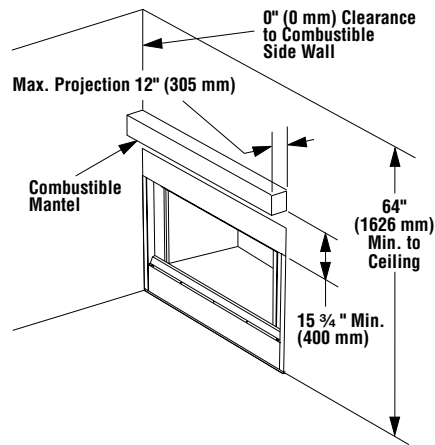

Figure 26

COLD CLIMATE INSULATION

If you live in a cold climate, seal all cracks around your appliance with noncombustible material and wherever cold air could enter the room. It is especially important to insulate outside chase cavity between studs and under floor on which appliance rests, if floor is above ground level.

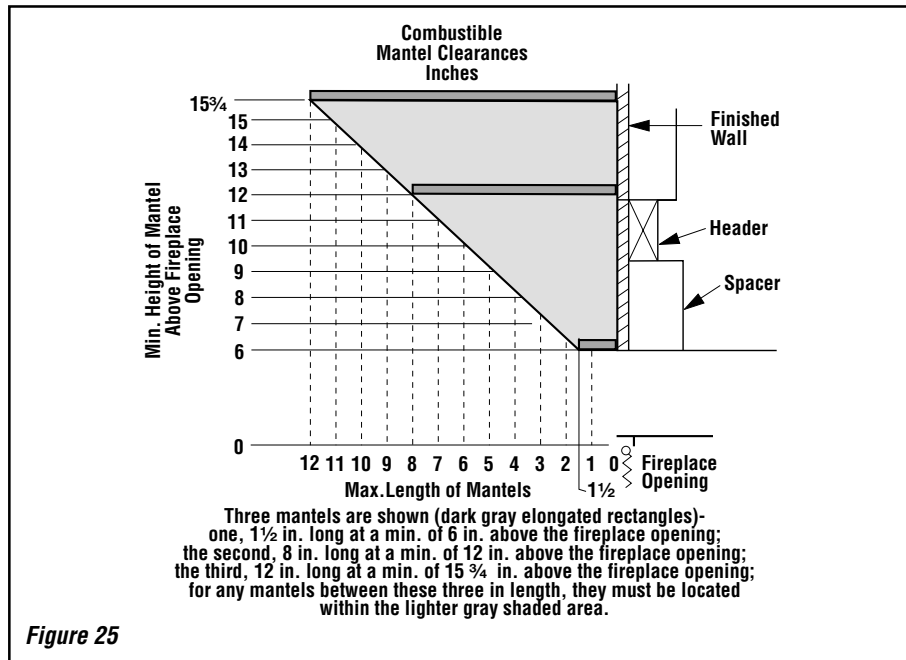

Figure 25

INSTALLATION ACCESSORIES

The following accessory items are available for use in the installation of this appliance.

Outside Air Kits Models F0AK-4 and F0AK-4LD

Outside Air kits are available with duct (FOAK-4) and without duct (FOAK-4LD) for use if outside combustion air is required or desired. If model FOAK-4LD is used it must be used in conjunction with locally purchased, non-combustible Class 1 or Class 0 flexible duct.

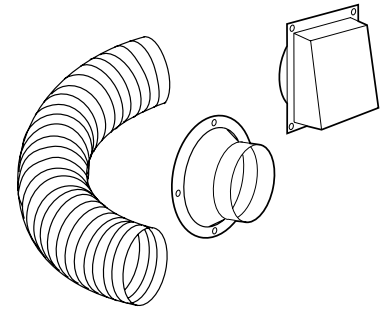

Outside Combustion Air Kits	81L87	F0AK-4
(with duct)	81L87	F0AK-4
(without duct)	81L88	F0AK-4LD

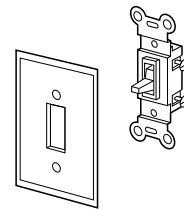

Wall Switch Kit	85L87	FWSK
-----------------	-------	------

Gas Conversion Kits

WARNING: THIS CONVERSION KIT SHALL BE INSTALLED BY A QUALIFIED SERVICE AGENCY IN ACCORDANCE WITH THE MANUFACTURER'S INSTRUCTIONS AND ALL APPLICABLE CODES AND REQUIREMENTS OF THE AUTHORIZED AGENCY HAVING JURISDICTION. IF THE INFORMATION IN THESE INSTRUCTIONS IS NOT FOLLOWED EXACTLY, A FIRE, EXPLOSION OR PRODUCTION OF CARBON MONOXIDE MAY RESULT CAUSING PROPERTY DAMAGE, PERSONAL INJURY OR LOSS OF LIFE. THE INSTALLATION IS NOT PROPER AND COMPLETE UNTIL THE OPERATION OF THE CONVERTED APPLIANCE IS CHECKED AS SPECIFIED IN THE OWNER INSTRUCTIONS SUPPLIED WITH THE KIT.

AVERTISSEMENT: CET ÉQUIPEMENT DE CONVERSION SERA INSTALLÉ PAR UNE AGENCE QUALIFIÉE DE SERVICE CONFORMÉMENT AUX INSTRUCTIONS DU FABRICANT ET TOUTES EXIGENCES ET CODES APPLICABLES DE L'AUTORISÉ AVOIR LA JURISDICTION. SI L'INFORMATION DANS CETTE INSTRUCTION N'EST PAS SUIVIE EXACTEMENT, UN FEU, EXPLOSION OU PRODUCTION DE PROTOXYDE DE CARBONE PEUT RÉSULTER LE DOMMAGES CAUSER DE PROPRIÉTÉ, PERTE OU BLESSURE PERSONNELLE DE VIE. L'AGENCE QUALIFIÉE DE SERVICE EST ESPONSABLE DE L'INSTALLATION PROPRE DE CET ÉQUIPEMENT. L'INSTALLATION N'EST PAS PROPRE ET COMPLÈTE JUSQU'À L'OPÉRATION DE L'APPAREIL CONVERTI EST CHÉQUE SUIVANT LES CRITÈRES ÉTABLIS DANS LES INSTRUCTIONS DE PROPRIÉTAIRE PROVISIONNÉES AVEC L'ÉQUIPEMENT.

In Canada

THE CONVERSION SHALL BE CARRIED OUT IN ACCORDANCE WITH THE REQUIREMENTS OF THE PROVINCIAL AUTHORITIES HAVING JURISDICTION AND IN ACCORDANCE WITH THE REQUIREMENTS OF THE CAN1-B149.1 AND .2 INSTALLATION CODE.

LA CONVERSION DEVRA ÊTRE EFFECTUÉE CONFORMÉMENT AUX RECOMMANDATIONS DES AUTORITÉS PROVINCIALES AYANT JURISDICTION ET CONFORMÉMENT AUX EXIGENCES DU CODE D'INSTALLATION CAN1-B149.1 ET .2.

Gas conversion kits are available to adapt your appliance from the use of one type of gas to the use of another. These kits contain all the necessary components needed to complete the task including labeling that must be affixed to ensure safe operation.

Kit part numbers are listed below and the following steps detail the conversion procedure.

Millivolt Conversion Kits

Honeywell

75L28 — Natural to Propane

75L27 — Propane to Natural

SIT

H2021 — Natural to Propane

H2022 — Propane to Natural

Electronic Conversion Kits

75L29 — Natural to Propane

75L26 — Propane to Natural

Step 1. Turn off the gas supply to the appliance. Remove the front glass door/frame (if used) from the appliance.

Step 2. Carefully remove the front log. Exercise care as not to break the log.

Step 3. Remove the access panel. Locate the screws securing the burner (tray) to the appliance. Remove the burner and retain the securing screws.

Millivolt Appliances

Step 4. SIT Systems - See *Figure 27* and the instructions provided with the kit. Using a Torx T20, remove and discard the three pressure regulator mounting screws. Remove the pressure regulator, spring, poppet, diaphragm and bushing. **Discard all removed components.**

Ensure the rubber gasket installed on the back of the replacement pressure regulator is properly positioned and install the new pressure regulator using the new screws supplied with the kit. Tighten screws to 25 In. lb. torque.

Step 5. Honeywell Systems - See *Figure 28* and the instructions provided with the kit. Remove the black thread-protecting cap. Remove the conversion flip cap by turning it counterclockwise.

Invert the flip cap so that the letters associated with the desired gas type are positioned closest to the valve body. NG is for natural gas and LP is for propane. Tighten the flip cap by turning it clockwise. Replace the black thread-protecting cap.

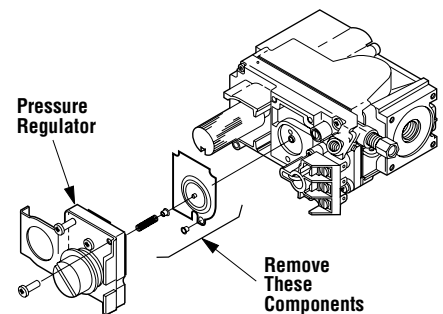

Figure 27

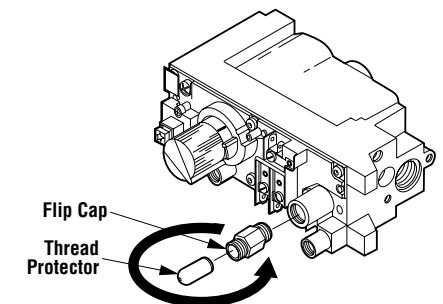

Figure 28

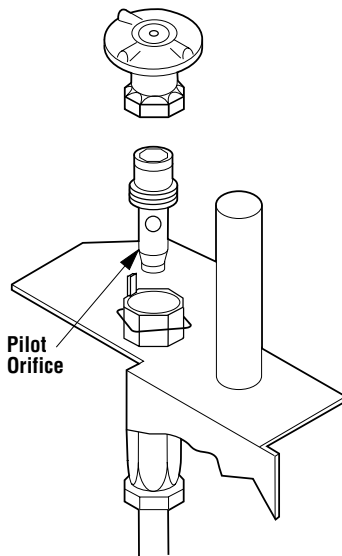

Figure 29

Step 6. All Millivolt Systems – Attach manometer to the manifold side pressure test fitting and verify manifold pressure reads 3.5 inches water column (0.87 kPa) for natural gas, and 10.0 inches water column (2.49 kPa) for propane gas.

Step 7. Refer to **Figure 29** and remove the pilot hood assembly to access the hexed pilot orifice. Remove and replace the orifice with the one provided with the kit.

Electronic Appliances

Step 8. Honeywell Electronic Valves - See **Figure 31** and the instructions provided with the kit. Remove the slotted cap screw, o-ring, pressure-regulating adjusting screw and spring. Retain all parts for possible later use. Install new components from the kit. Black cap and red spring for propane gas units. Silver cap and stainless steel spring for natural gas units. Before installing the cap, attach manometer to the manifold side pressure test fitting and adjust screw until pressure reads 3.5 inches water column (0.87 kPa) for natural gas, and 10.0 inches water column (2.49 kPa) for propane gas.

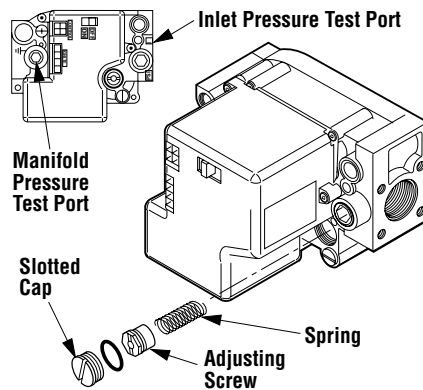
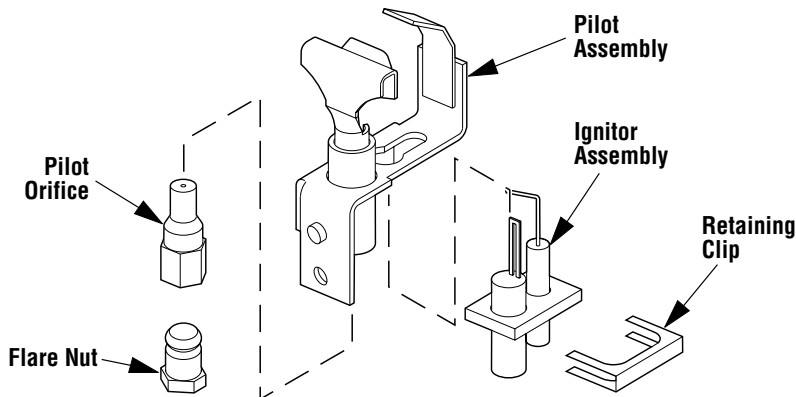

Figure 31



Note: If the ignitor assembly is damaged, a replacement kit is available, order Catalog Number 87L54.

Figure 30

See **Figure 30** and replace the pilot orifice as follows: Remove the ignitor assembly retainer clip, and carefully remove the ignitor assembly. **Exercise extreme care to prevent damage to or breakage of the ignitor assembly.** Remove the screw securing the pilot assembly to its mounting bracket. Back off the flare nut at the end of the pilot gas line to free the pilot assembly from the gas line. Remove the pilot orifice and replace it with the one provided with the conversion kit. Reinstall the pilot assembly by reversing the steps detailed here.

When reinstalling the ignitor assembly, use extreme care to prevent damage and breakage. Do not apply any leverage to the ignitor assembly while restoring the retainer clip to its original position.

All Models

Step 9. Unscrew the orifice from the manifold and replace it with the one provided with the kit, #49 (0.073) for natural gas units and (0.045) for propane (**Figure 32**).

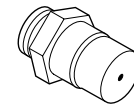

Figure 32

Step 10. Reassemble all removed components by reversing the procedures outlined in the preceding steps. Use pipe joint compound or Teflon tape on all pipe fittings before installing (ensure propane resistant compounds are used in propane applications, do not use pipe joint compounds on flare fittings).

Step 11. Attach appropriate conversion kit label (**Figure 33**) to the rating plate on the appliance.

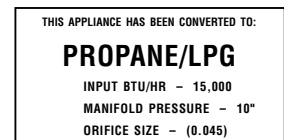
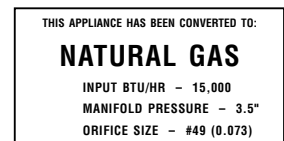

Figure 33

Step 12. Turn on gas supply and test for gas leaks.

The manufacturer reserves the right to make changes at any time, without notice, in design, materials, specifications, prices and also to discontinue colors, styles and products.
Consult your local distributor for fireplace code information.

Printed in U.S.A. © 2002 by Lennox Hearth Products
P/N 700,003M REV. H 05/2004

LHP
1110 West Taft Avenue • Orange, CA 92865