

# Sioux Narrows – Nestor Falls

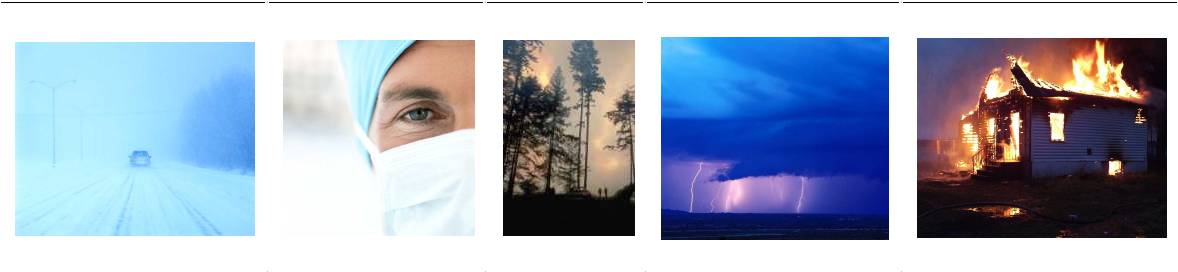

# Emergency Preparedness Workbook



# How to Use this Workbook

1. Take the Emergency Preparedness Challenge! Find out how prepared you are!
2. Get prepared using the 26 Weeks to Emergency Preparedness as a guide.
3. Refer to the Sections in the Workbook to find out how to prepare and respond appropriately in an emergency/disaster.
4. Keep this workbook near your main phone for easy access in an emergency.

## Section 1 – Emergency Preparedness for You and Your Family (page 1)

- Provides emergency preparedness suggestions to help you and your family become self-sufficient before an emergency/disaster.

## Section 2 – Emergency Preparedness for Your Home (page 15)

- Provides suggestions for preparing your home for a variety of emergencies and how you can reduce risks and make your home a safer haven before an emergency/disaster.

## Section 3 – Responding Safely During Emergencies (page 35)

- Provides suggestions to help you and your family know how to respond appropriately during emergencies/disasters and increase your ability to survive well.

## Section 4 – Recovery (Moving Forward) (page 56)

- Provides suggestions for recovering from emergencies/disasters and getting back on track after an emergency/disaster occurs.

## Section 5 – Personal Document Tools (Fill Out & Photocopy – page 66)

- Provides fill in the blank forms that you can use to write down Important Individual and Family Information and develop your Emergency Escape Plan before an emergency/disaster.

## Section 6 – Information Resources (page 72)

- Provides additional information resources that you may wish to pursue (anytime)

## Acknowledgements

A HUGE THANK YOU to Cowichan Valley, BC, who provided us with their Emergency Preparedness Workbook to use as the basis for this document. Special thanks to Woody Linton, CEMC/Chief of Fire Rescue Services, and Wanda Kabel, Chief Administrative Officer, who worked together to complete this project for Sioux Narrows – Nestor Falls.

## Disclaimer

Every reasonable effort has been made to ensure the accuracy of this Workbook. The local authorities assume no responsibility and disclaim any liability for any injury or damage resulting from the use or effect of the information specified in the manual.

# TABLE OF CONTENTS

## Local Community Information & Preparedness Challenge

How to Use this Workbook

Take the Emergency Preparedness Challenge! i

26 Weeks to Emergency Preparedness ii

Personal Notes iv

## Emergency Preparedness for You and Your Family 1

Emergency Comfort Kits (Grab 'n Go, Car Kits) 2

Contact Numbers to Use In Case of Emergency (ICE) 2

Developing a Reunion Plan 3

Develop a Family Emergency Plan 4

Considerations for Special Needs 5

Emergency Water Supplies 6

Emergency Food Supplies 8

First Aid Supplies 10

Home Emergency Supplies 11

Your Pets Are Counting on You 13

Emergency Planning for Farm Animals 14

## Emergency Preparedness for Your Home 15

Home Hazard Hunt (Risk Assessment) 16

Making Your Home Structurally Safe 18

Securing the Water Heater 21

Securing Furniture and Its Contents 22

Shutting Off Fuel Oil and Propane Gas 24

Shutting Off Electricity 25

Shutting Off Water 26

Protecting Your Home from Fire 27

Fire Safety 29

Protecting Your Home from Forest Fire 31

Protecting Your Home from Flooding 32

Hazardous Materials Safety 34

<b>Responding Safely During Emergencies</b>	<b>35</b>
Evacuations and Sheltering In Place	38
Fires	42
Forest Fires	45
Floods	46
Hazardous Materials	49
Pandemics (Disease Outbreaks)	51
Power Outages	54
Water Supply Interruptions	58
Winter Storms	59

<b>Recovery (Moving Forward)</b>	<b>56</b>
Getting Back on Track	57
Health and Safety Guidelines	58
Emotional Responses to Emergencies	61
Helping Children Cope with Their Fears	62
Helping Pets Cope with Their Fears	63
Recovery Resources	64

<b>Personal Document Tools (To Fill Out &amp; Photocopy)</b>	<b>66</b>
Emergency Contact Person Cards	67
Important Individual and Family Information	68
Our Escape Route Plan	69
Pets and Farm Animals - Important Telephone Numbers	70
Emergency Services Reception Centres	71

<b>Information Resources</b>	<b>72</b>
Useful Information & Resource Links	73
Local Community Emergency Services	74
Glossary of Emergency Preparedness Terms	77
Personal Notes	78
Emergency Contact / Family Reunion Cards (To Fill Out)	79
Personal Notes	81

## Take the Emergency Preparedness Challenge!

### Are You Prepared for Winter Storms, Blackouts, Flooding and Forest Fires?

Yes/No

1. Do your family members know how to keep themselves safe in a disaster?
2. Do you have a Grab 'n Go kit for each member of your family? (see page 2)
3. Does your family have a REUNION PLAN in case you are separated during a disaster? (see page 3)
4. Do you know what plans your children's or grandchildren's schools have developed for protection during disasters?
5. Do you have at least 7 days of drinking water (7 gallons or 31.5 litres per person) safely stored for your family? (see page 6)
6. Have you collected and stored emergency supplies to provide for your family for an extended period of time? (see page 8)
7. Have you conducted a Home Hazard Hunt? (see page 16)
8. Do you have the means to prepare meals if the power is out for an extended period of time? (see page 11)
9. Does each member of your family know how to turn off home utilities such as water, gas and electricity? (see page 24)
10. In a sudden power outage, could you quickly locate a flashlight or have you purchased home power failure lights?
11. Do you have a basic First Aid Kit? (see page 10)
12. Do you know where your local Emergency Reception Centre is located? (see page 71)
13. Have you determined how you will signal for assistance, if a disaster strikes?
14. Is your workplace prepared in the event of a major disaster?

#### How Did You Do?

- 14 out of 14 yes answers - Congratulations!
- 10 - 13 yes answers - A little more work to do here
- 7 - 9 yes answers - You are halfway there
- 4 - 6 yes answers - This weekend would be a good time to continue repairing
- 0 - 3 yes answers - Please get started now

If you answered "no" to any of these questions, now is the time to act.

**DISASTERS HAPPEN!!** Don't wait until it is too late!

For more information, please contact us at 807-226-5241

## 26 Weeks to Emergency Preparedness

1. Identify safe places in your home and on your property. Practice evacuation drills using different escape routes. Your community may set up a reception centre for evacuees during an emergency. (see pages 36, 40 & 71)
2. Identify a family reunion place away from home but close to your regular meeting places between work and home or school. (see page 3)
3. Arrange an Emergency Contact person, along with other emergency phone numbers near each telephone and in each person's wallet or backpack. (see pages 3 & 79)
4. Stock your home with at least a seven-day supply of water for every family member and don't forget to include water for pets. It is best to store at least four litres (1 gallon) of water per person. (see page 6 & 7)
5. Get a large portable container with a tight-fitting lid to use as an emergency evacuation kit. A plastic storage bin, suitcase or garbage can works well, particularly one with wheels. Choose an accessible location for the container near an exit or in a garage or storage shed and label the container. (see page 11 & 12)
6. Stock your home with several varieties of packaged foods, canned meats and dried fruit. Include a manual can opener. If needed, include infant supplies including disposable diapers, disposable bottles, formula, etc. Plan for at least a seven-day supply of food for each family member. (see pages 8 & 9)
7. Add more food items and supplies for pets to your supplies. (see pages 13 & 14)
8. Get a portable radio and extra batteries for your emergency kit.
9. Learn about hazards. Know the hazards in your community. Check out the section on "Responding Safely During Emergencies". (see pages 35 - 59). Also do a home hazard hunt to make your home safer. Secure appliances and heavy furniture and move beds away from overhead objects like heavy mirrors and windows. (see pages 15 - 34)
10. Prepare a first-aid kit that includes prescription medications, eyeglasses, bandages, sterile gauze pads, tape, scissors, tweezers, antibiotic ointment, hydrogen peroxide and other items such as over-the-counter pain pills. (see page 10)
11. Give every family member specific safety tasks to do in an emergency. For example, designate one person to be in charge of turning off electricity, one to collect the emergency container, one to track down family members and make sure people with disabilities or special health needs are provided for. Make sure someone is also delegated to looking after any pets. (see pages 4 & 5)
12. Add a flashlight and extra batteries, along with candles and waterproof matches to your kit. (see page 11)

13. Add some dried soups and other items such as peanut butter to your emergency kit.
14. Check your insurance policies and make inventory records of your possessions.
15. Stock your kit with both large and medium-sized plastic garbage bags (orange or yellow bags make good visible signals). Large bags can also be used as ponchos, ground covers or blankets. Add plastic or paper dishes and cups as well.
16. Add a change of clothing for each family member to your kit. Be sure to include seasonal clothing (winter/summer), heavy work gloves and sturdy shoes.
17. Add additional canned or freeze-dried food like stews, tuna fish, baked beans and vegetables to your kit.
18. Enroll a family member in a first-aid course. Pack HELP/OK signs in your kit.
19. Assemble important documents like wills, insurance papers, medical records, credit card numbers, inventory of possessions, identification, etc. Make copies and store originals in a fireproof/waterproof container that will be accessible if your home is damaged. Keep recent photos of family and pets to assist searchers to reunite you.
20. Add personal items such as toilet paper, handi-wipes, soap, detergent, toothbrush, toothpaste, comb, sanitary supplies, etc. to your emergency kit.
21. Add evaporated, canned or powdered milk to your kit.
22. Get a large bucket with a tight-fitting lid to use as a toilet, and put it with your emergency kit. Use the bucket to store other emergency tools like an axe, a folding shovel, rope and powdered lime for deodorizing.
23. Add sleeping bags or blankets (emergency blankets take up less space) and consider adding plastic emergency ponchos to your kit.
24. Add more canned, freeze-dried, or dehydrated food products to your kit until you have at least a three-day supply for each family member.
25. Add a pocket knife, cutlery, a whistle and spare set of house and car keys as well as items such as books, toys and cards as well as a family photo album to your kit.
26. Meet with neighbours to discuss emergency preparations and the possibility of sharing items such as generators.

Now you and your family are personally prepared for most emergencies.

Remember to rotate supplies to keep them fresh.

You may wish to donate goods to the local food bank before they reach their expiration date!





# Emergency Preparedness for You and Your Family

## Top Recommendations:

1. Keep a sturdy pair of shoes in a bag under your bed for safe escape. Keep a flashlight tucked into one of them or ensure each bedroom has a power failure light.
2. Practice getting out of your home, school or work place safely.
3. Pack a small grab 'n go comfort kit for each family member to keep with them at all times (water, food bars, light stick, emergency blanket, whistle, etc. - see page 2).
4. Use ICE (In Case of Emergency) in your cell phone address book to designate who to notified if you are injured or carry emergency contact info at all times (see page 2).



## This section of the workbook will:

- Provide preparedness strategies that are common to all disasters. You plan only once, and are able to apply your plan to all types of hazards.
- Provide suggestions to help you and your family become self-sufficient in the event of an emergency/disaster.
- Offer a guideline for putting together a family emergency plan.
- Outline water, food, medical, and other emergency supplies you should have on hand.
- Teach you how to practice and maintain your family emergency plan.

## Emergency Information

Listen to local media such as: CBC Radio FM 95.7, CJRL MIX FM 89.5, CFOB FM 93.1, CKSX FM - 91.1 to get timely information updates during an emergency/disaster.

Plan for the worst and be ready for anything.

## Emergency Comfort Kits

A major emergency/disaster could cause you to spend an extended time away from home and you will want to have supplies to keep you as comfortable as possible.

### Suggested Personal Grab 'n Go Kit

(personalize for your needs & keep with you at all times)

Bottled water		Flashlight/radio
Nutritious foods (dried fruits, granola bars, nuts or beef jerky)		Whistle
Personal medications		Emergency blanket and garbage bags
Personal toiletries		Extra pair of eye glasses
Dust masks and gloves		Extra money, coins, phone cards
Family photos (recent)		Book and/or game
Personal papers (copies of insurance, emergency contacts, prescriptions & identification)		

### Suggested Car Kit (\*\*Keep up car maintenance and fuel so you don't run out)

Bottled water		First aid kit & manual
Nutritious foods (dried fruits, granola bars, nuts or beef jerky)		Fire extinguisher
Comfortable, sturdy walking shoes		Flashlight (extra batteries)
Warm blanket		Flares, candles w/matches & jar
Heavy-duty work gloves (leather)		Ziploc bags, toilet tissue
Dust masks and gloves		Hardhat
Change of clothing		Large, sturdy backpack
Road map & compass		Deck of cards, good book
Shovel and sand, kitty litter or other traction aids		Ice scraper and brush
Duct tape and garbage bags		Booster Cables

## Contact Numbers to Use In Case of Emergency (ICE)

Your cell phone can be a useful tool in times of crisis. At the touch of a button it can call 9-1-1 or the police, as well as to reunite loved ones separated during a disaster.

At the scene of an accident, first responders or rescue services arrive and want to treat you quickly and also notify your family or friends.

You can make their job easier by adding entries in your cell phone address book under the label ICE with the names and phone numbers of people that should be called in case of an accident or injury. Simply put the acronym ICE before the names you want to designate as key contacts or next of kin creating entries such as ICE1, ICE2 and ICE3 etc. It only takes a few seconds to help Responders know right away who to notify.



Congratulations!

Now you are ready to look after your basic needs wherever you happen to be!

## Develop a Reunion Plan

There is a good chance that you may not be with your loved ones when an emergency/disaster occurs. To find your family members as quickly as possible after a major disaster, you need to identify at least 3 reunion sites and an emergency contact person to help you find each other and get back together.

**\*Remember - local telephone and cell phone services may not be available**

### Reunion Sites

- Your family's first reunion site should be your home. Identify 2 other places to go if your home is not accessible. Possible sites may include: neighbours, friends, nearby relatives' homes, or designated reception centres. If you need to leave your reunion site, make sure you leave a note telling others where you have gone.



In Neighbourhood: \_\_\_\_\_

Outside Immediate Area: \_\_\_\_\_

- Fill in the reunion sites on the back of the emergency contact cards for each family member to carry with them at all times (see cut out cards on pages 79 & 80).

### Emergency Contact Person

- Choose a relative or friend who lives outside the disaster area, preferably in another province or country that family members can contact if it becomes impossible to reach your home or reunion sites. Communication within a disaster area is harder to establish than calling to an area not affected by the disaster.

EMERGENCY CONTACT PERSON: Name: _____ Address: _____ Home Phone: _____ Work Phone: _____ Cell Phone: _____ Pager: _____
---

- Fill in the emergency contact cards with this information for each family member to carry with them at all times (see cut out cards on pages 79 & 80).
- In the event family members cannot reach one of your reunion sites, remind them to contact this person as soon as they can after the emergency and report how and where they are and their plans for the next few days. Keep conversations short as the phone system will be overloaded with people trying to contact their loved ones.

Update Family Photos (including pets) often so searchers can help reunite families!

## Develop a Family Emergency Plan

Safety during emergencies requires advance planning and preparation. Taking time to identify a nearby neighbour and acquainting them with your needs can provide peace of mind now as well as vital help following a disaster.

### Before the Emergency

- Assess your own needs, capabilities, and limitations and write them down. Be sure to include your requirements for special equipment and medications.
- Sketch your home's floor plan. Mark the safest place for you to be, in each room, during an emergency. Include exits, hallways, and alternate escape routes. Note obstacles that might make a safe exit difficult and plan to remove them if possible.
- Create a network of neighbors, relatives, friends, and coworkers to assist you in an emergency. Discuss your needs and make sure everyone knows how to operate necessary equipment.

### Local Contact Information

Name: \_\_\_\_\_

Address: \_\_\_\_\_

Phone Number: \_\_\_\_\_

Name: \_\_\_\_\_

Address: \_\_\_\_\_

Phone Number: \_\_\_\_\_

Name: \_\_\_\_\_

Address: \_\_\_\_\_

Phone Number: \_\_\_\_\_

Name: \_\_\_\_\_

Address: \_\_\_\_\_

Phone Number: \_\_\_\_\_

## Considerations for Special Needs

If you or someone close to you has a disability or a special need, you may have to take additional steps to protect yourself and your family in an emergency.

Disability/Special Need		Additional Steps to Consider
Hearing impaired		May need to make special arrangements to receive warnings
Mobility impaired		May need to make special arrangements to get to a shelter
Working parents		May need to make alternate child care arrangements.
Non-English speaking persons		May need assistance planning for and responding to emergencies.
No vehicle		May need to make arrangements for transportation
Special dietary needs		Plan to have an adequate emergency food supply
Daily Medication needs		Ensure you have an adequate supply

### Planning for Special Needs:

- Find out about special assistance that may be available in your community.
- Discuss your needs with your employer.
- If you are mobility impaired & live or work in a multi-story building, have a stairway escape chair.
- If you live in an apartment building, ask the management to mark accessible exits clearly and to make arrangements to help you leave the building.

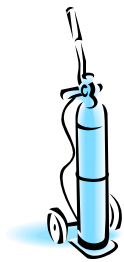

- Keep specialized items ready, including extra wheelchair batteries, oxygen, catheters, medication, food for service animals, and any other items you might need.
- Be sure to make provisions for medications that require refrigeration.



- Keep a list of the type and model numbers of the medical devices you require.

## Emergency Water Supplies

Water is essential for survival. It is vital that all household members learn how to shut off the water at the main house valve. Storing an alternative supply of water is also essential.

Preparing to Shut Water Off (see page 26)

- Locate the shut-off valve for the water line that enters your home.
- Make sure this valve can be completely shut off. Your valve may be rusted open, or it may only partially close. Replace it if necessary.
- Label this valve with a tag for easy identification, and make sure all household members know where it is located.



### Amount to Store

Store 2.5 litres to 5 litres per person per day. Seven days is the absolute minimum for which you should be prepared. This water will be required for drinking, food preparation, washing dishes, brushing teeth and other hygiene needs.

### Storing Emergency Water

- Store water in sturdy, opaque plastic food grade pails, jugs or bottles. Plastic soft drink containers work well for short-term storage but use opaque jugs available from camping supply stores or water distributors for long-term storage. (DO NOT USE milk containers which become brittle over time). It is recommended to store water containers on wood rather than directly on cement floors.
- Rinse the inside of the bottle thoroughly. Add a few drops of chlorine bleach or vinegar OR baking soda (NOT TOGETHER) to some rinse water and shake well. Empty the bottle and fill with fresh water to the very top.
- Date the bottle and label it "Purified Drinking Water".
- Store bottles in cool, dark locations (up off cement floors). Storing some in freezers can provide additional water and help keep food frozen longer should the power be off for an extended period of time.
- Water supplies should be replaced every six months.
- Avoid storing in areas where toxins are stored (i.e. gasoline & pesticides. These vapours can penetrate the plastic over time.

### Additional Sources of Water



- Hot water heaters.
- Existing water in plumbing (may need to be purified).

### Purifying Water for Immediate Needs

- Strain out any sediment or particles from the water by pouring it through several layers of paper towels, cheesecloth, or coffee filters.

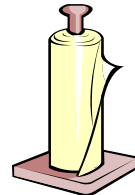

- Use ONE of the following purification methods.

a) Boil the water for 10 minutes.



b) Add liquid household bleach (must contain 5.25% sodium hypochlorite and be less than one year old) in these amounts:

WATER AMOUNT	WATER IS CLEAR	WATER IS CLOUDY
1 litre (quart)	2 drops	4 drops
5 litres (~1 gallon)	5 - 8 drops	16 drops
25 litres (~5 gallons)	½ teaspoon	1 teaspoon

c) Purification tablets may be used, but have a short shelf life so make sure you note the expiration date and replace them regularly.



**Caution:** Do not drink water from swimming pools or waterbeds. Their high concentration of salts and/or chlorine can cause serious health problems. Use for hygiene purposes only.

## Emergency Food Supplies

An emergency can disrupt your ability to purchase food. It is wise to maintain an extra two weeks supply of food on hand. Check your supplies regularly to make sure you have enough.

### Selecting Foods for Emergency Supply

- Foods that require little or no cooking or refrigeration.
- Foods that require little or no water for preparation.
- Foods that will not increase thirst (i.e. low in sodium).
- Foods that will meet the needs of family members requiring special diets.
- Choose portions that can be consumed by your family in one meal.
- Foods that are familiar to your family (comfort foods).



### Suggested Foods to Store

- Ready-to-eat canned meats, fish, beans, fruits and vegetables
- Packaged juices, milk and soup
- Peanut butter, jelly, crackers, granola bars and trail mix
- Comfort foods, such as hard candy, sweetened cereals, candy bars and cookies
- Dried foods
- Instant meals that don't need cooking or water

### Additional Items to Store

- Manual can opener
- Utility knife
- Bottle opener
- Camping stove & fuel
- Waterproof matches
- Pots & pans

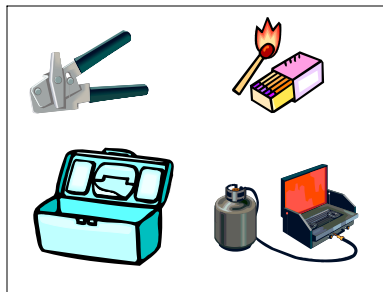

- Paper towels
- Aluminium foil
- Charcoal grill & charcoal
- Heavy duty plastic bags
- Small Tool Kit
- Utensils

### Storing Emergency Foods

- Keep food in covered containers, date, rotate into use 1 or 2 times a year and replace.
- Store foods in a cool, dry, dark place (i.e. a closet and package in opaque containers). High temperatures contribute to rapid deterioration of many food types.
- Protect food from rodents and insects by storing in metal containers or large sealable plastic garbage containers on wheels.



## Using Emergency Food



- Use perishable foods in your refrigerator first (if not contaminated by flooding).
- Use frozen foods in your freezer second.

Note: Thawed food usually can be eaten if it is still "refrigerator cold." It can be re-frozen if it still contains ice crystals. Remember, "When in doubt, throw it out."

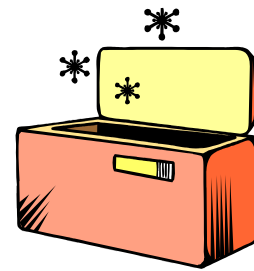

- Use canned foods and dry mixes last.
- Discard cans that bulge at the end or are leaking.
- Do not eat or drink anything from open containers near shattered glass.
- Keep cooking and eating utensils clean.



- Keep your hands clean by washing them frequently with soap and water that has been boiled or disinfected.
- Remember to wash hands for at least 20 seconds each time.

- Keep garbage in closed containers and dispose outside, burying garbage in plastic bags if necessary so it can be dug up and disposed of properly later.



## First Aid Supplies

Your first aid kit should contain those things necessary to meet the needs of your family. Use this kit for your everyday first aid needs and replace items you use to keep them fresh.

- Assemble or purchase a first aid kit. Storing these supplies in a case, a fishing tackle or toolbox, or even a small cardboard box with a handle, makes them easy to carry. Tape a list of the contents to the inside of the lid.
- Store prescription medications and copies of critical medical information in your Grab 'n Go kit or in watertight bags in the refrigerator.
- Check expiration dates periodically. Replace items that have expired.



### Suggestion of bandages to store

- Band-Aids
- Pressure bandages
- Butterfly bandages
- 3 to 6 triangular bandages
- Rolled gauze (1", 2", 3" widths)
- Cotton tipped swabs
- Adhesive tape (1/2 ", 1" wide rolls)
- Bandage, sterile rolls (2", 4" widths)

### Additional supplies

- First Aid manual
- Writing materials (pen, paper, etc)
- Scissors, tweezers & safety pins
- Needle & thread
- Thermometer
- Tissues
- Skin lotion, sunscreen, insect repellent
- Plastic bags
- Pre-moistened towelettes
- Sanitary napkins
- Hot water bottle
- Instant cold packs
- Mylar space blankets
- Splinting materials
- Glasses, contact lenses & supplies
- Waterproof matches

### Suggestion of medicines to store

- Pain relievers
- Antibiotic ointment
- Individually wrapped alcohol swabs
- List of prescription medications (taken on regular basis)
- Diarrhea & laxative medications
- Prescription medications (2 week supply)
- Eye drops

# Home Emergency Supplies

*It is important to plan in advance for alternative ways of caring for your needs if the normal community services have been disrupted. The information provided in these lists offers suggestions and safety tips to help you prepare for the unexpected.*

## Lighting

Store two or three alternative sources of light:

- Home Power Failure Lights are an inexpensive way to provide immediate emergency lighting during power failures.



- Flashlights - solar, windup, shake-up or battery operated.
- Light sticks - these can provide light for 1 to 12 hours (great if there is concern about gas leaks as these won't ignite the gas).
- Candles - in candle holders or glass jars taller than the candle in case the candle is knocked over.
- Camping lanterns - store extra fuel, wicks, mantles, and matches - use only outdoors.

### Caution:

**Make sure there are NO gas leaks before using any open flame (matches, candles, lanterns) or even flicking any electrical switches on or off.**

## Cooking

Make sure you have at least one alternative way to cook your food:

- Camp stoves, sterno stoves, barbecues, and hibachis - store extra propane, charcoal, lighter fluid, and matches outside.
- Fireplaces - inspect chimney and flue for cracks before using.
- Fondue pots and chafing dishes - store extra fuel.
- Pressure Cookers and old fashioned hay boxes can reduce fuel consumption.

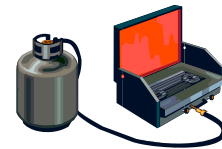

### Quick Tips:

- Heavy-duty aluminium foil - requires less clean up than a pan.
- Paper plates and cups, plastic utensils and paper towels.

**Caution:** Never burn charcoal or light barbecues indoors (may cause carbon monoxide poisoning).

## Shelter

Make sure you have other shelter options available to help you and your family be as comfortable as possible.



- Tent or waterproof tarp
- Sleeping bags
- Blankets
- Mylar blankets
- Newspapers (for insulation)
- Air mattresses or cots

## Sanitation

The lack of sanitation facilities following a major emergency can quickly create secondary basic guidelines are followed. If the water lines are damaged or if damage is not flush the toilet. Avoid digging holes in the ground as untreated raw sewage in ground water supplies, attract flies and spread disease.



- Store a large supply of heavy-duty plastic bags, twist ties, disinfectant (powdered chlorinated lime – but not quick lime), and toilet paper.
- A good disinfectant that is easy to use is a solution of 1 part liquid bleach to 10 parts water (dry bleach is caustic and not safe for this use).
- If toilets cannot be flushed, remove water from the bowl, stuff with a rag and line it with a heavy-duty plastic bag. After use, add a small amount of deodorant or disinfectant. When bag is full, securely tie the bag, and dispose of it in a large trashcan with a tight fitting lid.
- Portable camp toilets, small trash cans or sturdy buckets lined with heavy-duty plastic bags are other alternatives for waste disposal.
- Large zip lock plastic bags and toilet paper should be kept at work and in the car for use if you are away from home.
- “Brief Relief” waste bags gel the waste and start to biodegrade it instantly.

## Storage Suggestions

Finding extra space to store your emergency supplies can be tricky. They will do you little good if you cannot get to them or if they are damaged during an emergency.

## Storage Tips

- If you have a camper or trailer, you may already have all the emergency supplies you need. Remember to restock so that your emergency home away from home is ready for emergencies.
- Perishable supplies will remain stable longer if they are stored in a cool, dark place.
- One method of storing emergency supplies is to place them in a large, covered garbage can, preferably plastic or rubber and on wheels. Put the contents inside a tightly closed plastic bag before placing them in the can.
- In a shed or other outbuildings, make sure that all supplies are up off cement floors (condensation will rust cans), and away from gasoline and chemicals that can contaminate your supplies.
- On a closet floor, behind a sofa, or under a bed preferably close to an exit.



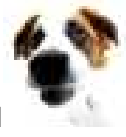

## Your Pets are Counting on You

Do you have a plan for your family pet in case of emergencies or disasters?

Having supplies and a plan before a disaster will give you peace of mind, save precious time and maybe even your pet's life.

Don't expect rescue centres to have supplies for your pets – this is your responsibility.

Designate someone to help you out if you are not home when a disaster strikes.

Have a recent photo and description of your pet(s) ready to help rescue workers find them.

### ✓ Pet Emergency Kit Checklist

<input type="checkbox"/> Food/water (7-day supply)	<input type="checkbox"/> Manual can opener
<input type="checkbox"/> Identification tag and collar	<input type="checkbox"/> Recent photos of your pet
<input type="checkbox"/> Sturdy crate and/or carrier	<input type="checkbox"/> Copy of your pet's current vaccination history
<input type="checkbox"/> Pet first-aid kit	<input type="checkbox"/> Any special medications & instructions
<input type="checkbox"/> Leash and harness	<input type="checkbox"/> Emergency phone numbers & addresses (pet friendly hotels, emergency vet clinic, local animal shelter, boarding kennels, etc.)
<input type="checkbox"/> Non-spill bowls	
<input type="checkbox"/> Litter box & litter for cats	

### During a Disaster

Try your best to take your pet with you. If this is NOT possible when you evacuate, follow these guidelines to help ensure your pet's safety:

- Prepare a poster of your pets with pictures and descriptions (update as needed) and post in a window to let rescue workers know how many pets were left behind.
- Leave plenty of water in a large tip-proof container inside and outside your home.
- Leave dry food in timed feeders (check local pet stores) to prevent your pet from eating a week's worth of food in one day.
- Do not tether or cage pets as chances of survival are greater if they can escape easily.

### Finding Your Pet Following a Disaster

- When it's safe, return to your neighbourhood to search for your pet and distribute "lost pet" posters.
- Ask neighbours, mail & newspaper carriers, joggers & others to look out for your pet.
- Check in with your local animal shelter (if there is one) to report your pet missing. They may have already rescued your pet.
- Don't give up, sometimes lost pets turn up months after they have gone missing.

## Emergency Planning for Farm Animals



Do not wait until the last minute to start evacuating.

The more animals you have, and the larger they are, the more you need to be ready to evacuate them at the first sign of danger. If you wait too long, you may not be able to move the animals or you may run out of time and be forced to leave them behind.

Do not leave animals behind when you evacuate, even if you are not sure where to take them.

Once you evacuate, it is unlikely you will be allowed to return to your home to retrieve any animals left behind. When you get your animals to a safe area there are bound to be individuals or animal organizations there to help you care for your animals.

Have a safe and secure way to transport your animals when evacuating them.

When evacuating animals, remember that they will be frightened. Given a chance, they will try to get away and find a place where they feel safe. Keeping animals securely confined will minimize the chance of you losing your animals.

What if you were not at home when a disaster struck and your animals were alone?

It's a horrible thought, but it could happen, so you need to have a plan. The first place to start is to talk with neighbors that you know and trust. If they too have animals, discuss what you could do to help one another. A neighborhood pet sitter or dog walker might be another alternative. Here are some of the points you should discuss:

1. What time of the day are you most often gone?
2. What days of the week are you most often gone?
3. List all your animals, including their names and any behavioral problems they may have.
4. Have your backup person spend time with your animals so they feel mutually comfortable with one another.
5. Make each other aware of where such things as transport cages, gloves, leashes, halters and lead ropes are kept.
6. Exchange phone numbers including: work, cell phone, pager and emergency contact person outside the area where messages can be left.
7. Exchange keys or any security codes (remember to only do this with people you trust)
8. Establish a meeting point outside of a likely evacuation area
9. Discuss what should be done if animals cannot be evacuated - the most likely alternative being to turn them loose

# Emergency Preparedness for Your Home

## Top 5 Recommendations:

1. Install smoke and/or carbon monoxide alarms to save lives!
2. Practice fire drills with your whole family.
3. Secure your hot water tank to the studs with steel strapping (see page 21).
4. Secure furniture and contents (see page 22). Use Velcro strips or putty to secure picture frames and mirrors (see page 23).
5. Only shut off fuel oil or propane gas if you smell it.

As much as 1/3 of all reported emergency loss is caused by non-structural damage to building contents that is relatively easy to prevent. Preparing your home is well worth the investment because of the huge losses it can prevent.



This section of the workbook will:

- Provide a Home Hazard Hunt (risk assessment) to help you determine what needs to be done to make your home safer in an emergency.
- Offer step-by-step guidelines for securing the contents of your home.
- Explain how you can help ensure that your home is structurally sound.
- Teach you how and when to shut off any utilities.
- Outline the basic steps of fire prevention.

## Emergency Information

Listen to local media such as: CBC Radio FM 95.7, CJRL MI X FM 89.5, CFOB FM 93.1, CKSX FM - 91.1 to get timely information updates during an emergency/disaster.

## Home Hazard Hunt (Risk Assessment)

Do you believe that your home is a safe place to be?  
 Statistics show that most fires, accidents and injuries occur in the home.

An important step in family preparedness is to identify the hazards in your home. It doesn't take much time or effort to make your home a safer place to live.

Getting Started: Involve your whole family, especially your children in a home hazard hunt. Remember that anything that can move, break, fall or burn is a potential hazard. Foresight, imagination and common sense are the only tools you will need! After identifying what needs to be done, devise a plan to do it.

Yes	No		Fixed
		Keep cooking areas clean and clear of combustibles	
		Ensure electrical outlets near water are Ground Fault Interrupt (GFI) equipped	
		Secure hot water heater to studs (page 21)	
		Secure tall furniture (page 22)	
		*** Keep heavy objects down low or secured (page 22)	
		Secure electronic equipment and small appliances	

\*\*\* If these objects are not secured, everyone in your home must be made aware of the potential danger during an emergency. \*\*\*



Yes	No		Fixed
		Secure mirrors and framed pictures (page 23)	
		Secure hanging plants and lights (page 23)	
		Secure kitchen, bathroom and storage cabinet doors (page 23)	
		Secure chemical hazards (page 34)	
		Ensure that your home is bolted to its foundation (page 18)	
		Strengthen cripple walls (page 18)	
		Secure chimney, roof and attic spaces (page 20)	
		Identify utility locations and determine shut off options (pages 24 - 26)	



Congratulations for making your home a safer place to be!

## Making Your Home Structurally Safe

Homes that have been framed in wood are generally quite resistant to storm damage. Watching tall trees in a strong wind demonstrates this resistance. It is unlikely that conventionally framed houses will collapse. This is the case, however, only if the home remains on its foundation and the roof, ceiling and walls remain connected.

### Foundation

- Check your house and garage for foundation bolts. It is strongly recommended that your home be inspected to ensure anchor bolts have been properly installed to secure the wood structure to the concrete foundation. They are typically spaced every 6 feet (~6 feet) apart along the sill plate and should look like the one shown in the diagram.
- Using a hammer drill and carbide bit, drill a hole through the sill plate into the foundation. Place these holes every 6 feet (~6 feet).
- Drop a 1/2" x 8" expansion bolt into the hole and finish by tightening the nut and washer.

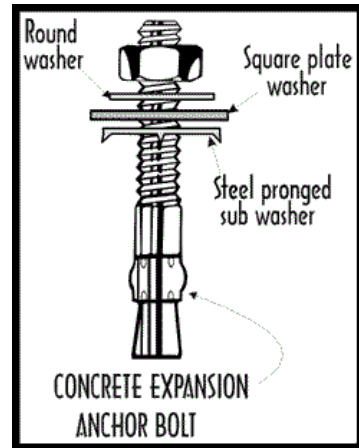

have  
cure  
trees

### Cripple Walls



Vertical studs that extend from the foundation to the first floor of your home are called cripple walls. If they are exposed on the inside, they could buckle with wind.

- Strengthen the cripple walls by nailing plywood sheeting to the vertical studs.
- Inspect the garage for exposed cripple walls. This is particularly important if the garage is supporting living quarters.

## Mobile Home Foundations

It is relatively easy for a mobile home to be thrown off its supports during a storm event.

- Leave the wheels on the coach to limit its fall.
- Check the undercarriage to make sure that it has been securely tied to the foundation.
- Tie doublewide mobiles together. The two halves generally are of different weights. Because of this, they move differently in an wind storm and can easily pull apart.

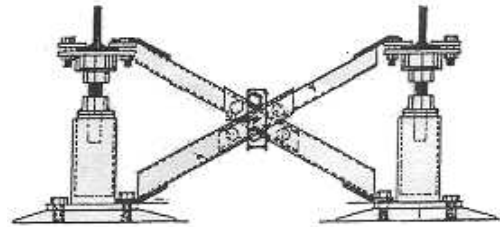

## Strengthening the Frame

For a building to stay together in a wind storm, all its parts must be fastened together. Metal connectors (brackets) are used to strengthen places where the posts and beams of the walls, and the floor and ceiling join.

- Strengthen the connection between ceilings, walls and floors using the appropriate hardware:

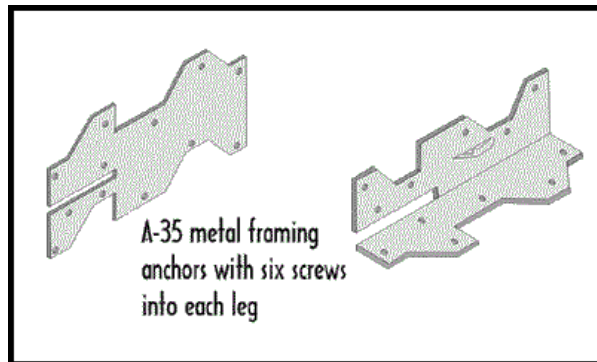

- Inspect all exposed framing in garages, basements, porches and patio covers. Strengthen this where necessary.

## Brick and masonry

- Brick, masonry and stone facades are very susceptible to tornado or wind damage. Family members need to keep away from such facades. If you have a large amount of brick or stone in your home you may want to consult a structural engineer for advice on how to secure it.

## Chimney

One of the most common types of damage suffered is a toppled chimney. This becomes extremely dangerous when bricks penetrate the roof and fall to the rooms below.

- Check the chimney for loose tiles and bricks.
- Reinforce the ceiling surrounding the chimney with  $\frac{3}{4}$ " plywood nailed to the beams. This will provide protection from falling bricks that might break through the roof.

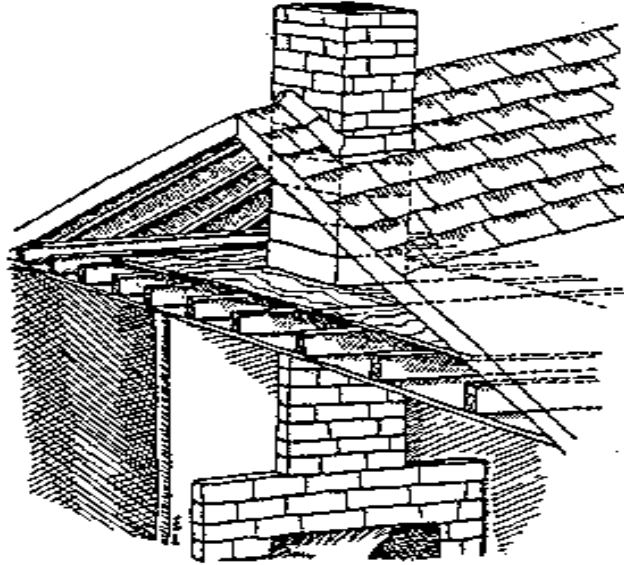

## Windows

Windows are a major hazard in a tornado. As the building moves, pressure builds up on the windows which may result in them shattering.

- Consider adding a safety film to the inside (square feet) in size. This does not prevent glass from falling and injuring loved ones.
- Can be used on mirrors as well to keep them from shattering during an tornado



## Securing the Water Heater

A typical water heater weighs between 200 to 400 kilograms when full. A sudden jolt and/or the rolling motion that can accompany a tornado can cause them to topple over. This movement can also cause the propane gas and water line connectors to break.

- Wrap a 1 ½" wide, 16 gauge thick metal strap around the top of the water heater and about 1/3 of the way up from the bottom. Bolt the ends together.
- Take four lengths of EMT electrical conduit, each no longer than 30 inches. Flatten the ends. Bolt one end to the metal strap as shown. Screw the other end to a 2" by 4" stud in the wall using a 5/16" by 3" lag screw (see illustration).

Once the appliance has been secured a flexible pipe may be installed to connect the gas supply. The installation of this pipe should only be carried out by a licensed gas fitter.

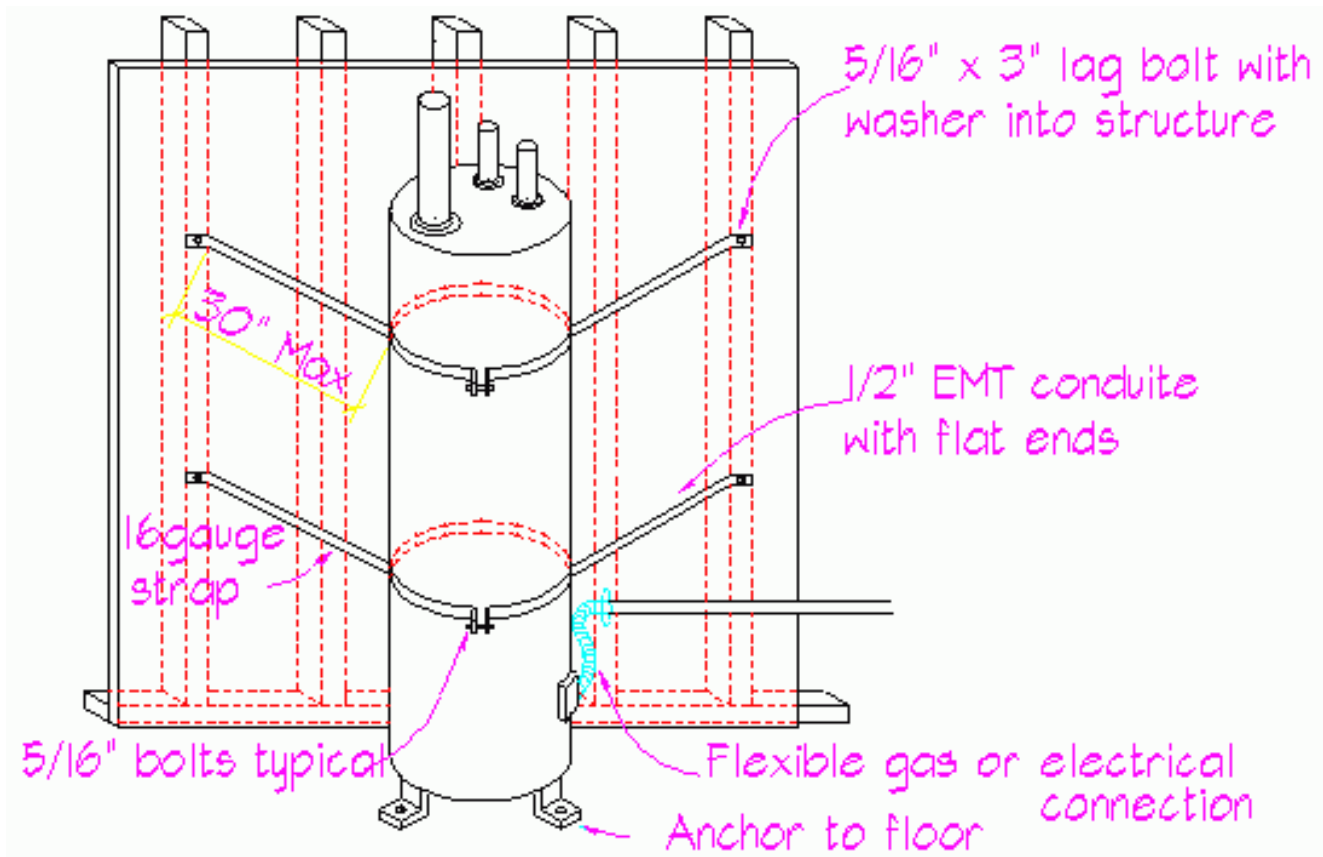

## Securing Furniture and Its Contents

A major tornado has the potential for causing substantial damage to your possessions. Approximately one-third of the cost of wind damage is due to non-structural losses like furniture, equipment, heirlooms, etc.

How you secure your furniture depends upon its value, location and your imagination. There are many ways to protect each piece.

- Secure all tall free-standing furniture, such as bookcases, china cabinets and shelving units to the wall studs using "L" brackets, corner brackets or anodized aluminium moulding. Examples are illustrated.
- Attach a wooden or metal guardrail to open shelves to keep items from sliding off. This is especially important wherever there are a lot of glass items.
- Place heavy and/or large items on lower shelves.

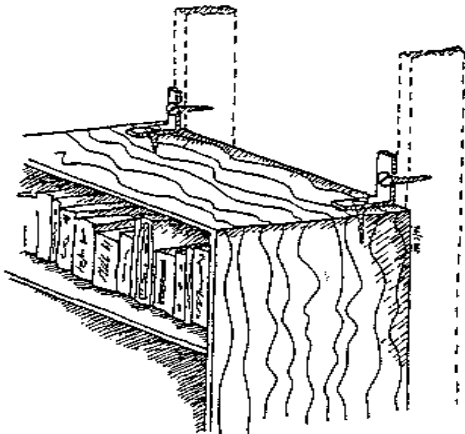

### Securing Items to Shelves or Countertops

Secure items such as televisions, stereos, computers, microwaves and breakable collectibles with Velcro, putty, dental wax or double-sided tape.

- Choose Velcro with adhesive on the back and cut into 1" squares.
- Leaving the two sides of the Velcro together, remove the paper to expose the adhesive on one side and attach this to the legs or corners of the equipment or appliance.
- Leaving the two sides of the Velcro fastened together, remove the paper from the other side and set the item down on the shelf or countertop where you want it placed.
- Lay a rubber strip across the front of shelves to help keep books and files from sliding forward.
- Line shelves with rubbery shelf liner that keeps items from sliding off the shelves.

## Securing Wood Burning Appliances

A typical wood burning stove or heater weighs between 100 and 150 kilograms. It can easily topple over from the rolling action of in a tornado. This movement can cause a fire or let smoke and other gases to leak into the house.

Have a professional secure your wood-burning appliance so it will not move or topple over. If you do the work yourself, have it inspected.

Do not compromise your safety!

## Securing Pictures, Mirrors, Hanging Objects and Cabinets

Tornados can knock pictures and mirrors off the walls.  
You may be seriously injured if they happen to fall on you.

Consider moving all framed pictures and mirrors away from beds, couches and chairs.

### Securing pictures and mirrors

- Place angle screws on their top and bottom or secure them with wire to anchor these directly into wall studs if possible.
- Poster Putty or Velcro may also be used in diagonal corners to secure pictures, mirrors, wall clocks, etc. to the wall.

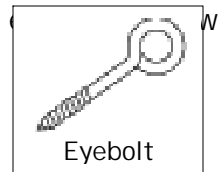

### Securing hanging objects

Carefully check the location of all hanging plants and other hanging objects. Determine if they are close enough to windows to strike them in the motion of a tornado. If they are, consider moving them.

- Secure these objects by closing the opening in their hook. Make sure the hook is screwed directly into a ceiling stud.

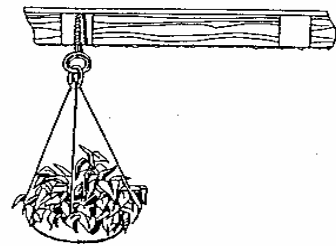

### Securing kitchen cabinets

- To prevent cabinet doors from flying open, install one of these types of latches.

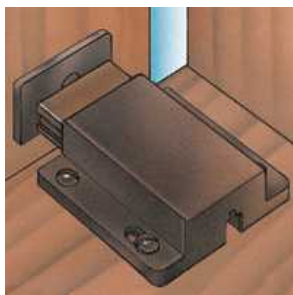

Push Latch



Pull Latch

## Shutting Off Propane Gas

Propane gas has a sulphur (rotten egg) odour added to it for detection. If leaked outdoors, it tends to rise and simply dissipate into the atmosphere. If leaked in a confined space, such as inside your home, it mixes with air and can cause a fire if ignited.

If you think you propane gas indoors:

- Open doors and windows
- Do not smoke, light matches or operate electrical switches
- Leave the premises
- Turn off your gas valve. Keep a dedicated wrench (12 to 16 inches long) in an easily accessible and safe location known to all family members
- Go to a nearby phone (outside of gas leak area) and call your propane gas company or 9-1-1

If there is a strong smell of gas, if you hear the flow of escaping gas, or if gas is leaking from a broken or disconnected gas pipe:

- Leave the premises
- Go to a nearby phone and call 9-1-1

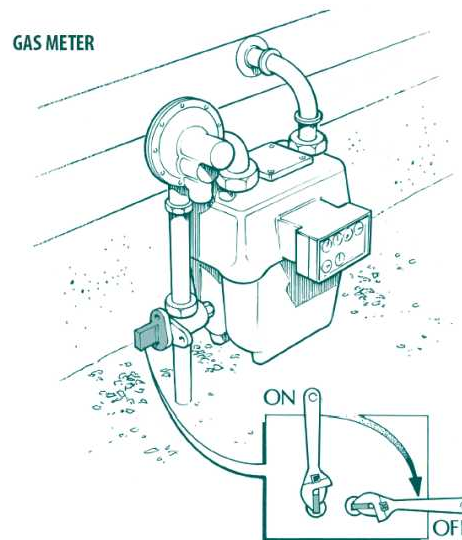
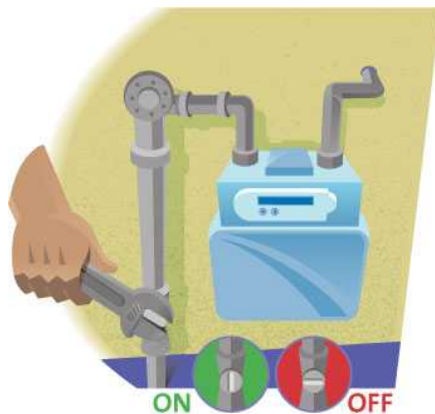

**DO NOT shut off gas unless you smell it (i.e. rotten egg odour). DO NOT turn gas back on as the system needs to be checked by a qualified technician.**



## Shutting Off Electricity

If power is disrupted during a disaster, turning off the main circuit breaker will also lessen the possibility of fire damage if no one is home when the power is restored.

- Locate the electricity circuit box. It may look like one of these:



Turn fuses to the left to unscrew.

- Turn the power off by flipping the individual circuits to the off position or unscrewing the fuses and finally flip the main breaker to the off position.
- When power is restored, turn circuits on as needed or as power comes back on.

### 7 Steps to Electrical Safety

Electricity is a part of our everyday lives and must be treated with respect. Everyone should know the 7 Steps to Electrical Safety. Learn them and pass them on. Remember, they don't call it power for nothing!

#### 1. Ten Metres to Safety

Stay back at least 10 metres (33 feet) from any fallen power line or exposed underground cable.

#### 2. Look up and live

Look up, check and keep equipment clear of overhead power lines.

#### 3. Know your limits

When using equipment in the vicinity of power lines, always maintain the limits of approach: from 3-7 metres (10-20 feet) depending on the voltage.

#### 4. Don't hang around operating equipment

Stay at least 10 metres (33 feet) from operating equipment, in case it contacts an energized line.

#### 5. Shuffle or hop - Don't Step

If your vehicle makes contact with an energized line remain inside until help arrives. If you must get out due to fire, jump out with your feet together without touching the vehicle. Then shuffle away, keeping both feet close together.

#### 6. Call before you dig

Avoid contacting underground power lines - before you dig, call 1 (888) 664-9376.

#### 7. Don't become a victim

Always call 9-1-1 when someone is injured in an electrical accident.

## If Someone Receives an Electrical Shock:

- Do not touch the person if she or he is still in contact with the source of electricity (the electricity will travel from their body into yours!).
- If there is a downed power line, keep people at least 10 metres (33 feet) away.
- Ask someone to call an ambulance and Hydro One while you stay with the victim.
- Once it is safe to do so, if the victim has no pulse, perform CPR.
- If the victim has been burned, avoid touching those areas or any burned clothing. You may gently apply cold water to burned areas until professional help arrives.

## Shutting Off Water

Water can very quickly become a precious and rare commodity following major emergency. It is important that all family members learn how to shut off the water for three reasons:

- The normal supply of water to your home will likely be disrupted or perhaps polluted because of broken or cracked lines. It is wise to shut the water supply off until you hear from the proper authorities that it is safe for drinking.
- Shutting off the water will trap the water that is in the hot water heater and toilet tanks. Not shutting the water off may allow it to flow back into the main water lines and no longer be available for your use.
- Shutting off the water supply will prevent water damage to your house if the pipes inside your home are broken during an event.

Locate the shut off valve for the water main in your house. It may look something like this:



- Make sure this valve can be completely shut off. Valves that have not been turned recently may be rusted open. Or they may only partially close. Replace this valve if necessary.
- Label this valve with a large tag and make sure that all family members know where it is located. (Turning off the water at the meter, usually located in a cement box, is not recommended because of the difficulty in turning this valve.)

## Protecting Your Home from Fire



### ✓ HOME FIRE SAFETY CHECKLIST (Simple changes that can save your life)

- Install smoke alarms on every level of your home. Place them on the ceiling outside bedrooms, in stairways, and near (but not in) the kitchen.
- Test and vacuum smoke alarms once a month and replace batteries every six months when the clocks change. Replace smoke alarms once every 10 years.
- Clean out storage areas. Do not let trash and recycling materials stack up.
- Plan & review escape routes with your family. Practice escaping from each room in the day time and in the dark (see page 29-30).
- Make sure windows can open and are not nailed or painted shut. Make sure security gratings on windows have a fire safety opening feature that can easily be opened from the inside.
- Consider escape ladders if your home has more than one level.
- Teach family members to stay low to the floor (where the air is safer in a fire) when escaping from a fire.
- Gather family at a safe meeting place and wait for the fire department.



### Flammable Liquids (Gas, diesel, oil, benzene, naptha, etc.)



- Never use indoors.
- Never smoke near flammable liquids.
- Store in approved containers in well-ventilated storage areas.
- Safely discard all rags or materials that have been soaked in flammable liquids outdoors in a metal container.

### Heating

- Insulate chimneys and place spark arresters on top. The chimney should be at least 1 metre (~3 feet) higher than the roof. Remove branches hanging near the chimney.
- Be sure to fill kerosene heaters outside, and be sure they have cooled before filling.
- Keep portable and space heaters at least 1 metre (~3 feet) away from anything that can burn. Never leave heaters on when you leave home or go to bed.
- Use only the proper fuel and follow manufacturer's instructions.
- Store ashes in a metal container outside and away from your residence.
- Keep a screen in front of the fireplace.
- Have heating units inspected and cleaned annually by a certified specialist.

## Electricity

- Have the electrical wiring in your residence checked by an electrician.
- Inspect extension cords for frayed or exposed wires or loose plugs.
- Make sure outlets have cover plates and no exposed wiring.
- Make sure wiring does not run under rugs, over nails, or across high-traffic areas.
- Do not overload extension cords or outlets. If you need to plug in two or three appliances, get a UL-approved unit with built-in circuit breakers to prevent sparks and short circuits.
- Make sure insulation does not touch bare electrical wiring.
- Sleep with your door closed.
- Install A-B-C-type fire extinguishers in your residence and teach family members how to use them.
- Consider installing an automatic fire sprinkler system in your residence.
- Ask your local fire department to inspect your residence for fire safety and prevention.



## Clothes Dryer Safety Tips

- DO clean the lint screen/filter before or after drying EACH load of clothes.
- DO clean the dryer vent and exhaust duct periodically.
- DO have a certified service technician clean and inspect the dryer and venting system regularly.
- DO replace plastic or vinyl exhaust hoses with rigid or flexible metal hoses to provide maximum airflow.
- DO keep the area around the dryer clean and free from clutter.
- DON'T place clothing or fabric stained with a flammable substance, such as alcohol, cooking oils, gasoline, spot removers or motor oil, in the dryer. Flammable substances give off vapors that could ignite or explode. Instead, dry the materials outdoors.
- DON'T forget to read the manufacturer warnings in the user manual and on the inside of the dryer door.
- DON'T dry any item containing foam, rubber or plastic, such as bathroom and non-slip rugs and athletic shoes.
- DON'T dry any item that contains glass fiber materials, such as a blouse or sweater with glass buttons or decorations.
- DON'T overload the dryer with wet clothes.

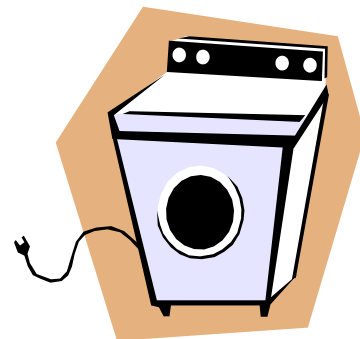

## Fire Safety

### Exit Drills In The Home

People can survive even major fires in their homes if they are alerted to the fire and get out quickly and stay out.

### How To Survive

- Install smoke detectors and keep them in working order.
- Make an escape plan and "practice" it.
- If your smoke detector is more than 10 years old, it may need to be replaced.

### Plan Your Escape

Once a fire has started, there is no time to plan how to get out. Sit down with your family today, and make a step-by-step plan for escaping a fire.

Draw a floor Plan of your Home, marking two ways out of every room - especially sleeping areas. Discuss the escape routes with every member of your household.

Agree on a Meeting Place, where every member of the household will gather outside your home after escaping a fire to wait for the fire department. This allows you to count heads and inform the fire department if anyone is missing or trapped inside the burning building.

Practice your escape plan at least twice a year. Have a fire drill in your home. Appoint a monitor, and have everyone participate. This is not a race. Get out quickly, but carefully.

### Make Your Exit Drill Realistic

Pretend that some exits are blocked by fire, and practice alternative escape routes. Pretend that the lights are out and that some escape routes are filling with smoke.

Be Prepared - Make sure everyone in the household can unlock all doors and windows quickly, even in the dark. Windows or doors with security bars need to be equipped with quick-release devices, and everyone in the household should know how to use them.

If you live in an apartment building, use stairways to escape. NEVER use an elevator during a fire. It may stop between floors or get stuck. Some high-rise buildings may have evacuation plans that require you to stay where you are and wait for the fire department.

If you live in a multi-storey house and you must escape from an upper story window, be sure there is a safe way to reach the ground, such as a fire-resistant fire escape ladder. Make special arrangements for children, older adults and people with disabilities. People with mobility challenges should have a phone and, if possible, sleep on the ground floor.

Test doors before opening them - While kneeling or crouching at the door, reach up as high as you can and with the back of your hand touch the door, the knob, and the crack between the door and its frame. If you feel any warmth at all, use another escape route. If the door feels cool, open it with caution. Put your shoulder against the door and open it slowly. Be prepared to slam it shut if there is smoke or flames on the other side. Close it behind you as you leave.

If you are trapped, close all doors between you and the fire. Stuff the cracks around the doors to keep out smoke. Wait at a window and signal for help with a flashlight or by waving a light colored cloth. If there is a phone in the room, call the fire department and report exactly where you are.

### GET OUT FAST . . .

In case of a fire, don't stop for anything. Do not try to rescue possessions or pets. Go directly to your meeting place, and then call the fire department from a neighbor's phone, a portable phone, or an alarm box. Every member of your household should know how to call the fire department.

Crawl low under smoke.

Smoke contains deadly gases, and heat rises. During a fire, cleaner air will be near the floor. If you encounter smoke when using your primary exit, use an alternative escape route. If you must exit through smoke, crawl on your hands and knees, keeping your head 30 - 60 centimeters (12 to 24 inches) above the floor.



and

### . . . AND STAY OUT

Once you are out of your home, don't go back for any reason. If people are trapped, the firefighters have the best chance of rescuing them. Firefighters have the training, experience, and protective equipment needed to enter burning buildings.

### Play It Safe

Install Smoke Detectors. With smoke detectors, your risk of dying in a home fire is cut nearly in half. Install smoke detectors outside every sleeping area and on every level of your home, including the basement. Follow installation instructions carefully, and test smoke detectors monthly. Change all smoke detector batteries every 6 months when the clocks are changed. If your detector is more than 10 years old, replace it with a new one.

Automatic fire-sprinkler systems.

These systems attack a fire in its early stages by spraying water only on the area where the fire has begun. Consider including sprinkler systems in plans for new construction and installing them in existing homes.

NOW, use what you've learned, SET UP YOUR PLAN, including two ways place and CONDUCT A PRACTICE DRILL to determine if anything has b EVERYONE in the household NEEDS TO PARTICIPATE for it to be succ SAVE YOUR LIFE.



eting  
ked.  
may

## Protecting Your Home from Forest Fire

- Mark your property entrance with address signs that are clearly visible from roads and back alleys.
- Keep lawns trimmed, leaves raked, and the roof and rain gutters free from debris such as dead limbs and leaves.
- Stack firewood at least 10 metres (33 feet) away from your residence.
- Store flammable materials, liquids, and solvents in metal containers outside your residence at least 10 metres (33 feet) away from structures and wooden fences.
- Create defensible space by thinning trees and brush within 10 metres (33 feet) around your residence. Beyond 10 metres (33 feet), remove dead wood, debris, and low tree branches.
- Landscape your property with fire resistant plants and vegetation to prevent fire from spreading quickly. For example, hardwood trees are more fire-resistant than pine, evergreen, eucalyptus, or fir trees.
- Make sure water sources, such as hydrants, ponds, swimming pools, and wells, are accessible to the fire department.
- Use fire resistant, protective roofing and materials like stone, brick, and metal to protect your residence. Avoid using wood materials. They offer the least fire protection.
- Cover all exterior vents, attics, and eaves with metal mesh screens no larger than 6 millimeters or 1/4 inch to prevent debris from collecting and to help keep sparks out.
- Install multi-pane windows, tempered safety glass, or fireproof shutters to protect large windows from radiant heat.
- Use fire-resistant draperies for added window protection.
- Have chimneys, wood stoves, and all home heating systems inspected and cleaned annually by a certified specialist.
- Insulate chimneys and install spark arresters in chimneys and stovepipes. The chimney should be at least 1 metre (~3 feet) above the roof.
- Remove branches hanging above and around the chimney.



Before burning debris in a wooded area, check with local authorities whether burning is allowed, obtain a burning permit if applicable, and follow these guidelines:

- Use an approved incinerator with a safety lid or covering with holes no larger than 3/4 inch.
- Create at least a 3 metre (~10-foot) clearing around the incinerator before burning debris.
- Have a fire extinguisher or garden hose on hand when burning debris.

## Protecting Your Home from Flooding

To minimize flood damage to your personal property and disruption of your day-to-day life, there are certain precautions you may take. Contact your local government for specifics relating to the incident affecting you.



If your home is located near a creek, river, lake or ocean, check with your local government office to determine if your property is located in a known "flood plain." If that is the case, you will need to take additional precautions which are outlined in the booklet "Flood Proofing Your Home" that is available through your local government offices or at [www.emergencymanagementontario.ca/english/prepare/specific/specific.html](http://www.emergencymanagementontario.ca/english/prepare/specific/specific.html).

These precautions are your responsibility to undertake.

### When Flooding is Imminent:

#### Wrap Your Home in Polyethylene Sheeting

Wrap the exterior lower levels of your home with polyethylene sheeting to provide extra protection to your home's structure. Use sandbags to secure the base of the sheeting and brace the structure with 2" by 4"s and sandbags.

#### Shut Off Electrical Power

Shut off all electrical power by shutting off the main power breaker to your house and outbuildings. In suburban or rural areas the yard switch must be opened.

#### Shut Off Propane Gas or Oil Fired Appliances

Shut off the gas supply valve to all appliances. These valves are usually in the gas line near the bottom of the appliance.

#### Turn Off Propane Tanks

Turn off the valve at the tank. Disconnect tubing to tank and securely plug it. Fasten a cable, heavy rope or chain around the tank and secure the other end to a pole, building or substantial structure to prevent the tank from floating away.

Once the flood waters have gone down, have the tank safely re-installed and connected to the appliances. Do not attempt to do the re-connection yourself.

#### Remove Chemicals to Dry Area

Dangerous chemicals such as weed killer, insecticides and corrosives should be removed to dry areas to reduce the dangers of contamination, fires, explosions and personal injuries.



#### Remove Valuables from Basements and Lower Floors

Furnishings and items stored in basements may be ruined by flood waters and where possible should be removed to higher floors.



## SANDBAG DYKES

If you choose to construct a sandbag dyke to protect your property, you will need to follow specific steps to ensure that it is effective.

Dig a trench one sack deep and two sacks wide as a foundation for the dyke structure.

To effectively resist the forces of flood water, a dyke needs to be 3 times as wide at its base as it is high. For example, a 1 metre (~3 feet) high dyke needs to be 3 metres (~10 feet) wide at the base.

Fill sandbags only half-full and lay them in alternating crisscross directions. The base level should be laid in the same direction as the water flow, the second level should be laid perpendicular to the direction of the water flow, and continue laying the bags in alternate directions. Each layer needs to be set back one-half sandbag width on both sides from the previous layer so that the cross-section looks like a triangle.

Individual bags need not be tied shut. Overlapping the bags will hold the sand in place.

Tamp each bag firmly into place, to ensure that the finished dyke works properly.

Sandbags are available from your Municipal Fire Rescue Service.

### RECOMMENDED METHOD FOR SANDBAG DYKING

Bags Required for 100 Linear Feet of Dyke	
Height Above Dyke	Bags Required
1/3 metre	600
2/3 metre	2000
1 metre	3400

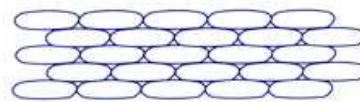

PLAN OF BOTTOM LAYER



METHOD OF LAPPING SACKS

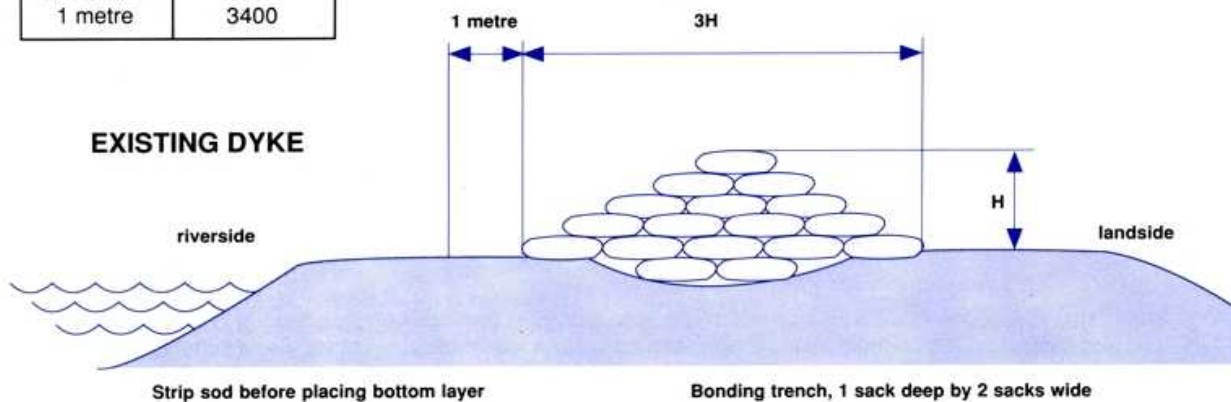

1. Alternate direction of sacks with bottom layer, i.e. bottom layer lengthwise with dyke, next layer crosswise.
2. Lap unfilled portion under next sack.
3. Tying or sewing of sacks not necessary.

4. Sacks should be approximately one-half full of clay, silt or sand.
5. Tamp thoroughly in place.

## Hazardous Materials Safety

Improperly stored chemicals can create a secondary disaster following a major emergency. Care must be taken to store them properly now.

- Keep only those chemicals you need and use on hand. Dispose of old or unwanted chemicals at a designated collection depot.
- Place pesticides, gasoline, paint thinners, and other chemicals in a locked cabinet. It should also be away from children's play areas.
- Chemicals should be stored well away from any water or food storage items.
- Make sure container lids are tightly closed.
- Store ammonia and bleach in different locations. If mixed, they create toxic fumes.



### Shelter In Place

- If there is a Hazardous Materials Spill in your area, you may be instructed to Evacuate or Shelter In Place (see pages 38 – 41 of this workbook).

# Responding Safely During Emergencies

Top Recommendations:

1. Always take the time to check for hazards around you or where you are trying to move to before taking action
2. To extinguish fire on your clothing, Stop, drop and roll
3. Close doors when exiting a building during an emergency
4. Stay Calm so you can think clearly

This section of the workbook will outline:

- Ways to prevent injury and stay safe
- What to do for specific hazards
- Where to seek shelter from all types of hazards
- What you should do after an emergency or disaster.

## Emergency Information

Listen to local media such as: CBC Radio FM 95.7, CJRL MI X FM 89.5, CFOB FM 93.1, CKSX FM - 91.1 to get timely information updates during an emergency/disaster.

## EVACUATIONS/SHELTERING IN PLACE

This section is for information purposes only. During an evacuation, emergency personnel will contact you and supply further instructions (what to do, where to go, etc.)

They may alert you by several methods including:

- Personal Contact (emergency personnel door-to-door)
- Public Address System (PA's)
- Local TV, Radio, and News Media Broadcasts
- Outdoor Alerting Systems (siren, horn, etc.)
- Cable TV Interrupts
- Telephone Systems (manual or automatic dialling systems)



### Get Ready to Leave

- Stay Calm.
- Gather your family, take a neighbour or someone who needs help.
- If evacuation is mandatory: take critical items (medicine, purse, wallet, keys, etc.) if they are immediately available. Take pets in pet kennels or on a leash.
- If evacuation is precautionary: take essential items (diapers, baby food, clothes, money, etc.).
- Leave a radio on, preferably a "talk radio" station. This gives the impression of an occupied home and is a good deterrent to criminals.
- Turn off all appliances (stove, washing machine, etc.)
- Do not turn off your utilities (gas, water, electricity) unless instructed to do so. If you do, do not turn them on unless you consult the proper utility authority.
- Lock your house.
- Do not use more cars than you have to.
- If there are problems with air quality, keep windows and vents in the car closed.

You can get detailed information on burglar-proofing your house from your local Police Department (see contact information at the front of your local phone book).

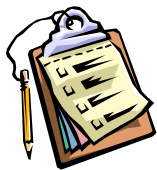

Start now (before the disaster) to make a list of important and irreplaceable items that you want to protect or take with you should you have to evacuate. Planning ahead saves valuable time and ensures that the things that really matter to you are taken care of.

## Evacuation Information and Procedures

Evacuations can be chaotic, nerve wracking and a time of worry and strain. Make yourself aware and be prepared. Fire fighters and other emergency personnel cannot work on the fire or other problems until life and safety issues are under control - that means YOU! Resisting evacuation consumes the rescuers precious time. Once you receive the information of the Evacuation Order, evacuate immediately. Delay can result in roadways being blocked by smoke, other materials or rescue equipment. Listen to emergency broadcasts and follow the directions of emergency personnel.

**Be Prepared, Informed, And Organized. Be Safe.**

Whether you need to leave your home due to a quickly approaching fire, or because of rising flood waters, you should be aware of Evacuation Alerts and Orders, what they mean, and how to prepare yourself and your family. Depending on the nature of the emergency, Ontario has several legal Acts which authorize evacuations.

Evacuations are an incremental process that can be implemented more efficiently if people are informed and keep tuned into local media for information releases. (See Emergency Information at the beginning of each workbook section for radio stations in your area.)

### Evacuation Stages

Regardless of which legal authority orders an evacuation, warning and implementation should follow the provincial standard of a three-staged process.

#### Stage 1 - Evacuation Alert

Alerting the population at risk of the impending danger. At this point, the movement of handicapped persons, transient population, including vacationers, and in some cases, school population, and any voluntary evacuees, should become a priority.

#### Stage 2 - Evacuation Order

Leave the area now! All persons in the affected area will be told that, in the interest of their own safety and considering the risk, they are now ordered to leave the area. There is no discretion allowed in the Order, which clearly indicates immediate evacuation and relocation. The OPP will enforce this Evacuation Order.



#### Stage 3 - Rescind



When the emergency is under control and the area is declared safe, the Evacuation Order will be rescinded and information will be broadcast to advise evacuees that they may return home. If the emergency reoccurs, another evacuation may be necessary starting at stage 1 and proceeding directly to stage 2 if the danger is imminent.

If you hear from a Media Information Release that an Evacuation is anticipated, be sure to note whether it is an Alert or an Order. How you respond is different for each stage, and important to remember. Following these guidelines helps first responders to help you more quickly and safely.



If an Evacuation Alert has been issued:

1. Take your Grab 'n Go kit or, if you do not have one, gather essential items such as medications, eyeglasses, valuable papers, immediate care needs for dependants, and valuable keepsakes. Include a couple of blankets and pillows. Be practical about what to take with you. Make them available for immediate access for a quick departure.
2. Keep track of the location of all family members and determine a planned meeting place should an evacuation be called while separated.
3. Immediately relocate large pets and livestock to an area outside of the evacuation alert.
4. Arrange accommodation for your family in the event of an evacuation. Emergency Social Services will be available to provide reception centres and emergency relief for periods of 72 hours.
5. Water vegetation adjacent to structures if water supplies and time permits.

If an Evacuation Order has been issued:

1. You **MUST LEAVE THE AREA IMMEDIATELY**. It is imperative that you report to the Reception Centre indicated. This will allow for effective communications for the evacuation team, Emergency Coordination Centre and other responders. Reporting to the reception centre facilitates contact with concerned friends or relatives, and assists in connecting separated family members.
2. If you need transportation to evacuate, advise the individual providing the notice of evacuation.
3. Close all doors and windows in your home. Leave gates unlocked and clear driveways for fire fighter access.
4. Keep a flashlight and portable radio with you at all times.
5. Follow the directions of emergency personnel and obey traffic control. Travel will be one-way only out of your area to allow emergency vehicles access. Re-admission is not permitted until the Order is lifted.

As information is received from the operational front lines, and examined for specific actions, the public will be kept notified of developments, level of evacuation awareness, location of reception centres and other important information.

If you hear about evacuation in other areas where you have family and/or friends, invite them to come stay with you – having a place to go helps people facing evacuation.



## Shelter in Place Instructions

An accident may cause a hazardous material to enter the air. Unless the hazardous material is flammable, emergency response professionals may tell you to stay protected indoors until you receive instructions to leave. This should only last for a few hours so listen to your radio for updates.



During an emergency, if you get an official media release or message stating that people in your area are Ordered to Shelter in Place, you should:



■ **Go inside.**



■ **Close all windows and doors.**



■ **Turn off ventilation systems (heating and air-conditioning, and fireplace dampers).**



■ **Go into a room with the fewest doors and windows and seal the room.**



■ **Stay in the room until told by the authorities that it is safe to come out.**

While inside, you should stay tuned to local television or radio for information updates and use telephones only to call 9-1-1 for emergencies. When the emergency has passed, ventilate the building thoroughly to bring in fresh, clean air.

Weather-stripped buildings slow the movement of air into them and any hazardous material that does enter is weakened when it mixes with the indoor air. It is imperative that you stay indoors, especially if you see a cloud, vapour, or smoke from the hazardous material outdoors or you can smell it indoors. You will be safer inside! If the danger persists for more than 2 - 3 hours local officials will consider evacuation of the area.

If you are Sheltering in Place, DO NOT:

- Risk your safety for your pets. If they are not inside, shelter in place without them.
- Leave your building or home until you receive notification that the danger has passed.

You should always try to have enough emergency supplies on hand to last you and your family for a minimum of 7 days. Check out the emergency preparedness information in this workbook or visit [www.emergencymanagementontario.ca](http://www.emergencymanagementontario.ca) for further information.



## FIRES

Having a fire extinguisher handy and knowing how to use it may save your home, your possessions and even your life. This is especially true following a major emergency when the fire department will be overwhelmed by the number of calls and may not be able to get to you in time. However, be smart. Knowing when the fire is too big to handle is equally important. Do not endanger yourself or your family by trying to save your home.

### Escaping a Fire

- Stop, drop, and roll—until the clothing fire is out. Running makes the fire burn faster.
- Check closed doors for heat before you open them. Use the back of your hand to feel the top of the door, the doorknob and the crack between the door and doorframe before you open it. Keep your hands safe to climb down ladders and crawl out to safety.

Hot Door	Cool Door
Do not open. Escape through a window or other exit.	Open slowly and ensure fire and/or smoke is not blocking your escape route.
If you cannot escape, hang a light-coloured sheet outside the window, alerting fire fighters to your presence.	If escape route blocked, shut the door and use another escape route, such as a window. If clear, crawl low under the smoke to exit.
Use a whistle to draw attention to your plight.	Close doors behind you as you escape to delay the spread of the fire.
Stay out. Do not reenter. Call 9-1-1.	Stay out. Do not reenter. Call 9-1-1.

### Fire Extinguishers



caking

Locate your fire extinguishers where they are readily accessible. When used correctly, they can keep small fires from becoming big ones.

- It is better to have several smaller extinguishers located throughout the house than to have one large one that may be difficult to get to quickly. This is especially important if your home has multiple floors.
- An A:B:C extinguisher is recommended for most types of fires.
- Regularly review their operating instructions as you won't have time to read them when a fire occurs.
- At least once a year turn your fire extinguisher upside-down, give the bottom a good smack and shake it to keep the chemical powder from



- Check your fire extinguisher's gauge to ensure the pressure is at the recommended level. (i.e. in the green zone - not too high and not too low).

Some manufacturers recommend shaking your dry chemical extinguishers once a month to prevent the powder from settling/packing.

Fire extinguishers should be pressure tested (a process called hydrostatic testing) after a number of years to ensure that the cylinder is safe to use. Consult your owner's manual, extinguisher label or the manufacturer to see when yours may need such testing.

**IMPORTANT:** Recharge all extinguishers immediately after use regardless of how much they were used.

Only fight a fire if:

- The fire is small and contained
- You are safe from toxic smoke
- If you have a means of escape
- If your instincts tell you it's okay

Using a fire extinguisher:

- Keep calm.
- VITAL: Keep an escape route open between you and the small fire you are attempting to extinguish. If the fire is large or becomes too large, immediately get out of the house. Close the door on your way out to slow the spread of the flames.
- Follow the four-step PASS procedure outlined below:

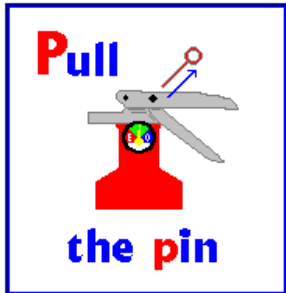

**Pull** the pin to unlock the lever.



**Aim** at the BASE of the fire to put it out.

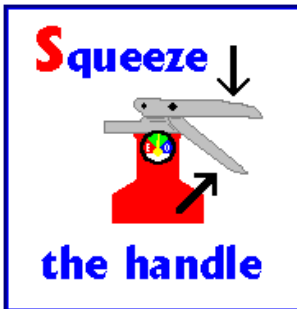

**Squeeze** the lever slowly to release the extinguishing agent. Release the handle to stop the discharge.



**Sweep** from side to side, moving carefully toward the fire, keep the extinguisher aimed at the base of the fire and sweep back and forth until the flames appear to be out.

Watch the fire area. If the fire reignites, repeat the process.

Call 9-1-1 anytime there is a fire in your home, even if you've put the fire out yourself. The fire department will ensure there are no lingering embers or hot spots that might erupt later and let you know about any necessary further precautions.

After a Fire

- Cool and cover burns to reduce chance of further injury or infection.
- Stay out of damaged buildings.
- If you are a tenant, contact the landlord.
- Do not try to open safe or strong boxes until they have cooled for several hours.
- If you must leave your home because a building inspector says the building is unsafe, ask for security to guard the property.
- Follow the instructions for recovering from a disaster (see page 56).



## FOREST FIRES

Forest fires do not just happen in remote areas. Urban and rural subdivisions, farms, acreage and cottages are all potentially threatened by forest fires. In Ontario, fires threaten or destroy many homes every year. Taking some basic steps will help reduce the threat of forest fires to your home and family.

### Before the Fire Approaches Your Home

- Evacuate. Evacuate your pets and all family members who are not essential to preparing your home. Anyone with medical or physical limitations and the young and elderly should be evacuated immediately.
- Remove combustibles. Clear items that will burn from around the house, including wood piles, lawn furniture, barbeque grills, tarp coverings, etc.
- Close or protect all openings. Close outside attic, eaves, fireplace and basement vents, windows, doors, pet doors, etc. Remove flammable drapes and curtains. Close all shutters, blinds or heavy non-combustible window coverings to reduce radiant heat.
- Close all interior doors and windows to prevent drafts.
- Shut off gas at the meter. Only a qualified professional may turn the gas back on.
- Turn off propane tanks and move them at least 10 metres (33 feet) from your home if possible.
- Connect garden hose to outside taps. Place lawn sprinklers on the roof and near above-ground fuel tanks. Wet the roof.
- Fill any pools, hot tubs, garbage cans, tubs or large containers with water.
- Wet or remove shrubs within 5 metres (~15 feet) of your residence.
- Gather fire tools such as a rake, axe, handsaw or chainsaw, bucket, and shovel.
- Face car in the direction of escape. Shut doors and roll up windows. Leave key in ignition and doors unlocked. Close garage windows and doors, but leave them unlocked.
- Disconnect automatic garage door openers so doors can be opened manually.
- Open fireplace damper. Close fireplace screens.
- Move flammable furniture into the center of the residence away from windows and sliding-glass doors.
- Valuables. Place important papers, mementos and anything "you can't live without" inside your car, ready for departure.
  - Lights - turn outside and inside lights on to make house more visible in heavy smoke.

If advised to evacuate, do so immediately. Follow the instructions provided and use the route determined in the evacuation notice. Watch for changes in the speed and direction of the fire and smoke.

### After a Forest Fire

Follow the instructions provided by local government and see page 61 for information regarding recovering from a disaster.

# FLOODS

It is important to be aware of your property's susceptibility and flood height forecasts for your area in order to be ready and prepared if a flood should occur.



## Before The Flood

- Make an inventory of your possessions, valuables, papers and property.
- Store valuable items on upper floors and keep all chemicals out of the basement.
- Learn safest route from your home or business to high, safe ground.
- Install check valves in sewer traps so flood water cannot backup in sewer drains.
- Be aware that high waters can cut off your return route.

## If You Must Leave Your Home:

1. Lock all doors and windows and double check to ensure gas and other heating fuel sources are turned off and that electricity and the water are shut off at the main valve or breaker leading to the house.
2. Remove insecticides and toxic chemicals from the house to prevent contamination.
3. Ensure that each member of your family has a blanket, warm clothing and waterproof outer wear. Take waterproof footwear for each family member.
4. Ensure each family member has identification, especially the young children. Name tags on clothing, wallet cards or wrist bands are all useful.
5. Seal all personal documents and family papers in plastic.
6. Take a supply of essential medications for each family member. You should always maintain a minimum two week supply of prescription drugs.
7. Carry all items necessary for the care and feeding of any infants in the family, including diapers, feeding bottles and foods.
8. Bring hand towels and toiletry items for each person.
9. Take an AM/FM transistor radio and a flashlight (preferably one that uses solar or windup so you don't have to depend on batteries).
10. Determine a location to move to before leaving and make sure each family member knows where it is. Provide younger children with a note sealed in plastic stating the family's destination. This will help the family reunite if separated for any reason.

## Flood Safety

Avoid floodwaters; water may be contaminated by oil, gasoline, or raw sewage. Water may also be electrically charged from underground or downed power lines.

Do not walk through moving water. Six inches of moving water can make you fall. If you have to walk in water, walk where the water is not moving. Use a stick to check the firmness of the ground in front of you.

Stay out of any building if it is surrounded by floodwaters. Use extreme caution when entering buildings; there may be hidden damage, particularly in foundations.

DO NOT visit a disaster area. Crowds hamper rescue and other emergency operations.

Do not drive into flooded areas. If floodwaters rise around your car, leave it and move to higher ground if you can do so safely. You and the vehicle can quickly be swept away.

### Driving in flood conditions:

Be aware of areas where floodwaters have receded. Roads may have weakened and could collapse under the weight of a car.

Take extra care when driving. Familiar roads will appear drastically different when covered by flood waters.

Be on the lookout for damaged bridges, slides and washouts and be particularly alert for downed power lines. Report these to the power company.

Be alert for emergency personnel and signs providing evacuation route directions.

Obey officials who are directing traffic or involved in rescue or flood control operations. They are there to assist you and to make sure the situation is handled safely and effectively.

### Did You Know?

- Six inches of water will reach the bottom of most passenger cars causing loss of control and possible stalling.
- A foot of water will float many vehicles.
- 60 centimetres or 2 feet of rushing water can carry away most vehicles including sport utility vehicles (SUV's) and pick-ups.

## Returning Home

DO NOT RETURN HOME until the local government announces the emergency situation is over and that it is safe to return to the affected area.

YOU MUST NOT LIVE IN YOUR HOUSE UNTIL:

- The regular water supply has been inspected and officially declared safe for use.
- Every flood-contaminated room is thoroughly cleaned, disinfected and surface-dried.
- All contaminated dishes and utensils have been thoroughly washed and disinfected, either by using boiling water or by using a sterilizing solution of 1 part chlorine bleach to 4 parts water; then rinse dishes and utensils thoroughly.
- Adequate toilet facilities are available.

For detailed information concerning the potential contamination of food stuffs contact your local health unit. DO NOT EAT FOOD that was submerged in flood waters.

Health officials recommend disposal of the following food stuffs:

- ALL FRESH OR DRIED FOODS
- CANNED GOODS (if damaged and showing signs of leakage)
- HOME CANNED OR BOTTLED FOODS (contamination can gather under caps)

## After the Flood

Have the house inspected for structural damage to ensure there is no danger of collapse.

Use extreme caution when entering buildings; there may be hidden damage, particularly in foundations. Wear rubber boots & gloves to avoid electrical shock and contamination.

If you notice a strong gas odour, do not enter. Call your local gas company immediately.

Let the building air out before entering to remove foul odours or escaped gas & do not heat above 4° C to reduce mould and bacteria growth.

If water occupies the home, pump out a third of the flooded water each day. Further damages to the structure can occur by pumping water out too quickly.

Add 2 litres of bleach to the remaining flood waters every 3 days to keep down the growth of bacteria and mould.

After flood damage, fuel oil/propane lines, equipment and appliances must be checked, and all leaks repaired and pressure tested by a licensed gas fitter.

DO NOT handle live electrical equipment in wet areas. DO NOT use electrical equipment exposed to floodwaters until it has been professionally checked and serviced.

Service damaged septic tanks, cesspools, pits, and leaching systems as soon as possible. Damaged sewage systems are serious health hazards.

Clean and disinfect everything that got wet. Mud left from floodwater can contain sewage and chemicals.



## HAZARDOUS MATERIALS

Industries and transportation use or carry many hazardous chemicals. Hazardous spills can occur anywhere. They can create a secondary disaster following an event such as a tornado or flood.

### Before A Hazardous Materials Spill

- Make plans now for ways to reunite with family members. (see page 3).
- Know where utility shut-off valves are and show everyone how to turn them off.
- Know where all in-take and exhaust fans for air conditioning and heating system are.
- Be prepared to evacuate the building if necessary.

### During A Hazardous Materials Spill

- Listen to the radio for instructions and information about a possible evacuation.
- For hazardous materials accidents, call 9-1-1, the local emergency notification number or the fire department.
- Stay away from the incident site to minimize the risk of contamination.
- If outside during an incident, try to stay upstream, uphill and upwind. Hazardous materials can quickly be transported by water and wind.
- Never move through a gas cloud. Travel cross-wind to avoid fumes.
- If in a vehicle, close windows and shut off ventilation. This will reduce the risk of contamination.
- If evacuation is necessary, follow the directions of emergency workers. Take emergency kit, medications and valuables, and leave a note stating destination.
- Follow the recommended evacuation route.
- If leaving animals at home, make sure all the doors and windows are closed and they have plenty of food and water. (refer to pages 13 & 14 for additional information.)
- If told to stay inside, close all doors and windows, sealing leaks with tape or wet towels. Turn off ventilation.

### After A Hazardous Materials Spill

- If evacuation is necessary, do not return home until local authorities say it is safe.
- Upon returning home, open windows and vents and turn on fans to provide ventilation.
- If you have been exposed to a hazardous material, follow decontamination instructions from local authorities. You may be advised to take a thorough shower or follow another procedure.
- Place exposed clothing and shoes in tightly sealed containers. Call local authorities to find out about proper disposal.
- Seek treatment for unusual symptoms as soon as possible.
- Find out from local authorities how to clean up your land and property.



## PANDEMIC S (DISEASE OUTBREAKS)

Disease outbreaks happen when a new kind of virus is able to spread easily from person to person and spreads quickly around the world. Since people have no protection against the new virus, it will likely cause more illnesses and a larger number of deaths than seasonal flu.

Influenza pandemics have happened every ten to forty years for at least the last 500 years. Three flu pandemics occurred in the last century, the last in 1968. The most severe known as the Spanish Flu was in 1918. No one can predict exactly when a pandemic will happen.

The flu spreads easily from person to person by:

- Breathing tiny droplets that are in the air after an infected person coughs or sneezes;
- Touching tiny droplets of nose or eye secretions from an infected person and then touching your eyes, nose or mouth; and
- Touching objects like dirty tissues or surfaces that have been handled by an infected person and then touching your eyes, nose or mouth.
- The flu virus can be spread off of hard surfaces like doorknobs for up to twelve hours, and from softer/porous surfaces, like hands and tissues, for several minutes.

The flu can be spread by an infected person from about one day before symptoms start to appear to as many as five days after symptoms appear, and maybe longer in children and some adults.

### Staying Healthy

- Have good routine health practices like eating well, getting enough sleep and exercising regularly.
- Wash your hands often and for at least 20 seconds with soap and warm water, and always after you cough or sneeze. An alcohol-based hand cleaner also works if your hands do not look dirty. This is one of the best ways to protect yourself from the flu!
- Practice good cough manners. Cover your mouth and nose with a tissue when you cough or sneeze, or cough into your upper sleeve if you don't have a tissue. Throw the used tissue into the garbage right away and wash your hands.
- Stay home if you are sick to make sure that you get the rest you need and so that you don't spread your germs to others.
- Stay away from people who are sick. You should especially try to stay at least 1 metre (~3 feet) away from people sick with the flu.
- Try not to touch your eyes, nose or mouth. This is a common way to spread or come in contact with germs.
- Avoid public gatherings and crowds.



It is recommended that you get a flu shot each year. Flu vaccine, when available, will be the primary public health intervention during a flu pandemic. The provincial government is working with the federal government and other provinces and territories to ensure that there will be enough vaccine for all Canadians. Since vaccine may not be available early in a pandemic, it is important to learn and use other ways to protect yourself and your family.

How can I care for myself during a disease outbreak?

During a disease outbreak, many people will be sick and it may be difficult to get medical care. For this reason, it is very important to be prepared to take care of yourself and others at home as much as possible.

Because you may need to be home for a time during the pandemic, it is a good idea to stock up on some basic supplies, such as food and water, for several days. Make sure you have two weeks supply of your regular medications on hand, and have a list of phone numbers for family, friends, neighbours, and your doctor.

Home treatment and self care can relieve most symptoms and reduce the risk for further problems. If you get the flu, ways to monitor and improve your health at home include:

- Stay home if you are sick to ensure that you get the rest you need and don't spread the virus to others.
- Drink lots of fluids including water, real juice, milk and herbal teas. It is best to have drinks without caffeine, because caffeine actually makes you lose fluid from your body.
- Use a hot water bottle or heating pad for short periods of time to help reduce muscle pain. Watch for burns and blisters.
- Get lots of rest.
- Take a warm bath with Epsom salts.
- Gargle with warm water and/or suck on sugarless hard candy or lozenges to ease your sore throat.
- Avoid alcohol and tobacco. Smoking especially irritates damaged airways.
- Avoid sharing anything that may carry germs such as towels, lipstick, cigarettes, drinks, or toys.
- Wash your hands often. Use soap and warm water for at least 20 seconds each time, or alcohol-based hand cleaners if your hands do not look dirty. This will help you avoid spreading the flu to others.
- Ask your pharmacist for advice if you buy over-the-counter medicine such as pain relievers or cold/flu medicines. Let the pharmacist know if you have any chronic medical problems.
- Call someone to help you until you are feeling better. This is especially important if you are alone, are a single parent or are responsible for the care of someone who is frail or disabled.

## During a Disease Outbreak

Always call your doctor and let him/her know about your symptoms before visiting, so that you don't infect other people at the office. If special clinics for people with the flu or flu-like symptoms have been set up, your doctor's office might ask you to go there instead.

In children, seek medical care right away if you notice any of the following:

- Fast or troubled breathing;
- Bluish or dark coloured lips or skin color;
- Drowsiness to the point that you cannot wake your child up;
- Severe crankiness, not wanting to be held;
- Not drinking enough fluids and/or not going to the bathroom (peeing) regularly (about every 6 hours when awake); or
- Symptoms improve and then suddenly become worse.

In adults, seek medical care right away if you have any of the following:

- Difficulty breathing or shortness of breath;
- Pain or pressure in the chest or stomach;
- Confusion or disorientation;
- Coughing up bloody sputum;
- Severe vomiting or vomiting that does not go away; or
- Symptoms improve and then suddenly become worse.

## Hand-washing Instructions

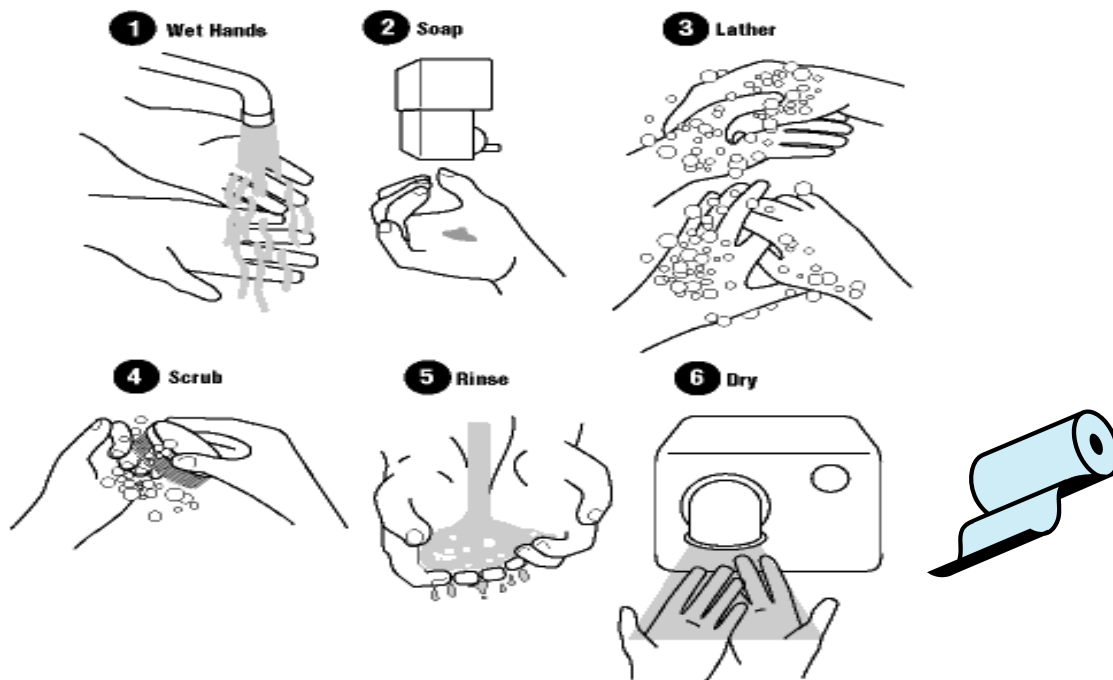

# POWER OUTAGES

When your power goes out, if your neighbours have power, check your fuse box or circuit breaker panel. Make sure large appliances are turned off before replacing fuses or throwing breakers. This will help prevent possible damage to your electrical system.

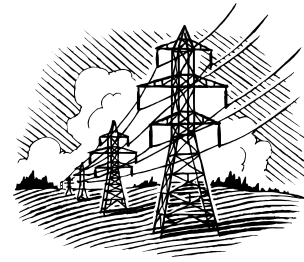

## Before the Power Outage

- People relying on life-sustaining equipment should contact their local health provider and consider purchasing or renting a small generator on a priority basis.
- Home Power Failure Lights are an inexpensive way to provide immediate emergency lighting during power failures.
- Consider alternate heating sources for your home so that you can stay warm during winter storms.
- Keep fuel for barbeques and camp stoves stored safely and use only outside.
- If you rely on power to pump water, make sure you have lots of extra water stored for use during power outages.
- Keep manual tools such as can openers around or choose cans with peel back lids. Keep dry goods and recipes for alternative cooking methods available for use when needed.
- If you have an electric garage door opener, learn how to open it without the electric power. Make sure to read the instructions supplied by the manufacturer.

## During a Power Outage

- Switch off appliances and tools with electronic controls (microchips) such as a stereo, television, VCR, microwave oven, stove, refrigerator, computer and light control system. This will help to avoid possible damage when the power comes back on.
- If you leave your home during the outage, double check to make sure all heat-producing appliances, such as your range and iron, are unplugged to minimize the risk of fire.
- Visually scan the neighbourhood to look for trouble indicators such as flashes of light and downed wires but make sure you keep away from these dangerous areas.
- Report the Outage using a regular phone (portable house phones won't work) to call the Hydro One 24-hour emergency number 1 (800) 434-1235 and give the operator as much information as you can. Please call only once, to keep phone lines open to other customers.
- Conserve water
- Keep doors, windows and drapes closed to retain heat

- Do not open freezers or refrigerators unless necessary.
- Be very careful of fire hazards caused by candles or other open flame light sources. Use a shiny aluminium pan behind the candle to reflect more light.
- If you have a fireplace, use it for both warmth and cooking but keep a window slightly open in the room in order to provide combustion air and ventilation.
- Use all barbeques, camp stoves and hibachis outside only.
- Keep a windup, solar or battery-operated radio on hand.
- Keep clear of wires or anything in contact with them and warn others of the danger. Always assume that wires are live and capable of killing people.

Warning: Do not use the burners or the oven in a gas stove to heat the kitchen. This is dangerous. A draft could blow out the oven pilot light on a gas stove, and maintaining too high an oven temperature for long periods of time could cause a fire.

If an extended outage occurs during cold weather, drain water systems and have an alternative heating system available that is not dependent on electricity. For example use a wood-burning fireplace, a gas fireplace or a portable kerosene heater. (Do not use a kerosene heater in an unattended room. Open a window slightly to provide combustion air and ventilation.)

#### Home Generators (MUST STAY OUTSIDE)

Home generators are handy for backup electricity in case of a service interruption or where no electrical service is available. To safely operate a generator, follow these steps:

1. Follow the generator manufacturer's instructions.
2. Connect lights, tools or appliances directly to the generator with standard CSA-approved extension cords. Never connect portable generators to the house wiring. This can cause dangerous feedback into the utility system.

#### AFTER A POWER OUTAGE

- When the power comes back on, give the electrical system a chance to stabilize. Turn on only the most essential appliances and wait 10 to 15 minutes before reconnecting others.
- If the outage lasts more than four hours in cold weather, it is helpful to reconnect the heating system and appliances gradually. For example, reconnect appliances over a 45-minute period after a 6-hour outage, reconnect over 2 hours after a 12-hour outage, and reconnect over 4 hours following a 24+ hour outage.
- Check to make sure the refrigerator and freezer are back on. Check whether food can be refrozen.
- Plug in appliances. Remember to reset clocks. Be sure to check automatic timers, alarms and smoke detectors.
- Restock emergency supplies.



## WATER SUPPLY INTERRUPTIONS

Water supply interruptions can arise without warning due to a variety of natural and man-made events. Many of us are used to annual water conservation measures that restrict water use during the summer months. Local governments are increasingly instituting more water conservation measures to conserve this valuable and necessary resource.

### Before the Water Supply Interruption

- Know how to shut-off the water line that enters your home.
- Store 20 - 35 litres of water per person to have enough to last you for at least seven days. Store water in sturdy, opaque plastic food grade pails, jugs or bottles (see pages 6 & 7 for more information).
- Keep canned goods and meals stocked that require little or no water to prepare.



### During the Water Supply Interruption

- Follow the instructions of local officials regarding water usage and purify water if necessary (see page 7 for general instructions).
- If a "boil water advisory" is issued, just boil the water for the number of minutes stated in the advisory, then let it stand and settle before using. You can then use it as regular tap water or filter it further through a coffee filter or paper towel if you prefer.

### Conserve water

- Keep a jug of water in the refrigerator for drinking
- When using big containers for small jobs like washing hands or brushing teeth, pour some water into a cup or glass and only use that amount rather than letting it pour straight from the big container.
- Wash essential clothing by hand only and wait to do laundry until the water supply is back in service.
- Turn off all garden sprinkler systems and selectively hand water only food plants as necessary. Use mulch and compost to reduce evaporation, promote plant growth and control weeds.
- Capture rainwater off the roof for use in your garden and for hygiene purposes.

### After the Water Supply Interruption

- Restock your water and food supplies.
- Have a brainstorming session to share things learned and get better prepared for the next time.
- Develop the habit of conserving water whenever you can.

## WINTER STORMS

Winter storms can create beautiful pristine landscapes and fun times for families to enjoy the outdoors but they also cause all kinds of challenges for travel with blocked driveways and roads and lengthy power outages.

### Before a Winter Storm

- Stock up on rock salt to melt ice on walkways.
- Keep sand or non-clumping kitty litter in your car trunk and at home to improve traction.
- Have snow shovels and other snow removal equipment on hand.
- Prepare for possible isolation in your home by having sufficient heating fuel. Prepare alternate sources of heat such as your fireplace or wood-burning stove.
- Winterize your home to extend the life of your fuel supply by insulating walls and attics, caulking and weather-stripping doors and windows, and installing storm windows or covering windows with plastic.
- Winterize your car before the season begins.
- Trim branches and dead trees to reduce the threat of trees falling onto your home, vehicle or power lines.
- Check the drainage around your house to reduce the flooding risk after a heavy rain.

### During a Winter Storm

- Check on your neighbours, especially the elderly and vulnerable. You may be their only resource.
- Wear several layers of loose fitting, lightweight, warm clothing rather than one layer of heavy clothing. The outer garments should be tightly woven and water repellent.
- Wear a hat and mittens which are warmer than gloves.
- Cover your mouth with a scarf to protect your lungs.
- Listen to local weather reports and stay tuned for emergency information.
- Eat regularly and drink ample fluids, avoid caffeine and alcohol that dehydrate.
- Avoid overexertion when shoveling snow. Stretch before going outside and again afterwards to keep from getting stiff and sore.
- Watch for signs of hypothermia - uncontrollable shivering, memory loss, disorientation, incoherence, slurred speech, drowsiness, and apparent exhaustion. Move person to a warm location, remove wet clothing, warm the center of the body first. Give warm, non-alcoholic, non-caffeine beverages if conscious. Get medical help as soon as possible.
- Watch for signs of frostbite - loss of feeling and white or pale skin in extremities such as fingers, toes, ear lobes, and the tip of the nose. Get medical help immediately.
- Conserve fuel, if necessary, by keeping your residence cooler than normal or closing off heat to some rooms temporarily.

- Keep a window open slightly when using kerosene heaters to avoid build-up of toxic fumes. Refuel kerosene heaters outside and keep them at least 1 metre (~3 feet) from flammable objects.



#### Vehicle Safety During Winter Storms:

- Drive only if it is absolutely necessary.
- Travel during the day, travel together with someone, and keep others informed of your schedule
- Stay on main roads and avoid back road shortcuts

If a blizzard traps you in the car:

- Pull to the side of the road. Turn on hazard lights and hang a distress flag from the radio antenna or window.
- Remain in your vehicle where rescuers are most likely to find you. Do not set out on foot unless you can see a building close by where you know you can take shelter. Be careful; distances are distorted by blowing snow. A building may seem close, but be too far to walk to in deep snow.
- Run the engine and heater about 10 minutes every half hour to keep warm. Periodically clear snow from the exhaust pipe to prevent carbon monoxide poisoning. Remember, you can't smell carbon monoxide fumes.
- Keep a window open slightly on the side away from the wind to allow fresh air into your car.
- Exercise to maintain body heat, but avoid overexertion. In extreme cold, use foil emergency blankets, road maps, seat covers, and floor mats for insulation. Huddle with passengers and use your coat for a blanket. A burning candle can provide much needed heat to keep you from freezing but contain it properly to prevent fires.
- Take turns sleeping. One person should be awake at all times to look for rescue crews.
- Drink fluids to avoid dehydration.
- Use lights, heat, and radio sparingly to conserve battery power.
- Turn on the inside light at night so work crews or rescuers can see you.
- If stranded in a remote area, stomp large block letters in an open area spelling out HELP or SOS and line with rocks or tree limbs to attract the attention of rescue personnel who may be surveying the area by airplane.

#### After a Winter Storm

- Check your home for storm damage.
- Make any necessary repairs.
- Restock all supplies so you are ready for the next time.



# Recovery (Moving Forward)

## Top 5 Recommendations:

1. Unfamiliar emotional responses are normal reactions to our emergency/disaster experiences
2. Recovery can take a long time (even years) so be kind to yourself and others as you work your way through this process
3. Help your children and pets learn to cope with their fears
4. Follow Health and Safety Guidelines throughout the recovery process
5. Attend community meetings or information sessions to find out what resources are available and how we can help each other



This section of the workbook will outline:

- Ways to start getting back on track after an emergency/disaster.
- Health and Safety Guidelines for when you return home.
- The normal emotional responses you may experience after an emergency/disaster.
- Where to begin looking for financial resources.

## Emergency Information

Listen to local media such as: CBC Radio FM 95.7, CJRL MI X FM 89.5, CFOB FM 93.1, CKSX FM - 91.1 to get timely information updates during an emergency/disaster.



## Getting Back on Track

Emergencies/disasters have a definite start and end. Coordinated response is required by individuals, agencies, local governments and communities to deal with the emergency or disaster. Every response has a definite start and end. Recovery starts at the same time as the response but will probably continue on for some time depending on the severity of the emergency/disaster.

1. Take care of yourself and your family first.
  - Attend debriefing sessions in your community that provide opportunities to get questions answered and for sharing our experiences
  - Promote physical health by eating healthy meals and getting exercise and fresh air
  - Promote emotional health by talking about our experiences with understanding family and friends or with a professional if you are struggling in any way
2. Take care of safety and security issues.
  - Contact your insurance company to start a claim and request security if your home is not able to be locked up
  - Stay with family and friends if possible as their support can be invaluable
  - Determine where you will live during the recovery
3. Assess the losses.
  - Start making a list of items and property that you have lost (identification, furniture, family keepsakes, etc.)
  - Find out if special precautions need to be taken before entering your home
  - Look for items that can be salvaged
  - Take time to appreciate what you still have
4. Determine what needs to be done.
  - Remove items you want to try and salvage
  - Have your home inspected to determine whether it can be repaired or needs to be removed and rebuilt
  - Find out when it will be safe to begin rebuilding or repairing
5. Determine recovery resources.
  - If a Recovery Centre been established this is a good place to find the agencies you need to work with
6. Start the recovery work.
  - Take care of yourself and your family first
  - Begin the process of rebuilding your lives and your residence

## Health and Safety Guidelines

Recovering from a disaster is usually a gradual process. Safety is a primary issue, as are mental and physical well-being. If assistance is available, knowing how to access it makes the process faster and less stressful. This section offers some general advice on steps to take after disaster strikes in order to begin getting your home, your community, and your life back to normal.

Your first concern after a disaster is your family's health and safety. You need to consider possible safety issues and monitor family health and well-being.

### Aiding the Injured

Check for injuries. Do not attempt to move seriously injured persons unless they are in immediate danger of death or further injury. If you must move an unconscious person, first stabilize the neck and back, then call for help immediately.

- If the victim is unresponsive, call 9-1-1.
- Care for life-threatening problems (ABCs) using CPR etc. as needed.
- Maintain body temperature with blankets. Be sure the victim does not become overheated.
- Never try to feed liquids to an unconscious person.

### Health

- Be aware of exhaustion. Don't try to do too much at once. Set priorities and pace yourself. Get enough rest.
- Drink plenty of clean water.
- Eat well.
- Wear sturdy work boots and gloves.
- Wash your hands thoroughly with soap and clean water often when working in debris.

### Safety Issues

- Be aware of new safety issues created by the disaster. Watch for washed out roads, contaminated buildings, contaminated water, gas leaks, broken glass, damaged electrical wiring, and slippery floors.
- Inform local authorities about health and safety issues, including chemical spills, downed power lines, washed out roads, smoldering insulation, and dead animals.



## Returning Home

Returning home can be both physically and mentally challenging. Above all, use caution.

- Keep a battery-powered radio with you so you can listen for emergency updates and news reports.
- Use a wind-up or battery-powered flashlight to inspect a damaged home.

Note: Turn the flashlight on outside before entering — the battery may produce a spark that could ignite leaking gas, if present.

- Watch out for animals.
- Use the phone only to report life-threatening emergencies.
- Stay off the streets. If you must go out, watch for fallen objects; downed electrical wires; and weakened walls, bridges, roads, and sidewalks.

## Before You Enter Your Home

Walk carefully around the outside and check for loose power lines, gas leaks, and structural damage. If you have any doubts about safety, have your residence inspected by a qualified building inspector or structural engineer before entering.

Do not enter if:

- You smell gas.
- Floodwaters remain around the building.
- Your home was damaged by fire and the authorities have not declared it safe.

## Going Inside Your Home

Enter the home carefully and check for damage. Be aware of loose boards and slippery floors. Check the following inside your home:

Fuel oil or Propane gas. If you smell gas or hear a hissing or blowing sound, open a window and leave immediately. Turn off the main gas valve from the outside, if you can. Call the gas company from another location to have the system inspected and repaired. Do not smoke or use oil, gas lanterns, candles, or torches for lighting inside a damaged home until you are sure there is no leaking gas or other flammable materials present.

Sparks, broken or frayed wires. Check the electrical system unless you are wet, standing in water, or unsure of your safety. If possible, turn off the electricity at the main fuse box or circuit breaker. If the situation is unsafe, leave the building and call for help. Do not turn lights on until you are sure they are safe to use. You may want to have an electrician inspect your wiring.

Roof, foundation, and chimney cracks. If it looks like the building may collapse, leave immediately.



Appliances. If appliances are wet, turn off the electricity at the main fuse box or circuit breaker. Then, unplug appliances and let them dry out. Have appliances checked by a professional before using them again. Also, have the electrical system checked by an electrician before turning the power back on.

Water and sewage systems. If pipes are damaged, turn off the main water valve. Check with local authorities before using any water as it could be contaminated. Pump out wells and have the water tested by authorities before drinking. Do not flush toilets until you know that sewage lines are intact.

Food and other supplies. Throw out all food and other supplies that you suspect may have become contaminated or come in to contact with floodwater (see page 48).

Your basement. If your basement has flooded, pump it out gradually (about one third of the water per day) to avoid damage. The walls may collapse and the floor may buckle if the basement is pumped out while the surrounding ground is still waterlogged.

Cabinets. Open cabinets carefully and be alert for objects that may fall.

Clean up household chemical spills. Disinfect items that may have been contaminated by raw sewage, bacteria, or chemicals. Also clean salvageable items.

Call your insurance agent. Take pictures of damages. Keep good records of repair and cleaning costs including the hours you and your family and friends spend cleaning, etc.

Animals. Disaster and life threatening situations will exacerbate the unpredictable nature of wild animals. To protect yourself and your family, learn how to deal with wildlife.

- Do not approach or attempt to help an injured or stranded animal. Call your local animal control office or wildlife resource office.
- Do not corner wild animals or try to rescue them. Wild animals will feel threatened and may endanger themselves by dashing off into floodwaters, fire, and so forth.
- Do not approach wild animals that have taken refuge in your home. Wild animals such as raccoons often seek refuge from floodwaters on upper levels of homes and have been known to remain after water recedes. If you encounter animals in this situation, open a window or provide another escape route and the animal will likely leave on its own. Do not attempt to capture or handle the animal. Should the animal stay, call your local animal control office or wildlife resource office.
- Do not attempt to move a dead animal. Carcasses can present serious health risks. Contact your local government or health department for help and instructions.
- If bitten by an animal, seek immediate medical attention.





## Emotional Responses in Emergencies



### Typical First Reactions:

- Disbelief and shock
- Fear
- Problems with concentration or memory
- Need for help and information
- Disorientation & numbness
- Reluctance to abandon property
- Difficulty in making decisions
- Helpfulness to others

### Some Later Responses:

- Frustration and anxiety
- Moodiness and irritability
- Unexplained crying
- Change in appetite
- Difficulty sleeping or sleeping too much
- Feelings of powerlessness
- Guilt for survival or not preventing disaster
- Anger and suspicion
- Apathy and depression
- Fatigue, low energy
- Digestive problems
- Headaches, body pain
- Feeling overwhelmed
- Isolation from family and friends

### Special Effects on Children:

- Return to earlier behaviour such as thumb-sucking or bed wetting
- Reluctance to go to bed
- Fantasies that the disaster never happened
- Inability to concentrate
- Clinging to parents, crying or screaming
- Nightmares
- Refusal to attend school
- Withdrawal, immobility

### Special Effects on Pets:

- Unusually nervous or fearful
- Excessive protectiveness
- Sensitive to noise or storms
- Increased aggression

### Healing Emotionally

- Discuss what happened
- Recognize the losses you have suffered
- Give yourself and your family permission to grieve and time to heal
- You may want to limit exposure to media covering the event

## Helping Children Cope with Their Fears



### Before the Emergency

- Talk about your own experiences and/or read aloud about emergencies. Local libraries have some good books. Be sensitive to your children's needs as you do this. The point is not to frighten but to increase their awareness of some of the things that may happen.
- Walk through your house with them and have them practice quickly getting in each room's safe place. Hold frequent fire drills to reinforce this practice.
- Walk with your children around their favourite outside places to play. Identify the safe places to be in these locations.
- Ask your children's school about their emergency response plan. The school's plans may include holding the child until parents arrive. Make sure to explain this to your children and the reason why.
- Provide your children with the name of a relative or friend who will care for them if you should get stuck at work, etc. Preferably this will be a person that the children know and are comfortable with.

### After the Emergency

- Give lots of hugs to your children and tell them everything will be okay. This provides physical and verbal reassurance to them.
- Encourage your children to express their feelings, especially through play and physical activities. Listen to them carefully when they share these things with you.
- Be careful not to ignore the emotional needs of your children once you have determined that everyone is physically okay. Fear is a normal reaction to any dangerous situation.
- Include children in clean up activities. It is comforting to the child to watch the household begin to resume its normal functions. It also gives them a job to do.
- Children may revert to immature behaviour for a few days. Do not focus on this behaviour, rather praise them for their help in cleaning up, etc.
- Maintain routines but reduce performance expectations. If fears, sleep, or unusual behaviours get worse for more than two weeks, take the time to seek professional help.

## Helping Pets Cope with their Fears



### Before the Emergency

- Teach your pet to go into a carrier readily and experience it as a safe place (not just when they have to go to the vet or experience other scary things).
- If your pet can be transported in your vehicle, help them to get used to traveling early on (and not just to the vet or kennel) so that they look forward to rides.

### During the Emergency

- Speak to them in soft, reassuring voices.
- Whenever possible take your pets with you and pre-arrange places for them to stay.

### After the Emergency

Pets may not respond normally after an emergency/disaster. They may show fear, be in physical pain or display other “unfriendly” behaviours. Take the time to explain to your children that pets get hurt or afraid too and that because they can’t talk to us and tell us what is going on, they sometimes act differently and we need to take our time with them and not rush in to pat or hold them.

- Approach pets slowly and cautiously, watch for injuries or “unfriendly” behaviours.
- Avoid direct eye contact as you approach pets slowly and calmly.
- Speak to them in soft, reassuring voices. Don't forget they are survivors, too.
- Familiar routine always feels comforting. Provide food and fresh water on a regular schedule for caged or fostered animals.
- Time and patience are often the best medicines, but some pets will require the professional care of a board-certified veterinary behaviorist.

Remember, intense fear and anxiety should be considered forms of pain that deserve immediate treatment.

### Livestock

Livestock are an even greater challenge during emergencies so you need to do emergency planning for them well before the event. Work with your veterinarian and local farming groups to plan for mass evacuations of livestock (see page 14).

## Recovery Resources



### Recovery Begins with YOU!

1. What risks can you reduce before a disaster happens? See the sections on Emergency Preparedness at the beginning of this workbook.
2. Do you know how to take care of yourself and your family during a disaster? See the section on Responding Safely During Emergencies in the middle of this workbook.
3. Do you know what to do to start your recovery? Use this section and the information you get from community information provided during and after the disaster to help you get started on your recovery.

### Helping Each Other – Community Recovery

1. Work with your neighbours and community groups to start the clean-up process
2. If you can take someone or some family into your home temporarily, let your local government know as we may need lots of temporary housing assistance for those displaced during the disaster.
3. If you are a member of a service club, offer your group services to local government to assist with clean-up, food services, shelter or whatever services you can offer the community.

Recovery takes a lot longer than the original disaster so let's be patient. Recognize that this is an opportunity to improve and make our communities better and safer than before the disaster!

### Seeking Disaster Assistance

Throughout the recovery period, it is important to monitor local radio or television reports and other media sources for information about where to get emergency housing, food, first aid, clothing, and financial assistance. Your local governments and emergency program will be working to coordinate the recovery process during large events affecting the communities so check with them on what recovery resources may be available to you.

Although we appreciate the generosity of individuals and groups that wish to donate goods (food, clothing, toys, furniture, etc.) to those in disaster areas, these donations become a secondary disaster for those areas that now have to deal with truckloads of goods that need to be sorted and stored. Please note that the best gift is financial assistance and donations can be made to the Canadian Red Cross and sometimes even in the local community if a disaster fund has been established.



Another great resource is individuals that have been trained and are ready to assist at Emergency Services Reception Centres so please contact us at (807) 226 - 5241 to become a volunteer and receive the free training.



## Community Resources And Beyond

Community Resources to individuals and families may come from many organizations, including:



- Sioux Narrows - Nestor Falls Community Emergency Management will assist with family reunification and facilitate the provision of emergency food, clothing, lodging and emotional support to evacuees.



Canadian Red Cross  
Croix-Rouge canadienne



Giving Hope Today

125

- Canadian Red Cross provides family reunification and collects donations to assist with disaster relief
- Salvation Army provides disaster relief and emotional support services

## Disaster Financial Assistance

Ontario has a program to help those impacted by a disaster cope with the cost of repairs and recovery from disaster-related property damage if losses could not have been insured or where other programs are not available.

Those impacted by a disaster may apply to the Province of Ontario for Disaster Financial Assistance. Disaster Financial Assistance helps to replace or restore essential items and property destroyed or damaged by disasters, to pre-disaster condition.

Assistance is available to qualifying home owners, residential tenants, small businesses, farm operations, and not-for-profit charitable organizations.

# Personal Documents

(to fill out and photocopy)

Top 5 Recommendations:

1. Collect the information you will need to fill out the forms
2. Develop your rough draft separately and then write the final copy onto the pages in this workbook as a handy reference tool.
3. Photocopy these pages and ensure each family member has a copy.
4. Update the information as needed.
5. Keep this workbook easily accessible (by the main phone, on the coffee table)

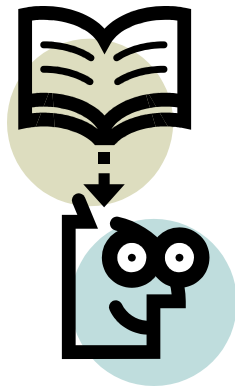

This section of the workbook will:

- ✓ Provide forms you can fill out and photocopy so that every family member has the important information to help you find each other after an emergency/disaster.
- ✓ Provide a grid that you can use to draw your home and all possible escape routes.
- ✓ Help you keep all emergency preparedness information in one book rather than on separate pieces of paper that may get lost. You may want to keep this workbook near the main phone for easy access.



## Emergency Information

Listen to local media such as: CBC Radio FM 95.7, CJRL MI X FM 89.5, CFOB FM 93.1, CKSX FM - 91.1 to get timely information updates during an emergency/disaster.

## Emergency Contact Person Card



- Choose a relative or friend who lives outside the disaster area, preferably with a different area code or in another province or country, who all family members can contact if it becomes impossible to reach your home or reunion sites. Communication within a disaster area is harder to establish than calling from a disaster area to an area not affected by the disaster. I deally choose someone who has voice mail or an answering machine so that you don't need to call repeatedly if they are not at home.
- Fill out the cards with this information for each family member to keep. (See page 3)
- Remind all family members to contact this person as soon as they can after the emergency and report how and where they are and their plans for the next few days Keep conversations short as the phone system will be overloaded with people trying to contact their loved ones.

EMERGENCY CONTACT PERSON:
Name: _____
Address: _____
Home Phone: _____
Work Phone: _____
Cell Phone: _____
Pager: _____

(see page 79 and 80 for cards to fill in, cut out and use)

## Important Individual & Family Information

Complete form, photocopy and ensure each family member carries it at all times. Update regularly!

Home Address: \_\_\_\_\_

Home Telephone: \_\_\_\_\_

1) Name: \_\_\_\_\_

Work/School Address: \_\_\_\_\_

Phone: \_\_\_\_\_

Medical #: \_\_\_\_\_

Medications / Allergies: \_\_\_\_\_

2) Name: \_\_\_\_\_

Work/School Address: \_\_\_\_\_

Phone: \_\_\_\_\_

Medical #: \_\_\_\_\_

Medications / Allergies: \_\_\_\_\_

3) Name: \_\_\_\_\_

Work/School Address: \_\_\_\_\_

Phone: \_\_\_\_\_

Medical #: \_\_\_\_\_

Medications / Allergies: \_\_\_\_\_

4) Name: \_\_\_\_\_

Work/School Address: \_\_\_\_\_

Phone: \_\_\_\_\_

Medical #: \_\_\_\_\_

Medications / Allergies: \_\_\_\_\_

Our Evacuation Plan:

a) Route: \_\_\_\_\_

b) Meeting Place: \_\_\_\_\_

Our Communication Plan:

a) Remember that pay telephones are treated as emergency telephones.

When you pick up the phone it may seem dead. Hold it and wait for the dial tone.

b) If our family members are in separate places when an emergency (storm, etc.) happens and are not able to get home we agree to leave messages with and contact each other through:

1) \_\_\_\_\_

(If #1 doesn't work out we will use #2)

2) \_\_\_\_\_

# Our Escape Route Plan

(use this grid to draw your home and how you can escape from each room safely)

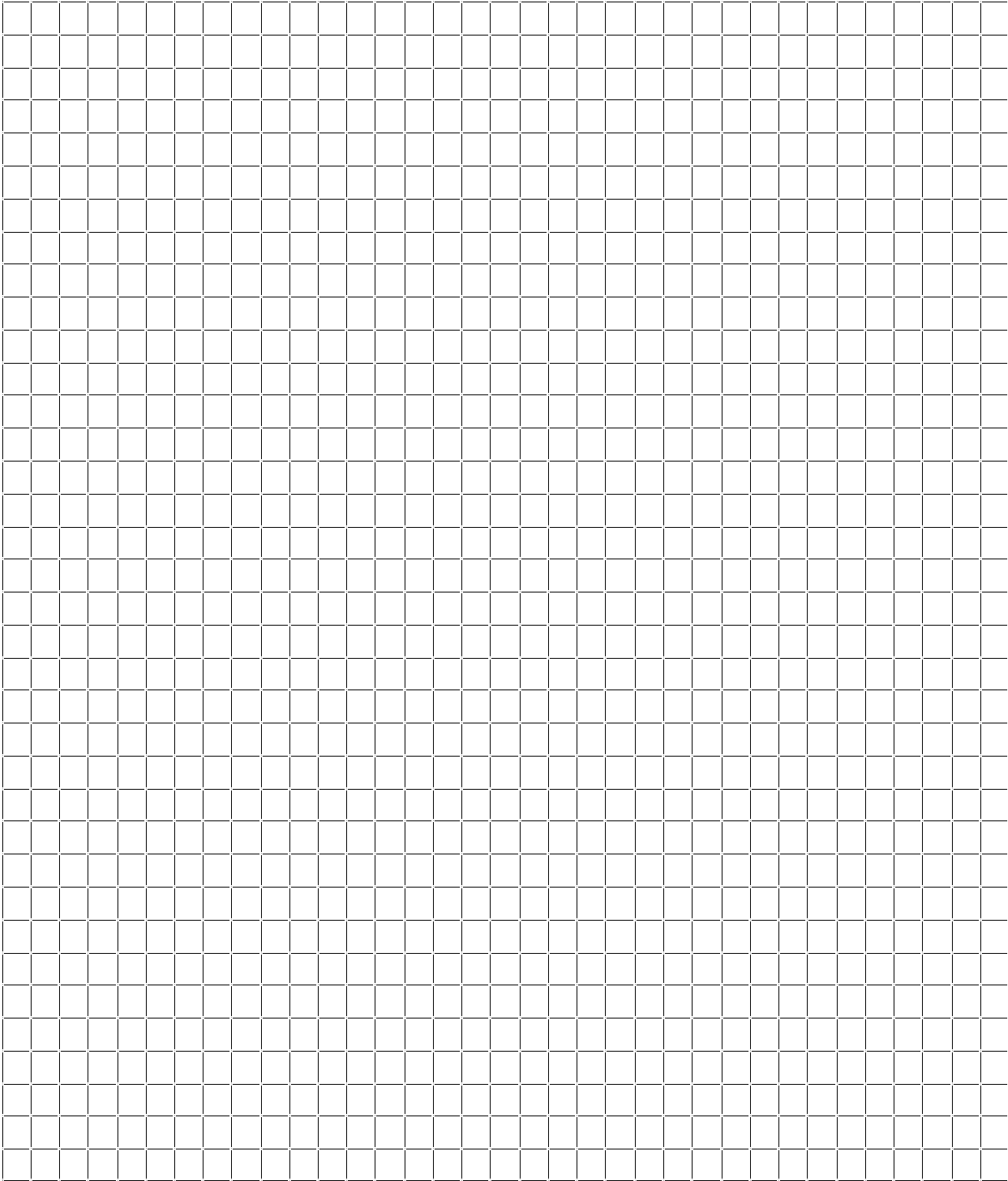

## Pets & Farm Animals - Important Telephone Numbers

1. Primary Veterinarian		7. Micro Chip Registry	
2. Alt. Veterinarian		8. Missing Pet Registry	
3. Animal Control		9. Out of Town Contact	
4. Boarding Kennel		10. Pet Sitter	
5. Emergency Clinic		11. Alt. Pet Sitter	
6. Humane Society		12. Poison Centre	

### Primary Veterinarian

Name:
Address:
Directions:
Hours:

### Alternate Veterinarian

Name:
Address:
Directions:
Hours:

## Sioux Narrows – Nestor Falls Emergency Reception Centres

### Sioux Narrows Community Hall

5685 HY 71, Sioux Narrows

### Nestor Falls Community Hall

11 MORTIMER RD, Nestor Falls

### Sioux Narrows Public School

5689 HY 71, Sioux Narrows

### Nestor Falls Public School

11 SCHOOL RD, Nestor Falls

### Sioux Narrows Curling Rink

31 RED INDIAN RD, Sioux Narrows

### Nestor Falls Curling Rink

21 MORTIMER RD, Nestor Falls

### Sioux Narrows Seniors' Centre

5655 HY 71, Sioux Narrows

Listen to local media such as: CBC Radio FM 95.7, CJRL MI X FM 89.5, CFOB FM 93.1, CKSX FM – 91.1 to get timely information updates during an emergency/disaster.

# Information Resources



## Top 5 Recommendations:

1. Listen to local stations including: CBC Radio FM 95.7, CJRL MI X FM 89.5, CFOB FM 93.1, CKSX FM – 91.1 to get timely information updates during an emergency/disaster.
2. Before adopting information that is contrary to this guide, check with your local emergency program to find out if this information is accurate.
3. Apply the Emergency Preparedness suggestions in this guide to help reduce the level of risk to your family and your home and may reduce the extent of your losses.
4. Share information with friends and family wherever they may be and encourage them to find out what Emergency Preparedness plans are in their community.
5. Get involved in helping your community prepare for and respond to emergencies (see pages 80 & 81 for ways to get involved).



## This section of the guide will:

- Provide additional Emergency Preparedness tips.
- Provide lists of additional information resources.
- Provide information regarding ways that you can volunteer and help your community.
- Provide Local Community Emergency Services information.
- Provide a Glossary of Emergency Preparedness terms.

## Emergency Information

Listen to local media such as: CBC Radio FM 95.7, CJRL MI X FM 89.5, CFOB FM 93.1, CKSX FM – 91.1 to get timely information updates during an emergency/disaster.





## Useful Information and Resource Links

Sioux Narrows – Nestor Falls Emergency Services

[www.siouxnarrows-nestorfalls.ca](http://www.siouxnarrows-nestorfalls.ca)

Provincial Emergency Program

[www.emergencymanagementontario.ca](http://www.emergencymanagementontario.ca)

Public Safety Canada (PS)

[www.ps-sp.gc.ca](http://www.ps-sp.gc.ca)

Canadian Red Cross

[www.redcross.ca](http://www.redcross.ca)

Emergency Preparedness for Industry and Commerce Council

[www.epicc.org](http://www.epicc.org)

Health Canada

[www.hc-sc.gc.ca](http://www.hc-sc.gc.ca)

Ministry of Transportation – Road Condition Reports

[www.mto.gov.on.ca/english/traveller](http://www.mto.gov.on.ca/english/traveller)

Ministry of Natural Resources – Current Fire Situation

[www.mnr.gov.on.ca/en/Business/AFFM/2ColumnSubPage/268862.html](http://www.mnr.gov.on.ca/en/Business/AFFM/2ColumnSubPage/268862.html)

Salvation Army

[www.salvationarmy.ca](http://www.salvationarmy.ca)

## Local Community Emergency Services

The following Emergency Services are available in your local community.

Interested in helping your community with emergency preparedness and response?  
Call the Township of Sioux Narrows – Nestor Falls 807-226-5241 to find out how.

### 9-1-1 Emergency Services

- This number allows you to contact a Dispatcher when you need immediate emergency assistance from Police, Ambulance or Fire Departments.
- These departments are dispatched separately, so the first question you need to answer is: "Police, Ambulance or Fire?"
- Once you get connected to the right dispatch centre you need to:
  - Give the address or location and phone number you are calling from
  - Speak clearly and describe the problem (i.e. there has been a car accident, someone is injured, there has been a break in, etc.)
  - Follow instructions from dispatch or emergency personnel
  - Stay with the injured person and give comfort
  - Ask bystanders to stay out of the way, clear the way for responders
- Never call 9-1-1 unnecessarily as you may be endangering someone else's life that is experiencing a true emergency.

### Emergency Preparedness Information Sessions

- Find out about local hazards and how you can protect yourself and your family.
- Find out how to be better prepared for emergencies no matter where you are when they occur (e.g. after a major earthquake most people will have to stay where they are as transportation routes may be impassable).
- Presentations are free and can be requested for your community, workplace, association, club, society or neighborhood group.

### Local Emergency Response Neighborhoods (LERN)

Take Emergency Preparedness to the next level by helping to organize your neighborhood. It's as simple as following these steps:

1. Talk to the neighbors closest to you (about 10 homes) and ask if they want to become prepared for emergencies.
2. Call 746-2500 to ask for a presentation – can be done in someone's yard or home.
3. Invite your neighbors to attend (flyers provided).
4. Come and find out how to prepare and get your questions answered.
5. Challenge each other to get prepared and share great ideas and finds.
6. Map important information about your neighborhood.
7. Sign up for the free training provided and continue developing your community spirit.

Remember - In an emergency or disaster, 80% of your help will come from your neighbors  
-learn how you can help each other effectively.

## Sioux Narrows – Nestor Falls Community Emergency Services

Sioux Narrows – Nestor Falls Community Emergency Services is a municipal/community-based emergency response program that provides services to preserve the well-being of people affected by an emergency or disaster – ranging from single house fires to calamities involving mass evacuations.

- The goal of the Program is to help people begin to re-establish themselves as quickly as possible after an incident ranging from single house fires to calamities involving mass evacuations.
- Emergency Services provides temporary relief to individuals and families so they can begin to plan their next steps after a disaster.
- Services may include providing accurate, up-to-date information, family reunification, emotional support and the coordination of food, clothing and lodging services.

## What to Expect When You Arrive at an Emergency Reception Centre

Please note it may take many hours to establish a Reception Centre after an incident. Once the Reception Centre is operational:

- Volunteers will meet with you, register you and your family and help assess your immediate needs.
- Registration helps us to reunite you with family and friends and ensure you receive important information updates regarding the emergency, so (even if you do not require assistance, please register).
- If you have pets, please plan now for who will take care of them in the event that you are evacuated as pets are not permitted in Reception Centres or in most hotels.
- Emergency Assistance is only available for a short time after the incident so it is imperative that you have a plan to look after your own family's needs.

## Amateur Radio Emergency Service (ARES)

Amateur Radio utilizes many different types of communication including: local voice radio conversations, voice and data conversations via satellite, and even by bouncing radio waves off the moon. In catastrophic events, once telephone service is lost the amateur or ham radio operators in the area are the only available method of communicating with the outside world. It's an exciting hobby with a world-wide fraternity with like-minded enthusiasts.

- During widespread emergencies or disasters, normal means of communication such as telephone service may be unavailable.
- We have a network of ARES Teams trained and ready to respond and provide emergency communications during such an event.

## Search and Rescue (SAR)

- Under the direction of the OPP, the Lake of the Woods Search and Rescue teams can be called out to search for and rescue individuals that have gone missing.
- They can also assist in evacuation notification.

## Information During an Emergency or Disaster

- Every effort will be made to provide prompt and accurate emergency information updates regarding the crisis, so please check local media or attend information sessions as they get posted.
- Information Resources include: CBC Radio FM 95.7, CJRL MI X FM 89.5, CFOB FM 93.1, CKSX FM - 91.1 to get timely information updates during an emergency/disaster.

## Emergency Preparedness Glossary

### Disaster:

A calamity that

(a) is caused by accident, fire, explosion or technical failure or by the forces of nature, and

(b) has resulted in serious harm to the health, safety or welfare of people, or in widespread damage to property.

### Emergency:

A present or imminent event or circumstance that

(a) is caused by accident, fire, explosion, technical failure or by the forces of nature, and

(b) requires prompt coordination of action or special regulation of persons or property to protect the health, safety or welfare of a person or to limit damage to property.

### Potable Water:

Potable water is water that is safe for humans and animals to drink without special precautions.



EMERGENCY CONTACT PERSON:  
Name: \_\_\_\_\_  
Address: \_\_\_\_\_  
Home Phone: \_\_\_\_\_  
Work Phone: \_\_\_\_\_  
Cell Phone: \_\_\_\_\_  
Pager: \_\_\_\_\_

EMERGENCY CONTACT PERSON:  
Name: \_\_\_\_\_  
Address: \_\_\_\_\_  
Home Phone: \_\_\_\_\_  
Work Phone: \_\_\_\_\_  
Cell Phone: \_\_\_\_\_  
Pager: \_\_\_\_\_

EMERGENCY CONTACT PERSON:  
Name: \_\_\_\_\_  
Address: \_\_\_\_\_  
Home Phone: \_\_\_\_\_  
Work Phone: \_\_\_\_\_  
Cell Phone: \_\_\_\_\_  
Pager: \_\_\_\_\_

EMERGENCY CONTACT PERSON:  
Name: \_\_\_\_\_  
Address: \_\_\_\_\_  
Home Phone: \_\_\_\_\_  
Work Phone: \_\_\_\_\_  
Cell Phone: \_\_\_\_\_  
Pager: \_\_\_\_\_

EMERGENCY CONTACT PERSON:  
Name: \_\_\_\_\_  
Address: \_\_\_\_\_  
Home Phone: \_\_\_\_\_  
Work Phone: \_\_\_\_\_  
Cell Phone: \_\_\_\_\_  
Pager: \_\_\_\_\_

EMERGENCY CONTACT PERSON:  
Name: \_\_\_\_\_  
Address: \_\_\_\_\_  
Home Phone: \_\_\_\_\_  
Work Phone: \_\_\_\_\_  
Cell Phone: \_\_\_\_\_  
Pager: \_\_\_\_\_

EMERGENCY CONTACT PERSON:  
Name: \_\_\_\_\_  
Address: \_\_\_\_\_  
Home Phone: \_\_\_\_\_  
Work Phone: \_\_\_\_\_  
Cell Phone: \_\_\_\_\_  
Pager: \_\_\_\_\_

EMERGENCY CONTACT PERSON:  
Name: \_\_\_\_\_  
Address: \_\_\_\_\_  
Home Phone: \_\_\_\_\_  
Work Phone: \_\_\_\_\_  
Cell Phone: \_\_\_\_\_  
Pager: \_\_\_\_\_

EMERGENCY CONTACT PERSON:  
Name: \_\_\_\_\_  
Address: \_\_\_\_\_  
Home Phone: \_\_\_\_\_  
Work Phone: \_\_\_\_\_  
Cell Phone: \_\_\_\_\_  
Pager: \_\_\_\_\_

EMERGENCY CONTACT PERSON:  
Name: \_\_\_\_\_  
Address: \_\_\_\_\_  
Home Phone: \_\_\_\_\_  
Work Phone: \_\_\_\_\_  
Cell Phone: \_\_\_\_\_  
Pager: \_\_\_\_\_

FAMILY REUNION SITES:  
Home:  
\_\_\_\_\_  
In Neighborhood:  
\_\_\_\_\_  
Outside Immediate Area:  
\_\_\_\_\_

FAMILY REUNION SITES:  
Home:  
\_\_\_\_\_  
In Neighborhood:  
\_\_\_\_\_  
Outside Immediate Area:  
\_\_\_\_\_

FAMILY REUNION SITES:  
Home:  
\_\_\_\_\_  
In Neighborhood:  
\_\_\_\_\_  
Outside Immediate Area:  
\_\_\_\_\_

FAMILY REUNION SITES:  
Home:  
\_\_\_\_\_  
In Neighborhood:  
\_\_\_\_\_  
Outside Immediate Area:  
\_\_\_\_\_

FAMILY REUNION SITES:  
Home:  
\_\_\_\_\_  
In Neighborhood:  
\_\_\_\_\_  
Outside Immediate Area:  
\_\_\_\_\_

FAMILY REUNION SITES:  
Home:  
\_\_\_\_\_  
In Neighborhood:  
\_\_\_\_\_  
Outside Immediate Area:  
\_\_\_\_\_

FAMILY REUNION SITES:  
Home:  
\_\_\_\_\_  
In Neighborhood:  
\_\_\_\_\_  
Outside Immediate Area:  
\_\_\_\_\_

FAMILY REUNION SITES:  
Home:  
\_\_\_\_\_  
In Neighborhood:  
\_\_\_\_\_  
Outside Immediate Area:  
\_\_\_\_\_

FAMILY REUNION SITES:  
Home:  
\_\_\_\_\_  
In Neighborhood:  
\_\_\_\_\_  
Outside Immediate Area:  
\_\_\_\_\_

FAMILY REUNION SITES:  
Home:  
\_\_\_\_\_  
In Neighborhood:  
\_\_\_\_\_  
Outside Immediate Area:  
\_\_\_\_\_



