

Model 2007 & 2017 User's Manual

**Nirvana Auto-Balanced
Photoreceivers**

Patent No. 5,134,276



Contents

| | | |
|-------------|--------------------------------------|-----------|
| I | Quick Start | 3 |
| II | Detector Operation | 5 |
| III | Principles Of Operation | 17 |
| IV | Operating With Optical Fiber | 20 |
| V | Applications Examples | 22 |
| VI | Troubleshooting | 30 |
| VII | Warranty, Service and Support | 32 |
| VIII | Specifications | 33 |

I

Quick Start

This section outlines the quickest path to using the Nirvana photoreceiver. For more detail on how to operate the Nirvana, see Section II, Detector Operation. For more information on using the Nirvana with fiber inputs, see Section IV, Operating With Optical Fiber.

1. Set up your optical experiment with a reference beam impinging on the *REF* photodiode and your signal beam impinging on the *SIGNAL* photodiode. Use an optical power between 0.1 mW and 1 mW to facilitate oscilloscope display of your results. **Make sure that your beamsplitter produces more power in the reference beam than in the signal beam (attenuate the signal beam if necessary).**
2. Apply ± 15 VDC power to Nirvana. See page 9 for more details on the power supply connectors.
3. Switch the *Linear Output* knob to the *SIG* mode. Turn the *Loop Bandwidth* knob to 100. For more detail on this function, see page 14.
4. Attach an oscilloscope to the *SIGNAL MONITOR* back panel BNC. Adjust the signal beam coupling, the oscilloscope display control, and your modulator input settings until the expected voltage waveform display appears on the oscilloscope. For instance, if your modulator is an optical chopper running at 1 kHz and 50% duty cycle, your output oscilloscope trace is expected to be a square wave at 1 kHz, 50% duty cycle, with an amplitude proportional to the received signal power.
5. Connect the oscilloscope to the back panel *LINEAR OUTPUT* BNC. The displayed voltage should again be the expected replica of your optical modulation. In the case of the chopper input, your displayed square wave should now show some enhanced edge response.

6. Block the signal beam with an opaque card. Switch the *Linear Output* knob to *BAL*. Adjust the reference beam coupling to maximize the *LINEAR OUTPUT* voltage.
7. Unblock both *REF* and *SIGNAL* beams and switch the *Linear Output* knob to *AutoBAL*.
8. If you are measuring a DC or low-frequency signal, monitor it on the *LOG OUTPUT*. If your signal is at high frequencies, monitor it on the *LINEAR OUTPUT*.

II Detector Operation

The New Focus Model 2007 and 2017 Nirvana photoreceivers eliminate many noise sources that can plague precision measurements. Nirvana's wide signal bandwidth and various outputs and settings give you the flexibility to design inexpensive shot-noise limited experiments with very little support electronics. Nirvana is designed for use in a dual-beam setup: one invariant reference path and one signal path which contains your experiment. Properly applied, Nirvana reduces common mode noise by over 50 dB at frequencies from DC to 125 kHz. Thus you can effectively eliminate laser-intensity noise and make shot-noise limited measurements at low frequencies without using lock-in amplifiers and optical choppers. Nirvana's patented circuitry subtracts the reference and signal photocurrents, canceling noise signals that are common to both channels. Unlike conventional balanced receivers, Nirvana's electronic gain compensation automatically results in balanced detection, even if the average optical intensities on the two detectors are different and time-varying. Nirvana's voltage outputs allow you to measure signal power with 50 dB less noise than in a single-beam experiment. In most cases, the noise floor will be determined by shot noise.

Nirvana is easy to use, but we recommend that you read this guide thoroughly before you try to set up and use the detector. Before using the photoreceiver in a fiber system, see Section IV, Operating With Optical Fiber.

Front Panel Controls

The Model 2007 and 2017 photoreceiver inputs consist of two photodiodes. One is designated the reference photodiode, labeled *REF*, while the other is designated the signal photodiode, and labeled *SIGNAL*. The outputs of the Nirvana photoreceiver are a set of user-selectable functions of the optical power applied to these photodiodes. When planning to use the detector in autobalanced mode, be sure that the reference photodiode receives more, and ideally twice as much, optical power as the signal photodiode.

Note: Since there are no windows on the photodiode, keep the photodiodes covered when not making measurements for extended periods of time.

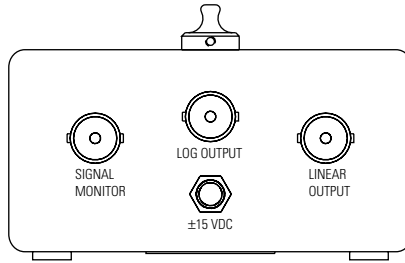

Nirvana Back Panel

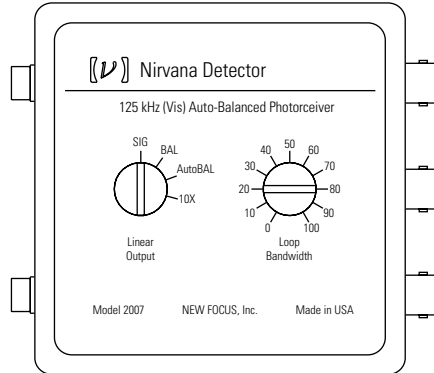

Nirvana TopPanel

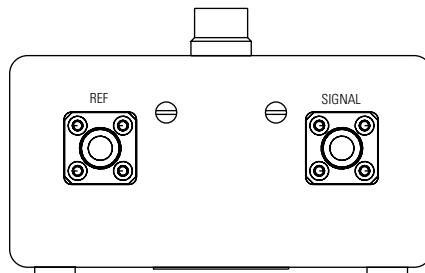

Nirvana Front Panel

| Knob Setting | Function |
|-----------------------|--|
| <i>SIG</i> | Signal monitor, voltage proportional to received <i>SIGNAL</i> optical power. |
| <i>BAL</i> | Traditional balanced detection, voltage proportional to difference between received <i>SIGNAL</i> and <i>REF</i> optical powers. |
| <i>AutoBAL</i> | Autobalanced detection, zero DC voltage, noise-suppressed AC signal proportional to received <i>SIGNAL</i> optical power. |
| <i>10X</i> | Autobalanced detection with higher gain. Same as <i>AutoBAL</i> setting, but with output voltage increased ten times. |

Table 1. Back-panel *LINEAR OUTPUT* BNC function as determined by the top-panel *Linear Output* knob position.

Top Panel Controls

The function of the Nirvana photoreceiver's outputs is controlled by a knob on the top panel. This Linear Output switch controls the operation of the back panel *LINEAR OUTPUT* as summarized in the previous table. With the *Linear Output* switch set to *SIG*, the *LINEAR OUTPUT* BNC provides a voltage proportional to the signal diode's photocurrent only. This function is useful for monitoring the signal power when setting up the experiment. With the *Linear Output* switch set to *BAL* the Nirvana functions as a traditional balanced detector. The *LINEAR OUTPUT* BNC provides a voltage proportional to the difference between the photocurrents of the signal and reference diodes. Use this mode when you want a traditional balanced receiver or to verify that the correct ratio of signal and reference optical powers has been achieved. With the *Linear Output* switch set to *AutoBAL* or *10X*, the Nirvana automatically balances the photocurrents from the signal and reference photodiodes at the subtraction node. Use these modes for optimum noise cancellation. In *10X* mode, the *LINEAR OUTPUT* BNC's voltage is ten times greater than in *AutoBAL* mode.

The *Loop Bandwidth* knob controls the cutoff frequency of the electronic gain compensation in auto-balanced operation. In most experiments, the optimal setting is 100. Nirvana's auto-balancing is the result of a low-frequency feedback loop that adjusts the gain of the *REF* photodiode to exactly balance the *SIGNAL* and *REF* photocurrents. In some cases, it may be advantageous to reduce the bandwidth of this feedback by reducing the *Loop Bandwidth* knob setting. For more details on this topic see page 14 and Section III, Principles of Operation.

Back Panel Controls

The back panel of the Nirvana photoreceiver contains the power input connector and three voltage output BNC's. Power for the Nirvana is enters through the microconnector power input, labeled ± 15 VDC.

The *SIGNAL MONITOR* BNC directly monitors the optical beam on the signal photodiode. This voltage output has a transimpedance gain of 10 V/mA for the signal photocurrent. This output is unaffected by the top panel controls or the *REF* photodiode optical input so it can be used to monitor the signal power. The output of the *LOG OUTPUT* BNC depends on the top panel *Linear Output* knob setting. When it is turned to either *AutoBAL* or *10X*, the *LOG OUTPUT* voltage is:

$$LOG\ OUTPUT \sim -1n\left(\frac{P_{REF}}{P_{SIGNAL}} - 1\right),$$

otherwise the output voltage is undefined. This output voltage provides a convenient measurement of absorption present in the signal path. It is bandwidth limited, with a bandwidth determined by the Top Panel *Loop Bandwidth* knob, and the *REF* and *SIGNAL* incident optical powers, as described in Section III, Principles Of Operation.

LINEAR OUTPUT is a voltage related to the *REF* and *SIGNAL* received optical powers as determined by the top panel *Linear Output* knob.

Making A Measurement

Mounting

Nirvana comes with a customer specified English or metric mounting pad. Insert the mounting pad into the bottom of the detector housing and secure with the three 4-40 screws provided. The mounting pad has a tapped 8-32 or M4 thread for convenient mounting to a pedestal or base.

Power Requirements and Cables

Two different power cables have been shipped with your detector: a New Focus Model 0921 banana plug-to-microconnector cable and a Model 0922 microconnector-to-microconnector cable. If you have a New Focus Model 0901 power supply, use the microconnector-to-microconnector cable on one of the supply's 0.3-A microconnector outputs to avoid reversing the power supply inputs. Use the banana plug cable with any power supply other than the 0901. Power supply requirements are a minimum of 0.1 A of current on $\pm 15\text{V}$. The color convention for the three banana plugs is:

| Banana Plug | Voltage | Current |
|-------------|---------|---------|
| Red | + 15 V | 0.1A |
| Green | COM/GND | N/A |
| Black | -15 V | 0.1 A |

Applying Optical Signals

After mounting the photoreceiver and applying power, direct the signal and reference beams onto the respective photodetectors. You can check the coupling efficiency of each signal by turning the *Linear Output* knob to *BAL* and monitoring the *LINEAR OUTPUT* BNC. Successively blocking each output

with a white card will allow you to optimize the coupling into each photodetector. When you have optimized the alignment, select your desired operating mode with the *Linear Output* knob.

Obtaining 50 dB Noise Suppression

To obtain the best possible noise suppression in autobalanced mode, you must carefully design your optical experiment. This section of the manual describes proper selection of parameters such as laser power, power split ratio, and modulation frequency. Further, it describes several optical component choices which may affect your perceived noise performance.

The optical setup can greatly affect the observed noise level in your measurement. Before beginning your experiment, measure the laser power, the signal modulation frequency (if any) and the power split ratio (the ratio of reference to signal power after the beamsplitter). Also measure (or control) the optical polarization of your beams, and losses in the signal and reference paths.

Laser Power

Figure 1 shows the common-mode rejection ratio (CMRR) vs. frequency for different photocurrents. The split ratio was fixed at nearly 2:1. Notice, the common-mode rejection improves with photocurrent. We recommend received photocurrents in the mA regime, but a low frequency CMRR of 50 dB can be obtained at microamp current levels. Improved high-frequency performance at the lower signal levels can be obtained through adjustment of the split ratio.

Figure 1

Common mode rejection ratio versus frequency.

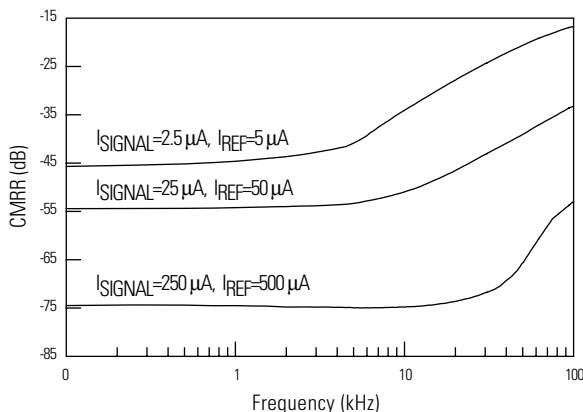

Modulation

Many experiments can be performed using Nirvana without laser beam modulation. Simply use the *LOG OUTPUT* as a measure of signal absorption directly. In many cases this output can be used in place of a chopper and lock-in amplifier. For more details on such an experiment see Section V, Applications Examples.

If your signal is inherently AC (not through signal beam modulation), or if you wish to take advantage of the narrow-band filtering property of synchronous detection, you must use the *LINEAR OUTPUT*. If you are using a modulated signal, the modulation frequency must be above the gain compensation cutoff frequency described on page 14 or else noise cancellation will be degraded.

If the signal beam is inherently modulated (e.g., a spectroscopic line in a lamp with a pulsed excitation source), noise present in the system is reduced dramatically in auto-balanced mode. Synchronous detection at f can serve to further reduce noise by accepting only a narrow bandwidth near f .

When using modulators for noise-reduction of DC detection experiments, place the modulator before the signal-reference beamsplitter. If your signal is inherently DC, you may think to modulate the signal beam at a frequency f_m by placing a modulator in the signal arm of your experiment. Don't do this. Because the reference channel (hence, the noise in the reference channel) is not modulated, the frequency shifted noise of the signal channel is no longer exactly replicated in the reference channel, and is therefore not canceled properly.

Loss in the Optical Paths

Differential, particularly time-varying, losses in the optical paths will be detected by Nirvana. If these losses are incidental to your experiment, they may mask your desired observations. Etalon and polarization sensitive effects in the two paths are common problems. Ideas on how to reduce these effects are presented later in this section of the manual.

Split Ratio

The split ratio affects the common-mode rejection achieved with Nirvana. In general, the power split ratio, P_{REF}/P_{SIGNAL} , should be close to 2. It is important to remember that it is the received signal power that is being measured. If the signal or reference arms have significant optical losses, then these factors must be taken into account when you set the split ratio. Figure 2 shows the common-mode rejection versus split ratio at a fixed signal power of 0.5 mW. You can see the common-mode rejection improve to better than 60 dB as the split ratio approaches 2.2:1. In general, you must determine the ideal split ratio empirically. Building your optical setup with the ability to adjust split ratio will ensure optimal results.

The ideal split ratio is also a weak function of optical power. Figure 3 shows, at a fixed frequency of 5 kHz, the ideal split ratio and corresponding common-mode rejection versus received signal power. As you reduce the signal power, the ideal split ratio tends towards 1, and the best common-mode rejection decreases. However, for received signal powers of greater than 0.5 mW, the ideal split ratio yields common-mode rejection exceeding 70 dB.

Figure 2

Common-mode rejection versus power-splitting ratio.

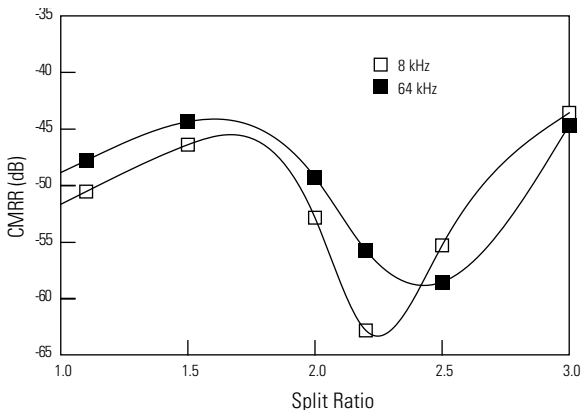
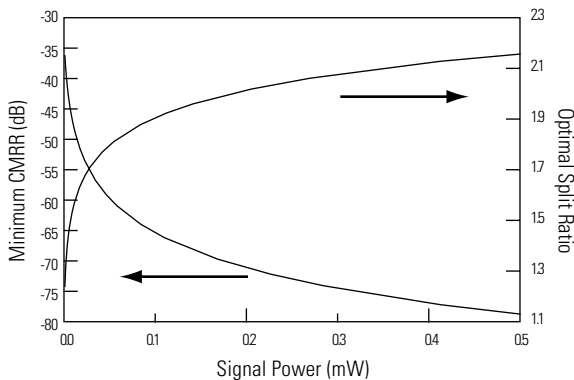

Figure 3

Minimum CMRR and optimal power-splitting ratio versus signal power.



Loop Bandwidth

The *Loop Bandwidth* knob controls the gain-compensation cutoff frequency, which determines the speed of the autobalancing effect. You must set the cut-off frequency as high as possible, but below any modulation frequency of

Figure 4

Gain compensation cutoff frequency is determined by Loop Bandwidth knob setting, signal photocurrent, and the power-splitting ratio.

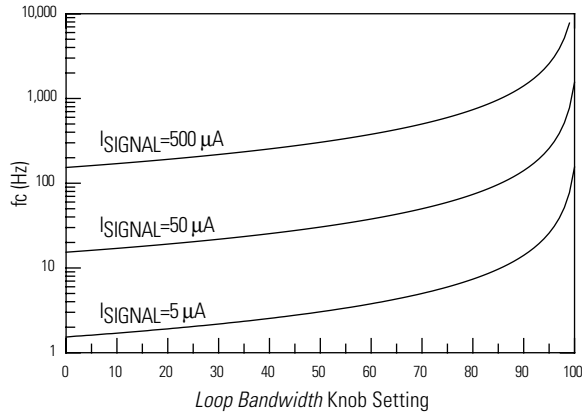

interest to obtain best noise cancellation and fastest response. The expression for the gain compensation cutoff frequency is given by:

$$f_c = 6 \times 10^4 \cdot \left(1 - \frac{P_{\text{SIGNAL}}}{P_{\text{REF}}} \right) \cdot P_{\text{SIGNAL}} \cdot R \cdot \frac{1}{(101 - LB)}$$

where P_{SIGNAL} and P_{REF} are the detected optical power in mW, R is the photodiode responsivity in A/W, and LB is the Loop Bandwidth knob setting. This relationship is graphed in Figure 4 with $I_{\text{SIGNAL}} = P_{\text{SIGNAL}} \cdot R$.

If you are using a modulated signal, the modulation frequency must be above the gain compensation cutoff frequency or else noise cancellation will be degraded. Because the gain compensation cutoff frequency has a single-pole, RC roll off, the modulation frequency should be significantly above the cutoff frequency so it does not effect noise cancellation performance. For example, a 10% modulation one decade above the cutoff frequency will have a 1% effect on the gain compensation circuit, thereby reducing noise cancellation performance.

Common reasons for lack of noise suppression

The Nirvana detector is a tremendously sensitive instrument for the measurement of differential optical signals. To the extent that you understand and control the source of the differential signal, Nirvana will serve you well. Unfortunately, your measurements will now be sensitive to effects which previously have been too small to be noticed. Remember, removing 50 dB of common mode noise will expose effects which were previously buried in noise. To be certain, we do not know all the effects which you will discover using Nirvana but we can warn you about a few which we have observed at New Focus.

Laser Polarization

Polarization noise in the source laser can create an unexpected differential signal due to different polarization sensitive optics in the signal and reference beam paths. This noise will not be canceled by Nirvana because it appears as differential amplitude modulation on the detected light rather than a common mode modulation. For this problem, it is good practice to begin your optical setup with a polarizer.

Frequency Modulation

Current modulation of diode-laser drive current is notorious for creating frequency modulation in addition to the desired amplitude modulation. Many optical elements and coatings act as étalons, converting this frequency modulation into an amplitude modulation. Because the reference and signal path optics are different, the unexpected FM results in a differential signal. A beam-splitter is a likely culprit for étalon effects and we recommend using either a plate or a Wollaston prism type beamsplitter, where stray beams are reflected away from the photodiodes.

Spatial Modulation

Modulation techniques and experiments can impart angular deviation or

spatially varying intensities in the laser beam. Non-uniformities in the photodetectors or vignetting can map this spatial variation into differential amplitude modulation. Focusing your beams onto the detectors can help. It is a good idea to use a single lens before splitting your reference beam from your signal beam if it is possible, and folding mirrors to focus both beams onto their detector. Liberal usage of apertures and irises to prevent stray reflections will also be useful.

Polarization Wiggle

Several modulation techniques, most notably acousto-optic modulation, create small rotations in the polarization of the modulated light. If the optics following the acousto-optic modulator are polarization sensitive, the polarization rotation becomes an unexpected amplitude modulation. To remove these problems, follow an acousto-optic modulator with a polarizer and expect a bit of extra amplitude modulation.

Figure 5

Nirvana's noise cancellation capability (common-mode rejection).

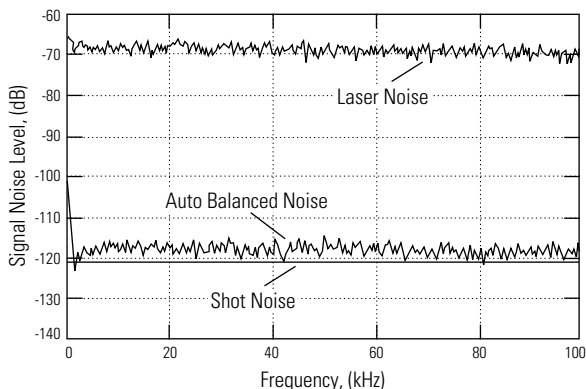

III Principles Of Operation

This section provides further detail on the operating modes and outputs of the Nirvana photoreceiver.

Figure 5 shows the type of noise-cancellation performance you can expect to obtain using Nirvana. We refer to the difference between the common-mode signal curve and the autobalanced curve as common-mode rejection ratio (CMRR) which is computed as,

$$CMRR = 20 \log_{10} \left(\frac{V_{COMMON-MODE}}{V_{AutoBAL}} \right),$$

where $V_{COMMON-MODE}$ is the detector output voltage proportional to $P_{COMMON-MODE}$ (the laser power present on the reference and signal photodiodes at the frequency of interest), $V_{AutoBAL}$ is Nirvana's output voltage at the same frequency in auto-balanced mode. The common-mode rejection ratio is a limit on Nirvana's ability to remove experimental noise.

The three BNC output connectors on Nirvana's back panel provide distinct measurements of the input optical power. The *LINEAR OUTPUT* voltage is

Generated Voltage on Nirvana's 3 BNC Connectors

| | SIGNAL MONITOR | LOG OUTPUT | LINEAR OUTPUT |
|--|---------------------------|--------------------------------|--|
| Linear Output Mode Switch Setting | SIG | $-10 \cdot R \cdot P_{SIGNAL}$ | Undefined voltage $20 \cdot R \cdot P_{SIGNAL}$ at DC, $100 \cdot R \cdot P_{SIGNAL}$ $f > 50$ Hz |
| | BAL | $-10 \cdot R \cdot P_{SIGNAL}$ | Undefined voltage $20 \cdot R \cdot [P_{SIGNAL} - P_{REF}]$ at DC, $100 \cdot R \cdot [P_{SIGNAL} - P_{REF}]$ $f > 50$ Hz |
| | Auto- BAL | $-10 \cdot R \cdot P_{SIGNAL}$ | $-\frac{T}{273} \ln\left(\frac{1}{g} - 1\right)$ DC to f_c $20 \cdot R \cdot [P_{SIGNAL} - g \cdot P_{REF}] = 0$ at DC, $100 \cdot R \cdot [P_{SIGNAL}(f) - g \cdot P_{REF}(f)]$ $f > f_c$ |
| | 10X | $-10 \cdot R \cdot P_{SIGNAL}$ | $-\frac{T}{273} \ln\left(\frac{1}{g} - 1\right)$ DC to f_c $20 \cdot R \cdot [P_{SIGNAL} - g \cdot P_{REF}] = 0$ at DC, $1000 \cdot R \cdot [P_{SIGNAL}(f) - g \cdot P_{REF}(f)]$ $f > f_c$ |

Table 2. Mathematical formulas for Nirvana's voltage outputs.

further determined by the *Linear Output* switch setting, as described in general terms in Table 1. Table 2 provides the mathematical expressions for each of the outputs.

In Table 2, P_{SIGNAL} and P_{REF} are the received optical powers in mW, R is the photodiode responsivity in A/W, T is the absolute temperature of Nirvana circuit in degrees K, g is the internally adjusted reference channel gain $P_{\text{SIGNAL}}/P_{\text{REF}}$, f is the frequency of interest and f_c is the cutoff frequency of the automatic gain compensation circuit.

A simplified schematic of the Nirvana is shown on page 36. Nirvana's electronics uses a single transimpedance amplifier to generate a voltage related to the input optical power on the two detectors (the relationship depends on the switch settings). The voltage is integrated in a low-frequency feedback loop as an error signal for the autobalance circuitry. The voltage output amplifier uses both DC and AC paths to provide higher gain to AC signals while maintaining the ability to monitor DC levels.

What is the significance of the Loop Bandwidth?

The internal gain g is automatically adjusted by Nirvana's circuitry to bring the low frequency portion of the linear output to zero. The cutoff frequency of the gain compensation circuit is determined by several parameters: the top panel *Loop Bandwidth* knob setting, the received signal power, and the reference power. Keep in mind that common mode noise is canceled all the way up to Nirvana's 125 kHz bandwidth limit. The gain-compensation cutoff frequency is more aptly thought of as the inverse of the time required for the gain compensation circuitry to adjust to changes in *REF* or *SIGNAL* power.

The gain-compensation cutoff frequency relationship to *Loop Bandwidth* knob setting and photocurrent is shown in Figure 6. Figure 6 was generated with an assumed power split ratio of $P_{\text{REF}}/P_{\text{SIGNAL}}=2$. The cutoff frequency axis scales with received signal photocurrent according to:

Figure 6

Gain compensation cutoff frequency, f_c , versus Loop Bandwidth knob setting.

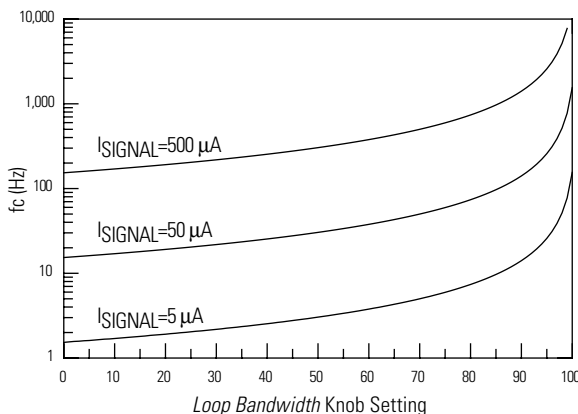

$$f_c \propto 2 \cdot \left(1 - \frac{P_{\text{SIGNAL}}}{P_{\text{REF}}} \right).$$

Thus, the cutoff frequency can increase to twice the value shown in Figure 6 for the case of reference power much greater than signal power. Remember that in your experiments modulation frequencies should be maintained above the cutoff frequency, and that DC time-resolved measurements using the *LOG OUTPUT* are limited to frequencies below the cutoff frequency.

The *LOG OUTPUT* is bandwidth limited up to the selected gain-compensation cutoff frequency. Common mode noise within this bandwidth is canceled in the *LOG OUTPUT*. The gain-compensation cutoff frequency ultimately determines the maximum rate of change of the *LOG OUTPUT*, and thus forms a limitation on the temporal resolution of the measurement of a dynamic system.

The gain compensation circuit requires balancing of the average values of the signal and reference photocurrents at the subtraction node. In the event of modulation frequencies (signal modulation) chosen below the gain-compensation cutoff frequency, the modulation will result in adjustment of the value of g , with the net effect of creating imbalance between the reference and signal at the modulation frequency. Noise cancellation will be adversely affected.

IV Operating with Optical Fiber

Installation

The Model 20X7 Nirvana photoreceiver comes with two precision machined alignment ferrules for use in fiber-based experiments. The alignment ferrules are held in the front panel by two phillip-head machine screws.

To install the fiber alignment ferrules for operating Nirvana with optical fiber, first removes the two fiber ferrules attached to the front panel by 2-56 Phillips screws. Then insert the two ferrules under the FC connector housings as shown below. Finally, reattach the alignment ferrules with the original screws.

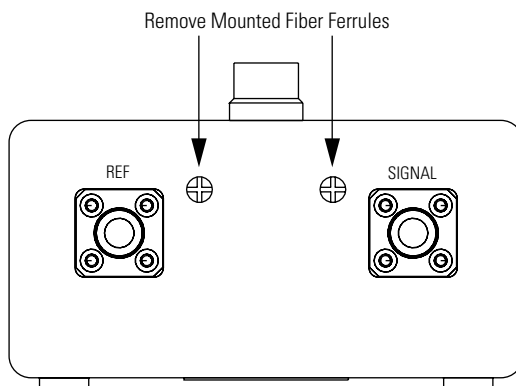

Locating the fiber ferrules.

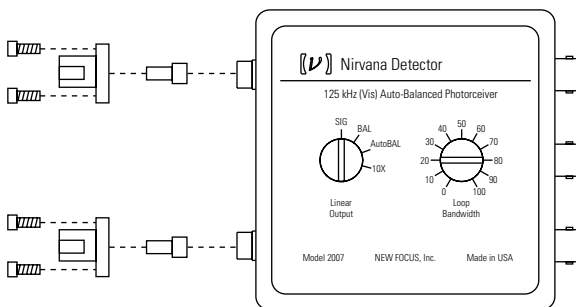

Inserting the fiber ferrules.

Optimizing Performance

Using optical fiber coupling to Nirvana will most likely reduce noise suppression by at least 10 dB. Differential losses in the *SIGNAL* and *REF* optical paths that fluctuate at frequencies higher than the gain compensation cutoff frequency (f_c) will be passed along to the output directly as perceived signal fluctuations. If such differential signals are at frequencies below f_c , they will degrade the noise suppression performance. Reducing sources of differential loss between the two channels will improve your experiment. We make the following recommendations.

Use angle-polished fiber. Étalon effects result in differing amounts of loss as a function of wavelength. Because wavelength is often fluctuating in an experiment (for instance, a current-modulated laser diode shows wavelength modulation), étalon effects must be avoided. Using angle-polished optical fiber will greatly reduce étalon effects in the fiber.

Use multimode fiber. When the fiber core diameter is increased, coupling efficiency and insensitivity to misalignment are improved. Because optical beams often have spatial modulation (for instance, an acousto-optically modulated beam typically has some spatial modulation), coupling can cause a differential loss between the signal and reference channels. We recommend using multimode, large core diameter fiber for best performance.

V Applications Examples

We recommend the following experiment to help you learn how to use Nirvana. This experiment will familiarize you with Nirvana's features and techniques for their successful use. In this experiment, you will intentionally create a common-mode signal and demonstrate Nirvana's ability to cancel it. Begin by setting up the experiment of Figure 7. This setup resembles that which you will use if you desire modulation and synchronous detection as a noise-reduction technique. For most applications, Nirvana's inherent noise reducing capabilities will eliminate the need for modulation when the signal of interest is inherently low-frequency.

Figure 7

Experimental setup to demonstrate the cancellation of a large common-mode signal.

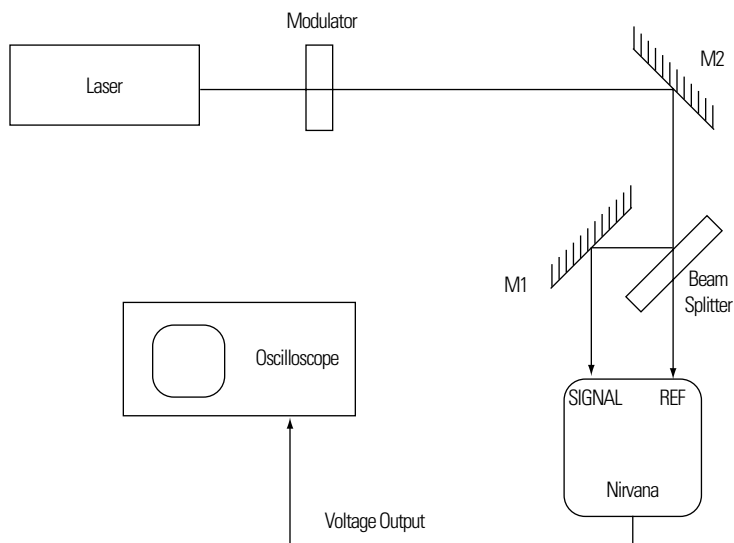

Demonstration Experiment

1. Set up the optical experiment of Figure 7. In the light-modulator signal source location, you can use any convenient optical modulator which operates in the frequency range from 1 kHz to 125 kHz. For the light source, use any laser in the operating range of your Nirvana (400-1070 nm for Model 2007, 800-1700 nm for Model 2017). Use an optical power between 0.1 mW and 1 mW to facilitate oscilloscope display of your results. **Make sure that your beamsplitter produces more power in the reference beam than in the signal beam (attenuate the signal beam if necessary).**
2. Apply ± 15 VDC power to Nirvana.
3. Switch the *Linear Output* knob to the *SIG* mode.
4. Turn the *Loop Bandwidth* knob to 100. This selects maximum common-mode rejection and minimum output settling time. Unless you are using high optical power or low frequency modulation of your signal, you will do best to leave the knob set to 100. The relationship between the *Loop Bandwidth* setting and common-mode rejection and output settling time depends on the optical incident power, as described in greater detail on page 13.
5. Attach an oscilloscope to the *SIGNAL MONITOR* back panel BNC. The *SIGNAL MONITOR* output is independent of the *Linear Output* knob setting and has a voltage output of $10 \cdot R \cdot P_{\text{SIGNAL}}$ where P_{SIGNAL} is the received optical power (in mW) at the signal photodiode and R is the photodiode's responsivity (A/W) at the laser wavelength.
6. Adjust M1, the oscilloscope display control, and your modulator input settings until the expected voltage waveform display appears on the oscilloscope. For instance, if your modulator is an optical chopper running at 1 kHz and 50% duty cycle, your output oscilloscope trace is expected to be a square wave at 1 kHz, 50% duty cycle, with an amplitude proportional the received signal power.

7. Connect the oscilloscope to the back panel *LINEAR OUTPUT* BNC of Nirvana. The displayed voltage should again be the expected replica of your optical modulation. The output voltage is now $20 \cdot R \cdot P_{\text{SIGNAL}}$ for low signal frequencies and $100 \cdot R \cdot P_{\text{SIGNAL}}$ for high signal frequencies (the corner frequency is around 50 Hz). In the case of the chopper input, your displayed square wave should now show some enhanced edge response.
8. Temporarily block the reference beam with an opaque card.
9. Switch the *Linear Output* knob to *BAL*. Your oscilloscope waveform should remain unchanged, because in balanced mode, Nirvana's *LINEAR OUTPUT* is simply the difference in the detected optical powers on the signal and reference photodiodes. Since the reference beam is blocked, this output is just the signal. Record the displayed voltage for comparison in the next step.
10. Temporarily block your signal beam with an opaque card. Leaving the *Linear Output* knob in the *BAL* position, you should now expect to see the reference signal on your oscilloscope.
11. Adjust M2 for alignment until the reference trace is displayed on the oscilloscope. Record the displayed voltage for comparison in the next step. Block the REF beam and adjust M1 to realign the signal beam onto the signal photodetector.
12. If the signal voltage exceeds the reference voltage, insert attenuation in the signal path or otherwise adjust the power split ratio ($P_{\text{REF}}/P_{\text{SIGNAL}}$) and return to Step 9.
13. Unblock both reference and signal beams. Observe that your displayed voltage is now the difference between the reference and signal voltages which you previously recorded.
14. Next test the auto-balanced mode of operation. Switch the *Linear Output* knob to *AutoBAL*. Your displayed voltage waveform drops nearly to zero. Nirvana has adjusted the gain in the reference detector so that its internal

reference and signal currents are equal. The effect is that the *LINEAR OUTPUT* voltage is now $P_{SIGNAL} - g \cdot P_{REF}$ where g is adjusted by Nirvana's internal feedback circuit to force the output to zero. The *AutoBAL* mode has effectively canceled the common-mode input modulation which was present.

15. Switch the *Linear Output* knob to *10X*. Your displayed voltage waveform should increase.
16. The residual unconcealed signal you have been observing in steps 14 and 15 is a combination of several effects: Nirvana's circuit and detector noise (which is quite small), your oscilloscope's input noise (somewhat larger), interference pickup in your cable (comparable to the scope's input noise), and most importantly, unintended differential signal created in your optical setup. The magnitude and nature of this unintended differential signal depends on your choice of modulator and your optics. Common problems observed with various configurations are discussed on page 15.
17. Connect the oscilloscope to the *LOG OUTPUT* BNC connector. The display is now a DC voltage whose magnitude is related to the ratio of the received reference power and signal power by

$$LOG OUTPUT \sim -1n\left(\frac{P_{REF}}{P_{SIGNAL}} - 1\right)$$

If attenuation is readily available, reduce P_{SIGNAL} to verify the *LOG OUTPUT* relationship.

Fast Scan Spectroscopy Using Nirvana's *LOG OUTPUT*

The Experiment of Figure 8 has been performed using Nirvana as a demonstration of the utility of the *LOG OUTPUT*, which provides time-varying absorption information as a time-varying (low frequency bandwidth limited) voltage. The source, a New Focus External-Cavity Tunable Diode Laser, is scanned through a range of wavelengths to determine the absorption spectrum of a sample. A noise modulator was added for demonstration purposes.

Figure 9 (trace a) shows the output of the experiment in the *SIG* output mode, typical of how a user without a balanced detector would observe the

Figure 8

Using the Nirvana photoreceiver to measure low-frequency absorption signals. Nirvana's LOG OUTPUT is observed directly; no modulation or synchronous detection is required.

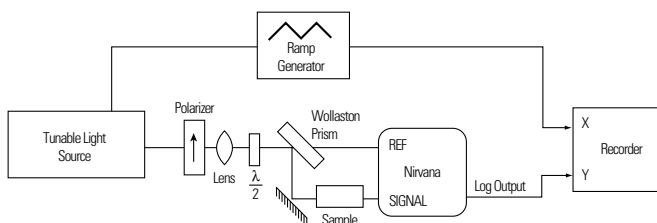

result. Notice that variations in laser power with wavelength, coupled with laser and detector noise sources yield results which are difficult to interpret. When the output mode is switched to *AutoBAL*, much of the noise is simply canceled, as shown in Figure 9 (trace b).

The scan frequency must be lower than the cutoff frequency of the *LOG OUTPUT*. Accordingly, the Loop Bandwidth knob should be adjusted to

Figure 9

Absorption measurement of a Rubidium line. The displayed voltage is proportional to the exponential absorption coefficient (see Table 2).

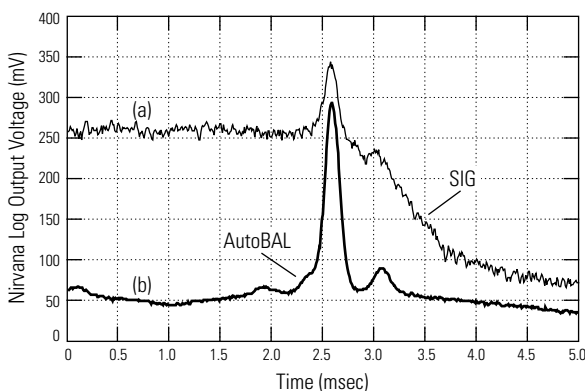

the 100 setting for widest possible *LOG OUTPUT* bandwidth. If the observed experimental signal-to-noise ratio is not adequate for your purposes, improvements can be made through adjustment of laser input power, reference to signal splitting ratio, and scan frequency, as described in Section III, Principles Of Operation.

Wavelength Modulation Spectroscopy Using Phase

Sensitive Detection

The noise-reduction capabilities of Nirvana in many instances obviate the need for high-frequency optical modulation and phase sensitive detection. However, even further noise reductions may be obtained using these techniques. Because Nirvana provides you with a virtually noise-free light source even at low frequencies, high frequency modulation is of no advantage (high frequency modulation is typically useful in placing an experiment's frequency of interest above the typical spectrum of laser noise).

Figure 10

Using the Nirvana photoreceiver for synchronous detection of an amplitude modulated signal.

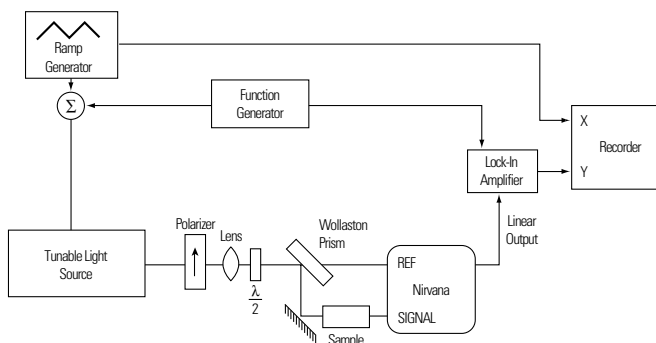
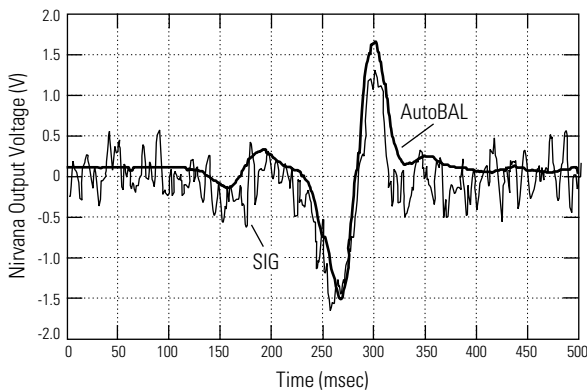

Figure 11

Using a wavelength-modulated source, the display voltage is proportional to the derivative of the power absorption. This result is the derivative of the curve in Figure 9.



In the experiment of Figure 10, the laser is wavelength modulated at 5 kHz on both the signal and reference optical paths. The noise was added for demonstration purposes only. The absorption in the experiment converts the wavelength modulation into an amplitude modulation, which is now a differential signal between signal and reference channels. The lock-in amplifier performs phase-sensitive detection at 5 kHz, converting the (AC coupled, 5 kHz)

LINEAR OUTPUT voltage of Nirvana into a DC level proportional to the transmission of the signal beam through the experiment (which is proportional to the derivative of the absorption vs. wavelength curve). Because Nirvana has reduced laser source noise at 5 kHz by over 50 dB (limited in most practice by the reference and signal channel shot noise), the lock-in amplifier output is stable even at short integration times. Oscilloscope traces showing lock-in amplifier output vs. scanned wavelength (a 1 Hz linear scan) are shown in Figure 11 for the *SIG* and *AutoBAL* switch settings.

VI Troubleshooting

If you are not obtaining the expected outputs from your Nirvana detector, you can check for several common sources of error. The following checklist should help you to diagnose difficulties you may have. If you reach a point in this list where you believe your detector to be faulty see Section VII, Warranty, Service and Support.

1. Verify that you have power applied to the detector.
2. Verify that your optical signal is being received by Nirvana by observing the *SIGNAL MONITOR* voltage.
3. Verify that your linear output is active by observing the *LINEAR OUTPUT* voltage with your optical signal applied to the signal photodiode and the *LINEAR OUTPUT* selection knob in the *SIG* position.
4. Verify that the *BAL* detection mode is functional by observing the *LINEAR OUTPUT* voltage with both (a) your optical signal applied to the signal photodiode, the reference optical signal blocked, and the *LINEAR OUTPUT* selection knob in the *BAL* position, and (b) your reference optical signal applied to the *REF* photodiode, and the *SIGNAL* optical signal blocked.
5. While still in the balanced detection mode, repeat the previous step and determine the DC ratio of *REF* and *SIGNAL* optical powers. Optimal performance is obtained for power split ratio near 2.
6. If either of the measured *LINEAR OUTPUT* voltages in the previous step exceeds 10 V, reduce the optical power in your experiment, you are probably saturating the photodiodes.

7. Check Figure 4, page 14, to ensure that your *Loop Bandwidth* knob position corresponds to a *Loop Bandwidth* selection lower than your modulation frequency.
8. In *AutoBAL* mode, verify that the *LOG OUTPUT* is $-\ln(P_{\text{ref}}/P_{\text{sig}} - 1)$ for P_{REF} and P_{SIGNAL} as measured previously. If this output exceeds ± 10 V, adjust your power split ratio to bring Nirvana's internal feedback loop back out of saturation.
9. If the Nirvana outputs are functional as verified by tests above, and your optical power, split ratio and modulation frequency meet the descriptions above, you have probably reached this point because you see 'noise' in your measurement which exceeds your expectations. The chances are good that this 'noise' is a result of differential signal modulation introduced by your source or optics, see page 15 for a discussion of unintended differential modulation sources.

VII Warranty, Service and Support

Your model 20X7 Nirvana photoreceiver has been designed to provide years of trouble-free operation. Any questions regarding the operation or performance of the Nirvana will be gladly answered by New Focus engineers.

Warranty

New Focus, Inc. guarantees its products to be free of defects for one year from the date of shipment. This is in lieu of all other guarantees, expressed or implied, and does not cover incidental or consequential loss.

Care And Storage

We have removed the windows from the Nirvana photodetectors to avoid étalon effects when scanning laser frequencies. Be sure to cover the photodetectors when not making measurements for extended periods (e.g., overnight) in order to minimize their exposure to dust and dirt.

Service

Virtually no maintenance is required except for ensuring that the photodetectors are not contaminated and unit is not damaged, or used in an unsafe manner. To ensure that the photodetectors are kept clean, cover them with the caps provided. If you suspect that the photodiodes have become dirty, try blowing the dirt out with a gentle stream of an inert gas such as Chemtronics® Ultrajet® 2000.

For service or repair please call for a return authorization number before shipping the unit to New Focus. You can reach us at:

New Focus, Inc.

2630 Walsh Avenue
Santa Clara, CA 95051-0905 USA

Phone: (408) 980-8088

Fax: (408) 980-8883

Email: Contact@NewFocus.com

VIII Specifications

Mechanical

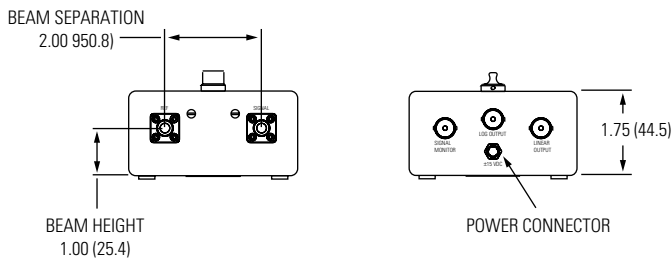
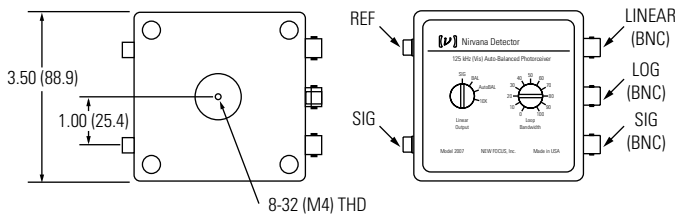

Typical Photodiode Responsivity

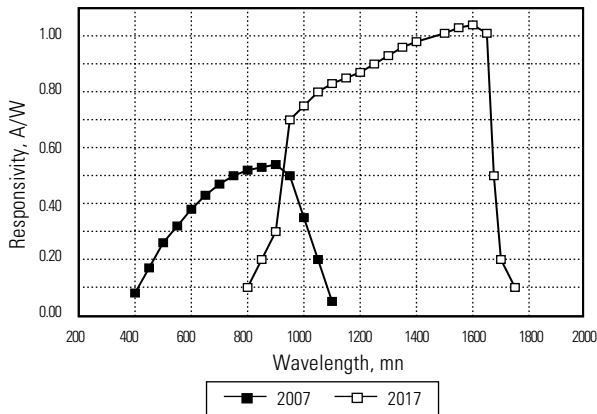

Performance

| Model # | 2007 | 2017 |
|-----------------------------|------------------------------|------------------------------|
| Wavelength Range | 400–1070 nm | 800–1700 nm |
| Common Mode Rejection | 50 dB | 50 dB |
| 3-dB Bandwidth | 125 kHz | 125 kHz |
| Detector Mat./Type | Silicon PIN | InGaAs PIN |
| Detector Diameter | 2.5 mm | 1 mm |
| Max. AC Conversion Gain | 5.2×10^5 V/W | 1×10^6 V/W |
| Max. Responsivity | 0.52 A/W | 1 A/W |
| Transimpedance Gain | 1×10^6 V/A | 1×10^6 V/A |
| Output Impedance | 100 Ω | 100 Ω |
| Min. Noise Equivalent Power | < 3 pW/ $\sqrt{\text{Hz}}$ | < 3 pW/ $\sqrt{\text{Hz}}$ |
| cw Saturation Power | 1 mW | 0.5 mW |
| Max. Pulse Power | 10 mW | 10 mW |
| Power Requirements | ± 15 V DC, < 300 mA | ± 15 V DC, < 300 mA |
| Optical Input | FC & Free Space | FC & Free Space |

Schematic of Nirvana

