

**OWNER'S OPERATING AND MAINTENANCE MANUAL
MANUEL DE L'UTILISATEUR ENTRETIEN ET
FONCTIONNEMENT
MANUAL DE INSTRUCCIONES Y MANTENIMIENTO**

**STAND UP LIFT - MODEL RPS350-1
LÈVE-PATIENT - MODÈLE RPS350-1
LEVANTADOR - MODELO RPS350-1**

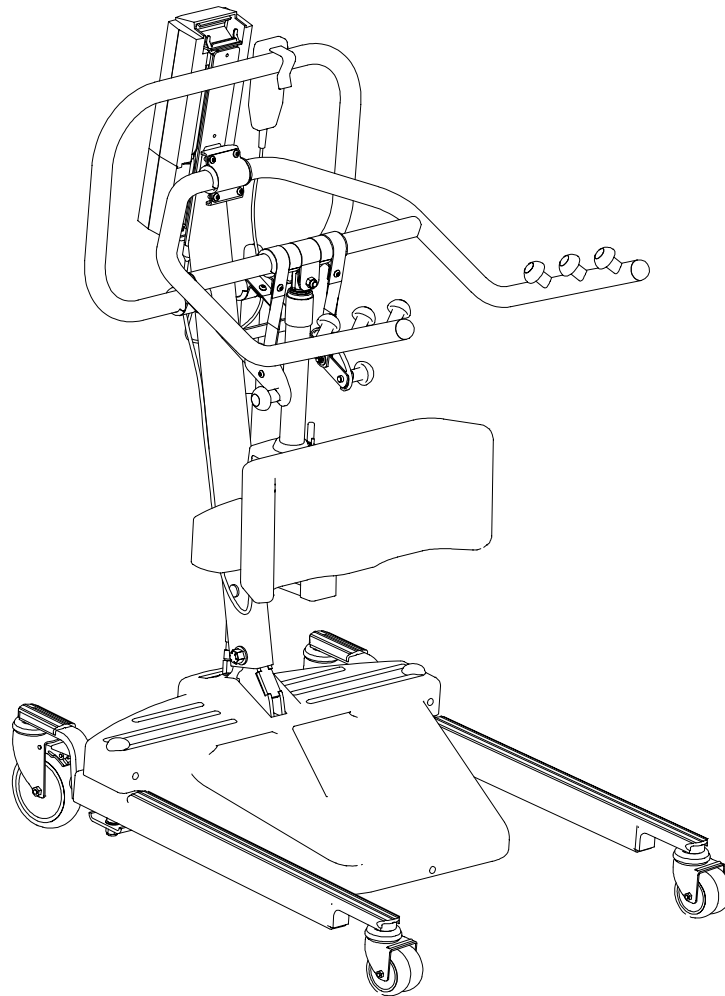

DEALER: THIS MANUAL MUST BE GIVEN TO THE USER OF THE PATIENT LIFT.

USER: BEFORE USING THIS PATIENT LIFT, READ THIS MANUAL AND SAVE FOR FUTURE REFERENCE.



Yes, you can.

SPECIAL NOTES

WARNING

DO NOT OPERATE THIS EQUIPMENT WITHOUT FIRST READING AND UNDERSTANDING THE WARNINGS, CAUTIONS AND INSTRUCTIONS IN THIS MANUAL AND THE OWNER'S MANUAL PROVIDED WITH THE SLINGS. IF YOU ARE UNABLE TO UNDERSTAND THE WARNINGS, CAUTIONS, AND INSTRUCTIONS, CONTACT A HEALTHCARE PROFESSIONAL, DEALER OR TECHNICAL PERSONNEL IF APPLICABLE BEFORE ATTEMPTING TO USE THIS EQUIPMENT - OTHERWISE INJURY OR DAMAGE MAY RESULT.

RADIO FREQUENCY INTERFERENCE

Most electronic equipment is influenced by Radio Frequency Interference (RFI). CAUTION should be exercised with regard to the use of portable communication equipment in the area around such equipment. If RFI causes erratic behavior, PUSH the Red Emergency Stop Button IMMEDIATELY. DO NOT turn the Red Emergency Stop Button OFF while transmission is in progress.

This product meets EN60601-1-2 Collateral Standard: Electromagnetic Compatibility.

MAINTENANCE

Maintenance MUST be performed ONLY by qualified personnel.

WARNING notices as used in this manual apply to hazards or unsafe practices which could result in serious bodily harm.

CAUTION notices as used in this manual apply to hazards or unsafe practices which could result in minor personal injury or property damage.

NOTES highlight procedures and contain information which assist the operator in understanding the information contained in this manual.

SAVE THESE INSTRUCTIONS AND KEEP WITH STAND UP LIFT AT ALL TIMES.

SYMBOL LEGEND



"ATTENTION, see instructions for use".

WARNING - ALWAYS be aware of the Lift Arms. Injury to the patient and/or assistant may occur.

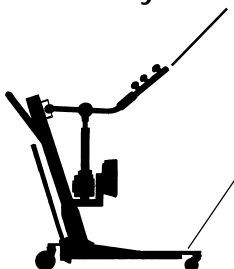

WARNING - ALWAYS be aware of the Footrest, especially the patient's position on the footrest. Injury to the patient and/or assistant may occur.



"Date of Manufacture"



Device contains NiCd batteries. DO NOT dispose of device or batteries in normal household waste. They MUST be taken to a proper disposal site. Contact your local waste management company for information.

TABLE OF CONTENTS

SPECIAL NOTES	2
SAFETY SUMMARY	4
SPECIFICATIONS	6
ASSEMBLY	6
OPERATION	7
OPERATING THE STAND UP LIFT	7
Closing/Opening the Legs of the Base	7
Locking/Unlocking the Rear Swivel Casters	7
Raising/Lowering Stand Up Lift	7
MOUNTING BATTERY CHARGER	8
CHARGING BATTERIES	8
TRANSFERRING FROM	10
LIFTING PREPARATION	10
LIFTING THE PATIENT	10
MOVING THE PATIENT	11
TRANSFERRING TO	12
TRANSFERRING THE PATIENT TO A WHEELCHAIR	12
TRANSFERRING THE PATIENT TO A BED	13
TRANSFERRING THE PATIENT TO A COMMUNE	14
MAINTENANCE SAFETY INSPECTION CHECKLIST	15
TROUBLESHOOTING	15
CARE AND MAINTENANCE OF YOUR STAND UP LIFT	16
LUBRICATION	16
WEAR AND DAMAGE	17
CLEANING	17
ADJUSTING THE BASE	17
ADJUSTING THE KNEE PAD HEIGHT	17
REPLACING THE KNEE PAD	18
REPLACING OPTIONAL LEG STRAP	18
REPLACING THE PADDED COVER	18
REPLACING ELECTRIC ACTUATOR	18
REPLACING CASTERS AND/OR FORKS	19
LIMITED WARRANTY	20

LÈVE-PATIENT - MODÈLE RPS350-121

LEVANTADOR - MODELO RPS350-140

TABLE OF CONTENTS

SAFETY SUMMARY

NOTE: Check all parts for shipping damage before using. In case of damage, DO NOT use the equipment. Contact the Carrier/Dealer for further instructions.

NOTE: The stand up lift may be operated by one (1) healthcare professional for ALL lifting preparation, transferring from and transferring to procedures with a cooperative, weight-bearing individual able to support the majority of his/her own weight. However, since medical conditions vary, Invacare recommends that the healthcare professional evaluate the need for assistance and determine whether more than one (1) assistant is appropriate in each case to safely perform the transfer.

WARNING

DO NOT attempt any transfer without approval of the patient's physician, nurse or medical assistant. Thoroughly read the instructions in this Owner's Manual, observe a trained team of experts perform the lifting procedures and then perform the entire lift procedure several times with proper supervision and a capable individual acting as a patient.

Individuals that use the Standing Sling (Model R130) **MUST** be able to support the majority of their own weight, otherwise injury can occur.

DO NOT raise the patient to a full standing position while using the transport sling (model R134), otherwise injury can occur.

Invacare standing and transport slings are specifically designed to be used in conjunction with the Invacare Stand Up Lift. Slings and accessories designed by other manufacturers or other Invacare slings are not to be utilized as a component of Invacare's stand up lift system. Use of these products is prohibited and will void Invacare's stand up lift warranty. Use only genuine Invacare standing and transport slings and lift accessories to maintain patient safety and product utility. Use the sling that is recommended by the individual's doctor, nurse or medical assistant for the comfort and safety of the individual being lifted.

Before positioning the legs of the stand up lift around the patient, make sure the patient's feet are out of the way of the footplate, otherwise injury can occur.

Invacare recommends locking the rear swivel casters **ONLY** when positioning or removing the sling (standing or transport) from around the patient.

Invacare does **NOT** recommend locking the rear swivel casters of the stand up lift when lifting and transferring an individual. Doing so could cause the lift to tip and endanger the patient and assistants. Invacare **DOES** recommend that the rear swivel casters be left **UNLOCKED** during lifting and transferring procedures to allow the stand up lift to stabilize itself when the patient is initially lifted from and transferred to a chair, bed or any stationary object.

STANDING SLINGS - **DO NOT** use the standing sling in combination with the stand up lift as a transport device. It is intended to transfer an individual from one resting surface to another (such as a bed to a wheelchair). Moving a person using the standing sling in combination with the stand up lift over **ANY** distance is **NOT** recommended.

STANDING SLINGS - Before lifting the patient, make sure the bottom edge of the standing sling is positioned on the lower back of the patient and the patient's arms are outside the standing sling.

STANDING SLINGS - The belt **MUST** be snug, but comfortable on the patient, otherwise the patient can slide out of the sling during transfer, possibly causing injury.

TRANSPORT SLINGS - Before lifting the patient, make sure the bottom edge of the transport sling is at the base of the spine and the patient's arms are outside the transport sling.

DO NOT use any kind of material (such as a plastic back incontinence pad or seating cushion) between the patient and sling material that may cause the patient to slide out of the sling during transferring.

ALWAYS use the color coded strap on the standing sling closest to the patient while still maintaining patient stability and comfort.

SAFETY SUMMARY, (continued)

WARNING

Bleached, torn, cut, frayed, or broken slings are unsafe and could result in injury. Discard immediately.

DO NOT alter slings.

When elevated a few inches off the surface being transferred from and before moving the patient, check again to make sure that the sling is properly connected to the attachment points of the stand up lift. If any attachments are NOT properly in place, lower the patient back onto the surface and correct this problem.

During transfer, with patient suspended in a sling attached to the lift, DO NOT roll stand up lift over objects such as carpet, raised carpet bindings, door frames, or any uneven surfaces or obstacles that would create an imbalance of the stand up lift and could cause the stand up lift to tip over. Use push handle on the mast at ALL times to push or pull the stand up lift.

Use push handle on the mast at ALL times to push or pull the stand up lift.

Casters and axle bolts require inspection every six (6) months to check for tightness and wear.

After the first 12 months of operation, inspect all pivot points and fasteners for wear. If the metal is worn, the parts MUST be replaced. Make this inspection every six (6) months thereafter.

The electric motor is sealed at the factory and if service is required, the motor unit MUST BE returned to the factory for repair. DO NOT attempt to open the motor or obtain local service as this will VOID the warranty and may result in damage and a costly repair. Consult your Dealer or Invacare for further information.

Regular maintenance of Stand Up Lift and accessories is necessary to assure proper operation.

Grounding Instructions:

DO NOT, under any circumstances, cut or remove the round grounding prong from any plug used with or for Invacare products. Some devices are equipped with three-prong (grounding) plugs for protection against possible shock hazards. Where a two-prong wall receptacle is encountered, it is the personal responsibility and obligation of the customer to contact a qualified electrician and have the two-prong receptacle replaced with a properly grounded three-prong wall receptacle in accordance with the National Electrical Code. If you must use an extension cord, use ONLY a three-wire extension cord having the same or higher electrical rating as the device being connected. In addition, Invacare has placed RED/ORANGE WARNING TAGS on some equipment. DO NOT remove these tags. Carefully read battery/battery charger information prior to operating, charging or servicing your stand up lift.

WEIGHT LIMITATION

DO NOT exceed maximum weight limitation of the Stand Up Lift. The maximum weight limitation is 350 lbs. regardless of any additional weight limitations on accessories.

SPECIFICATIONS

SPECIFICATIONS / ASSEMBLY

Stand Up Lift	
Height at Sling Hook-up Knob MAXIMUM:	66-inches
Height at Sling Hook-up Knob MINIMUM:	40-inches
Base Width OPEN:	37-inches
Base Width CLOSED:	26-inches
Base Height (Clearance):	4.5-inches
Base Length:	35.5-inches
Overall Height:	49-inches
Overall Length:	39-inches
Overall Width:	25.8-inches
Caster Size FRONT:	3-inches
Caster Size LOCKING REAR:	5-inches
Sling Options:	*Standing or Transport Polyester
Sling Material:	
Weight Capacity:	350lbs.
Weight:	108lbs.
Shipping Weight:	135lbs.
Battery:	24 VDC (RECHARGEABLE)
Charger Input:	100 - 240 VAC
Charger Output:	29.5 VDC
Charging Time:	Maximum 6 Hours
Audio Low Battery Alarm:	YES
Motor Safety Devices:	Anti-Entrapment
** Approx. Lifts per Charge:	**100-200 Cycles per Charge
Warranty (Electric/Electronics):	1 Year
Emergency Stop Button:	YES

*

PATIENT SLINGS:	STANDING	TRANSPORT
Width	36.0-inches	38.5-inches
Length	13.0-inches	36.0-inches

** Varies dependent upon load and stroke.

ASSEMBLY

ATTACHING MAST TO BASE (FIGURE 1)

1. Lock the rear swivel casters. Refer to **LOCKING/UNLOCKING THE REAR SWIVEL CASTERS** in this section of the manual.

2. Remove the hex bolt, nut and washer, that are located in the U-shape cut-out of the base.
3. Position the mast in an upright position and place the mast onto the U-shaped cut-out of the base.
4. Insert hex bolt with washers through the base and mast. Secure with nut.

WARNING

The mast may be removed from the base for storage or transporting. Each time mast is removed and returned to base, the mast **MUST** be properly secured to the base.

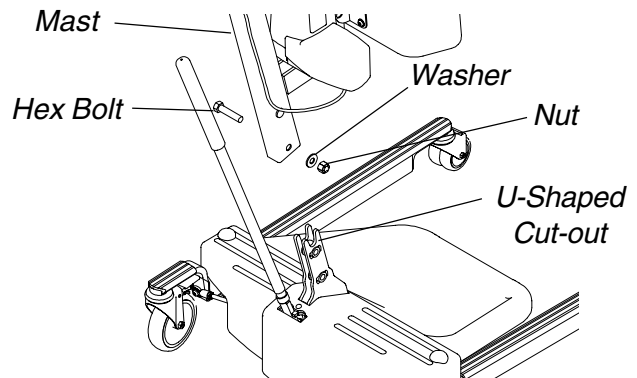

FIGURE 1 - ATTACHING MAST TO BASE

ATTACHING ELECTRIC ACTUATOR TO MAST (FIGURE 2)

1. Remove the top nut, top bolt, bracket and bushing from the lift arm mounting bracket.
2. Position the electric actuator in the lift arm mounting bracket as shown in **FIGURE 2**.
3. Reinstall top nut, top bolt, bracket and bushing into lift arm mounting bracket and electric actuator. Tighten securely.

CAUTION

DO NOT overtighten mounting hardware. This will damage mounting brackets.

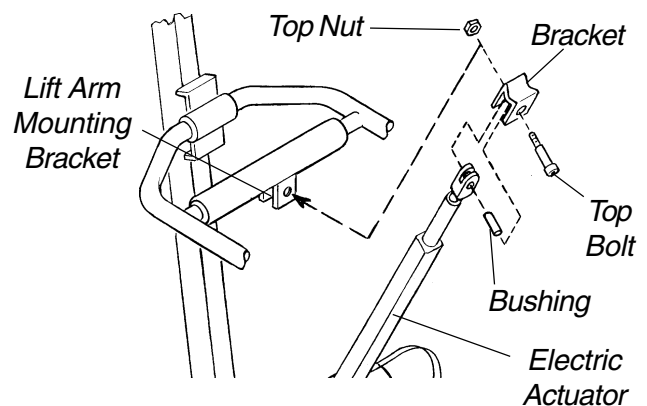

FIGURE 2 - ATTACHING ELECTRIC ACTUATOR TO MAST

OPERATION

OPERATING THE STAND UP LIFT

Closing/Opening the Legs of the Base (FIGURE 1)

The shifter handle is used to open or close the legs of the base for stability when lifting a patient.

- Stand at the rear of the stand up lift and grasp the shifter handle with one (1) hand and place the opposite hand on the push handle of the mast for balance.

NOTE: The shifter handle **MUST** lock into its mounting slot to lock the legs in the full open or closed position.

CLOSING.

- Pull the shifter handle OUT and away from the stand up lift and then to your LEFT until it LOCKS in the notch of the bracket.

NOTE: Left is determined by standing behind the stand up lift facing towards the front casters.

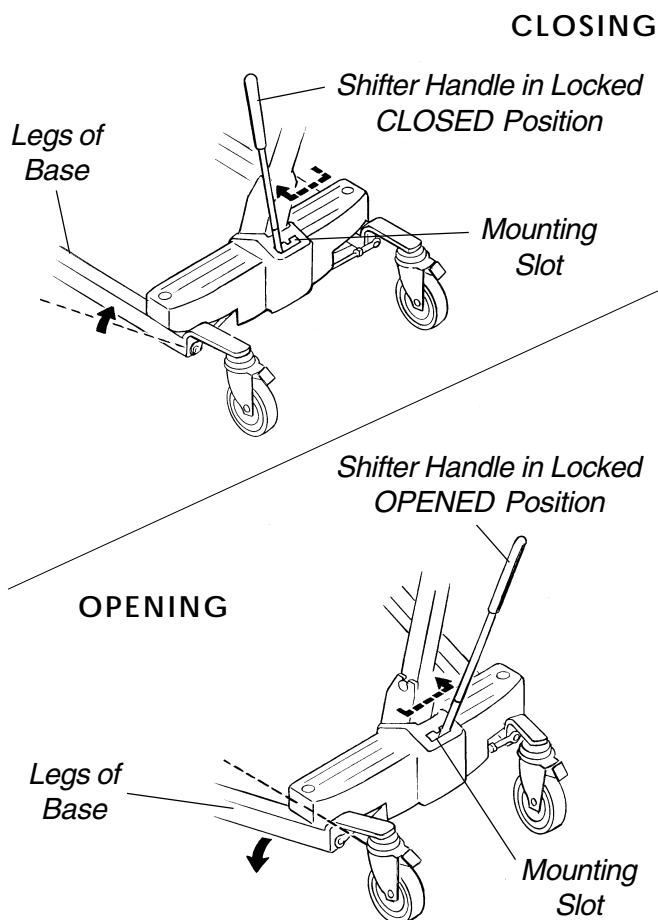

FIGURE 1- CLOSING/OPENING THE LEGS OF THE BASE

OPENING.

- Pull the shifter handle OUT and away from the stand up lift and then to your RIGHT until it LOCKS in the notch of the bracket.

NOTE: Right is determined by standing behind the stand up lift facing towards the front casters.

Locking/Unlocking the Rear Swivel Casters (FIGURE 2)

- Perform one (1) of the following:
 - LOCKING - Press DOWN on the BOTTOM of the locking lever.
 - UNLOCKING - Press DOWN on the TOP of the locking lever.

STEP HERE TO LOCK

STEP HERE TO UNLOCK

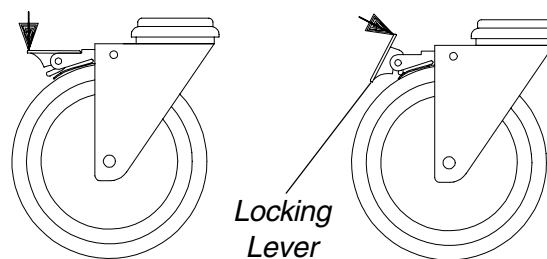

FIGURE 2 - LOCKING/UNLOCKING THE REAR SWIVEL CASTERS

Raising/Lowering Stand Up Lift (FIGURE 3)

RAISING THE LIFT. Press the UP (↑) button on the hand control to raise the lift arms and the patient.

LOWERING THE LIFT. Press the DOWN (↓) button on the hand control to lower the lift arms and the patient.

NOTE: If the Stand Up Lift is in the full UP position, it may be necessary to pull down slightly on the lift arms before the mast will lower.

EMERGENCY STOP. Press the RED button on the control box IN to stop the lift arms and patient from raising or lowering.

NOTE: Rotate RED emergency stop button CLOCKWISE until it pops out to disengage.

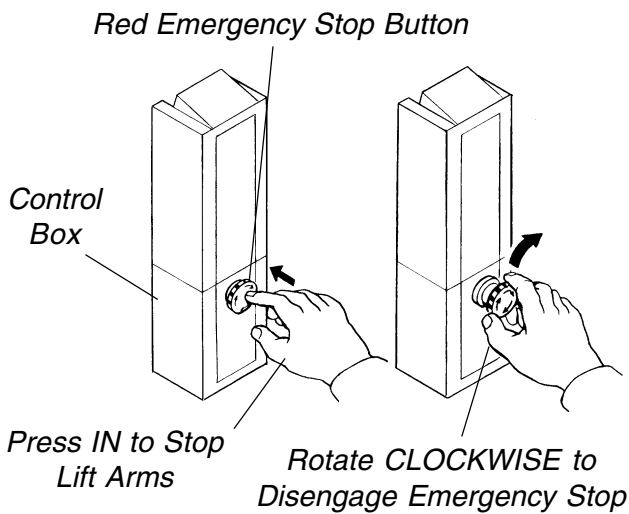
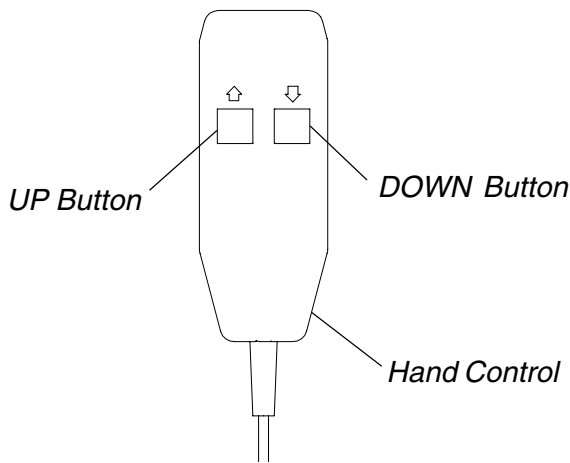

FIGURE 3 - RAISING/LOWERING STAND UP LIFT

MOUNTING BATTERY CHARGER (FIGURE 4)

NOTE: Refer to your local regulations concerning proper mounting procedures.

1. Place the battery charger with mounting bracket on the wall at the desired position.
2. With a pencil, mark the MIDDLE hole position.
3. Measure down 6-1/2-inches (16.5 cm) from the pencil mark and drill one (1) mounting hole.
4. Install the BOTTOM mounting screw until there is an approximate 1/8-inch (3 mm) gap between the screw head and the wall.
5. Install the battery charger with mounting bracket onto the bottom mounting screw.
6. Drill the remaining two (2) mounting holes.

7. Install the two (2) remaining mounting screws through the mounting bracket and into the wall. Tighten securely.
8. Plug the battery charger into the wall electrical outlet.

NOTE: ON LED should illuminate.

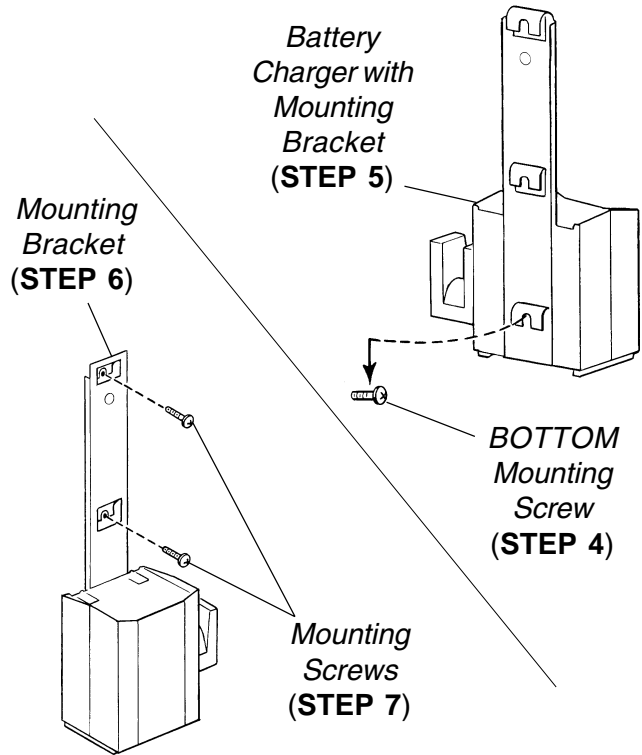

FIGURE 4 - MOUNTING BATTERY CHARGER

CHARGING BATTERIES (FIGURE 5)

NOTE: Invacare recommends the battery be recharged daily.

NOTE: An audible alarm will sound (horn will beep) when battery is low.

1. Lift UP on the handle on the top of the battery.
2. Lift the battery UP and OUT away from the control box.

WARNING

Make sure there is an audible click when mounting battery on the battery charger to confirm proper mounting. Otherwise, injury or damage may occur. Refer to FIGURE 5 for correct mounting.

3. Place the battery on the battery charger as shown in FIGURE 5. Make sure there is an audible click.

NOTE: The charge LED will illuminate. When charging is complete, the charge LED will stop illuminating.

NOTE: A battery needing to be fully recharged will take approximately four (4) hours.

4. Lift UP on the handle on the top of the battery.
5. Lift the battery UP and OUT away from the battery charger.

WARNING

Make sure there is an audible click when mounting battery on the control box to confirm proper mounting. Otherwise, injury or damage may occur. Refer to FIGURE 5 for correct mounting.

6. Reinstall the battery onto the control box as shown in FIGURE 5. Make sure there is an audible click.

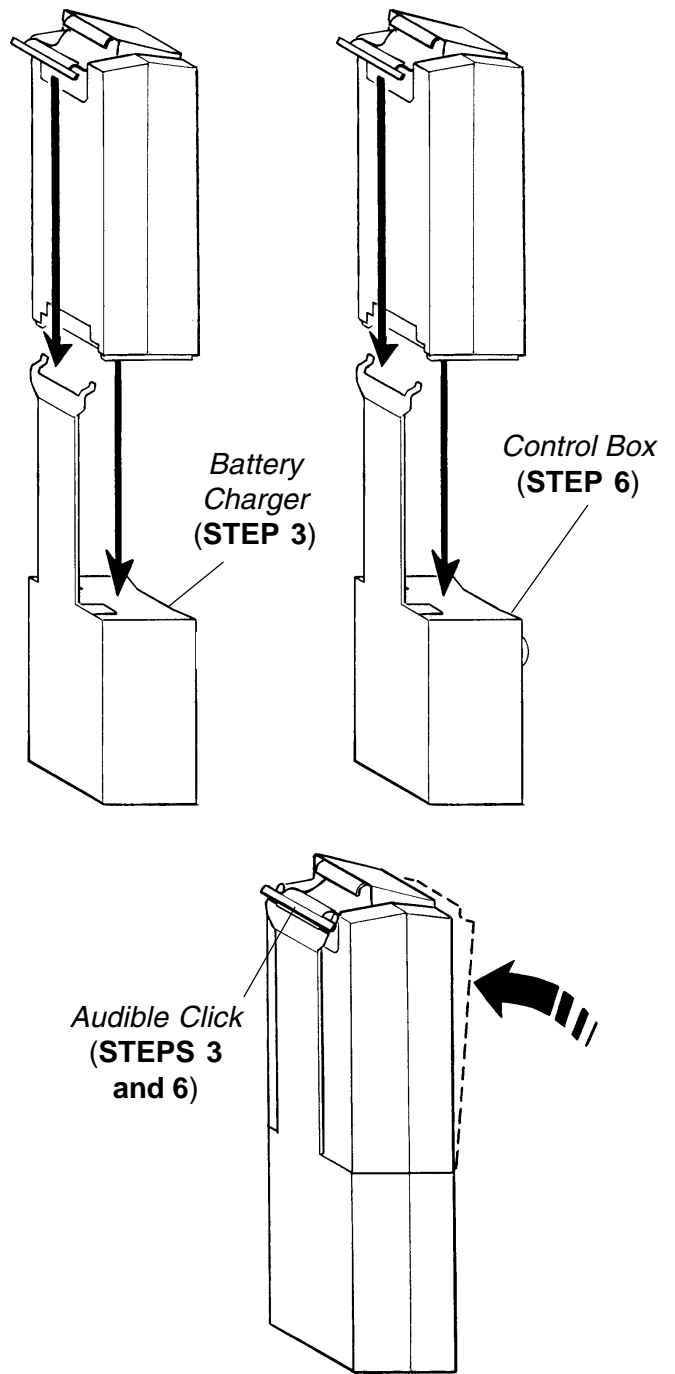
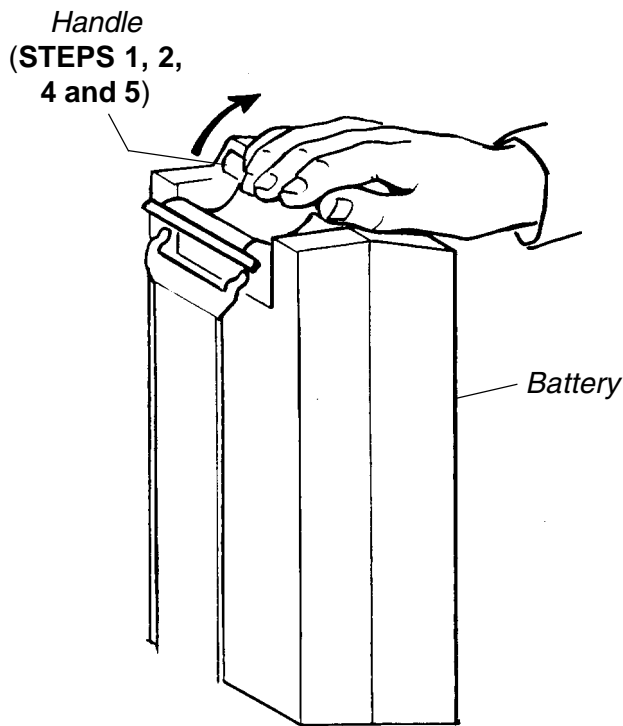

OPERATION

FIGURE 5 - CHARGING BATTERIES

TRANSFERRING FROM

TRANSFERRING FROM

LIFTING PREPARATION

Refer to the patient sling Owner's Manual, 1023891 for complete lifting preparation information.

NOTE: The stand up lift may be operated by one (1) healthcare professional for ALL lifting preparation, transferring from and transferring to procedures with a cooperative, weight-bearing individual able to support the majority of his/her own weight. However, since medical conditions vary, Invacare recommends that the healthcare professional evaluate the need for assistance and determine whether more than one (1) assistant is appropriate in each case to safely perform the transfer.

LIFTING THE PATIENT (FIGURE 1)

1. Instruct the patient to do the following:
 - A. Hold onto the hand grips on both sides of the stand up lift.
 - B. Lean back into the standing or transport sling.

WARNING

STANDING SLINGS - Before lifting the patient, make sure the bottom edge of the standing sling is positioned on the lower back of the patient and the patient's arms are outside the standing sling.

TRANSPORT SLINGS - Before lifting the patient, make sure the bottom edge of the transport sling is at the base of the spine and the patient's arms are outside the transport sling.

Invacare does NOT recommend locking the rear casters of the stand up lift when lifting and transferring an individual. Doing so could cause the lift to tip and endanger the patient and assistants. Invacare DOES recommend that the rear casters be left UNLOCKED during lifting and transferring procedures to allow the stand up lift to stabilize itself when the patient is initially lifted from and transferred to a chair, bed or any stationary object.

2. Make sure of the following:
 - A. Patient's knees are secure against the knee pad.
 - B. Patient's feet are positioned on the footplate as shown in **STEP 2B** of **FIGURE 1**.
 - C. The bottom edge of the:
 - Standing Sling** is positioned on the lower back.
 - Transport Sling** is at the base of the patient's spine.
 - D. The patient's arms are outside of the standing or transport sling.

- E. The rear casters are unlocked.
- F. Make sure the legs are in the maximum open position and the shifter handle is locked in place.

WARNING

When elevated a few inches off the surface being transferred from and before moving the patient, check again to make sure that the sling is properly connected to the attachment points of the stand up lift. If any attachments are NOT properly in place, lower the patient back onto the surface and correct this problem.

Adjustments for safety and comfort should be made before moving the patient.

Invacare standing and transport slings are specifically designed to be used in conjunction with the Invacare Stand Up Lift. Slings and accessories designed by other manufacturers or other Invacare slings are not to be utilized as a component of Invacare's stand up lift system. Use of these products is prohibited and will void Invacare's stand up lift warranty. Use only genuine Invacare standing and transport slings and lift accessories to maintain patient safety and product utility.

If transferring from a wheelchair: Wheelchair wheel locks **MUST** be in the locked position **BEFORE** lowering the patient into the wheelchair.

3. Transferring from a wheelchair - Lock the wheel locks of the wheelchair.
4. Press the UP (↑) button to raise the patient above the surface (bed, wheelchair or commode) being transferred from. The patient should be elevated just high enough to clear the surface with their weight fully supported by the lift.

NOTE: The lower center of gravity provides stability making the patient feel more secure and the lift easier to move.

NOTE: The lift arms will stay in position until the DOWN (↓) button is pressed.

5. Move the patient to the desired surface. Refer to **MOVING THE PATIENT** in this section of the manual.

STEP 1A

STEP 1B

MOVING THE PATIENT (FIGURE 2)

WARNING

STANDING SLINGS - DO NOT use the standing sling in combination with the stand up lift as a transport device. It is intended to transfer an individual from one resting surface to another (such as a bed to a wheelchair). Moving a person using the standing sling in combination with the stand up lift over ANY distance is NOT recommended.

During transfer, with patient suspended in a sling attached to the lift, **DO NOT** roll stand up lift over objects such as carpet, raised carpet bindings, door frames, or any uneven surfaces or obstacles that would create an imbalance of the stand up lift and could cause the stand up lift to tip over. Use push handle on the mast at ALL times to push or pull the stand up lift.

1. Using the push handle, move the stand up lift away from the surface.
2. SLOWLY, move the patient to the desired surface.
3. Lower the patient onto the desired surface. Refer to **TRANSFERRING TO** in this manual.

STEP
2E

STEP
2A

STEP
2B
STEP 3

STEP
2D

STEP
2C

STEP 1

STEP 4

FIGURE 2 - MOVING THE PATIENT

FIGURE 1 - LIFTING THE PATIENT

TRANSFERRING TO

TRANSFERRING TO

NOTE: The stand up lift may be operated by one (1) healthcare professional for ALL lifting preparation, transferring from and transferring to procedures with a cooperative, weight-bearing individual able to support the majority of his/her own weight. However, since medical conditions vary, Invacare recommends that the healthcare professional evaluate the need for assistance and determine whether more than one (1) assistant is appropriate in each case to safely perform the transfer.

STEP 1

TRANSFERRING THE PATIENT TO A WHEELCHAIR (FIGURE 1)

1. Move the wheelchair into position.

WARNING

Wheelchair wheel locks **MUST** be in the locked position **BEFORE** lowering the patient into the wheelchair.

STEP 2

2. Lock the rear wheels of the wheelchair.
3. Position the patient over the wheelchair.
4. Press the DOWN (↓) button and lower the patient into the wheelchair.

WARNING

Invacare recommends locking the rear swivel casters **ONLY** when positioning or removing the sling (standing or transport) from around the patient.

5. Lock the rear swivel casters. Refer to **LOCKING/UNLOCKING THE REAR SWIVEL CASTERS** in the **OPERATION** section of this manual.
6. Unhook the standing or transport sling from all attachment points on the stand up lift.
7. If equipped, unfasten the leg strap from around the patient's legs.
8. Instruct the patient to lift their feet off of the footplate.

STEP 4

NOTE: Assist the patient if necessary.

9. Remove the standing or transport sling from around the patient.
10. Pull the stand up lift away from the wheelchair.

STEP 6

FIGURE 1 - TRANSFERRING THE PATIENT TO A WHEELCHAIR

TRANSFERRING THE PATIENT TO A BED (FIGURE 2)

STEPS 1 AND 2

NOTE: The lower center of gravity provides stability making the patient feel more secure and the lift easier to move.

NOTE: The lift arms will stay in position until the DOWN (↓) button is pressed.

1. Position the patient as far over the bed as possible.

NOTE: If patient is being transferred from a surface that is lower than the bed, press the UP (↑) button to raise the patient above the surface of the bed. The patient should be elevated just high enough to clear the bed with their weight fully supported by the lift.

2. Press the DOWN (↓) button and lower the patient onto the bed.

WARNING

Invacare recommends locking the rear swivel casters **ONLY** when positioning or removing the sling (standing or transport) from around the patient.

STEP 4

3. Lock the rear swivel casters. Refer to **LOCKING/ UNLOCKING THE REAR SWIVEL CASTERS** in the **OPERATION** section of this manual.
4. Unhook the standing or transport sling from all attachment points on the stand up lift.
5. If equipped, unfasten the leg strap from around the patient's legs.
6. Instruct the patient to lift their feet off of the footplate.

NOTE: Assist the patient if necessary.

7. Remove the standing or transport sling from around the patient.
8. Pull the stand up lift away from the bed.

FIGURE 2 - TRANSFERRING THE PATIENT TO A BED

TRANSFERRING THE PATIENT TO A COMMUNE (FIGURE 3)

STEP 1

1. Position the patient over the commode.
2. Press the DOWN (↓) button and lower the patient onto the commode.

WARNING

Invacare recommends locking the rear swivel casters **ONLY** when positioning or removing the sling (standing or transport) from around the patient.

3. Lock the rear swivel casters. Refer to **LOCKING/ UNLOCKING THE REAR SWIVEL CASTERS** in the **OPERATION** section of this manual.
4. Perform one (1) of the following:
 - A. Standing Sling (Model R130) -
 - Unhook the standing sling from the attachment points on the stand up lift.
 - B. Transport Slings (Model R134) -
 - Unhook the transport sling from the bottom attachment points on the stand up lift.
 - Lift up on the patient's legs and remove the thigh supports from underneath the patient.
 - If desired, unhook the transport sling from the top attachment points on the stand up lift.

STEP 3

NOTE: The patient can remain in the upper portion of the transport sling while using the commode.

5. If equipped, unfasten the leg strap from around the patient's legs.
6. Instruct the patient to lift their feet off of the footplate.

NOTE: Assist the patient if necessary.

7. Remove the standing or transport sling from around the patient.
8. Pull the stand up lift away from the commode.
9. Once the patient is ready to be transferred, refer to the **LIFTING PREPARATION** section of this manual.

STEPS 4 AND 5

T
R
A
N
S
F
E
R
R
I
N
G
T
O

FIGURE 3 - TRANSFERRING THE PATIENT TO A COMMUNE

MAINTENANCE SAFETY INSPECTION CHECKLIST

ITEM	INITIALLY	INSTITUTIONAL INSPECT/ADJUST MONTHLY	IN-HOME INSPECT EVERY SIX (6) MONTHS *
THE CASTER BASE			
● Inspect for missing hardware.	X	X	X
● Base opens/closes with ease.	X	X	X
● Inspect casters and axle bolts for tightness and wear.	X	X	X
● Inspect casters for smooth swivel and roll.	X	X	X
SHIFTER HANDLE			
● Operates smoothly.	X	X	X
● Locks adjustable base whenever engaged.	X	X	X
THE MAST			
● Mast MUST be securely assembled to lift arms.	X	X	X
● Inspect for bends or deflections.	X	X	X
THE LIFT ARMS AND LINKAGE			
● Check all hardware and attachment points.	X	X	X
● Inspect for bends or deflections.	X	X	X
● Inspect bolted joints of lift arms for wear.	X	X	X
● Inspect to ensure that the lift arms are centered between the base legs.	X	X	X
THE ELECTRIC ACTUATOR ASSEMBLY			
● Check for wear or deterioration (IF DAMAGED, CONTACT DEALER).	X	X	X
● Cycle to ensure smooth quiet operation.	X	X	X
CLEANING **			
● Whenever necessary.	X	X	X
SLINGS			
● CHECK ALL SLING ATTACHMENTS each time it is used to ensure proper connection and patient safety.	X	X	X
● Inspect sling material for wear.	X	X	X
● Inspect straps for wear.	X	X	X

* NOTE: For individual home use, a full inspection is required prior to each new user.

** NOTE: Regular cleaning will reveal loose or worn parts, enhance smooth operation and extend the life expectancy of the lift.

TROUBLESHOOTING

SYMPTOMS	FAULTS	SOLUTION
Stand up lift feels loose.	Mast/Base joint loose. Tie - Rods are loose.	Tighten the bolt, washer and locknut that secure the mast to the base. Refer to BASE ADJUSTMENT in the CARE AND MAINTENANCE section of this manual.
Casters/Brakes noisy or stiff.	Fluff or debris in bearings.	Refer to CASTERS in the CARE AND MAINTENANCE section of this manual.

TROUBLESHOOTING (CONT.)

T R O U B L E S H O O T I N G

SYMPTOMS	FAULTS	SOLUTION
Noisy or dry sound from pivots.	Needs lubrication.	Refer to LUBRICATION in the CARE AND MAINTENANCE section of this manual.
Electric actuator fails to lift when button is pressed.	Hand-control or actuator connector loose. RED emergency stop button pressed IN. Batteries low. Battery not connected properly to control box. The connecting terminals are damaged. Electric actuator in need of service or load is too high.	Check connections. Rotate RED emergency stop button CLOCKWISE until it pops out. Charge batteries. Refer to CHARGING BATTERIES in the OPERATION section of this manual. Reconnect the battery to the control box. Refer to CHARGING BATTERIES in the OPERATION section of this manual. Replace the battery pack. Refer to CHARGING BATTERIES in the OPERATION section of this manual. Refer to ELECTRIC ACTUATOR REPLACEMENT in the CARE AND MAINTENANCE section of this manual. Contact your Dealer.
Unusual noise from actuator.	Actuator is worn or damaged or spindle is bent.	Refer to ELECTRIC ACTUATOR REPLACEMENT in the CARE AND MAINTENANCE section of this manual. Contact your Dealer.
Lift arms will not lower in uppermost position.	Lift arms require a minimum weight load to lower from the uppermost position.	Pull down slightly on the lift arms.

C A R E - M A I N T E N A N C E

NOTE: If problems are not remedied by the suggested means, please contact your Dealer or Invacare.

CARE AND MAINTENANCE OF YOUR STAND UP LIFT

NOTE: Follow the maintenance procedures described in this manual to keep your stand up lift in continuous service.

The Invacare Stand Up Lift is designed to provide a maximum of safe, efficient and satisfactory service with minimum care and maintenance.

All parts of the Invacare Stand Up Lift are made of the best grades of steel, but metal to metal contact will wear after considerable use.

There is no adjustment or maintenance of either the casters or brakes, other than cleaning, lubrication and checking axle and swivel bolts for tightness. Remove all debris, etc. from the wheel and swivel bearings. If any parts are worn, replace these parts immediately.

If you question the safety of any part of the lift, contact your Dealer immediately and advise him/her of your problem.

LUBRICATION (FIGURE 1)

The Invacare Stand Up Lift is designed for minimum maintenance; however, a six (6) month check should ensure continued safety and reliability.

Keep lift and slings clean and in good working order. Any defect should be noted and reported to your dealer as soon as possible.

The casters MUST swivel and roll smoothly. A light grease (waterproof auto lubricant) may be applied to the ball bearing swivel of the casters once a year. Apply more frequently if the casters are exposed to extreme moist conditions.



Lubricate the Bearings in the Caster Swivels

FIGURE 1 - LUBRICATION

WEAR AND DAMAGE

It is important to inspect all stressed parts, such as slings and any attachment point for slings for signs of cracking, fraying, deformation or deterioration. Replace any defective parts immediately and ensure that the lift is not used until repairs are made.

CLEANING

The sling should be washed regularly in water temperature of 140°F (60°C) and a biological solution. A soft cloth, dampened with water and a small amount of mild detergent, is all that is needed to clean the stand up lift. The lift can be cleaned with non-abrasive cleaners.

ADJUSTING THE BASE (FIGURE 2)

NOTE: The base adjustment should not require any attention other than:

1. Check the squareness of the legs when in the CLOSED position.
2. Place a square on the inside of the legs and base to determine the 90° alignment.
3. Adjust the linkage rods until 90° alignment is achieved.

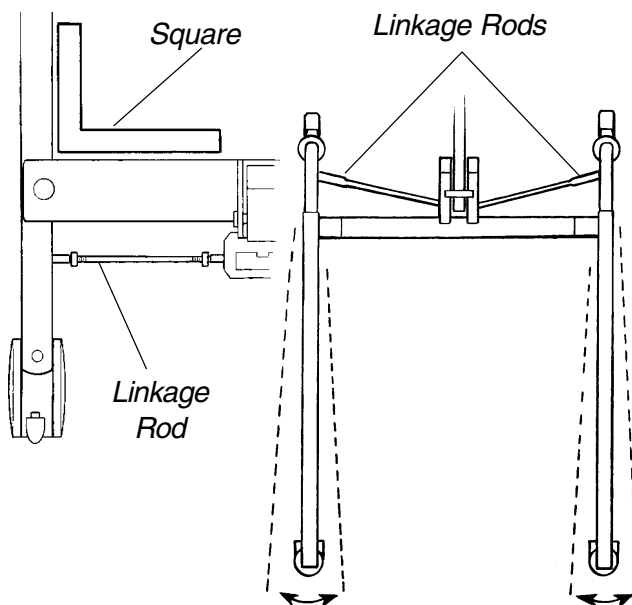

FIGURE 2 - ADJUSTING THE BASE

ADJUSTING THE KNEE PAD HEIGHT (FIGURE 3)

NEVER adjust knee pad while patient is in the standing position.

NEVER try to adjust knee pad while the lift is moving.

ALWAYS make sure that the adjustment pins are engaged in corresponding height adjustment holes before using.

1. Pick a height setting that will be comfortable to the patient and provide the necessary support.

NOTE: The knee pad should be positioned so that the knee portion of the leg is in contact with the pad.

2. Using both hands, pull both adjustment pins outward at the same time.
3. Position the knee pad to the desired height and release adjustment pins into the corresponding alignment holes.
4. Check to make sure that both pins are engaged.

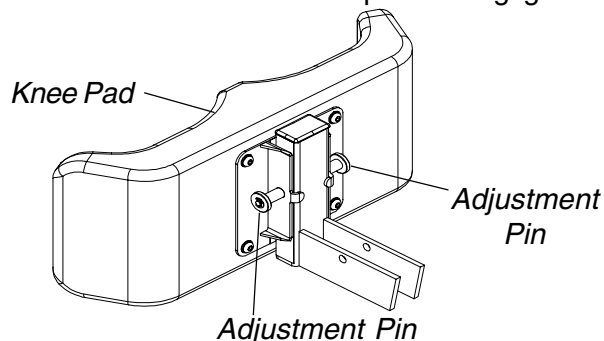

FIGURE 3 - ADJUSTING THE KNEE PAD HEIGHT

REPLACING THE KNEE PAD (FIGURE 4)

1. Remove the four (4) button screws and washers that secure existing knee pad to the stand up lift.
2. Remove the existing knee pad from stand up lift.
3. Position the mounting holes in the new knee pad with the mounting holes in the stand up lift.
4. Using the existing hardware, secure the new knee pad to the stand up lift.

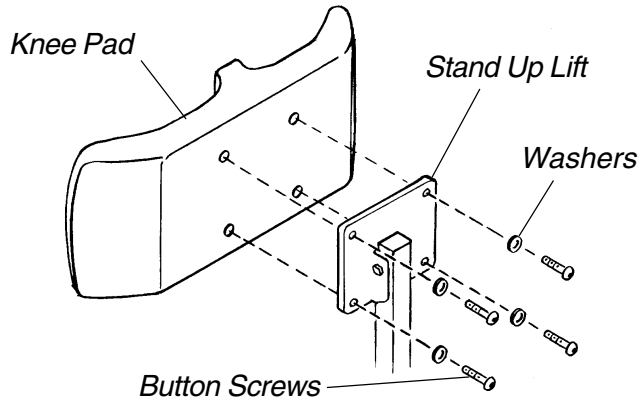

FIGURE 4 - REPLACING THE KNEE PAD

REPLACING OPTIONAL LEG STRAP (FIGURE 5)

1. Remove TOP (2) button screws and washers that secure knee pad and existing leg strap to stand up lift.
2. Loosen BOTTOM two (2) button screws and washers that secure knee pad and existing leg strap to stand up lift.
3. Remove the existing leg strap from stand up lift.
4. Position the new leg strap between the four (4) mounting holes as shown in **FIGURE 5**.

NOTE: Make sure there is equal amounts of leg strap on either side of the stand up lift.

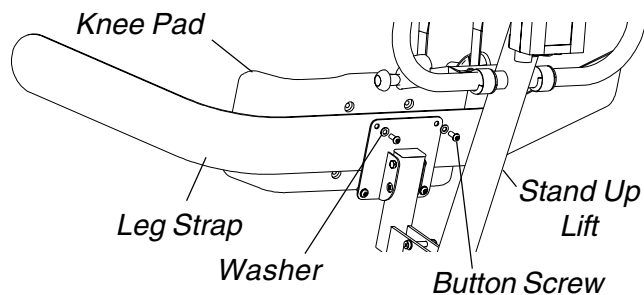

FIGURE 5 - REPLACING OPTIONAL LEG STRAP

5. Position the mounting holes in the knee pad with the mounting holes in the stand up lift.
6. Using the existing hardware, secure the knee pad and new leg strap to the stand up lift.

REPLACING THE PADDED COVER (FIGURE 6)

1. Pull fastening strips on the existing padded cover apart.
2. Remove the existing padded cover from the lift arm.
3. Position the new padded cover around the lift arm.
4. Secure fastening strips on the new padded cover together.

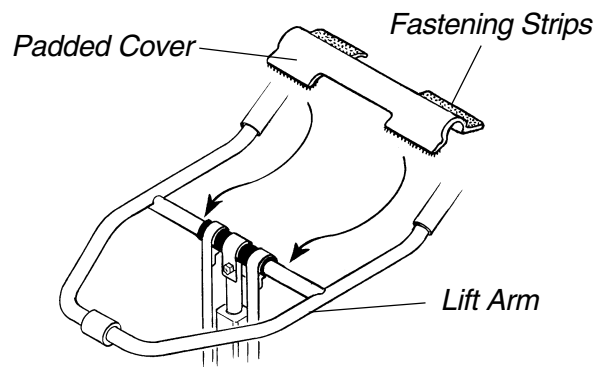

FIGURE 6 - REPLACING THE PADDED COVER

REPLACING ELECTRIC ACTUATOR (FIGURE 7)

1. Remove the bottom nut, washer and shoulder bolt that secure the electric actuator to the mast mounting bracket.
2. Rest the lift arm on your shoulder and remove the top nut, bolt, bracket and bushing from the lift atm mounting bracket.
3. Remove the electric actuator.
4. Reverse **STEPS 1-3** for installation of the new electric actuator.

CAUTION
DO NOT overtighten mounting hardware. This will damage mounting brackets.

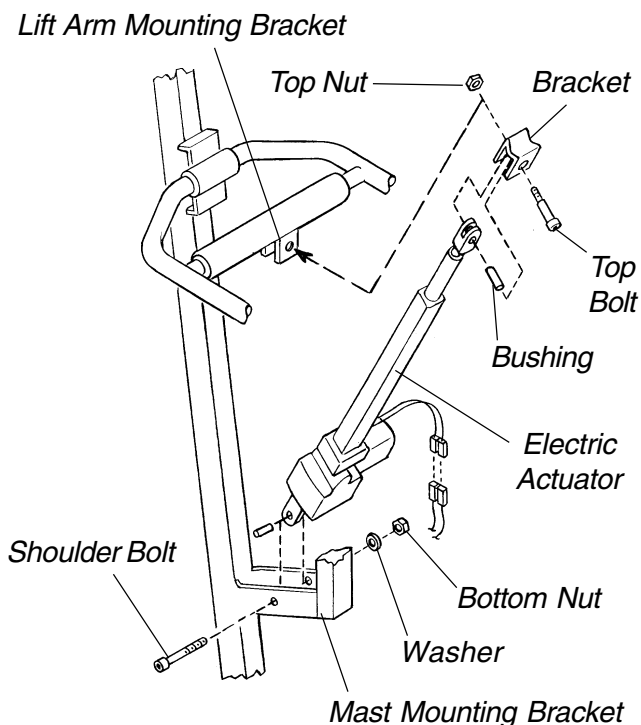

FIGURE 7 - REPLACING ELECTRIC ACTUATOR

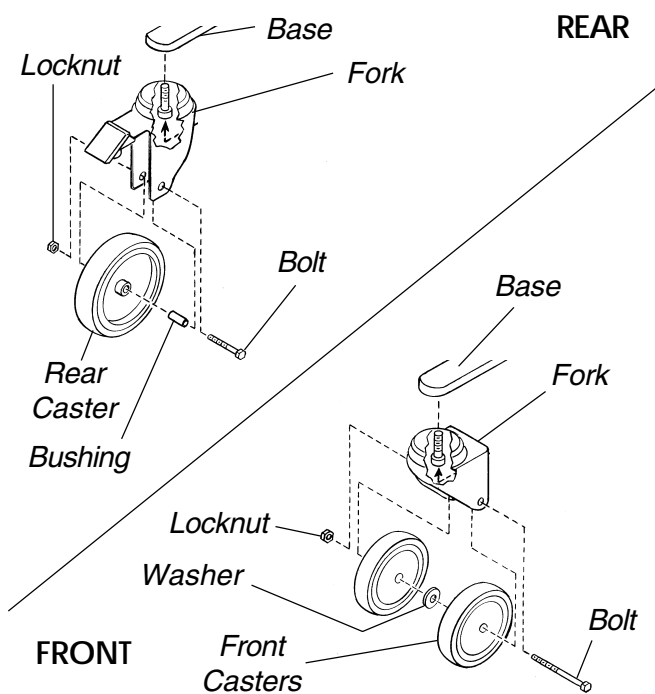

FIGURE 8 - REPLACING CASTERS AND/OR FORKS

REPLACING CASTERS AND/OR FORKS (FIGURE 8)

WARNING

Casters and axle bolts require inspection every six (6) months to check for tightness and wear.

Rear Casters

1. Place the stand up lift on its side.
2. Remove the bolt and locknut that secure the existing rear caster to the fork.

NOTE: The bushing will fall out of the rear caster.

NOTE: Existing bushing will be reused. Examine and replace if worn.

3. Install new/existing bushing into the new rear caster.
4. Line up the mounting holes in the new rear caster and the fork.
5. Install the bolt through the fork and new rear caster and tighten securely with the locknut.

Front Casters

1. Place the stand up lift on its side.
2. Remove the bolt and locknut that secure the existing front caster assembly to the fork.

NOTE: The front caster assembly consists of two (2) casters and a washer in between.

NOTE: The washer will fall out from between the two (2) casters.

NOTE: Existing washer will be reused. Examine and replace if worn.

3. Position new/existing washer between the two (2) new casters.
4. Line up the mounting holes in the new front caster assembly and the fork.
5. Install the bolt through the fork and new front caster assembly and tighten securely with the locknut.

Forks

1. Place the stand up lift on its side.
2. Remove the front or rear caster from the stand up lift. Refer to **REPLACING CASTERS** in this section of the manual.
3. Unscrew the existing fork from the base.
4. Install the new fork onto the base.
5. Install the front or rear caster onto the stand up lift. Refer to **REPLACING CASTERS** in this section of the manual.

LIMITED WARRANTY

LIMITED WARRANTY

PLEASE NOTE: THE WARRANTY BELOW HAS BEEN DRAFTED TO COMPLY WITH FEDERAL LAW APPLICABLE TO PRODUCTS MANUFACTURED AFTER JULY 4, 1975.

This warranty is extended only to the original purchaser/user of our products.

This warranty gives you specific legal rights and you may also have other legal rights which vary from state to state.

Invacare warrants the products manufactured to be free from defects in materials and workmanship for a period of three (3) years on the lift and one (1) year on the slings and electric components from the date of purchase. If within such warranty period any such product shall be proven to be defective, such product shall be repaired or replaced, at Invacare's option. This warranty does not include any labor or shipping charges incurred in replacement part installation or repair of any such product. Invacare's sole obligation and your exclusive remedy under this warranty shall be limited to such repair and/or replacement.

For warranty service, please contact the dealer from whom you purchased your Invacare product. In the event you do not receive satisfactory warranty service, please write directly to Invacare at the address on the back cover, provide dealer's name, address, and the date of purchase, indicate nature of the defect.

Invacare Corporation will issue a serialized return authorization. The defective unit or parts MUST be returned for warranty inspection using the serial number, when applicable as identification within 30 days of return authorization date. Do not return products to our factory without our prior consent. C.O.D. shipments will be refused; please prepay shipping charges.

LIMITATIONS AND EXCLUSIONS: THE FOREGOING WARRANTY SHALL NOT APPLY TO SERIAL NUMBERED PRODUCTS IF THE SERIAL NUMBER HAS BEEN REMOVED OR DEFACED, PRODUCTS SUBJECTED TO NEGLIGENCE, ACCIDENT, IMPROPER OPERATION, MAINTENANCE OR STORAGE, PRODUCTS MODIFIED WITHOUT INVACARE'S EXPRESS WRITTEN CONSENT (INCLUDING, BUT NOT LIMITED TO, MODIFICATION THROUGH THE USE OF UNAUTHORIZED PARTS OR ATTACHMENTS; PRODUCTS DAMAGED BY REASON OF REPAIRS MADE TO ANY COMPONENT WITHOUT THE SPECIFIC CONSENT OF INVACARE, OR TO A PRODUCT DAMAGED BY CIRCUMSTANCES BEYOND INVACARE'S CONTROL, AND SUCH EVALUATION WILL BE SOLELY DETERMINED BY INVACARE. THE WARRANTY SHALL NOT APPLY TO PROBLEMS ARISING FROM NORMAL WEAR OR FAILURE TO ADHERE TO THE INSTRUCTIONS IN THIS MANUAL.

THE FOREGOING WARRANTY IS EXCLUSIVE AND IN LIEU OF ALL OTHER EXPRESS WARRANTIES. IMPLIED WARRANTIES, IF ANY, INCLUDING THE IMPLIED WARRANTIES OF MERCHANTABILITY AND FITNESS FOR A PARTICULAR PURPOSE, SHALL NOT EXTEND BEYOND THE DURATION OF THE EXPRESSED WARRANTY PROVIDED HEREIN AND THE REMEDY FOR VIOLATIONS OF ANY IMPLIED WARRANTY SHALL BE LIMITED TO REPAIR OR REPLACEMENT OF THE DEFECTIVE PRODUCT PURSUANT TO THE TERMS CONTAINED HEREIN. INVACARE SHALL NOT BE LIABLE FOR ANY CONSEQUENTIAL OR INCIDENTAL DAMAGES WHATSOEVER.

SOME STATES DO NOT ALLOW EXCLUSION OR LIMITATION OF INCIDENTAL OR CONSEQUENTIAL DAMAGE, OR LIMITATION ON HOW LONG AN IMPLIED WARRANTY LASTS, SO THE ABOVE EXCLUSIONS AND LIMITATIONS MAY NOT APPLY TO YOU.

THIS WARRANTY SHALL BE EXTENDED TO COMPLY WITH STATE OR PROVINCIAL LAWS AND REQUIREMENTS.



Yes, you can.™

Invacare Corporation

www.invacare.com

USA

One Invacare Way
Elyria, Ohio USA
44036-2125
800-333-6900

Canada

5970 Chedworth Way
Mississauga, Ontario
L5R 3T9, Canada
905-890-8838

Yes, You Can and Invacare are registered trademarks of
Invacare Corporation.

© 2000 Invacare Corporation

Form No. 98-137 Part No. 1078984 Rev D (2) 6/00